

# City of San Diego

Portillo Concrete, Inc.

CONTRACTOR'S NAME: \_\_\_\_\_  
ADDRESS: 3527 Citrus St., Lemon Grove, CA 91945  
TELEPHONE NO.: 619-466-4639 FAX NO.: 619-466-4685  
CITY CONTACT: Rosa Riego, Contract Specialist, Email: RRiego@sandiego.gov  
Phone No. (619) 533-3426, Fax No. (619) 533-3633  
D. Promarl / A. Jaro / LJI

## BIDDING DOCUMENTS



FOR

ORIGINAL

## Sidewalk Replacement Group 1601

BID NO.: \_\_\_\_\_ K-17-1508-DBB-3  
SAP NO. (WBS/IO/CC): \_\_\_\_\_ B-16027  
CLIENT DEPARTMENT: \_\_\_\_\_ 2116  
COUNCIL DISTRICT: \_\_\_\_\_ 4, 8, 9  
PROJECT TYPE: \_\_\_\_\_ IK

### THIS CONTRACT WILL BE SUBJECT TO THE FOLLOWING:

- > THE CITY'S SUBCONTRACTING PARTICIPATION REQUIREMENTS FOR SLBE PROGRAM.
- > BID DISCOUNT PROGRAM (The WHITEBOOK, SLBE-ELBE Program Requirements, Section IV(2))
- > PREVAILING WAGE RATES: STATE  FEDERAL
- > APPRENTICESHIP

### BID DUE DATE:

2:00 PM

JANUARY 4, 2017

CITY OF SAN DIEGO

PUBLIC WORKS CONTRACTS

1010 SECOND AVENUE, 14<sup>th</sup> FLOOR, MS 614C

SAN DIEGO, CA 92101

**ENGINEER OF WORK**

The engineering Specifications and Special Provisions contained herein have been prepared by or under the direction of the following Registered Engineer:

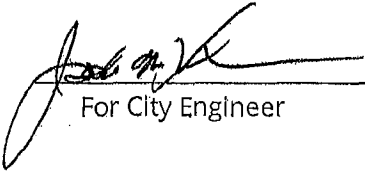
  
\_\_\_\_\_  
For City Engineer

11/16/2016

Date

Seal



**TABLE OF CONTENTS**

<b>SECTION .....</b>	<b>PAGE</b>
1. NOTICE INVITING BIDS.....	4
2. INSTRUCTIONS TO BIDDERS .....	7
3. PERFORMANCE BOND, LABOR AND MATERIALMEN'S BONDS.....	17
4. ATTACHMENTS:	
A. SCOPE OF WORK.....	20
B. INTENTIONALLY LEFT BLANK.....	22
C. INTENTIONALLY LEFT BLANK.....	23
D. PREVAILING WAGES.....	24
E. SUPPLEMENTARY SPECIAL PROVISIONS .....	28
1. Appendix A - Notice of Exemption.....	38
2. Appendix B - Fire Hydrant Meter Program.....	50
3. Appendix C - Materials Typically Accepted by Certificate of Compliance .....	64
4. Appendix D - Sample City Invoice.....	66
5. Appendix E - Location Maps.....	68
6. Appendix F - Locations List.....	182
7. Appendix G - Tree Related Drawing Details .....	196
8. Appendix H - Hazardous Label/Forms.....	202
9. Appendix I - Sample of Public Notices.....	208
10. Appendix J - Advanced Metering Infrastructure (AMI) Device Protection .....	210
F. INTENTIONALLY LEFT BLANK.....	217
G. CONTRACT AGREEMENT .....	218
5. CERTIFICATIONS AND FORMS.....	221

## NOTICE INVITING BIDS

1. **SUMMARY OF WORK:** This is the City of San Diego's (City) solicitation process to acquire Construction services for **Sidewalk Replacement Group 1601**. For additional information refer to Attachment A.
2. **FULL AND OPEN COMPETITION:** This contract is open to full competition and may be bid on by Contractors who are on the City's current Prequalified Contractors' List. For information regarding the Contractors Prequalified list visit the City's web site: <http://www.sandiego.gov>.
3. **ESTIMATED CONSTRUCTION COST:** The City's estimated construction cost for this project is **\$901,000**.
4. **BID DUE DATE AND TIME ARE:** January 4, 2017 at 2:00 P.M.
5. **PREVAILING WAGE RATES APPLY TO THIS CONTRACT:** Refer to Attachment D.
6. **LICENSE REQUIREMENT:** The City has determined that the following licensing classifications are required for this contract: **A or C8 or C-12**.
7. **SUBCONTRACTING PARTICIPATION PERCENTAGES:** Subcontracting participation percentages apply to this contract.
  - 7.1. The City has incorporated **mandatory** SLBE-ELBE subcontractor participation percentages to enhance competition and maximize subcontracting opportunities. For the purpose of achieving the mandatory subcontractor participation percentages, a recommended breakdown of the SLBE and ELBE subcontractor participation percentages based upon certified SLBE and ELBE firms has also been provided to achieve the mandatory subcontractor participation percentages:

1. SLBE participation	<b>6.3%</b>
2. ELBE participation	<b>8.1%</b>
3. Total mandatory participation	<b>14.4%</b>
  - 7.2. The Bid may be declared non-responsive if the Bidder fails to meet the following requirements:
    - 7.2.1. Include SLBE-ELBE certified subcontractors at the overall mandatory participation percentage identified in this document; **OR**
    - 7.2.2. Submit Good Faith Effort documentation, saved in searchable Portable Document Format (PDF) and stored on Compact Disc (CD) or Digital Video Disc (DVD), demonstrating the Bidder made a good faith effort to outreach to and include SLBE-ELBE Subcontractors required in this document within 3 Working Days of the Bid opening if the overall mandatory participation percentage is not met.



**8. PRE-BID MEETING:**

- 8.1. Prospective Bidders are encouraged to attend the Pre-Bid Meeting. The purpose of the meeting is to discuss the scope of the Project, submittal requirements, the pre-qualification process and any Equal Opportunity Contracting Program requirements and reporting procedures. To request a sign language or oral interpreter for this visit, call the Public Works Contracts Division at (619) 533-3450 at least 5 Working Days prior to the meeting to ensure availability. The Pre-Bid meeting is scheduled as follows:

**Date: November 30, 2016**  
**Time: 10:00 A.M.**  
**Location: 1010 Second Avenue Suite 1400 (Large Conf. Room)**  
**San Diego, Ca 92101**

Attendance at the Pre-Submittal Meeting will be evidenced by the Bidder's representative's signature on the attendance roster. It is the responsibility of the Bidder's representative to complete and sign the attendance roster.

**9. AWARD PROCESS:**

- 9.1. The Award of this contract is contingent upon the Contractor's compliance with all conditions of Award as stated within these documents and within the Notice of Intent to Award.
- 9.2. Upon acceptance of a Bid, the City will prepare contract documents for execution within approximately 21 days of the date of the Bid opening. The City will then award the Contract within approximately 14 days of receipt of properly signed Contract, bonds, and insurance documents.
- 9.3. This contract will be deemed executed and effective only upon the signing of the Contract by the Mayor or his designee and approval as to form by the City Attorney's Office.
- 9.4. The low Bid will be determined by Base Bid alone.
- 9.5. Once the low bid has been determined, the City may, at its sole discretion, award the contract for the Base bid alone.

**10. SUBMISSION OF QUESTIONS:**

- 10.1. The Public Works Department is responsible for opening, examining, and evaluating the competitive Bids submitted to the City for the acquisition, construction and completion of any public improvement except when otherwise set forth in these documents. Any questions related to this solicitation shall be submitted to:

Public Works Contracts  
1010 Second Avenue, 14<sup>th</sup> Floor  
San Diego, California, 92101  
Attention: Rosa Riego

OR:

[RRiego@sandiego.gov](mailto:RRiego@sandiego.gov)

- 10.2. Questions received less than 14 days prior to the date for opening of Bids may not be considered.
- 10.3. Questions or clarifications deemed by the City to be material shall be answered via issuance of an addendum and posted to the City's online bidding service.
- 10.4. Only questions answered by formal written addenda shall be binding. Oral and other interpretations or clarifications shall be without legal effect. It is the Bidder's responsibility to be informed of any addenda that have been issued and to include all such information in its Bid.

# INSTRUCTIONS TO BIDDERS

## 1. PREQUALIFICATION OF CONTRACTORS:

- 1.1. Contractors submitting a Bid must be pre-qualified for the total amount proposed, including all alternate items, prior to the date of submittal. Bids from contractors who have not been pre-qualified as applicable and Bids that exceed the maximum dollar amount at which contractors are pre-qualified may be deemed **non-responsive** and ineligible for award. Complete information and links to the on-line prequalification application are available at:

<http://www.sandiego.gov/cip/bidopps/prequalification.shtml>

- 1.2. The completed application must be submitted online no later than 2 weeks prior to the bid opening. For additional information or the answer to questions about the prequalification program, contact David Stucky at 619-533-3474 or [dstucky@sandiego.gov](mailto:dstucky@sandiego.gov).
- 1.3. Due to the City's fiduciary requirement to safeguard vendor data, City staff will not be able to provide information regarding contractors' prequalification status over the telephone. Contractors may access real-time information about their prequalification status via their vendor profile on [PlanetBids™](#).

## 2. ELECTRONIC FORMAT RECEIPT AND OPENING OF BIDS: Bids will be received in electronic format (eBids) EXCLUSIVELY at the City of San Diego's electronic bidding (eBidding) site, at: <http://www.sandiego.gov/cip/bidopps/index.shtml> and are due by the date, and time shown on the cover of this solicitation.

- 2.1. BIDDERS MUST BE PRE-REGISTERED with the City's bidding system and possess a system-assigned Digital ID in order to submit and electronic bid.
- 2.2. The City's bidding system will automatically track information submitted to the site including IP addresses, browsers being used and the URLs from which information was submitted. In addition, the City's bidding system will keep a history of every login instance including the time of login, and other information about the user's computer configuration such as the operating system, browser type, version, and more. Because of these security features, Contractors who disable their browsers' cookies will not be able to log in and use the City's bidding system.
- 2.3. The City's electronic bidding system is responsible for bid tabulations. Upon the bidder's or proposer's entry of their bid, the system will ensure that all required fields are entered. **The system will not accept a bid for which any required information is missing.** This includes all necessary pricing, subcontractor listing(s) and any other essential documentation and supporting materials and forms requested or contained in these solicitation documents.

- 2.4. BIDS REMAIN SEALED UNTIL BID DEADLINE. eBids are transmitted into the City's bidding system via hypertext transfer protocol secure (https) mechanism using SSL 128-256 bit security certificates issued from Verisign/Thawte which encrypts data being transferred from client to server. Bids submitted prior to the "Bid Due Date and Time" are not available for review by anyone other than the submitter which has until the "Bid Due Date and Time" to change, rescind or retrieve its proposal should it desire to do so.
- 2.5. BIDS MUST BE SUBMITTED BY BID DUE DATE AND TIME. Once the bid deadline is reached, no further submissions are accepted into the system. Once the Bid Due Date and Time has lapsed, bidders, proposers, the general public, and City staff are able to immediately see the results on line. City staff may then begin reviewing the submissions for responsiveness, EOCP compliance and other issues. The City may require any Bidder to furnish statement of experience, financial responsibility, technical ability, equipment, and references.
- 2.6. RECAPITULATION OF THE WORK. Bids shall not contain any recapitulation of the Work. Conditional Bids may be rejected as being non-responsive. Alternative proposals will not be considered unless called for.
- 2.7. BIDS MAY BE WITHDRAWN by the Bidder only up to the bid due date and time.
  - 2.7.1. Important Note: Submission of the electronic bid into the system may not be instantaneous. Due to the speed and capabilities of the user's internet service provider (ISP), bandwidth, computer hardware and other variables, it may take time for the bidder's submission to upload and be received by the City's eBidding system. It is the bidder's sole responsibility to ensure their bids are received on time by the City's eBidding system. The City of San Diego is not responsible for bids that do not arrive by the required date and time.
- 2.8. ACCESSIBILITY AND AMERICANS WITH DISABILITIES ACT (ADA) COMPLIANCE. : To request a copy of this solicitation in an alternative format, contact the Public Works Contract Specialist listed on the cover of this solicitation at least five (5) working days prior to the Bid/Proposal due date to ensure availability.

### **3. ELECTRONIC BID SUBMISSIONS CARRY FULL FORCE AND EFFECT**

- 3.1. The bidder, by submitting its electronic bid, acknowledges that doing so carries the same force and full legal effect as a paper submission with a longhand (wet) signature.
- 3.2. By submitting an electronic bid, the bidder certifies that the bidder has thoroughly examined and understands the entire Contract Documents (which consist of the plans and specifications, drawings, forms, affidavits and the solicitation documents), and that by submitting the eBid as its bid proposal, the bidder acknowledges, agrees to and is bound by the entire Contract Documents, including any addenda issued thereto, and incorporated by reference in the Contract Documents.

- 3.3. The Bidder, by submitting its electronic bid, agrees to and certifies under penalty of perjury under the laws of the State of California, that the certification, forms and affidavits submitted as part of this bid are true and correct.
- 3.4. The Bidder agrees to the construction of the project as described in Attachment "A-Scope of Work" for the City of San Diego, in accordance with the requirements set forth herein for the electronically submitted prices. The Bidder guarantees the Contract Price for a period of 120 days (90 days for federally funded contracts and contracts valued at \$500,000 or less) from the date of Bid opening. The duration of the Contract Price guarantee shall be extended by the number of days required for the City to obtain all items necessary to fulfill all conditions precedent.
4. **BIDS ARE PUBLIC RECORDS:** Upon receipt by the City, Bids shall become public records subject to public disclosure. It is the responsibility of the respondent to clearly identify any confidential, proprietary, trade secret or otherwise legally privileged information contained within the Bid. General references to sections of the California Public Records Act (PRA) will not suffice. If the Contractor does not provide applicable case law that clearly establishes that the requested information is exempt from the disclosure requirements of the PRA, the City shall be free to release the information when required in accordance with the PRA, pursuant to any other applicable law, or by order of any court or government agency, and the Contractor will hold the City harmless for release of this information.
5. **CONTRACTOR REGISTRATION AND ELECTRONIC REPORTING SYSTEM:**
  - 5.1. **Prior** to the Award of the Contract or Task Order, you and your Subcontractors and Suppliers must register with the City's web-based vendor registration and bid management system. For additional information go to:  
  
<http://www.sandiego.gov/purchasing/bids-contracts/vendorreg.shtml>.
  - 5.2. The City may not award the contract until registration of all subcontractors and suppliers is complete. In the event this requirement is not met within the time frame specified in the Notice of Intent to Award letter, the City reserves the right to rescind the Notice of Award / Intent to Award and to make the award to the next responsive and responsible bidder / proposer.
6. **JOINT VENTURE CONTRACTORS:** Provide a copy of the Joint Venture agreement and the Joint Venture license to the City within 10 Working Days after receiving the Contract forms. See 2-1.1.2, "Joint Venture Contractors" in The WHITEBOOK for details.
7. **PREVAILING WAGE RATES WILL APPLY:** Refer to Attachment D.
8. **SUBCONTRACTING PARTICIPATION PERCENTAGES:** Subcontracting participation percentages apply to this contract. Refer to Attachment E.

**9. INSURANCE REQUIREMENTS:**

- 9.1. All certificates of insurance and endorsements required by the contract are to be provided upon issuance of the City's Notice of Intent to Award letter.
- 9.2. Refer to sections 7-3, "LIABILITY INSURANCE", and 7-4, "WORKERS' COMPENSATION INSURANCE" of the Supplementary Special Provisions (SSP) for the insurance requirements which must be met.

**10. REFERENCE STANDARDS:** Except as otherwise noted or specified, the Work shall be completed in accordance with the following standards:

Title	Edition	Document Number
Standard Specifications for Public Works Construction ("The GREENBOOK") <a href="http://www.greenbookspecs.org/">http://www.greenbookspecs.org/</a>	2015	PWPI070116-01
City of San Diego Standard Specifications for Public Works Construction ("The WHITEBOOK")* <a href="https://www.sandiego.gov/publicworks/edocref/greenbook">https://www.sandiego.gov/publicworks/edocref/greenbook</a>	2015	PWPI070116-02
City of San Diego Standard Drawings* <a href="https://www.sandiego.gov/publicworks/edocref/standarddraw">https://www.sandiego.gov/publicworks/edocref/standarddraw</a>	2016	PWPI070116-03
Citywide Computer Aided Design and Drafting (CADD) Standards <a href="https://www.sandiego.gov/publicworks/edocref/drawings">https://www.sandiego.gov/publicworks/edocref/drawings</a>	2016	PWPI092816-04
California Department of Transportation (CALTRANS) Standard Specifications - <a href="http://www.dot.ca.gov/des/oe/construction-contract-standards.html">http://www.dot.ca.gov/des/oe/construction-contract-standards.html</a>	2015	PWPI092816-05
CALTRANS Standard Plans <a href="http://www.dot.ca.gov/des/oe/construction-contract-standards.html">http://www.dot.ca.gov/des/oe/construction-contract-standards.html</a>	2015	PWPI092816-06
California Manual on Uniform Traffic Control Devices Revision 1 (CA MUTCD Rev 1) - <a href="http://www.dot.ca.gov/trafficops/camutcd/">http://www.dot.ca.gov/trafficops/camutcd/</a>	2014	PWPI092816-07
<b>NOTE:</b> *Available online under Engineering Documents and References at: <a href="http://www.sandiego.gov/publicworks/edocref/index.shtml">http://www.sandiego.gov/publicworks/edocref/index.shtml</a>		

**11. CITY'S RESPONSES AND ADDENDA:** The City, at its discretion, may respond to any or all questions submitted in writing via the City's eBidding web site in the **form of an addendum**. No other responses to questions, oral or written shall be of any force or effect with respect to this solicitation. The changes to the Contract Documents through addenda are made effective as though originally issued with the Bid. The Bidders shall acknowledge the receipt of Addenda at the time of bid submission.

- 12. CITY'S RIGHTS RESERVED:** The City reserves the right to cancel the Notice Inviting Bids at any time, and further reserves the right to reject submitted Bids, without giving any reason for such action, at its sole discretion and without liability. Costs incurred by the Bidder(s) as a result of preparing Bids under the Notice Inviting Bids shall be the sole responsibility of each bidder. The Notice Inviting Bids creates or imposes no obligation upon the City to enter a contract.
- 13. CONTRACT PRICING:** This solicitation is for a Lump Sum contract with Unit Price provisions as set forth herein. The Bidder agrees to perform construction services for the City of San Diego in accordance with these contract documents for the prices listed below. The Bidder further agrees to guarantee the Contract Price for a period of 120 days from the date of Bid opening. The duration of the Contract Price guarantee may be extended, by mutual consent of the parties, by the number of days required for the City to obtain all items necessary to fulfill all contractual conditions.
- 14. SUBCONTRACTOR INFORMATION:**
- 14.1. LISTING OF SUBCONTRACTORS.** In accordance with the requirements provided in the "Subletting and Subcontracting Fair Practices Act" of the California Public Contract Code, the Bidder shall provide the **NAME** and **ADDRESS** of each Subcontractor who will perform work, labor, render services or who specially fabricates and installs a portion [type] of the work or improvement, in an amount in excess of 0.5% of the Contractor's total Bid. The Bidder shall also state within the description, whether the subcontractor is a **CONSTRUCTOR, CONSULTANT** or **SUPPLIER**. The Bidder shall further state within the description, the **PORTION** of the work which will be performed by each subcontractor under this Contract. The Contractor shall list only one Subcontractor for each portion of the Work. The **DOLLAR VALUE** of the total Bid to be performed shall be stated for all subcontractors listed. Failure to comply with this requirement may result in the Bid being rejected as **non-responsive** and ineligible for award. The Bidder's attention is directed to the Special Provisions - General; Paragraph 2-3, "Subcontracts", which stipulates the percent of the Work to be performed with the Bidders' own forces. The Bidder shall list all SLBE, ELBE, DBE, DVBE, MBE, WBE, OBE, SDB, WoSB, HUBZone, and SDVOSB Subcontractors for which Bidders are seeking recognition towards achieving any mandatory, voluntary (or both) subcontracting participation goals.
- 14.2. LISTING OF SUPPLIERS.** Any Bidder seeking the recognition of Suppliers of equipment, materials, or supplies obtained from third party Suppliers towards achieving any mandatory or voluntary (or both) subcontracting participation goals shall provide, at a minimum, the **NAME, LOCATION (CITY)** and the **DOLLAR VALUE** of each supplier. The Bidder will be credited up to 60% of the amount to be paid to the Suppliers for materials and supplies unless vendor manufactures or substantially alters materials and supplies, in which case, 100% will be credited. The Bidder is to indicate within the description whether the listed firm is a supplier or manufacturer. If no indication is provided, the listed firm will be credited at 60% of the listed dollar value for purposes of calculating the Subcontractor Participation Percentage.

- 14.3. **LISTING OF SUBCONTRACTORS OR SUPPLIERS FOR ALTERNATES.** For subcontractors or suppliers to be used on additive or deductive alternate items, in addition to the above requirements, bidder shall further note "ALTERNATE" and alternate item number within the description.
15. **SUBMITTAL OF "OR EQUAL" ITEMS:** See Section 4-1.6, "Trade Names or Equals" in The WHITEBOOK and as amended in the SSP.
16. **AWARD PROCESS:**
- 16.1. The Award of this contract is contingent upon the Contractor's compliance with all conditions precedent to Award.
- 16.2. Upon acceptance of a Bid, the City will prepare contract documents for execution within approximately 21 days of the date of the Bid opening and award the Contract approximately within 7 days of receipt of properly executed Contract, bonds, and insurance documents.
- 16.3. This contract will be deemed executed and effective only upon the signing of the Contract by the Mayor or his designee and approval as to form the City Attorney's Office.
17. **SUBCONTRACT LIMITATIONS:** The Bidder's attention is directed to Standard Specifications for Public Works Construction, Section 2-3, "SUBCONTRACTS" in The GREENBOOK and as amended in the SSP which requires the Contractor to self-perform not less than the specified amount. Failure to comply with this requirement shall render the bid **non-responsive** and ineligible for award.
18. **AVAILABILITY OF PLANS AND SPECIFICATIONS:** Contract Documents may be obtained by visiting the City's website: <http://www.sandiego.gov/cip/>. Plans and Specifications for this contract are also available for review in the office of the City Clerk or Public Works Contracts.
19. **ONLY ONE BID PER CONTRACTOR SHALL BE ACCEPTED:** No person, firm, or corporation shall be allowed to make, file, or be interested in more than one (1) Bid for the same work unless alternate Bids are called for. A person, firm or corporation who has submitted a sub-proposal to a Bidder, or who has quoted prices on materials to a Bidder, is not hereby disqualified from submitting a sub-proposal or quoting prices to other Bidders or from submitting a Bid in its own behalf. Any Bidder who submits more than one bid will result in the rejection of all bids submitted.
20. **SAN DIEGO BUSINESS TAX CERTIFICATE:** The Contractor and Subcontractors, not already having a City of San Diego Business Tax Certificate for the work contemplated shall secure the appropriate certificate from the City Treasurer, Civic Center Plaza, First floor and submit to the Contract Specialist upon request or as specified in the Contract Documents. Tax Identification numbers for both the Bidder and the listed Subcontractors must be submitted on the City provided forms within these documents.



**21. BIDDER'S GUARANTEE OF GOOD FAITH (BID SECURITY):**

- 21.1. For bids \$250,000 and above, bidders shall submit Bid Security at bid time. Bid Security shall be in one of the following forms: a cashier's check, or a properly certified check upon some responsible bank; or an approved corporate surety bond payable to the City of San Diego for an amount of not less than 10% of the total bid amount.
- 21.2. This check or bond, and the monies represented thereby, will be held by the City as a guarantee that the Bidder, if awarded the contract, will in good faith enter into the contract and furnish the required final performance and payment bonds.
- 21.3. The Bidder agrees that in the event of the Bidder's failure to execute this contract and provide the required final bonds, the money represented by the cashier's or certified check will remain the property of the City; and the Surety agrees that it will pay to the City the damages, not exceeding the sum of 10% of the amount of the Bid, that the City may suffer as a result of such failure.
- 21.4. At the time of bid submission, bidders must upload and submit an electronic PDF copy of the aforementioned bid security. Whether in the form of a cashier's check, a properly certified check or an approved corporate surety bond payable to the City of San Diego, the bid security must be uploaded to the City's eBidding system. Within twenty-four (24) hours after the bid due date and time, the first five (5) apparent low bidders must provide the City with the original bid security.
- 21.5. Failure to submit the electronic version of the bid security at the time of bid submission AND failure to provide the original within twenty-four (24) hours may cause the bid to be rejected and deemed **non-responsive**.

**22. AWARD OF CONTRACT OR REJECTION OF BIDS:**

- 22.1. This contract may be awarded to the lowest responsible and reliable Bidder.
- 22.2. Bidders shall complete ALL eBid forms as required by this solicitation. Incomplete eBids will not be accepted.
- 22.3. The City reserves the right to reject any or all Bids, to waive any informality or technicality in Bids received, and to waive any requirements of these specifications as to bidding procedure.
- 22.4. Bidders will not be released on account of their errors of judgment. Bidders may be released only upon receipt by the City within 3 Working Days of the bid opening, written notice from the Bidder which shows proof of honest, credible, clerical error of a material nature, free from fraud or fraudulent intent; and of evidence that reasonable care was observed in the preparation of the Bid.

- 22.5. A bidder who is not selected for contract award may protest the award of a contract to another bidder by submitting a written protest in accordance with the San Diego Municipal Code.
- 22.6. The City of San Diego will not discriminate in the award of contracts with regard to race, religion creed, color, national origin, ancestry, physical handicap, marital status, sex or age.
- 22.7. Each Bid package properly signed as required by these specifications shall constitute a firm offer which may be accepted by the City within the time specified herein.
- 22.8. The City reserves the right to evaluate all Bids and determine the lowest Bidder on the basis of the base bid and any proposed alternates or options as detailed herein.

**23. BID RESULTS:**

- 23.1. The availability of the bids on the City's eBidding system shall constitute the public announcement of the apparent low bidder. In the event that the apparent low bidder is subsequently deemed non-responsive or non-responsible, a notation of such will be made on the eBidding system. The new ranking and apparent low bidder will be adjusted accordingly.
- 23.2. To obtain the bid results, view the results on the City's web site, or request the results by U.S. mail and provide a self-addressed, stamped envelope. If requesting by mail, be sure to reference the bid name and number. The bid tabulations will be mailed to you upon their completion. The results will not be given over the telephone.

**24. THE CONTRACT:**

- 24.1. The Bidder to whom award is made shall execute a written contract with the City of San Diego and furnish good and approved bonds and insurance certificates specified by the City within 14 days after receipt by Bidder of a form of contract for execution unless an extension of time is granted to the Bidder in writing.
- 24.2. If the Bidder takes longer than 14 days to fulfill these requirements, then the additional time taken shall be added to the Bid guarantee. The Contract shall be made in the form adopted by the City, which includes the provision that no claim or suit whatsoever shall be made or brought by Contractor against any officer, agent, or employee of the City for or on account of anything done or omitted to be done in connection with this contract, nor shall any such officer, agent, or employee be liable hereunder.

- 24.3. If the Bidder to whom the award is made fails to enter into the contract as herein provided, the award may be annulled and the Bidder's Guarantee of Good Faith will be subject to forfeiture. An award may be made to the next lowest responsible and reliable Bidder who shall fulfill every stipulation embraced herein as if it were the party to whom the first award was made.
- 24.4. Pursuant to the San Diego City Charter section 94, the City may only award a public works contract to the lowest responsible and reliable Bidder. The City will require the Apparent Low Bidder to (i) submit information to determine the Bidder's responsibility and reliability, (ii) execute the Contract in form provided by the City, and (iii) furnish good and approved bonds and insurance certificates specified by the City within 14 Days, unless otherwise approved by the City, in writing after the Bidder receives notification from the City, designating the Bidder as the Apparent Low Bidder and formally requesting the above mentioned items.
- 24.5. The award of the Contract is contingent upon the satisfactory completion of the above-mentioned items and becomes effective upon the signing of the Contract by the Mayor or designee and approval as to form the City Attorney's Office. If the Apparent Low Bidder does not execute the Contract or submit required documents and information, the City may award the Contract to the next lowest responsible and reliable Bidder who shall fulfill every condition precedent to award. A corporation designated as the Apparent Low Bidder shall furnish evidence of its corporate existence and evidence that the officer signing the Contract and bond for the corporation is duly authorized to do so.
- 25. EXAMINATION OF PLANS, SPECIFICATIONS, AND SITE OF WORK:** The Bidder shall examine carefully the Project Site, the Plans and Specifications, other materials as described in the Special Provisions, Section 2-7, and the proposal forms (e.g., Bidding Documents). The submission of a Bid shall be conclusive evidence that the Bidder has investigated and is satisfied as to the conditions to be encountered, as to the character, quality, and scope of Work, the quantities of materials to be furnished, and as to the requirements of the Bidding Documents Proposal, Plans, and Specifications.
- 26. CITY STANDARD PROVISIONS:** This contract is subject to the following standard provisions. See The WHITEBOOK for details.
- 26.1. The City of San Diego Resolution No. R-277952 adopted on May 20, 1991 for a Drug-Free Workplace.
- 26.2. The City of San Diego Resolution No. R-282153 adopted on June 14, 1993 related to the Americans with Disabilities Act.
- 26.3. The City of San Diego Municipal Code §22.3004 for Contractor Standards.
- 26.4. The City of San Diego's Labor Compliance Program and the State of California Labor Code §§1771.5(b) and 1776.

- 26.5. Sections 1777.5, 1777.6, and 1777.7 of the State of California Labor Code concerning the employment of apprentices by contractors and subcontractors performing public works contracts.
- 26.6. The City's Equal Benefits Ordinance (EBO), Chapter 2, Article 2, Division 43 of The San Diego Municipal Code (SDMC).
- 26.7. The City's Information Security Policy (ISP) as defined in the City's Administrative Regulation 90.63.

**27. PRE-AWARD ACTIVITIES:**

- 27.1. The contractor selected by the City to execute a contract for this Work shall submit the required documentation as specified in the herein and in the Notice of Award. Failure to provide the information as specified may result in the Bid being rejected as **non-responsive**.
- 27.2. The decision that bid is non-responsive for failure to provide the information required within the time specified shall be at the sole discretion of the City.

**PERFORMANCE BOND, LABOR AND MATERIALMEN'S BOND**

---

**FAITHFUL PERFORMANCE BOND AND LABOR AND MATERIALMEN'S BOND:**

\_\_\_\_\_ Portillo Concrete, Inc. \_\_\_\_\_, a corporation, as principal, and \_\_\_\_\_, a corporation authorized to do business in the State of California, as Surety, hereby obligate themselves, their successors and assigns, jointly and severally, to The City of San Diego a municipal corporation in the sum of **Eight Hundred Thirty Six Thousand Two Hundred Fifty Seven Dollars and 40/100 (\$836,257.40)** for the faithful performance of the annexed contract, and in the sum of **Eight Hundred Thirty Six Thousand Two Hundred Fifty Seven Dollars and 40/100 (\$836,257.40)** for the benefit of laborers and materialmen designated below.

**Conditions:**

If the Principal shall faithfully perform the annexed contract with the City of San Diego, California, then the obligation herein with respect to a faithful performance shall be void; otherwise it shall remain in full force.

If the Principal shall promptly pay all persons, firms and corporations furnishing materials for or performing labor in the execution of this contract, and shall pay all amounts due under the California Unemployment Insurance Act then the obligation herein with respect to laborers and materialmen shall be void; otherwise it shall remain in full force.

The obligation herein with respect to laborers and materialmen shall inure to the benefit of all persons, firms and corporations entitled to file claims under the provisions of Article 2. Claimants, (iii) public works of improvement commencing with Civil Code Section 9100 of the Civil Code of the State of California.

Changes in the terms of the annexed contract or specifications accompanying same or referred to therein shall not affect the Surety's obligation on this bond, and the Surety hereby waives notice of same.

The Surety shall pay reasonable attorney's fees should suit be brought to enforce the provisions of this bond.

# Issued in Triplicate

Bond No.: 024067387  
Premium: \$9,113.00

## PERFORMANCE BOND, LABOR AND MATERIALMEN'S BOND

### FAITHFUL PERFORMANCE BOND AND LABOR AND MATERIALMEN'S BOND:

Portillo Concrete, Inc., a corporation, as principal, and  
The Ohio Casualty Insurance Company, a corporation authorized to do  
 business in the State of California, as Surety, hereby obligate themselves, their successors and  
 assigns, jointly and severally, to The City of San Diego a municipal corporation in the sum of  
 Eight hundred thirty-six thousand two hundred fifty-seven & 40/100ths (\$836,257.40) for the faithful performance of the  
 annexed contract, and in the sum of Eight hundred thirty-six thousand two hundred fifty-seven & 40/100ths (\$836,257.40) for the  
 benefit of laborers and materialmen designated below.

#### Conditions:

If the Principal shall faithfully perform the annexed contract with the City of San Diego, California, then the obligation herein with respect to a faithful performance shall be void; otherwise it shall remain in full force.

If the Principal shall promptly pay all persons, firms and corporations furnishing materials for or performing labor in the execution of this contract, and shall pay all amounts due under the California Unemployment Insurance Act then the obligation herein with respect to laborers and materialmen shall be void; otherwise it shall remain in full force.

The obligation herein with respect to laborers and materialmen shall inure to the benefit of all persons, firms and corporations entitled to file claims under the provisions of Article 2. Claimants, (iii) public works of improvement commencing with Civil Code Section 9100 of the Civil Code of the State of California.

Changes in the terms of the annexed contract or specifications accompanying same or referred to therein shall not affect the Surety's obligation on this bond, and the Surety hereby waives notice of same.

The Surety shall pay reasonable attorney's fees should suit be brought to enforce the provisions of this bond.

PERFORMANCE BOND, LABOR AND MATERIALMEN'S BOND (continued)

Dated January 23, 2017

Approved as to Form

Portillo Concrete, Inc.

By:   
Principal

Mario Portillo, President

Printed Name of Person Signing for Principal

Mara W. Elliott, City Attorney

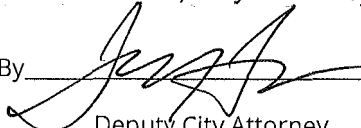
By:   
Deputy City Attorney

The Ohio Casualty Insurance Company

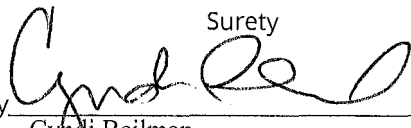
By:   
Surety  
Cyndi Beilman  
Attorney-in-fact

Approved:

790 The City Drive South, Ste. 200

Local Address of Surety

Orange, CA 92868

Local Address (City, State) of Surety

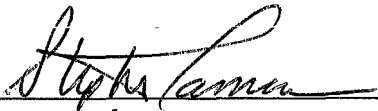
By:   
Stephen Samara  
Principal Contract Specialist  
Public Works Department

858-255-3988

Local Telephone No. of Surety

Premium \$ 9,113.00

Bond No. 024067387

# CALIFORNIA ALL-PURPOSE ACKNOWLEDGMENT

A notary public or other officer completing this certificate verifies only the identity of the individual who signed the document to which this certificate is attached, and not the truthfulness, accuracy, or validity of that document.

STATE OF CALIFORNIA

County of San Diego }

On January 23, 2017 before me, Dana L. Michaelis, Notary Public,  
Date Insert Name of Notary exactly as it appears on the official seal

personally appeared Cyndi Beilman

Name(s) of Signer(s)



Place Notary Seal Above

who proved to me on the basis of satisfactory evidence to be the person(s) whose name(s) is/~~are~~ subscribed to the within instrument and acknowledged to me that ~~he~~/she/~~they~~ executed the same in ~~his~~/her/~~their~~ authorized capacity(ies), and that by ~~his~~/her/~~their~~ signature(s) on the instrument the person(s), or the entity upon behalf of which the person(s) acted, executed the instrument.

I certify under PENALTY OF PERJURY under the laws of the State of California that the foregoing paragraph is true and correct.

Witness my hand and official seal.

Signature

Dana L. Michaelis  
Signature of Notary Public Dana L. Michaelis

## OPTIONAL

Though the information below is not required by law, it may prove valuable to persons relying on the document and could prevent fraudulent removal and reattachment of the form to another document.

### Description of Attached Document

Title or Type of Document: \_\_\_\_\_

Document Date: \_\_\_\_\_ Number of Pages: \_\_\_\_\_

Signer(s) Other Than Named Above: \_\_\_\_\_

### Capacity(ies) Claimed by Signer(s)

Signer's Name: \_\_\_\_\_

- Individual
- Corporate Officer — Title(s): \_\_\_\_\_
- Partner  Limited  General
- Attorney in Fact
- Trustee
- Guardian or Conservator
- Other: \_\_\_\_\_

Signer is Representing: \_\_\_\_\_

RIGHT THUMBPRINT  
OF SIGNER

Top of thumb here

Signer's Name: \_\_\_\_\_

- Individual
- Corporate Officer — Title(s): \_\_\_\_\_
- Partner  Limited  General
- Attorney in Fact
- Trustee
- Guardian or Conservator
- Other: \_\_\_\_\_

Signer is Representing: \_\_\_\_\_

RIGHT THUMBPRINT  
OF SIGNER

Top of thumb here



**THIS POWER OF ATTORNEY IS NOT VALID UNLESS IT IS PRINTED ON RED BACKGROUND.**

This Power of Attorney limits the acts of those named herein, and they have no authority to bind the Company except in the manner and to the extent herein stated.

Certificate No. 7527098

Liberty Mutual Insurance Company  
The Ohio Casualty Insurance Company West American Insurance Company

**POWER OF ATTORNEY**

KNOWN ALL PERSONS BY THESE PRESENTS: That The Ohio Casualty Insurance Company is a corporation duly organized under the laws of the State of New Hampshire, that Liberty Mutual Insurance Company is a corporation duly organized under the laws of the State of Massachusetts, and West American Insurance Company is a corporation duly organized under the laws of the State of Indiana (herein collectively called the "Companies"), pursuant to and by authority herein set forth, does hereby name, constitute and appoint, Anne Wright; Cyndi Beilman; Dana Michaelis

all of the city of La Mesa, state of CA each individually if there be more than one named, its true and lawful attorney-in-fact to make, execute, seal, acknowledge and deliver, for and on its behalf as surety and as its act and deed, any and all undertakings, bonds, recognizances and other surety obligations, in pursuance of these presents and shall be as binding upon the Companies as if they have been duly signed by the president and attested by the secretary of the Companies in their own proper persons.

IN WITNESS WHEREOF, this Power of Attorney has been subscribed by an authorized officer or official of the Companies and the corporate seals of the Companies have been affixed thereto this 28th day of October, 2016.



The Ohio Casualty Insurance Company  
Liberty Mutual Insurance Company  
West American Insurance Company

By: David M. Carey  
David M. Carey, Assistant Secretary

STATE OF PENNSYLVANIA ss  
COUNTY OF MONTGOMERY

On this 28th day of October, 2016, before me personally appeared David M. Carey, who acknowledged himself to be the Assistant Secretary of Liberty Mutual Insurance Company, The Ohio Casualty Company, and West American Insurance Company, and that he, as such, being authorized so to do, execute the foregoing instrument for the purposes therein contained by signing on behalf of the corporations by himself as a duly authorized officer.

IN WITNESS WHEREOF, I have hereunto subscribed my name and affixed my notarial seal at King of Prussia, Pennsylvania, on the day and year first above written.



COMMONWEALTH OF PENNSYLVANIA  
Notarial Seal  
Teresa Pastella, Notary Public  
Upper Merion Twp., Montgomery County  
My Commission Expires March 28, 2017  
Member, Pennsylvania Association of Notaries

By: Teresa Pastella  
Teresa Pastella, Notary Public

This Power of Attorney is made and executed pursuant to and by authority of the following By-laws and Authorizations of The Ohio Casualty Insurance Company, Liberty Mutual Insurance Company, and West American Insurance Company which resolutions are now in full force and effect reading as follows:

**ARTICLE IV – OFFICERS** – Section 12. Power of Attorney. Any officer or other official of the Corporation authorized for that purpose in writing by the Chairman or the President, and subject to such limitation as the Chairman or the President may prescribe, shall appoint such attorneys-in-fact, as may be necessary to act in behalf of the Corporation to make, execute, seal, acknowledge and deliver as surety any and all undertakings, bonds, recognizances and other surety obligations. Such attorneys-in-fact, subject to the limitations set forth in their respective powers of attorney, shall have full power to bind the Corporation by their signature and execution of any such instruments and to attach thereto the seal of the Corporation. When so executed, such instruments shall be as binding as if signed by the President and attested to by the Secretary. Any power or authority granted to any representative or attorney-in-fact under the provisions of this article may be revoked at any time by the Board, the Chairman, the President or by the officer or officers granting such power or authority.

**ARTICLE XIII – Execution of Contracts – SECTION 5. Surety Bonds and Undertakings.** Any officer of the Company authorized for that purpose in writing by the chairman or the president, and subject to such limitations as the chairman or the president may prescribe, shall appoint such attorneys-in-fact, as may be necessary to act in behalf of the Company to make, execute, seal, acknowledge and deliver as surety any and all undertakings, bonds, recognizances and other surety obligations. Such attorneys-in-fact subject to the limitations set forth in their respective powers of attorney, shall have full power to bind the Company by their signature and execution of any such instruments and to attach thereto the seal of the Company. When so executed such instruments shall be as binding as if signed by the president and attested by the secretary.

**Certificate of Designation** – The President of the Company, acting pursuant to the Bylaws of the Company, authorizes David M. Carey, Assistant Secretary to appoint such attorneys-in-fact as may be necessary to act on behalf of the Company to make, execute, seal, acknowledge and deliver as surety any and all undertakings, bonds, recognizances and other surety obligations.

**Authorization** – By unanimous consent of the Company's Board of Directors, the Company consents that facsimile or mechanically reproduced signature of any assistant secretary of the Company, wherever appearing upon a certified copy of any power of attorney issued by the Company in connection with surety bonds, shall be valid and binding upon the Company with the same force and effect as though manually affixed.

I, Renee C. Llewellyn, the undersigned, Assistant Secretary, The Ohio Casualty Insurance Company, Liberty Mutual Insurance Company, and West American Insurance Company do hereby certify that the original power of attorney of which the foregoing is a full, true and correct copy of the Power of Attorney executed by said Companies, is in full force and effect and has not been revoked.

IN TESTIMONY WHEREOF, I have hereunto set my hand and affixed the seals of said Companies this 23rd day of January, 2017.



By: Renee C. Llewellyn  
Renee C. Llewellyn, Assistant Secretary

Not valid for mortgage, note, loan, letter of credit, currency rate, interest rate or residual value guarantees.

To confirm the validity of this Power of Attorney call 1-610-832-8240 between 9:00 am and 4:30 pm EST on any business day.

## ATTACHMENTS

**ATTACHMENT A**  
**SCOPE OF WORK**

## SCOPE OF WORK

1. **SCOPE OF WORK:** Furnish all labor, materials, equipment, services, and construction for the removal, replacement and repair of damaged sidewalks and tree-damaged sidewalks, curb and gutters, curb ramps and driveways as noted, and required tree services to mitigate impact of tree on streets, sidewalks, and surfacing drainage.

1.1. The Work shall be performed in accordance with:

1.1.1. The Notice Inviting Bids, Appendix E and Appendix F, inclusive.

2. **ESTIMATED CONSTRUCTION COST:** The City's estimated construction cost for this project is **\$901,000**.

3. **LOCATION OF WORK:** The location of the Work is as follows:

**See Appendix E – Locations Maps**

**See Appendix F – Locations List**

4. **CONTRACT TIME:** The Contract Time for completion of the Work, including the Plant Establishment Period, shall be **120 Working Days**.

4.1. **CONTRACTOR'S LICENSE CLASSIFICATION:** In accordance with the provisions of California Law, the Contractor shall possess valid, appropriate licenses at the time that the Bid is submitted. Failure to possess the specified licenses may render the Bid as **non-responsive** and ineligible for award.

4.2. The City has determined that the following licensing classifications are required for this contract:

Option	Classifications
1	A or
2	C8 or
3	C-12

4.3. The Bidder shall satisfy the licensing requirement by meeting **at least** one of the listed options.

**ATTACHMENT B**  
**INTENTIONALLY LEFT BLANK**

**ATTACHMENT C**  
**INTENTIONALLY LEFT BLANK**

**ATTACHMENT D**  
**PREVAILING WAGES**

**ATTACHMENT D**  
**PREVAILING WAGES**

1. **PREVAILING WAGE RATES:** Pursuant to San Diego Municipal Code section 22.3019, construction, alteration, demolition, repair and maintenance work performed under this Contract is subject to State prevailing wage laws. For construction work performed under this Contract cumulatively exceeding \$25,000 and for alteration, demolition, repair and maintenance work performed under this Contract cumulatively exceeding \$15,000, the Contractor and its subcontractors shall comply with State prevailing wage laws including, but not limited to, the requirements listed below.
  - 1.1. **Compliance with Prevailing Wage Requirements.** Pursuant to sections 1720 through 1861 of the California Labor Code, the Contractor and its subcontractors shall ensure that all workers who perform work under this Contract are paid not less than the prevailing rate of per diem wages as determined by the Director of the California Department of Industrial Relations (DIR). This includes work performed during the design and preconstruction phases of construction including, but not limited to, inspection and land surveying work.
    - 1.1.1. Copies of such prevailing rate of per diem wages are on file at the City and are available for inspection to any interested party on request. Copies of the prevailing rate of per diem wages also may be found at <http://www.dir.ca.gov/OPRL/DPreWageDetermination.htm>. Contractor and its subcontractors shall post a copy of the prevailing rate of per diem wages determination at each job site and shall make them available to any interested party upon request.
    - 1.1.2. The wage rates determined by the DIR refer to expiration dates. If the published wage rate does not refer to a predetermined wage rate to be paid after the expiration date, then the published rate of wage shall be in effect for the life of this Contract. If the published wage rate refers to a predetermined wage rate to become effective upon expiration of the published wage rate and the predetermined wage rate is on file with the DIR, such predetermined wage rate shall become effective on the date following the expiration date and shall apply to this Contract in the same manner as if it had been published in said publication. If the predetermined wage rate refers to one or more additional expiration dates with additional predetermined wage rates, which expiration dates occur during the life of this Contract, each successive predetermined wage rate shall apply to this Contract on the date following the expiration date of the previous wage rate. If the last of such predetermined wage rates expires during the life of this Contract, such wage rate shall apply to the balance of the Contract.
  - 1.2. **Penalties for Violations.** Contractor and its subcontractors shall comply with California Labor Code section 1775 in the event a worker is paid less than the prevailing wage rate for the work or craft in which the worker is employed.



- 1.3. Payroll Records.** Contractor and its subcontractors shall comply with California Labor Code section 1776, which generally requires keeping accurate payroll records, verifying and certifying payroll records, and making them available for inspection. Contractor shall require its subcontractors to also comply with section 1776. Contractor and its subcontractors shall submit weekly certified payroll records online via the City's web-based Labor Compliance Program. Contractor is responsible for ensuring its subcontractors submit certified payroll records to the City.
- 1.3.1.** For contracts entered into on or after April 1, 2015, Contractor and their subcontractors shall furnish records specified in Labor Code section 1776 directly to the Labor Commissioner in the manner required by Labor Code section 1771.4.
- 1.4. Apprentices.** Contractor and its subcontractors shall comply with California Labor Code sections 1777.5, 1777.6 and 1777.7 concerning the employment and wages of apprentices. Contractor is held responsible for the compliance of their subcontractors with sections 1777.5, 1777.6 and 1777.7.
- 1.5. Working Hours.** Contractor and their subcontractors shall comply with California Labor Code sections 1810 through 1815, including but not limited to: (i) restrict working hours on public works contracts to eight hours a day and forty hours a week, unless all hours worked in excess of 8 hours per day are compensated at not less than 1½ times the basic rate of pay; and (ii) specify penalties to be imposed on design professionals and subcontractors of \$25 per worker per day for each day the worker works more than 8 hours per day and 40 hours per week in violation of California Labor Code sections 1810 through 1815.
- 1.6. Required Provisions for Subcontracts.** Contractor shall include at a minimum a copy of the following provisions in any contract they enter into with a subcontractor: California Labor Code sections 1771, 1771.1, 1775, 1776, 1777.5, 1810, 1813, 1815, 1860 and 1861.
- 1.7. Labor Code Section 1861 Certification.** Contractor in accordance with California Labor Code section 3700 is required to secure the payment of compensation of its employees and by signing this Contract, Contractor certifies that "I am aware of the provisions of Section 3700 of the California Labor Code which require every employer to be insured against liability for workers' compensation or to undertake self-insurance in accordance with the provisions of that code, and I will comply with such provisions before commencing the performance of the work of this Contract."
- 1.8. Labor Compliance Program.** The City has its own Labor Compliance Program authorized in August 2011 by the DIR. The City will withhold contract payments when payroll records are delinquent or deemed inadequate by the City or other governmental entity, or it has been established after an investigation by the City or other governmental entity that underpayment(s) have occurred. For questions

or assistance, please contact the City of San Diego's Equal Opportunity Contracting Department at 619-236-6000.

**1.9. Contractor and Subcontractor Registration Requirements.** This project is subject to compliance monitoring and enforcement by the DIR. As of March 1, 2015, no contractor or subcontractor may be listed on a bid or proposal for a public works project unless registered with the DIR pursuant to Labor Code section 1725.5. As of April 1, 2015, a contractor or subcontractor shall not be qualified to bid on, be listed in a bid proposal, or enter into any contract for public work, unless currently registered and qualified to perform public work pursuant to Labor Code section 1725.5. By submitting a bid or proposal to the City, Contractor is certifying that he or she has verified that all subcontractors used on this public work project are registered with the DIR in compliance with Labor Code sections 1771.1 and 1725.5, and Contractor shall provide proof of registration to the City upon request.

**1.9.1.** A Contractor's inadvertent error in listing a subcontractor who is not registered pursuant to Labor Code section 1725.5 in response to a solicitation shall not be grounds for filing a bid protest or grounds for considering the bid non-responsive provided that any of the following apply: (1) the subcontractor is registered prior to bid opening; (2) within twenty-four hours after the bid opening, the subcontractor is registered and has paid the penalty registration fee specified in Labor Code section 1725.5; or (3) the subcontractor is replaced by another registered subcontractor pursuant to Public Contract Code section 4107.

**ATTACHMENT E**  
**SUPPLEMENTARY SPECIAL PROVISIONS**

## SUPPLEMENTARY SPECIAL PROVISIONS

The following Supplementary Special Provisions (SSP) modifies the following documents:

- 1) The **2015 Edition** of the Standard Specifications for Public Works Construction (The "GREENBOOK") currently in effect.
  - 2) The **2015 Edition** of the City of San Diego Standard Specifications for Public Works Construction (The "WHITEBOOK").
    - a) General Provisions (A) for all Contracts.
- 

### SECTION 1 – TERMS, DEFINITIONS, ABBREVIATIONS, UNITS OF MEASURE, AND SYMBOLS

- 1-2 TERMS AND DEFINITIONS.** To the City Supplement, item 54, "Normal Working Hours", ADD the following:

The **Normal Working Hours** are 7:30 AM to 3:30 PM.

### SECTION 2 - SCOPE AND CONTROL OF WORK

- 2-3.2 Self Performance.** DELETE in its entirety and SUBSTITUTE with the following:

1. You shall perform, with your own organization, Contract Work amounting to at least 50% of the base Bid.

- 2-14.3 Coordination.** To the City Supplement, ADD the following:

2. Coordination will be done by the Contractor and will be made aware of other projects impacting the sidewalk work periodically during the construction.

- 2-16 CONTRACTOR REGISTRATION AND ELECTRONIC REPORTING SYSTEM.** To the City Supplement, item 1, DELETE in its entirety.

### SECTION 4 - CONTROL OF MATERIALS

- 4-1.3.6 Preapproved Materials.** To the City Supplement, ADD the following:

3. You shall submit in writing a list of all products to be incorporated in the Work that are on the AML.

**4-1.6 Trade Names or Equals.** To the City Supplement, ADD the following:

11. You shall submit your list of proposed substitutions for an "equal" item **no less than 15 Working Days prior to the Bid due date** and on the City's Product Submittal Form available at:

<http://www.sandiego.gov/publicworks/edocref/index.shtml>

## **SECTION 5 - UTILITIES**

**5-2 PROTECTION.** To the City Supplement, item 2, ADD the following:

- g) Refer to Appendix "J" for more information on the protection of AMI devices.

## **SECTION 6 - PROSECUTION, PROGRESS AND ACCEPTANCE OF WORK**

**6-1.1 Construction Schedule.** To item 20, ADD the following:

The 90 Calendar Day for the Plant Establishment Period is included in the stipulated Contract Time.

**ADD:**

**6-3.2.1.1 Environmental Document.**

1. The City of San Diego Environmental Analysis Section (EAS) of the Development Services Department has prepared a Notice of Exemption for Sidewalk Replacement Group 1601, as referenced in the Contract Appendix. You shall comply with all requirements of the Notice of Exemption as set forth in Appendix A.
2. Compliance with the City's environmental document shall be included in the Contract Price.

**6-7.1 General.** To the City Supplement, item 3, ADD the following:

- d) 30 Days for full depth asphalt final mill and resurfacing work required per SDG-107.

## SECTION 7 - RESPONSIBILITIES OF THE CONTRACTOR

**7-3 INSURANCE.** DELETE in its entirety and SUBSTITUTE with the following:

**7-3 INSURANCE.**

1. The insurance provisions herein shall not be construed to limit your indemnity obligations contained in the Contract.

**7-3.1 Policies and Procedures.**

1. You shall procure the insurance described below, at its sole cost and expense, to provide coverage against claims for loss including injuries to persons or damage to property, which may arise out of or in connection with the performance of the Work by you, your agents, representatives, officers, employees or Subcontractors.
2. Insurance coverage for property damage resulting from your operations is on a replacement cost valuation. The market value will not be accepted.
3. You shall maintain this insurance for the duration of this Contract and at all times thereafter when you are correcting, removing, or replacing Work in accordance with this Contract. Your liabilities under the Contract, e.g., your indemnity obligations, is not deemed limited to the insurance coverage required by this Contract.
4. The payment for insurance shall be included in the Contract Price as bid by you. Except as specifically agreed to by the City in writing, you are not entitled to any additional payment. Do not begin any Work under this Contract until you have provided and the City has approved all required insurance.
5. Policies of insurance shall provide that the City is entitled to 30 Days (10 Days for cancellation due to non-payment of premium) prior written notice of cancellation or non-renewal of the policy. Maintenance of specified insurance coverage is a material element of the Contract. Your failure to maintain or renew coverage or to provide evidence of renewal during the term of the Contract may be treated by the City as a material breach of the Contract.

**7-3.2 Types of Insurance.**

**7-3.2.1 Commercial General Liability Insurance.**

1. Commercial General Liability Insurance shall be written on the current version of the ISO Occurrence form CG 00 01 07 98 or an equivalent form providing coverage at least as broad.

2. The policy shall cover liability arising from premises and operations, XCU (explosions, underground, and collapse), independent contractors, products/completed operations, personal injury and advertising injury, bodily injury, property damage, and liability assumed under an insured's contract (including the tort liability of another assumed in a business contract).
3. There shall be no endorsement or modification limiting the scope of coverage for either "insured vs. insured" claims or contractual liability. You shall maintain the same or equivalent insurance for at least 10 years following completion of the Work.
4. All costs of defense shall be outside the policy limits. Policy coverage shall be in liability limits of not less than the following:

<u>General Annual Aggregate Limit</u>	<u>Limits of Liability</u>
Other than Products/Completed Operations	\$2,000,000
Products/Completed Operations Aggregate Limit	\$2,000,000
Personal Injury Limit	\$1,000,000
Each Occurrence	\$1,000,000

**7-3.2.2 Commercial Automobile Liability Insurance.**

1. You shall provide a policy or policies of Commercial Automobile Liability Insurance written on the current version of the ISO form CA 00 01 12 90 or later version or equivalent form providing coverage at least as broad in the amount of \$1,000,000 combined single limit per accident, covering bodily injury and property damage for owned, non-owned, and hired automobiles ("Any Auto").
2. All costs of defense shall be outside the limits of the policy.

**7-3.3 Rating Requirements.** Except for the State Compensation Insurance Fund, all insurance required by this Contract as described herein shall be carried only by responsible insurance companies with a rating of, or equivalent to, at least "A-, VI" by A.M. Best Company, that are authorized by the California Insurance Commissioner to do business in the State, and that have been approved by the City.

**7-3.3.1 Non-Admitted Carriers.** The City will accept insurance provided by non-admitted, "surplus lines" carriers only if the carrier is authorized to do business in the State and is included on the List of Approved Surplus Lines Insurers (LASLI list).

All policies of insurance carried by non-admitted carriers shall be subject to all of the requirements for policies of insurance provided by admitted carriers described herein.

**7-3.4 Evidence of Insurance.** Furnish to the City documents e.g., certificates of insurance and endorsements evidencing the insurance required herein, and furnish renewal documentation prior to expiration of this insurance. Each required document shall be signed by the insurer or a person authorized by the insurer to bind coverage on its behalf. We reserve the right to require complete, certified copies of all insurance policies required herein.

**7-3.5 Policy Endorsements.**

**7-3.5.1 Commercial General Liability Insurance.**

**7-3.5.1.1 Additional Insured.**

1. You shall provide at your expense policy endorsement written on the current version of the ISO Occurrence form CG 20 10 11 85 or an equivalent form providing coverage at least as broad.
2. To the fullest extent allowed by law e.g., California Insurance Code §11580.04, the policy shall be endorsed to include the City and its respective elected officials, officers, employees, agents, and representatives as additional insured.
3. The additional insured coverage for projects for which the Engineer's Estimate is \$1,000,000 or more shall include liability arising out of:
  - a) Ongoing operations performed by you or on your behalf,
  - b) your products,
  - c) your Work, e.g., your completed operations performed by you or on your behalf, or
  - d) premises owned, leased, controlled, or used by you.
4. The additional insured coverage for projects for which the Engineer's Estimate is less than \$1,000,000 shall include liability arising out of:
  - a) Ongoing operations performed by you or on your behalf,
  - b) your products, or
  - c) premises owned, leased, controlled, or used by you.

**7-3.5.1.2 Primary and Non-Contributory Coverage.** The policy shall be endorsed to provide that the coverage with respect to operations, including the completed operations, if appropriate, of the Named Insured is primary to any insurance or self-insurance of the City and its elected officials, officers, employees, agents and representatives. Further, it shall provide that any insurance maintained by the City and its elected officials, officers, employees, agents and representatives shall be in excess of your insurance and shall not contribute to it.



**7-3.5.1.3 Project General Aggregate Limit.** The policy or policies shall be endorsed to provide a Designated Construction Project General Aggregate Limit that will apply only to the Work. Only claims payments which arise from the Work shall reduce the Designated Construction Project General Aggregate Limit. The Designated Construction Project General Aggregate Limit shall be in addition to the aggregate limit provided for the products-completed operations hazard.

**7-3.5.2 Commercial Automobile Liability Insurance.**

**7-3.5.2.1 Additional Insured.** Unless the policy or policies of Commercial Auto Liability Insurance are written on an ISO form CA 00 01 12 90 or a later version of this form or equivalent form providing coverage at least as broad, the policy shall be endorsed to include the City and its respective elected officials, officers, employees, agents, and representatives as additional insured, with respect to liability arising out of automobiles owned, leased, hired or borrowed by you or on your behalf. This endorsement is limited to the obligations permitted by California Insurance Code §11580.04.

**7-3.6 Deductibles and Self-Insured Retentions.** You shall pay for all deductibles and self-insured retentions. You shall disclose deductibles and self-insured retentions to the City at the time the evidence of insurance is provided.

**7-3.7 Reservation of Rights.** The City reserves the right, from time to time, to review your insurance coverage, limits, deductibles and self-insured retentions to determine if they are acceptable to the City. The City will reimburse you, without overhead, profit, or any other markup, for the cost of additional premium for any coverage requested by the Engineer but not required by this Contract.

**7-3.8 Notice of Changes to Insurance.** You shall notify the City 30 Days prior to any material change to the policies of insurance provided under this Contract.

**7-3.9 Excess Insurance.** Policies providing excess coverage shall follow the form of the primary policy or policies e.g., all endorsements.

**7-4 NOT USED.** DELETE in its entirety and SUBSTITUTE with the following:

**7-4 WORKERS' COMPENSATION INSURANCE AND EMPLOYERS LIABILITY INSURANCE.**

1. In accordance with the provisions of §3700 of the California Labor Code, you shall provide at your expense Workers' Compensation Insurance and Employers Liability Insurance to protect you against all claims under applicable state workers compensation laws. The City, its elected officials, and employees will not be responsible for any claims in law or equity occasioned by your failure to comply with the requirements of this section.

2. Limits for this insurance shall be not less than the following:

<u>Workers' Compensation</u>	<u>Statutory Employers Liability</u>
------------------------------	--------------------------------------

Bodily Injury by Accident	\$1,000,000 each accident
Bodily Injury by Disease	\$1,000,000 each employee
Bodily Injury by Disease	\$1,000,000 policy limit

3. By signing and returning the Contract you certify that you are aware of the provisions of §3700 of the Labor Code which requires every employer to be insured against liability for worker's compensation or to undertake self-insurance in accordance with the provisions of that code and you shall comply with such provisions before commencing the Work as required by §1861 of the California Labor Code.

**7-4.1. Waiver of Subrogation.** The policy or policies shall be endorsed to provide that the insurer will waive all rights of subrogation against the City and its respective elected officials, officers, employees, agents, and representatives for losses paid under the terms of the policy or policies and which arise from Work performed by the Named Insured for the City.

**7-8.6 Water Pollution Control.** To the City Supplement, ADD the following:

6. Based on a preliminary assessment by the City, this Contract is subject to WPCP.

**7-20 ELECTRONIC COMMUNICATION.** To the City Supplement, ADD the following:

2. Virtual Project Manager shall be used on this Contract.

**7-21.1 General.** To the City Supplement, item 3, DELETE in its entirety and SUBSTITUTE with the following:

3. During the construction phase of projects, the minimum waste management reduction goal is 90% of the inert material (a material not subject to decomposition such as concrete, asphalt, brick, rock, block, dirt, metal, glass, and etc.) and 65% of the remaining project waste. You shall provide appropriate documentation, including a Waste Management Form attached as an appendix, and evidence of recycling and reuse of materials to meet the waste reduction goals specified.

## SECTION 303 -CONCRETE AND MASONRY

**303-5.9**      **Payment.** To the City Supplement, ADD the following:

7. The payment for the replacement of existing sidewalks shall be included in the bid price per SF (square footage) in the Bid item "Remove and Replace Existing Sidewalk" for the total area replaced and no additional payment shall be made regardless of the number of replacements completed. No payment shall be made for areas of over-excavation or outside of scope of work unless previously approved by the Engineer. No payment for sidewalk replacement will be made when the damage is due to the Contractor's failure to protect existing improvements.
8. The payment for the removal and replacement of curb and gutter shall be included in the Bid item "Remove and Replace Curb and Gutter" and shall be paid on a linear foot basis.

## SECTION 304 -METAL FABRICATION AND CONSTRUCTION

**304-5**      **PAYMENT.** To the City Supplement, REVISE section "**304-5**" to "**304-6**".

### EQUAL OPPORTUNITY CONTRACTING PROGRAM (EOCP) SECTION A - GENERAL REQUIREMENTS

**4.1**      **Nondiscrimination in Contracting Ordinance.** To the City Supplement, subsection 4.1.1, paragraph (2), sentence (1), DELETE in its entirety and SUBSTITUTE with the following:

You shall not discriminate on the basis of race, gender, gender expression, gender identity, religion, national origin, ethnicity, sexual orientation, age, or disability in the solicitation, selection, hiring, or treatment of subcontractors, vendors, or suppliers.

### END OF SUPPLEMENTARY SPECIAL PROVISIONS (SSP)

**SUPPLEMENTARY SPECIAL PROVISIONS**

**APPENDICES**

**APPENDIX A**  
**NOTICE OF EXEMPTION**

**NOTICE OF EXEMPTION**

(Check one or both)

TO:  RECORDER/COUNTY CLERK  
P.O. Box 1750, MS A-33  
1600 PACIFIC HWY, ROOM 260  
SAN DIEGO, CA 92101-2422

FROM: CITY OF SAN DIEGO  
PLANNING DEPARTMENT  
1010 SECOND AVENUE, SUITE 1200  
MS 413  
SAN DIEGO, CA 92101

OFFICE OF PLANNING AND RESEARCH  
1400 TENTH STREET, ROOM 121  
SACRAMENTO, CA 95814

PROJECT NO.: N/A

PROJECT TITLE: Sidewalk Replacement Group 1601

PROJECT LOCATION-SPECIFIC: See Attachment "Location List" for specific locations

PROJECT LOCATION-CITY/COUNTY: San Diego/San Diego

DESCRIPTION OF NATURE AND PURPOSE OF THE PROJECT: The project involves furnishing all labor, materials, equipment, services and construction for the removal, replacement and repair of tree related and non-tree related damaged sidewalks, curb & gutters, curb ramps and driveways, as well as required tree services to mitigate impact of trees on streets, sidewalks, and surface drainage. All work would occur within the public right-of-way or previously disturbed areas only. Best Management Practices (BMPs) as well as Traffic Control Plan (TCP) would be implemented throughout construction.

NAME OF PUBLIC AGENCY APPROVING PROJECT: City of San Diego

NAME OF PERSON OR AGENCY CARRYING OUT PROJECT: Transportation and Storm Water Department  
Contact: Dlluvan Piromari, 2781 Caminito Chollas, San Diego, CA 92105, (619) 527-8034

EXEMPT STATUS: (CHECK ONE)

- MINISTERIAL (SEC. 21080(b)(1); 15268);
- DECLARED EMERGENCY (SEC. 21080(b)(3); 15269(a));
- EMERGENCY PROJECT (SEC. 21080(b)(4); 15269 (b)(c))
- CATEGORICAL EXEMPTION: (SEC. 15301 [EXISTING FACILITIES]; SEC. 15303 [NEW CONSTRUCTION OR CONVERSION OF SMALL STRUCTURES])
- STATUTORY EXEMPTION:

REASONS WHY PROJECT IS EXEMPT: The City of San Diego conducted an environmental review and determined the project is exempt from CEQA pursuant to State CEQA Guidelines Section 15301, Existing Facilities, which allows for, among other activities, minor alteration of existing public or private facilities, involving negligible or no expansion of use, such as work for existing highways and streets, sidewalks, gutters, bicycle and pedestrian trails, including grading rights of way for the purpose of public safety; and when the project does not trigger any of the exceptions to the exemptions listed in CEQA Guidelines §15300.2.

LEAD AGENCY CONTACT PERSON: REBECCA MALONE

TELEPHONE: (619) 446-5371

IF FILED BY APPLICANT:

1. ATTACH CERTIFIED DOCUMENT OF EXEMPTION FINDING.
2. HAS A NOTICE OF EXEMPTION BEEN FILED BY THE PUBLIC AGENCY APPROVING THE PROJECT?  
 YES       NO

IT IS HEREBY CERTIFIED THAT THE CITY OF SAN DIEGO HAS DETERMINED THE ABOVE ACTIVITY TO BE EXEMPT FROM CEQA

*Rebecca Malone* SENIOR PLANNER

September 14, 2016.

SIGNATURE/TITLE

DATE

CHECK ONE:

- SIGNED BY LEAD AGENCY  
 SIGNED BY APPLICANT

DATE RECEIVED FOR FILING WITH COUNTY CLERK OR OPR:

LOCATION
5935 HUGHES ST
5902 HUGHES ST
5924 Hughes St
5934 Hughes St
5954 Hughes St
5980 Hughes St
A/F 6005 HUGHES ST
3920 FAIRCROSS PL
5803 REDWOOD ST ON JJANITA ST
2542 54th St
A/F 2639 Balsa St
COLLEGE GROVE DR (350FT E OF CHOLLAS STATION RD)
COLLEGE GROVE DR (1/2 MILE E OF CHOLLAS STATION RD)
A/F 2310 BLACKTON DR
2514 54TH (W FTG) ST
2436 54th St (Frontage)
2606 54TH (W FTG) ST
2309 Blackton Dr
5204 Oak Park Dr
5200 MAPLE ST
1601 KELTON RD (ON BETHUNE CT)
5632 KELTON PL
A/F 1102 47TH ST
A/F 1122 47TH ST
1100 47TH ST (@ C STREET, E OF 47TH)
A/F 1324 KELTON RD
5740 Old Memory Ln
5740 OLD MEMORYLN
5891 OLD MEMORYLN
740 COTTON ST
A/F 950 47th St
1034 47TH ST
1005 47TH ST (350FT E OF 47TH ON HILLTOP DR)
NE OF 47TH ST & HILLTOP DR
A/F 1014 47TH ST
HILLTOP DR & DUVAL ST (E OF DUVAL ON S HILLTOP DR)
A/F 4927 HILLTOP DR
A/F 4919 Hilltop Dr
HILLTOP DR BETWEEN 49TH AND DASSCO ST
CORNER OF BROADWAY & 65TH
6353 Broadway
927 63rd St
6373 BROADWAY
819 65TH ST
65TH ST & WUNDERLJN AVE
822 65TH ST



6581 BROADWAY
6501 BROADWAY
65TH ST & WUNDERLIN AVE
A/F 4588 MARKET ST
A/F 4588 MARKET ST
A/F 4588 MARKET ST
A/F 4588 MARKET ST
A/F 4588 MARKET ST
A/F 4538 MARKET ST
A/F 6744 AKINSAVE ON IMPERIAL AVE (ENCANTO PARK)
INTERSECTION OF WOODMAN ST AND IMPERIAL AV
4704 Imperial Av
4704 Imperial Av (On Escuela St)
4758 IMPERIAL AV
160 61st ST
201 LAUSANNE DR
228 MIDDLEBUSH DR
311 SAWTELLE AV
305 Encinitas Av
BETWEEN SAWTELLE AV AND SUNNYSIDE AV
BETWEEN SAWTELLE AV AND SUNNYSIDE AV
BETWEEN ENCINITAS AV AND SUNNYSIDE AV
BETWEEN ENCINITAS AV AND SUNNYSIDE AV
A/F 135 S47TH ST
4801 Ocean View BL (John F. Kennedy Park)
4801 Ocean View BL (at Cul-de-sac)
4801 OCEAN VIEW BL (END OF CUL-DE-SAC)
4801 OCEAN VIEW BL (END OF CUL-DE-SAC)
A/F 135 S47TH ST
4910 Imperial Av
4891 OCEAN VIEW BL
A/F 5821 SKYLINE DR
6081 Flipper DR
A/F 5941 SKYLINE DR
A/F 5959 SKYLINE DR
6040 SKYLINE DR
6081 FLIPPER DR
6045 FLIPPER DR
300 S61ST ST (SOUTH OF TICKNOR CT)
300 S61ST ST (BETWEEN TICKNOR CT & TEMPAS CT)
300 S61ST ST (BETWEEN FLIPPER DR & TEMPAS CT)
150 61ST ST
6050 Skyline DR
6905 SKYLINE DR
A/F 7052 Skyline DR
A/F 7092 SKYLINE DR
A/F 7092 SKYLINE DR

A/F 7062 SKYLINE DR
A/F 7042 SKYLINE DR
A/F 7032 SKYLINE DR
A/F 7022 SKYLINE DR
A/F 6799 CIELO DR
6905 SKYLINE DR (@ TIMELY TERRACE ST)
105 TIMELY TR
A/F 172 BUCCANEER DR
100 SLAUSANNE DR (BETWEEN SKYLINE & PETER PAN AVE)
7534 WOODBINE WY
8033 SKYLINE DR
8049 SKYLINE DR
271 FLOWERDALE LN
8140 GREENLAWN DR
530 S 47TH ST
4800 T ST
4715 T ST
650 GLORIA ST (GLORIA ST & T ST)
4802 T ST
4850 BUNNELL ST
6360 PITTSBURGH AV (@ MORAEA ST)
6370 VARNEY DR
333 CORALWOOD DR
7849 BROOKHAVEN RD
A/F 1886 PARKLAND WY
1948 PARKLAND WY
6844 BENJAMIN HOLT RD
6832 PARADISE VALLEY RD (W OF S WOODMAN ST)
1120 S WOODMAN ST
1915 PARKLAND WY
6801 PARADISE VALLEY RD (NE OF POTOMIC ST)
6801 PARADISE VALLEY RD (NE OF POTOMIC ST)
6801 PARADISE VALLEY RD (NE OF POTOMIC ST)
6849 PARADISE VALLEY RD (SW OF S WOODMAN ST)
6849 PARADISE VALLEY RD (SW OF S WOODMAN ST)
A/F 7316 NEBRASKA AV
1953 ORISKANY RD
1953 ORISKANY RD
1985 ORISKANY RD
1954 ORISKANY RD
1901 MUNDA RD
1540 RIDGEWOOD DR
1844 ALTA VIEW DR
1824 ALTA VIEW DR
1863 ALTA VIEW DR
1855 ALTA VIEW DR
5793 ALTAMOUNT DR (ON REO DR)

5905 ALLEGHANY ST
5941 ALLEGHANY ST
5821 ALLEGHANY ST
5873 Alleghany St
A/F 5821 ALLEGHANY ST
A/F 5859 ALLEGHANY ST
A/F 2245 CALLE SERENA
A/F 2626 DUSK DR
2620 DUSK DR
2614 DUSK DR
2608 DUSK DR
A/F 2556 DUSK DR
2500 DUSK DR (@HYMAN FL)
2500 DUSK DR (@HYMAN FL)
2500 DUSK DR (@KEEN DR)
2500 DUSK DR (@HYMAN FL)
6523 HYMAN FL
6532 HYMAN FL
2586 DUSK DR
2905 ALTA VIEW DR (ON SWOODMAN ST)
2905 ALTA VIEW DR (ON SWOODMAN ST)
7055 PARKSIDE AV
A/F 6815 RAMFOSCR
6042 RANCHO HILLS DR
6120 RANCHO HILLS DR
6164 RANCHO HILLS DR
A/F 6144 RANCHO HILLS DR
6184 RANCHO HILLS DR
2752 Dusk Dr
A/F 2686 DUSK DR
A/F 2664 DUSK DR
A/F 2638 DUSK DR
2650 Dusk Dr
2710 Dusk Dr
2720 Dusk Dr
2752 DUSK DR
3049 MT MIGUEL DR
2262 ISLAND AV
404 22ND ST
409 27TH ST
A/F 458 26th St
425 27TH ST
441 27TH ST
A/F 446 26TH ST
A/F 2663 JST
A/F 2605 JST
446 26TH ST

A/F 2585 JST
2445 IMPERIAL AV
2589 IMPERIAL AV
2710 IMPERIAL AV
2629 JST
2695 JST
331 27TH ST
351 27TH ST
2704 K ST
2704 K ST
3050 IMPERIAL AV
3018 IMPERIAL AV
3040 L ST
2866 IMPERIAL AV
2874 IMPERIAL AV
A/F 321 DODSON ST
A/F 355 DODSON ST
A/F 355 DODSON ST
1775 NATIONAL AV
A/F 113 West Park Av
2430 Commercial St
2840 Ocean View BL
717 S30TH ST
849 S29th St
714 S 28th St
2850 Logan Ave
711 S30TH ST
800 S30TH ST (@ GREELY AVE)
A/F 850 S30TH ST
A/F 719 S30TH ST
A/F 639 S30TH ST
A/F 505 S30TH ST
A/F 614 S28TH ST
A/F 2634 IRVING AVE (ON 600 S28TH ST)
3093 MARTIN AV
A/F 730 S31ST ST
A/F 730 S31ST ST
2914 NATIONAL AV
3015 LEILANI WY (ON PALM (SB) AV)
2935 LEILANI WY (ON PALM (SB) AV)
2905 Leilani Way ( On Palm Av)
3039 Palm Av
2955 LEILANI WY (ON PALM (SB) AV)
2905 PALM (SB) AV & BEYER BLVD
2905 PALM (SB) AV & BEYER BLVD
3052 PALM (SB) AV
3052 PALM (SB) AV

3240 Palm Av

3060 PALM (SB) AV (ON HAWAII AV)
3100 PALM (SB) AV
3240 PALM (SB) AV
3240 PALM (SB) AV
3295 PALM (SB) AV
3295 PALM (SB) AV
2995 PALM (SB) AV
3039 PALM (SB) AV
900 Saturn BL (at Eder Ave)
910 SATURN BL
3752 AREY DR
A/F 3892 AREY DR
907 TWINING AV (BETWEEN DEBBYANN PL & AREY DR)
849 Twining Ave
829 TWINING AV
A/F 877 TWINING AV
1731 CORONADO (SB) AV (BETWEEN 19TH & 17TH)
1131 SATURN BL (SCORONADO AVE)
1128 Saturn BL
A/F 1215 SATURN BL
A/F 1061 19TH ST
A/F 1061 19TH ST
1051 PICADOR BL
976 PICADOR BL
1150 PICADOR BL
A/F 3723 ANDREWSCT
A/F 3743 ANDREWSCT
A/F 3743 ANDREWSCT
1500 TRITON PL
A/F 1430 27TH (SB) ST
A/F 1460 27TH (SB) ST
3005 TEQUILA WY
3133 PLANTEL WY
1701 SMYTHE AV
1701 SMYTHE AV
1701 SMYTHE AV
1770 SMYTHE AV
1770 SMYTHE AV
1839 CAM DE LASSONRISAS
256 AVNDA DE LA MADRID
221 AVNDA DE LA MADRID
3852 SUNSET LN
A/F 141 ALVERSON RD
A/F 139 ALVERSON RD
A/F 139 ALVERSON RD
134 EAST PARK AV

A/F 221 West Park Av

211 West Park Ave

158 EAST PARK AV
244 EAST PARK AV
268 EAST PARK AVE (ON SEAWARD AV)
A/F 147 WEST PARK AV
127 WEST PARK AV
A/F 279 WEST PARK AV
217 WEST PARK AV
A/F 110 EAST PARK AV
4200 CAM DE LA PLAZA
640 E SAN YSIDRO BL
5005 LA DORNA ST

4588 Euclid Ave

4562 EUCLID AV
4534 ARAGON DR
6459 MALCOLM DR
4196 44TH ST
4247 54TH PL

2367 & 2361 Trojan

5373 TROJAN AV
5361 TROJAN AV
3519 WIGHTMAN ST
3717 UNIVERSITY AV
4538 UNIVERSITY AV

4526 UNIVERSITY AVE

4034 45TH ST
3585 CENTRAL AV
3429 41ST ST
4184 & 4188 MANZANITA DR

4278 Poplar St

4282 Poplar

4273 POPLAR ST
4444 REDWOOD ST
4721 WENDELL ST

2712 Wendell St

2238 Ridge View Dr

2231 Ridge View Dr

2258 RIDGE VIEW DR
--------------------

789 Gateway Center Way

A/F 887 BOUNDARY ST
---------------------

A/F 859 Boundary St

A/F 875 BOUNDARY ST
---------------------

A/F 859 BOUNDARY ST
---------------------

825 42nd St

836 42nd St

858 42ND ST
-------------

A/F 819 BOUNDARY ST
628 Raven St
622 Raven St
610 Gateway Center Way
A/F 819 BOUNDARY ST
A/F 819 BOUNDARY ST
A/F 629 BOUNDARY ST
610 GATEWAY CENTER WY
610 GATEWAY CENTER WY (@MARKET ST)
789 GATEWAY CENTER WY
704 RAVEN ST
709 S36TH ST
827 S36TH ST
S35TH & FLORENCE ST
851 S35TH ST
851 S35TH ST
705 S35TH ST
701 S35TH ST
3976 FLORENCE ST
3994 FLORENCE ST
3994 FLORENCE ST (@END OF CAL-DE-SJC)
3991 FLORENCE ST
598 S40TH ST
841 S41st St
795 S41ST ST
3571 BOSTON AV
A/F 3550 Logan Ave
3742 NATIONAL AVE
1221 S35TH ST
A/F 3521 BOSTON AV
A/F 3551 BOSTON AV
A/F 3557 BOSTON AV
A/F 1025 S35TH ST
3550 LOGAN AV
3744 NATIONAL AV
3744 NATIONAL AV
827 S36TH ST
1071 South 41st St
A/F 4178 NEWTON AV
1051 S45TH ST
1051 S45TH ST
1051 S45TH ST
1224 S45TH ST
4658 Orange Av
A/F 4118 Menlo Av
A/F 4136 Menlo Av
A/F 4115 Euclid Av

Polk & Euclid (on Euclid Av, NorthWest side)  
Polk & Euclid (on Euclid Av, NorthEast side)  
A/F 5500 Aztec Walk (SDSU Lot 2A)  
College Ave & SDSU Campus Parking  
College Ave & SDSU Campus Parking (350 ft N SDSU Campus Parking)  
4860 Catoctin Dr  
4860 Catoctin Dr  
A/F 4959 Catoctin Dr  
A/F 4490 Highland Av  
4252 37th St  
A/F 3762 EL Cajon BL  
4263 39th St  
4259 39th St  
4251 39th St  
4241 39th St  
3773 EL Cajon BL  
4396 Highland Ave  
4387 46th St  
A/F 4416 Highland Ave  
A/F 4048 35th St  
A/F 4028 35th St  
4022 35th St  
4026 36th St  
A/F 4065 Wilson Ave  
3471 Polk Ave  
4096 35th St (On Polk Ave)  
3353 Polk Ave  
3677 Orange Ave  
3676 Orange Ave  
Orange Ave and 37th St  
4222 37th St  
3700 Orange Ave ( Orange & 37th)  
3700 Orange Ave ( Orange & 37th)  
A/F 3737 Orange Ave  
3695 37th St  
4178 37th St  
A/F 4215 39th St. (School Entrance)  
4233 39th St  
4215/4219 39th St  
3901 Orange Ave  
A/F 4667 Polk Ave  
A/F 4667 Polk Ave  
4115 Euclid Ave  
4145 Euclid Ave  
A/F 4127 Euclid Ave  
3711 Chamoune Ave  
A/F 4528 Wightman St



**APPENDIX B**  
**FIRE HYDRANT METER PROGRAM**

<b>CITY OF SAN DIEGO CALIFORNIA DEPARTMENT INSTRUCTIONS</b>	<b>NUMBER DI 55.27</b>	<b>DEPARTMENT Water Department</b>
<b>SUBJECT  FIRE HYDRANT METER PROGRAM (FORMERLY: CONSTRUCTION METER PROGRAM)</b>	<b>PAGE 1 OF 10</b>	<b>EFFECTIVE DATE  October 15, 2002</b>
	<b>SUPERSEDES DI 55.27</b>	<b>DATED April 21, 2000</b>

1. **PURPOSE**

- 1.1 To establish a Departmental policy and procedure for issuance, proper usage and charges for fire hydrant meters.

2. **AUTHORITY**

- 2.1 All authorities and references shall be current versions and revisions.
- 2.2 San Diego Municipal Code (NC) Chapter VI, Article 7, Sections 67.14 and 67.15
- 2.3 Code of Federal Regulations, Safe Drinking Water Act of 1986
- 2.4 California Code of Regulations, Titles 17 and 22
- 2.5 California State Penal Code, Section 498B.0
- 2.6 State of California Water Code, Section 110, 500-6, and 520-23
- 2.7 Water Department Director

**Reference**

- 2.8 State of California Guidance Manual for Cross Connection Programs
- 2.9 American Water Works Association Manual M-14, Recommended Practice for Backflow Prevention
- 2.10 American Water Works Association Standards for Water Meters
- 2.11 U.S.C. Foundation for Cross Connection Control and Hydraulic Research Manual

3. **DEFINITIONS**

- 3.1 **Fire Hydrant Meter:** A portable water meter which is connected to a fire hydrant for the purpose of temporary use. (These meters are sometimes referred to as Construction Meters.)

<b>CITY OF SAN DIEGO CALIFORNIA DEPARTMENT INSTRUCTIONS</b>	<b>NUMBER DI 55.27</b>	<b>DEPARTMENT Water Department</b>
<b>SUBJECT  FIRE HYDRANT METER PROGRAM (FORMERLY: CONSTRUCTION METER PROGRAM)</b>	<b>PAGE 2 OF 10</b>	<b>EFFECTIVE DATE  October 15, 2002</b>
	<b>SUPERSEDES DI 55.27</b>	<b>DATED April 21, 2000</b>

- 3.2 **Temporary Water Use:** Water provided to the customer for no longer than twelve (12) months.
- 3.3 **Backflow Preventor:** A Reduced Pressure Principal Assembly connected to the outlet side of a Fire Hydrant Meter.

4. **POLICY**

- 4.1 The Water Department shall collect a deposit from every customer requiring a fire hydrant meter and appurtenances prior to providing the meter and appurtenances (see Section 7.1 regarding the Fees and Deposit Schedule). The deposit is refundable upon the termination of use and return of equipment and appurtenances in good working condition.
- 4.2 Fire hydrant meters will have a 2 ½" swivel connection between the meter and fire hydrant. The meter shall not be connected to the 4" port on the hydrant. All Fire Hydrant Meters issued shall have a Reduced Pressure Principle Assembly (RP) as part of the installation. Spanner wrenches are the only tool allowed to turn on water at the fire hydrant.
- 4.3 The use of private hydrant meters on City hydrants is prohibited, with exceptions as noted below. All private fire hydrant meters are to be phased out of the City of San Diego. All customers who wish to continue to use their own fire hydrant meters must adhere to the following conditions:
  - a. Meters shall meet all City specifications and American Water Works Association (AWWA) standards.
  - b. Customers currently using private fire hydrant meters in the City of San Diego water system will be allowed to continue using the meter under the following conditions:
    - 1. The customer must submit a current certificate of accuracy and calibration results for private meters and private backflows annually to the City of San Diego, Water Department, Meter Shop.

<b>CITY OF SAN DIEGO CALIFORNIA DEPARTMENT INSTRUCTIONS</b>	<b>NUMBER DI 55.27</b>	<b>DEPARTMENT Water Department</b>
<b>SUBJECT  FIRE HYDRANT METER PROGRAM (FORMERLY: CONSTRUCTION METER PROGRAM)</b>	<b>PAGE 3 OF 10</b>	<b>EFFECTIVE DATE  October 15, 2002</b>
	<b>SUPERSEDES DI 55.27</b>	<b>DATED April 21, 2000</b>

2. The meter must be properly identifiable with a clearly labeled serial number on the body of the fire hydrant meter. The serial number shall be plainly stamped on the register lid and the main casing. Serial numbers shall be visible from the top of the meter casing and the numbers shall be stamped on the top of the inlet casing flange.
3. All meters shall be locked to the fire hydrant by the Water Department, Meter Section (see Section 4.7).
4. All meters shall be read by the Water Department, Meter Section (see Section 4.7).
5. All meters shall be relocated by the Water Department, Meter Section (see Section 4.7).
6. These meters shall be tested on the anniversary of the original test date and proof of testing will be submitted to the Water Department, Meter Shop, on a yearly basis. If not tested, the meter will not be allowed for use in the City of San Diego.
7. All private fire hydrant meters shall have backflow devices attached when installed.
8. The customer must maintain and repair their own private meters and private backflows.
9. The customer must provide current test and calibration results to the Water Department, Meter Shop after any repairs.
10. When private meters are damaged beyond repair, these private meters will be replaced by City owned fire hydrant meters.

<b>CITY OF SAN DIEGO CALIFORNIA DEPARTMENT INSTRUCTIONS</b>	<b>NUMBER DI 55.27</b>	<b>DEPARTMENT Water Department</b>
<b>SUBJECT  FIRE HYDRANT METER PROGRAM (FORMERLY: CONSTRUCTION METER PROGRAM)</b>	<b>PAGE 4 OF 10</b>	<b>EFFECTIVE DATE  October 15, 2002</b>
	<b>SUPERSEDES DI 55.27</b>	<b>DATED April 21, 2000</b>

11. When a private meter malfunctions, the customer will be notified and the meter will be removed by the City and returned to the customer for repairs. Testing and calibration results shall be given to the City prior to any re-installation.
  12. The register shall be hermetically sealed straight reading and shall be readable from the inlet side. Registration shall be in hundred cubic feet.
  13. The outlet shall have a 2 ½ “National Standards Tested (NST) fire hydrant male coupling.
  14. Private fire hydrant meters shall not be transferable from one contracting company to another (i.e. if a company goes out of business or is bought out by another company).
- 4.4 All fire hydrant meters and appurtenances shall be installed, relocated and removed by the City of San Diego, Water Department. All City owned fire hydrant meters and appurtenances shall be maintained by the City of San Diego, Water Department, Meter Services.
- 4.5 If any fire hydrant meter is used in violation of this Department Instruction, the violation will be reported to the Code Compliance Section for investigation and appropriate action. Any customer using a fire hydrant meter in violation of the requirements set forth above is subject to fines or penalties pursuant to the Municipal Code, Section 67.15 and Section 67.37.
- 4.6 **Conditions and Processes for Issuance of a Fire Hydrant Meter**
- Process for Issuance
- a. Fire hydrant meters shall only be used for the following purposes:
    1. Temporary irrigation purposes not to exceed one year.

<b>CITY OF SAN DIEGO CALIFORNIA DEPARTMENT INSTRUCTIONS</b>	<b>NUMBER DI 55.27</b>	<b>DEPARTMENT Water Department</b>
<b>SUBJECT  FIRE HYDRANT METER PROGRAM (FORMERLY: CONSTRUCTION METER PROGRAM)</b>	<b>PAGE 5 OF 10</b>	<b>EFFECTIVE DATE  October 15, 2002</b>
	<b>SUPERSEDES DI 55.27</b>	<b>DATED April 21, 2000</b>

2. Construction and maintenance related activities (see Tab 2).
  - b. No customer inside or outside the boundaries of the City of San Diego Water Department shall resell any portion of the water delivered through a fire hydrant by the City of San Diego Water Department.
  - c. The City of San Diego allows for the issuance of a temporary fire hydrant meter for a period not to exceed 12 months (365 days). An extension can only be granted in writing from the Water Department Director for up to 90 additional days. A written request for an extension by the consumer must be submitted at least 30 days prior to the 12 month period ending. No extension shall be granted to any customer with a delinquent account with the Water Department. No further extensions shall be granted.
  - d. Any customer requesting the issuance of a fire hydrant meter shall file an application with the Meter Section. The customer must complete a "Fire Hydrant Meter Application" (Tab 1) which includes the name of the company, the party responsible for payment, Social Security number and/or California ID, requested location of the meter (a detailed map signifying an exact location), local contact person, local phone number, a contractor's license (or a business license), description of specific water use, duration of use at the site and full name and address of the person responsible for payment.
  - e. At the time of the application the customer will pay their fees according to the schedule set forth in the Rate Book of Fees and Charges, located in the City Clerk's Office. All fees must be paid by check, money order or cashiers check, made payable to the City Treasurer. Cash will not be accepted.
  - f. No fire hydrant meters shall be furnished or relocated for any customer with a delinquent account with the Water Department.
  - g. After the fees have been paid and an account has been created, the

<b>CITY OF SAN DIEGO CALIFORNIA DEPARTMENT INSTRUCTIONS</b>	<b>NUMBER DI 55.27</b>	<b>DEPARTMENT Water Department</b>
<b>SUBJECT  FIRE HYDRANT METER PROGRAM (FORMERLY: CONSTRUCTION METER PROGRAM)</b>	<b>PAGE 6 OF 10</b>	<b>EFFECTIVE DATE  October 15, 2002</b>
	<b>SUPERSEDES DI 55.27</b>	<b>DATED April 21, 2000</b>

meter shall be installed within 48 hours (by the second business day). For an additional fee, at overtime rates, meters can be installed within 24 hours (within one business day).

#### 4.7 Relocation of Existing Fire Hydrant Meters

- a. The customer shall call the Fire Hydrant Meter Hotline (herein referred to as "Hotline"), a minimum of 24 hours in advance, to request the relocation of a meter. A fee will be charged to the existing account, which must be current before a work order is generated for the meter's relocation.
- b. The customer will supply in writing the address where the meter is to be relocated (map page, cross street, etc). The customer must update the original Fire Hydrant Meter Application with any changes as it applies to the new location.
- c. Fire hydrant meters shall be read on a monthly basis. While fire hydrant meters and backflow devices are in service, commodity, base fee and damage charges, if applicable, will be billed to the customer on a monthly basis. If the account becomes delinquent, the meter will be removed.

#### 4.8 Disconnection of Fire Hydrant Meter

- a. After ten (10) months a "Notice of Discontinuation of Service" (Tab 3) will be issued to the site and the address of record to notify the customer of the date of discontinuance of service. An extension can only be granted in writing from the Water Department Director for up to 90 additional days (as stated in Section 4.6C) and a copy of the extension shall be forwarded to the Meter Shop Supervisor. If an extension has not been approved, the meter will be removed after twelve (12) months of use.
- b. Upon completion of the project the customer will notify the Meter Services office via the Hotline to request the removal of the fire hydrant meter and appurtenances. A work order will be generated

<b>CITY OF SAN DIEGO CALIFORNIA DEPARTMENT INSTRUCTIONS</b>	<b>NUMBER DI 55.27</b>	<b>DEPARTMENT Water Department</b>
<b>SUBJECT  FIRE HYDRANT METER PROGRAM (FORMERLY: CONSTRUCTION METER PROGRAM)</b>	<b>PAGE 7 OF 10</b>	<b>EFFECTIVE DATE  October 15, 2002</b>
	<b>SUPERSEDES DI 55.27</b>	<b>DATED April 21, 2000</b>

for removal of the meter.

- c. Meter Section staff will remove the meter and backflow prevention assembly and return it to the Meter Shop. Once returned to the Meter Shop the meter and backflow will be tested for accuracy and functionality.
- d. Meter Section Staff will contact and notify Customer Services of the final read and any charges resulting from damages to the meter and backflow or its appurtenance. These charges will be added on the customer's final bill and will be sent to the address of record. Any customer who has an outstanding balance will not receive additional meters.
- e. Outstanding balances due may be deducted from deposits and any balances refunded to the customer. Any outstanding balances will be turned over to the City Treasurer for collection. Outstanding balances may also be transferred to any other existing accounts.

5. **EXCEPTIONS**

- 5.1 Any request for exceptions to this policy shall be presented, in writing, to the Customer Support Deputy Director, or his/her designee for consideration.

6. **MOBILE METER**

- 6.1 Mobile meters will be allowed on a case by case basis. All mobile meters will be protected by an approved backflow assembly and the minimum requirement will be a Reduced Pressure Principal Assembly. The two types of Mobile Meters are vehicle mounted and floating meters. Each style of meters has separate guidelines that shall be followed for the customer to retain service and are described below:

- a) **Vehicle Mounted Meters:** Customer applies for and receives a City owned Fire Hydrant Meter from the Meter Shop. The customer mounts the meter on the vehicle and brings it to the Meter Shop for



<b>CITY OF SAN DIEGO CALIFORNIA DEPARTMENT INSTRUCTIONS</b>	<b>NUMBER DI 55.27</b>	<b>DEPARTMENT Water Department</b>
<b>SUBJECT  FIRE HYDRANT METER PROGRAM (FORMERLY: CONSTRUCTION METER PROGRAM)</b>	<b>PAGE 8 OF 10</b>	<b>EFFECTIVE DATE  October 15, 2002</b>
	<b>SUPERSEDES DI 55.27</b>	<b>DATED April 21, 2000</b>

inspection. After installation is approved by the Meter Shop the vehicle and meter shall be brought to the Meter Shop on a monthly basis for meter reading and on a quarterly basis for testing of the backflow assembly. Meters mounted at the owner's expense shall have the one year contract expiration waived and shall have meter or backflow changed if either fails.

b) **Floating Meters:** Floating Meters are meters that are not mounted to a vehicle. **(Note: All floating meters shall have an approved backflow assembly attached.)** The customer shall submit an application and a letter explaining the need for a floating meter to the Meter Shop. The Fire Hydrant Meter Administrator, after a thorough review of the needs of the customer, (i.e. number of jobsites per day, City contract work, lack of mounting area on work vehicle, etc.), may issue a floating meter. At the time of issue, it will be necessary for the customer to complete and sign the "Floating Fire Hydrant Meter Agreement" which states the following:

- 1) The meter will be brought to the Meter Shop at 2797 Caminito Chollas, San Diego on the third week of each month for the monthly read by Meter Shop personnel.
- 2) Every other month the meter will be read and the backflow will be tested. This date will be determined by the start date of the agreement.

If any of the conditions stated above are not met the Meter Shop has the right to cancel the contract for floating meter use and close the account associated with the meter. The Meter Shop will also exercise the right to refuse the issuance of another floating meter to the company in question.

Any Fire Hydrant Meter using reclaimed water shall not be allowed use again with any potable water supply. The customer shall incur the cost of replacing the meter and backflow device in this instance.

<b>CITY OF SAN DIEGO CALIFORNIA DEPARTMENT INSTRUCTIONS</b>	<b>NUMBER DI 55.27</b>	<b>DEPARTMENT Water Department</b>
<b>SUBJECT  FIRE HYDRANT METER PROGRAM (FORMERLY: CONSTRUCTION METER PROGRAM)</b>	<b>PAGE 9 OF 10</b>	<b>EFFECTIVE DATE  October 15, 2002</b>
	<b>SUPERSEDES DI 55.27</b>	<b>DATED April 21, 2000</b>

**7. FEE AND DEPOSIT SCHEDULES**

7.1 **Fees and Deposit Schedules:** The fees and deposits, as listed in the Rate Book of Fees and Charges, on file with the Office of the City Clerk, are based on actual reimbursement of costs of services performed, equipment and materials. These deposits and fees will be amended, as needed, based on actual costs. Deposits, will be refunded at the end of the use of the fire hydrant meter, upon return of equipment in good working condition and all outstanding balances on account are paid. Deposits can also be used to cover outstanding balances.

All fees for equipment, installation, testing, relocation and other costs related to this program are subject to change without prior notification. The Mayor and Council will be notified of any future changes.

**8. UNAUTHORIZED USE OF WATER FROM A HYDRANT**

8.1 Use of water from any fire hydrant without a properly issued and installed fire hydrant meter is theft of City property. Customers who use water for unauthorized purposes or without a City of San Diego issued meter will be prosecuted.

8.2 If any unauthorized connection, disconnection or relocation of a fire hydrant meter, or other connection device is made by anyone other than authorized Water Department personnel, the person making the connection will be prosecuted for a violation of San Diego Municipal Code, Section 67.15. In the case of a second offense, the customer's fire hydrant meter shall be confiscated and/or the deposit will be forfeited.

8.3 Unauthorized water use shall be billed to the responsible party. Water use charges shall be based on meter readings, or estimates when meter readings are not available.

8.4 In case of unauthorized water use, the customer shall be billed for all applicable charges as if proper authorization for the water use had been obtained, including but not limited to bi-monthly service charges, installation charges and removal charges.

<b>CITY OF SAN DIEGO CALIFORNIA DEPARTMENT INSTRUCTIONS</b>	<b>NUMBER DI 55.27</b>	<b>DEPARTMENT Water Department</b>
<b>SUBJECT  FIRE HYDRANT METER PROGRAM (FORMERLY: CONSTRUCTION METER PROGRAM)</b>	<b>PAGE 10 OF 10</b>	<b>EFFECTIVE DATE  October 15, 2002</b>
	<b>SUPERSEDES DI 55.27</b>	<b>DATED April 21, 2000</b>

- 8.5 If damage occurs to Water Department property (i.e. fire hydrant meter, backflow, various appurtenances), the cost of repairs or replacements will be charged to the customer of record (applicant).

**Larry Gardner  
Water Department Director**

- Tabs: 1. Fire Hydrant Meter Application  
2. Construction & Maintenance Related Activities With No Return To Sewer  
3. Notice of Discontinuation of Service

#### **APPENDIX**

**Administering Division:** Customer Support Division

**Subject Index:** Construction Meters  
Fire Hydrant  
Fire Hydrant Meter Program  
Meters, Floating or Vehicle Mounted  
Mobile Meter  
Program, Fire Hydrant Meter

**Distribution:** DI Manual Holders



# Application for Fire Hydrant Meter (EXHIBIT A)

(For Office Use Only)

NS REQ	FAC#
DATE	BY

METER SHOP (619) 527-7449

## Meter Information

Application Date	Requested Install Date:
------------------	-------------------------

Fire Hydrant Location: (Attach Detailed Map//Thomas Bros. Map Location or Construction drawing.) Zip:	T.B.	G.B. (CITY USE)
Specific Use of Water:		
Any Return to Sewer or Storm Drain, if so, explain:		
Estimated Duration of Meter Use:	<input type="checkbox"/>	<input type="checkbox"/> Check Box if Reclaimed Water

## Company Information

Company Name:			
Mailing Address:			
City:	State:	Zip:	Phone: ( )
*Business license#		*Contractor license#	
A Copy of the Contractor's license OR Business License is required at the time of meter issuance.			
Name and Title of Billing Agent: <small>(PERSON IN ACCOUNTS PAYABLE)</small>			Phone: ( )
Site Contact Name and Title:			Phone: ( )
Responsible Party Name:			Title:
Cal ID#			Phone: ( )
Signature:		Date:	
Guarantees Payment of all Charges Resulting from the use of this Meter. Insures that employees of this Organization understand the proper use of Fire Hydrant Meter			

Fire Hydrant Meter Removal Request	Requested Removal Date:
Provide Current Meter Location if Different from Above:	
Signature:	Title: Date:
Phone: ( )	Pager: ( )

City Meter	Private Meter
Contract Acct #:	Deposit Amount: <b>\$ 936.00</b> Fees Amount: <b>\$ 62.00</b>
Meter Serial #	Meter Size: <b>05</b> Meter Make and Style: <b>6-7</b>
Backflow #	Backflow Size: Backflow Make and Style:
Name:	Signature: Date:

WATER USES WITHOUT ANTICIPATED CHARGES FOR RETURN TO SEWER

Auto Detailing  
Backfilling  
Combination Cleaners (Vactors)  
Compaction  
Concrete Cutters  
Construction Trailers  
Cross Connection Testing  
Dust Control  
Flushing Water Mains  
Hydro Blasting  
Hydro Seeing  
Irrigation (for establishing irrigation only; not continuing irrigation)  
Mixing Concrete  
Mobile Car Washing  
Special Events  
Street Sweeping  
Water Tanks  
Water Trucks  
Window Washing

**Note:**

1. If there is any return to sewer or storm drain, then sewer and/or storm drain fees will be charges.

Date

Name of Responsible Party  
Company Name and Address  
Account Number: \_\_\_\_\_

Subject: Discontinuation of Fire Hydrant Meter Service

Dear Water Department Customer:

The authorization for use of Fire Hydrant Meter # \_\_\_\_\_, located at (*Meter Location Address*) ends in 60 days and will be removed on or after (*Date Authorization Expires*). Extension requests for an additional 90 days must be submitted in writing for consideration 30 days prior to the discontinuation date. If you require an extension, please contact the Water Department, or mail your request for an extension to:

City of San Diego  
Water Department  
Attention: Meter Services  
2797 Caminito Chollas  
San Diego, CA 92105-5097

Should you have any questions regarding this matter, please call the Fire Hydrant Hotline at (619) \_\_\_\_\_ - \_\_\_\_\_.

Sincerely,

Water Department

**APPENDIX C**

**MATERIALS TYPICALLY ACCEPTED BY CERTIFICATE OF COMPLIANCE**

### Materials Typically Accepted by Certificate of Compliance

1. Soil amendment
2. Fiber mulch
3. PVC or PE pipe up to 16 inch diameter
4. Stabilizing emulsion
5. Lime
6. Preformed elastomeric joint seal
7. Plain and fabric reinforced elastomeric bearing pads
8. Steel reinforced elastomeric bearing pads
9. Waterstops (Special Condition)
10. Epoxy coated bar reinforcement
11. Plain and reinforcing steel
12. Structural steel
13. Structural timber and lumber
14. Treated timber and lumber
15. Lumber and timber
16. Aluminum pipe and aluminum pipe arch
17. Corrugated steel pipe and corrugated steel pipe arch
18. Structural metal plate pipe arches and pipe arches
19. Perforated steel pipe
20. Aluminum underdrain pipe
21. Aluminum or steel entrance tapers, pipe downdrains, reducers, coupling bands and slip joints
22. Metal target plates
23. Paint (traffic striping)
24. Conductors
25. Painting of electrical equipment
26. Electrical components
27. Engineering fabric
28. Portland Cement
29. PCC admixtures
30. Minor concrete, asphalt
31. Asphalt (oil)
32. Liquid asphalt emulsion
33. Epoxy



**APPENDIX D**  
**SAMPLE CITY INVOICE**



**APPENDIX E**  
**LOCATION MAPS**

# Sidewalk Replacement Group 1601

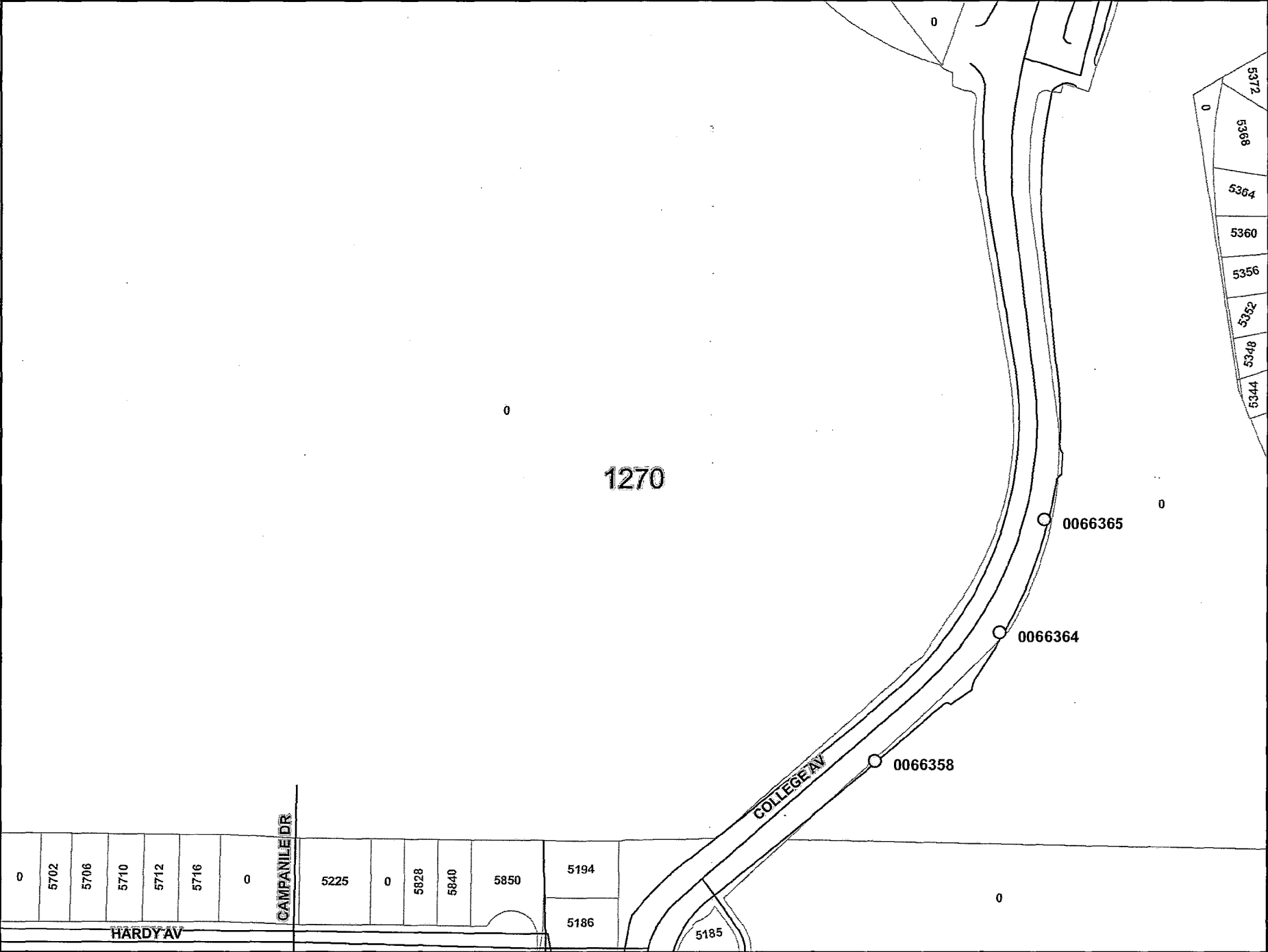

# Sidewalk Replacement Group 1601 Index Map

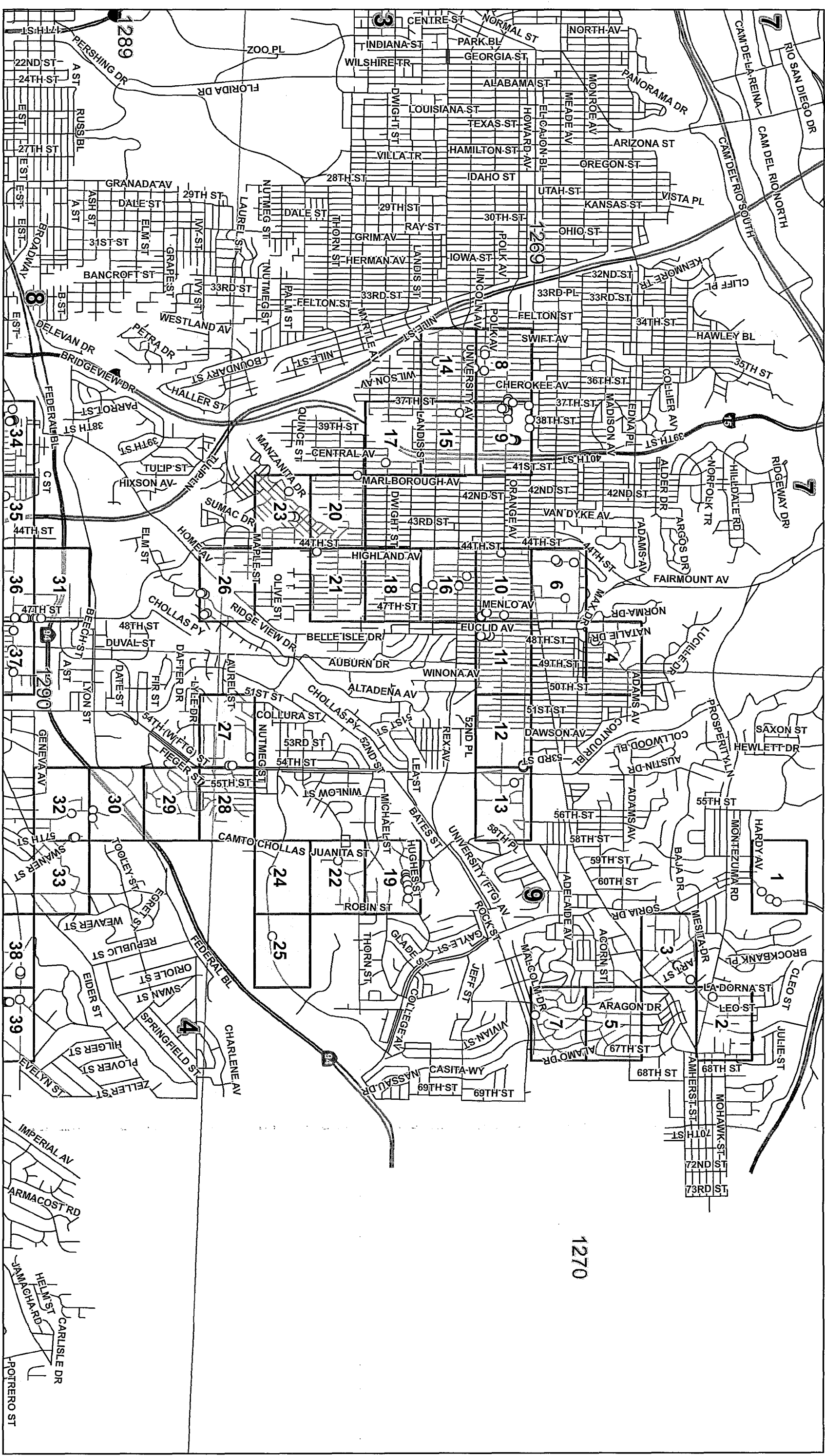

11x17

# Sidewalk Replacement Group 1601 Index Map

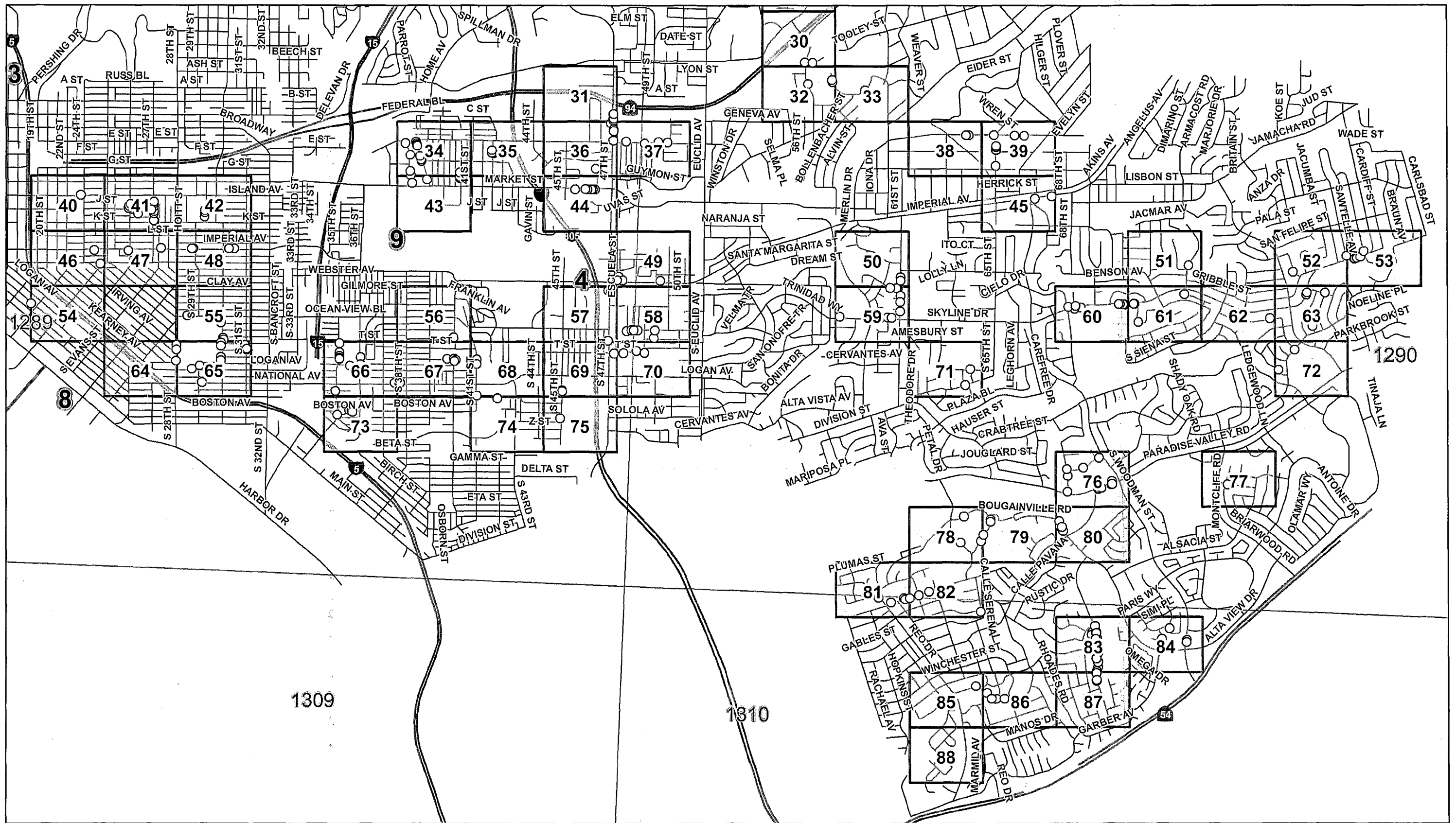

# Sidewalk Replacement Group 1601 Index Map

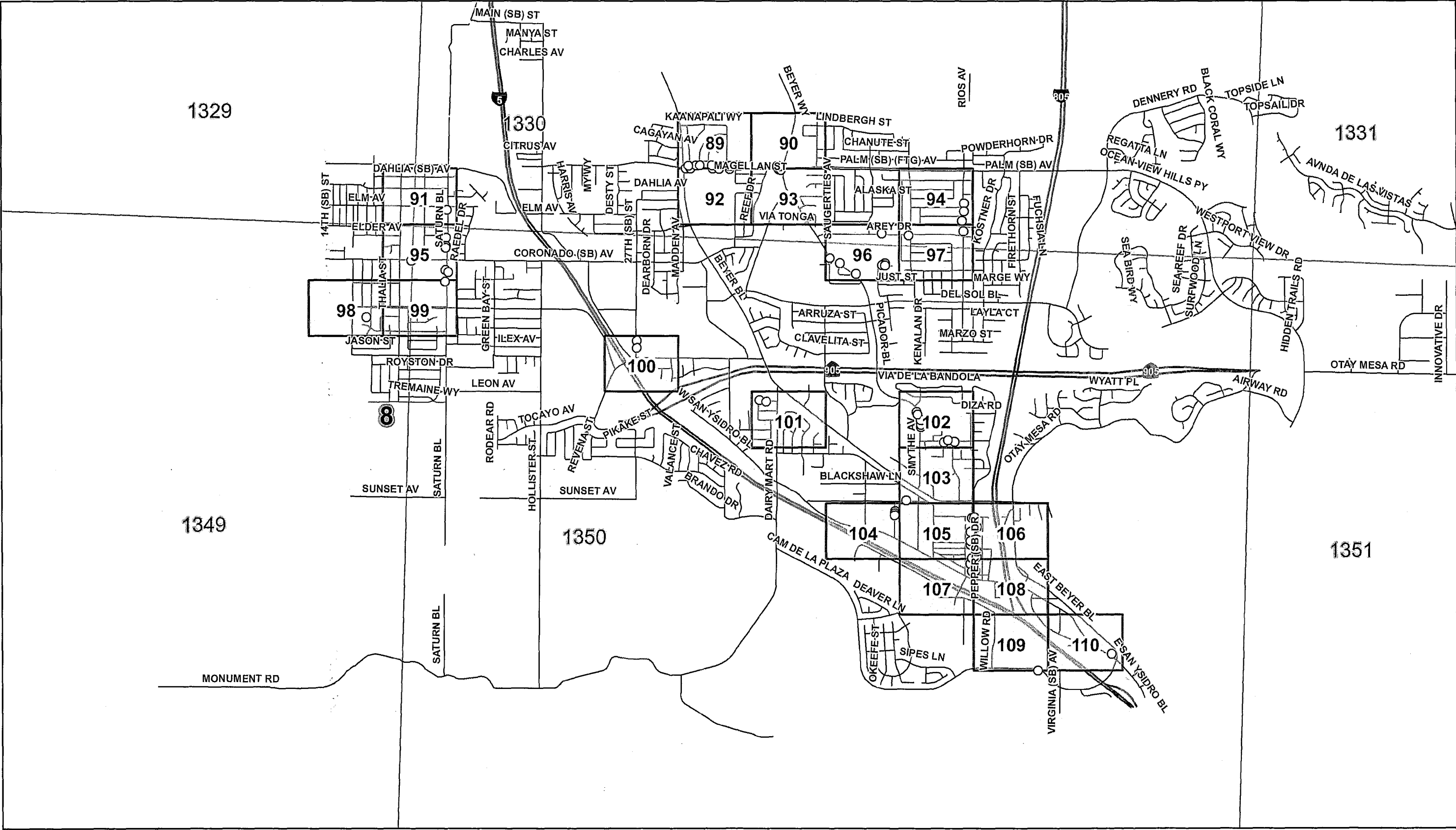







# Sidewalk Replacement Group 1601

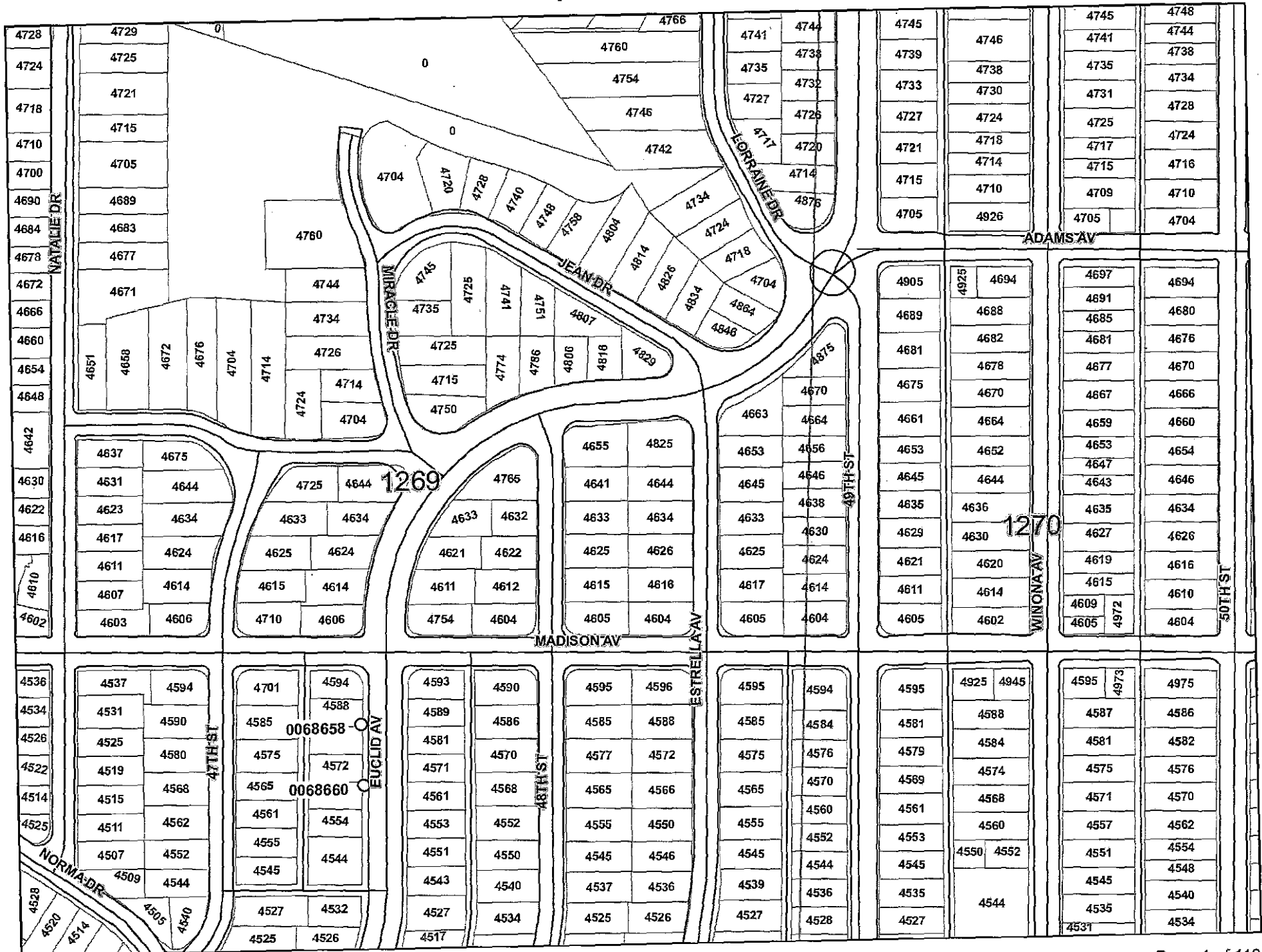

8.5x11

0 125 250 500 Feet

# Sidewalk Replacement Group 1601

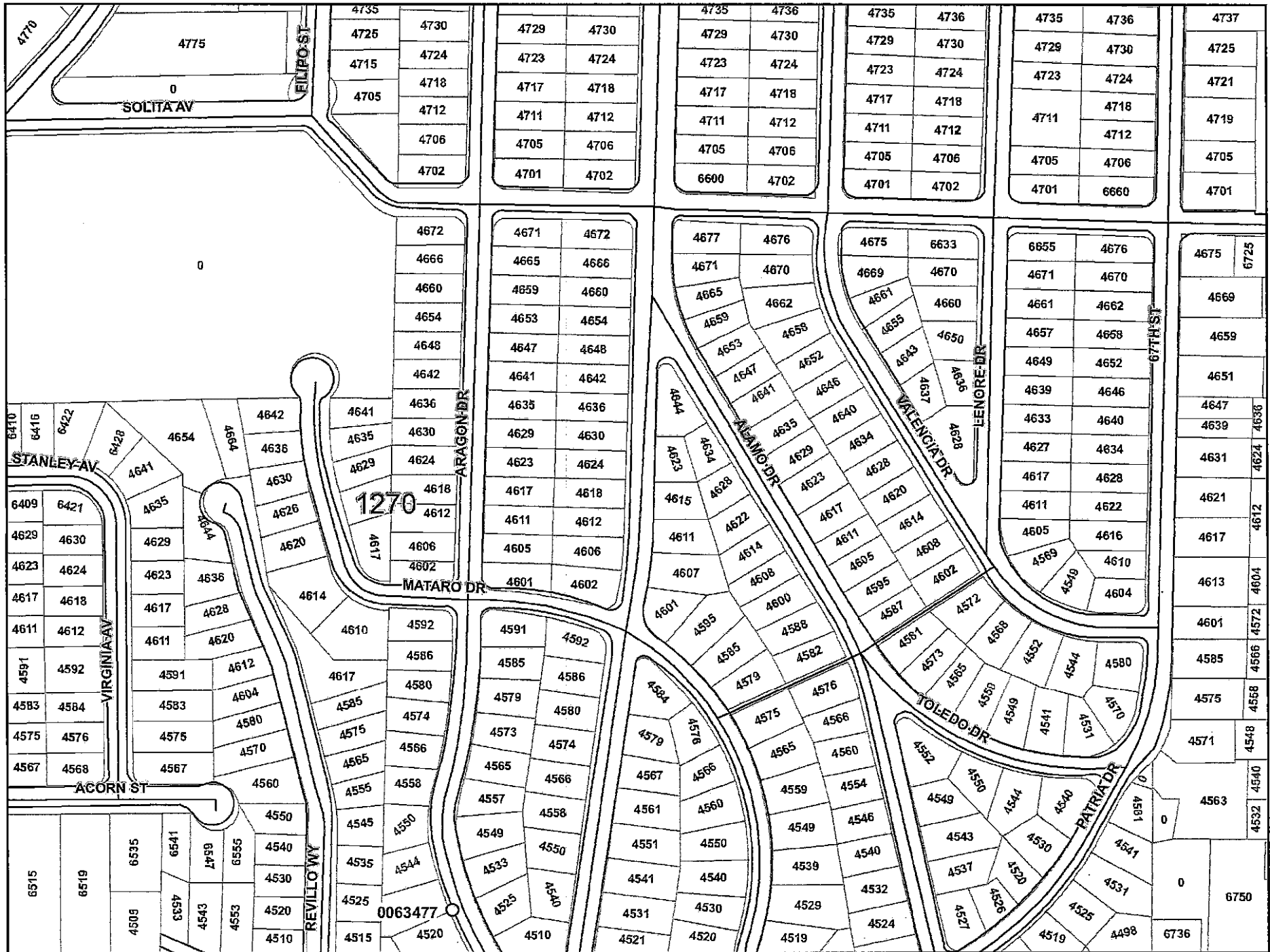

# Sidewalk Replacement Group 1601

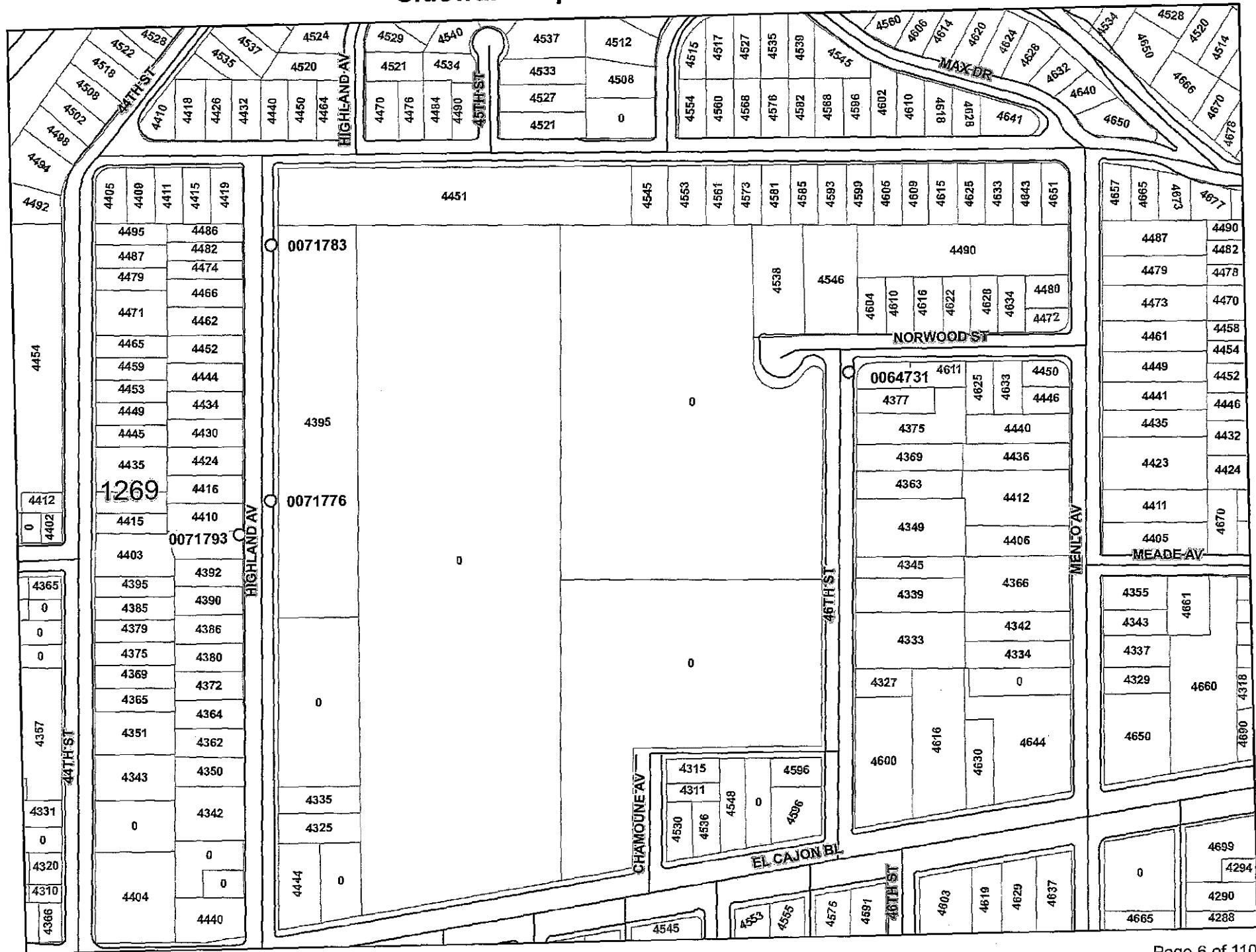

# Sidewalk Replacement Group 1601



# Sidewalk Replacement Group 1601

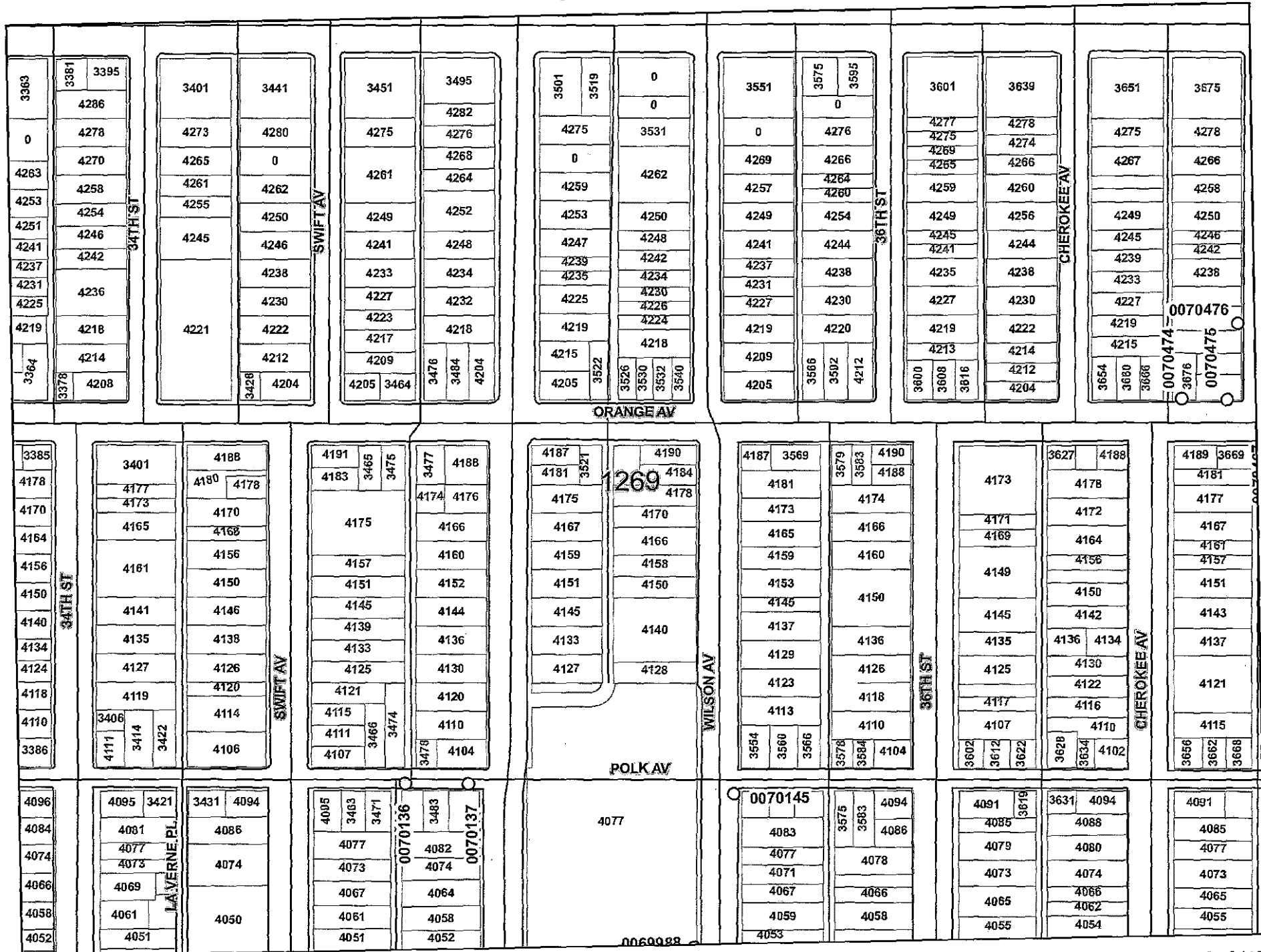



# Sidewalk Replacement Group 1601

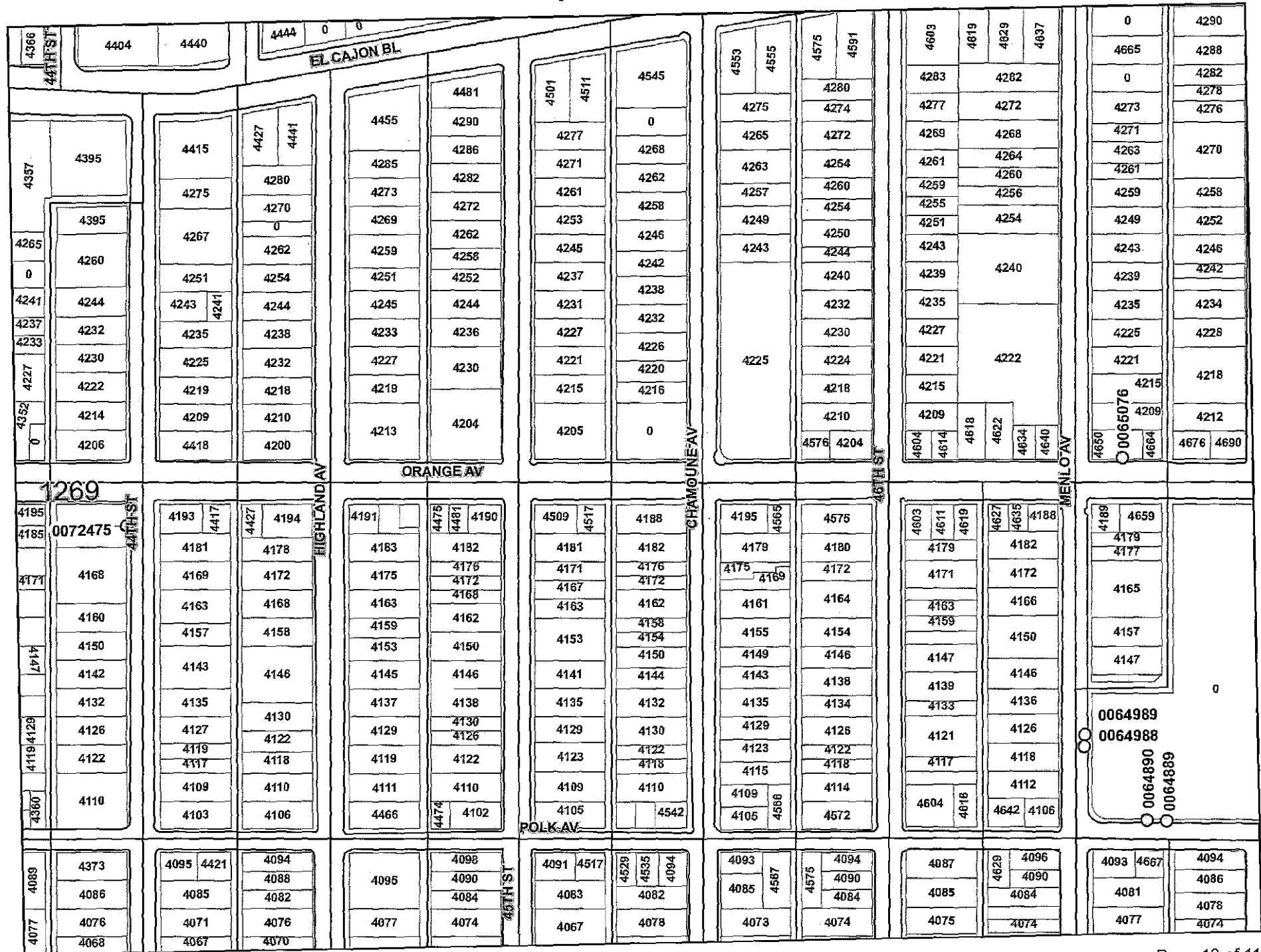



# Sidewalk Replacement Group 1601



# Sidewalk Replacement Group 1601





# Sidewalk Replacement Group 1601

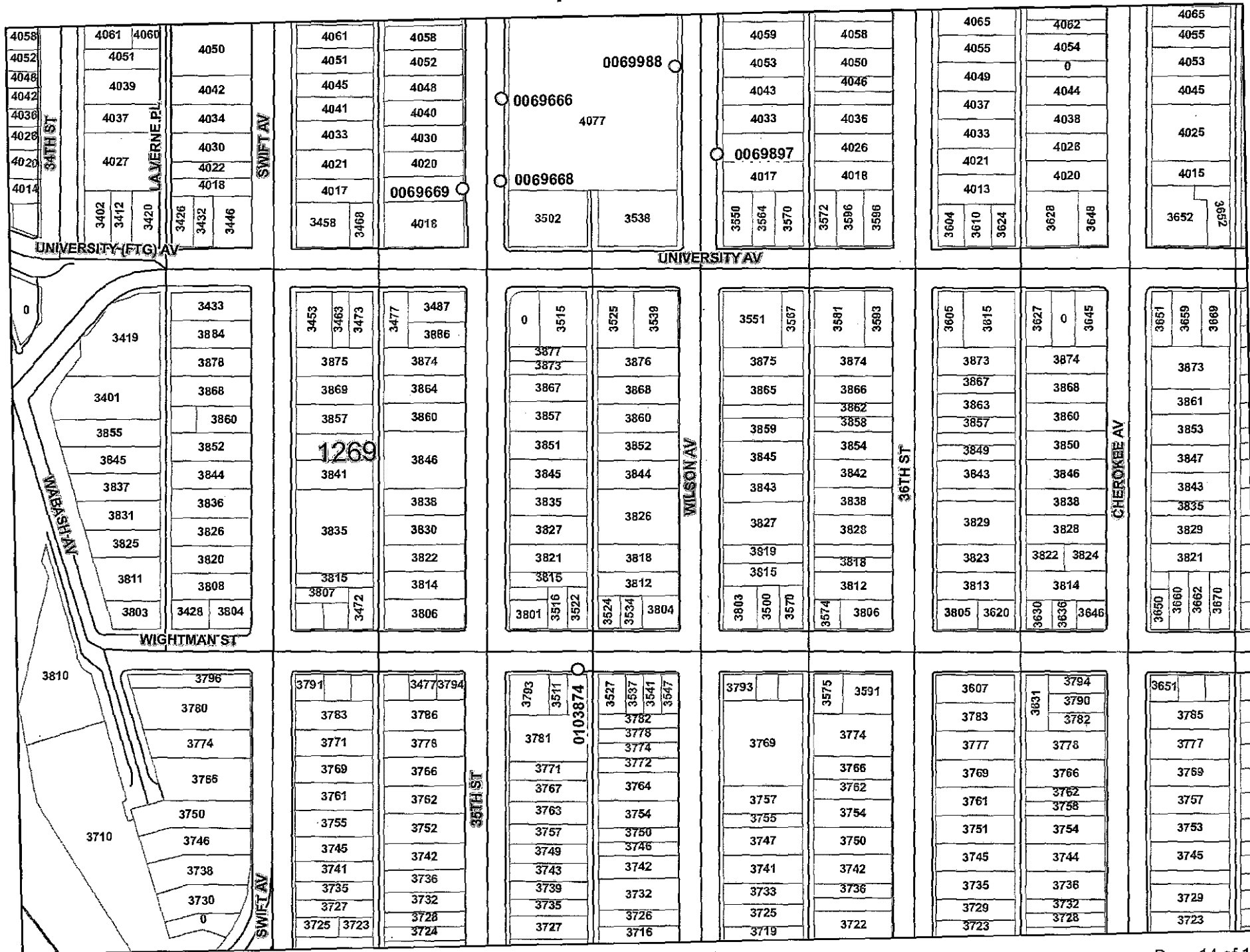

8.5x11

Sidewalk Replacement Group 1601 Appendix E - Location Maps (Rev. Aug 2016)

0 125 250 500 Feet

# Sidewalk Replacement Group 1601

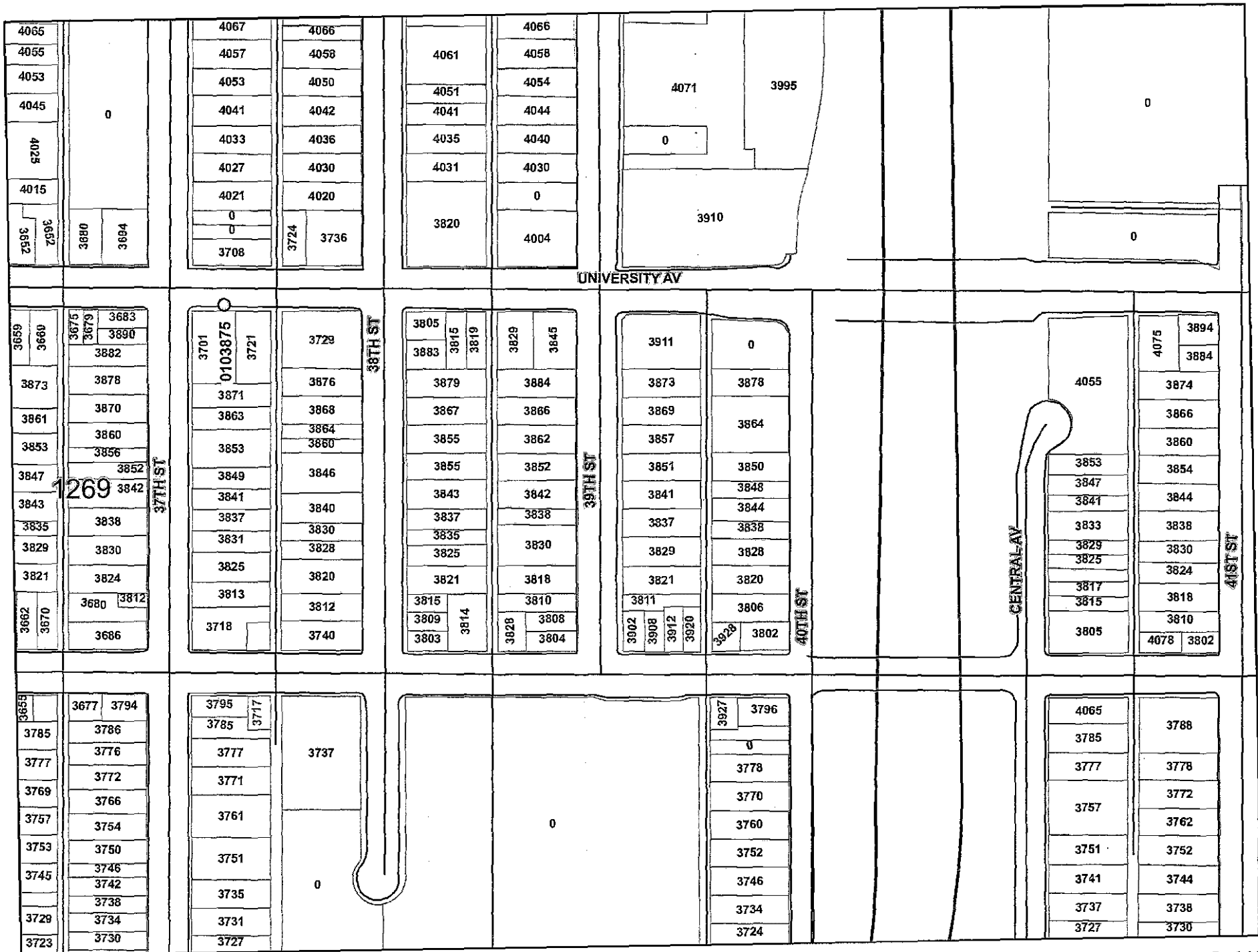

# Sidewalk Replacement Group 1601

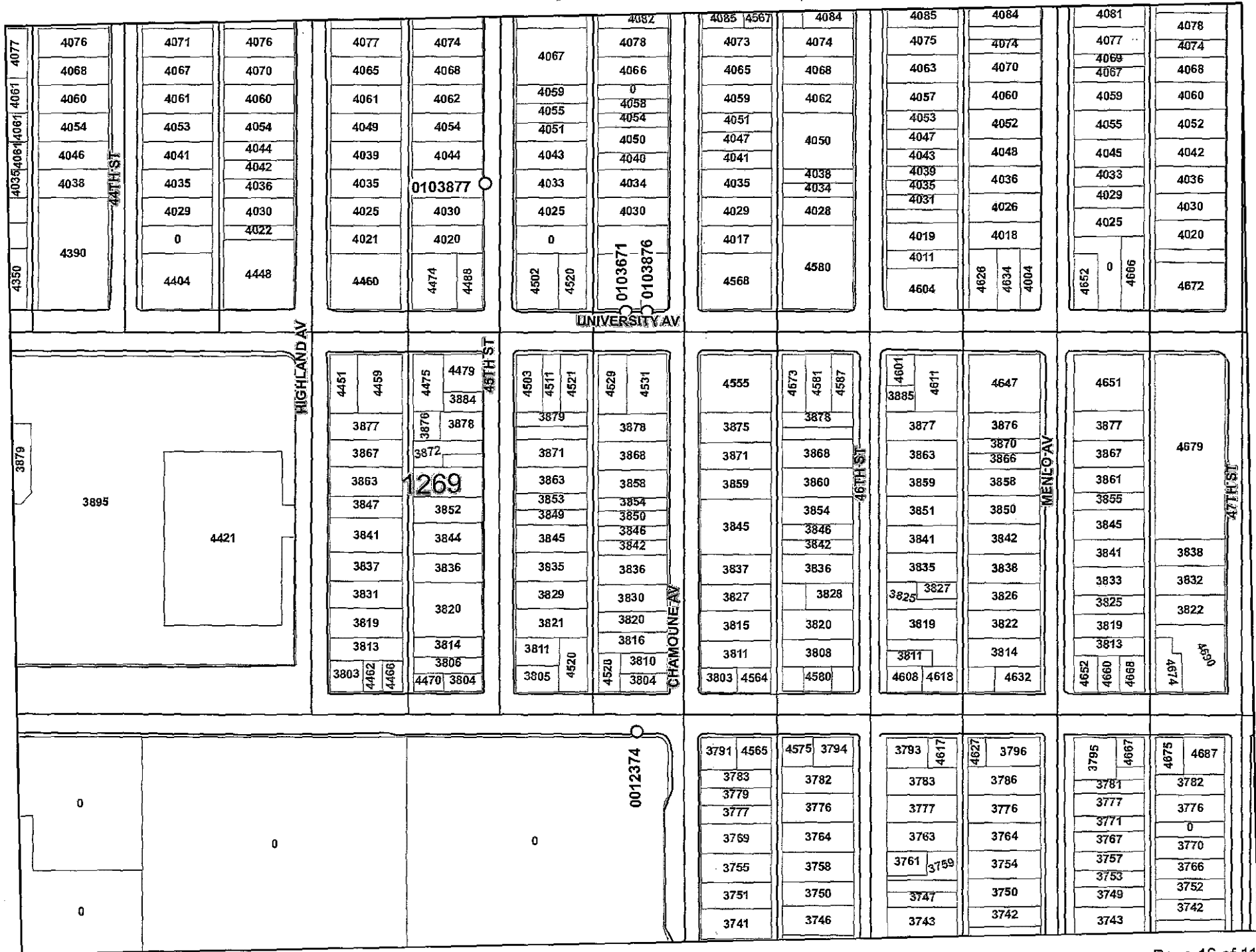

8.5x11

Sidewalk Replacement Group 1601 Appendix E - Location Maps (Rev. Aug. 2016)

0    125    250    500 Feet

# Sidewalk Replacement Group 1601

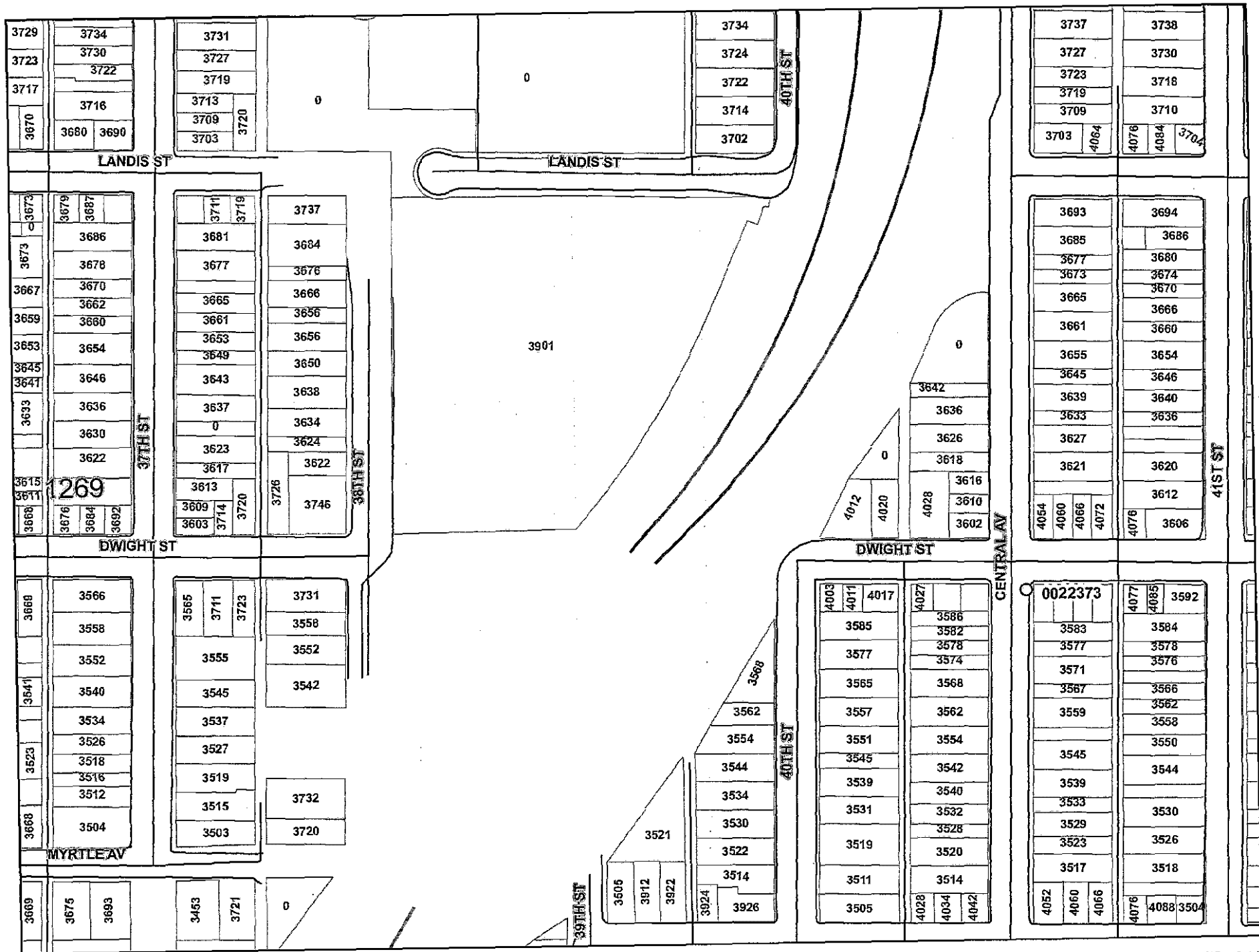

# Sidewalk Replacement Group 1601

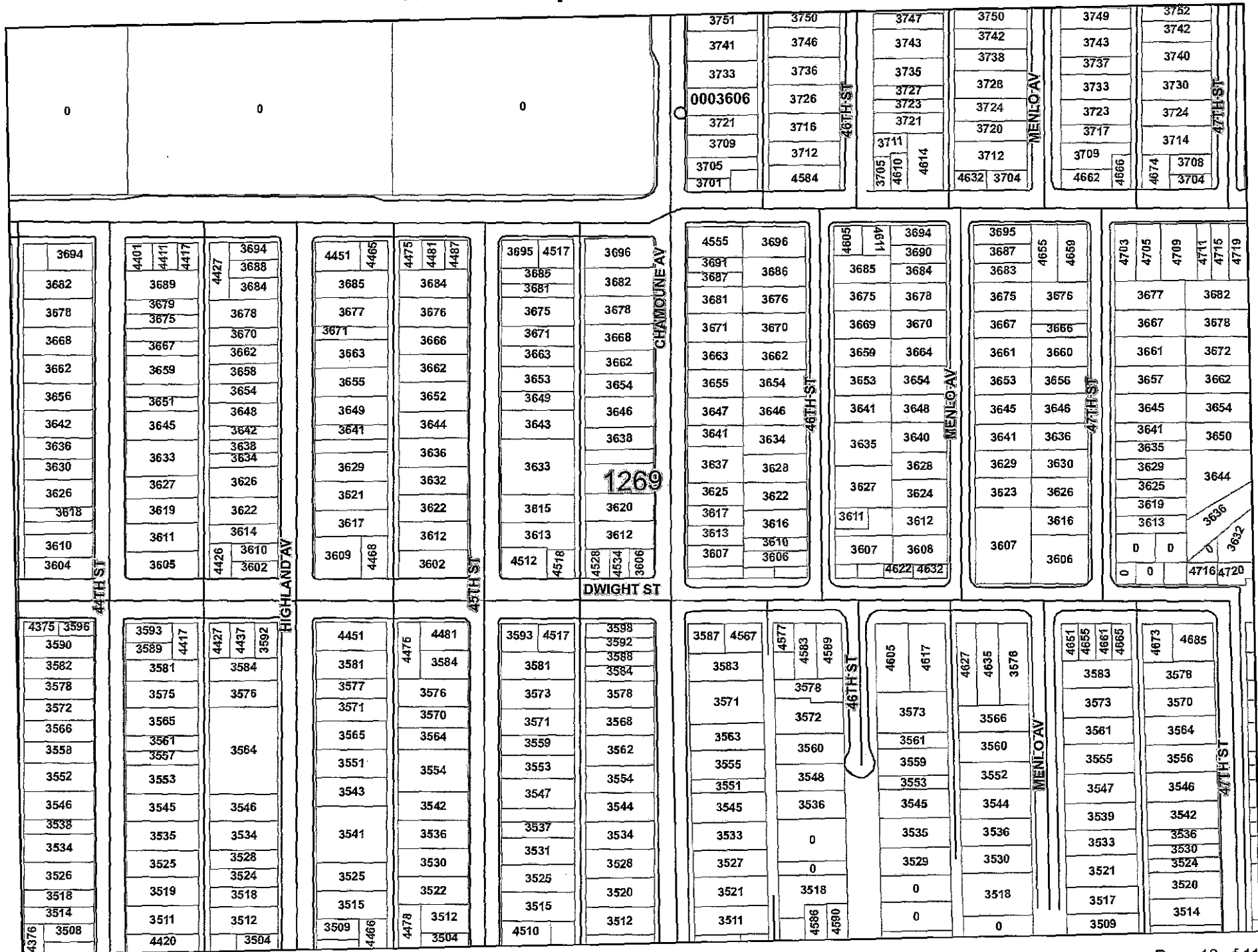

8.5x11

Sidewalk Replacement Group 1601 Appendix E - Location Maps (Rev. Aug. 2016)

0      125      250      500 Feet





# Sidewalk Replacement Group 1601

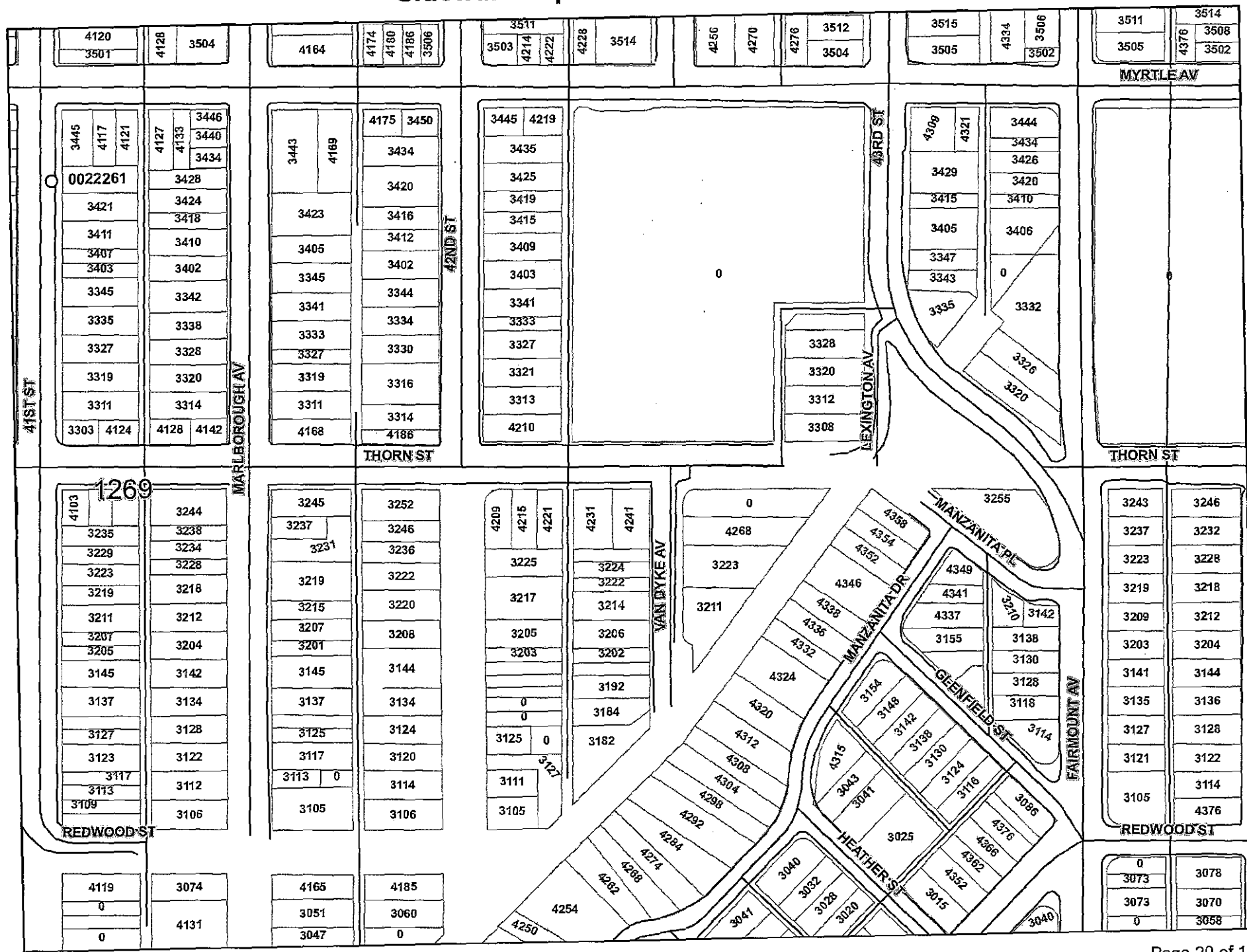

# Sidewalk Replacement Group 1601



8.5x11

0      125      250      500 Feet



# Sidewalk Replacement Group 1601



8.5x11

0 125 250 500 Feet

Sidewalk Replacement Group 1601 Appendix E - Location Maps (Rev. Aug 2016)

Page 23 of 110

94 | Page

# Sidewalk Replacement Group 1601

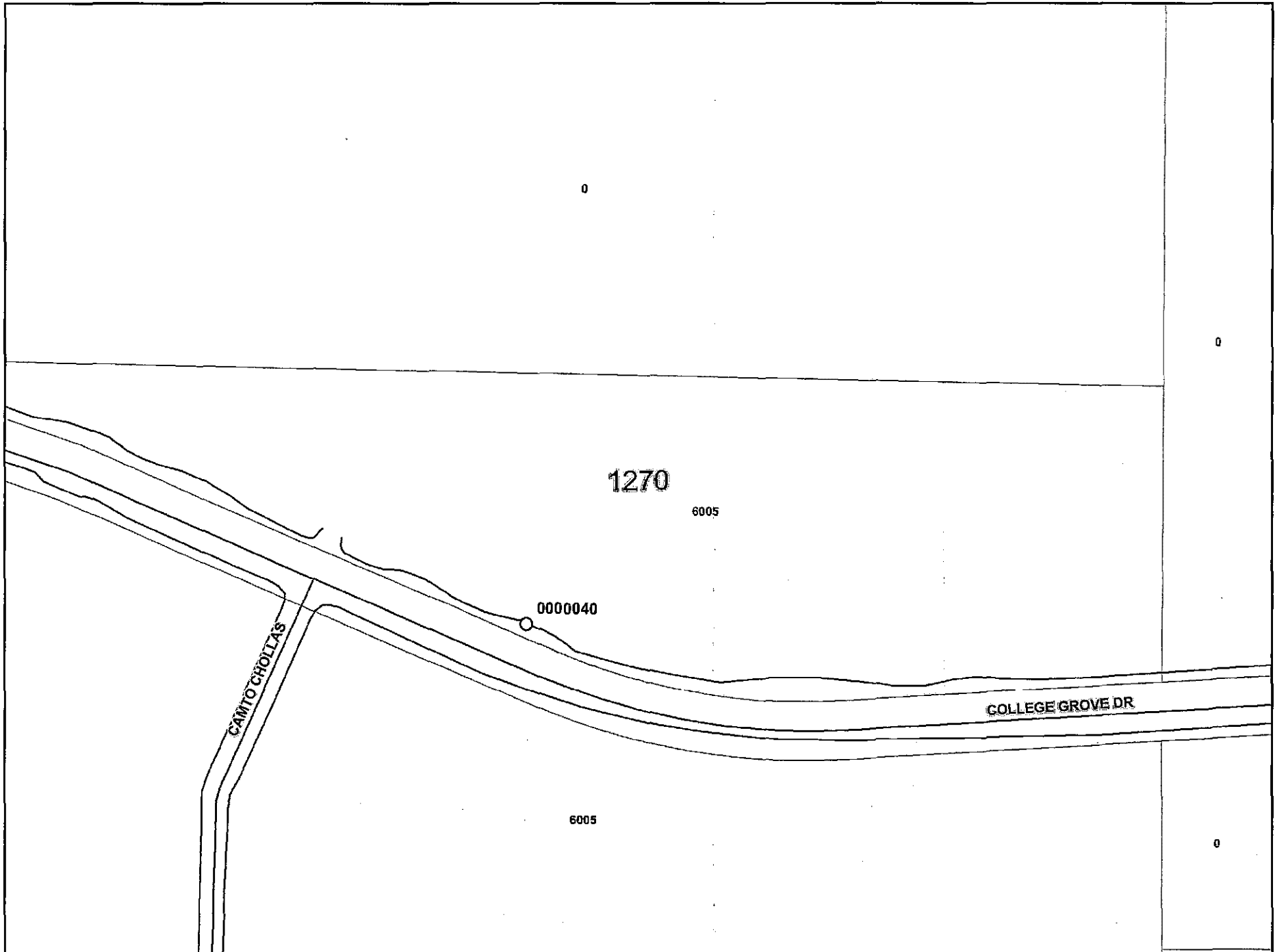

# Sidewalk Replacement Group 1601

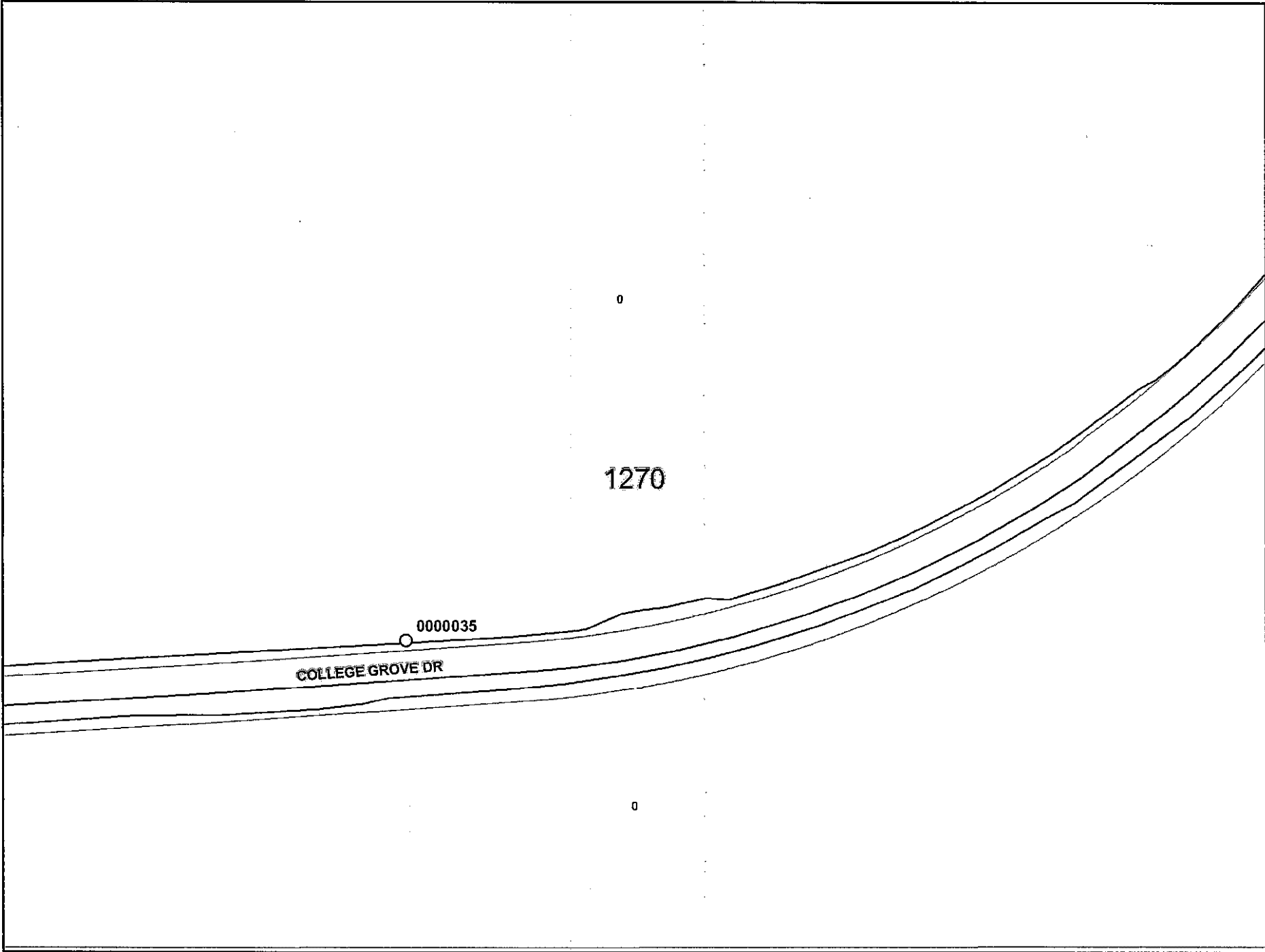

# Sidewalk Replacement Group 1601



8.5x11

0 125 250 500 Feet

Page 26 of 110



# Sidewalk Replacement Group 1601

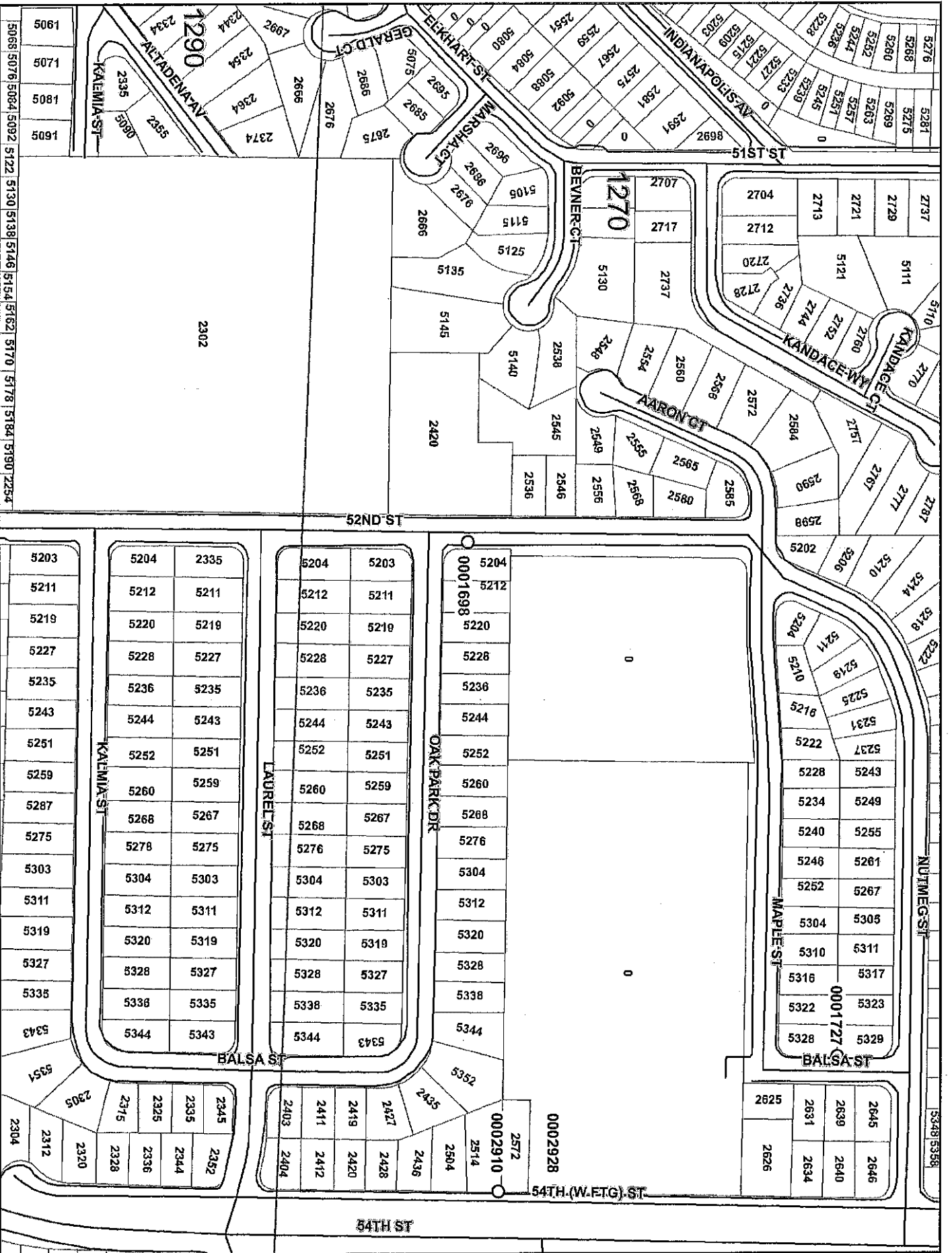





# Sidewalk Replacement Group 1601

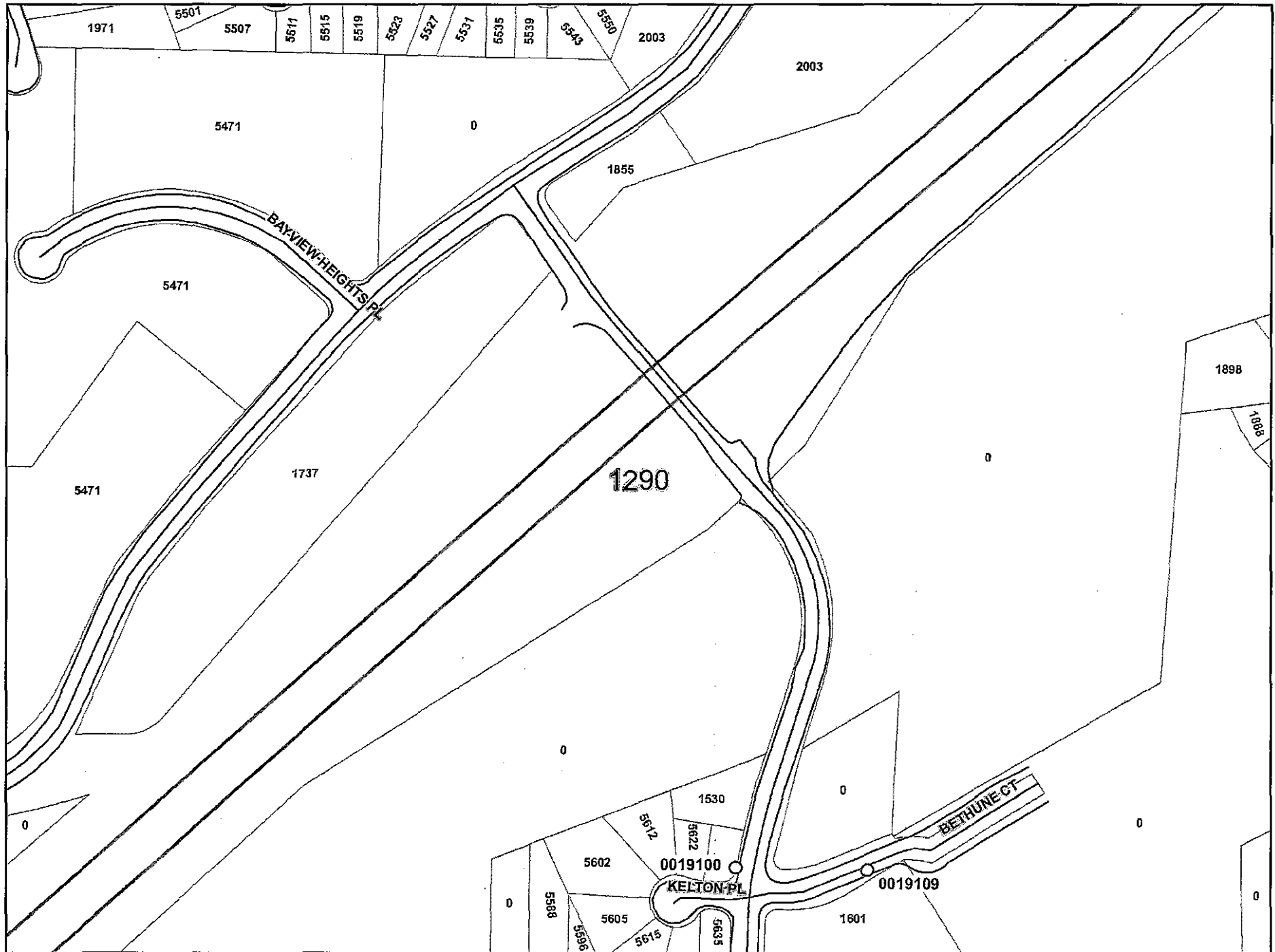

# Sidewalk Replacement Group 1601

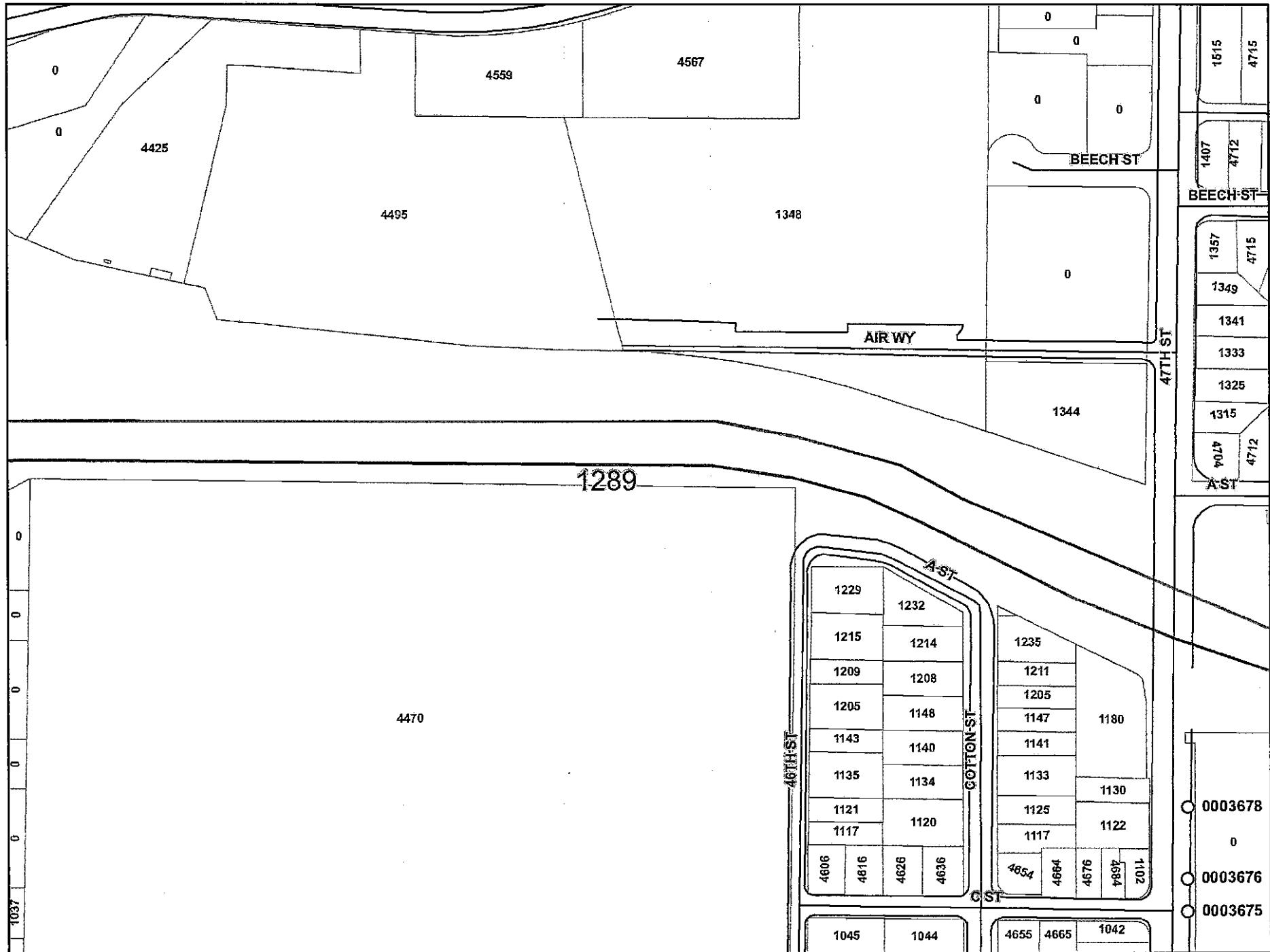

# Sidewalk Replacement Group 1601

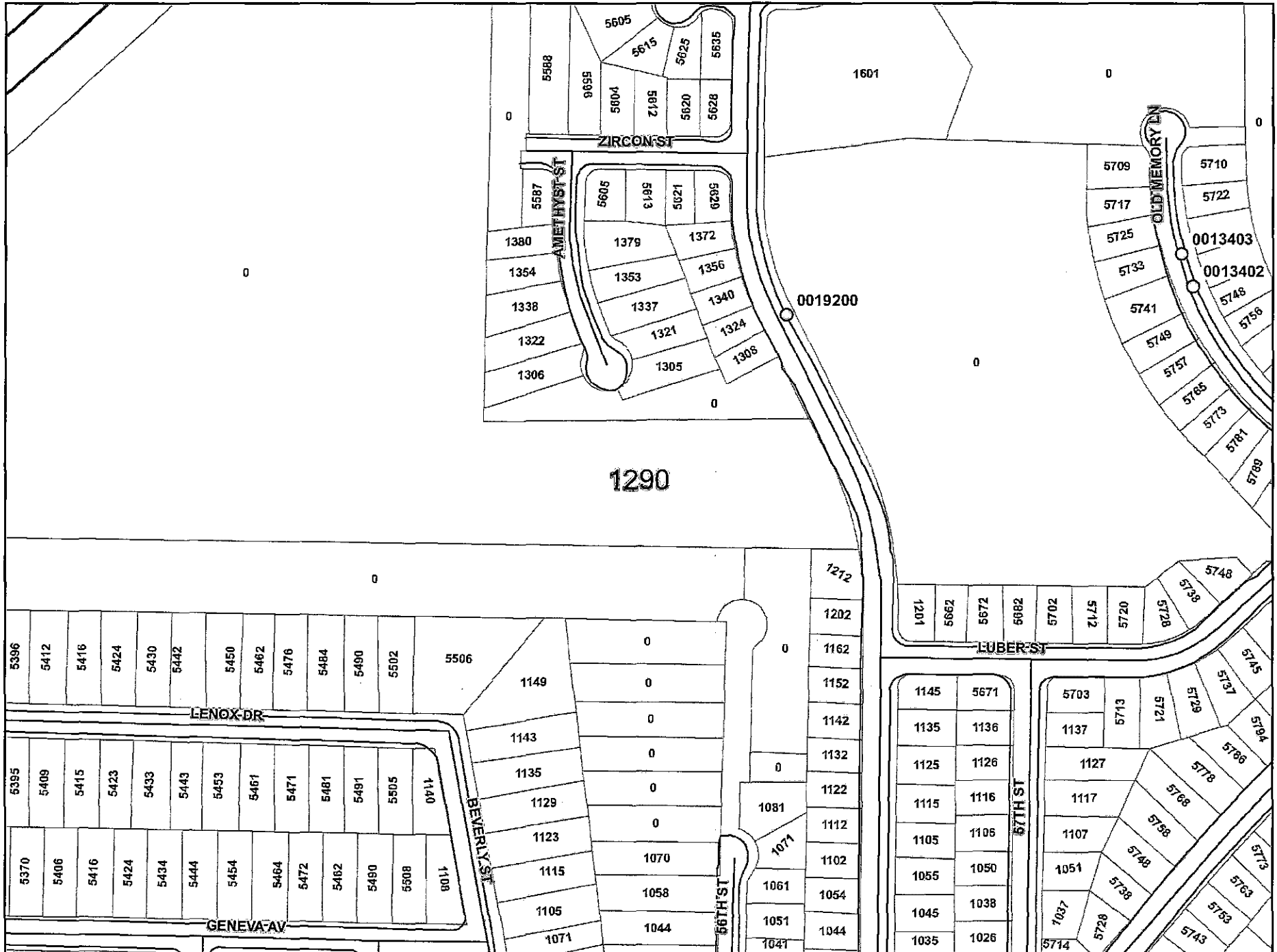



# Sidewalk Replacement Group 1601

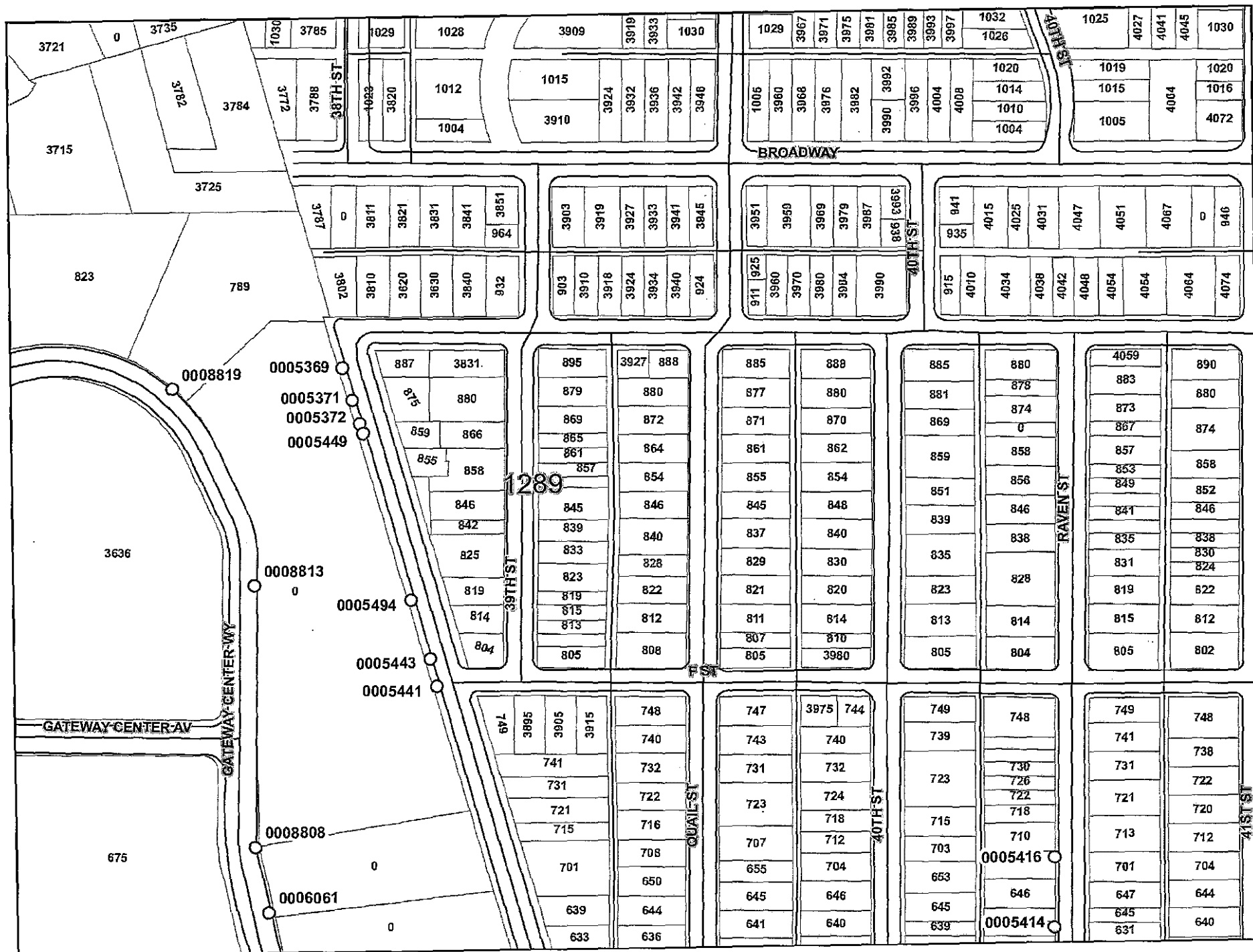



# Sidewalk Replacement Group 1601

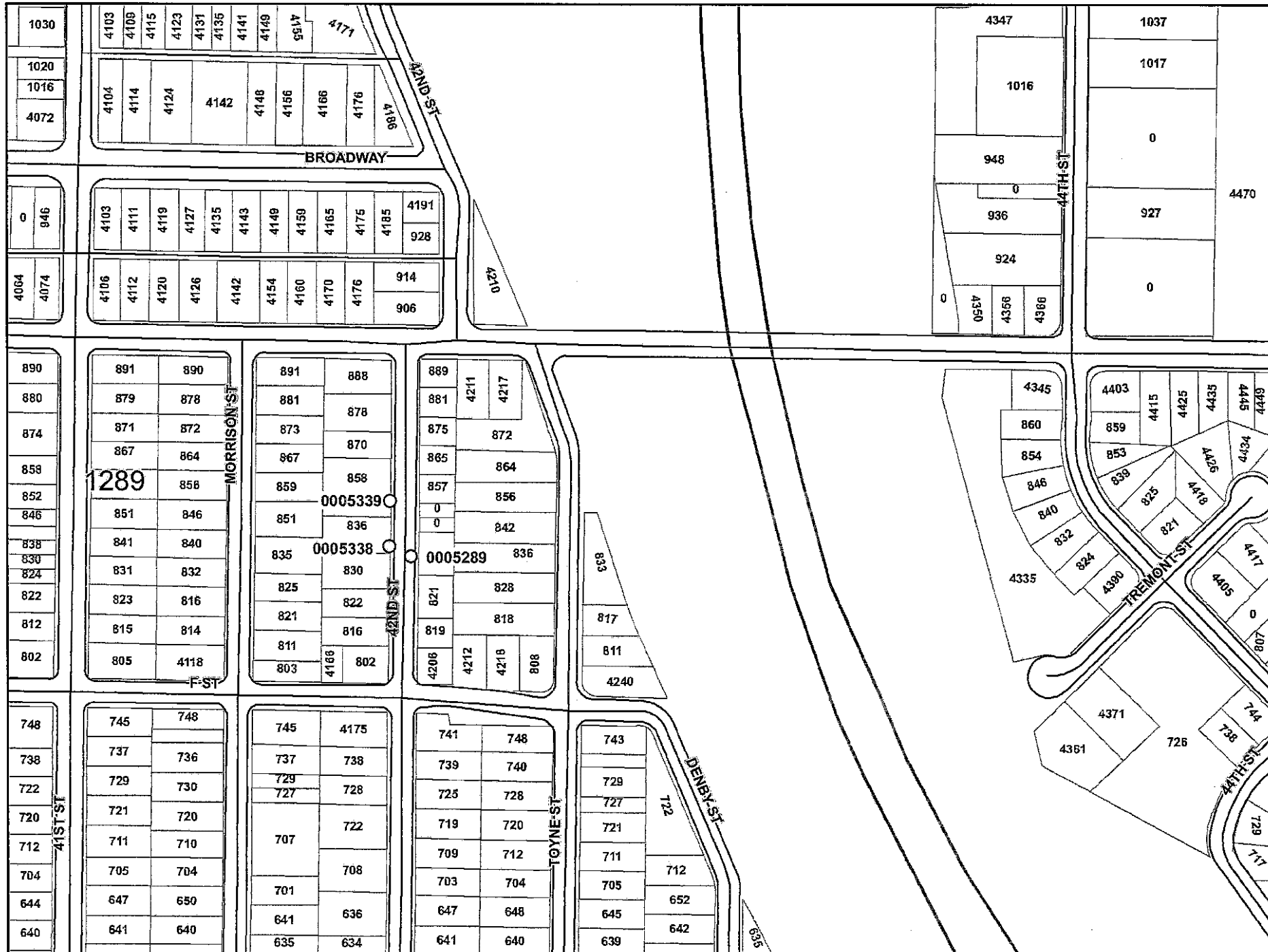

# Sidewalk Replacement Group 1601

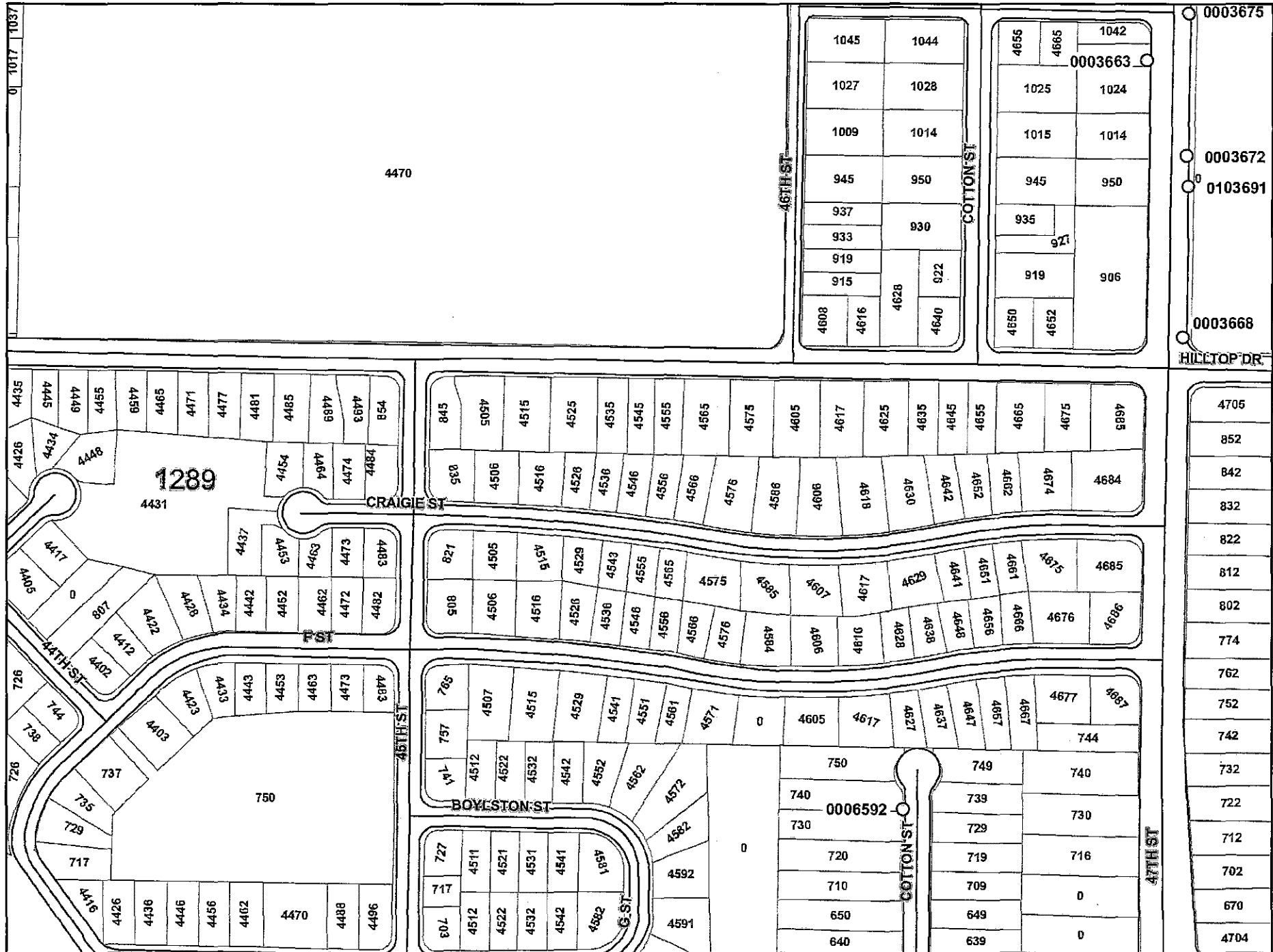





# Sidewalk Replacement Group 1601



# Sidewalk Replacement Group 1601

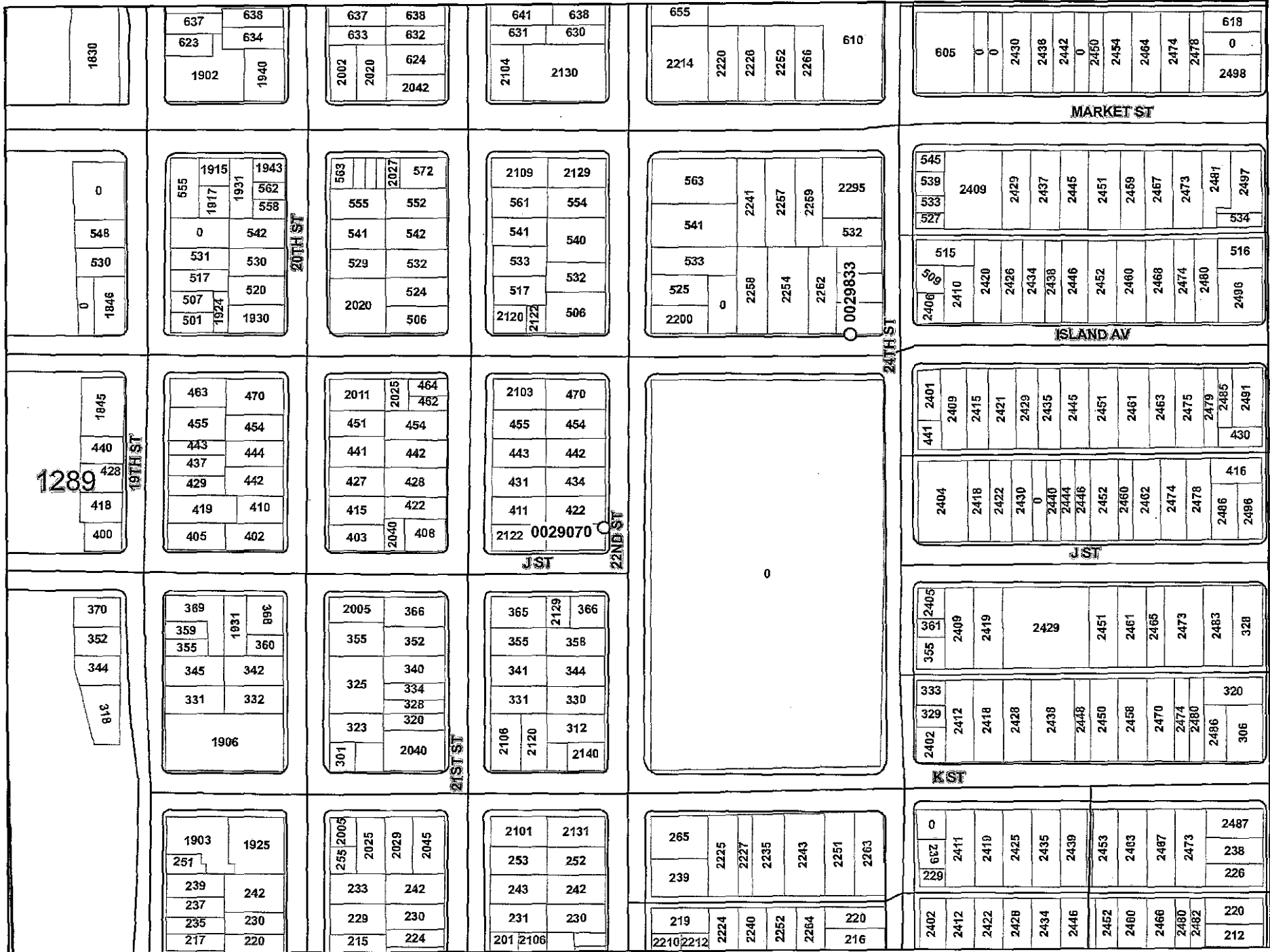



# Sidewalk Replacement Group 1601











# Sidewalk Replacement Group 1601



# Sidewalk Replacement Group 1601



# Sidewalk Replacement Group 1601

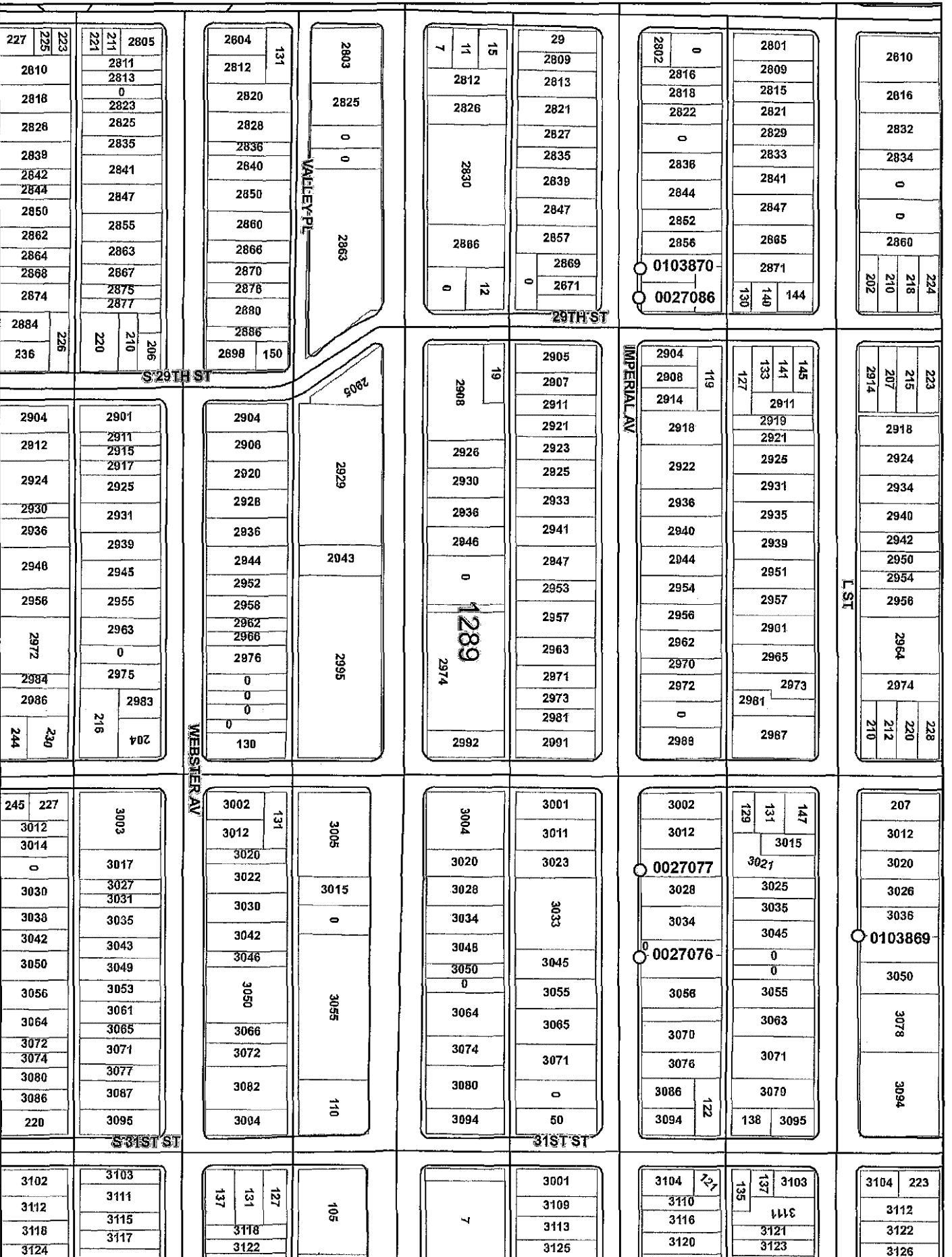

2810
2816
2832
2834
0
0
2860
218
210
202
224

2801
2809
2815
2821
2829
2833
2841
2847
2865
2871
144
140
130

0
2816
2818
2822
0
2836
2844
2852
2856
0103870
0027086
2802

29
2809
2813
2821
2827
2835
2839
2847
2857
2869
2871
0

15
11
2812
2826
2830
2866
12
0
7

2803
2825
0
0
2863

131
2812
2820
2828
2836
2840
2850
2860
2866
2870
2876
2880
2886
2898
150

2805
2811
2813
0
2823
2825
2835
2841
2847
2855
2863
2867
2875
2877
206
210
220

223
225
2810
2816
2828
2839
2842
2844
2850
2862
2864
2868
2874
2884
236
226

223
215
207
2914
2918
2924
2934
2940
2942
2950
2954
2956
2964
2974
210
212
220
228

145
141
133
127
2911
2919
2921
2925
2931
2935
2939
2951
2957
2901
2965
2973
2981
2967

2904
2908
2914
2918
2922
2936
2940
2944
2954
2956
2962
2970
2972
0
2988
119

2905
2907
2911
2921
2923
2925
2933
2941
2947
2953
2957
2963
2971
2973
2981
2991

19
2908
2926
2930
2936
2946
0
1289
2974
2992

2905
2929
2943
2995

2904
2906
2920
2928
2936
2944
2952
2958
2962
2966
2976
0
0
0
0
130

2901
2911
2915
2917
2925
2931
2939
2945
2955
2963
0
2975
2983
204
216

2904
2812
2924
2930
2936
2948
2956
2972
2984
2986
244
230

207
3012
3020
3026
3036
0103869
3050
3078
3094

147
131
129
3015
3021
3025
3035
3045
0
0
3055
3063
3071
3079
3095
138

3002
3012
0027077
3028
3034
0027076
3058
3070
3076
3086
3094
122

3001
3011
3023
3033
3045
3055
3065
3071
0
50
3094

3004
3020
3028
3034
3048
3050
0
3064
3074
3080
3094

3005
3015
0
3055
110

131
3002
3012
3020
3022
3030
3042
3046
3050
3066
3072
3082
3004

3003
3017
3027
3031
3035
3043
3049
3053
3061
3065
3071
3077
3087
3095

245
227
3012
3014
0
3030
3038
3042
3050
3056
3064
3072
3074
3080
3086
220

3104
223
3112
3122
3126

3103
137
135
1113
3121
3123

3104
227
3110
3116
3120

3001
3109
3113
3125
7

105
-----

127
131
137
3118
3122

3103
3111
3115
3117

3102
3112
3118
3124

# Sidewalk Replacement Group 1601

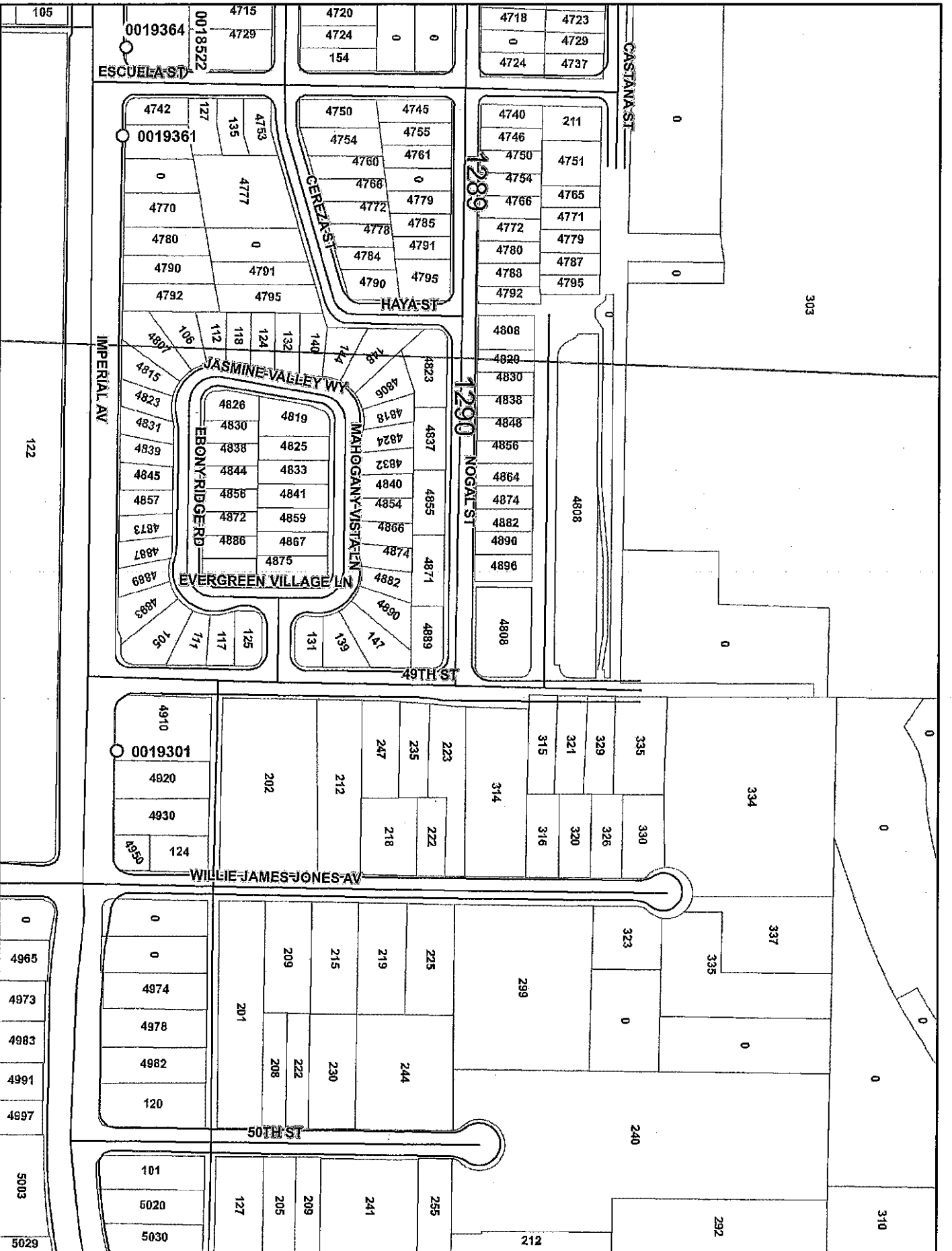

# Sidewalk Replacement Group 1601





# Sidewalk Replacement Group 1601



# Sidewalk Replacement Group 1601



# Sidewalk Replacement Group 1601

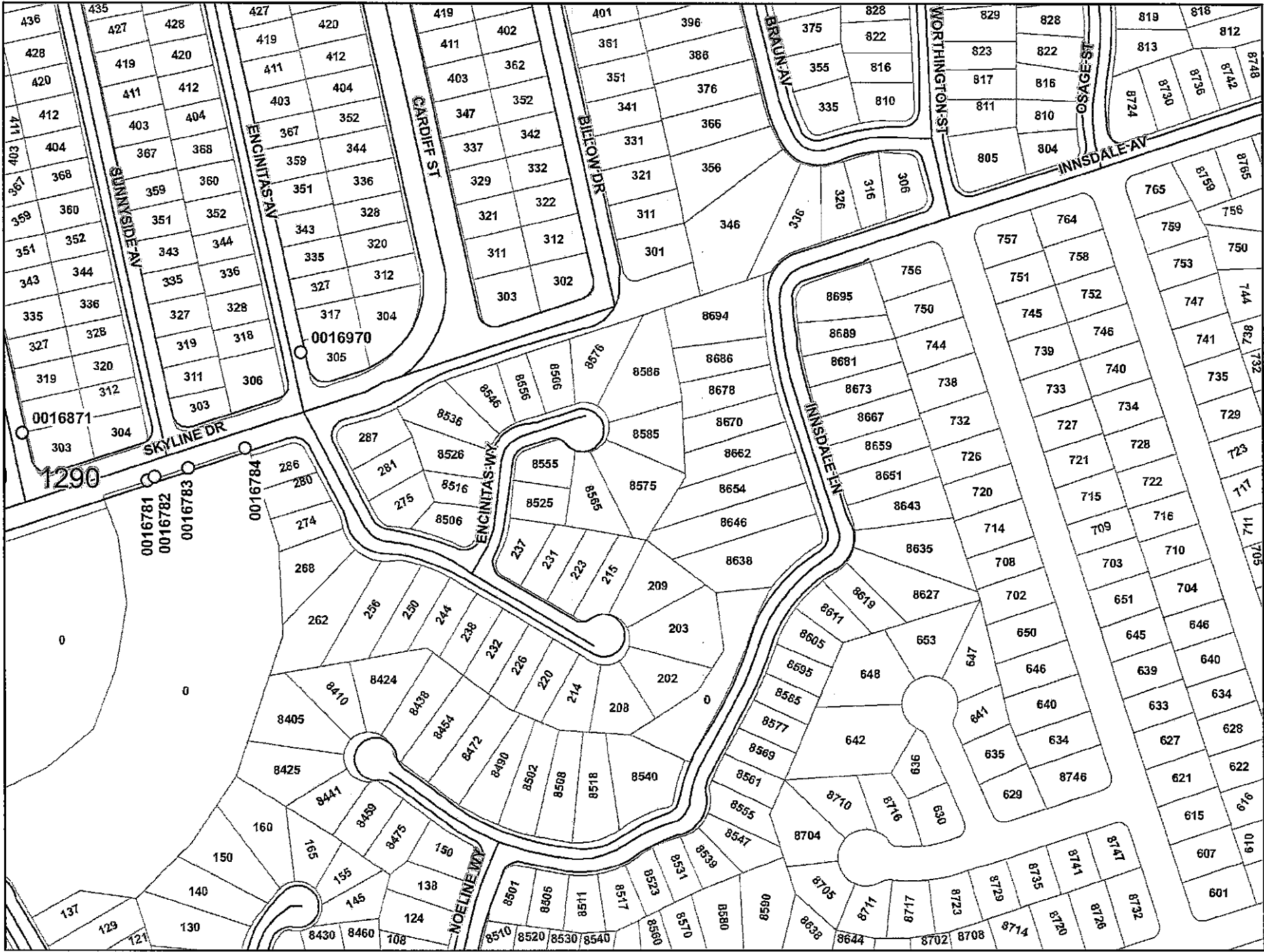

8.5x11

0 125 250 500 Feet

Page 53 of 110





# Sidewalk Replacement Group 1601

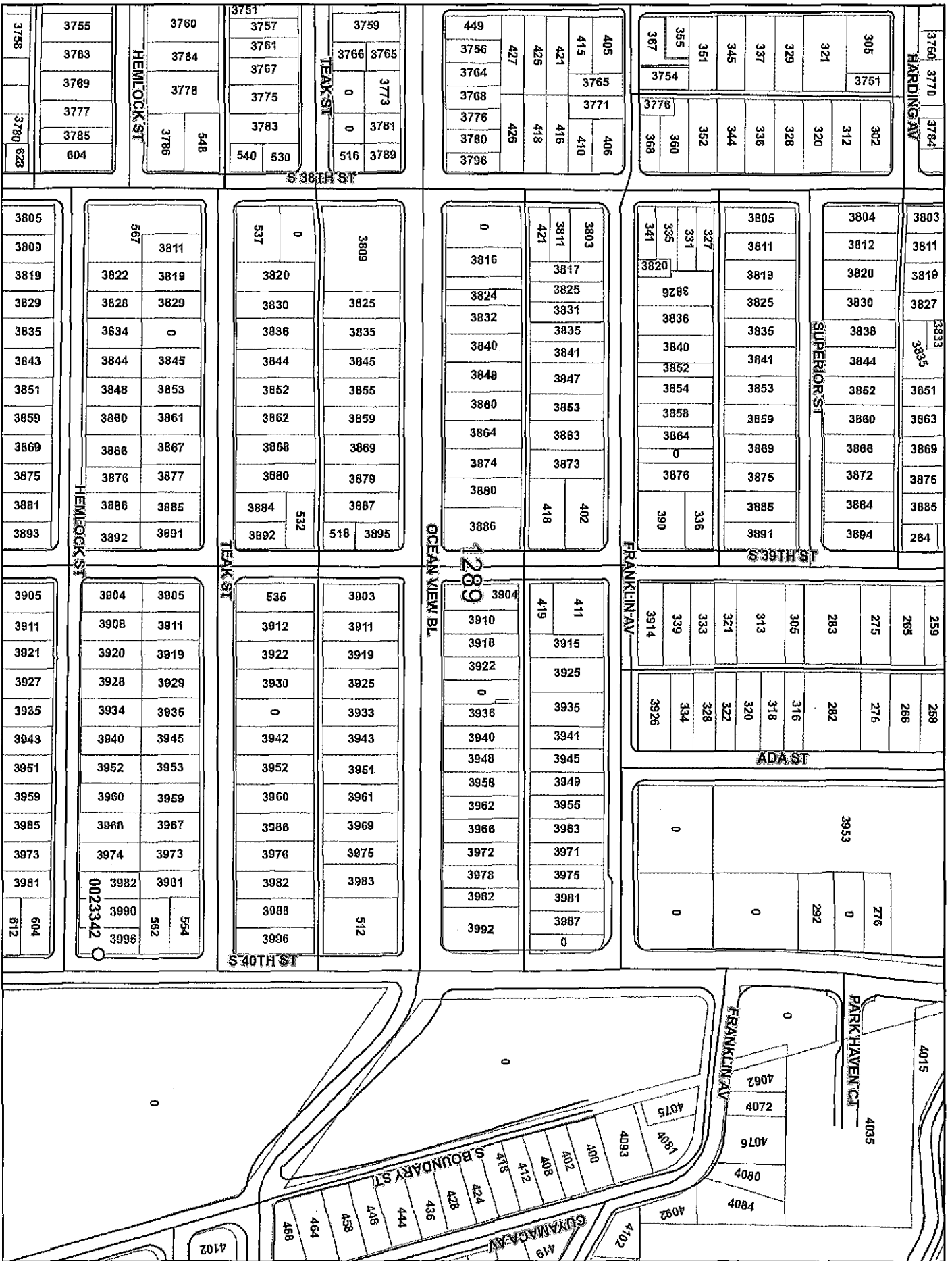

# Sidewalk Replacement Group 1601

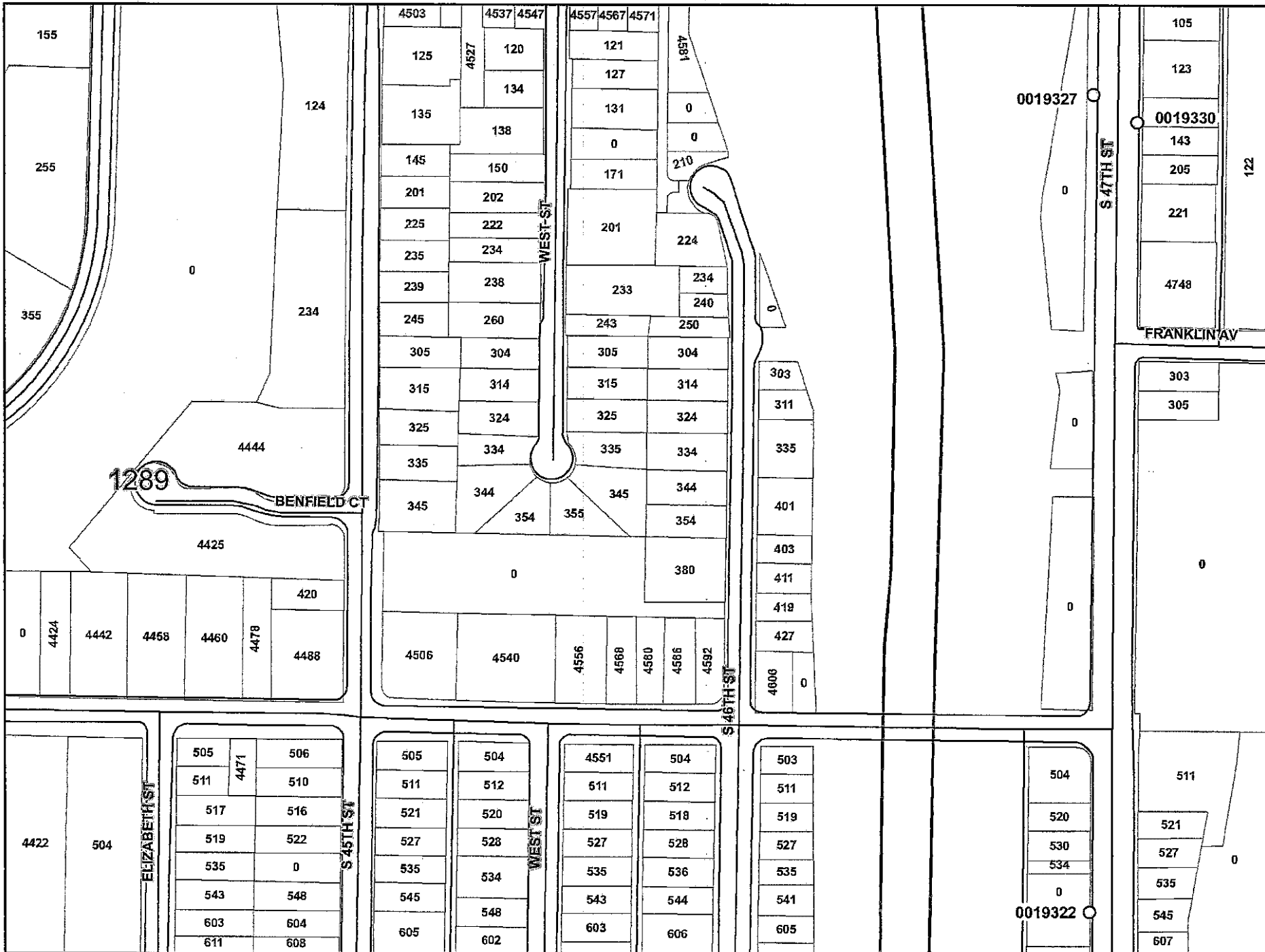

8.5x11

0 125 250 500 Feet

Page 57 of 110

# Sidewalk Replacement Group 1601

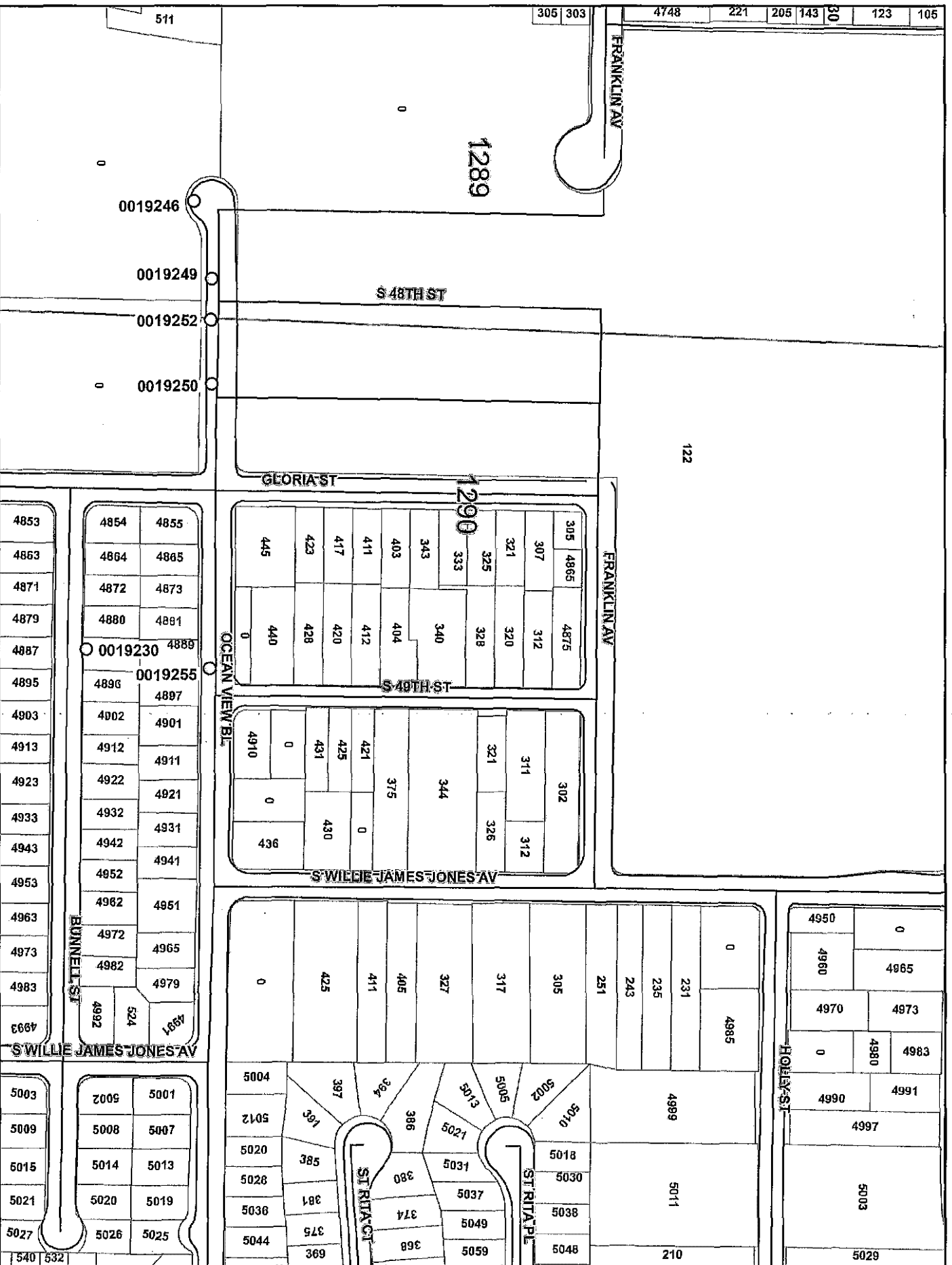



# Sidewalk Replacement Group 1601

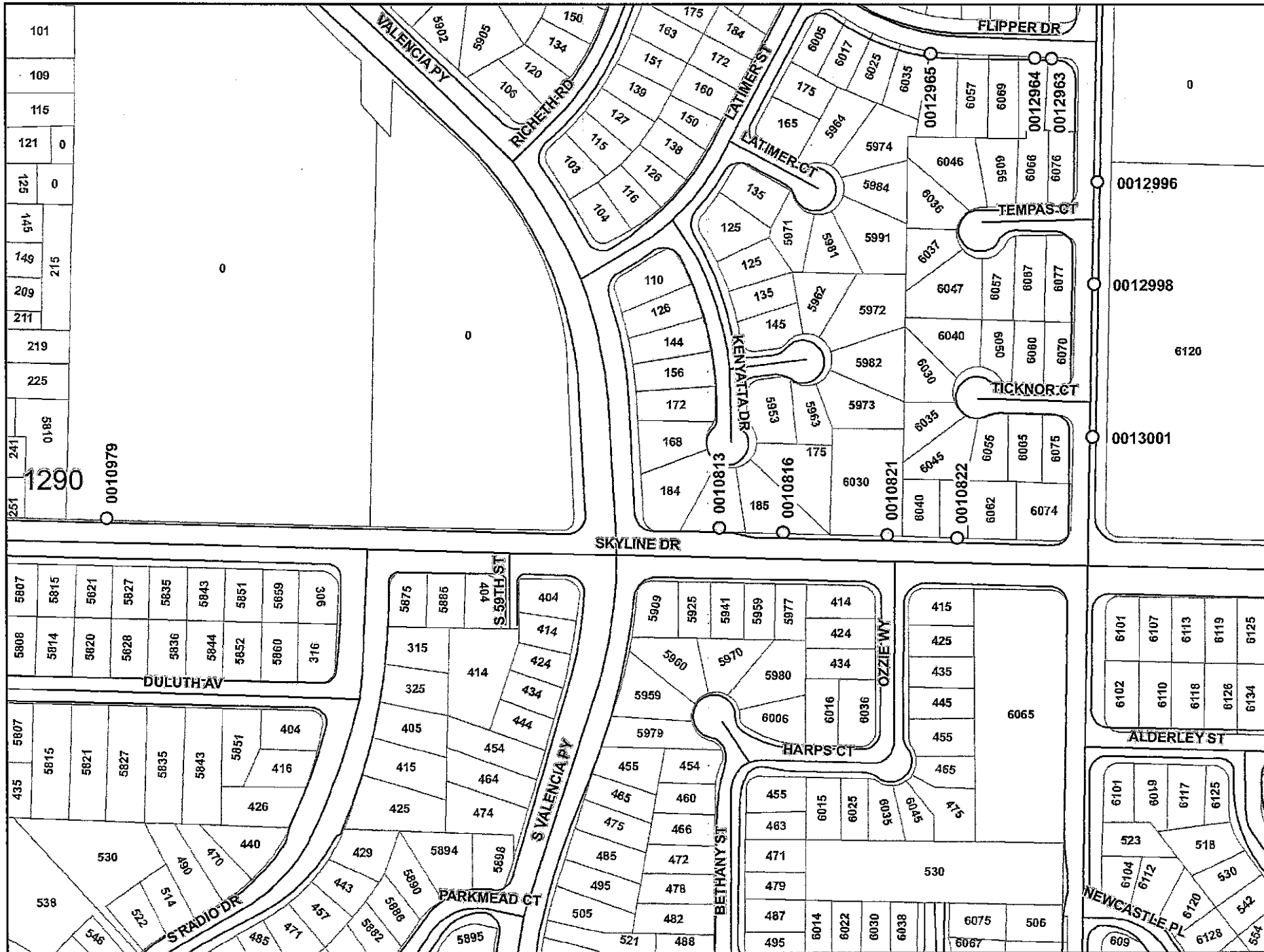

8.5x11

0 125 250 500 Feet

Page 59 of 110

# Sidewalk Replacement Group 1601

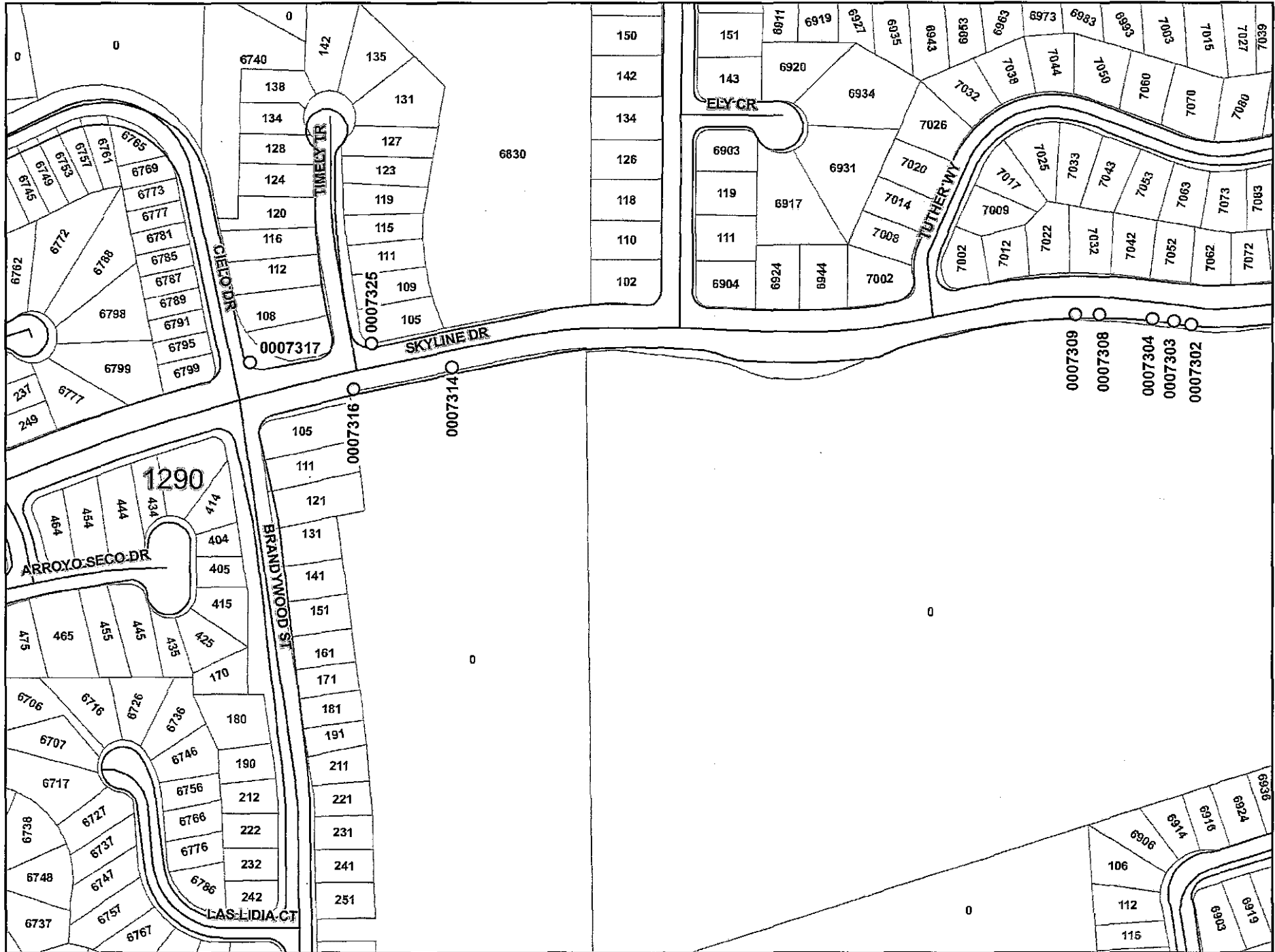

# Sidewalk Replacement Group 1601



# Sidewalk Replacement Group 1601

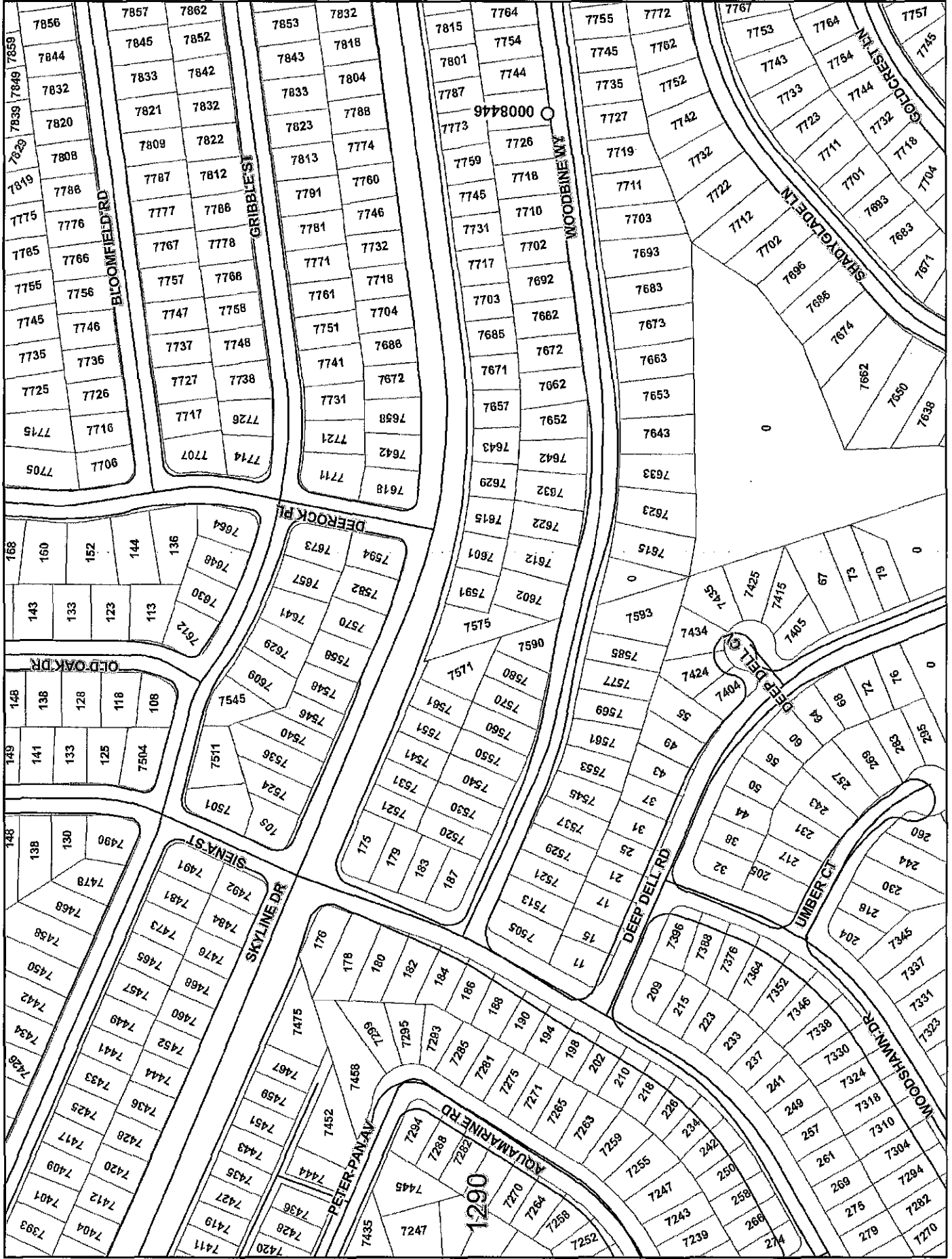

# Sidewalk Replacement Group 1601



# Sidewalk Replacement Group 1601

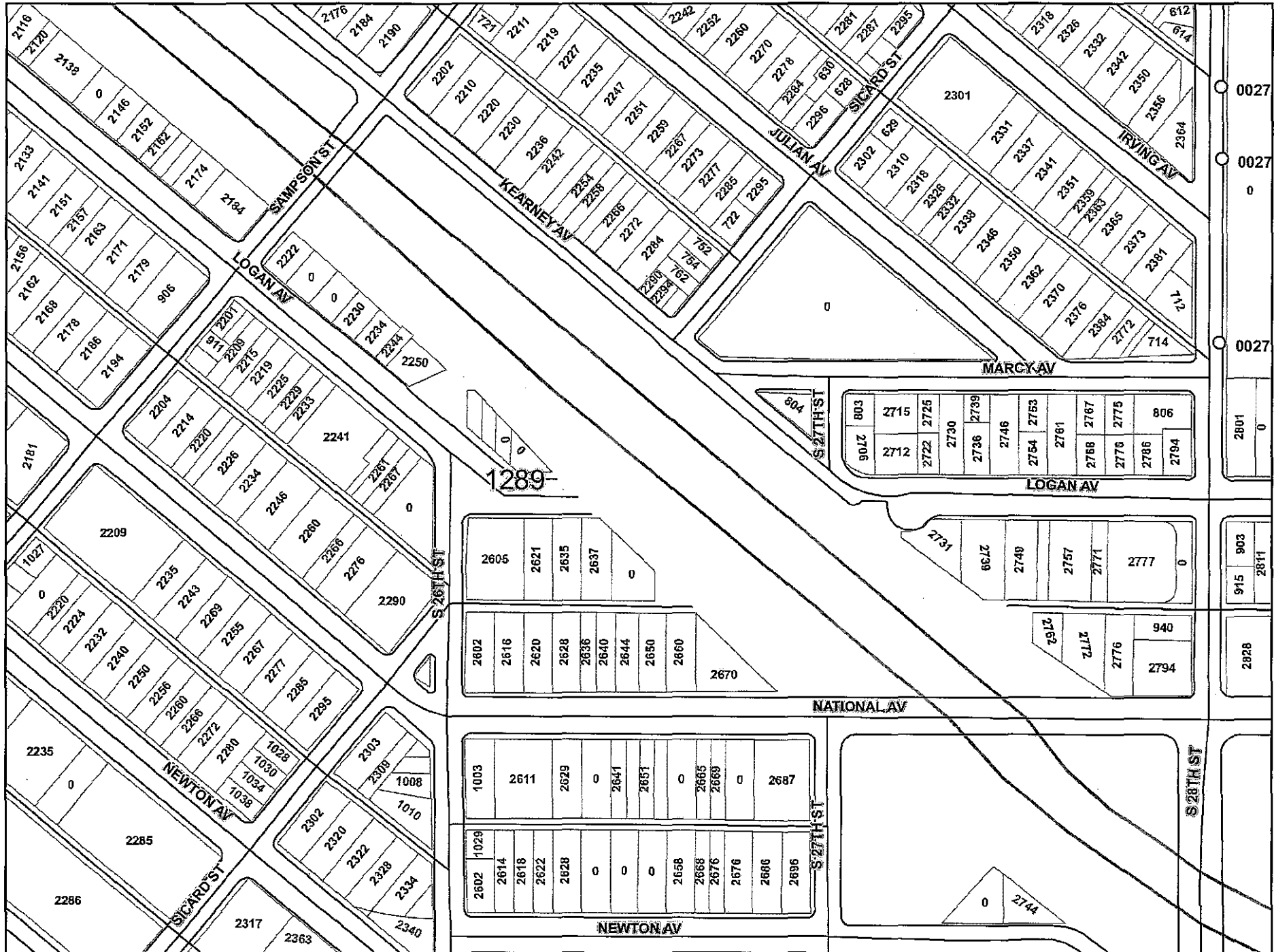

# Sidewalk Replacement Group 1601

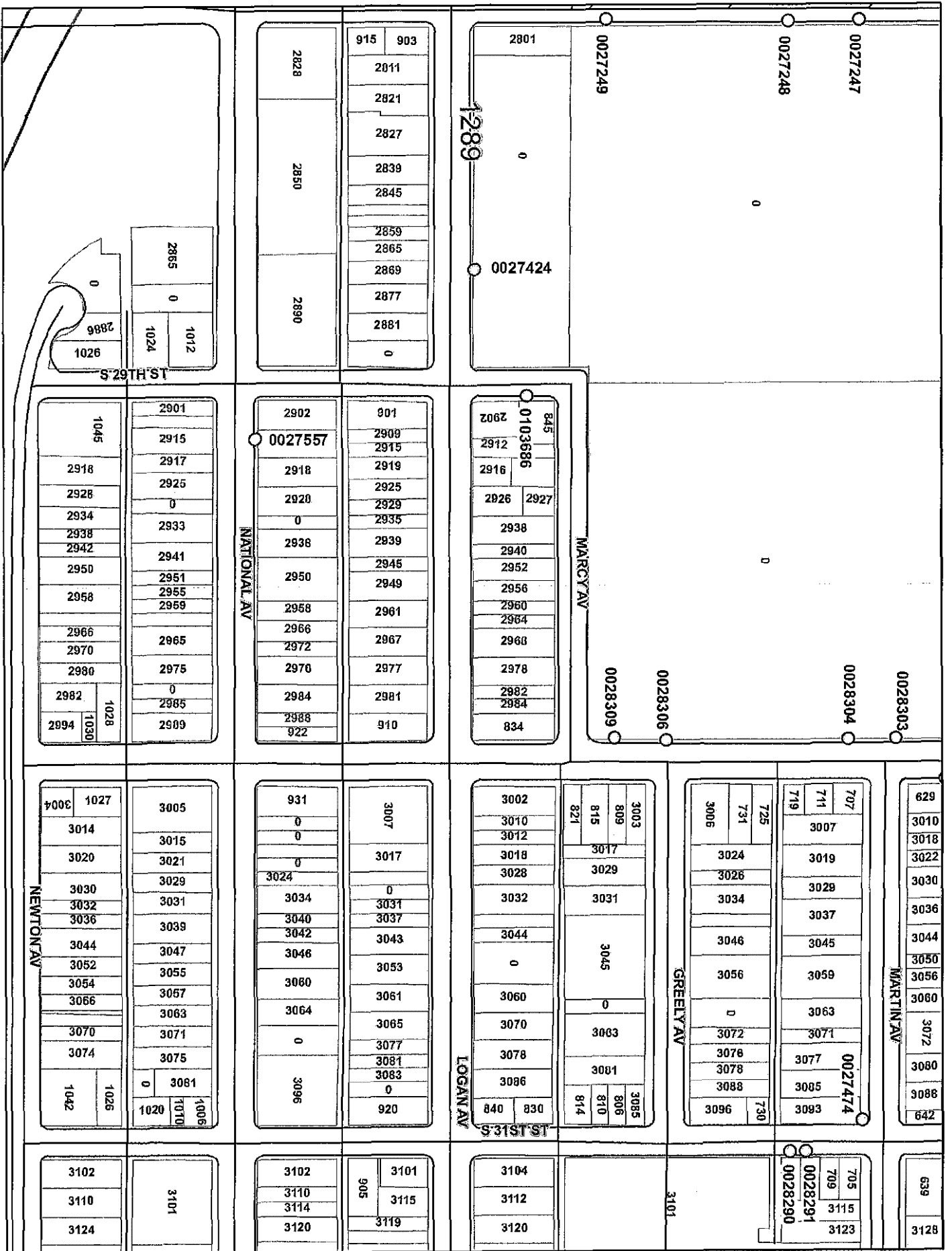







# Sidewalk Replacement Group 1601

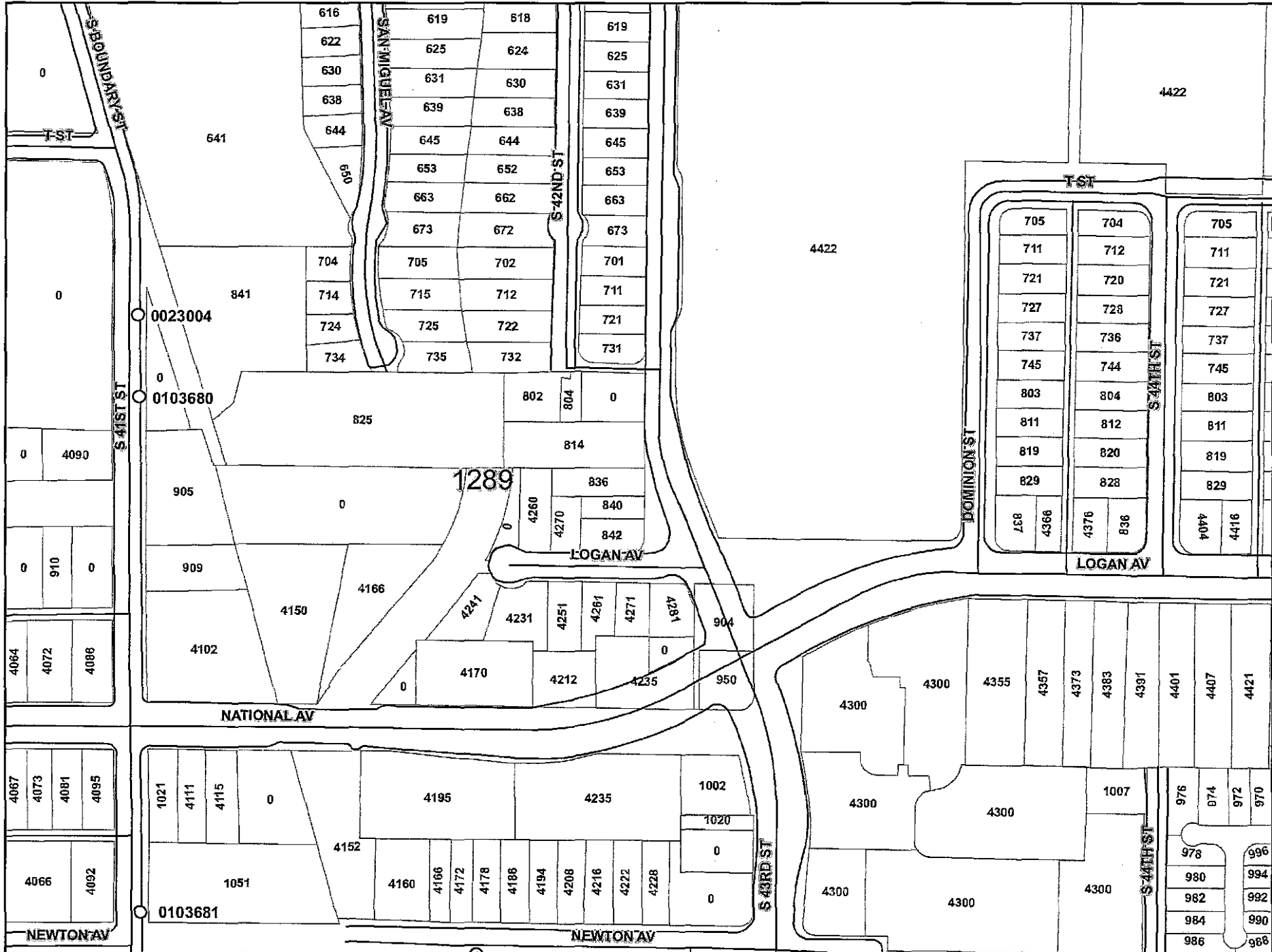

8.5x11 0 125 250 500 Feet



# Sidewalk Replacement Group 1601

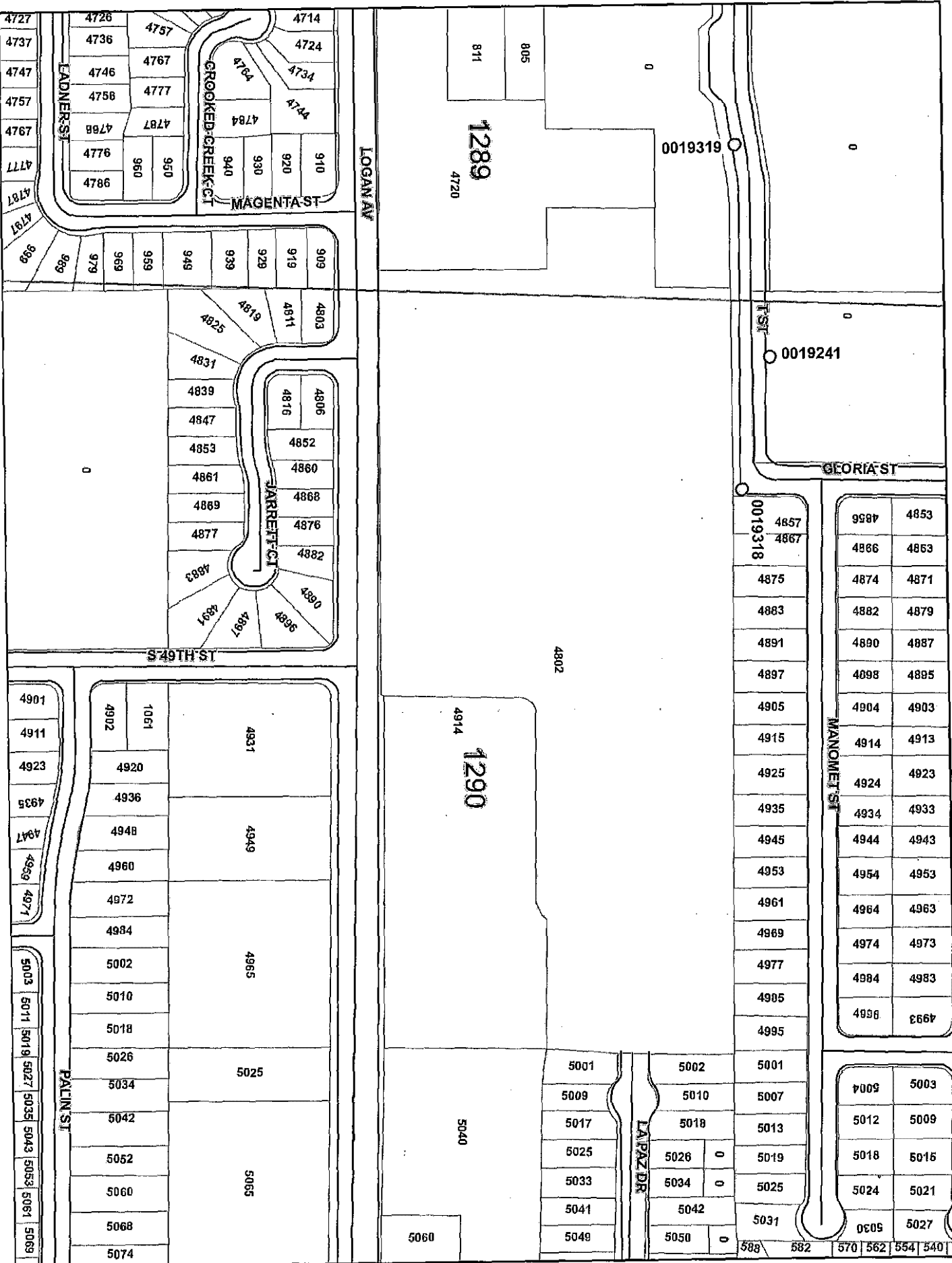

8.5x11  
 Sidewalk Replacement Group 1601 Appendix E - Location Maps (Rev. Aug. 2016)  
 0 125 250 500 Feet  
 Page 70 of 110  
 141 | Page

# Sidewalk Replacement Group 1601

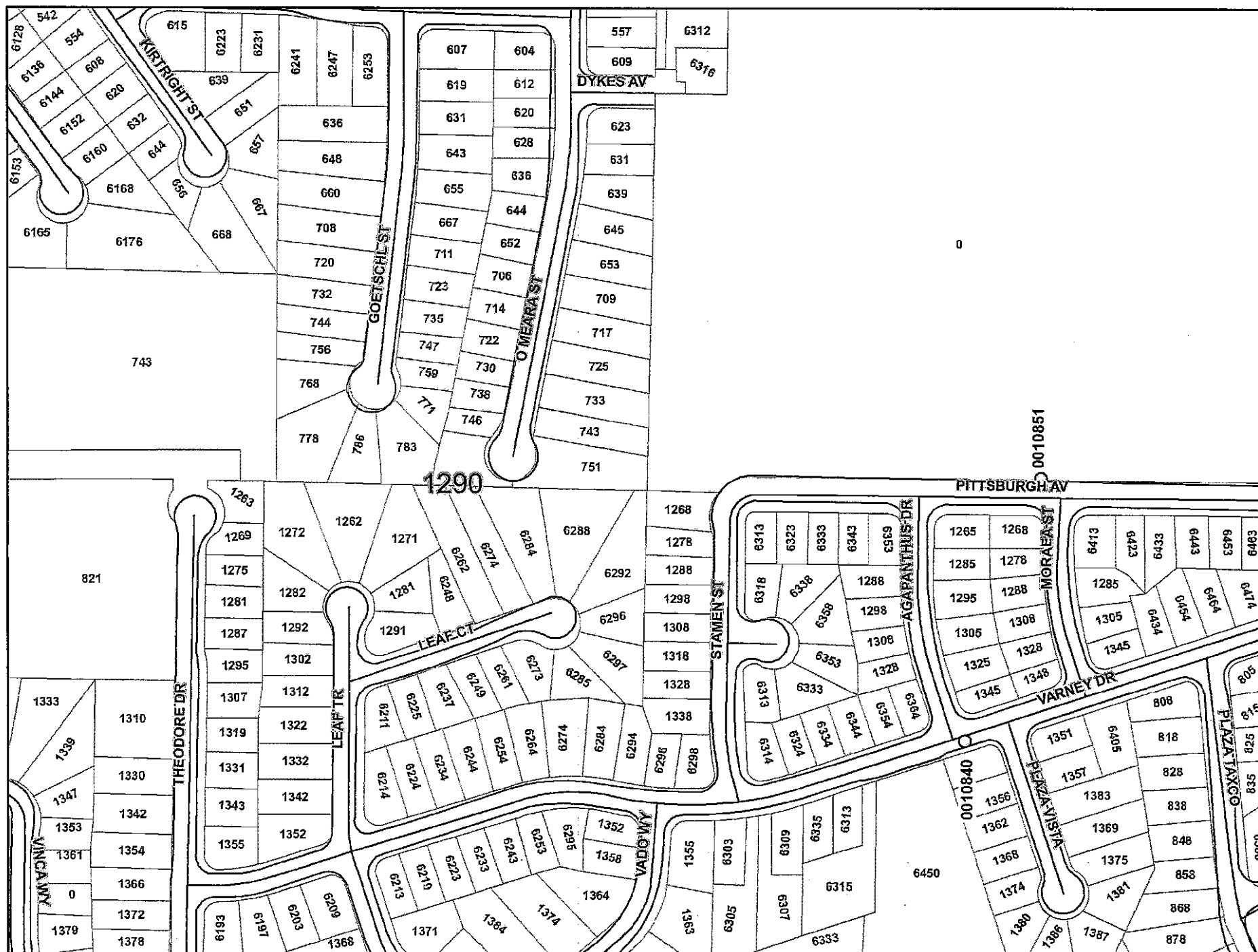

# Sidewalk Replacement Group 1601



# Sidewalk Replacement Group 1601

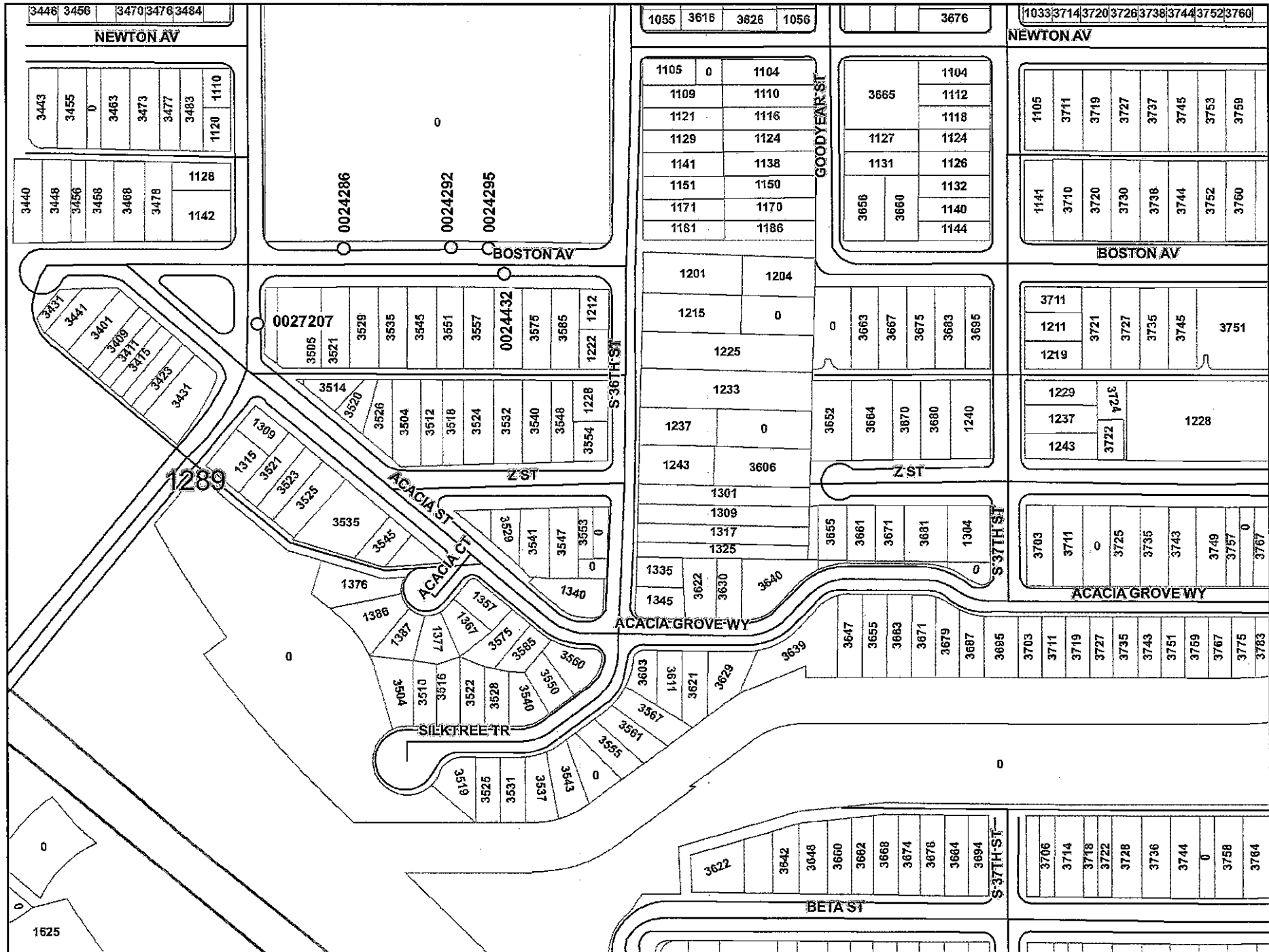











# Sidewalk Replacement Group 1601

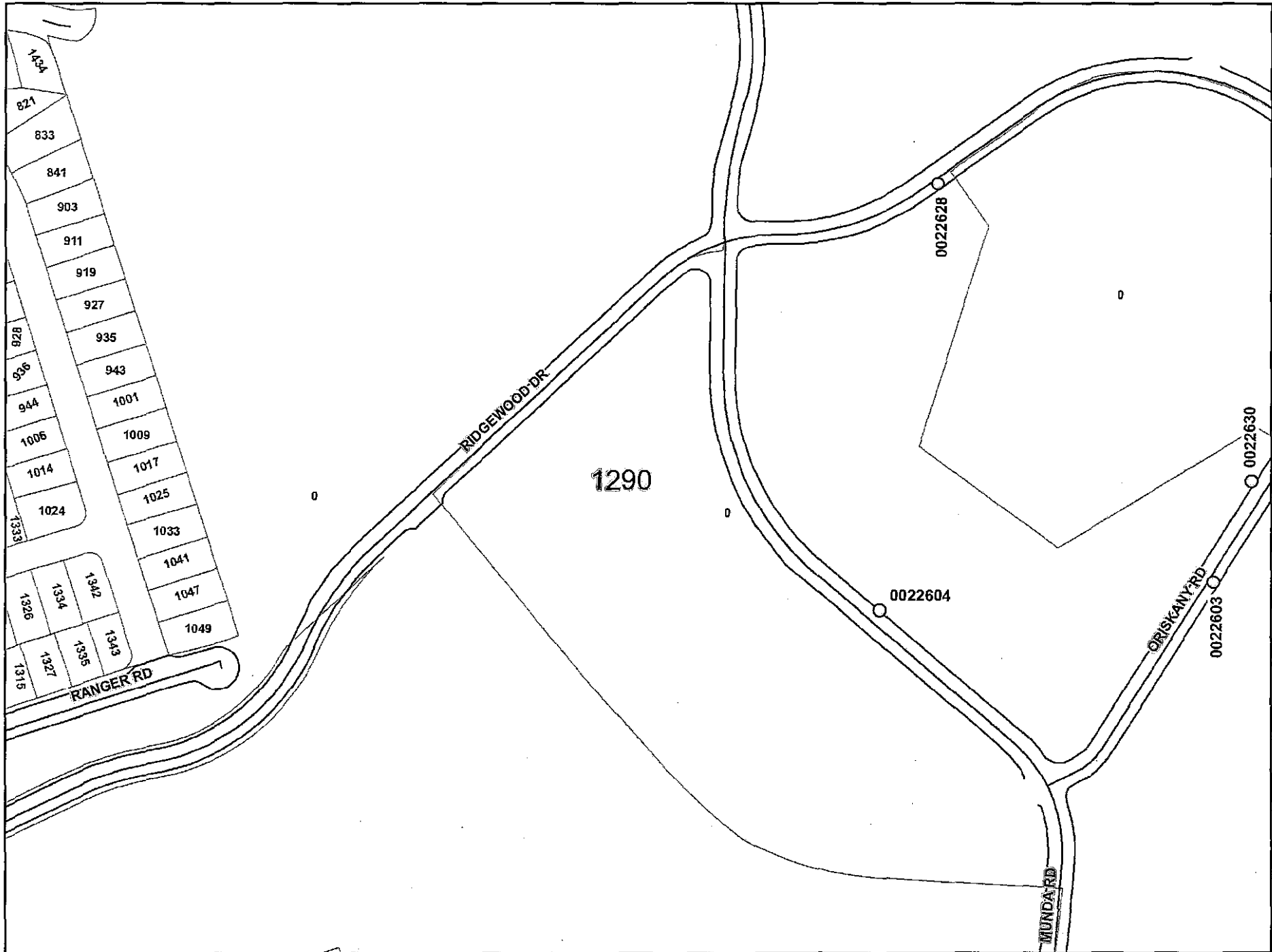

# Sidewalk Replacement Group 1601

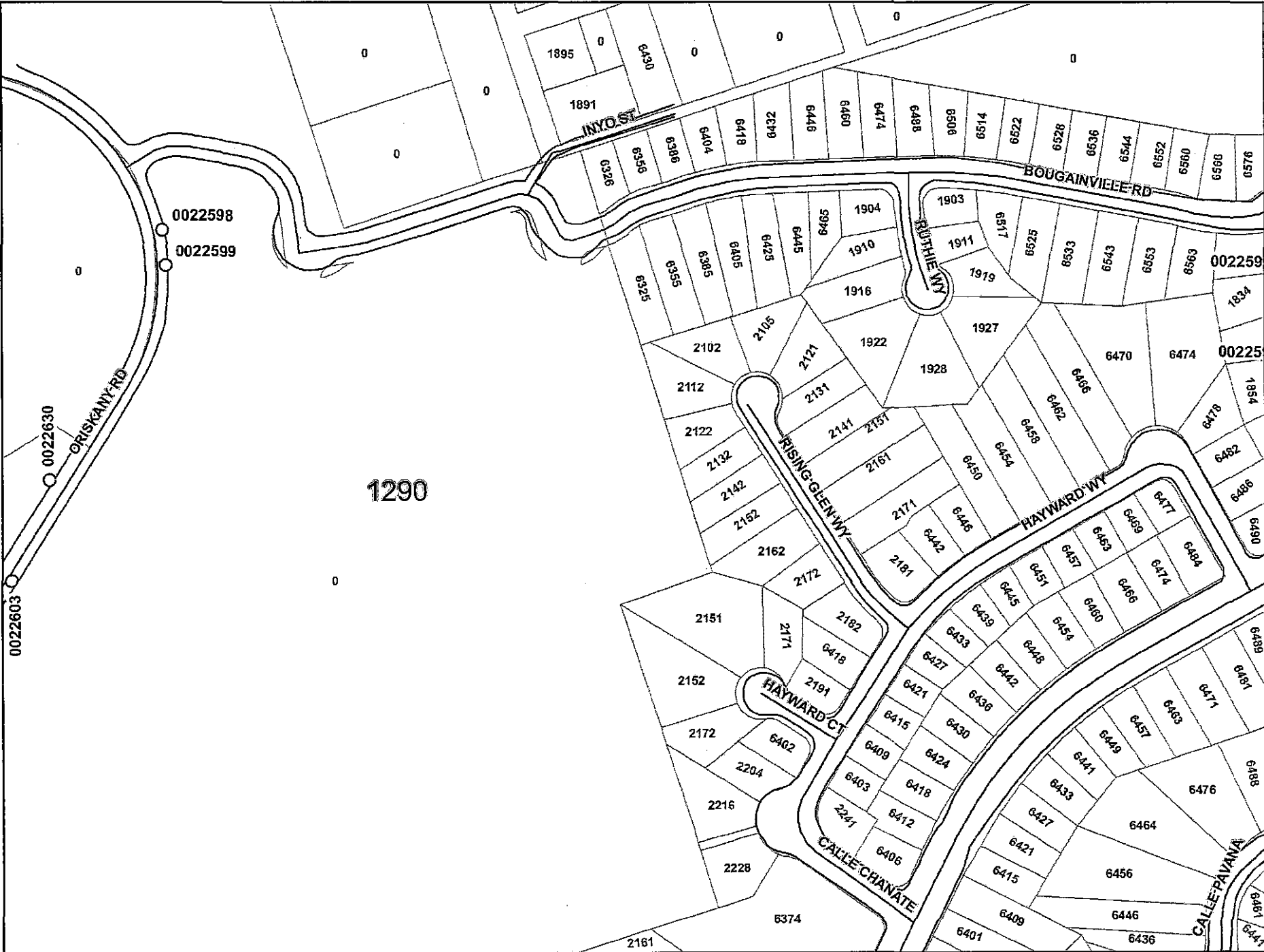

# Sidewalk Replacement Group 1601

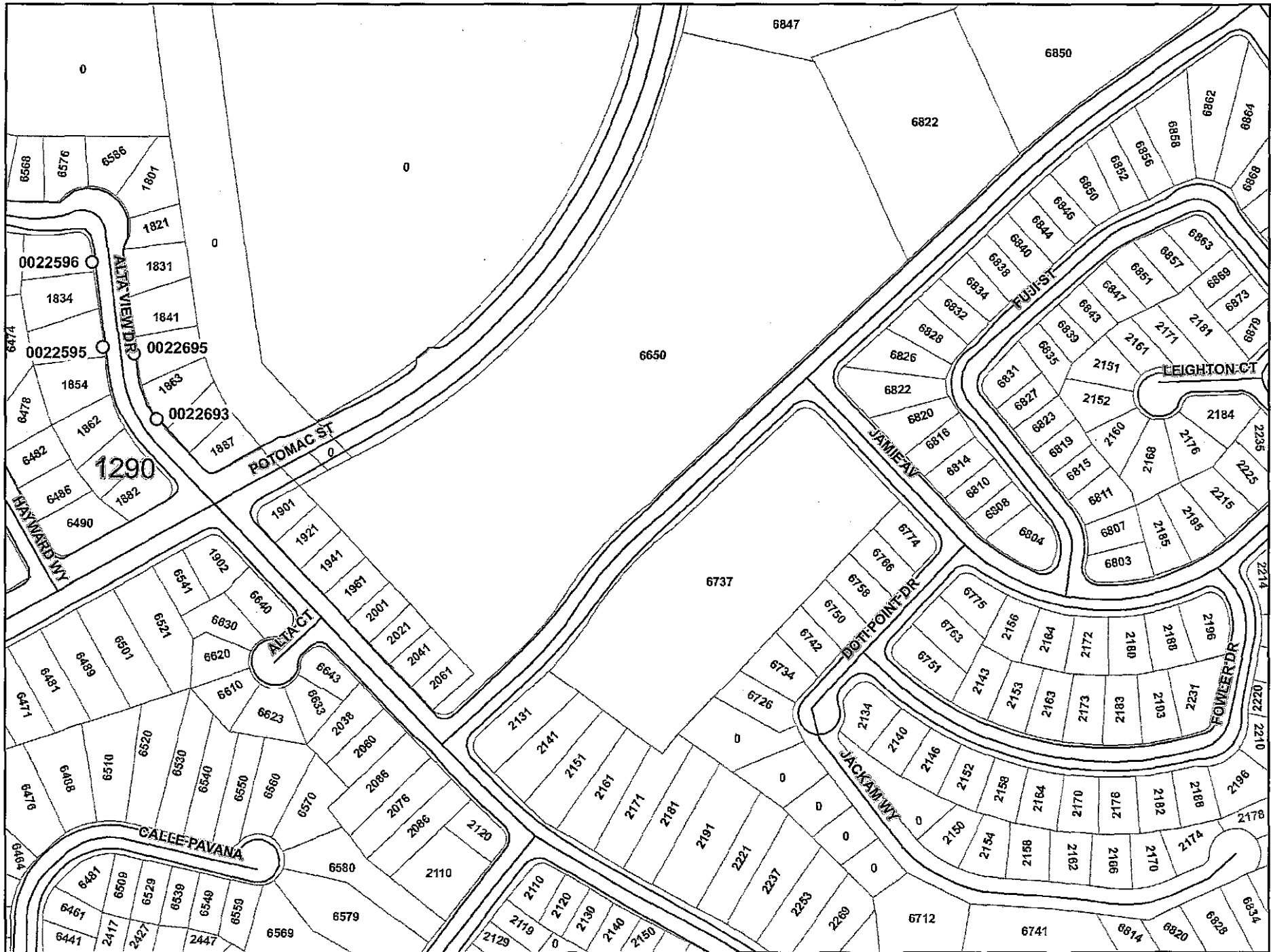



# Sidewalk Replacement Group 1601

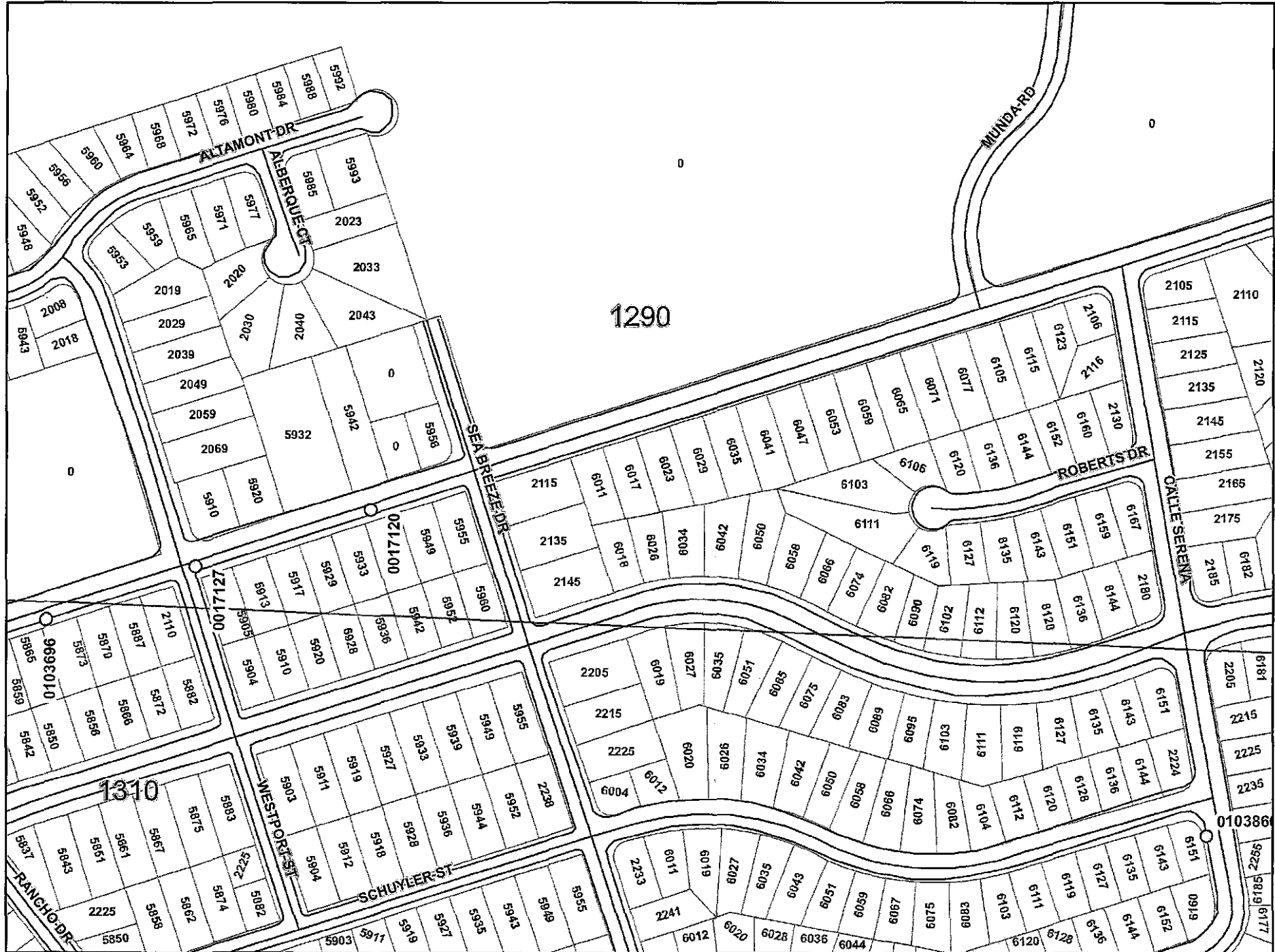

8.5x11

Sidewalk Replacement Group 1601 Appendix E - Location Maps (Rev. Aug. 2016)

0 125 250 500 Feet

Page 82 of 110

153 | Page



# Sidewalk Replacement Group 1601

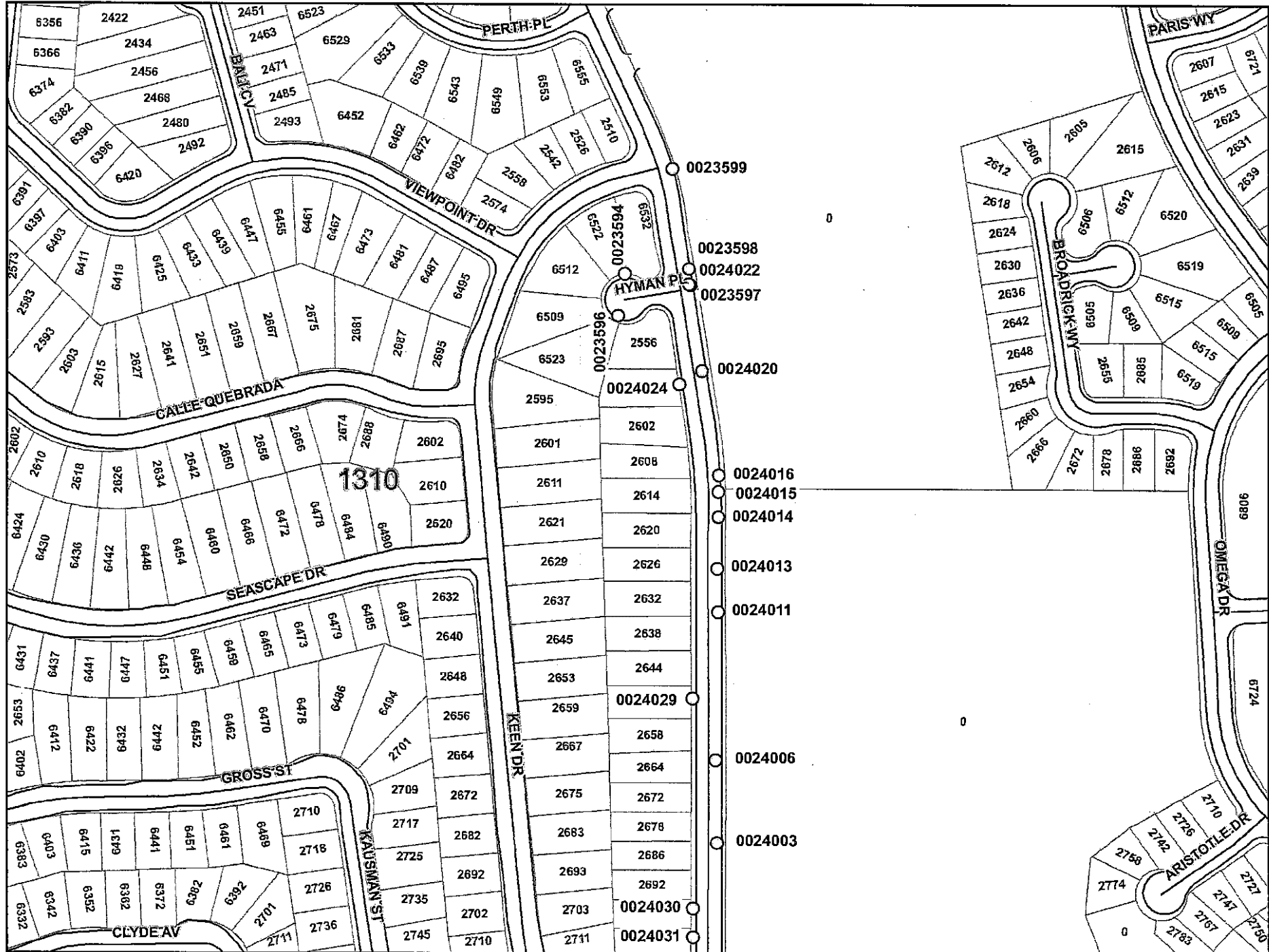



# Sidewalk Replacement Group 1601



# Sidewalk Replacement Group 1601



# Sidewalk Replacement Group 1601



8.5x11

0 125 250 500 Feet

Page 87 of 110

Sidewalk Replacement Group 1601 Appendix E - Location Maps (Rev. Aug. 2016)

158 | Page

# Sidewalk Replacement Group 1601











# Sidewalk Replacement Group 1601

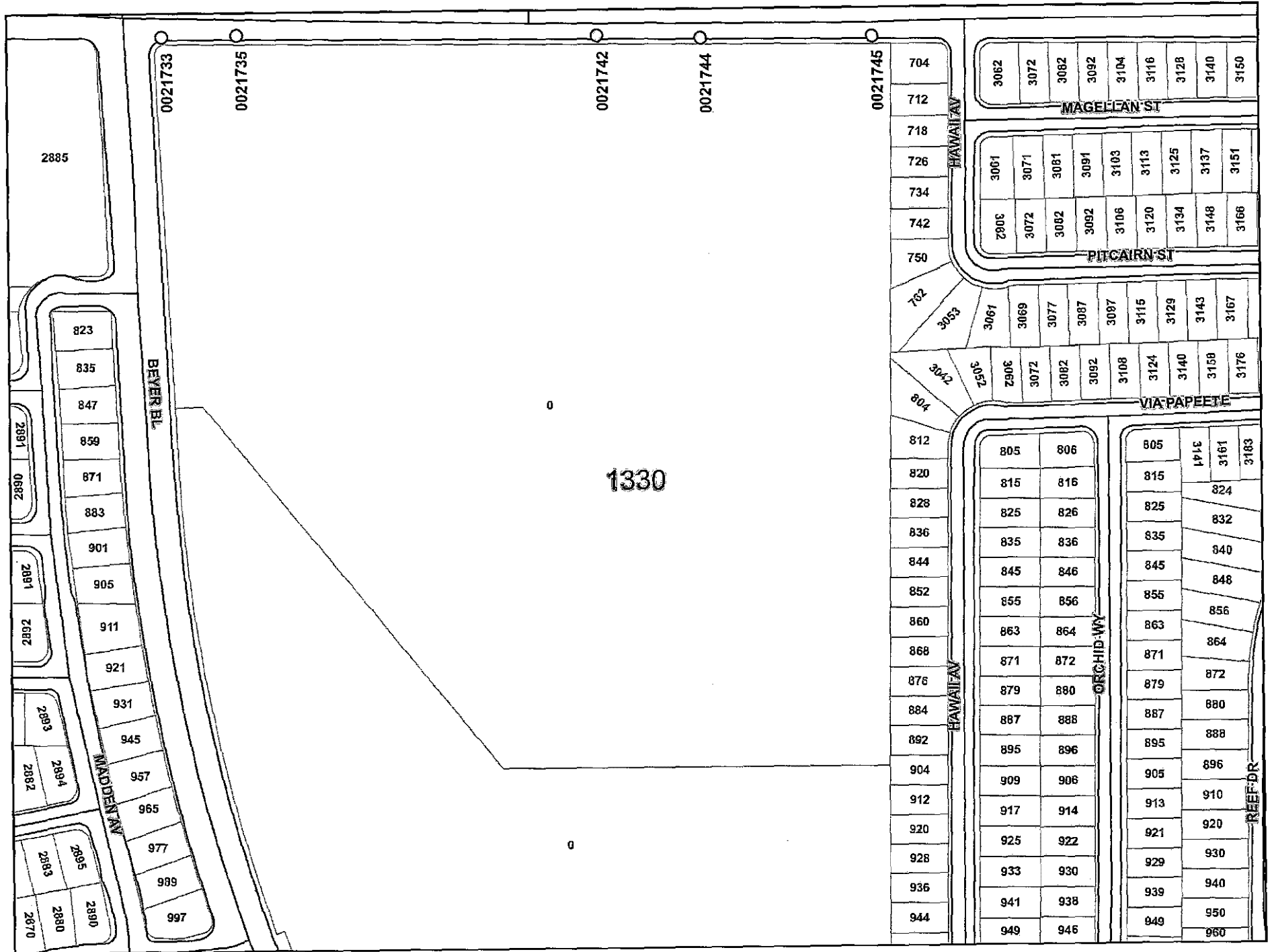

8.5x11

0 125 250 500 Feet

# Sidewalk Replacement Group 1601

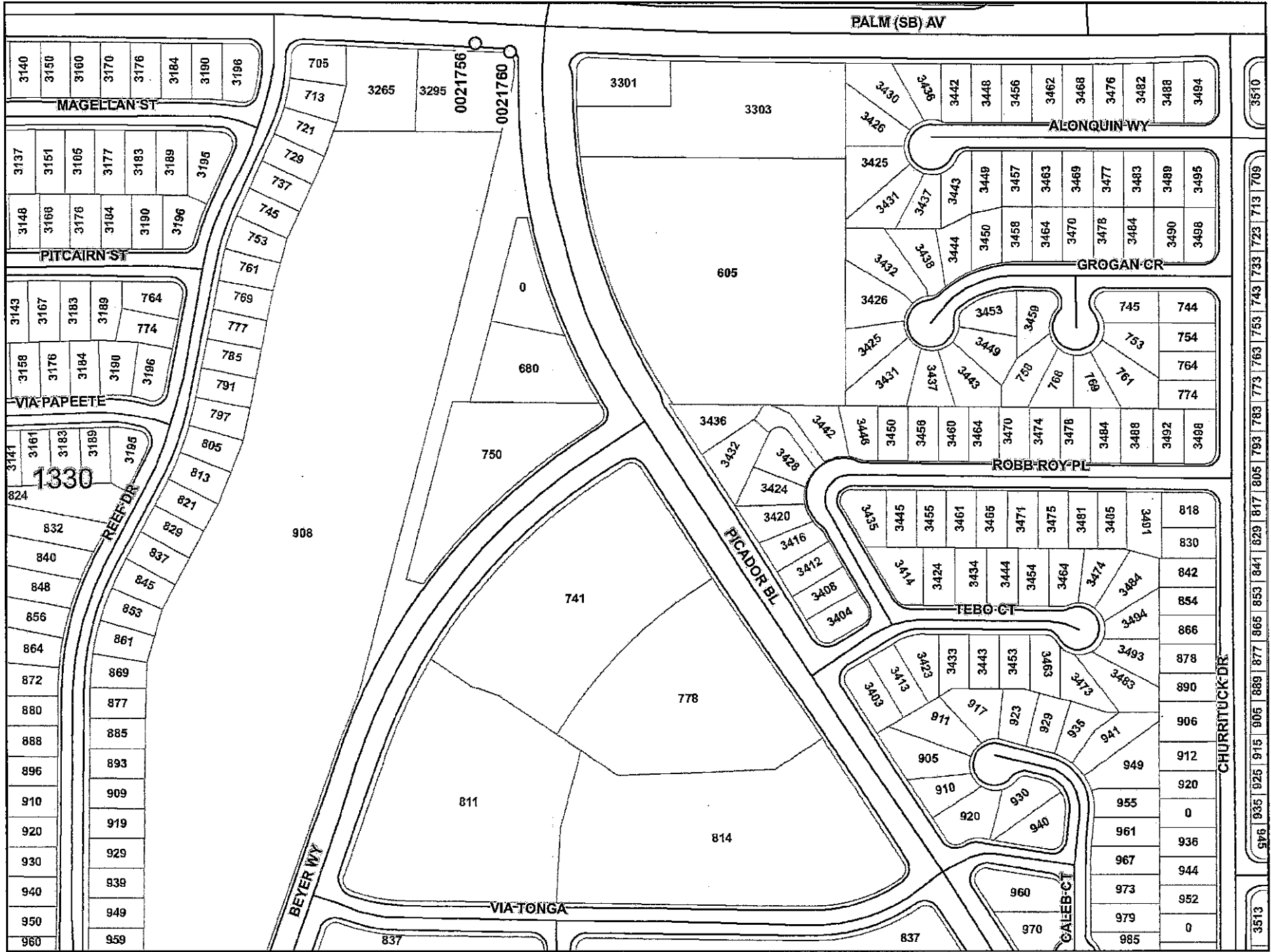

8.5x11

0 125 250 500 Feet

Page 93 of 110

# Sidewalk Replacement Group 1601





# Sidewalk Replacement Group 1601

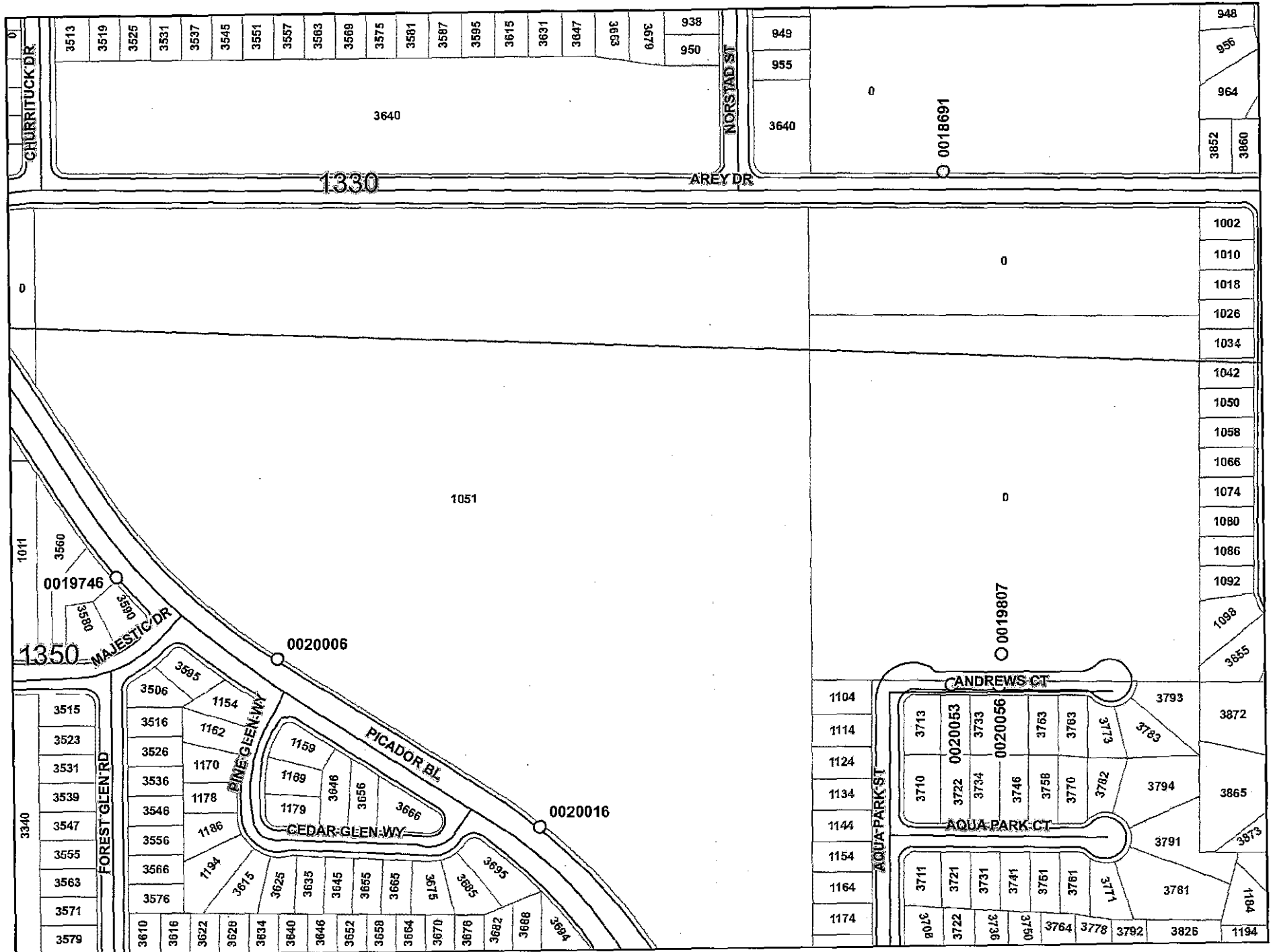

# Sidewalk Replacement Group 1601

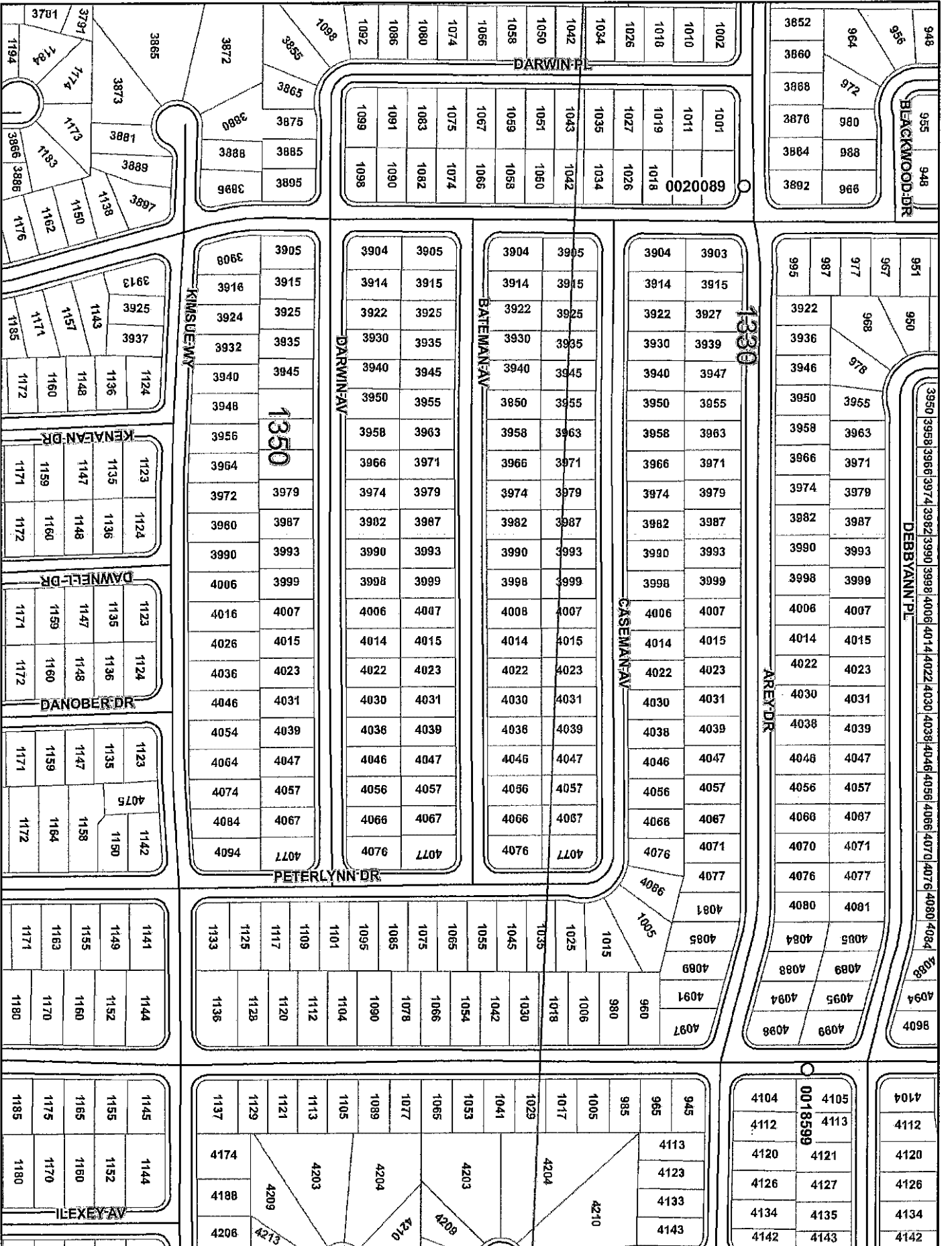

# Sidewalk Replacement Group 1601

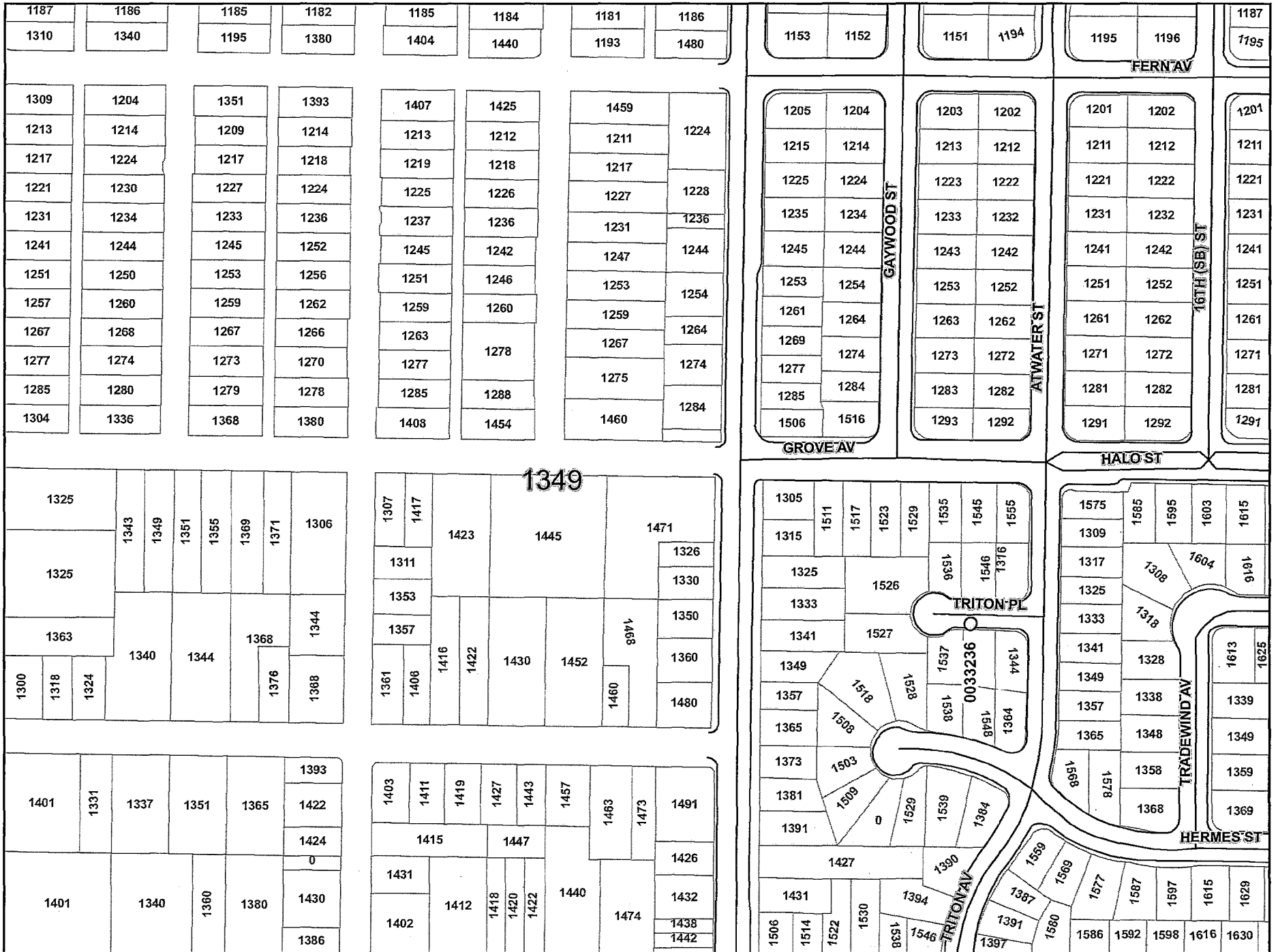



# Sidewalk Replacement Group 1601



# Sidewalk Replacement Group 1601

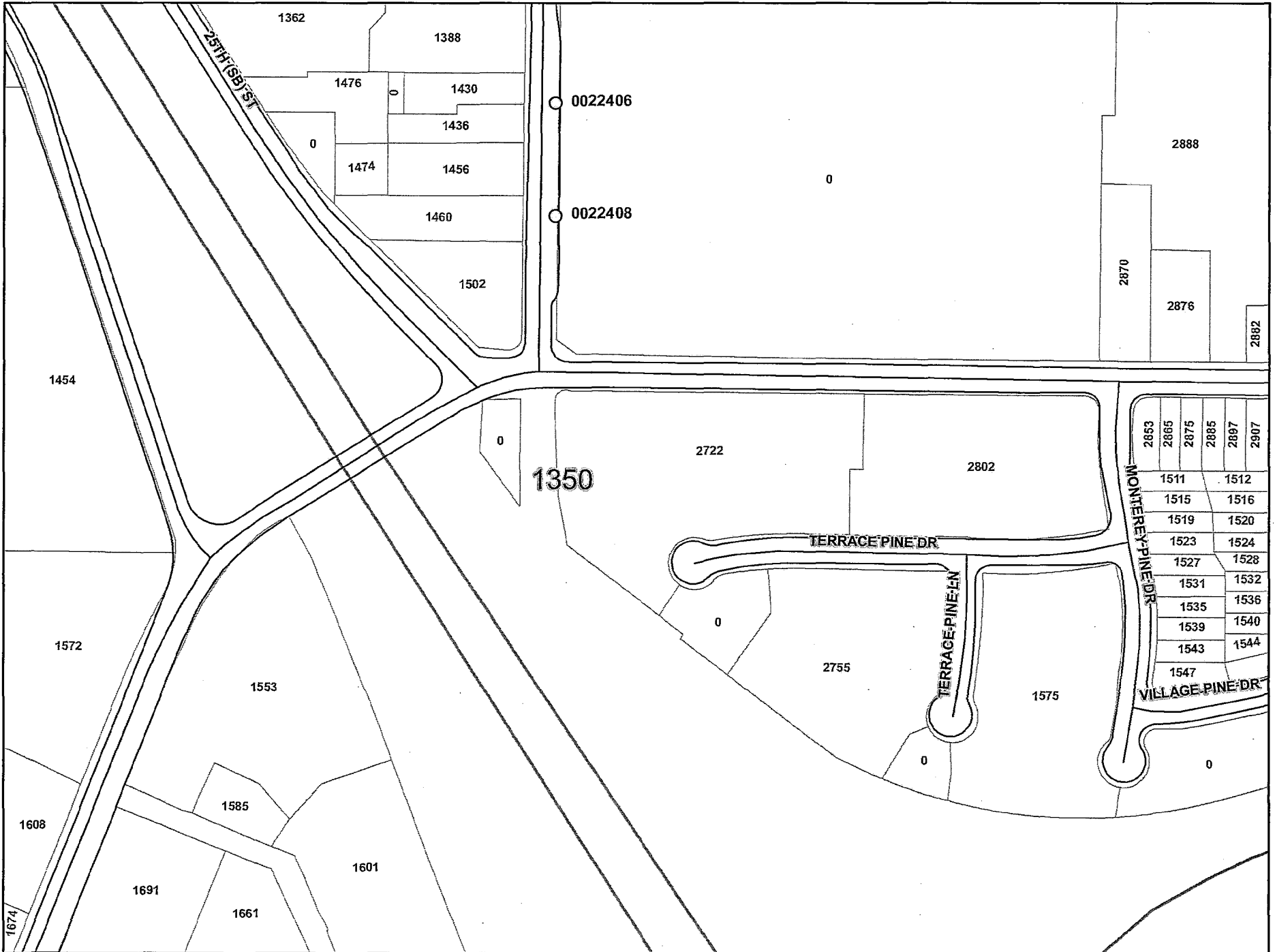

# Sidewalk Replacement Group 1601





# Sidewalk Replacement Group 1601

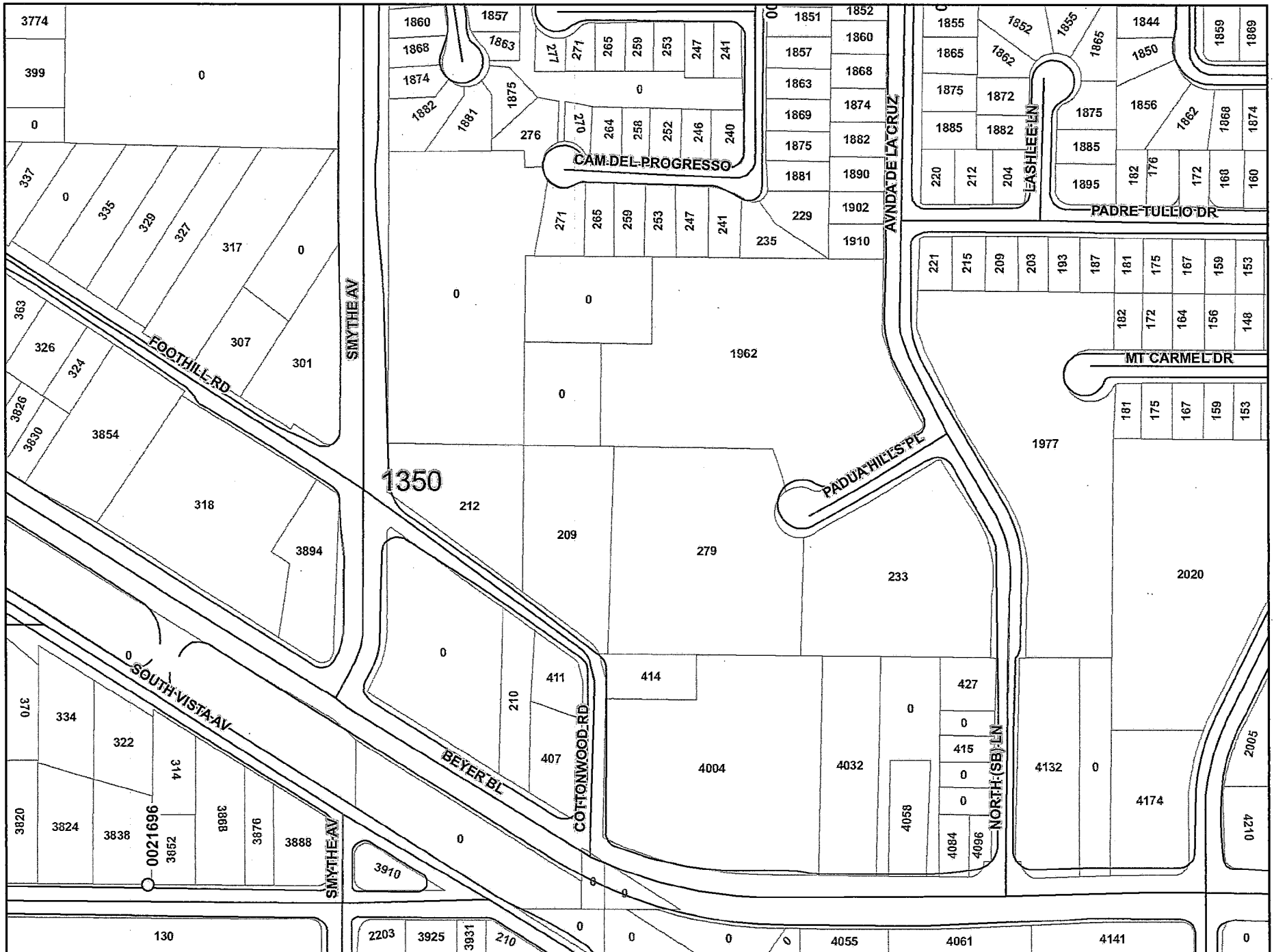



# Sidewalk Replacement Group 1601







# Sidewalk Replacement Group 1601

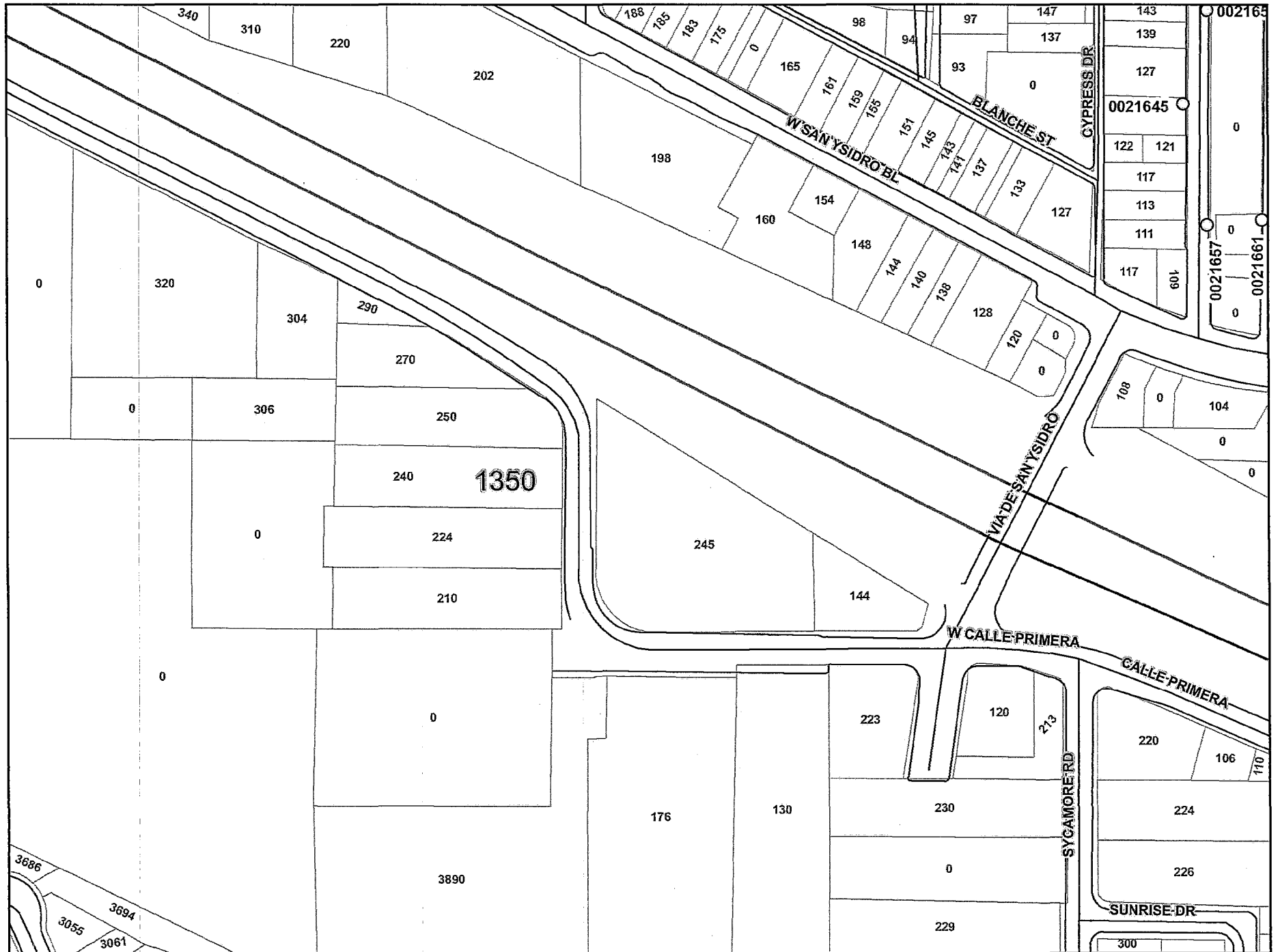



# Sidewalk Replacement Group 1601

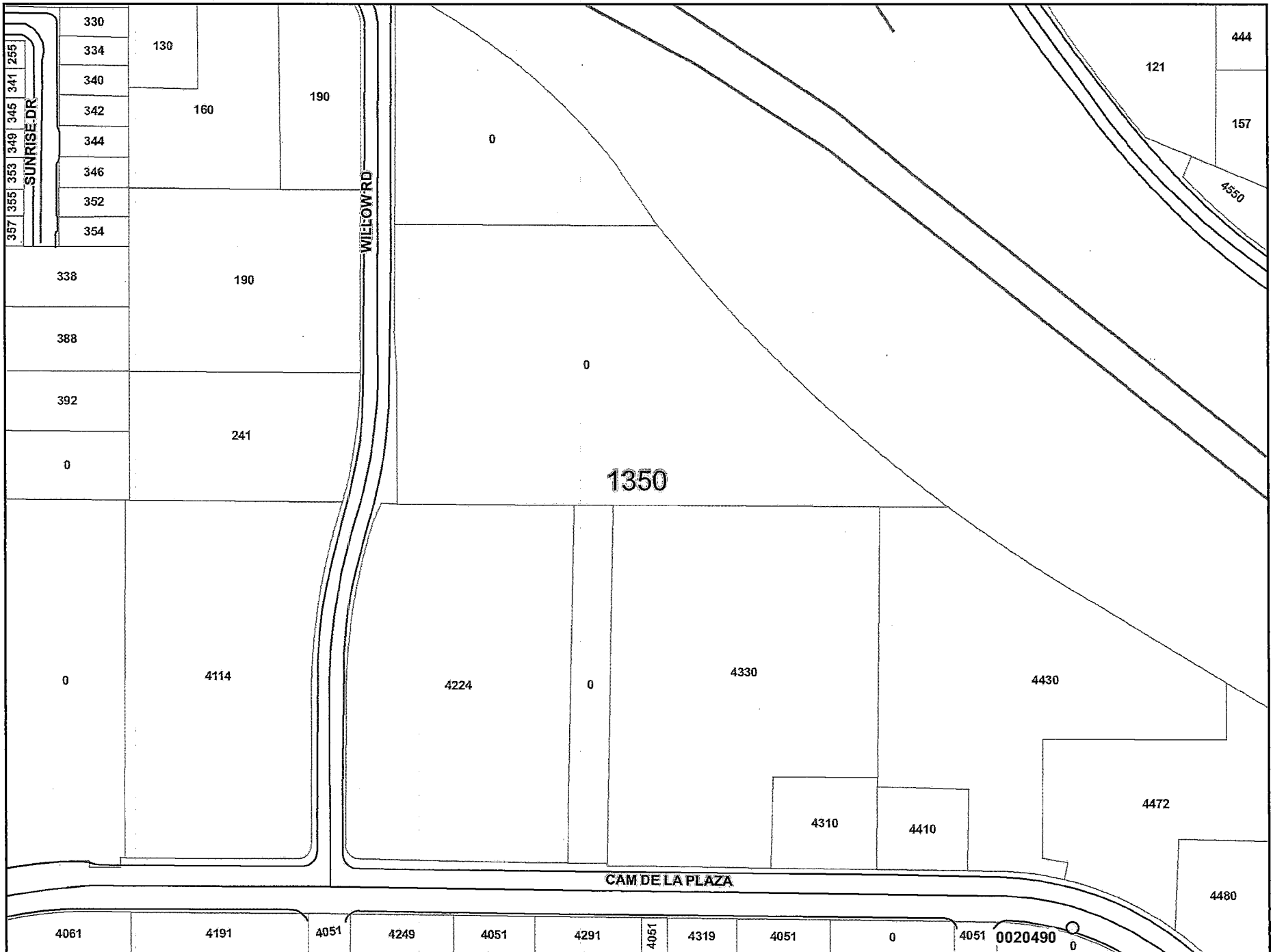

# Sidewalk Replacement Group 1601

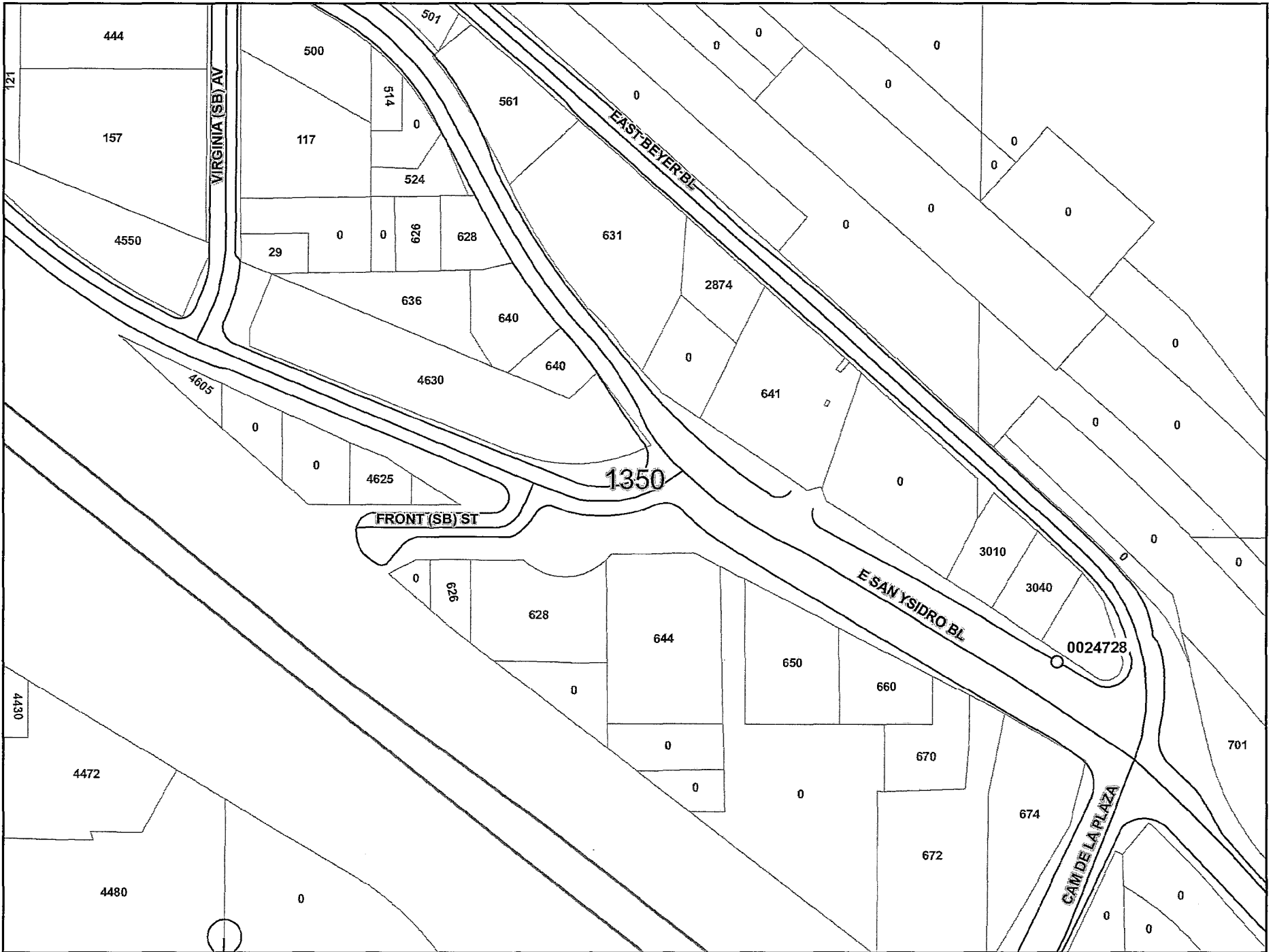

**APPENDIX F**  
**LOCATIONS LIST**

ITEM	CGID	DIST	TB	PAGE	LOCATION	Est SW SF	EST DW SF	EST CG LF	CRB RMP EA	HRD SCP	Root Barrier	Pruning	Trimming	Tree Removal	Tree Planting	Utility Box	TREE REC	CONCRETE
1	0066358	9	1270-C1	1	A/F 5500 AZTEC WALK (SDSU LOT 2A)	430					1	1					RP City Pine Tree	R&R SW 5x16, 5x70
2	0066364	9	1270-C1	1	COLLEGE AVE & SDSU CAMPUS PARKING	100					2	2					RP City Pine Tree (2)	R&R SW 5x20
3	0066365	9	1270-C1	1	COLLEGE AVE & SDSU CAMPUS PARKING (350 FT N SDSU CAMPUS PARKING)	80					1	1					RP City Tree	R&R SW 5x16
4	0103872	9	1270-D2	2	5005 LA DORNA ST	230		41						3	3		Rmv 3 Ash trees, Repl with 3 Raywood Ash	R&R SW 4x20, 5x30, CG 26 LF
5	0062427	9	1270-D2	3	4860 CATOCTIN DR	248												R&R SW 4x62
6	0062430	9	1270-D2	3	4860 CATOCTIN DR			62										R&R CG 62 LF
7	0062433	9	1270-D2	3	A/F 4959 CATOCTIN DR	250					1	1					RP City Tree	R&R SW 5x50
8	0068658	9	1269-J3	4	4588 EUCLID AVE	234					2	2					RP City Tree (2)	R&R SW 3x12, 6x33
9	0068660	9	1269-J4	4	4562 EUCLID AV	234					2	2					RP City Tree (2)	R&R SW 6x18, 3x9, 15x6, 3x3
10	0063477	9	1270-D3	5	4534 ARAGON DR	366					1	1		5	4		Rmv (2) Jac. (2) Bra. Pep. (1) Q.Palm Stump, Repl with (2) Crape Myrtle (2) Gold Medalion Trees	R&R SW 5x55, 6x11, 5x5
11	0071783	9	1269-H4	6	A/F 4490 HIGHLAND AV	68												R&R SW 4x17
12	0071793	9	1269-H4	6	4396 HIGHLAND AVE	75												R&R SW 5x15
13	0064731	9	1269-J4	6	4387 46TH ST	48												R& SW 4x12
14	0071776	9	1269-H4	6	A/F 4416 HIGHLAND AVE	24												R&R SW 4x6
15	0103873	9	1270-D4	7	6459 MALCOLM DR	100		16										R&R SW 5x20, CG 16 LF
16	0070136	9	1269-F5	8	3471 POLK AVE	60												R&R SW 5x12
17	0070137	9	1269-F5	8	4096 35TH ST (ON POLK AVE)	85		17										R&R SW 5x17, CG 17 LF
18	0070145	9	1269-F5	8	3353 POLK AVE	60												R&R SW 10x6
19	0070474	9	1269-G4	8	3676 ORANGE AVE	125					2	2					RP City Tree (2)	R&R SW 5x25
20	0070487	9	1269-G4	9	4252 37TH ST	822												R&R SW 6x137
21	0070959	9	1269-G4	9	A/F 3762 EL CAJON BL	765												R&R SW 10x74, 5x5
22	0070527	9	1269-G4	9	4263 39TH ST	270	12											R&R SW 5x54, DW 12x5
23	0070528	9	1269-G4	9	4259 39TH ST	120												R&R SW 5x24
24	0070529	9	1269-G4	9	4251 39TH ST	270												R&R SW 5x54
25	0070530	9	1269-G4	9	4241 39TH ST	150												R&R SW 5x30
26	0070957	9	1269-G4	9	3773 EL CAJON BL	84												R&R SW 7x12
27	0070467	9	1269-G5	9	3677 ORANGE AVE	275					1	1					RP City Tree	R&R SW 5x55
28	0070475	9	1269-G5	9	ORANGE AVE AND 37TH ST	250					1	1					RP City Tree	R&R SW 5x50
29	0070476	9	1269-G4	9	4222 37TH ST	140					2	2					RP City Tree (2)	R&R SW 5x28
30	0070510	9	1269-G5	9	3700 ORANGE AVE (ORANGE & 37TH)	120												R&R SW 4x30









131	0013692	4	1290-D3	38	6373 BROADWAY	12														1		R&R SW 4x3, Repl City Utility Box
132	0013689	4	1290-D3	39	SOUTHWEST CORNER OF BROADWAY & 65TH	70			1													R&R SW 5x14, Rmv and Repl Crb Rmp Type A
133	0013987	4	1290-D3	39	927 63RD ST	104																R&R SW 5x19, 3x3
134	0013978	4	1290-D3	39	819 65TH ST	60															1	R&R SW 4x15, Repl City Utility Box
135	0013983	4	1290-D3	39	65TH ST & WUNDERLIN AVE	32																R&R SW 3x4, 4x5
136	0013985	4	1290-D3	39	822 65TH ST	104																R&R SW 5x19, 3x3
137	0014514	4	1290-E2	39	6581 BROADWAY	40																R&R SW 4x10
138	0014914	4	1290-E2	39	6501 BROADWAY	88															1	R&R SW 8x11, Repl City Utility Box
139	0013984	4	1290-D3	39	65TH ST & WUNDERLIN AVE	20																R&R SW 4x5
140	0029833	8	1289-C4	40	2262 ISLAND AV	85					1	1										RP City Tree R&R SW 5x17
141	0029070	8	1289-C4	40	404 22ND ST	110					1	1										RP City Tree R&R SW 5x22
142	0029184	8	1289-D4	41	409 27TH ST	119																R&R SW 7x17
143	0103689	8	1289-D4	41	A/F 458 26TH ST	50					1	1										RP City Tree R&R SW 5x10
144	0029185	8	1289-D4	41	425 27TH ST	216	40															R&R SW 6x36, DW 10x4
145	0029186	8	1289-D4	41	441 27TH ST		40															R&R DW 10x4
146	0029708	8	1289-D4	41	A/F 446 26TH ST	25																R&R SW 5x5
147	0029193	8	1289-D4	41	A/F 2663 J ST	280																R&R SW 8x35
148	0029198	8	1289-D4	41	A/F 2605 J ST	165																R&R SW 5x33
149	0029710	8	1289-D4	41	446 26TH ST	125																R&R SW 5x25
150	0029199	8	1289-D4	41	A/F 2585 J ST	72																R&R SW 6x12
151	0029213	8	1289-D4	41	2629 J ST	120				20												R&R SW 6x20, Rmv Hrd Scp 2x10
152	0029219	8	1289-D4	41	2695 J ST	75					1	1										RP City Tree R&R SW 5x15
153	0029180	8	1289-D4	41	331 27TH ST	90	15											1	3	1		Rmv Date Palm, Plant (3) Crape Myrtle R&R SW 6x15, CG 15 LF, Repl City Utility Box
154	0029181	8	1289-D4	41	351 27TH ST	132																R&R SW 6x22
155	0029177	8	1289-D4	41	2704 K ST	60																R&R SW 6x10
156	0028889	8	1289-D4	41	2704 K ST	210	15															R&R SW 6x35, CG 15 LF
157	0026780	8	1289-E4	42	A/F 321 DODSON ST	175					1	1										RP City Tree R&R SW 35x5
158	0026782	8	1289-E4	42	A/F 355 DODSON ST	75					1	1										RP City Tree R&R SW 15x5
159	0026784	8	1289-E4	42	A/F 355 DODSON ST	50					1	1										RP City Tree R&R SW 10x5
160	0005414	9	1289-H3	43	628 RAVEN ST	90					1	1					1	1				Rmv (1) Carrotwood, Repl with (1) Crape Myrtle Tree R&R SW 5x18
161	0005413	9	1289-H3	43	622 RAVEN ST	66					1	1										RP City Tree R&R SW 12x5.5
162	0005525	9	1289-G3	43	A/F 629 BOUNDARY ST	24																R&R SW 4x6
163	0008806	9	1289-G3	43	610 GATEWAY CENTER WY (@MARKET ST)	136.5					1	1										RP City Tree R&R SW 2.5x15, 15x5, 6x4
164	0006612	4	1289-J3	44	A/F 4588 MARKET ST	48															1	R&R SW 6x8, Repl City Utility Box
165	0006614	4	1289-J3	44	A/F 4588 MARKET ST	55															1	R&R SW 5x11, Repl City Utility Box

166	0006616	4	1289-J3	44	A/F 4588 MARKET ST	30												1	R&R SW 5x6, Repl City Utility Box
167	0006622	4	1289-J3	44	A/F 4588 MARKET ST	30													R&R SW 5x6
168	0006623	4	1289-J3	44	A/F 4588 MARKET ST	55												1	R&R SW 5x11, Repl City Utility Box
169	0006625	4	1289-J3	44	A/F 4538 MARKET ST	400													R&R SW 10x40
170	0015440	4	1290-E3	45	A/F 6744 AKINS AVE ON IMPERIAL AVE (ENCANTO PARK)	200								1	1				Rmv (1) City Tree, Replace with 1 Raywood Ash Tree
171	0015559	4	1290-E3	45	INTERSECTION OF WOODMAN ST AND IMPERIAL AV	420		11											R&R SW 5x84, CG 11 LF
172	0103867	8	1289-D4	46	2445 IMPERIAL AV	168			44	1	1							1	RP City Tree
173	0028996	8	1289-D4	46	2430 COMMERCIAL ST	96													R&R SW 16x6
174	0103868	8	1289-D4	47	2589 IMPERIAL AV	480			72	3	3								R&R SW 10x32, 10x16, Rmv Hrd Scp 18x4
175	0028968	8	1289-D4	47	2710 IMPERIAL AV	80		13	68	1	1								R&R SW 5x16, Rmv Hrd Scp 13x4, 4x4, CG 13 LF
176	0027076	8	1289-E4	48	3050 IMPERIAL AV	120			190	1	1								R&R SW 5x24, Rmv Hrd Scp 38x5
177	0027077	8	1289-E4	48	3018 IMPERIAL AV	144			56	7	7			1					Rmv Chinese Tallow, RP and Enlarge Planter (7)
178	0103869	8	1289-E4	48	3040 L ST	270				1	1			2	2				Rmv City Tree, Tipu (2), Plant (2) Gold Medallion
179	0103870	8	1289-E4	48	2866 IMPERIAL AV			14	32	1	1								RP City Tree
180	0027086	8	1289-E4	48	2874 IMPERIAL AV	120			1	48	1	1							R&R SW 24x5, Rmv Hrd Scp 12x4, R&R Crb Rmp (A), Repl City Utly Box
181	0019364	4	1289-J4	49	4704 IMPERIAL AV	18													R&R SW 3x6, Traffic Signal Box
182	0018522	4	1289-J4	49	4704 IMPERIAL AV (ON ESCUELA ST)	150				1	1								RP City Tree
183	0019361	4	1290-A4	49	4758 IMPERIAL AV	40												1	R&R SW 4x10, Repl City Utility Box
184	0019301	4	1290-A4	49	4910 IMPERIAL AV	70													R&R SW 5x14
185	0012993	4	1290-C4	50	160 61ST ST	140													R&R SW 28x5
186	0012994	4	1290-C4	50	150 61ST ST	80													R&R SW 16X5
187	0007232	4	1290-G4	51	201 LAUSANNE DR	150			50										R&R SW 30x5
188	0016657	4	1290-H4	52	228 MIDDLEBUSH DR	88								1	1				Rmv 1 City Tree, Repl with 1 Gold Medallion Tree
189	0016871	4	1290-H4	52	311 SAWTELLE AV	144													R&R SW 24x6
190	0016970	4	1290-H4	53	305 ENCINITAS AV	45													R&R SW 15X3
191	0016781	4	1290-H4	53	BETWEEN SAWTELLE AV AND SUNNYSIDE AV	225				1	1								RP City Tree
192	0016782	4	1290-H4	53	BETWEEN SAWTELLE AV AND SUNNYSIDE AV	50				1	1								RP City Tree
193	0016783	4	1290-H4	53	BETWEEN ENCINITAS AV AND SUNNYSIDE AV	50													R&R SW 5x10
194	0016784	4	1290-H4	53	BETWEEN ENCINITAS AV AND SUNNYSIDE AV	75													R&R SW 5x5, 5x4, 5x6

















**APPENDIX G**  
**TREE RELATED DRAWING DETAILS**

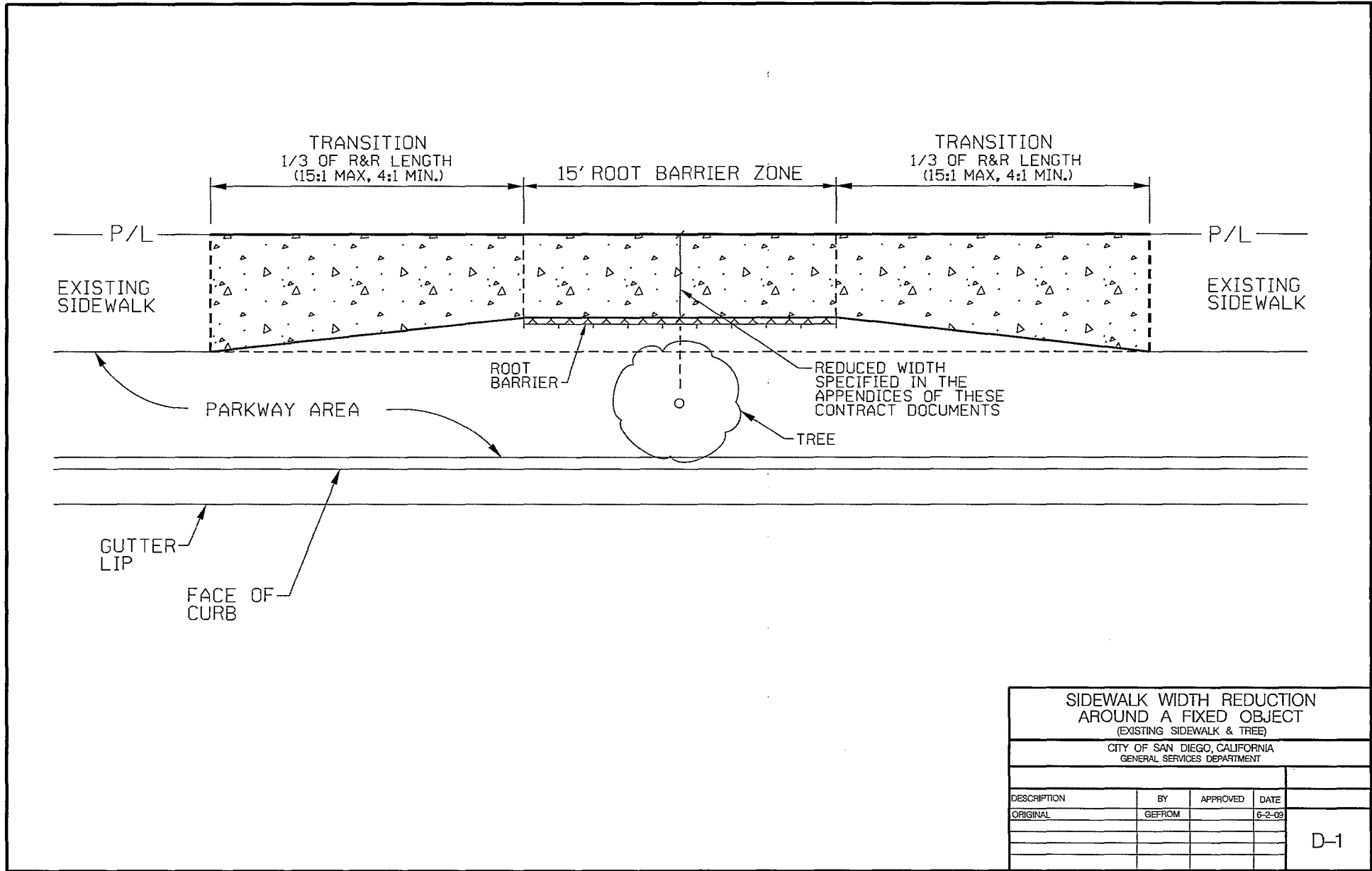

SIDEWALK WIDTH REDUCTION AROUND A FIXED OBJECT (EXISTING SIDEWALK & TREE)				
CITY OF SAN DIEGO, CALIFORNIA GENERAL SERVICES DEPARTMENT				
DESCRIPTION	BY	APPROVED	DATE	
ORIGINAL	GEFROM		8-2-09	D-1

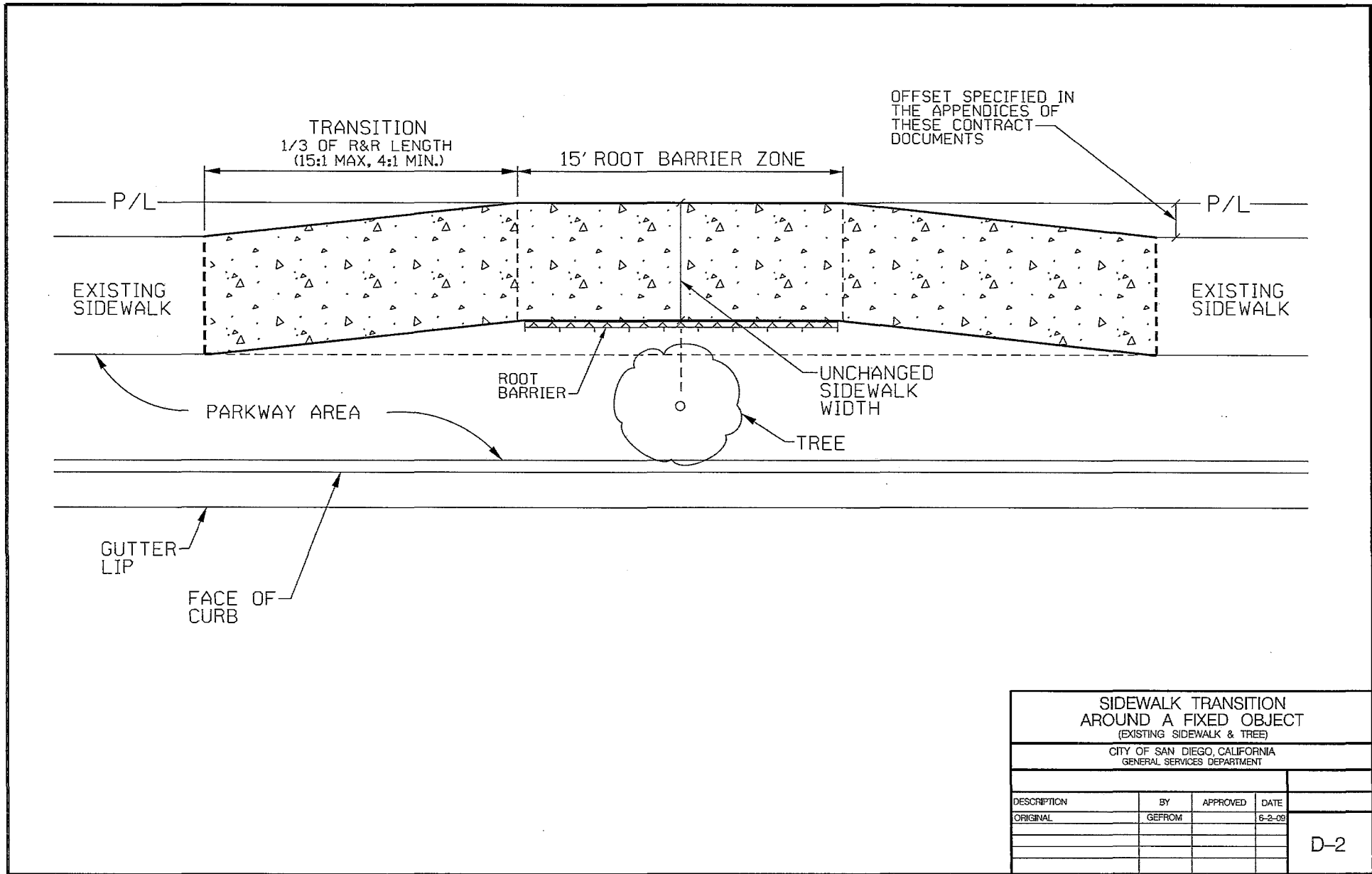

SIDEWALK TRANSITION AROUND A FIXED OBJECT (EXISTING SIDEWALK & TREE)			
CITY OF SAN DIEGO, CALIFORNIA GENERAL SERVICES DEPARTMENT			
DESCRIPTION	BY	APPROVED	DATE
ORIGINAL	GEFROM		6-2-09

D-2

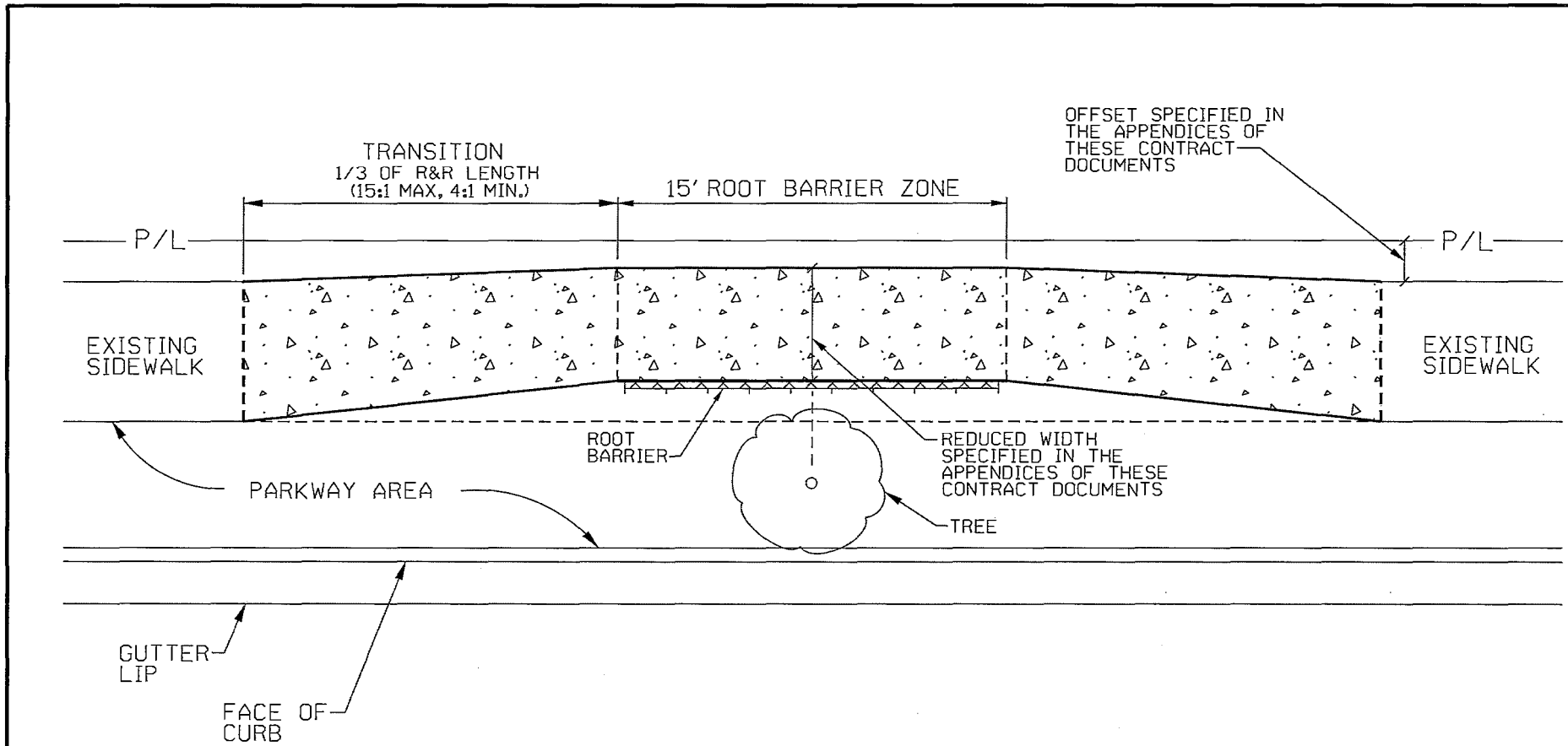

SIDEWALK WIDTH REDUCTION AND TRANSITION AROUND A FIXED OBJECT (EXISTING SIDEWALK & TREE)				
CITY OF SAN DIEGO, CALIFORNIA GENERAL SERVICES DEPARTMENT				
DESCRIPTION	BY	APPROVED	DATE	
ORIGINAL	GEFROM		6-2-09	

D-3

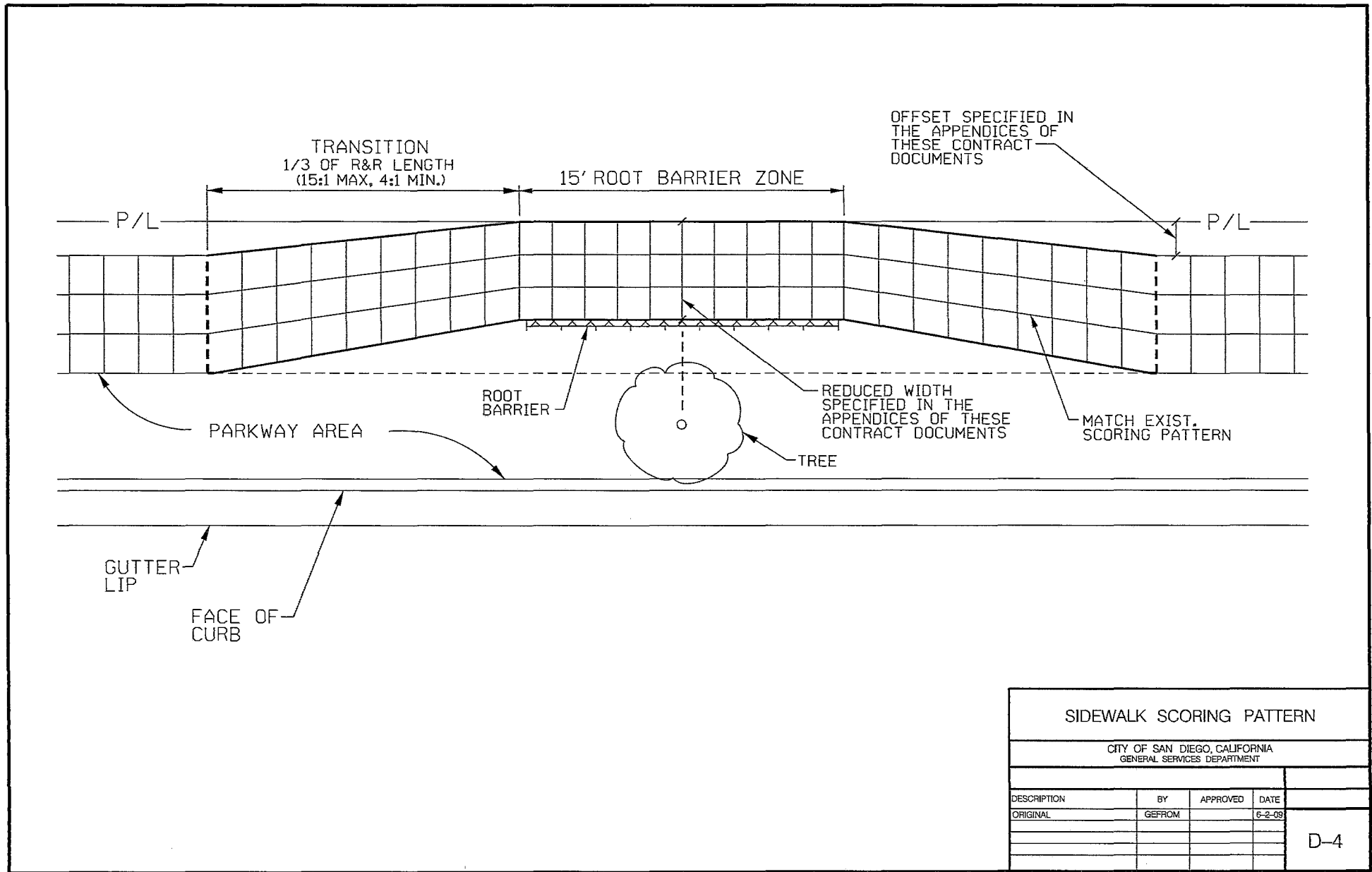

SIDEWALK SCORING PATTERN			
CITY OF SAN DIEGO, CALIFORNIA GENERAL SERVICES DEPARTMENT			
DESCRIPTION	BY	APPROVED	DATE
ORIGINAL	GEFROM		6-2-09

D-4

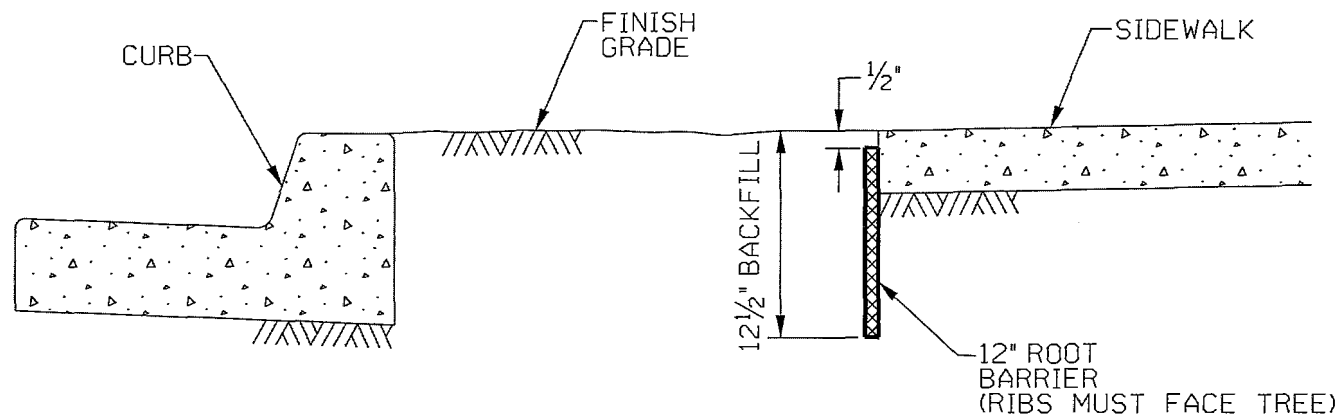

ROOT BARRIER AT SIDEWALK			
CITY OF SAN DIEGO, CALIFORNIA GENERAL SERVICES DEPARTMENT			
DESCRIPTION	BY	APPROVED	DATE
ORIGINAL	GEFROM		6-2-09

D-5



**APPENDIX H**  
**HAZARDOUS LABEL/FORMS**

<b>HAZARDOUS WASTE</b>			
STATE AND FEDERAL LAW PROHIBITS IMPROPER DISPOSAL IF FOUND, CONTACT THE NEAREST POLICE OR PUBLIC SAFETY AUTHORITY, OR THE U.S. ENVIRONMENTAL PROTECTION AGENCY OR THE CALIFORNIA DEPARTMENT OF HEALTH SERVICES			
GENERATOR NAME _____		IN TOX. PHONE _____	
ADDRESS _____		CITY _____ STATE _____ ZIP _____	
EPA ID NO. _____		UNIFORM DOCUMENT NO. _____	
CALIF. WASTE NO. _____		CALIFORNIA AGENCY STOREY DATE _____	
CONTENTS, COMPOSITION _____			
PREPARED BY _____			
SHIPPING NAME _____			
TECHNICAL NAME (S) _____			
UNDA NO. WITH PROPS _____			
FEDERAL STATE		HAZARDOUS PROPERTIES	
<input type="checkbox"/> FLUO	<input type="checkbox"/> LIQID	<input type="checkbox"/> CORROSIVE	<input type="checkbox"/> REACTIVE
<input type="checkbox"/> FLAMMABLE		<input type="checkbox"/> TOXIC	
<b>HANDLE WITH CARE!</b>			
CONTAINS HAZARDOUS OR TOXIC WASTES			

# INCIDENT/RELEASE ASSESSMENT FORM <sup>1</sup>

## If you have an emergency, Call 911

Handlers of hazardous materials are required to report releases. The following is a tool to be used for assessing if a release is reportable. Additionally, a non-reportable release incident form is provided to document why a release is not reported (see back).

### Questions for Incident Assessment:

	YES	NO
1. Was anyone killed or injured, or did they require medical care or admitted to a hospital for observation?	<input type="checkbox"/>	<input type="checkbox"/>
2. Did anyone, other than employees in the immediate area of the release, evacuate?	<input type="checkbox"/>	<input type="checkbox"/>
3. Did the release cause off-site damage to public or private property?	<input type="checkbox"/>	<input type="checkbox"/>
4. Is the release greater than or equal to a reportable quantity (RQ)?	<input type="checkbox"/>	<input type="checkbox"/>
5. Was there an uncontrolled or unpermitted release to the air?	<input type="checkbox"/>	<input type="checkbox"/>
6. Did an uncontrolled or unpermitted release escape secondary containment, or extend into any sewers, storm water conveyance systems, utility vaults and conduits, wetlands, waterways, public roads, or off site?	<input type="checkbox"/>	<input type="checkbox"/>
7. Will control, containment, decontamination, and/or clean up require the assistance of federal, state, county, or municipal response elements?	<input type="checkbox"/>	<input type="checkbox"/>
8. Was the release or threatened release involving an unknown material or contains an unknown hazardous constituent?	<input type="checkbox"/>	<input type="checkbox"/>
9. Is the incident a threatened release (a condition creating a substantial probability of harm that requires immediate action to prevent, reduce, or mitigate damages to persons, property, or the environment)?	<input type="checkbox"/>	<input type="checkbox"/>
10. Is there an increased potential for secondary effects including fire, explosion, line rupture, equipment failure, or other outcomes that may endanger or cause exposure to employees, the general public, or the environment?	<input type="checkbox"/>	<input type="checkbox"/>

If the answer is YES to any of the above questions – report the release to the California Office of Emergency Services at 800-852-7550 and the local CUPA daytime: (619) 338-2284, after hours: (858) 565-5255. Note: other state and federal agencies may require notification depending on the circumstances.

\*Call 911 in an emergency\*

If all answers are NO, complete a Non Reportable Release Incident Form (page 2 of 2) and keep readily available. Documenting why a “no” response was made to each question will serve useful in the event questions are asked in the future, and to justify not reporting to an outside regulatory agency.

If in doubt, report the release.

<sup>1</sup> This document is a guide for accessing when hazardous materials release reporting is required by Chapter 6.95 of the California Health and Safety Code. It does not replace good judgment, Chapter 6.95, or other state or federal release reporting requirements.



**EMERGENCY RELEASE FOLLOW - UP NOTICE REPORTING FORM**

<b>A</b>	BUSINESS NAME	FACILITY EMERGENCY CONTACT & PHONE NUMBER ( ) -
<b>B</b>	INCIDENT DATE MO DAY YR	TIME OES NOTIFIED (use 24 hr time)
<b>C</b>	INCIDENT ADDRESS LOCATION	CITY / COMMUNITY COUNTY ZIP
<b>D</b>	CHEMICAL OR TRADE NAME (print or type)	CAS Number
<b>E</b>	CHECK IF CHEMICAL IS LISTED IN 40 CFR 355, APPENDIX A <input type="checkbox"/>	CHECK IF RELEASE REQUIRES NOTIFICATION UNDER 42 U.S.C. Section 9603 (a) <input type="checkbox"/>
<b>F</b>	PHYSICAL STATE CONTAINED <input type="checkbox"/> SOLID <input type="checkbox"/> LIQUID <input type="checkbox"/> GAS	PHYSICAL STATE RELEASED <input type="checkbox"/> SOLID <input type="checkbox"/> LIQUID <input type="checkbox"/> GAS
<b>G</b>	ENVIRONMENTAL CONTAMINATION <input type="checkbox"/> AIR <input type="checkbox"/> WATER <input type="checkbox"/> GROUND <input type="checkbox"/> OTHER	QUANTITY RELEASED TIME OF RELEASE DURATION OF RELEASE — DAYS — HOURS — MINUTES
<b>H</b>	ACTIONS TAKEN	
<b>I</b>	KNOWN OR ANTICIPATED HEALTH EFFECTS (Use the comments section for addition information) <input type="checkbox"/> ACUTE OR IMMEDIATE (explain) _____ <input type="checkbox"/> CHRONIC OR DELAYED (explain) _____ <input type="checkbox"/> NOT KNOWN (explain) _____	
<b>J</b>	ADVICE REGARDING MEDICAL ATTENTION NECESSARY FOR EXPOSED INDIVIDUALS	
<b>K</b>	COMMENTS (INDICATE SECTION (A - G) AND ITEM WITH COMMENTS OR ADDITIONAL INFORMATION)	
<b>L</b>	CERTIFICATION: I certify under penalty of law that I have personally examined and I am familiar with the information submitted and believe the submitted information is true, accurate, and complete. REPORTING FACILITY REPRESENTATIVE (print or type) _____ SIGNATURE OF REPORTING FACILITY REPRESENTATIVE _____ DATE: _____	

## **EMERGENCY RELEASE FOLLOW-UP NOTICE REPORTING FORM INSTRUCTIONS**

### **GENERAL INFORMATION:**

Chapter 6.95 of Division 20 of the California Health and Safety Code requires that written emergency release follow-up notices prepared pursuant to 42 U.S.C. § 11004, be submitted using this reporting form. Non-permitted releases of reportable quantities of Extremely Hazardous Substances (listed in 40 CFR 355, appendix A) or of chemicals that require release reporting under section 103(a) of the Comprehensive Environmental Response, Compensation, and Liability Act of 1980 [42 U.S.C. § 9603(a)] must be reported on the form, as soon as practicable, but no later than 30 days, following a release. The written follow-up report is required in addition to the verbal notification.

### **BASIC INSTRUCTIONS:**

- The form, when filled out, reports follow-up information required by 42 U.S.C § 11004. Ensure that all information requested by the form is provided as completely as possible.
- If the incident involves reportable releases of more than one chemical, prepare one report form for each chemical released.
- If the incident involves a series of separate releases of chemical(s) at different times, the releases should be reported on separate reporting forms.

### **SPECIFIC INSTRUCTIONS:**

Block A: Enter the name of the business and the name and phone number of a contact person who can provide detailed facility information concerning the release.

Block B: Enter the date of the incident and the time that verbal notification was made to OES. The OES control number is provided to the caller by OES at the time verbal notification is made. Enter this control number in the space provided.

Block C: Provide information pertaining to the location where the release occurred. Include the street address, the city or community, the county and the zip code.

Block D: Provide information concerning the specific chemical that was released. Include the chemical or trade name and the Chemical Abstract Service (CAS) number. Check all categories that apply. Provide best available information on quantity, time and duration of the release.

Block E: Indicate all actions taken to respond to and contain the release as specified in 42 U.S.C. § 11004(c).

Block F: Check the categories that apply to the health effects that occurred or could result from the release. Provide an explanation or description of the effects in the space provided. Use Block H for additional comments/information if necessary to meet requirements specified in 42 U.S.C. § 11004(c).

Block G: Include information on the type of medical attention required for exposure to the chemical released. Indicate when and how this information was made available to individuals exposed and to medical personnel, if appropriate for the incident, as specified in 42 U.S.C. § 11004(c).

Block H: List any additional pertinent information.

Block I: Print or type the name of the facility representative submitting the report. Include the official signature and the date that the form was prepared.

### **MAIL THE COMPLETED REPORT TO:**

**State Emergency Response Commission (SERC)  
Attn: Section 304 Reports  
Hazardous Materials Unit  
3650 Schriever Avenue  
Mather, CA 95655**

NOTE: Authority cited: Sections 25503, 25503.1 and 25507.1, Health and Safety Code. Reference: Sections 25503(b)(4), 25503.1, 25507.1, 25518, and 25520, Health and Safety Code.

**APPENDIX I**  
**SAMPLE OF PUBLIC NOTICES**



## PROJECT NAME

### **Trenching on your street is complete.**

#### **What you need to know:**

- Pipe installation on your street is complete and construction crews are now installing new pipeline for this project at another location.
- You may see temporary trench plates or trench caps for some time –even after construction activities have concluded on your street.

#### **Street resurfacing:**

- Your Streets will be resurfaced once the entire pipeline project is complete.
- Concrete streets will not be resurfaced curb to curb; only the trench will be backfilled.
- Street resurfacing may be delayed due to the City's slurry seal moratorium.

#### **Estimated resurfacing completion on your street:**

(Insert Date-Month and Year)

**For questions related to this work**

**Call: (619) 533-4207**

**Email: [engineering@sandiego.gov](mailto:engineering@sandiego.gov)**

**Visit: [sandiego.gov/CIP](http://sandiego.gov/CIP)**



This information is available in alternative formats upon request.





**APPENDIX J**

**ADVANCED METERING INFRASTRUCTURE (AMI) DEVICE PROTECTION**

## Protecting AMI Devices in Meter Boxes and on Street Lights

The Public Utilities Department (PUD) has begun the installation of the Advanced Metering Infrastructure (AMI) technology as a new tool to enhance water meter reading accuracy and efficiency, customer service and billing, and to be used by individual accounts to better manage the efficient use of water. **All AMI devices shall be protected per Section 5-2, "Protection", of the 2015 Whitebook.**

AMI technology allows water meters to be read electronically rather than through direct visual inspection by PUD field staff. This will assist PUD staff and customers in managing unusual consumption patterns which could indicate leaks or meter tampering on a customer's property.

Three of the main components of an AMI system are the:

- A. Endpoints, see Photo 1:

**Photo 1**

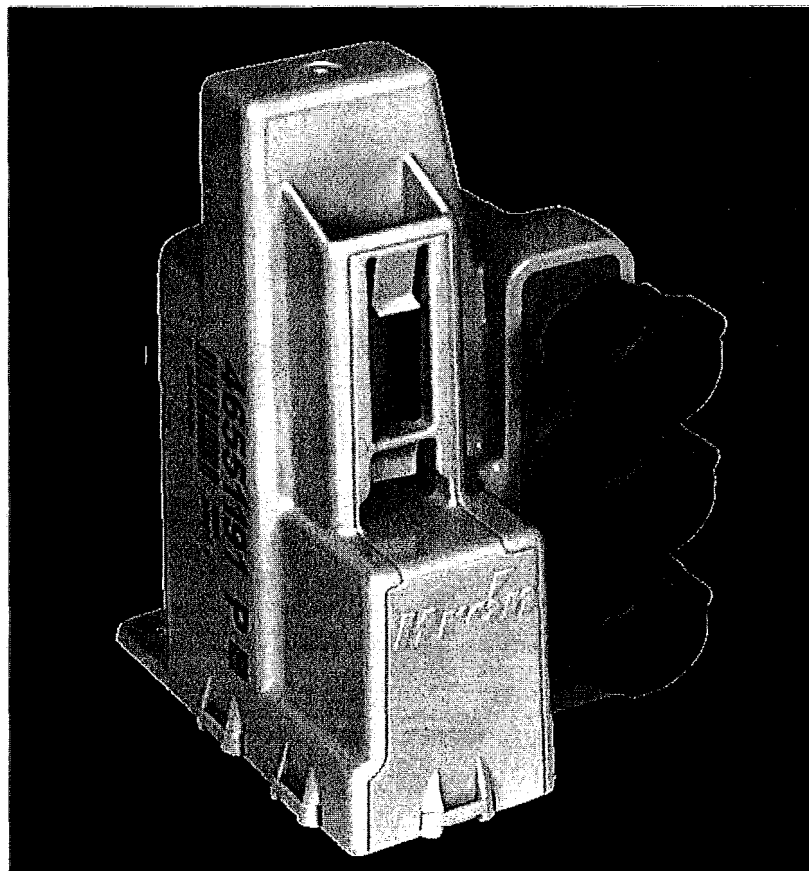

- B. AMI Antenna attached to Endpoint (antenna not always required), see Photo 2:

**Photo 2**

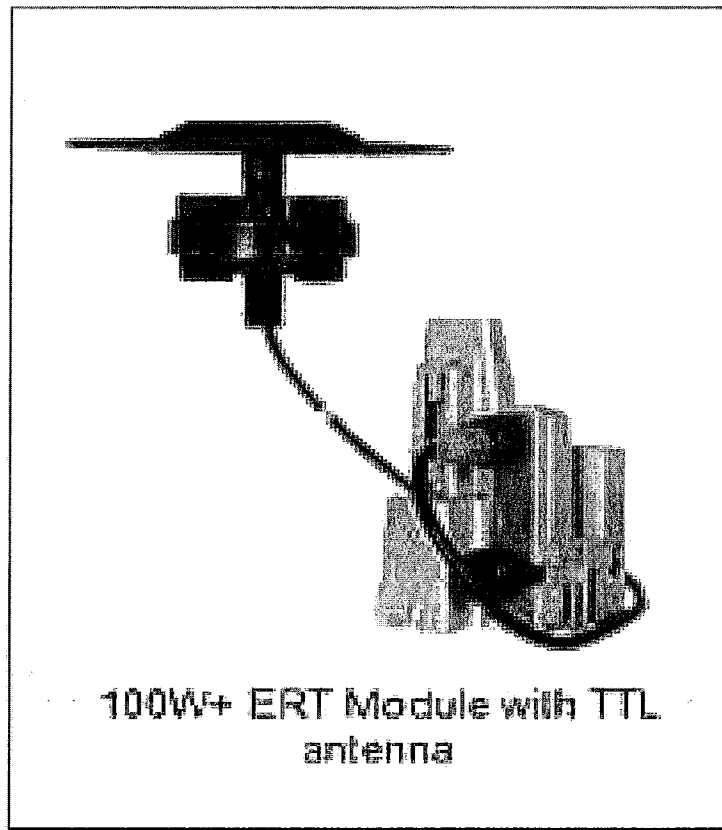

Network Devices, see Photo 3:

**Photo 3**

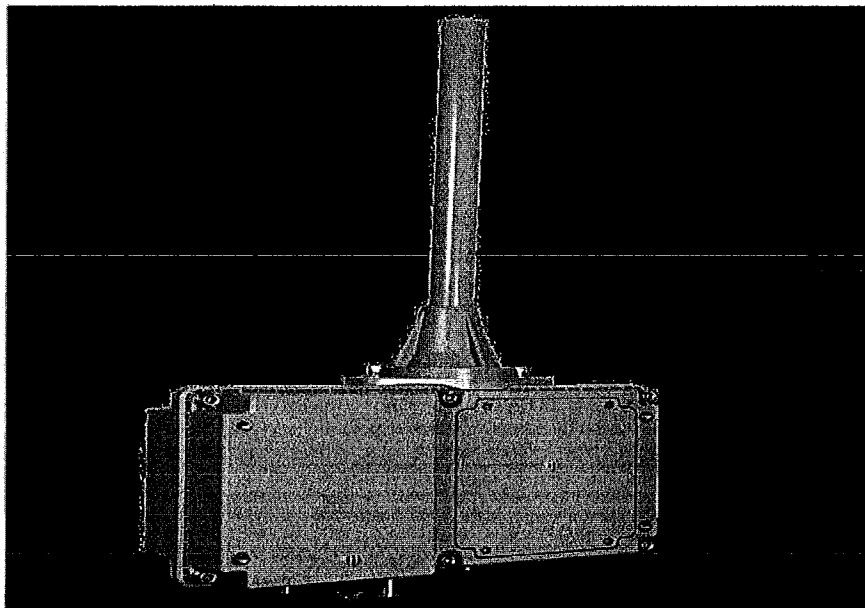

AMI endpoints transmit meter information to the AMI system and will soon be on the vast majority of meters in San Diego. These AMI devices provide interval consumption data to the PUD's Customer Support Division. If these devices are damaged or communication is interrupted, this Division will be alerted of the situation. The endpoints are installed in water meter boxes, coffins, and vaults adjacent to the meter. A separate flat round antenna may also be installed through the meter box lid. This antenna is connected to the endpoint via cable. The following proper installation shall be implemented when removing the lid to avoid damaging the antenna, cable, and/or endpoint. Photo 4 below demonstrates a diagram of the connection:

**Photo 4**

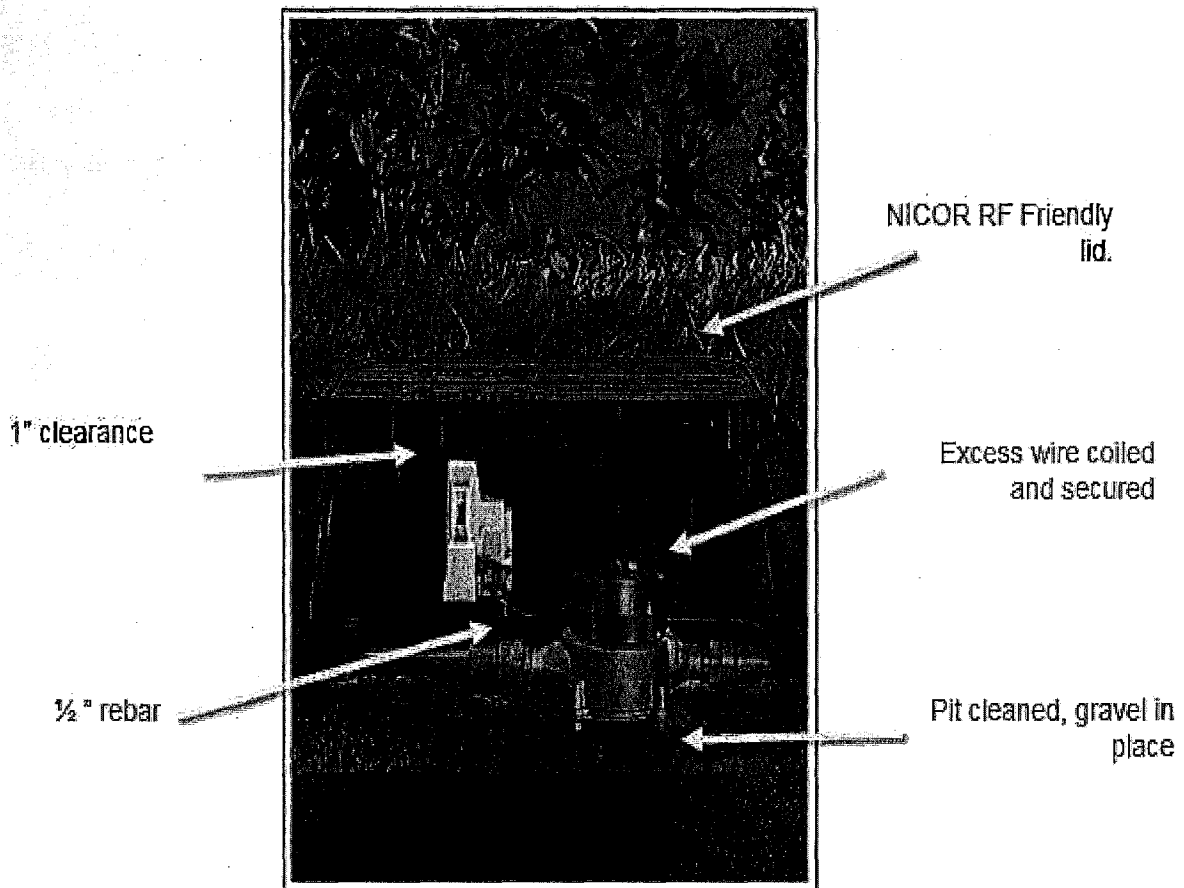

The AMI device ERT/Endpoint/Transmitter shall be positioned and installed as discussed in this Appendix. If the ERT/Endpoint/Transmitter is disturbed, it shall be re-installed and returned to its original installation with the end points pointed upwards as shown below in Photo 5.

**The PUD's code compliance staff will issue citations and invoices to you for any damaged AMI devices that are not re-installed as discussed in the Contract Document**

Photo 5 below shows a typical installation of an AMI endpoint on a water meter.

**Photo 5**

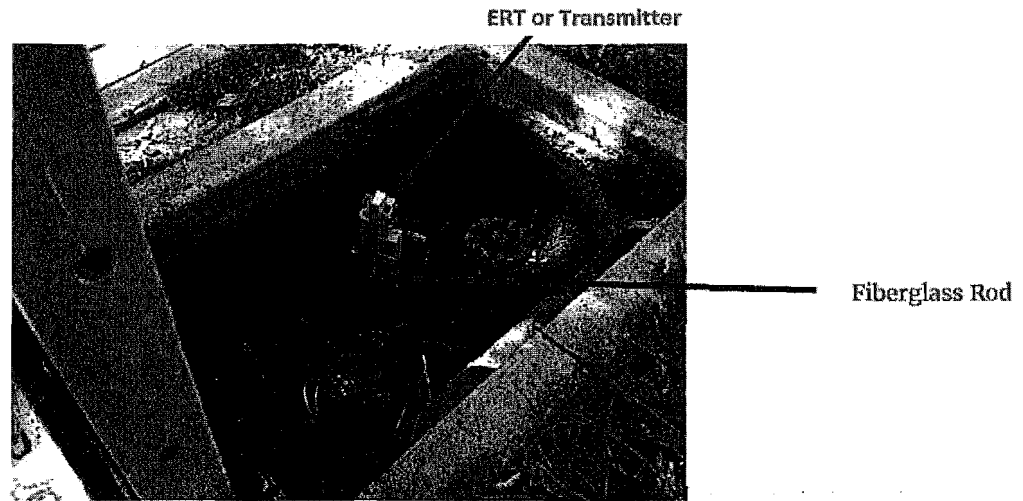

Photo 6 below is an example of disturbance that shall be avoided:

**Photo 6**

The antenna was drilled into the lid and now it is removed



**You are responsible when working in and around meter boxes.** If you encounter these endpoints, use proper care and do not disconnect them from the registers on top of the water meter. If the lid has an antenna drilled through, do not change or tamper with the lid and inform the Resident Engineer immediately about the location of that lid. Refer to Photo 7 below:

**Photo 7**



Another component of the AMI system are the Network Devices. The Network Devices are strategically placed units (mainly on street light poles) that collect interval meter reading data from multiple meters for transmission to the Department Control Computer. **If you come across any of these devices on street lights that will be removed or replaced (refer to Photos 8 and 9 below), notify AMI Project Manager Arwa Sayed at (619) 362-0121 immediately.**

Photo 8 shows an installed network device on a street light. On the back of each Network Device is a sticker with contact information. See Photo 9. **Call PUD Water Emergency Repairs at 619-515-3525 if your work will impact these street lights.** These are assets that belong to the City of San Diego and you shall be responsible for any costs of disruption of this network.

**Photo 8**

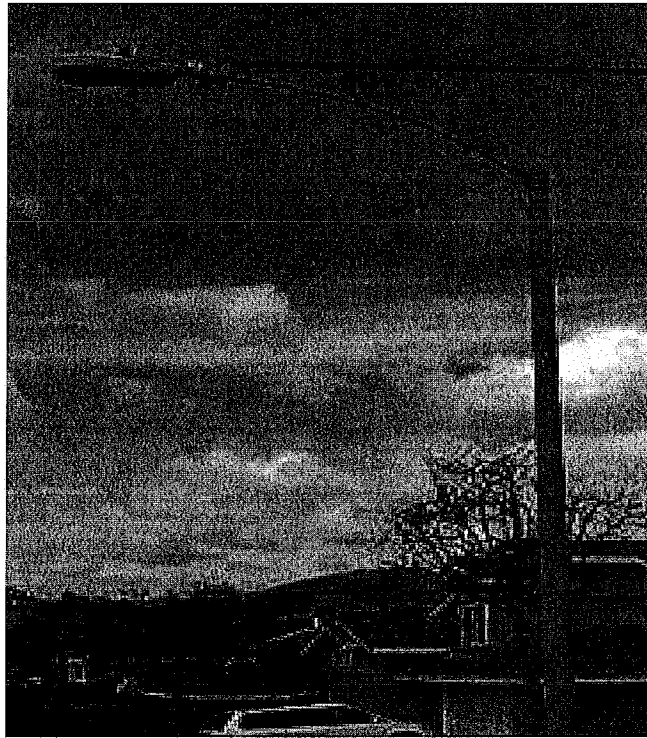

**Network Device**

**Photo 9**



**If you encounter any bad installations, disconnected/broken/buried endpoints, or inadvertently damage any AMI devices or cables, notify the Resident Engineer immediately. The Resident Engineer will then immediately contact the AMI Project Manager, Arwa Sayed, at (619) 362-0121.**

**ATTACHMENT F**  
**INTENTIONALLY LEFT BLANK**



**ATTACHMENT G**  
**CONTRACT AGREEMENT**

## ATTACHMENT G

### CONTRACT AGREEMENT

---

#### CONSTRUCTION CONTRACT

This contract is made and entered into between THE CITY OF SAN DIEGO, a municipal corporation, herein called "City", and **Portillo Concrete, Inc.**, herein called "Contractor" for construction of **Sidewalk Replacement Group 1601; Bid No.: K-17-1508-DBB-3**; in the amount of **Eight Hundred Thirty Six Thousand Two Hundred Fifty Seven Dollars and 40/100 (\$836,257.40)**, which is comprised of the Base Bid.

IN CONSIDERATION of the payments to be made hereunder and the mutual undertakings of the parties hereto, City and Contractor agree as follows:

1. The following are incorporated into this contract as though fully set forth herein:
  - (a) The attached Faithful Performance and Payment Bonds.
  - (b) The attached Proposal included in the Bid documents by the Contractor.
  - (c) Reference Standards listed in the Instruction to Bidders and the Supplementary Special Provisions (SSP).
  - (d) That certain documents entitled **Sidewalk Replacement Group 1601**, on file in the office of the Public Works Department as Document No. **B16027**, as well as all matters referenced therein.
2. The Contractor shall perform and be bound by all the terms and conditions of this contract and in strict conformity therewith shall perform and complete in a good and workmanlike manner **Sidewalk Replacement Group 1601, K-17-1508-DBB-3**, San Diego, California.
3. For such performances, the City shall pay to Contractor the amounts set forth at the times and in the manner and with such additions or deductions as are provided for in this contract, and the Contractor shall accept such payment in full satisfaction of all claims incident to such performances.
4. No claim or suit whatsoever shall be made or brought by Contractor against any officer, agent, or employee of the City for or on account of anything done or omitted to be done in connection with this contract, nor shall any such officer, agent, or employee be liable hereunder.
5. This contract is effective as of the date that the Mayor or designee signs the agreement.

CONTRACT AGREEMENT (continued)

IN WITNESS WHEREOF, this Agreement is signed by the City of San Diego, acting by and through its Mayor or designee, pursuant to Municipal Code §22.3102 authorizing such execution

THE CITY OF SAN DIEGO

APPROVED AS TO FORM

Mara W. Elliott, City Attorney

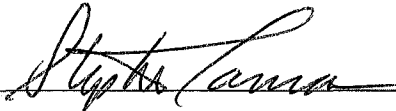
By 

By 

Print Name: Stephen Samara  
Principal Contract Specialist  
Public Works Department

Print Name: Jeremy Jung  
Deputy City Attorney

Date: 3-8-17

Date: 14 MAR 2017

CONTRACTOR

By 

Print Name: Mario Portillo

Title: President/CEO

Date: 01/27/2017

City of San Diego License No.: B1996006538

State Contractor's License No.: 680144

DEPARTMENT OF INDUSTRIAL RELATIONS (DIR) REGISTRATION NUMBER: 1000004385

## CERTIFICATIONS AND FORMS

**The Bidder, by submitting its electronic bid, agrees to and certifies under penalty of perjury under the laws of the State of California, that the certifications, forms and affidavits submitted as part of this bid are true and correct.**

## **Bidder's General Information**

To the City of San Diego:

Pursuant to "Notice Inviting Bids", specifications, and requirements on file with the City Clerk, and subject to all provisions of the Charter and Ordinances of the City of San Diego and applicable laws and regulations of the United States and the State of California, the undersigned hereby proposes to furnish to the City of San Diego, complete at the prices stated herein, the items or services hereinafter mentioned. The undersigned further warrants that this bid is not made in the interest of, or on behalf of, any undisclosed person, partnership, company, association, organization, or corporation; that the bid is genuine and not collusive or sham; that the bidder has not directly or indirectly induced or solicited any other bidder to put in a false or sham bid, and has not directly or indirectly colluded, conspired, connived, or agreed with any bidder or anyone else to put in a sham bid, or that anyone shall refrain from bidding; that the bidder has not in any manner, directly or indirectly, sought by agreement, communication, or conference with anyone to fix the bid price of the bidder or any other bidder, or to fix any overhead, profit, or cost element of the bid price, or of that of any other bidder, or to secure any advantage against the public body awarding the contract of anyone interested in the proposed contract; that all statements contained in the bid are true; and, further, that the bidder has not, directly or indirectly, submitted his or her bid price or any breakdown thereof, or the contents thereof, or divulged information or data relative thereto, or paid, and will not pay, any fee to any corporation, partnership, company, association, organization, bid depository, or to any member or agent thereof to effectuate a collusive or sham bid.

The undersigned bidder(s) further warrants that bidder(s) has thoroughly examined and understands the entire Contract Documents (plans and specifications) and the Bidding Documents therefore, and that by submitting said Bidding Documents as its bid proposal, bidder(s) acknowledges and is bound by the entire Contract Documents, including any addenda issued thereto, as such Contract Documents incorporated by reference in the Bidding Documents.

**NON-COLLUSION AFFIDAVIT TO BE EXECUTED BY BIDDER AND SUBMITTED WITH BID  
UNDER 23 UNITED STATES CODE 112 AND PUBLIC CONTRACT CODE 7106**

State of California  
County of San Diego

The bidder, being first duly sworn, deposes and says that he or she is authorized by the party making the foregoing bid that the bid is not made in the interest of, or on behalf of, any undisclosed person, partnership, company, association, organization, or corporation; that the bid is genuine and not collusive or sham; that the bidder has not directly or indirectly induced or solicited any other bidder to put in a false or sham bid, and has not directly or indirectly colluded, conspired, connived, or agreed with any bidder or anyone else to put in a sham bid, or that anyone shall refrain from bidding; that the bidder has not in any manner, directly or indirectly, sought by agreement, communication, or conference with anyone to fix the bid price of the bidder or any other bidder, or to fix any overhead, profit, or cost element of the bid price, or of that of any other bidder, or to secure any advantage against the public body awarding the contract of anyone interested in the proposed contract; that all statements contained in the bid are true; and further, that the bidder has not, directly or indirectly, submitted his or her bid price or any breakdown thereof, or the contents thereof, or divulged information or data relative thereto, or paid, and will not pay, any fee to any corporation, partnership, company association, organization, bid depository, or to any member or agent thereof to effectuate a collusive or sham bid.

## CONTRACTOR CERTIFICATION

---

### DRUG-FREE WORKPLACE

I hereby certify that I am familiar with the requirements of San Diego City Council Policy No. 100-17 regarding Drug-Free Workplace as outlined in the WHITEBOOK, Section 7-13.3, "Drug-Free Workplace", of the project specifications, and that;

This company has in place a drug-free workplace program that complies with said policy. I further certify that each subcontract agreement for this project contains language which indicates the subcontractor's agreement to abide by the provisions of subdivisions a) through c) of the policy as outlined.

## CONTRACTOR CERTIFICATION

---

### AMERICAN WITH DISABILITIES ACT (ADA) COMPLIANCE CERTIFICATION

I hereby certify that I am familiar with the requirements of San Diego City Council Policy No. 100-4 regarding the American With Disabilities Act (ADA) outlined in the WHITEBOOK, Section 7-13.2, "American With Disabilities Act", of the project specifications, and that:

This company has in place workplace program that complies with said policy. I further certify that each subcontract agreement for this project contains language which indicates the subcontractor's agreement to abide by the provisions of the policy as outlined.



## CONTRACTOR CERTIFICATION

---

### CONTRACTOR STANDARDS – PLEDGE OF COMPLIANCE

I declare under penalty of perjury that I am authorized to make this certification on behalf of the company submitting this bid/proposal, that as Contractor, I am familiar with the requirements of City of San Diego Municipal Code § 22.3004 regarding Contractor Standards as outlined in the WHITEBOOK, Section 7-13.4, ("Contractor Standards"), of the project specifications, and that Contractor has complied with those requirements.

I further certify that each of the Contractor's subcontractors whose subcontracts are greater than \$50,000 in value has completed a Pledge of Compliance attesting under penalty of perjury of having complied with City of San Diego Municipal Code § 22.3004.

## CONTRACTOR CERTIFICATION

---

### Equal Benefits Ordinance Certification

I declare under penalty of perjury that I am familiar with the requirements of and in compliance with the City of San Diego Municipal Code § 22.4300 regarding Equal Benefits Ordinance.

**AFFIDAVIT OF DISPOSAL**

(To be submitted upon completion of Construction pursuant to the contracts Certificate of Completion)

**WHEREAS**, on the \_\_\_\_\_ DAY OF \_\_\_\_\_, 2\_\_\_\_ the undersigned entered into and executed a contract with the City of San Diego, a municipal corporation, for:

\_\_\_\_\_  
(Name of Project or Task)

as particularly described in said contract and identified as Bid No. **K-17-1508-DBB-3**; SAP No. (WBS/IO/CC): **B-16027** and **WHEREAS**, the specification of said contract requires the Contractor to affirm that "all brush, trash, debris, and surplus materials resulting from this project have been disposed of in a legal manner"; and **WHEREAS**, said contract has been completed and all surplus materials disposed of:

\_\_\_\_\_  
\_\_\_\_\_  
**NOW, THEREFORE**, in consideration of the final payment by the City of San Diego to said Contractor under the terms of said contract, the undersigned Contractor, does hereby affirm that all surplus materials as described in said contract have been disposed of at the following location(s)

\_\_\_\_\_  
\_\_\_\_\_  
and that they have been disposed of according to all applicable laws and regulations.

Dated this \_\_\_\_\_ DAY OF \_\_\_\_\_, \_\_\_\_\_.

By: \_\_\_\_\_  
Contractor

**ATTEST:**

State of \_\_\_\_\_ County of \_\_\_\_\_

On this \_\_\_\_\_ DAY OF \_\_\_\_\_, 2\_\_\_\_, before the undersigned, a Notary Public in and for said County and State, duly commissioned and sworn, personally appeared \_\_\_\_\_ known to me to be the \_\_\_\_\_ Contractor named in the foregoing Release, and whose name is subscribed thereto, and acknowledged to me that said Contractor executed the said Release.

Notary Public in and for said County and State

**LIST OF SUBCONTRACTORS**

**PROVIDED FOR ILLUSTRATIVE PURPOSES ONLY - TO BE SUBMITTED IN ELECTRONIC FORMAT ONLY - SEE INSTRUCTIONS TO BIDDERS FOR FURTHER INFORMATION**

In accordance with the requirements of the "Subletting and Subcontracting Fair Practices Act", Section 4100, of the California Public Contract Code (PCC), the Bidder is to list below the name, address and license number of each Subcontractor who will perform work, labor, render services or specially fabricate and install a portion [type] of the work or improvement, in an amount of or in excess of 0.5% of the Contractor's total Bid. Failure to comply with this requirement may result in the Bid being rejected as non-responsive. The Contractor is to list only one Subcontractor for each portion of the Work. The Bidder's attention is directed to the Special Provisions - General; Paragraph 2-3 Subcontracts, which stipulates the percentage of the Work to be performed with the Bidder's own forces. The Bidder is to also list all SLBE, ELBE, DBE, DVBE, MBE, WBE, OBE, SDB, WoSB, HUBZone, and SDVOSB Subcontractors for which the Bidders are seeking recognition towards achieving any mandatory, voluntary, or both subcontracting participation percentages.

NAME, ADDRESS AND TELEPHONE NUMBER OF SUBCONTRACTOR	CONSTRUCTOR OR DESIGNER	SUBCONTRACTOR LICENSE NUMBER	TYPE OF WORK	DOLLAR VALUE OF SUBCONTRACT	MBE, WBE, DBE, DVBE, OBE, ELBE, SLBE, SDB, WoSB, HUBZone, OR SDVOSBⓐ	WHERE CERTIFIEDⓑ	CHECK IF JOINT VENTURE PARTNERSHIP
Name: _____ Address: _____ City: _____ State: _____ Zip: _____ Phone: _____ Email: _____							
Name: _____ Address: _____ City: _____ State: _____ Zip: _____ Phone: _____ Email: _____							

ⓐ As appropriate, Bidder shall identify Subcontractor as one of the following and shall include a valid proof of certification (except for OBE, SLBE and ELBE):

Certified Minority Business Enterprise	MBE	Certified Woman Business Enterprise	WBE
Certified Disadvantaged Business Enterprise	DBE	Certified Disabled Veteran Business Enterprise	DVBE
Other Business Enterprise	OBE	Certified Emerging Local Business Enterprise	ELBE
Certified Small Local Business Enterprise	SLBE	Small Disadvantaged Business	SDB
Woman-Owned Small Business	WoSB	HUBZone Business	HUBZone
Service-Disabled Veteran Owned Small Business	SDVOSB		

ⓑ As appropriate, Bidder shall indicate if Subcontractor is certified by:

City of San Diego	CITY	State of California Department of Transportation	CALTRANS
California Public Utilities Commission	CPUC		
State of California's Department of General Services	CADoGS	City of Los Angeles	LA
State of California	CA	U.S. Small Business Administration	SBA

**The Bidder will not receive any subcontracting participation percentages if the Bidder fails to submit the required proof of certification.**

**NAMED EQUIPMENT/MATERIAL SUPPLIER LIST**

**\*\*\* PROVIDED FOR ILLUSTRATIVE PURPOSES ONLY \*\*\* TO BE SUBMITTED IN ELECTRONIC FORMAT ONLY \*\*\* SEE INSTRUCTIONS TO BIDDERS FOR FURTHER INFORMATION**

NAME, ADDRESS AND TELEPHONE NUMBER OF VENDOR/SUPPLIER	MATERIALS OR SUPPLIES	DOLLAR VALUE OF MATERIAL OR SUPPLIES	SUPPLIER (Yes/No)	MANUFACTURER (Yes/No)	MBE, WBE, DBE, DVBE, OBE, ELBE, SLBE, SDB, WoSB, HUBZone, OR SDVOSB <sup>①</sup>	WHERE CERTIFIED <sup>②</sup>
Name: _____ Address: _____ City: _____ State: _____ Zip: _____ Phone: _____ Email: _____						
Name: _____ Address: _____ City: _____ State: _____ Zip: _____ Phone: _____ Email: _____						

- ① As appropriate, Bidder shall identify Vendor/Supplier as one of the following and shall include a valid proof of certification (except for OBE,SLBE and ELBE):
- |   |        |  |         |
|---|--------|--|---------|
| Certified Minority Business Enterprise        | MBE    | Certified Woman Business Enterprise            | WBE     |
| Certified Disadvantaged Business Enterprise   | DBE    | Certified Disabled Veteran Business Enterprise | DVBE    |
| Other Business Enterprise                     | OBE    | Certified Emerging Local Business Enterprise   | ELBE    |
| Certified Small Local Business Enterprise     | SLBE   | Small Disadvantaged Business                   | SDB     |
| Woman-Owned Small Business                    | WoSB   | HUBZone Business                               | HUBZone |
| Service-Disabled Veteran Owned Small Business | SDVOSB |  |         |
- ② As appropriate, Bidder shall indicate if Vendor/Supplier is certified by:
- |  |        |  |          |
|--|--------|--|----------|
| City of San Diego                                    | CITY   | State of California Department of Transportation | CALTRANS |
| California Public Utilities Commission               | CPUC   |  |          |
| State of California's Department of General Services | CADoGS | City of Los Angeles                              | LA       |
| State of California                                  | CA     | U.S. Small Business Administration               | SBA      |

**The Bidder will not receive any subcontracting participation percentages if the Bidder fails to submit the required proof of certification.**

## **ELECTRONICALLY SUBMITTED FORMS**

### **THE FOLLOWING FORMS MUST BE SUBMITTED IN PDF FORMAT WITH BID SUBMISSION**

The following forms are to be completed by the bidder and submitted (uploaded) electronically with the bid in PlanetBids.

**A. BID BOND – See Instructions to Bidders, Bidders Guarantee of Good Faith (Bid Security) for further instructions**

**B. CONTRACTOR'S CERTIFICATION OF PENDING ACTIONS**

**Bids will not be accepted until ALL forms are submitted as part of the bid submittal**

**BID BOND**

**See Instructions to Bidders, Bidder Guarantee of Good Faith  
(Bid Security)**

KNOW ALL MEN BY THESE PRESENTS,

That Portillo Concrete, Inc. as Principal, and  
The Ohio Casualty Insurance Company as Surety, are

held and firmly bound unto The City of San Diego hereinafter called "OWNER," in the sum of **10% OF THE TOTAL BID AMOUNT** for the payment of which sum, well and truly to be made, we bind ourselves, our heirs, executors, administrators, successors, and assigns, jointly and severally, firmly by these presents.

WHEREAS, said Principal has submitted a Bid to said OWNER to perform the WORK required under the bidding schedule(s) of the OWNER's Contract Documents entitled

Sidewalk Replacement Group 1601

NOW THEREFORE, if said Principal is awarded a contract by said OWNER and, within the time and in the manner required in the "Notice Inviting Bids" enters into a written Agreement on the form of agreement bound with said Contract Documents, furnishes the required certificates of insurance, and furnishes the required Performance Bond and Payment Bond, then this obligation shall be null and void, otherwise it shall remain in full force and effect. In the event suit is brought upon this bond by said OWNER and OWNER prevails, said Surety shall pay all costs incurred by said OWNER in such suit, including a reasonable attorney's fee to be fixed by the court.

SIGNED AND SEALED, this 1st day of December, 2016

Portillo Concrete, Inc. (SEAL)

The Ohio Casualty Insurance Company (SEAL)

(Principal)

(Surety)

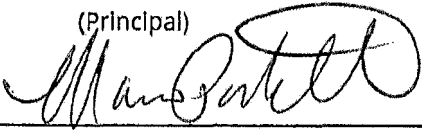
By: 

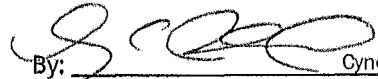
By:  Cyndi Beilman  
Attorney-in-Fact

(Signature)

(Signature)

(SEAL AND NOTARIAL ACKNOWLEDGEMENT OF SURETY)

# CALIFORNIA ALL-PURPOSE ACKNOWLEDGMENT

A notary public or other officer completing this certificate verifies only the identity of the individual who signed the document to which this certificate is attached, and not the truthfulness, accuracy, or validity of that document.

STATE OF CALIFORNIA

County of San Diego

}

On December 1, 2016 before me, Pam Davis, Notary Public,  
Date Insert Name of Notary exactly as it appears on the official seal

personally appeared Cyndi Bellman  
Name(s) of Signer(s)

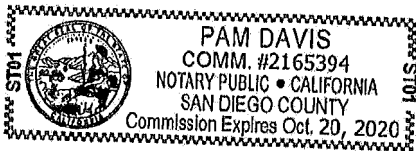

Place Notary Seal Above

who proved to me on the basis of satisfactory evidence to be the person(s) whose name(s) is/are subscribed to the within instrument and acknowledged to me that he/she/they executed the same in his/her/their authorized capacity(ies), and that by his/her/their signature(s) on the instrument the person(s), or the entity upon behalf of which the person(s) acted, executed the instrument.

I certify under PENALTY OF PERJURY under the laws of the State of California that the foregoing paragraph is true and correct.

Witness my hand and official seal.

Signature *Pam Davis*  
Signature of Notary Public Pam Davis

## OPTIONAL

Though the information below is not required by law, it may prove valuable to persons relying on the document and could prevent fraudulent removal and reattachment of the form to another document.

### Description of Attached Document

Title or Type of Document: \_\_\_\_\_

Document Date: \_\_\_\_\_ Number of Pages: \_\_\_\_\_

Signer(s) Other Than Named Above: \_\_\_\_\_

### Capacity(ies) Claimed by Signer(s)

Signer's Name: \_\_\_\_\_

- Individual
- Corporate Officer — Title(s): \_\_\_\_\_
- Partner  Limited  General
- Attorney in Fact
- Trustee
- Guardian or Conservator
- Other: \_\_\_\_\_

**RIGHT THUMBPRINT  
OF SIGNER**

Top of thumb here

Signer is Representing:  
\_\_\_\_\_  
\_\_\_\_\_  
\_\_\_\_\_

Signer's Name: \_\_\_\_\_

- Individual
- Corporate Officer — Title(s): \_\_\_\_\_
- Partner  Limited  General
- Attorney in Fact
- Trustee
- Guardian or Conservator
- Other: \_\_\_\_\_

**RIGHT THUMBPRINT  
OF SIGNER**

Top of thumb here

Signer is Representing:  
\_\_\_\_\_  
\_\_\_\_\_  
\_\_\_\_\_



**THIS POWER OF ATTORNEY IS NOT VALID UNLESS IT IS PRINTED ON RED BACKGROUND.**

This Power of Attorney limits the acts of those named herein, and they have no authority to bind the Company except in the manner and to the extent herein stated.

Certificate No. 7413752

American Fire and Casualty Company  
The Ohio Casualty Insurance Company

Liberty Mutual Insurance Company  
West American Insurance Company

**POWER OF ATTORNEY**

KNOWN ALL PERSONS BY THESE PRESENTS: That American Fire & Casualty Company and The Ohio Casualty Insurance Company are corporations duly organized under the laws of the State of New Hampshire, that Liberty Mutual Insurance Company is a corporation duly organized under the laws of the State of Massachusetts, and West American Insurance Company is a corporation duly organized under the laws of the State of Indiana (herein collectively called the "Companies"), pursuant to and by authority herein set forth, does hereby name, constitute and appoint, Anne Wright; Cyndi Bellman; Dana Michaeils

all of the city of La Mesa, state of CA each individually if there be more than one named, its true and lawful attorney-in-fact to make, execute, seal, acknowledge and deliver, for and on its behalf as surety and as its act and deed, any and all undertakings, bonds, recognizances and other surety obligations, in pursuance of these presents and shall be as binding upon the Companies as if they have been duly signed by the president and attested by the secretary of the Companies in their own proper persons.

IN WITNESS WHEREOF, this Power of Attorney has been subscribed by an authorized officer or official of the Companies and the corporate seals of the Companies have been affixed thereto this 8th day of July, 2016.

American Fire and Casualty Company  
The Ohio Casualty Insurance Company  
Liberty Mutual Insurance Company  
West American Insurance Company

By: David M. Carey  
David M. Carey, Assistant Secretary

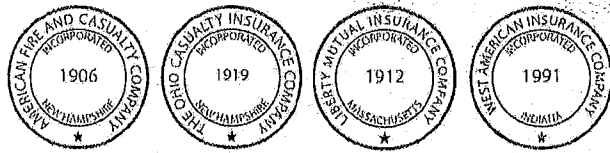

STATE OF PENNSYLVANIA ss  
COUNTY OF MONTGOMERY

On this 8th day of July, 2016, before me personally appeared David M. Carey, who acknowledged himself to be the Assistant Secretary of American Fire and Casualty Company, Liberty Mutual Insurance Company, The Ohio Casualty Insurance Company, and West American Insurance Company, and that he, as such, being authorized so to do, execute the foregoing instrument for the purposes therein contained by signing on behalf of the corporations by himself as a duly authorized officer.

IN WITNESS WHEREOF, I have hereunto subscribed my name and affixed my notarial seal at Plymouth Meeting, Pennsylvania, on the day and year first above written.



COMMONWEALTH OF PENNSYLVANIA  
Notarial Seal  
Teresa Pastella, Notary Public  
Plymouth Twp., Montgomery County  
My Commission Expires March 28, 2017  
Member, Pennsylvania Association of Notaries

By: Teresa Pastella  
Teresa Pastella, Notary Public

This Power of Attorney is made and executed pursuant to and by authority of the following By-laws and Authorizations of American Fire and Casualty Company, The Ohio Casualty Insurance Company, Liberty Mutual Insurance Company, and West American Insurance Company which resolutions are now in full force and effect reading as follows:

**ARTICLE IV - OFFICERS** - Section 12. Power of Attorney. Any officer or other official of the Corporation authorized for that purpose in writing by the Chairman or the President, and subject to such limitations as the Chairman or the President may prescribe, shall appoint such attorneys-in-fact, as may be necessary to act in behalf of the Corporation to make, execute, seal, acknowledge and deliver as surety any and all undertakings, bonds, recognizances and other surety obligations. Such attorneys-in-fact, subject to the limitations set forth in their respective powers of attorney, shall have full power to bind the Corporation by their signature and execution of any such instruments and to attach thereto the seal of the Corporation. When so executed, such instruments shall be as binding as if signed by the President and attested to by the Secretary. Any power or authority granted to any representative or attorney-in-fact under the provisions of this article may be revoked at any time by the Board, the Chairman, the President or by the officer or officers granting such power or authority.

**ARTICLE XIII - Execution of Contracts** - SECTION 5. Surety Bonds and Undertakings. Any officer of the Company authorized for that purpose in writing by the chairman or the president, and subject to such limitations as the chairman or the president may prescribe, shall appoint such attorneys-in-fact, as may be necessary to act in behalf of the Company to make, execute, seal, acknowledge and deliver as surety any and all undertakings, bonds, recognizances and other surety obligations. Such attorneys-in-fact subject to the limitations set forth in their respective powers of attorney, shall have full power to bind the Company by their signature and execution of any such instruments and to attach thereto the seal of the Company. When so executed such instruments shall be as binding as if signed by the president and attested by the secretary.

**Certificate of Designation** - The President of the Company, acting pursuant to the Bylaws of the Company, authorizes David M. Carey, Assistant Secretary to appoint such attorneys-in-fact as may be necessary to act on behalf of the Company to make, execute, seal, acknowledge and deliver as surety any and all undertakings, bonds, recognizances and other surety obligations.

**Authorization** - By unanimous consent of the Company's Board of Directors, the Company consents that facsimile or mechanically reproduced signature of any assistant secretary of the Company, wherever appearing upon a certified copy of any power of attorney issued by the Company in connection with surety bonds, shall be valid and binding upon the Company with the same force and effect as though manually affixed.

I, Gregory W. Davenport, the undersigned, Assistant Secretary, of American Fire and Casualty Company, The Ohio Casualty Insurance Company, Liberty Mutual Insurance Company, and West American Insurance Company do hereby certify that the original power of attorney of which the foregoing is a full, true and correct copy of the Power of Attorney executed by said Companies, is in full force and effect and has not been revoked.

IN TESTIMONY WHEREOF, I have hereunto set my hand and affixed the seals of said Companies this 1st day of December, 2016.

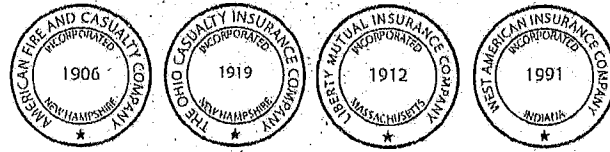

By: Gregory W. Davenport  
Gregory W. Davenport, Assistant Secretary

Not valid for mortgage, note, loan, letter of credit, currency rate, interest rate or residual value guarantees.

To confirm the validity of this Power of Attorney call 1-610-832-8240 between 9:00 am and 4:30 pm EST on any business day.

**CONTRACTOR'S CERTIFICATION OF PENDING ACTIONS**

As part of its bid or proposal (Non-Price Proposal in the case of Design-Build contracts), the Bidder shall provide to the City a list of all instances within the past 10 years where a complaint was filed or pending against the Bidder in a legal or administrative proceeding alleging that Bidder discriminated against its employees, subcontractors, vendors or suppliers, and a description of the status or resolution of that complaint, including any remedial action taken.

CHECK ONE BOX ONLY.

- The undersigned certifies that within the past 10 years the Bidder has NOT been the subject of a complaint or pending action in a legal administrative proceeding alleging that Bidder discriminated against its employees, subcontractors, vendors or suppliers.
  
- The undersigned certifies that within the past 10 years the Bidder has been the subject of a complaint or pending action in a legal administrative proceeding alleging that Bidder discriminated against its employees, subcontractors, vendors or suppliers. A description of the status or resolution of that complaint, including any remedial action taken and the applicable dates is as follows:

DATE OF CLAIM	LOCATION	DESCRIPTION OF CLAIM	LITIGATION (Y/N)	STATUS	RESOLUTION/REMEDIAL ACTION TAKEN

Contractor Name: Portillo Concrete, Inc.

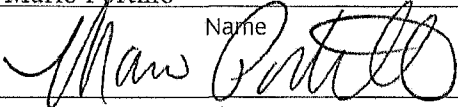
Certified By Mario Portillo Title President/CEO  
 Name  
 Signature Date 01/04/2017

USE ADDITIONAL FORMS AS NECESSARY

Bid Results for Project Sidewalk Replacement Group 1601 (K-17-1508-DBB-3)

Issued on 11/18/2016

Bid Due on January 4, 2017 2:00 PM (Pacific)

Exported on 01/05/2017

VendorID	Company Name	Address	City	ZipCode	Country	Contact	Phone	Fax	Email	Vendor Type
295276	<b>Portillo Concrete Inc</b>	3527 Citrus St	Lemon Grove	91945	United States	Mario Portillo	619-466-4639	619-466-4685	mportillo@portilloconcreteinc.com	LAT,MALE,PQUAL,DBE,HUBZ,MBE,CADIR,SDB,Local

Respondee	Respondee Title	Respondee Phone	Respondee Email
Mario Portillo	President/CEO	619-466-4639	mportillo@portilloconcreteinc.com

Bid Format	Submitted Date	Status	Confirmation #	Ranking
Electronic	January 4, 2017 1:52:11 PM (Pacific)	Submitted	95168	0

Attachments		
File Title	File Name	File Type
Contractor's Certification of Pending Actions	Contractor's Certifications of Pending Actions.pdf	General Attachments
Bid Bond	Bid Bond.pdf	Bid Bond

Line Items								
Item Num	Section	Item Code	Description	Unit of Measure	Quantity	Unit Price	Line Total	Reference
1	Main Bid	524126	Bonds (Payment and Performance)	LS	1	\$10,000.00	\$10,000.00	2-4.1
2	Main Bid	237310	Traffic Control	LS	1	\$50,000.00	\$50,000.00	601-6
3	Main Bid		Field Orders - (EOC Type II)	AL	1	\$35,000.00	\$35,000.00	9-3.5
4	Main Bid	238990	Remove and Replace Miscellaneous Hardscape with Topsoil	SF	1408	\$10.00	\$14,080.00	801-9
5	Main Bid	237310	Contractor Date Stamps and Impressions	EA	10	\$200.00	\$2,000.00	303-5.9
6	Main Bid	237310	Remove and Replace Curb and Gutter	LF	881	\$45.00	\$39,645.00	303-5.9
7	Main Bid	237310	Residential Concrete Driveway	SF	953	\$12.00	\$11,436.00	303-5.9
8	Main Bid	237310	Remove and Replace Existing Sidewalk	SF	54108	\$8.30	\$449,096.40	303-5.9
9	Main Bid	237310	Curb Ramp Type C1 or C2 with Detectable Warning Tiles	EA	1	\$4,000.00	\$4,000.00	303-5.10.2
10	Main Bid	237310	Curb Ramp Type A or B with Detectable Warning Tiles	EA	9	\$3,000.00	\$27,000.00	303-5.10.2
11	Main Bid	237310	Curb Ramp (Type D) with Detectable Warning Tiles	EA	5	\$2,500.00	\$12,500.00	303-5.10.2

Line Items								
Item Num	Section	Item Code	Description	Unit of Measure	Quantity	Unit Price	Line Total	Reference
12	Main Bid	238910	Tree Removal	EA	39	\$800.00	\$31,200.00	300-1.4
13	Main Bid	237310	Asphalt Concrete	TON	10	\$300.00	\$3,000.00	302-5.9
14	Main Bid	561730	Tree Planting (15 Gallon)	EA	42	\$750.00	\$31,500.00	801-9
15	Main Bid	561730	Tree Trimming	EA	5	\$600.00	\$3,000.00	801-9
16	Main Bid	561730	Root Pruning and Root Control Barrier (15 FT Segment)	EA	153	\$600.00	\$91,800.00	801-9
17	Main Bid	237110	Meter Box	EA	30	\$500.00	\$15,000.00	306-15.8
18	Main Bid	541330	Water Pollution Control Plan Development	LS	1	\$1,000.00	\$1,000.00	7-8.6.4.2
19	Main Bid	237990	Water Pollution Control Plan Implementation	LS	1	\$5,000.00	\$5,000.00	7-8.6.4.2
<b>Subtotal</b>							<b>\$836,257.40</b>	
<b>Total</b>							<b>\$836,257.40</b>	

Subcontractors									
Name	Description	License Num	Amount	Type	DIR #	Address	City	ZipCode	Country
Terra West, Inc	SLBE - WPCP	44127	\$550.00	DBE,ELBE	1000007319	1061 Tierra del Rey, suite 204	Chu	91910	United States
SASC Bonds	ELBE - BONDING	0	\$9,000.00		ELBE	5360 Jackson Dr. Ste. 108	La Mesa	91942	United States
Western Gardens Landscaping, Inc.	SLBE - LANDSCAPING	662550	\$119,059.00	PQUAL,SLBE,CAD IR	1000004289	4616 Pannonia Rd.	Carlsbad	92008	United States
RAT Sand and Materials	ELBE - WASTE TREATMENT AND DISPOSAL	562219	\$110,000.00	ELBE	562219	841 Turquoise Street, Suite F-506	San Diego	92109	United States

<b>Prime Self-Performance</b>
72.54%