

City of San Diego

CONTRACTOR'S NAME: 3-D Enterprises, Inc.

ADDRESS: 3665 Ruffin Road, Suite 103, San Diego, CA 92123

TELEPHONE NO.: 858-530-2202

CITY CONTACT: Rosa Isela Riego, Senior Contract Specialist, Email: RRiego@sanidiego.gov.

Phone No. (619) 533-3426

Carlos Rios



CONTRACT

Walkway at Marie Widman Memorial Park

CONTRACT NO.: M-25-0090

SAP NO. (WBS/IO): 12000549

THIS CONTRACT WILL BE SUBJECT TO THE FOLLOWING:

- PREVAILING WAGE RATES

TABLE OF CONTENTS

SECTION.....	PAGE
1. GENERAL CONDITIONS	3-7
2. LABOR AND MATERIALMEN'S BOND.....	8-9
3. ATTACHMENTS.....	10
a. SCOPE OF WORK	11-12
b. INTENTIONALLY LEFT BLANK.....	13
c. EQUAL OPPORTUNITY CONTRACTING PROGRAM	14-24
d. PREVAILING WAGES	25-29
e. SUPPLEMENTARY SPECIAL PROVISIONS	30-35
f. IN-USE OFF-ROAD DIESEL FUELED FLEET REGULATION (OFF-ROAD REGULATION) COMPLIANCE	36-39
g. CONTRACT AGREEMENT	40-42
4. CERTIFICATIONS AND FORMS	43-58

GENERAL CONDITIONS

1. **SUMMARY OF WORK:** Minor Construction services for Marie Widman Memorial Park. For additional information refer to Attachment A.
2. **CONSTRUCTION COST:** This contract is for a Lump Sum as set forth herein. The contract price for this project is \$52,600.00.
3. **PREVAILING WAGE RATES APPLY TO THIS CONTRACT:** Refer to Attachment D.
4. **LICENSE REQUIREMENT:** The City has determined that the following licensing classification(s) are required for this contract: A
5. **PREQUALIFICATION OF CONTRACTORS:** Contractors providing construction services to the City must be pre-qualified for the total amount proposed, including all alternate items.
6. **AWARD PROCESS:**
 - 6.1. Each signed quote shall constitute a firm offer which may be accepted by the City.
 - 6.2. The City may award the contract to the contractor with the written price quotation offering the best value to the City, considering factors such as price, unit cost, life cycle cost, economic cost analysis, operating efficiency, warranty and quality, compatibility with existing equipment, maintenance costs, experience and qualification of the contractor, when the contractor can start and complete the project, and any additional factors deemed relevant.
 - 6.3. The City of San Diego will not discriminate in the award of contracts with regard to race, religion creed, color, national origin, ancestry, physical handicap, marital status, sex or age.
 - 6.4. The award of this contract is contingent upon the Contractor's compliance with all conditions of this contract, including submission and acceptance of bonds and compliant insurance.
 - 6.5. This contract will be deemed executed and effective only upon the signing of the contract by the Mayor or his designee and approval as to form by the City Attorney's Office.
7. **ELECTRONIC QUOTE SUBMISSIONS CARRY FULL FORCE AND EFFECT**
 - 7.1. The Contractor, by submitting its quote, agrees to and certifies under penalty of perjury under the laws of the State of California, that the certification, forms and affidavits submitted pursuant to this contract are true and correct.
 - 7.2. The Contractor agrees to the construction of the project as described in Attachment "A-Scope of Work" for the City of San Diego, in accordance with the requirements set forth herein for the electronically submitted prices. The Contractor guarantees

the quoted price for a period of 120 days from the date the quote was submitted to the City. The duration of the quoted guarantee shall be extended by the number of days required for the City to obtain all items from the Contractor necessary to fulfill all conditions precedent.

8. QUOTES ARE PUBLIC RECORDS: Upon receipt by the City, Quotes shall become public records subject to public disclosure. It is the responsibility of the respondent to clearly identify any confidential, proprietary, trade secret or otherwise legally privileged information contained within the quote. General references to sections of the California Public Records Act (PRA) will not suffice. If the Contractor does not provide applicable case law that clearly establishes that the requested information is exempt from the disclosure requirements of the PRA, the City shall be free to release the information when required in accordance with the PRA, pursuant to any other applicable law, or by order of any court or government agency, and the Contractor will hold the City harmless for release of this information.

9. CONTRACTOR REGISTRATION AND ELECTRONIC REPORTING SYSTEM: Prior to the Award of this Contract, you and your Subcontractors and Suppliers must register with the City’s web-based vendor registration and quote management system. For additional information go to:

<http://www.sandiego.gov/purchasing/bids-contracts/vendorreg.shtml>

10. PREVAILING WAGE RATES WILL APPLY: Refer to Attachment D.

11. INSURANCE REQUIREMENTS:

11.1. All certificates of insurance and endorsements required by the contract are to be provided upon issuance of the City’s Notice of Intent to Award (NOI) letter.

11.2. Refer to sections 5-4, “INSURANCE”, and 5-4.11, “WORKERS’ COMPENSATION INSURANCE AND EMPLOYERS LIABILITY INSURANCE” of the Supplementary Special Provisions (SSP) for the insurance requirements which must be met.

12. REFERENCE STANDARDS: Except as otherwise noted or specified, the Work shall be completed in accordance with the following standards:

Title	Edition	Document Number
Standard Specifications for Public Works Construction (“The GREENBOOK”) http://www.greenbookspecs.org/	2021	ECPI010122-01
City of San Diego Standard Specifications for Public Works Construction (“The WHITEBOOK”)* https://www.sandiego.gov/publicworks/edocref/greenbook	2021	ECPI010122-02

Title	Edition	Document Number
City of San Diego Standard Drawings* https://www.sandiego.gov/publicworks/edocref/standarddraw	2021	ECPI010122-03
Citywide Computer Aided Design and Drafting (CADD) Standards https://www.sandiego.gov/publicworks/edocref/drawings	2018	PWPI010119-04
California Department of Transportation (CALTRANS) Standard Specifications – https://dot.ca.gov/programs/design/ccs-standard-plans-and-standard-specifications	2023	ECPD092023-05
CALTRANS Standard Plans https://dot.ca.gov/programs/design/ccs-standard-plans-and-standard-specifications	2023	ECPD092023-06
California Manual on Uniform Traffic Control Devices Revision 65 (CA MUTCD Rev 6) https://dot.ca.gov/programs/safety-programs/camutcd/camutcd-files	2014	PWPI060121-10
<p>NOTE: *Available online under Engineering Documents and References at: http://www.sandiego.gov/publicworks/edocref/index.shtml</p> <p>*Electronic updates to the Standard Drawings may also be found in the link above.</p>		

13. CITY'S RIGHTS RESERVED: The City reserves the right to reject submitted quotes at its sole discretion and without liability. Costs incurred by the Contractor as a result of preparing quotes shall be the sole responsibility of each Contractor. The Request for Quotes creates or imposes no obligation upon the City to enter a contract.

14. SUBCONTRACTOR INFORMATION:

14.1. LISTING OF SUBCONTRACTORS. In accordance with the requirements provided in the "Subletting and Subcontracting Fair Practices Act" of the California Public Contract Code, the Contractor shall provide the **NAME** and **ADDRESS** of each Subcontractor who will perform work, labor, render services or who specially fabricates and installs a portion [type] of the work or improvement, in an amount in excess of 0.5% of the Contractor's total Quote. The Contractor shall also state within the description, whether the subcontractor is a **CONSTRUCTOR**, **CONSULTANT** or **SUPPLIER**. The Contractor shall state the **DIR REGISTRATION NUMBER** for all subcontractors and shall further state within the description, the **PORTION** of the work which will be performed by each subcontractor under this Contract. The Contractor shall list only one Subcontractor for each portion of the Work. The **DOLLAR VALUE** of the total Quote to be performed shall be stated for all subcontractors listed. Failure to comply with this requirement may result in the Quote being rejected as **non-responsive** and ineligible for award. The Contractor's attention is directed to the Special Provisions - General; Paragraph 3-

2, "Self-Performance", which stipulates the percent of the Work to be performed with the Contractors' own forces.

- 14.2.** Additionally, pursuant to California Senate Bill 96 and in accordance with the requirements of Labor Code sections 1771.1 and 1725.5, by submitting a quote or proposal to the City, Contractor is certifying that he or she has verified that all subcontractors used on this public work project are registered with the California Department of Industrial Relations (DIR). **The Contractor shall provide the name, address, license number, DIR registration number of any Subcontractor - regardless of tier - who will perform work, labor, render services or specially fabricate and install the type of the work or improvement pursuant to the contract.**
- 15. SAN DIEGO BUSINESS TAX CERTIFICATE:** The Contractor and Subcontractors, not already having a City of San Diego Business Tax Certificate for the work contemplated shall secure the appropriate certificate from the City Treasurer, Civic Center Plaza, First floor and submit to the Contract Specialist upon request or as specified in the Contract Documents. Tax Identification numbers for both the Contractor and the listed Subcontractors must be submitted on the City provided forms within these documents.
- 16. EXAMINATION OF PLANS, SPECIFICATIONS, AND SITE OF WORK:** The Contractor shall examine carefully the Project Site, the Plans and Specifications, other materials as described in the Special Provisions, Section 2-7, and the proposal forms (e.g., Bidding Documents). The submission of a Quote shall be conclusive evidence that the Contractor has investigated and is satisfied as to the conditions to be encountered, as to the character, quality, and scope of Work, the quantities of materials to be furnished, and as to the requirements of the Bidding Documents Proposal, Plans, and Specifications.
- 17. CITY STANDARD PROVISIONS:** This contract is subject to the following standard provisions. See The WHITEBOOK for details.
- 17.1.** The City of San Diego Resolution No. R-277952 adopted on May 20, 1991 for a Drug-Free Workplace.
- 17.2.** The City of San Diego Resolution No. R-282153 adopted on June 14, 1993 related to the Americans with Disabilities Act.
- 17.3.** The City of San Diego Municipal Code §22.3004 for Contractor Standards.
- 17.4.** The City of San Diego's Labor Compliance Program and the State of California Labor Code §§1771.5(b) and 1776.
- 17.5.** Sections 1777.5, 1777.6, and 1777.7 of the State of California Labor Code concerning the employment of apprentices by contractors and subcontractors performing public works contracts.

- 17.6.** The City's Equal Benefits Ordinance (EBO), Chapter 2, Article 2, Division 43 of The San Diego Municipal Code (SDMC).
- 17.7.** The City's Information Security Policy (ISP) as defined in the City's Administrative Regulation 90.63.

Bond No.: 1016759

Premium: \$473.00

Premium is for contract term and subject to adjustment based on final contract price.

LABOR AND MATERIALMEN'S BOND

LABOR AND MATERIALMEN'S BOND:

3-D Enterprises, Incorporated, a corporation, as principal, and The Hanover Insurance Company, a corporation authorized to do business in the State of California, as Surety, hereby obligate themselves, their successors and assigns, jointly and severally, to The City of San Diego a municipal corporation in the sum of **Fifty Two Thousand Six Hundred Dollars and Zero Cents (\$52,600.00)** for the benefit of laborers and materialmen designated below.

Conditions:

If the Principal shall promptly pay all persons, firms and corporations furnishing materials for or performing labor in the execution of this contract, and shall pay all amounts due under the California Unemployment Insurance Act then the obligation herein with respect to laborers and materialmen shall be void; otherwise it shall remain in full force.

The obligation herein with respect to laborers and materialmen shall inure to the benefit of all persons, firms and corporations entitled to file claims under the provisions of Article 2. Claimants, (iii) public works of Improvement commencing with Civil Code Section 9100 of the Civil Code of the State of California.

Changes in the terms of the annexed contract or specifications accompanying same or referred to therein shall not affect the Surety's obligation on this bond, and the Surety hereby waives notice of same.

The Surety shall pay reasonable attorney's fees should suit be brought to enforce the provisions of this bond.

LABOR AND MATERIALMEN'S BOND (continued)

CONTRACTOR 3-D Enterprises, Incorporated

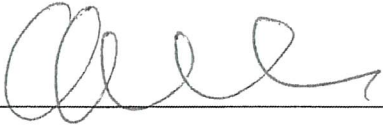
By: 

Print Name: Shahrokh Elibu

Date: 02/26/25

THE CITY OF SAN DIEGO

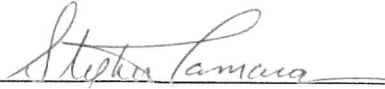
By: 

Print Name: Stephen Samara
Principal Contract Specialist
Purchasing & Contracting Department

Date: 2/27/2025

SURETY The Hanover Insurance Company

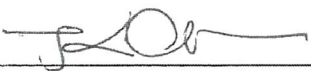
By: 

Print Name: Kim Truong
Attorney-In-Fact

Date: February 25, 2025

APPROVED AS TO FORM

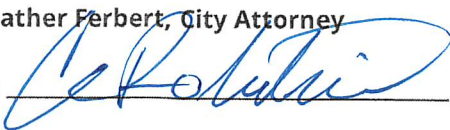
Heather Ferbert, City Attorney
By: 

Print Name: Alma Robbins
Deputy City Attorney

Date: 3/10/25

5 Hutton Centre Dr. Suite 1060, Santa Ana, CA 92707
Local Address of Surety

858-530-2202
Local Phone Number of Surety

\$473.00 Premium is for contract term and subject to adjustment based on final contract price.
Premium

1016759
Bond Number

ALL- PURPOSE CERTIFICATE OF ACKNOWLEDGMENT

A notary public or other officer completing this certificate verifies only the identity of the individual who signed the document to which this certificate is attached, and not the truthfulness, accuracy, or validity of that document.

State of California }

County of San Diego }

On February 25, 2025 before me, Audrey Rodriguez, Notary Public
(Here insert name and title of the officer)

personally appeared Kim Truong,
 who proved to me on the basis of satisfactory evidence to be the person(s) whose name(s) is/are subscribed to the within instrument and acknowledged to me that he/she/they executed the same in his/her/their authorized capacity(ies), and that by his/her/their signature(s) on the instrument the person(s), or the entity upon behalf of which the person(s) acted, executed the instrument.

I certify under PENALTY OF PERJURY under the laws of the State of California that the foregoing paragraph is true and correct.

WITNESS my hand and official seal.

Audrey Rodriguez
 Notary Public Signature

(Notary Public Seal)

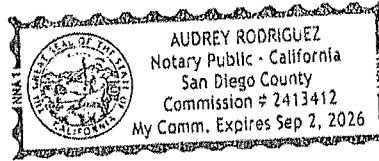

ADDITIONAL OPTIONAL INFORMATION

DESCRIPTION OF THE ATTACHED DOCUMENT

(Title or description of attached document)

(Title or description of attached document continued)

Number of Pages _____ Document Date _____

CAPACITY CLAIMED BY THE SIGNER

- Individual (s)
- Corporate Officer
- _____
(Title)
- Partner(s)
- Attorney-in-Fact
- Trustee(s)
- Other _____

INSTRUCTIONS FOR COMPLETING THIS FORM

This form complies with current California statutes regarding notary wording and, if needed, should be completed and attached to the document. Acknowledgments from other states may be completed for documents being sent to that state so long as the wording does not require the California notary to violate California notary law.

- State and County information must be the State and County where the document signer(s) personally appeared before the notary public for acknowledgment.
- Date of notarization must be the date that the signer(s) personally appeared which must also be the same date the acknowledgment is completed.
- The notary public must print his or her name as it appears within his or her commission followed by a comma and then your title (notary public).
- Print the name(s) of document signer(s) who personally appear at the time of notarization.
- Indicate the correct singular or plural forms by crossing off incorrect forms (i.e. he/she/they- is /are) or circling the correct forms. Failure to correctly indicate this information may lead to rejection of document recording.
- The notary seal impression must be clear and photographically reproducible. Impression must not cover text or lines. If seal impression smudges, re-seal if a sufficient area permits, otherwise complete a different acknowledgment form.
- Signature of the notary public must match the signature on file with the office of the county clerk.
 - ❖ Additional information is not required but could help to ensure this acknowledgment is not misused or attached to a different document.
 - ❖ Indicate title or type of attached document, number of pages and date.
 - ❖ Indicate the capacity claimed by the signer. If the claimed capacity is a corporate officer, indicate the title (i.e. CEO, CFO, Secretary).
- Securely attach this document to the signed document with a staple.

THE HANOVER INSURANCE COMPANY
MASSACHUSETTS BAY INSURANCE COMPANY
CITIZENS INSURANCE COMPANY OF AMERICA

POWER OF ATTORNEY

THIS Power of Attorney limits the acts of those named herein, and they have no authority to bind the Company except in the manner and to the extent herein stated.

KNOW ALL PERSONS BY THESE PRESENTS:

That THE HANOVER INSURANCE COMPANY and MASSACHUSETTS BAY INSURANCE COMPANY, both being corporations organized and existing under the laws of the State of New Hampshire, and CITIZENS INSURANCE COMPANY OF AMERICA, a corporation organized and existing under the laws of the State of Michigan, (hereinafter individually and collectively the "Company") does hereby constitute and appoint,

Michael Thomas, Audrey Rodriguez, and/or Kim Truong

Of Venbrook Insurance Services of Del Mar, CA each individually, if there be more than one named, as its true and lawful attorney(s)-in-fact to sign, execute, seal, acknowledge and deliver for, and on its behalf, and as its act and deed any place within the United States, any and all surety bonds, recognizances, undertakings, or other surety obligations. The execution of such surety bonds, recognizances, undertakings or surety obligations, in pursuance of these presents, shall be as binding upon the Company as if they had been duly signed by the president and attested by the secretary of the Company, in their own proper persons. Provided however, that this power of attorney limits the acts of those named herein; and they have no authority to bind the Company except in the manner stated and to the extent of any limitation stated below:

Any such obligations in the United States, not to exceed Thirty Million and No/100 (\$30,000,000) in any single instance

That this power is made and executed pursuant to the authority of the following Resolutions passed by the Board of Directors of said Company, and said Resolutions remain in full force and effect:

RESOLVED: That the President or any Vice President, in conjunction with any Vice President, be and they hereby are authorized and empowered to appoint Attorneys-in-fact of the Company, in its name and as it acts, to execute and acknowledge for and on its behalf as surety, any and all bonds, recognizances, contracts of indemnity, waivers of citation and all other writings obligatory in the nature thereof, with power to attach thereto the seal of the Company. Any such writings so executed by such Attorneys-in-fact shall be binding upon the Company as if they had been duly executed and acknowledged by the regularly elected officers of the Company in their own proper persons.

RESOLVED: That any and all Powers of Attorney and Certified Copies of such Powers of Attorney and certification in respect thereto, granted and executed by the President or Vice President in conjunction with any Vice President of the Company, shall be binding on the Company to the same extent as if all signatures therein were manually affixed, even though one or more of any such signatures thereon may be facsimile. (Adopted October 7, 1981 – The Hanover Insurance Company; Adopted April 14, 1982 – Massachusetts Bay Insurance Company; Adopted September 7, 2001 – Citizens Insurance Company of America and affirmed by each Company on March 24, 2014)

IN WITNESS WHEREOF, THE HANOVER INSURANCE COMPANY, MASSACHUSETTS BAY INSURANCE COMPANY and CITIZENS INSURANCE COMPANY OF AMERICA have caused these presents to be sealed with their respective corporate seals, duly attested by two Vice Presidents, this 31st day of July, 2023



The Hanover Insurance Company
Massachusetts Bay Insurance Company
Citizens Insurance Company of America

James H. Kawlecki
James H. Kawlecki, Vice President

The Hanover Insurance Company
Massachusetts Bay Insurance Company
Citizens Insurance Company of America

Joellen M. Mendoza
Joellen M. Mendoza, Vice President

STATE OF CONNECTICUT)
COUNTY OF HARTFORD) ss.

On this 31st day of July 2023 before me came the above named Executive Vice President and Vice President of The Hanover Insurance Company, Massachusetts Bay Insurance Company and Citizens Insurance Company of America, to me personally known to be the individuals and officers described herein, and acknowledged that the seals affixed to the preceding instrument are the corporate seals of The Hanover Insurance Company, Massachusetts Bay Insurance Company and Citizens Insurance Company of America, respectively, and that the said corporate seals and their signatures as officers were duly affixed and subscribed to said instrument by the authority and direction of said Corporations.

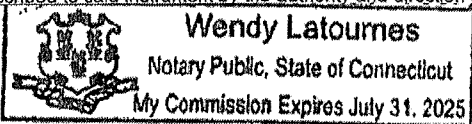

Wendy Latournes
Wendy Latournes, Notary Public
My commission expires July 31, 2025

I, the undersigned Vice President of The Hanover Insurance Company, Massachusetts Bay Insurance Company and Citizens Insurance Company of America, hereby certify that the above and foregoing is a full, true and correct copy of the Original Power of Attorney issued by said Companies, and do hereby further certify that the said Powers of Attorney are still in force and effect.

GIVEN under my hand and the seals of said Companies, at Worcester, Massachusetts, this 25th day of February 2025.

CERTIFIED COPY

The Hanover Insurance Company
Massachusetts Bay Insurance Company
Citizens Insurance Company of America

John Rowedder
John Rowedder, Vice President

ATTACHMENTS

ATTACHMENT A

SCOPE OF WORK

SCOPE OF WORK

1. **SCOPE OF WORK:** Construct new compliant walkway per provided plan page. General conditions, clear and grub, grade per design, form walkway and mow curb on native material and pour and finish concrete walkway.
 - 1.1. The Work shall be performed in accordance with:
 - 1.1.1. The Request for Quotes.
2. **LOCATION OF WORK: The location of the Work is as follows:**

Marie Widman Neighborhood Park – 449 Ritchey St., San Diego, CA 92114
3. **CONTRACT TIME:** The Contract Time for completion of the Work, shall be **30 Working Days**.

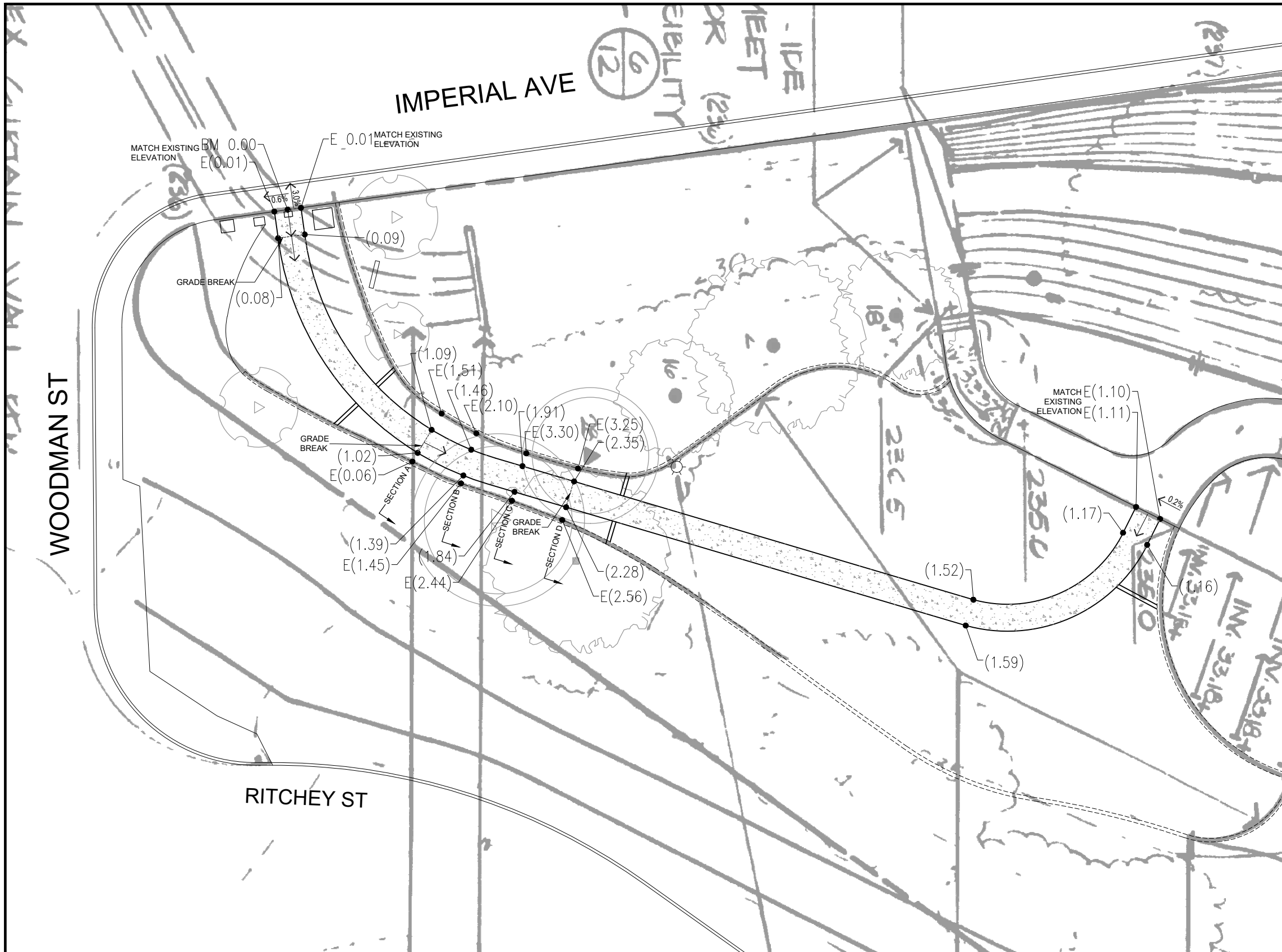

GRADING NOTES

- PRIOR TO CONSTRUCTION OR STAGING OF MATERIALS AND EQUIPMENT:
 - COORDINATE WITH CITY REPRESENTATIVE TO ADJUST EXISTING IRRIGATION AROUND WALKWAY. CONTRACTOR SHALL CUT AND CAP LINES AND REMOVE IRRIGATION AS NEEDED FOR SCOPE OF WORK. CITY SHALL MAKE REPAIRS TO IRRIGATION.
 - ESTABLISH TREE PROTECTION ZONE WITH P&R ARBORIST PER WHITEBOOK 400-3.3.
- CONCRETE PAVING SHALL HAVE FINISHED GRADES SMOOTHED TO ELIMINATE PUDDLING OR STANDING WATER. ALL FINISH SURFACES SHALL MAINTAIN A 0.5% MINIMUM SLOPE INTO PLANTER AREAS, SHALL HAVE A MAXIMUM CROSS SLOPE OF 1.5%, AND SHALL HAVE A MAXIMUM LONGITUDINAL SLOPE OF 4.5%. CONTRACTOR SHALL NOTIFY CITY REPRESENTATIVE OF ANY ISSUES WITH MEETING THESE REQUIREMENTS.
- ANY PROPOSED WORK THAT IS INCONSISTENT WITH COMMON, SAFE CONSTRUCTION PRACTICES SHALL BE BROUGHT TO THE ATTENTION OF THE CITY REPRESENTATIVE PRIOR TO COMMENCING WITH CONSTRUCTION.
- CONTRACTOR SHALL VISIT SITE AND VERIFY ALL FIELD CONDITIONS PRIOR TO BEGINNING CONSTRUCTION.
- CONTRACTOR SHALL DETERMINE THE LOCATION AND DEPTH OF ALL SITE UTILITIES PRIOR TO CONSTRUCTION. NOTIFY CITY REPRESENTATIVE OF ANY DISCREPANCIES IMMEDIATELY.

MARIE WIDMAN MEMORIAL PARK

NEW WALKWAY - GRADING PLAN

DATE: 09/25/2024

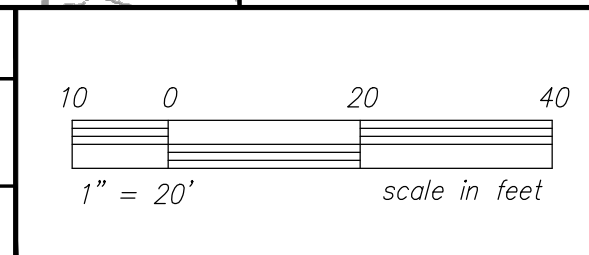

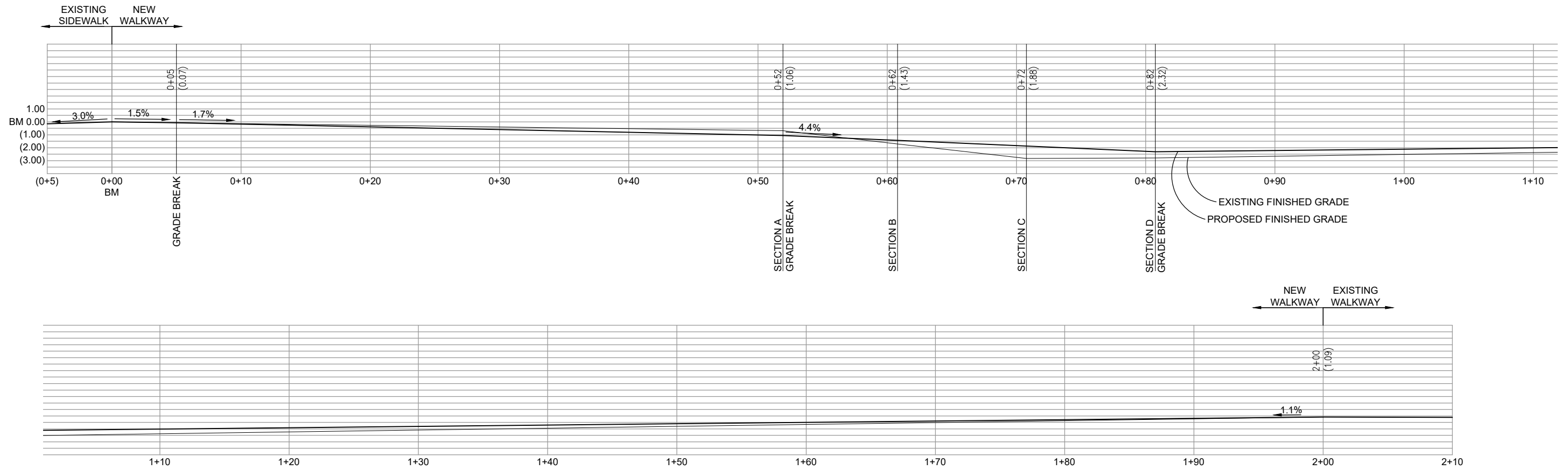

A WALKWAY PROFILE
SCALE: 1/8" = 1'-0"

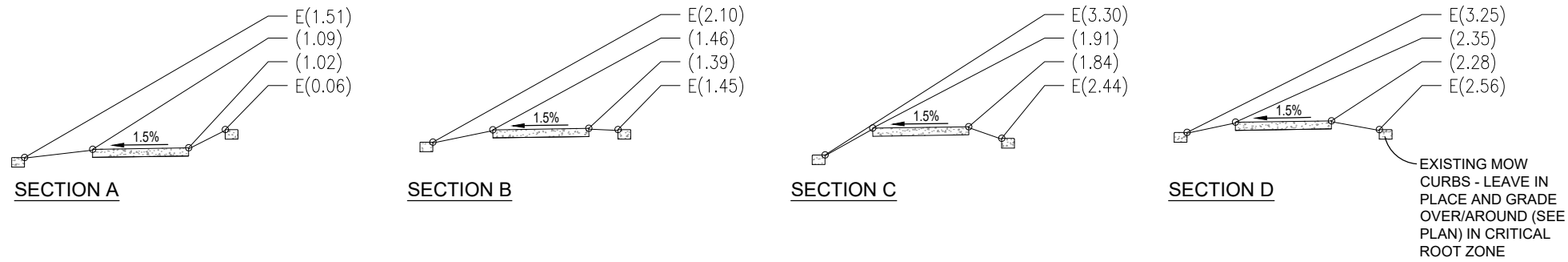

B WALKWAY SECTIONS
SCALE: 1/8" = 1'-0"

MARIE WIDMAN MEMORIAL PARK

NEW WALKWAY - GRADING SECTIONS AND PROFILES

City of San Diego
Parks & Recreation Department

DATE: 09/25/2024

PAGE 2 of 4

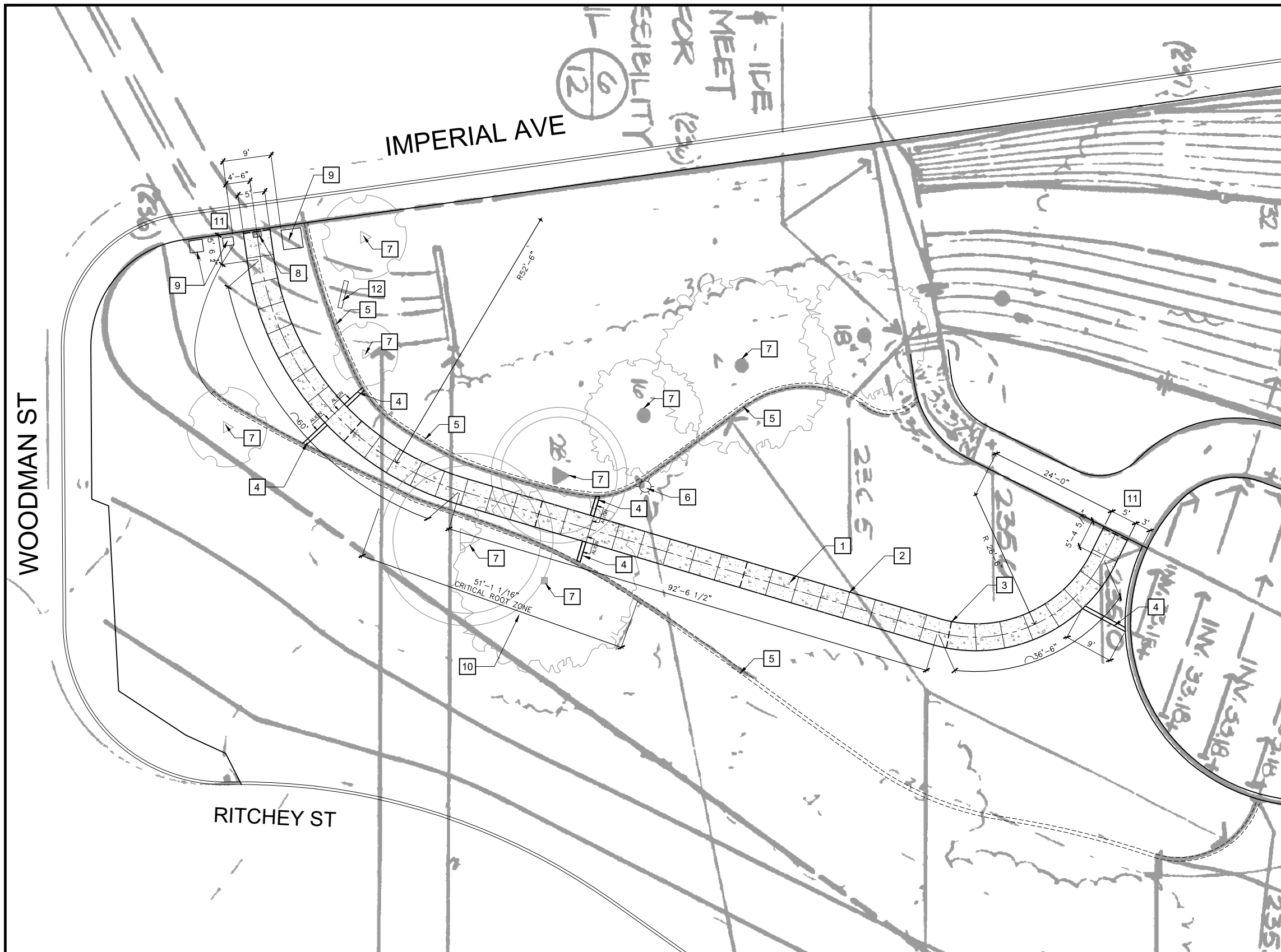

KEYNOTES		DETAIL
1	PEDESTRIAN CONCRETE PAVING - 5' WIDE, 5" THICKNESS. COLOR: STANDARD GRAY. FINISH: MEDIUM BROOM. PERPENDICULAR TO DIRECTION OF TRAVEL	A/4
2	CONCRETE CONTROL JOINT - TOOLED	B/4
3	CONCRETE EXPANSION JOINT; COLOR: MATCH PAVING	B&D/4
4	CONCRETE MOW CURB	SDL-103
5	EXISTING CONCRETE MOW CURB - TO REMAIN. PROTECT IN PLACE, TYP. MOWCURB WITHIN CRITICAL ROOT ZONE AREA CAN BE GRADED OVER.	
6	EXISTING SECURITY LIGHTING - PROTECT IN PLACE	
7	ALL EXISTING TREES TO BE PROTECTED IN PLACE. PRIOR TO CONSTRUCTION OR STAGING OF MATERIALS AND EQUIPMENT, ESTABLISH TREE PROTECTION ZONE WITH P&R ARBORIST PER WHITEBOOK 400-3.3.	WHITEBOOK 400-3.3
8	EXISTING ELECTRICAL PULL BOX TO BE REMOVED. REPLACE WITH NEW PULL BOX PER CITY STANDARD SET ON TOP OF EXISTING CONDUITS, AND SET IN NEW CONCRETE.	
9	EXISTING UTILITY APPURTENANCES TO REMAIN - PROTECT IN PLACE	
10	APPROXIMATE CRITICAL ROOT ZONE AREA - FULL EXTENT TO BE DETERMINED IN FIELD W/ P&R ARBORIST. NO HEAVY EQUIPMENT IN CRITICAL ROOT ZONE	C/4
11	EXISTING CONCRETE SIDEWALK OR WALKWAY TO REMAIN - PROTECT IN PLACE. CONNECT EXISTING TO NEW CONCRETE WALKWAY PER DETAIL D/4.	D/4
12	EXISTING MONUMENT SIGN TO REMAIN - PROTECT IN PLACE.	D/4

- CONSTRUCTION NOTES**
- PRIOR TO CONSTRUCTION OR STAGING OF MATERIALS AND EQUIPMENT:
 - COORDINATE WITH CITY REPRESENTATIVE TO ADJUST EXISTING IRRIGATION AROUND WALKWAY. CONTRACTOR SHALL CUT AND CAP LINES AND REMOVE IRRIGATION AS NEEDED FOR SCOPE OF WORK. CITY SHALL MAKE REPAIRS TO IRRIGATION.
 - ESTABLISH TREE PROTECTION ZONE WITH P&R ARBORIST PER WHITEBOOK 400-3.3.
 - UNLESS SPECIFIED OTHERWISE, LANDSCAPE CONSTRUCTION AND LAYOUT WORK INCLUDES, BUT IS NOT LIMITED TO THE LOCATION, PLACEMENT AND DETAILING OF THE PAVING.
 - DIMENSIONS INDICATED ON PLANS SHALL PREVAIL OVER PLAN SCALE. ALL ANGLES AND CONNECTIONS ARE (90) DEGREES UNLESS NOTED OTHERWISE.
 - EXPANSION JOINTS SHALL BE AS LOCATED ON THE PLANS AND WHERE CONCRETE MEETS EXISTING HARD SURFACES.
 - CONSTRUCT EXPANSION, WEAKENED-PLANE (CONTROL) AND CONSTRUCTION JOINTS IN ACCORDANCE WITH GREENBOOK, WHITEBOOK AND DETAILS.
 - CONCRETE PAVING SHALL HAVE FINISHED GRADES SMOOTHED TO ELIMINATE PUDDLING OR STANDING WATER. ALL FINISH SURFACES SHALL MAINTAIN A 0.5% MINIMUM SLOPE INTO PLANTER AREAS. SHALL HAVE A MAXIMUM CROSS SLOPE OF 1.5% AND SHALL HAVE A MAXIMUM LONGITUDINAL SLOPE OF 4.5%. CONTRACTOR SHALL NOTIFY CITY REPRESENTATIVE OF ANY ISSUES WITH MEETING THESE REQUIREMENTS.
 - SCORE JOINTS SHALL BE AS SHOWN ON THE PLANS OR SET ON TYPICAL ON CENTER SPACING AND ALIGN WITH EXISTING EDGES.
 - LAYOUT POINTS OF ALL RADIUS SHALL BE CONNECTED BY SMOOTH EVEN LINES TO CREATE THE CURVED CONFIGURATION AS SHOWN ON THE PLANS. NO DEVIATIONS FROM PLANS SHALL OCCUR WITHOUT APPROVAL OF THE CITY'S REPRESENTATIVE.
 - ANY PROPOSED WORK THAT IS INCONSISTENT WITH COMMON, SAFE CONSTRUCTION PRACTICES SHALL BE BROUGHT TO THE ATTENTION OF THE CITY REPRESENTATIVE PRIOR TO COMMENCING WITH CONSTRUCTION.
 - CONTRACTOR SHALL VISIT SITE AND VERIFY ALL FIELD CONDITIONS PRIOR TO BEGINNING CONSTRUCTION.
 - CONTRACTOR SHALL DETERMINE THE LOCATION AND DEPTH OF ALL SITE UTILITIES PRIOR TO CONSTRUCTION. NOTIFY CITY REPRESENTATIVE OF ANY DISCREPANCIES IMMEDIATELY.
 - CONTRACTOR SHALL CONSTRUCT ONE FOUR FOOT BY FOUR FOOT (4' X 4') MOCKUP FOR CONCRETE PAVING. MOCKUP SHALL INCLUDE APPROVED COLOR, FINISHES, AND PATTERNS AS INDICATED ON THE PLANS. CONCRETE MOCKUP SHALL INCLUDE EXPANSION JOINT AND CONTROL JOINT SAMPLES. IN THE EVENT MOCKUP IS DETERMINED TO BE UNACCEPTABLE, CONTRACTOR SHALL CONSTRUCT A NEW MOCKUP AS REQUIRED TO OBTAIN APPROVAL. APPROVED MOCKUP SHALL REMAIN ON-SITE AND BE PROTECTED FOR THE DURATION OF THE CONSTRUCTION PERIOD AND SERVE AS THE BENCHMARK FOR CONSTRUCTION OF THESE ELEMENTS.

MARIE WIDMAN MEMORIAL PARK
NEW WALKWAY - CONSTRUCTION PLAN

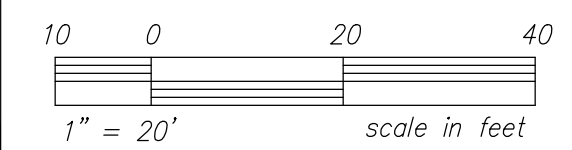

DATE: 09/25/2024

City of San Diego
 Parks & Recreation Department



NORTH

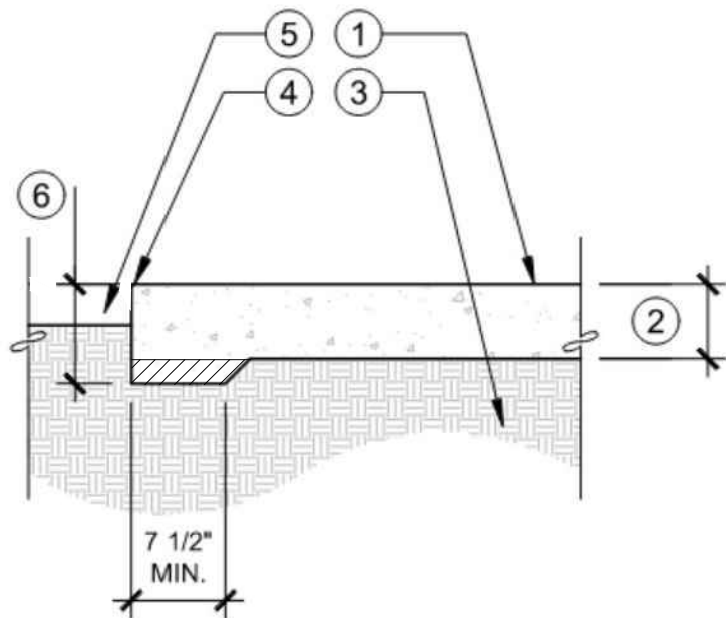

LEGEND

- ① CONCRETE PAVING- FINISH PER PLAN
- ② 5" MINIMUM THICKNESS CONCRETE PAVING
- ③ COMPACTED SUBGRADE AT 95% MIN. 12" DEPTH.
- ④ 1/4" RADIUS, TYP.
- ⑤ FINISH SURFACE 3" ABOVE GRADE AT PLANTER AREAS, 1/2" ABOVE GRADE AT TURF
- ⑥ THICKENED EDGE. 7-1/2" DEPTH - NOT APPLICABLE

NOTES:

- 1. SLOPE PAVING PER GRADING PLANS
- 2. CONSTRUCTION JOINTS PER PLANS
- 3. CONCRETE SHALL BE CLASS 560-C-3250 PSI - PROVIDE CONCRETE MIX DESIGN FOR APPROVAL.

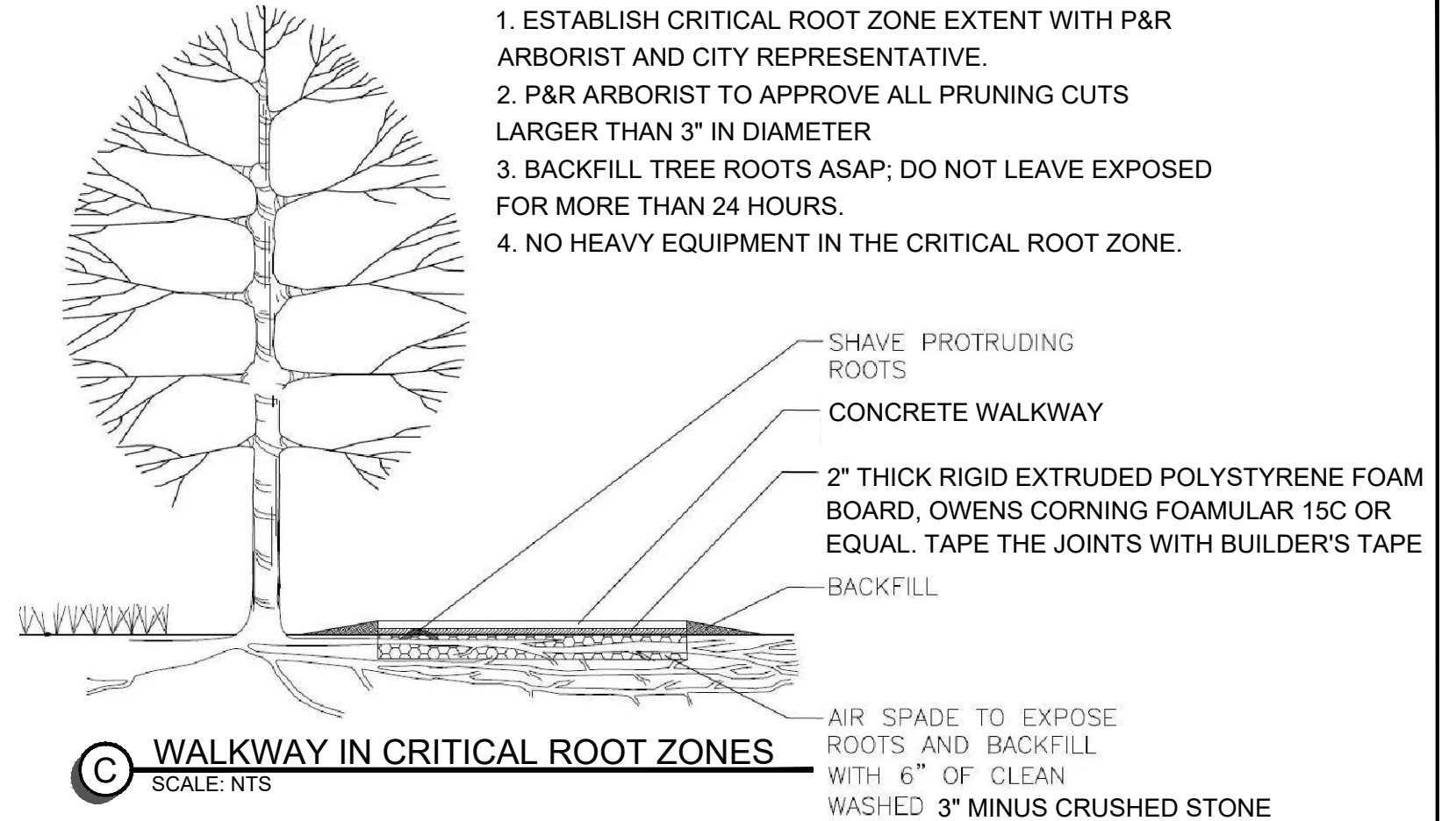

- 1. ESTABLISH CRITICAL ROOT ZONE EXTENT WITH P&R ARBORIST AND CITY REPRESENTATIVE.
- 2. P&R ARBORIST TO APPROVE ALL PRUNING CUTS LARGER THAN 3" IN DIAMETER
- 3. BACKFILL TREE ROOTS ASAP; DO NOT LEAVE EXPOSED FOR MORE THAN 24 HOURS.
- 4. NO HEAVY EQUIPMENT IN THE CRITICAL ROOT ZONE.

C WALKWAY IN CRITICAL ROOT ZONES
SCALE: NTS

A WALKWAY DETAIL
NOT TO SCALE

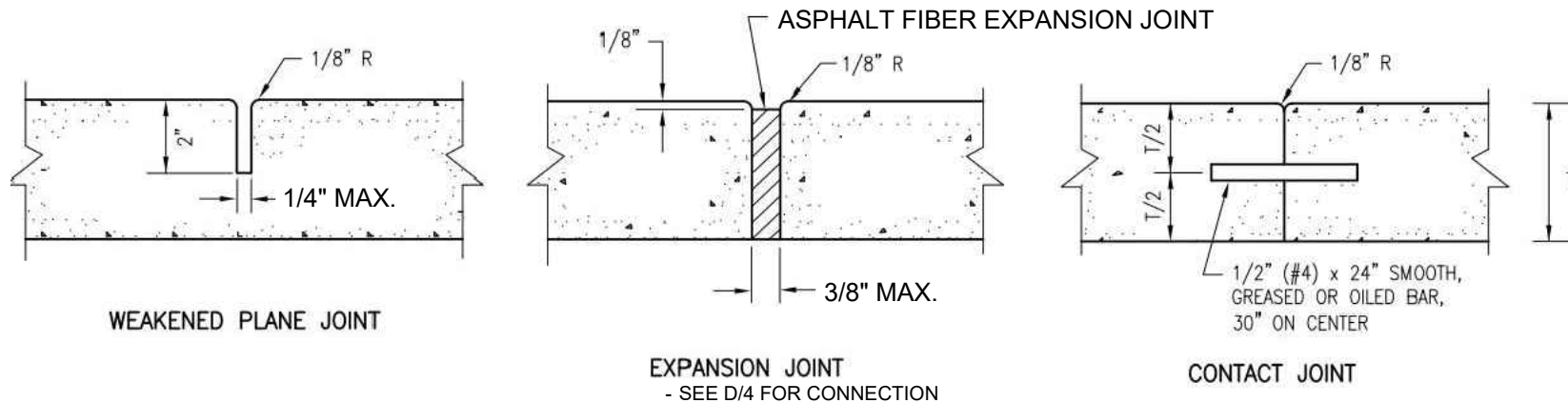

B CONSTRUCTION JOINTS
NOT TO SCALE

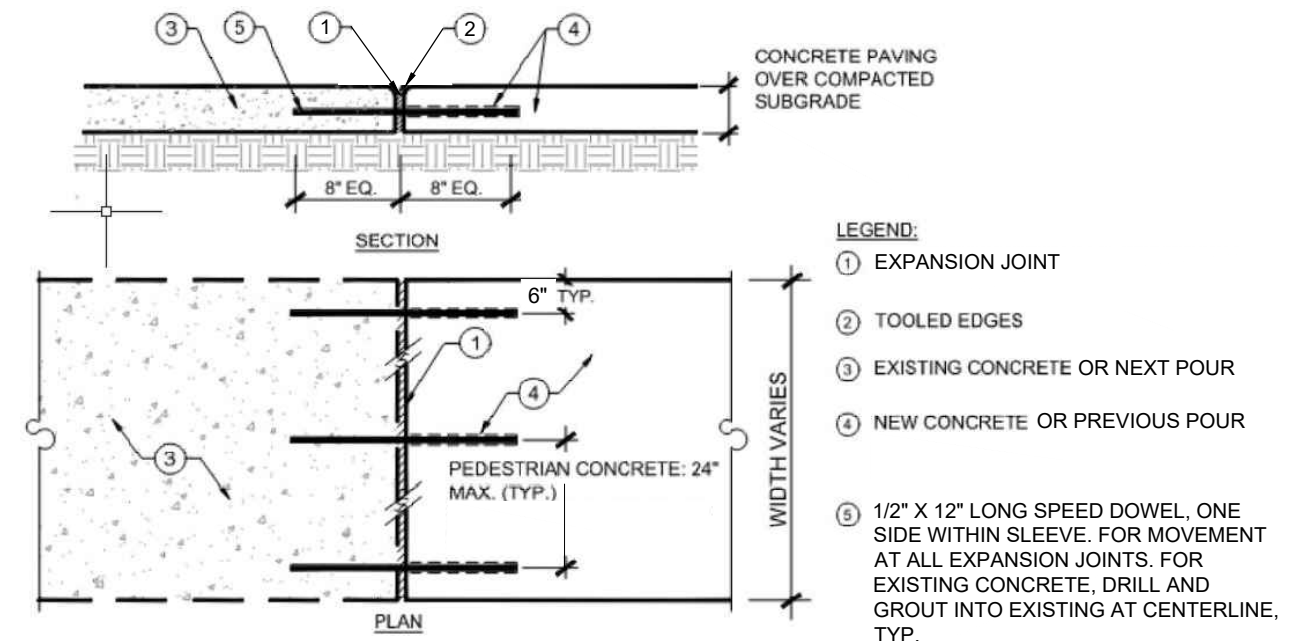

D CONCRETE PAVING CONNECTION
NOT TO SCALE

MARIE WIDMAN MEMORIAL PARK

NEW WALKWAY - CONSTRUCTION DETAILS

City of San Diego
Parks & Recreation Department

DATE: 09/25/2024

PAGE 4 of 4

ATTACHMENT B
INTENTIONALLY LEFT BLANK

ATTACHMENT C
EQUAL OPPORTUNITY CONTRACTING PROGRAM

EQUAL OPPORTUNITY CONTRACTING PROGRAM (EOCP)
SECTION A - GENERAL REQUIREMENTS

A. INTRODUCTION.

1. This document sets forth the following specifications:
 - a) The City's general EOCP requirements for all Construction Contracts.
 - b) Special Provisions for Contracts subject to SLBE and ELBE requirements only.
2. Additional requirements may apply for state or federally funded projects.
3. These requirements shall be included as Contract provisions for all Subcontracts.
4. The City specified forms, instructions, and guides are available for download from the EOCP's web site at: <http://www.sandiego.gov/eoc/forms/index.shtml>

B. GENERAL.

1. The City of San Diego promotes equal employment and subcontracting opportunities.
2. The City is committed to ensuring that taxpayer dollars spent on public Contracts are not paid to businesses that practice discrimination in employment or subcontracting.
3. The City encourages all companies seeking to do business with the City to share this commitment.

C. DEFINITIONS.

1. For the purpose of these requirements: Terms "Bid" and "Proposal", "Bidder" and "Proposer", "Subcontractor" and "Subconsultant", "Contractor" and "Consultant", "Contractor" and "Prime Contractor", "Consultant" and "Professional Service Provider", "Suppliers" and "Vendors", "Suppliers" and "Dealers", and "Suppliers" and "Manufacturers" may have been used interchangeably.
2. The following definitions apply:
 - a) **Emerging Business Enterprise (EBE)** - A for-profit business that is independently owned and operated; that is not a subsidiary or franchise of another business and whose gross annual receipts do not exceed the amount set by the City Manager and that meets all other criteria set forth in regulations implementing Municipal Code Chapter 2, Article 2, Division 36. The City Manager shall review the threshold amount for EBEs on an annual basis and adjust as necessary to reflect changes in the marketplace.
 - b) **Emerging Local Business Enterprise (ELBE)** - A Local Business

Enterprise that is also an Emerging Business Enterprise.

- c) **Minority Business Enterprise (MBE)** - A certified business that is at least fifty-one percent (51%) owned by one or more minority individuals, or, in the case of a publicly owned business at least fifty-one percent (51%) of the stock is owned by one or more minority individuals; and (2) whose daily business operations are managed and directed by one or more minorities owners. Minorities include the groups with the following ethnic origins: African, Asian Pacific, Asian Subcontinent, Hispanic, Native Alaskan, Native American, and Native Hawaiian.
- d) **Women Business Enterprise (WBE)** - A certified business that is at least fifty-one percent (51%) owned by a woman or women, or, in the case of a publicly owned business at least fifty-one percent (51%) of the stock is owned by one or more women; and (2) whose daily business operations are managed and directed by one or more women owners.
- e) **Disadvantaged Business Enterprise (DBE)** - a certified business that is at least fifty-one percent (51%) owned by socially and economically disadvantaged individuals, or, in the case of a publicly owned business at least fifty-one percent (51%) of the stock is owned by one or more socially and economically disadvantaged individuals; and (2) whose daily business operations are managed and directed by one or more socially and economically disadvantaged owners.
- f) **Disabled Veteran Business Enterprise (DVBE)** - A certified business that is at least fifty-one percent (51%) owned by one or more disabled veterans; and (2) business operations must be managed and controlled by one or more disabled veterans. Disabled Veteran is a veteran of the U.S. military, naval, or air service; the veteran must have a service-connected disability of at least 10% or more; and the veteran must reside in California.
- g) **Other Business Enterprise (OBE)** - Any business which does not otherwise qualify as a Minority, Woman, Disadvantaged, or Disabled Veteran Business Enterprise.
- h) **Small Business Enterprise (SBE)** - A for-profit business that is independently owned and operated; that is not a subsidiary or franchise of another business and whose gross annual receipts do not exceed the amount set by the City Manager and that meets all other criteria set forth in regulations implementing Municipal Code Chapter 2, Article 2, Division 36. The City Manager shall review the threshold amount for SBEs on an annual basis and adjust as necessary to reflect changes in the marketplace. A business certified as a Micro Business (MB) or a Disabled Veteran Business Enterprise (DVBE) by the State of California and that has provided proof of such certification to the City Manager shall be deemed to be an SBE.

- i) **Small Local Business Enterprise (SLBE)** - A Local Business Enterprise that is also a Small Business Enterprise.

D. CITY'S EQUAL OPPORTUNITY COMMITMENT.

1. Nondiscrimination in Contracting Ordinance.

- a) You, your Subcontractors, and Suppliers shall comply with the requirements of the City's Nondiscrimination in Contracting Ordinance, San Diego Municipal Code §§22.3501 through 22.3517.

You shall not discriminate on the basis of race, gender, gender expression, gender identity, religion, national origin, ethnicity, sexual orientation, age, or disability in the solicitation, selection, hiring, or treatment of subcontractors, vendors, or suppliers. You shall provide equal opportunity for Subcontractors to participate in subcontracting opportunities. You understand and agree that the violation of this clause shall be considered a material breach of the Contract and may result in Contract termination, debarment, or other sanctions.

You shall include the foregoing clause in all Contracts between you and your Subcontractors and Suppliers.

- b) **Disclosure of Discrimination Complaints.** As part of its Bid or Proposal, you shall provide to the City a list of all instances within the past 10 years where a complaint was filed or pending against you in a legal or administrative proceeding alleging that you discriminated against your employees, Subcontractors, vendors, or suppliers, and a description of the status or resolution of that complaint, including any remedial action taken.
- c) Upon the City's request, You agree to provide to the City, within 60 Calendar Days, a truthful and complete list of the names of all Subcontractors and Suppliers that you have used in the past 5 years on any of your Contracts that were undertaken within the San Diego County, including the total dollar amount paid by you for each Subcontract or supply Contract.
- d) You further agree to fully cooperate in any investigation conducted by the City pursuant to the City's Nondiscrimination in Contracting Ordinance, Municipal Code §§22.3501 through 22.3517. You understand and agree that violation of this clause shall be considered a material breach of the Contract and may result in remedies being ordered against you up to and including contract termination, debarment, and other sanctions for the violation of the provisions of the Nondiscrimination in Contracting Ordinance. You further understand and agree that the procedures, remedies, and sanctions provided for in the Nondiscrimination in Contracting Ordinance apply only to violations of the Ordinance.

E. EQUAL EMPLOYMENT OPPORTUNITY OUTREACH PROGRAM.

1. You, your Subcontractors, and Suppliers shall comply with the City's Equal Employment Opportunity Outreach Program, San Diego Municipal Code §§22.2701 through 22.2707.

You shall not discriminate against any employee or applicant for employment on any basis prohibited by law. You shall provide equal opportunity in all employment practices. You shall ensure that your Subcontractors comply with this program. Nothing in this section shall be interpreted to hold you liable for any discriminatory practices of your Subcontractors.

You shall include the foregoing clause in all Contracts between you and your Subcontractors and Suppliers.

2. If the Contract is competitively solicited, the selected Bidder shall submit a Work Force Report (Form BB05) within 10 Working Days after receipt by the Bidder to the City for approval as specified in the Notice of Intent to Award letter.
3. The selected Bidder shall submit an Equal Employment Opportunity Plan if a Work Force Report is submitted and if the City determines that there are under-representations when compared to County Labor Force Availability data.
4. If the selected Bidder submits an Equal Employment Opportunity Plan, it shall include the following assurances:
 - a) You shall maintain a working environment free of discrimination, harassment, intimidation, and coercion at all Sites and in all facilities at which your employees are assigned to Work.
 - b) You shall review your EEO Policy annually with all on-Site supervisors involved in employment decisions.
 - c) You shall disseminate and review your EEO Policy with all employees at least once a year, post the policy statement and EEO posters on all company bulletin boards and job sites, and document every dissemination, review, and posting with a written record to identify the time, place, employees present, subject matter, and disposition of meetings.
 - d) You shall review, at least annually, all supervisors' adherence to and performance under the EEO Policy and maintain written documentation of these reviews.
 - e) You shall discuss your EEO Policy Statement with Subcontractors with whom you anticipate doing business, including the EEO Policy Statement in your Subcontracts, and provide such documentation to the City upon request.

- f) You shall document and maintain a record of all Bid solicitations and outreach efforts to and from Subcontractors, contractor associations, and other business associations.
- g) You shall disseminate your EEO Policy externally through various media, including the media of people of color and women, in advertisements to recruit. Maintain files documenting these efforts and provide copies of these advertisements to the City upon request.
- h) You shall disseminate your EEO Policy to union and community organizations.
- i) You shall provide immediate written notification to the City when any union referral process has impeded your efforts to maintain your EEO Policy.
- j) You shall maintain a current list of recruitment sources, including those outreaching to people of color and women, and provide written notification of employment opportunities to these recruitment sources with a record of the organizations' responses.
- k) You shall maintain a current file of names, addresses and phone numbers of each walk-in applicant, including people of color and women, and referrals from unions, recruitment sources, or community organizations with a description of the employment action taken.
- l) You shall encourage all present employees, including people of color and women employees, to recruit others.
- m) You shall maintain all employment selection process information with records of all tests and other selection criteria.
- n) You shall develop and maintain documentation for on-the-job training opportunities, participate in training programs, or both for all of your employees, including people of color and women, and establish apprenticeship, trainee, and upgrade programs relevant to your employment needs.
- o) You shall conduct, at least annually, an inventory and evaluation of all employees for promotional opportunities and encourage all employees to seek and prepare appropriately for such opportunities.
- p) You shall ensure that the company's working environment and activities are non-segregated except for providing separate or single-user toilets and necessary changing facilities to assure privacy between the sexes.

F. SUBCONTRACTING.

1. The City encourages all eligible business enterprises to participate in City contracts as a Contractor, Subcontractor, and joint venture partner with you, your Subcontractors, or your Suppliers. You are encouraged to take positive

steps to diversify and expand your Subcontractor solicitation base and to offer subcontracting opportunities to all eligible business firms including SLBEs, ELBEs, MBEs, WBEs, DBEs, DVBEs, and OBEs.

2. For Subcontractor participation level requirements, see the Contract Documents where applicable.
3. For the purposes of achieving the mandatory Subcontractor participation percentages, City percentage calculations will not account for the following:
 - a) "Field Orders" and "City Contingency" Bid items.
 - b) Alternate Bid items.
 - c) Allowance Bid items designated as "EOC Type II".
4. Allowance Bid items designated as "EOC Type I" will be considered as part of the Base Bid and will be included in the percentage calculation.
5. Each joint venture partner shall be responsible for a clearly defined Scope of Work. In addition, an agreement shall be submitted and signed by all parties identifying the extent to which each joint venture partner shares in ownership, control, management, risk, and profits of the joint venture.

G. LISTS OF SUBCONTRACTORS AND SUPPLIERS.

1. You shall comply with the Subletting and Subcontracting Fair Practices Act, Public Contract Code §§4100 through 4113, inclusive.
2. You shall list all Subcontractors who will receive more than 0.5% of the total Bid amount or \$10,000, whichever is greater on the form provided in the Contract Documents (Subcontractors list).
3. The Subcontractors list shall include the Subcontractor's name, telephone number including area code, physical address, Scope of Work, the dollar amount of the proposed Subcontract, the California contractor license number, the Public Works contractor registration number issued pursuant to Section 1725.5 of the Labor Code, and the Subcontractor's certification status with the name of the certifying agency.
4. The listed Subcontractor shall be appropriately licensed pursuant to Contractor License Laws.
5. For Design-Build Contracts, refer to the RFQ and RFP for each Project or Task Order.

H. SUBCONTRACTOR AND SUPPLIER SUBSTITUTIONS.

1. Listed Subcontractors and Suppliers shall not be substituted without the Express authorization of the City or its duly authorized agent.
2. Request for Subcontractor or Supplier substitution shall be made in writing to Purchasing & Contracting Department, Public Works Division, Attention Contract Specialist, 1200 3rd Ave., Suite 200, MS56P, San Diego, CA 92101 with

a copy to the Engineer.

3. The request shall include a thorough explanation of the reason(s) for the substitution, including dollar amounts and a letter from each substituted Subcontractor or Supplier stating that they (the Subcontractors or Suppliers) release all interest in working on the Project and written confirmation from the new Subcontractor or Supplier stating that they agree to work on the Project along with the dollar value of the Work to be performed.
4. Written approval of the substitution request shall be received by you or from the City or its authorized officer prior to any unlisted Subcontractor or Supplier performing Work on the Project.
5. Substitution of Subcontractors and Suppliers without authorization shall subject you to those penalties set forth in Public Contract Code §4110.
6. Requests for Supplier substitution shall be made in writing at least 10 Days prior to the provision of materials, supplies, or services by the proposed Supplier and shall include proof of written notice to the originally listed Supplier of the proposed substitution.
7. A Contractor whose Bid is accepted shall not:
 - a) Substitute a person as Subcontractor or Supplier in place of the Subcontractor or Supplier listed in the original bid, except that the City, or it's duly authorized officer, may consent to the substitution of another person as a Subcontractor or Supplier in any of the following situations:
 - i. When the Subcontractor or Supplier listed in the Bid, after having a reasonable opportunity to do so, fails or refuses to execute a written Contract for the scope of work specified in the subcontractor's bid and at the price specified in the subcontractor's bid, when that written contract, based upon the general terms, conditions, plans, and specifications for the project involved or the terms of the subcontractor's written bid, is presented to the subcontractor by the prime contractor.
 - ii. When the listed Subcontractor or Supplier becomes insolvent or the subject of an order for relief in bankruptcy.
 - iii. When the listed Subcontractor or Supplier fails or refuses to perform his or her subcontract.
 - iv. When the listed Subcontractor fails or refuses to meet bond requirements as set forth in Public Contract Code §4108.
 - v. When you demonstrate to the City or it's duly authorized officer, subject to the provisions set forth in Public Contract Code §4107.5, that the name of the Subcontractor was listed as the result of an inadvertent clerical error.
 - vi. When the listed Subcontractor is not licensed pursuant to Contractor License Law.

- vii. When the City, or its duly authorized officer, determines that the Work performed by the listed Subcontractor or that the materials or supplies provided by the listed Supplier are substantially unsatisfactory and not in substantial accordance with the Plans and specifications or that the Subcontractor or Supplier is substantially delaying or disrupting the progress of the Work.
 - viii. When the listed Subcontractor is ineligible to work on a public works project pursuant to §§1777.1 or 1777.7 of the Labor Code.
 - ix. When the City or its duly authorized agent determines that the listed Subcontractor is not a responsible contractor.
- b) Permit a Contract to be voluntarily assigned or transferred or allow it to be performed by anyone other than the original Subcontractor, Supplier listed in the original Bid without the consent of the City, or its duly authorized officer.
 - c) Other than in the performance of "Change Orders" causing changes or deviations from the Contract, sublet or subcontract any portion of the Work, or contract for materials or supplies in excess of 0.5% of your total bid or \$10,000, whichever is greater, as to which his or her original Bid did not designate a Subcontractor or Supplier.
8. Following receipt of notice from you of the proposed substitution of a Subcontractor or Supplier, the listed Subcontractor or Supplier who has been so notified shall have 5 Working Days within which to submit written objections to the substitution to the Contract Specialist with a copy to the Engineer. Failure to file these written objections shall constitute the listed Subcontractor or Supplier's consent to the substitution. If written objections are filed, the City shall give notice in writing of at least 5 Working Days to the listed Subcontractor or Supplier of a hearing by the City on your request for substitution.

I. PROMPT PAYMENT.

- 1. You or your Subcontractors shall pay to any subcontractor, not later than 7 Calendar Days of receipt of each progress payment, unless otherwise agreed to in writing, the respective amounts allowed you on account of the Work performed by the Subcontractors, to the extent of each Subcontractor's interest therein. In cases of Subcontractor performance deficiencies, you shall make written notice of any withholding to the Subcontractor with a copy to the Contracts Specialist. Upon correction of the deficiency, you shall pay the Subcontractor the amount previously withheld within 14 Calendar Days after payment by the City.
- 2. Any violation of California Business and Professions Code, §7108.5 concerning prompt payment to Subcontractors shall subject the violating Contractor or Subcontractor to the penalties, sanctions, and other remedies of that section.

This requirement shall not be construed to limit or impair any contractual, administrative, or judicial remedies otherwise available to you or your Subcontractor in the event of a dispute involving late payment or nonpayment by the Prime Contractor, deficient subcontract performance, or noncompliance by a Subcontractor.

J. PROMPT PAYMENT OF FUNDS WITHHELD TO SUBCONTRACTORS.

1. The City will hold retention from you and will make prompt and regular incremental acceptances of portions, as determined by the Engineer, of the Work and pay retention to you based on these acceptances.
2. You or your Subcontractors shall return all monies withheld in retention from a Subcontractor within 30 Calendar Days after receiving payment for Work satisfactorily completed and accepted including incremental acceptances of portions of the Work by the City.
3. Federal law (49CFR26.29) requires that any delay or postponement of payment over 30 Calendar Days may take place only for good cause and with the City's prior written approval. Any violation of this provision by you or your Subcontractor shall subject you or your Subcontractor to the penalties, sanctions, and other remedies specified in §7108.5 of the Business and Professions Code.
4. These requirements shall not be construed to limit or impair any contractual, administrative, or judicial remedies otherwise available to you or your Subcontractor in the event of a dispute involving late payment or nonpayment by you, deficient subcontract performance, or noncompliance by a Subcontractor.

K. CERTIFICATION.

1. The City accepts certifications of DBE, DVBE, MBE, SMBE, SWBE, or WBE by any of the following certifying agencies:
 - a) Current certification by the State of California Department of Transportation (CALTRANS) as DBE, SMBE, or SWBE.
 - b) Current MBE, WBE, or DVBE certification from the California Public Utilities Commission.
 - c) DVBE certification is received from the State of California's Department of General Services, Office of Small and Minority Business.
 - d) Current certification by the City of Los Angeles as DBE, WBE, or MBE.
 - e) Subcontractors' valid proof of certification status (copies of MBE, WBE, DBE, or DVBE certifications) shall be submitted as required.

L. CONTRACT RECORDS AND REPORTS.

1. You shall maintain records of all subcontracts and invoices from your

Subcontractors and Suppliers for work on this project. Records shall show name, telephone number including area code, and business address of each Subcontractor, Supplier, and joint venture partner, and the total amount actually paid to each firm. Project relevant records, regardless of tier, may be periodically reviewed by the City.

2. You shall retain all records, books, papers, and documents pertinent to the Contract for a period of not less than 5 years after Notice of Completion and allow access to said records by the City's authorized representatives.
3. You shall submit the following reports using the City's web-based contract compliance (Prism® portal):
 - a. **Monthly Payment.** You shall submit Monthly Payment Reporting by the 10th day of the subsequent month. Incomplete and/or delinquent reporting may cause payment delays, non-payment of invoices, or both.
3. You shall submit the following reports using the web-based contract compliance software, LCP Tracker Online Payroll Reporting:
 - a. **Monthly Payment.** You and your Subcontractors and Suppliers shall submit Monthly Payment Reporting by the 5th day of the subsequent month. Incomplete and/or delinquent reporting may cause payment delays, non-payment of invoices, or both.
4. The records maintained under item 1, described above, shall be consolidated into a Final Summary Report, certified as correct by an authorized representative of the Contractor. The Final Summary Report shall include all subcontracting activities and be sent to the EOCP Program Manager prior to Acceptance. Failure to comply may result in assessment of liquidated damages or withholding of retention. The City will review and verify 100% of subcontract participation reported in the Final Summary Report prior to approval and release of final retention to you. In the event your Subcontractors are owed money for completed Work, the City may authorize payment to subcontractor via a joint check from the withheld retention.

ATTACHMENT D
PREVAILING WAGES

PREVAILING WAGES

1. **PREVAILING WAGE RATES:** Pursuant to San Diego Municipal Code section 22.3019, construction, alteration, demolition, repair and maintenance work performed under this Contract is subject to State prevailing wage laws. For construction work performed under this Contract cumulatively exceeding \$25,000 and for alteration, demolition, repair and maintenance work performed under this Contract cumulatively exceeding \$15,000, the Contractor and its subcontractors shall comply with State prevailing wage laws including, but not limited to, the requirements listed below.
 - 1.1. **Compliance with Prevailing Wage Requirements.** Pursuant to sections 1720 through 1861 of the California Labor Code, the Contractor and its subcontractors shall ensure that all workers who perform work under this Contract are paid not less than the prevailing rate of per diem wages as determined by the Director of the California Department of Industrial Relations (DIR). This includes work performed during the design and preconstruction phases of construction including, but not limited to, inspection and land surveying work.
 - 1.1.1. Copies of such prevailing rate of per diem wages are on file at the City and are available for inspection to any interested party on request. Copies of the prevailing rate of per diem wages also may be found at <http://www.dir.ca.gov/OPRL/DPreWageDetermination.htm>. Contractor and its subcontractors shall post a copy of the prevailing rate of per diem wages determination at each job site and shall make them available to any interested party upon request.
 - 1.1.2. The wage rates determined by the DIR refer to expiration dates. If the published wage rate does not refer to a predetermined wage rate to be paid after the expiration date, then the published rate of wage shall be in effect for the life of this Contract. If the published wage rate refers to a predetermined wage rate to become effective upon expiration of the published wage rate and the predetermined wage rate is on file with the DIR, such predetermined wage rate shall become effective on the date following the expiration date and shall apply to this Contract in the same manner as if it had been published in said publication. If the predetermined wage rate refers to one or more additional expiration dates with additional predetermined wage rates, which expiration dates occur during the life of this Contract, each successive predetermined wage rate shall apply to this Contract on the date following the expiration date of the previous wage rate. If the last of such predetermined wage rates expires during the life of this Contract, such wage rate shall apply to the balance of the Contract.
 - 1.2. **Penalties for Violations.** Contractor and its subcontractors shall comply with California Labor Code section 1775 in the event a worker is paid less than the prevailing wage rate for the work or craft in which the worker is employed. This shall be in addition to any other applicable penalties allowed under Labor Code sections 1720 – 1861.
 - 1.3. **Payroll Records.** Contractor and its subcontractors shall comply with California

subcontractor shall not be qualified to quote on, be listed in a quote or proposal, subject to the requirements of section 4104 of the Public Contract Code, or engage in the performance of any contract for public work, unless currently registered and qualified to perform public work pursuant to Labor Code section 1725.5. It is not a violation of this section for an unregistered contractor to submit a quote that is authorized by Section 7029.1 of the Business and Professions code or by Section 10164 or 20103.5 of the Public Contract Code, provided the contractor is registered to perform public work pursuant to Section 1725.5 at the time the contract is awarded.

1.9.1. A Contractor's inadvertent error in listing a subcontractor who is not registered pursuant to Labor Code section 1725.5 in response to a solicitation shall not be grounds for filing a quote protest or grounds for considering the quote non-responsive provided that any of the following apply: (1) the subcontractor is registered prior to quote opening; (2) within twenty-four hours after the quote opening, the subcontractor is registered and has paid the penalty registration fee specified in Labor Code section 1725.5; or (3) the subcontractor is replaced by another registered subcontractor pursuant to Public Contract Code section 4107.

1.9.2. By submitting a quote or proposal to the City, Contractor is certifying that he or she has verified that all subcontractors used on this public work project are registered with the DIR in compliance with Labor Code sections 1771.1 and 1725.5, and Contractor shall provide proof of registration for themselves and all listed subcontractors to the City at the time of quote or proposal due date or upon request.

1.10. Stop Order. For Contractor or its subcontractors engaging in the performance of any public work contract without having been registered in violation of Labor Code sections 1725.5 or 1771.1, the Labor Commissioner shall issue and serve a stop order prohibiting the use of the unregistered contractors or unregistered subcontractor(s) on ALL public works until the unregistered contractor or unregistered subcontractor(s) is registered. Failure to observe a stop order is a misdemeanor.

1.11. List of all Subcontractors. The Contractor shall provide the list of subcontractors (regardless of tier), along with their DIR registration numbers, utilized on this Contract prior to any work being performed; and the Contractor shall provide a complete list of all subcontractors with each invoice. Additionally, Contractor shall provide the City with a complete list of all subcontractors (regardless of tier) utilized on this contract within ten working days of the completion of the contract, along with their DIR registration numbers. The City shall withhold final payment to Construction Management Professional until at least thirty (30) days after this information is provided to the City.

1.12. Exemptions for Small Projects. There are limited exemptions for installation, alteration, demolition, or repair work done on projects of \$25,000 or less. The Contractor shall still comply with Labor Code sections 1720 et. seq. The only recognized exemptions are listed below:

- 1.12.1.** Registration. The Contractor will not be required to register with the DIR for small projects. (Labor Code section 1771.1)
- 1.12.2.** Certified Payroll Records. The records required in Labor Code section 1776 shall be required to be kept and submitted to the City of San Diego, but will not be required to be submitted online with the DIR directly. The Contractor will need to keep those records for at least three years following the completion of the Contract. (Labor Code section 1771.4).
- 1.12.3.** List of all Subcontractors. The Contractor shall not be required to hire only registered subcontractors and is exempt from submitting the list of all subcontractors that is required in section 1.11 above. (Labor code section 1773.3).

ATTACHMENT E
SUPPLEMENTARY SPECIAL PROVISIONS

SUPPLEMENTARY SPECIAL PROVISIONS

The following Supplementary Special Provisions (SSP) modifies the following documents:

1. The **2021 Edition** of the Standard Specifications for Public Works Construction (The "GREENBOOK").
 2. The **2021 Edition** of the City of San Diego Standard Specifications for Public Works Construction (The "WHITEBOOK"), including the following:
 - a) General Provisions (A) for all Construction Contracts.
-

SECTION 5 – LEGAL RELATIONS AND RESPONSIBILITIES

5-4 INSURANCE. To the "GREENBOOK", DELETE in its entirety and SUBSTITUTE with the following:

5-4 INSURANCE.

1. The insurance provisions herein shall not be construed to limit your indemnity obligations contained in the Contract.

5-4.1 Policies and Procedures.

1. You shall procure the insurance described below, at its sole cost and expense, to provide coverage against claims for loss including injuries to persons or damage to property, which may arise out of or in connection with the performance of the Work by you, your agents, representatives, officers, employees or Subcontractors.
2. Insurance coverage for property damage resulting from your operations is on a replacement cost valuation. The market value will not be accepted.
3. You shall maintain this insurance for the duration of this Contract and at all times thereafter when you are correcting, removing, or replacing Work in accordance with this Contract. Your liabilities under the Contract, e.g., your indemnity obligations, is not deemed limited to the insurance coverage required by this Contract.
4. The payment for insurance shall be included in the Contract Price as bid by you. Except as specifically agreed to by the City in writing, you are not entitled to any additional payment. Do not begin any Work under this

Contract until you have provided and the City has approved all required insurance.

5. Policies of insurance shall provide that the City is entitled to 30 Days (10 Days for cancellation due to non-payment of premium) prior written notice of cancellation or non-renewal of the policy. Maintenance of specified insurance coverage is a material element of the Contract. Your failure to maintain or renew coverage or to provide evidence of renewal during the term of the Contract may be treated by the City as a material breach of the Contract.

5-4.2 Types of Insurance.

5-4.2.1 Commercial General Liability Insurance.

1. Commercial General Liability Insurance shall be written on the current version of the ISO Occurrence form CG 00 01 07 98 or an equivalent form providing coverage at least as broad.
2. The policy shall cover liability arising from premises and operations, XCU (explosions, underground, and collapse), independent contractors, products/completed operations, personal injury and advertising injury, bodily injury, property damage, and liability assumed under an insured's contract (including the tort liability of another assumed in a business contract).
3. There shall be no endorsement or modification limiting the scope of coverage for either "insured vs. insured" claims or contractual liability. You shall maintain the same or equivalent insurance for at least 10 years following completion of the Work.
4. All costs of defense shall be outside the policy limits. Policy coverage shall be in liability limits of not less than the following:

<u>General Annual Aggregate Limit</u>	<u>Limits of Liability</u>
Other than Products/Completed Operations	\$2,000,000
Products/Completed Operations Aggregate Limit	\$2,000,000
Personal Injury Limit	\$1,000,000
Each Occurrence	\$1,000,000

5-4.2.2 Commercial Automobile Liability Insurance.

1. You shall provide a policy or policies of Commercial Automobile Liability Insurance written on the current version of the ISO form CA 00 01 12 90 or later version or equivalent form providing coverage at least as broad in the amount of \$1,000,000 combined single limit per accident, covering bodily injury and property damage for owned, non-owned, and hired automobiles ("Any Auto").
2. All costs of defense shall be outside the limits of the policy.

5-4.3 Rating Requirements. Except for the State Compensation Insurance Fund, all insurance required by this Contract as described herein shall be carried only by responsible insurance companies with a rating of, or equivalent to, at least “A-, VI” by A.M. Best Company, that are authorized by the California Insurance Commissioner to do business in the State, and that have been approved by the City.

5-4.3.1 Non-Admitted Carriers. The City will accept insurance provided by non-admitted, “surplus lines” carriers only if the carrier is authorized to do business in the State and is included on the List of Approved Surplus Lines Insurers (LASLI list).

All policies of insurance carried by non-admitted carriers shall be subject to all of the requirements for policies of insurance provided by admitted carriers described herein.

5-4.4 Evidence of Insurance. Furnish to the City documents e.g., certificates of insurance and endorsements evidencing the insurance required herein, and furnish renewal documentation prior to expiration of this insurance. Each required document shall be signed by the insurer or a person authorized by the insurer to bind coverage on its behalf. We reserve the right to require complete, certified copies of all insurance policies required herein.

5-4.5 Policy Endorsements.

5-4.5.1 Commercial General Liability Insurance.

5-4.5.1.1 Additional Insured.

1. You shall provide at your expense policy endorsement written on the current version of the ISO Occurrence form CG 20 10 11 85 or an equivalent form providing coverage at least as broad.
2. To the fullest extent allowed by law e.g., California Insurance Code §11580.04, the policy shall be endorsed to include the City and its respective elected officials, officers, employees, agents, and representatives as additional insured.
3. The additional insured coverage for projects for which the Engineer’s Estimate is \$1,000,000 or more shall include liability arising out of:
 - a) Ongoing operations performed by you or on your behalf,
 - b) your products,
 - c) your Work, e.g., your completed operations performed by you or on your behalf, or
 - d) premises owned, leased, controlled, or used by you.
4. The additional insured coverage for projects for which the Engineer’s Estimate is less than \$1,000,000 shall include liability arising out of:
 - a) Ongoing operations performed by you or on your behalf,

- b) your products, or
- c) premises owned, leased, controlled, or used by you.

5-4.5.1.2 Primary and Non-Contributory Coverage. The policy shall be endorsed to provide that the coverage with respect to operations, including the completed operations, if appropriate, of the Named Insured is primary to any insurance or self-insurance of the City and its elected officials, officers, employees, agents and representatives. Further, it shall provide that any insurance maintained by the City and its elected officials, officers, employees, agents and representatives shall be in excess of your insurance and shall not contribute to it.

5-4.5.1.3 Project General Aggregate Limit. The policy or policies shall be endorsed to provide a Designated Construction Project General Aggregate Limit that will apply only to the Work. Only claims payments which arise from the Work shall reduce the Designated Construction Project General Aggregate Limit. The Designated Construction Project General Aggregate Limit shall be in addition to the aggregate limit provided for the products-completed operations hazard.

5-4.5.2 Commercial Automobile Liability Insurance.

5-4.5.2.1 Additional Insured. Unless the policy or policies of Commercial Auto Liability Insurance are written on an ISO form CA 00 01 12 90 or a later version of this form or equivalent form providing coverage at least as broad, the policy shall be endorsed to include the City and its respective elected officials, officers, employees, agents, and representatives as additional insured, with respect to liability arising out of automobiles owned, leased, hired or borrowed by you or on your behalf. This endorsement is limited to the obligations permitted by California Insurance Code §11580.04.

5-4.6 Deductibles and Self-Insured Retentions. You shall pay for all deductibles and self-insured retentions. You shall disclose deductibles and self-insured retentions to the City at the time the evidence of insurance is provided.

5-4.7 Reservation of Rights. The City reserves the right, from time to time, to review your insurance coverage, limits, deductibles and self-insured retentions to determine if they are acceptable to the City. The City will reimburse you, without overhead, profit, or any other markup, for the cost of additional premium for any coverage requested by the Engineer but not required by this Contract.

5-4.8 Notice of Changes to Insurance. You shall notify the City 30 Days prior to any material change to the policies of insurance provided under this Contract.

5-4.9 Excess Insurance. Policies providing excess coverage shall follow the form of the primary policy or policies e.g., all endorsements.

5-4.11 Workers' Compensation Insurance and Employers Liability Insurance.

1. In accordance with the provisions of §3700 of the California Labor Code, you shall provide at your expense Workers' Compensation Insurance and

Employers Liability Insurance to protect you against all claims under applicable state workers compensation laws. The City, its elected officials, and employees will not be responsible for any claims in law or equity occasioned by your failure to comply with the requirements of this section.

- 2. Limits for this insurance shall be not less than the following:

<u>Workers' Compensation</u>	<u>Statutory Employers Liability</u>
Bodily Injury by Accident	\$1,000,000 each accident
Bodily Injury by Disease	\$1,000,000 each employee
Bodily Injury by Disease	\$1,000,000 policy limit

- 3. By signing and returning the Contract you certify that you are aware of the provisions of §3700 of the Labor Code which requires every employer to be insured against liability for worker's compensation or to undertake self-insurance in accordance with the provisions of that code and you shall comply with such provisions before commencing the Work as required by §1861 of the California Labor Code.

5-4.11.1. Waiver of Subrogation. The policy or policies shall be endorsed to provide that the insurer will waive all rights of subrogation against the City and its respective elected officials, officers, employees, agents, and representatives for losses paid under the terms of the policy or policies and which arise from Work performed by the Named Insured for the City.

ATTACHMENT F

**IN-USE OFF-ROAD DIESEL FUELED FLEET REGULATION (OFF-ROAD REGULATION)
COMPLIANCE (CARB)**

ATTACHMENT F

IN-USE OFF-ROAD DIESEL FUELED FLEET REGULATION (OFF-ROAD REGULATION) COMPLIANCE

The California Air Resources Board (CARB) approved amendments to the Off-Road Regulations which can be found at 13 California Code of Regulations (CCR) sections 2449, 2449.1, and 2449.2. These amendments apply to any person, business, or government agency who owns or operates within California any vehicles with a diesel-fueled or alternative diesel fueled off-road compression-ignition engine with maximum power (max hp) of 25 horsepower (hp) or greater provided that the vehicle cannot be registered and driven safely on-road or was not designed to be driven on-road, even if it has been modified so that it can be driven safely on-road. See 13 CCR section 2449 (b) for the full list of vehicles covered by these Off-Road Regulations.

Beginning January 1, 2024, Contractor shall be subject to the requirements below. No Contractor or public works awarding body, as applicable, shall enter into a contract with a fleet for which it does not have a valid Certificate of Reported Compliance for the fleet and its listed subcontractors, if applicable, prior to entering into a new or renewed contract with that fleet. Contractor shall comply with the following requirements:

(1) For a project involving the use of vehicles subject to the Off-Road Regulation, Contractor must obtain copies of the valid Certificates of Reported Compliance, as described in 13 CCR section 2449(n), for the fleet selected for this Contract and their listed subcontractors, if applicable, prior to entering into a new or renewed contract with that fleet and provide copies of such Certificates of Reported Compliance to the City within 10 days of issuance of the Notice of Intent to Award letter. Contractor shall enter into a contract with a fleet for which it does not have a valid Certificates of Reported Compliance for the fleet and its listed subcontractors. City shall not enter into a contract with Contractor until all current Certificates of Reported Compliance for the fleet to be used on this Project are provided by Contractor.

(2) The Certificates of Reported Compliance received by Contractor for this Project must be retained by Contractor for three years after the Project's completion. Upon request by CARB, these records must be provided to CARB within five business days of the request. Additionally, upon request by City, these records must be produced to City within five business days of the request.

(3) For emergency contracts that meet the definition of "emergency operations" as defined in 13 CCR section 2449(c)(18), they are exempt from the requirements in 13 CCR section 2449(i)(1)-(3) and sections (1) and (2) above, but must still retain records verifying vehicles subject to the regulation that are operating on the "emergency operations" project are actually being operated on the project for "emergency operations" only. These records, as described in more detail below in section (B) must be retained by Contractor for three years after completion of the Project and upon request from either CARB or the City, Contractor shall provide those records to the requesting party within five business

days. All other emergency contracts that do not meet the definition of “emergency operations” must comply with the requirements above and 13 CCR section 2449(i)(1) – (3).

A. “Emergency Operations” is defined as:

1. Any activity for a project conducted during emergency, life threatening situations, where a sudden, unexpected occurrence that poses a clear and imminent danger, requiring immediate action to prevent or mitigate the loss or impairment of life, health, property, or an essential public service; or in conjunction with any officially declared disaster or state of emergency, as declared by an authorized health officer, agricultural commissioner, fire protection officer, or other authorized health officer;
2. Any activity for a project conducted by essential service utilities to provide electricity, natural gas, telephone, water, or sewer during periods of service outages and emergency; or
3. Operations including repairing or preventing damage to roads, buildings, terrain, and infrastructure as a result of an earthquake, flood, storm, fire, other infrequent act of nature, or terrorism. Routine maintenance or construction to prevent public health risks does not constitute emergency operations under the Off-Road Regulations.

B. The records retained by Contractor for “emergency operations” projects must include:

1. A description of the emergency;
2. The address or a description of the specific location of the emergency;
3. The dates on which the emergency operations were performed; and
4. An attestation by the fleet that the vehicles are operated on the Project for “emergency operations” only.

Beginning January 1, 2024, Contractor is also subject to the requirements described in 13 CCR section 2449(j).

(1) Between March 1 and June 1 of each year, Contractor must collect new valid Certificates of Reported Compliance for the current compliance year, as defined in 13 CCR section 2449(n), from all fleets that have an ongoing contract with Contractor as of March 1 of that year. Contractors shall not write contracts to evade this requirement.

(2) Contractor shall only allow fleets with valid Certificates of Reported Compliance on the Contractor's job sites.

(3) If Contractor discovers that any fleet intending to operate vehicles subject to this regulation for Contractor does not have a valid Certificate of Reported Compliance, as defined in 13 CCR section 2449(n), or if Contractor observes any noncompliant vehicles

subject to the regulation on Contractor's job site, then Contractor must report the that to CARB at <https://calepacomplaints.secure.force.com/complaints/Complaint>, or email dieselcomplaints@arb.ca.gov, for each fleet without a valid Certificate of Reported Compliance or each noncompliant vehicle, as applicable, within five business days of such discovery. See 13 CCR 2449(n) for the information required to be disclosed to CARB when reporting non-compliance.

(4) Upon request by CARB, Contractor must immediately disclose to CARB the name and contact information of each responsible party for all vehicles subject to this regulation operating at the job site or for Contractor.

(5) Contractor shall prominently display signage for any project where vehicles subject to this Off-Road Regulation will operate for 8 calendar days or more. The signage must be posted by the eighth calendar day from which the first vehicle operates. The signage will be in lettering larger than size 14-point type and displayed in a conspicuous place where notices to employees are customarily posted at the job site or where there is employee foot traffic. If one of the above locations is also viewable by the public, it should be posted at that location. An exemption to this posting requirement is permitted if the operational time of a project is 7 calendar days or less. The signage must include the following language, verbatim:

(A) "Who does the In-Use Off-Road Regulation Apply to?

The In-Use Off-Road Diesel-Fueled Fleets Regulation (Off-Road Regulation) applies to all self-propelled off-road diesel vehicles 25 horsepower or greater and most two-engine vehicles (except on-road two-engine sweepers) owned or operated in California. This includes vehicles that are rented or leased (rental or leased fleets)."

(B) "In-Use Off-Road Regulation Requirements

Idling Limit: Vehicles cannot idle longer than five minutes. There are exceptions for vehicles that need to idle to perform work.

Labeling: Vehicles must be labeled with a CARB assigned equipment identification number (EIN). The EIN shall be white on a red background, unless the vehicle is part of a captive attainment area fleet, in which case the EIN shall be white on a green background.

The EIN shall be located in clear view on both sides of the outside of the vehicle."

ATTACHMENT G
CONTRACT AGREEMENT

CONTRACT AGREEMENT

CONSTRUCTION CONTRACT

This contract is made and entered into between THE CITY OF SAN DIEGO, a municipal corporation, herein called "City", and **3-D Enterprises, Inc.**, herein called "Contractor" for construction of **Walkway at Marie Widman Memorial Park**; Contract No. **M-25-0090**; in the amount of **Fifty Two Thousand Six Hundred Dollars and Zero Cents (\$52,600.00)**, which is comprised of the quote.

IN CONSIDERATION of the payments to be made hereunder and the mutual undertakings of the parties hereto, City and Contractor agree as follows:

1. The following are incorporated into this contract as though fully set forth herein:
 - (a) Payment Bond.
 - (b) Proposal included in the Quote documents by the Contractor.
 - (c) Reference Standards listed in the Instruction to Contractors and the Supplementary Special Provisions (SSP).
 - (d) That certain documents entitled [Walkway at Marie Widman Memorial Park], on file in the office of the Purchasing & Contracting Department.
2. The Contractor shall perform and be bound by all the terms and conditions of this contract and in strict conformity therewith shall perform and complete in a good and workmanlike manner [Walkway at Marie Widman Memorial Park, Minor Contract Number: M-25-0090], San Diego, California.
3. For such performances, the City shall pay to Contractor the amounts set forth at the times and in the manner and with such additions or deductions as are provided for in this contract, and the Contractor shall accept such payment in full satisfaction of all claims incident to such performances.
4. No claim or suit whatsoever shall be made or brought by Contractor against any officer, agent, or employee of the City for or on account of anything done or omitted to be done in connection with this contract, nor shall any such officer, agent, or employee be liable hereunder.
5. This contract is effective as of the date that the Mayor or designee and City Attorney signs the agreement.

CONTRACT AGREEMENT (continued)

IN WITNESS WHEREOF, this Agreement is signed by the City of San Diego, acting by and through its Mayor or designee, pursuant to Municipal Code §22.3102 authorizing such execution.

THE CITY OF SAN DIEGO

APPROVED AS TO FORM

By 

Heather Ferbert, City Attorney
By 

Print Name: Stephen Samara
Principal Contract Specialist
Purchasing & Contracting Department

Print Name: Alma Robbins
Deputy City Attorney

Date: 2/27/2025

Date: 3/10/25

CONTRACTOR

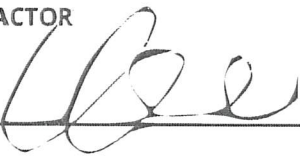
By 

Print Name: Shahrokh Elihu

Title: Vice President

Date: 02/24/25

City of San Diego License No.: B1994008349

State Contractor's License No.: 621125

DEPARTMENT OF INDUSTRIAL RELATIONS (DIR) REGISTRATION NUMBER: 1000003754

CERTIFICATIONS AND FORMS

The Contractor, by submitting its electronic quote, agrees to and certifies under penalty of perjury under the laws of the State of California, that the certifications, forms and affidavits submitted as part of this quote are true and correct.

Contractor's General Information

To the City of San Diego:

Pursuant to "Notice Inviting Quotes", specifications, and requirements on file with the City Clerk, and subject to all provisions of the Charter and Ordinances of the City of San Diego and applicable laws and regulations of the United States and the State of California, the undersigned hereby proposes to furnish to the City of San Diego, complete at the prices stated herein, the items or services hereinafter mentioned. The undersigned further warrants that this quote is not made in the interest of, or on behalf of, any undisclosed person, partnership, company, association, organization, or corporation; that the quote is genuine and not collusive or sham; that the Contractor has not directly or indirectly induced or solicited any other Contractor to put in a false or sham quote, and has not directly or indirectly colluded, conspired, connived, or agreed with any Contractor or anyone else to put in a sham quote, or that anyone shall refrain from bidding; that the Contractor has not in any manner, directly or indirectly, sought by agreement, communication, or conference with anyone to fix the quote price of the Contractor or any other Contractor, or to fix any overhead, profit, or cost element of the quote price, or of that of any other Contractor, or to secure any advantage against the public body awarding the contract of anyone interested in the proposed contract; that all statements contained in the quote are true; and, further, that the Contractor has not, directly or indirectly, submitted his or her quote price or any breakdown thereof, or the contents thereof, or divulged information or data relative thereto, or paid, and will not pay, any fee to any corporation, partnership, company, association, organization, quote depository, or to any member or agent thereof to effectuate a collusive or sham quote.

The undersigned Contractor(s) further warrants that Contractor(s) has thoroughly examined and understands the entire Contract Documents (plans and specifications) and the Bidding Documents therefore, and that by submitting said Bidding Documents as its quote proposal, Contractor(s) acknowledges and is bound by the entire Contract Documents, including any addenda issued thereto, as such Contract Documents incorporated by reference in the Bidding Documents.

**NON-COLLUSION AFFIDAVIT TO BE EXECUTED BY CONTRACTOR AND SUBMITTED WITH
QUOTE UNDER 23 UNITED STATES CODE 112 AND PUBLIC CONTRACT CODE 7106**

State of California

County of San Diego

The Contractor, being first duly sworn, deposes and says that he or she is authorized by the party making the foregoing quote that the quote is not made in the interest of, or on behalf of, any undisclosed person, partnership, company, association, organization, or corporation; that the quote is genuine and not collusive or sham; that the Contractor has not directly or indirectly induced or solicited any other Contractor to put in a false or sham quote, and has not directly or indirectly colluded, conspired, connived, or agreed with any Contractor or anyone else to put in a sham quote, or that anyone shall refrain from bidding; that the Contractor has not in any manner, directly or indirectly, sought by agreement, communication, or conference with anyone to fix the quote price of the Contractor or any other Contractor, or to fix any overhead, profit, or cost element of the quote price, or of that of any other Contractor, or to secure any advantage against the public body awarding the contract of anyone interested in the proposed contract; that all statements contained in the quote are true; and further, that the Contractor has not, directly or indirectly, submitted his or her quote price or any breakdown thereof, or the contents thereof, or divulged information or data relative thereto, or paid, and will not pay, any fee to any corporation, partnership, company association, organization, quote depository, or to any member or agent thereof to effectuate a collusive or sham quote.

CONTRACTOR CERTIFICATION

DRUG-FREE WORKPLACE

I hereby certify that I am familiar with the requirements of San Diego City Council Policy No. 100-17 regarding Drug-Free Workplace as outlined in the WHITEBOOK, Section 5-1.3, "Drug-Free Workplace", of the project specifications, and that;

This company has in place a drug-free workplace program that complies with said policy. I further certify that each subcontract agreement for this project contains language which indicates the subcontractor's agreement to abide by the provisions of subdivisions a) through c) of the policy as outlined.

CONTRACTOR CERTIFICATION

AMERICAN WITH DISABILITIES ACT (ADA) COMPLIANCE CERTIFICATION

I hereby certify that I am familiar with the requirements of San Diego City Council Policy No. 100-4 regarding the American With Disabilities Act (ADA) outlined in the WHITEBOOK, Section 5-1.2, "California Building Code, California Code of Regulations Title 24 and Americans with Disabilities Act", of the project specifications, and that:

This company has in place workplace program that complies with said policy. I further certify that each subcontract agreement for this project contains language which indicates the subcontractor's agreement to abide by the provisions of the policy as outlined.

CONTRACTOR CERTIFICATION

CONTRACTOR STANDARDS – PLEDGE OF COMPLIANCE

I declare under penalty of perjury that I am authorized to make this certification on behalf of the company submitting this quote, that as Contractor, I am familiar with the requirements of City of San Diego Municipal Code § 22.3004 regarding Contractor Standards as outlined in the WHITEBOOK, Section 5-1.4, ("Contractor Standards and Pledge of Compliance"), of the project specifications, and that Contractor has complied with those requirements.

I further certify that each of the Contractor's subcontractors has completed a Pledge of Compliance attesting under penalty of perjury of having complied with City of San Diego Municipal Code § 22.3004.

CONTRACTOR CERTIFICATION

Equal Benefits Ordinance Certification

I declare under penalty of perjury that I am familiar with the requirements of and in compliance with the City of San Diego Municipal Code § 22.4300 regarding Equal Benefits Ordinance.

CONTRACTOR CERTIFICATION

Equal Pay Ordinance Certification

Contractor shall comply with the Equal Pay Ordinance (EPO) codified in the San Diego Municipal Code (SDMC) at section 22.4801 through 22.4809, unless compliance is not required based on an exception listed in SDMC section 22.4804.

Contractor shall require all of its subcontractors to certify compliance with the EPO in their written subcontracts.

Contractor must post a notice informing its employees of their rights under the EPO in the workplace or job site.

By signing this Contract with the City of San Diego, Contractor acknowledges the EPO requirements and pledges ongoing compliance with the requirements of SDMC Division 48, section 22.4801 et seq., throughout the duration of this Contract.

CONTRACTOR CERTIFICATION

In-Use Off-Road Diesel Fueled Fleet Regulation (Off-Road Regulation) Compliance

I hereby certify that Contractor is familiar with the requirements 13 CCR 2449, 2449.1, and 2449.2, as well as Attachment F, In-Use Off-Road Diesel Fueled Fleet Regulation (Off-Road Regulation) Compliance (CARB), and that Contractor shall comply with these requirements.

I further certify that each of the Contractor's listed subcontractors is familiar with these requirements and shall also comply.

CONTRACTOR CERTIFICATION

PRODUCT ENDORSEMENT

I declare under penalty of perjury that I acknowledge and agree to comply with the provisions of City of San Diego Administrative Regulation 95.65, concerning product endorsement. Any advertisement identifying or referring to the City as the user of a product or service requires the prior written approval of the City.

ELECTRONICALLY SUBMITTED FORMS

THE FOLLOWING FORMS MUST BE SUBMITTED IN PDF FORMAT WITHIN 3 WORKING DAYS OF THE NOTICE OF INTENT TO AWARD (NOI)

The following forms are to be completed by the Contractor and submitted electronically.

- A. CONTRACTOR'S CERTIFICATION OF PENDING ACTIONS**
- B. MANDATORY DISCLOSURE OF BUSINESS INTERESTS FORM**
- C. LIST OF SUBCONTRACTORS (INCLUDING TIER)**
- D. DEBARMENT AND SUSPENSION CERTIFICATION FOR PRIME CONTRACTORS**
- E. DEBARMENT AND SUSPENSION CERTIFICATION FOR SUBCONTRACTORS, SUPPLIERS, AND MANUFACTURERS**

Quotes will not be accepted until ALL the above-named forms are submitted.

CONTRACTOR'S CERTIFICATION OF PENDING ACTIONS

As part of its quote, the Contractor shall provide to the City a list of all instances within the past 10 years where a complaint was filed or pending against the Contractor in a legal or administrative proceeding alleging that Contractor discriminated against its employees, subcontractors, vendors or suppliers, and a description of the status or resolution of that complaint, including any remedial action taken.

CHECK ONE BOX ONLY.

- The undersigned certifies that within the past 10 years the Contractor has NOT been the subject of a complaint or pending action in a legal administrative proceeding alleging that Contractor discriminated against its employees, subcontractors, vendors or suppliers.

- The undersigned certifies that within the past 10 years the Contractor has been the subject of a complaint or pending action in a legal administrative proceeding alleging that Contractor discriminated against its employees, subcontractors, vendors or suppliers. A description of the status or resolution of that complaint, including any remedial action taken and the applicable dates is as follows:

DATE OF CLAIM	LOCATION	DESCRIPTION OF CLAIM	LITIGATION (Y/N)	STATUS	RESOLUTION/REMEDIAL ACTION TAKEN

Contractor Name: 3-D Enterprises, Incorporated

Certified By Shahrokh Elihu Title Vice President

 Name _____ Date 02/26/25
 Signature _____

USE ADDITIONAL FORMS AS NECESSARY

Mandatory Disclosure of Business Interests Form

CONTRACTOR/PROPOSER INFORMATION

Legal Name		DBA	
3-D Enterprises, Incorporated			
Street Address	City	State	Zip
3665 Ruffin Road, Ste. 103, San Diego		CA	92123
Contact Person, Title		Phone	Fax
S. Elihu, Vice President		858-530-2202	844-318-2832

Provide the name, identity, and precise nature of the interest* of all persons who are directly or indirectly involved** in this proposed transaction (SDMC § 21.0103).

* The precise nature of the interest includes:

- the percentage ownership interest in a party to the transaction,
- the percentage ownership interest in any firm, corporation, or partnership that will receive funds from the transaction,
- the value of any financial interest in the transaction,
- any contingent interest in the transaction and the value of such interest should the contingency be satisfied, and
- any philanthropic, scientific, artistic, or property interest in the transaction.

** Directly or indirectly involved means pursuing the transaction by:

- communicating or negotiating with City officers or employees,
- submitting or preparing applications, bids, proposals or other documents for purposes of contracting with the City, or
- directing or supervising the actions of persons engaged in the above activity.

Name	Title/Position
Doris Elghanayan	President
City and State of Residence	Employer (if different than Contractor/Proposer)
Del Mar, CA	
Interest in the transaction	
70% ownership	

Name	Title/Position
Shahrokh 'Shawn' Elihu	Vice President
City and State of Residence	Employer (if different than Contractor/Proposer)
Del Mar, CA	
Interest in the transaction	
30% ownership	

* Use Additional Pages if Necessary *

Under penalty of perjury under the laws of the State of California, I certify that I am responsible for the completeness and accuracy of the responses contained herein, and that all information provided is true, full and complete to the best of my knowledge and belief. I agree to provide written notice to the Mayor or Designee within five (5) business days if, at any time, I learn that any portion of this Mandatory Disclosure of Business Interests Form requires an updated response. Failure to timely provide the Mayor or Designee with written notice is grounds for Contract termination.

S. Elihu, Vice President

02/24/25

Print Name, Title

Signature

Date

Failure to sign and submit this form with the bid/proposal shall make the bid/proposal non-responsive. In the case of an informal solicitation, the contract will not be awarded unless a signed and completed Mandatory Disclosure of Business Interests Form is submitted.

Mandatory Disclosure of Business Interests Form

CONTRACTOR/PROPOSER INFORMATION

Legal Name		DBA	
3-D Enterprises, Incorporated			
Street Address	City	State	Zip
3665 Ruffin Road, Ste. 103, San Diego	San Diego	CA	92123
Contact Person, Title		Phone	Fax
S. Elihu, Vice President		858-530-2202	844-318-2832

Provide the name, identity, and precise nature of the interest* of all persons who are directly or indirectly involved** in this proposed transaction (SDMC § 21.0103).

* The precise nature of the interest includes:

- the percentage ownership interest in a party to the transaction,
- the percentage ownership interest in any firm, corporation, or partnership that will receive funds from the transaction,
- the value of any financial interest in the transaction,
- any contingent interest in the transaction and the value of such interest should the contingency be satisfied, and
- any philanthropic, scientific, artistic, or property interest in the transaction.

** Directly or indirectly involved means pursuing the transaction by:

- communicating or negotiating with City officers or employees,
- submitting or preparing applications, bids, proposals or other documents for purposes of contracting with the City, or
- directing or supervising the actions of persons engaged in the above activity.

Name	Title/Position
Danny Silvestre	Project Engineer
City and State of Residence	Employer (if different than Contractor/Proposer)
San Diego, CA	
Interest in the transaction	
Communicating with City officers or employees	

Name	Title/Position
Cecilia Galvan	Office Manager
City and State of Residence	Employer (if different than Contractor/Proposer)
Chula Vista, CA	
Interest in the transaction	
submitting/preparing bids or other documents for purposes of contracting with City, communicating with City officers/employees	

* Use Additional Pages if Necessary *

Under penalty of perjury under the laws of the State of California, I certify that I am responsible for the completeness and accuracy of the responses contained herein, and that all information provided is true, full and complete to the best of my knowledge and belief. I agree to provide written notice to the Mayor or Designee within five (5) business days if, at any time, I learn that any portion of this Mandatory Disclosure of Business Interests Form requires an updated response. Failure to timely provide the Mayor or Designee with written notice is grounds for Contract termination.

S. Elihu, Vice President

Print Name, Title

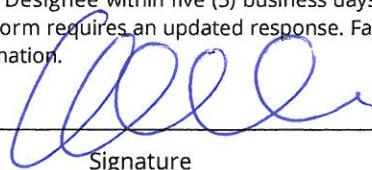

Signature

02/24/25

Date

Failure to sign and submit this form with the bid/proposal shall make the bid/proposal non-responsive. In the case of an informal solicitation, the contract will not be awarded unless a signed and completed Mandatory Disclosure of Business Interests Form is submitted.

LIST OF SUBCONTRACTORS (INCLUDING TIER)

In accordance with the requirements of the "Subletting and Subcontracting Fair Practices Act", Section 4100, of the California Public Contract Code (PCC), the Contractor is to list below the name, address and license number of each Subcontractor who will perform work, labor, render services or specially fabricate and install a portion [type] of the work or improvement, in an amount of or in excess of 0.5% of the Contractor's total Bid. The Contractor is to list only one Subcontractor for each portion of the Work. The Contractor's attention is directed to the Special Provisions - General; Paragraph 2-3 Subcontracts, which stipulates the percentage of the Work to be performed with the Contractor's own forces. In addition, the Contractor is to list below the name address, license number, DIR registration of any known tiered subcontractors who will perform work, labor, render services or specially fabricate and install a portion [type] of the work or improvement pursuant to the contract. It is the responsibility of the Contractor to notify the City of any additional subcontractors, including tiered, that are utilized on the project as soon as it is known.

If no subcontractors are being utilized for this contract, please fill in form using "N/A" (not applicable) and submit accordingly. Use of "N/A" for work that exceeds 0.5%, or failure to list a subcontractor for work that exceeds 0.5% of the Contractor's total Bid indicates the Contractor will self-perform the work.

NAME, ADDRESS AND TELEPHONE NUMBER OF SUBCONTRACTOR	SUB TYPE (C or D*)	DIR REGISTRATION NUMBER	SUBCONTRACTOR LICENSE NUMBER	TYPE OF WORK	DOLLAR VALUE OF SUBCONTRACT	IDENTIFICATION OF SUB TIER LEVEL (1 ST , 2 ND , 3 RD , ETC.)**	NAME OF CONTRACTOR REPORTING TO
Name: _____ Address: _____ City: _____ State: _____ Zip: _____ Phone: _____ Email: _____	None						
Name: _____ Address: _____ City: _____ State: _____ Zip: _____ Phone: _____ Email: _____							
Name: _____ Address: _____ City: _____ State: _____ Zip: _____ Phone: _____ Email: _____							

*C - Constructor (builder)

*D - Designer (Preparing or modifying designs for construction projects)

** 1st tier means subcontractor is reporting directly to the prime contractor. 2nd tier means the subcontractor is reporting to the 1st tier subcontractor, and so on.

**** USE ADDITIONAL FORMS AS NECESSARY ****

DEBARMENT AND SUSPENSION CERTIFICATION

EFFECT OF DEBARMENT OR SUSPENSION
To promote integrity in the City's contracting processes and to protect the public interest, the City shall only enter into contracts with responsible Contractors and contractors. In accordance with San Diego Municipal Code §22.0814 (a): <i>Contractors and contractors who have been debarred or suspended</i> are excluded from submitting bids, submitting responses to requests for proposal or qualifications, receiving <i>contract</i> awards, executing <i>contracts</i> , participating as a <i>subcontractor</i> , employee, agent or representative of another <i>person</i> contracting with the City.

As part of its bid or proposal (Non-Price Proposal in the case of Design-Build contracts), the Contractor shall provide to the City a list of Names of the Principal Individual owner(s).

The names of all persons interested in the foregoing proposal as Principals are as follows:

NAME	TITLE
Doris Elghanayan	President
Shahrokh Elihu	Vice President

IMPORTANT NOTICE: If Contractor or other interested person is a corporation, state secretary, treasurer, and manager thereof; if a co-partnership, state true name of firm, also names of all individual co-partners composing firm; if Contractor or other interested person is an individual, state first and last names in full.

The Contractor, under penalty of perjury, certifies that, except as noted below, he/she or any person associated therewith in the capacity of owner, partner, director, officer, manager:

- Is not currently under suspension, debarment, voluntary exclusion, or determination of ineligibility by any Federal, State or local agency;
- has not been suspended, debarred, voluntarily excluded or determined ineligible by any Federal, State or local agency within the past 3 years;
- does not have a proposed debarment pending; and
- has not been indicted, convicted, or had a civil judgment rendered against it by a court of competent jurisdiction in any matter involving fraud or official misconduct within the past 3 years.

If there are any exceptions to this certification, insert the exceptions in the following space.

Exceptions will be considered in determining Contractor responsibility. For any exception noted above, indicate below to whom it applies, initiating agency, and dates of action.

Contractor Name: 3-D Enterprises, Incorporated

Certified By Shahrokh Elihu Title Vice President

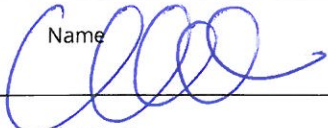
 Name _____
 Signature _____

Date 02/24/25

NOTE: Providing false information may result in criminal prosecution or administrative sanctions.

**DEBARMENT AND SUSPENSION CERTIFICATION
 SUBCONTRACTORS, SUPPLIERS AND MANUFACTURERS
 TO BE COMPLETED BY CONTRACTOR
 IF NONE PLACED N/A ON FORM**

Names of the Principal individual owner(s)

As part of its bid or proposal (Non-Price Proposal in the case of Design-Build contracts), the Contractor shall provide to the City a list of Names of the Principal Individual owner(s) for their subcontractor/supplier/manufacturers.

Please indicate if principal owner is serving in the capacity of **subcontractor, supplier, and/or manufacturer:**

SUBCONTRACTOR SUPPLIER MANUFACTURER

NAME	TITLE
NONE	

SUBCONTRACTOR SUPPLIER MANUFACTURER

NAME	TITLE

SUBCONTRACTOR SUPPLIER MANUFACTURER

NAME	TITLE

SUBCONTRACTOR SUPPLIER MANUFACTURER

NAME	TITLE

Contractor Name: 3-D Enterprises, Incorporated

Certified By Shahrokh Elihu Title Vice President

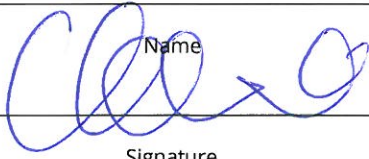
 Name
 Signature

Date 02/24/25

USE ADDITIONAL FORMS AS NECESSARY



Proposal

November 14, 2024

To: City of San Diego
Parks & Recreation Department

Attn: Carlos Rios

RE: Marie Widman Neighborhood Park
449 Ritchey St.
San Diego, CA 92114

Scope of work shall be based on plans sheets 1 thru 4 dated 09/25/24, approximate 200 linear feet of 5' wide sidewalk including excavation & grading for a lump sum price of \$52,600.00 (Fifty-Two Thousand and Six Hundred Dollars with Zero cents).

All work shall be performed per City of San Diego Standards.

Exclusions: Engineering, permit fees.

Please call with any questions.

Sincerely,

Shawn Elihu
3-D Enterprises, Inc.