

**Table 3-3
Estimated Electricity Consumption for North City Project**

Project Component	Estimated Energy Use (kWh/year)
<i>San Vicente Reservoir Alternative</i>	
Morena Pump Station	25,458,000
NCWRP Expansion	32,498,000
NCPWF Influent Pump Station	13,065,000
NCPWF	30,598,000
North City Pump Station and MTBS	40,371,000
North City Renewable Energy Facility (building usage)	2,628,000
MBC Upgrades	15,884,000
Reduction in Collection System and Wastewater Treatment	(15,598,000)
Total San Vicente Reservoir Alternative	144,904,000

Note: kWh/year = kilowatt hours per year

A new North City Renewable Energy Facility is proposed to be located at the NCWRP. Landfill gas from the City’s Miramar Landfill gas collection system will be supplied to the facility via a new 12-inch diameter LFG Pipeline. The new facility will produce a total of 15.4 MW of new generation capacity and will incorporate 5 MW of existing power generation capacity already at NCWRP. The power supplied by the North City Renewable Energy Facility will be used for additional energy needs at the expanded NCWRP as well as for the NCPWF, the NCPWF Influent Pump Station, and the North City Pump Station. Backup power would be provided by SDG&E only to maintain minimal critical operations if the main power supply failed.

Power for the Morena Pump Station and MTBS would be supplied by SDG&E. Backup generators are not anticipated to be required.

3.6 TREATMENT PROCESS AND MAINTENANCE SUMMARY

The North City Project will be planned and coordinated with existing operations, in full compliance with applicable federal, state, and local regulations.

Operations at existing treatment facilities that will be improved or expanded will be integrated into existing operations processes and would continue to follow current protocol.

3.6.1 MORENA PUMP STATION

Wastewater will be conveyed to the Morena Pump Station from four existing sanitary sewer trunk sewers. These sewers collect flows from the City's eastern service area and the areas along the I-5 corridor and all areas south of the City's existing Pump Station 64 located in the Sorrento Valley area. Wastewater conveyed to the Morena Pump Station will be screened by continuous mechanical screens to remove trash, debris, and large solids prior to pumping it to the NCWRP. The pump station will consist of five sets of two stage pumps operating in parallel. Each set would consist of two sewage non-clog pumps operating in series to manage the high head needed to deliver wastewater flows to the NCWRP.

Odor Control

The Morena Pump Station will also include new facilities to manage and address odor control issues from the pump station and the new wastewater force main. Foul air from the pump station wet well and screening facility will be delivered to two large granular activated carbon (GAC) odor control scrubbers. Foul air would be treated by these scrubbers and released to the atmosphere after it has reached acceptable air treatment levels. For the wastewater force main odor control, ferric chloride and/or high purity oxygen would be injected into the force main to control the foul air that may be released to the atmosphere along the high points of the force main alignment from the Morena Pump Station to the NCWRP. The proposed odor control methods and strategies are similar to what the City currently uses at the existing large sewage pump stations. The odor control system that removes and treats foul air at the Morena Pump Station utilizes negative pressure to change out the air in the screening and pump station buildings 20 times every hour. This process ensures that the air surrounding the wet well at the pump station and the air in the screening building is suitable for people to safely enter these facilities to perform any required maintenance activities.

3.6.2 NORTH CITY PURE WATER FACILITY

Operations for the NCPWF are discussed below.

Treatment

The NCPWF Influent Pump Station would convey tertiary effluent from the NCWRP to the NCPWF, where additional treatment processes would be required to produce the purified water.

The major process components of the NCPWF include MF and/or UF, RO, and UV/AOP (see Figure 3-27, Pure Water System Overview San Vicente Reservoir Alternative). In addition, the NCPWF-MR would provide additional stages of treatment, including an ozone system and BAC process (see Figure 3-28, Pure Water System Overview Miramar Reservoir Alternative) to ensure product water meets certain levels of log removal for *Cryptosporidium*, *Giardia*, and viruses as required by the State Water Resources Control Board Division of Drinking Water. Each of these processes is described below (MWH Americas et al. 2016):

Ozone System (Miramar Reservoir Alternative Only)

The ozone system will provide disinfection to achieve the log-removal credits for that unit process and chemical oxidation to reduce constituent of emerging concern (CEC) concentrations and facilitate biological treatment by BAC filters. The controlling factor for the design of the ozone system is achieving 1-log inactivation of *Cryptosporidium*, which requires a CT (residual concentration x contact time) of 3.8 milligrams per minute per liter (mg-min/L) at a temperature of 20.5 degrees Celsius (°C). Components of the ozone system include the LOX system, ozone generators, ozone dissolution and contactor, ozone off-gas destruction, and instrumentation and controls. Combined with BAC, ozonation will also improve membrane filtration performance beyond what could be achieved without this pretreatment. A total of two ozone contactors, three ozone generators, two LOX tanks, three vaporizers, and required auxiliary systems will be provided. There are three distinct ozone facilities on site:

- **LOX facility:** The LOX facility contains two vertical LOX storage tanks, three vaporizers, a pressure regulating station, a truck fill-station with a concrete apron for truck deliveries, and associated pipes and valves. All the equipment is mounted on a concrete slab north of the eastern parking lot and south of the chemical storage facility.
- **Ozone generation system:** The ozone generation system includes three ozone generators, three power supply units (PSUs), a particulate filter skid, a fine-pressure regulating station, a nitrogen boosting system, a cooling water system, and associated valves and piping.
- **Ozone injectors and contactors:** This system contains six ozone sidestream injection skids, six sidestream injection pumps, two ozone contactors, three ozone destruct units, three cooling water pumps (open loop), an ozone

residual sampling system with residual analyzers, and associated valves and piping (MWH Americas et al. 2016).

Biologically Active Carbon Filters (Miramar Reservoir Alternative Only)

The ozone process will be followed by biological filtration using GAC, also known as BAC filtration, to provide additional treatment before the MF system. Biological filtration is a fixed-film biological process that uses filter media as the surface for biological growth. With BAC, the GAC filter media is important mainly because its micro- and meso-porosity make it conducive to biofilm growth. This GAC is not regenerated, leading to the slow exhaustion of its adsorption capacity and making BAC a *biological* and *filtration* process rather than an *adsorption* process. During the filtration cycle, BAC removes both dissolved organics and suspended solids from the water by a combination of biological uptake and depth filtration. As the filtration cycle continues, biomass growth and suspended solids entrainment create additional head loss in the filter bed. The backwash cycle is then used to flush out the entrained solids and slough off some biomass from the media, thereby controlling the rate of biomass growth.

BAC filtration downstream of ozonation of tertiary effluent is provided for the removal of total organic carbon, N-Nitrosodimethylamine, and CECs. Ozonation increases the bioavailability of organic molecules by breaking them down, allowing BAC filtration to readily remove these organic molecules (MWH Americas et al. 2016).

Membrane Filtration

The MF treatment system will remove particulate matter from the RO feed water that would otherwise foul the RO membranes. The MF process is expected to achieve 4-log removal of *Cryptosporidium* and 4-log removal of *Giardia*; it is not being relied upon for virus removal.

The MF design will use hollow-fiber pressurized microfiltration or ultrafiltration membrane systems. The design uses membrane systems from Toray (packaged by H2O Innovation) and Pall because those systems have been prequalified for pre-selection testing. Both the Toray and Pall MF systems have been approved by the state, as California DDW certification was a requirement in the prequalification documents. Differences between suppliers include the size, type, and number of membrane modules and skids; ancillary equipment and chemicals used; and other system components. Final selection of the MF system will be determined with pre-selection testing and a present-worth-based selection process and assigned bids.

The MF process includes pretreatment with automatic strainers upstream of the membrane modules. The feed water to the MF system is pumped from the MF feed tank. During filtration mode, water will pass through the automatic strainers and the membrane modules and will discharge into the RO feed tank. The MF system also has backwash, cleaning, and direct integrity testing (DIT) cycles that individual racks will go through during operation. Ancillary systems to support the MF system operation include backwash pumps, air scour blowers, enhanced flux maintenance (EFM)/clean-in-place (CIP) and neutralization tanks and pumps, and a compressed-air system. The system will be controlled by a master programmable logic controller (PLC) provided by the MF supplier (MWH Americas et al. 2016).

Reverse Osmosis System

The RO process removes a significant portion of the dissolved solids, organics, and pathogens that remain after the MF system. For potable reuse applications, RO is critical for salinity control—it allows finished water to be within the desired range for TDS even with high-TDS source feed water, and prevents the accumulation of salts that would occur at a system-wide level without a flux of dissolved solids out of the system. The brine from the RO system is discharged to a location downstream of the Morena Pump Station intake diversion structures to prevent recirculation. RO is also vital for the removal of total organic carbon.

Overall operation of the RO system includes the following steps:

1. The plant operators confirm the feed water quality and the available flow for NCPWF to treat. They coordinate with the staff at NCWRP before making changes to the NCPWF flow rate.
2. Based on the above, the operators select a number of Production RO skids and Recovery RO skids on line for the amount of product water that is to be produced.
3. The plant control system calculates the required total RO feed flow based on the selected skid configuration and brings the RO transfer pumps on line. The cartridge filters are also brought on line.
4. Strong acid and antiscalant are dosed downstream of the RO transfer pumps. The RO feed pH is kept between 6.2 and 6.7, and the operators select the proper antiscalant dose based on the particular antiscalant product and the selected target feed pH.

5. Each Production RO skid runs on a constant feed flow and recovery set point. Each skid will monitor its own feed, permeate, and concentrate flow rates and calculate its own recovery on-board. Each skid adjusts its own Production RO feed pump and concentrate valve to achieve the set points.
6. Each Recovery RO skid runs on a constant feed flow and recovery set point. Each skid will monitor its own feed, permeate, and concentrate flow rates and calculate its own recovery on-board. Each skid adjusts its own Recovery RO feed pump/ERD and exhaust/bypass valves to achieve the set points.
7. Permeate from the Production RO skids and the Recovery RO skids flows into a combined permeate header. Concentrate from the Recovery RO skids flows from the Recovery RO concentrate header to the brine/concentrate line.

Advanced Oxidation (Ultraviolet plus Oxidant)

The UV/AOP system will be used to generate hydroxyl radicals to facilitate oxidation of organic compounds. This process will also be used to achieve an additional 6-log inactivation/removal of viruses *Giardia* and *Cryptosporidium* from the product water stream.

The UV/AOP system will be fed from permeate flows from the Production RO trains and Recovery RO trains. In the 30% design, the effluent from the UV/AOP system was shown flowing to the RO break tanks below the UV facility (MWH Americas et al. 2016). Following design progression, the effluent from the UV/AOP system will flow to the product water tank located to the north of the process building. HOCl will be used as the oxidant to generate the hydroxyl radicals. The selection of HOCl as an oxidant is based largely on industry research and UV manufacturer bench-scale analysis. The system layout would include a header pipe (located in the process building basement) will convey the combined ROP flows to the UV process area. Sufficient pipe length will be provided in the header pipe upstream of the individual UV reactors to ensure a stable flow. Turbulent flow into the UV reactors will impact the ability of the UV light to pass through the water column. The pipe length upstream of the UV reactors also provides the necessary upstream/downstream distances for the combined ROP flow meter. Chemical dosing for NaOCl and H₂SO₄ will be injected in the header pipe. Influent flow to the individual reactor trains is provided from lateral piping off of the ROP header. Individual flow meters are located along the straight run of the influent piping for each individual UV reactor in the process building basement. The lateral pipe lengths are sized to account for the necessary upstream/downstream distances for the flow meters.

The influent piping for the individual reactor trains then passes up through the process building floor to the ground floor level before connecting to the influent side of the UV reactor.

Flow passes through the individual UV reactors where hydroxyl radicals produced by the photolysis of HOCl facilitate oxidation of organic compounds. Motorized inlet and discharge valves are included with each reactor for isolation and control of each individual process train. UV reactor effluent piping is routed from the individual reactors up to a combined effluent header above the UV process area. The vertical run of piping serves to ensure that the UV reactors are always flooded when in operation. The UV effluent header piping then passes through the north wall of the process building and is routed to the product water tank.

Product Water Conditioning

After RO treatment, the low total dissolved solids (TDS) and low pH water must be stabilized to reduce its corrosive nature as it is conveyed from NCPWF to Miramar Reservoir. Carbon dioxide (CO₂) addition lowers the pH and encourages carbonate alkalinity production from lime addition. Lime addition increases alkalinity, pH, and hardness. NaOCl break-points any remaining chloramine and maintains a HOCl residual in the distribution system to Miramar Reservoir. A product water tank with the following configuration will be used for storing RO flush water and for product water stabilization:

- RO flush tank
- CO₂ injection box
- Two lime injection boxes
- Pump wetwell
- Overflow box
- Hypochlorite in-line injection

Distributed Control System

The NCPWF will be monitored and primarily controlled through an extension of the City's COMNET Distributed Control System (DCS). The components of the control system will match those of the Emerson Process Management Ovation DCS deployed throughout all of the City's conveyance and treatment facilities.

The DCS at the NCPWF will be physically connected to the existing COMNET DCS at the NCWRP through redundant single-mode fiber optic cables that are routed underground from the NCWRP secondary clarifiers control building root and backup root network switches using different routes to new primary and partner fan-out network switches located in the NCPWF server room. A single (non-redundant) process historian located at the O&M building network would augment the existing NCWRP historian.

The NCPWF O&M building control room will be the location for one set of fan-out switches, with another set located in the process building electrical room, and a final set located at the North City Pump Station. Although NCPWF is physically connected to NCWRP and will be part of the NCWRP domain, the two facilities will operate independently with separate operations staff for the two facilities. The one exception is that the NCPWF operators will have control and monitoring capability over the NCPWF Influent Pump Station located within NCWRP that feed the NCPWF.

Within NCPWF, the O&M building control room, process building electrical room, and North City Pump Station will each have DCS workstations with login interface that will be used by local operators to control the unit process in that specific area of the facility, but will also have the ability to control all processes within the facility based on the login credentials of the individual accessing the system. Each of the workstations will be connected directly through fiber-optic cable to the primary and partner fan-out switches for redundancy and reliability purposes.

Chemical Storage

For the NCPWF, hazardous materials are to be stored in chemical tanks housed in a chemical storage containment area. The chemical storage area is designed to comply with the International Fire Code (incompatible chemical storage vessels are isolated by at least a 20-foot distance). Each chemical area is isolated from the others, and for each one secondary containment is provided to contain at least 110% of the volume of the largest chemical tank plus a 24-hour, 25-year storm event. This volume is provided as part of the chemical storage structure; grating will allow O&M staff to walk above the liquid surface in case of a tank failure.

All of the chemical unloading areas are located on the same side of the building. A distinct splash area for incompatible chemicals should be provided with sumps, and constructed of concrete. Drip sumps (properly coated) and drains will be placed below the truck connection points. The drains will discharge directly into the

chemical storage containment area. Hose bibs should also be provided near unloading and chemical storage areas for washdown.

The chemical pumps will be located beneath a canopy for weather protection. All hazardous chemicals will be conveyed via double contained piping. The following chemicals will be stored in tanks located in a secondary containment structure: Sodium hypochlorite, aqueous ammonia, antiscalant, sulfuric acid, citric acid, sodium hydroxide, sodium bisulfite, lime, carbon dioxide, liquid oxygen, ozone, and proprietary membrane cleaning chemicals.

Power Outages

The NCPWF is not an essential facility. In the rare event of simultaneous failure of the power generation facility at NCWRP and utility power, the majority of NCPWF will be shut down and flow to NCWRP will be reduced to meet Title 22 flows. Remaining raw sewage will be diverted to the Point Loma WWTP.

RO MCC-2 will have emergency power via a standby generator for the ability to continue flushing the process lines to prevent buildup within the pipe. The generator is sized for operating two RO flush pumps and 45 kilovolt-amperes of miscellaneous loads.

Each DCS, PLC, and remote IO cabinet as well as 120-volt alternating current powered instruments will be supplied power from a localized uninterruptible power supply system with a recommended backup time of 4 hours.

Failsafe Features

Measures for Pathogen Control and Off-Specification Water Monitoring

The NCPWF has been designed to consistently achieve pathogen log reduction values in excess of the minimum log reduction that would be required. With this design strategy, the NCPWF will have a buffer so that even if an individual process or monitor fails, the facility will not generate off-spec water.

Use of SCADA in the Critical Control Point Management Process

Using monitoring data for flow and for surrogates at all the critical control points (CCPs), supervisory control and data acquisition (SCADA) will be used to continuously calculate and display the performance of the plan in meeting its performance goals. Each surrogate for each CCP will be separately displayed and,

using colors and flashing lights, SCADA will provide operational staff with a clear picture of the status of NCPWF as a whole as well as each CCP. Operators will know where they stand at all times.

Facilities for Diversion of Off-Specification Water

The proposed advanced water purification facility treatment train contains multiple and redundant treatment processes, redundant water quality monitoring equipment, and conservative design specifications that will ensure treatment reliability and compliance with applicable water quality standards. In the unlikely event that major treatment and monitoring processes simultaneously fail, however, it is possible that water not meeting the specified log removals, or “off-spec” water, could be produced.

As a first level of public health protection against such off-spec water, the supply of Miramar Reservoir water to the Miramar WTP would be cut off, and water treatment plant operations would rely on imported aqueduct water until the off-spec problem was corrected and it was demonstrated to regulators that reservoir water could again be directed to the filtration plant. If the cause of the off-spec water cannot be immediately rectified, conveyance of advanced water purification facility water to the reservoir would be suspended, and advanced water purification facility water would be directed to the sewer for treatment at the Point Loma WWPT and ocean discharge.

In the event the off-spec issue is sufficient to warrant no discharge of the pipeline water to the reservoir, the off-spec water would be diverted from the pipeline for disposal or reuse. The following proposed strategies for off-spec water disposal were developed based on the following goals:

- Provide barriers to protect public health.
- Minimize required facilities to reduce project costs.
- Minimize the conveyance system out of service time to bring the NCPWF back on-line as quickly as possible.
- Develop preferred disposal options based on listed criteria such as available time, reducing water loss, etc.

Three options have been developed to provide operational flexibility for O&M staff to dispose of off-spec water in the very unlikely event that off-spec water leaves the NCPWF, enters the North City Pipeline, and the off-spec issue is sufficiently significant to warrant disposal of the off-spec water in the pipeline. The three

options utilize the closure of an isolation valve downstream of the Dechlorination Facility to prevent off-spec water from entering Miramar Reservoir.

Option A – Disposal of Off-Spec Water to NCPWF Waste Discharge Pipeline

Option A has been designed to drain back the North City Pipeline thru the North City Pump Station discharge header controlled by a pressure control valve plumbed to a 24-inch pipeline connected to the 48-inch NCPWF Waste Discharge Pipeline, which has the capacity to drain 42 MGD. The North City Pipeline will drain back utilizing the elevation head in the pipeline. Localized low points will be manually pumped out of the North City Pipeline and into adjacent sanitary sewers. This option will require the temporary shut down and closure of the North City Pump Station. Option A is best suited in a situation where disposing of off-spec water and the commencement of the production of on-spec water from the NCPWF will take more than a few hours and longer than the drain time of the North City Pipeline, which can be up to 9 hours and 37 hours to manually drain low points along the North City Pipeline.

Option B – Disposal of Off-Spec Water to Existing Carrol Canyon Trunk Sewer at Via Pasar

Option B has been designed to push the volume of off-spec water out of the North City Pipeline into the existing Carrol Canyon Trunk Sewer via an above-grade discharge pipe into an existing sewer manhole. This option will require the North City Pump Station to pump at lower flow rates and monitor the capacity of the Carrol Canyon Trunk Sewer at Manhole 223, located 1,850 feet west of the intersection of Camino Ruiz and Carroll Canyon Road. In addition to the closure of the isolation valve downstream of the Dechlorination Facility, an additional closure of the isolation valve located at Via Pasar will be required to isolate the eastern portion of the subaqueous pipe from the North City Pipeline. Option B is not recommended during wet weather conditions. The travel time within the North City Pipeline from the North City Pump Station to the Via Pasar above-grade discharge pipe is 2 hours when the North City Pump Station is operating at maximum design flow (32.8 MGD). This option is suited for scenarios where the production of on-spec water is within a few hours, and operators are looking to dispose of the segment west of Via Pasar of off-spec water during dry weather conditions.

Option C – Disposal of Off-Spec Water to Existing Meanley Drive Storm Drain System

Option C has been designed to push the volume of off-spec water out of the North City Pipeline, into an existing 18-inch storm drain located in Meanley Drive. Information gathered from the existing storm drain system as-builts and a hydraulic analysis indicated adequate capacity to accommodate the full flow of the North City Pump Station. However, this option will require North City Pump Station to pump at lower flow rates and monitoring of the capacity of the existing storm drain system on Meanley Drive, Hoyt Park, and Scripps Ranch Court, as well as the need to monitor that no erosion occurs at the outlet of the existing storm drain at the west end of Scripps Ranch Court. Operators will also coordinate with the City's Transportation and Storm Water Department, particularly during a rain event. This option involves the following requirements:

- A National Pollutant Discharge Elimination System permit;
- Water quality compliance monitoring; and
- Compliance with applicable surface water quality standards

Furthermore, the following may also be required:

- Energy dissipation/erosion controls or flow throttling facilities; and
- U.S. Army Corps of Engineers Streambed Alteration Permit.

The travel time within the North City Pipeline from the North City Pump Station to the Dechlorination Facility is 2 hours and 30 minutes when the North City Pump Station is operating at maximum design flow (32.8 MGD).

3.7 ALTERNATIVES CONSIDERED BUT NOT CARRIED FORWARD FOR ANALYSIS

3.7.1 PREVIOUS WATER SUPPLY ALTERNATIVES PLANNING

The City has a long history of evaluating water supply alternatives. Over the past decade, potable reuse options have been extensively studied and weighed along with other water supply options. As part of a balanced approach to water supply portfolio diversification, no single water supply option is considered to be “preferred.” Rather, the study of water supply alternatives has included broad-based considerations of feasibility, environmental considerations, and costs. For reuse options, specific focus has been given to the various options involved in

implementing new and enhancing existing reuse practices. The following provides a summary of the City's recent water supply planning efforts, which form a basis from which alternatives to the North City Project were considered for purposes of this EIR/EIS. Specifically, the City's extensive planning and broad stakeholder-driven processes in developing options that ultimately led to definition of the Pure Water Program provide the basis for alternatives that were considered and rejected through the planning process—all of which has undergone extensive public participation.

Long-Range Water Resources Plan

The Long-Range Water Resources Plan (LRWRP) was developed in 2012, and is a high-level strategy document intended to provide information to decision makers regarding the tradeoffs of future water resource investments, with a long-range viewpoint through the year 2035 planning horizon (City of San Diego 2013). The 2012 LRWRP evaluates water supply and conservation options with consideration of multiple planning objectives. The plan was developed using an open, participatory planning process, with input from a dedicated Stakeholder Committee. The outcome of the 2012 LRWRP is a flexible and adaptive implementation strategy that accounts for future risk and uncertainty.

The City developed its first LRWRP in 2002, which provided direction for the City to pursue additional conservation, recycled water, and groundwater, with consideration of implementing potential water transfers, marine transport, and ocean desalination options if warranted. The City decided to update the plan in 2012 in light of the following changed conditions since adoption of the 2002 LRWRP:

- Metropolitan Water District of Southern California/San Diego County Water Authority imported water reliability issues surrounding the Sacramento–San Joaquin Delta and Colorado River, especially in the areas of the Endangered Species Act
- Climate change and its potential impacts on water demands and supplies
- New approaches and public support for potable reuse, using advanced purification of recycled water
- Viability of water transfers, marine transport, and ocean desalination

As such, the 2012 LRWRP reassessed planning objectives and stakeholder values, evaluated emerging issues, and used the most recent information available at that

time to determine a long-term water resources strategy for the City. The 2012 LRWRP used projected water demands, imported water availability, and costs; it also evaluated new supply opportunities that were not considered in the 2002 LRWRP.

The 2012 LRWRP identified three options for potable reuse for a total projected yield of up to 93,000 acre-feet per year (AFY; 83 MGD) (City of San Diego 2013). A total of 20 additional options were identified as alternatives to imported water in the categories of conservation; groundwater development; non-potable recycled water; and rainwater harvesting, graywater, and ocean desalination. Because the goal of achieving a balanced portfolio of water supply involves weighing numerous factors among various alternatives, the LRWRP process included an evaluation and ranking of portfolios to show the relative trade-offs among performance measures. The LRWRP Objectives were defined as follows (City of San Diego 2013):

- Provide Reliability and Robustness
- Manage Cost and Provide Affordability
- Maximize Efficiency of Water Use
- Provide for Scalability of Implementation
- Maintain Current and Future Assets
- Provide for Local Control/Independence
- Maximize Project Readiness
- Protect Quality of Life
- Protect Habitats and Wildlife
- Reduce Energy Footprint
- Protect Quality of Receiving Waters

As a result of the alternative water supply evaluation process, the LRWRP recommended implementation of strategies that included the following (City of San Diego 2013):

- Additional Active Conservation – 20,900 AFY (18.7 MGD)
- Rainwater Harvesting – 420 AFY (0.38 MGD)
- Groundwater Supply – up to 4,000 AFY (3.6 MGD)
- Potable Reuse (for all three phases) – 93,000 AFY (83 MGD)

The North City Project implements a portion of the Pure Water Program, which was developed from recommendations from the 2012 LRWRP to include potable reuse as one of multiple recommended strategies to complement the City's ongoing pursuit of planned water supply options.

Water Reuse Study

On January 13, 2004, the San Diego City Council directed the City Manager to conduct a study to evaluate options for increasing the beneficial use of the City's recycled water. As part of the planning process, the study team developed an objective and a mission statement for the project, which set forth parameters for an impartial, balanced, comprehensive, and science-based study of all recycled water opportunities to increase local water supply and reliability, and optimize local water assets. As such, the study represented the first step in the City's comprehensive consideration of alternatives to optimize recycled water.

The process used to develop the study started with the City assembling a diverse, participatory group that included stakeholders and noted specialists in the fields of science, technology, health and safety, and economics. Two key groups convened shortly after the project began: a stakeholder workshop, called the City of San Diego Assembly on Water Reuse (Assembly), and an Independent Advisory Panel (IAP). The City selected its 67 Assembly participants through a City-wide search for key stakeholders such as community leaders, policy makers, water consumers, business leaders, and professionals in various fields of expertise. The IAP was established to provide independent oversight and guidance to the study team. IAP panel members were contracted through the National Water Research Institute, which was selected to ensure an unbiased and thorough examination of all possible water reuse opportunities. These two groups worked with City staff and consultants to develop and review and finalize the Water Reuse Study.

The following is an excerpt from the IAP's findings at the conclusion of the process:

It is the unanimous conclusion of the Panel [IAP] that appropriate alternative water reuse strategies for the City of San Diego have been identified, and that these alternatives have been presented clearly so that the citizens of the City of San Diego can make informed choices with respect to water reuse.

The analysis consolidated a combination of reuse opportunities, which are referred to as "strategies." The strategies represent a set of diverse reuse options for both

the North City and South Bay systems. Decision charts, which can be used as roadmaps for each strategy's implementation, were included to summarize facilities and reuse volumes and were developed to help answer the primary study questions of (1) which water recycling opportunities to pursue, and, (2) depending on the opportunity, how much water to recycle. Supporting text included the benefits of each strategy, the value of recycled water, detailed costs for each strategy, and information on other water supply options.

The study resulted in an evaluation of six strategies integrating non-potable reuse and potable reuse opportunities for the North, Central, and South potable water service areas. A potable reuse project using the City's San Vicente Reservoir through a concept known as "reservoir augmentation" was identified as the preferred reuse strategy. This concept formed the basis of the North City component as analyzed in the Pure Water Program EIR (City of San Diego 2016a).

Recycled Water Study

The Recycled Water Study (City of San Diego 2012) followed the 2006 Water Reuse Study, with the objective of finding ways to maximize system-wide reuse and developing integrated reuse alternatives that the public and policy makers could review and select from to guide the future of the reuse program located within the Metro System Service Area. The alternatives were evaluated to meet City, participating agency, and project stakeholder reuse goals through a 2035 planning horizon, and were part of a comprehensive regional program to evaluate and develop water reuse in San Diego.

The Recycled Water Study was initiated with a broader basis than the 2006 Water Reuse Study: to consider the water reuse goal to be limited only by the amount of wastewater available in the Metro System Service Area. This was a more comprehensive goal, providing the potential to reuse 10 times more water than previous targets, with approximately 200 MGD projected to be available in the Metro System Service Area on an average dry weather year in 2035.

The study included a number of technical evaluations and coordination steps to identify and evaluate reuse alternatives within the City as well as areas served by the participating agencies. Throughout the study, regular stakeholder status update meetings were held to present progress and to receive input and feedback on the activities. Eight technical memoranda were developed to document information. Alternatives were developed through a participatory process, with stakeholder

status update meetings and five work sessions that were used to frame, develop, refine, and communicate the alternatives included in this study.

“Area Concepts” were developed to provide detailed, comparable alternatives for discussion at a “Coarse Screening Session” and stakeholder status update meetings, and were then refined and compiled into Integrated Reuse Alternatives. The Area Concepts were strategically selected, based on the locations of available wastewater, existing facilities, and delivery points (non-potable recycled water customers, surface water reservoirs, or groundwater basins). Eleven reservoirs were originally evaluated based on their size, proximity to infrastructure (which relates to cost), ability to integrate with existing water treatment plants, anticipated characteristics related to regulatory compliance, and institutional complexity. The San Vicente Reservoir, Otay Lakes, and Lake Hodges were advanced as candidate indirect potable reuse opportunities. Lake Murray and Miramar Reservoir were considered too small to meet anticipated regulatory requirements at the time; however, potential project sizes were calculated for these two reservoirs as well since they are located at the two largest water treatment plants in the Metro System Service Area.

Regional groundwater basins were also considered for additional opportunities for indirect potable reuse. However, evaluations confirmed that groundwater recharge opportunities in San Diego County are more limited than reservoir augmentation due to the size, yields, and characteristics of the local groundwater basins. Groundwater basins were eliminated from consideration based on a variety of reasons, including infrastructure needs leading to higher costs, small size, water quality issues, liquefaction potential, and institutional complexity.

Opportunities were sized and then pieced together by laying out treatment and conveyance facilities. Cost information was also developed, with pumping costs being a particularly important component because of the variability of pumping costs for potable reuse using reservoir augmentation, non-potable water, and wastewater. The availability of this information allowed stakeholders to compare the benefits of different approaches within each area. For example, alternatives that required extensive wastewater pumping (which requires pumping approximately 30% more flow than advanced treated water), were identified as having added costs and risks compared to other alternatives. This point led to development of the Harbor Drive Plant concept later in the study. Area Concepts were refined into Integrated Reuse Alternatives in the “Fine Screening Session.” Fine Screening Session participants considered a series of projects to meet the 100 MGD water reuse target.

Five Integrated Reuse Alternatives were developed based on the extensive, interactive Stakeholder process. Each alternative includes 83 MGD of new potable reuse and 3 MGD of new non-potable recycled (in addition to 4 MGD of already planned non-potable reuse).

City of San Diego Urban Water Management Plan

The City's 2015 Urban Water Management Plan meets the State of California's requirements under the California Water Code and complies with the California Urban Water Management Planning Act, as well as serves as an overarching water resources planning document for the City (City of San Diego 2016b). The 2015 UWMP details the City's water system, water demands, sources of water supplies, water conservation efforts, climate change impacts, energy intensity, water shortage contingency planning, and projected water supply reliability during normal, dry, and multi-year drought conditions.

The 2015 UWMP identifies current and planned future water supplies, and identifies potential, conceptual future water supplies that the City may implement. Based on the results of the 2012 LRWRP and 2012 Recycled Water Study, the 2015 UWMP identifies both verifiable water supply sources (surface water, groundwater, and recycled water (non-potable)), as well as conceptual water supply sources (the City's Pure Water Program, future groundwater projects, and rainwater harvesting and greywater).

Summary of Water Supply Alternatives Consideration

As summarized in this section, the City's evaluation of water supply alternatives over the past decade or more has focused on reducing dependence on imported water supplies, and has ranged from broad-based options for generating new supplies, to more focused studies on implementing specific supply options, such as reuse. Various options and concepts that were included among those studies and evaluation processes are alternatives that were considered and rejected. Included among those are alternatives relating to increasing non-potable recycled water use and updating Point Loma WWTP to full secondary treatment, both of which were considered and rejected in the Water Reuse Study and the Recycled Water Study.

The Recycled Water Study built on past efforts in defining supply options, by providing detail on facility needs to achieve the reuse supply targets. The North City Project comprises the facilities necessary to move a portion of the Pure Water

Program identified reuse options into an implementation stage, and represents the outcome of the City's deliberative efforts to diversify the City's water supply portfolio.

3.7.2 CURRENT ALTERNATIVES SCREENING

The screening process used in the EIR/EIS to evaluate a reasonable range of alternatives was based on the North City Project's purpose and need/objectives (Chapter 1). A number of alternatives were considered, but not carried forward for detailed analysis in the EIR/EIS. A wetlands avoidance alternative was considered but no technically feasible alternatives that met the purpose of the North City Project could be determined. An electrical transmission line alternative was considered, which would have generated power at MBC and transferred it to the North City Project via an electrical transmission line to the NCWRP. Additionally, the Project team considered numerous alternative alignments and routes for each of the purified water pipelines and the Morena Pipelines.

Wetlands Avoidance Alternative

Impacts to wetlands have been avoided to the extent practicable within the Project Alternatives; with only 0.38 acre of permanent impacts out of the total 207 acres of impacts attributable to wetlands under the Miramar Reservoir Alternative. All permanent impacts to wetlands under the Miramar Reservoir Alternative would occur at the NCPWF site.

There is a substantial increase in efficiency to locating the NCPWF adjacent to the NCWRP. By locating the NCPWF adjacent to the NCWRP, less energy is required to pump recycled water from the NCWRP to the NCPWF, which thereby results in less greenhouse gas emissions. By locating the facilities adjacent to each other, staff and other O&M requirements can be shared. Other parcels adjacent to the NCWRP or along the North City Pipeline alignment were screened for suitability, including the Pueblo Central, Pueblo South, and MCAS Property immediately east of the NCWRP; however, all are either currently developed, are under the jurisdiction of MCAS Miramar, or contain more sensitive resources than the proposed NCPWF site (see Figure 3-29, Alternative North City Pure Water Facility Sites). There are no other feasible alternative NCPWF sites.

A Wetlands Avoidance Alternative has been thoroughly vetted by the Project team; however, due to the inherent nature of the Project, impacts to wetlands would be unavoidable. Therefore, this alternative is not carried forward for detailed analysis in this EIR/EIS.

Electrical Transmission Line Alternative

An electrical transmission line alternative was originally considered by the Project team. This alternative would have located a power generation facility at MBC and supplied power to the North City Project via an electrical transmission line. The electrical transmission line would have been approximately 4 miles, as compared to the LFG Pipeline which is approximately 3 miles, and therefore, would have resulted in more ground disturbance. The electrical transmission line also would have required a new easement through the VA Cemetery that would have resulted in greater impacts and loss of cemetery plots within the VA Cemetery, whereas the LFG Pipeline can be constructed within an existing easement through the VA Cemetery property. Additionally, the electrical transmission line would have resulted in overhead power lines being located on some portions of MCAS Miramar, thereby resulting in a potential hazard to military aircraft. An additional gas transmission line from the Miramar landfill to MBC would have been required. Therefore, due to the higher capital, O&M, and life-cycle costs and greater environmental effects, the electrical transmission line was not carried forward for detailed analysis in the EIR/EIS.

Pipeline Alignment Alternatives

During preliminary design of the Morena Pipelines, North City Pipeline, and San Vicente Pipeline, design teams studied a number of alignments for feasibility, cost effectiveness, resource avoidance, and risk. A number of factors were evaluated in determining the current alignment of pipelines. Factors considered include cost, schedule for construction, community disruption, traffic impacts, energy demand, impacts to environmentally sensitive lands, property and easement acquisition, utility conflicts, overall length of pipeline corridors, geologic conditions, constructability, and O&M considerations.

Morena Wastewater Forcemain and Brine/Centrates Line

The initial alignment for the Morena Pipelines was based on the Plant Siting and Pipe Alignment Study, dated February 2, 2015, prepared by Brown and Caldwell. Initial alignments included a Proposed Corridor and Alternate Corridor. The Proposed Corridor ran east along Balboa Avenue from a conceptual pump station location at Balboa Avenue and Morena Boulevard, then north along Genesee Avenue, east along Governor Drive, and north along the SDG&E utility corridor, crossing Miramar Road to the NCWRP and NCWPF (see Initial Alignments shown on Figure 3-30, Morena Wastewater Forcemain and Brine/Centrates Line Alternative Alignments).

During preparation of the 10% Design Report for the Morena Pipelines, the Proposed Corridor (Alternative Alignment No. 1) was refined and two alternative pipeline alignments were evaluated (see 10% Design Phase Alignments shown on Figure 3-30), including Alternative Alignment No. 2, which is approximately 9 miles and was designed to decrease community impacts; and Alternative Alignment No. 3, which is approximately 10.4 miles and was designed to decrease environmental impacts and be more hydraulically favorable (Appendix B of the 10% Design Report, MWH Americas and Brown and Caldwell 2016). Alternative Alignment No. 3 was identified as the preferred alignment for the Morena Pipelines and was elevated to the 10% Design Phase. During the 10% and subsequent 30% Design Phases, additional tweaks were made to the alignment, including bypassing the Morena Boulevard/Clairemont Drive intersection by following Ingulf and Denver Streets; removing the section along La Jolla Village Drive and instead following Nobel Drive to Towne Center Drive to Executive Drive; and moving the trenchless crossing of Rose Canyon out of the roadway ROW and placing the receiving pit just east of Genesee Avenue.

North City Pure Water Pipeline

Similar to the Morena Pipelines, three alternative alignments, along with various alignment deviations, were also evaluated for the North City Pipeline prior to advancing a preferred alignment to the 10% Design Phase (MWH Americas Inc. and Brown and Caldwell 2015). A study area bounded by I-805 to the west, Mira Mesa Boulevard and Scripps Ranch Boulevard to the north, MCAS Miramar and the Navy Operations Center to the south, and the existing water authority easements and Miramar Lake's eastern banks to the east was originally considered. Miramar Road was identified as the preferred route between the North City Pump Station and Black Mountain Road. Three alternative alignments were evaluated (Alternative A "North," Alternative B "Central," and Alternative C "South"; see Figure 3-31A, North City Pure Water Pipeline Alternative Alignments) between Black Mountain Road and Miramar Reservoir in addition to four initial study options and various alignment deviations. Table 3-4 discusses the impacts associated with each option and deviation.

**Table 3-4
Initial Alignment Alternatives and Deviations**

Map ID	Description	Impact
Initial Study Options		
1	Mira Mesa Boulevard	Reviewed as an alternative to Miramar Road. Route was eliminated due to heavy daily traffic counts, schedule restrictions working in residential areas, and avoidance of hard improvements and vegetation in the median.
2	Rock Quarry Sewer Easement	Reviewed as an alternative to Miramar Road. Route was eliminated due to environmentally sensitive areas bordering the quarry, planned development, waterways, and insufficient easement space.
3	Clean Water Act (CWA) Easement	Reviewed as an alternative between Pomerado Road and the Miramar WTP. Eliminated due to easement language restrictions – CWA facilities only.
4	Miramar Ranch School Easement on South & East boundary	Reviewed as an alternative to bypass Red Cedar Drive and CWA pipelines. Eliminated due to schedule restrictions, need to protect school facilities, and crossing on the CWA easement that crosses the property.
Alternative A (North)		
A1	Activity Road	Option to avoid MCAS Main Gate. Adds 200 feet to alignment overall length.
A2	Westview Parkway	Option to avoid Mira Mesa/Black Mount Road intersection.
Alternative B (Central)		
B1	Activity Road	Option to avoid MCAS Main Gate. Adds 200 feet to alignment overall length.
B2	Black Mountain Road & Kearny Mesa Road to Via Excelencia	Revision to remove 390 degrees or greater horizontal bends. Reduced overall Alternative Alignment B by 200 feet (included in Alternative B).
B3	Scripps Ranch Blvd & Carrol Canyon Road to Miramar WTP	Revision to avoid heavy utility congestion in Scripps Ranch Boulevard and Scripps Lake Drive. Reduced overall Alternative Alignment B by 900 feet (included in Alternative B).
B4	Miramar WTP East discharge at east end of Miramar Reservoir	Revision to reduce pumping head and overall length by 9,500 feet (included in Alternative B).

**Table 3-4
Initial Alignment Alternatives and Deviations**

Map ID	Description	Impact
Alternative C (South)		
C1	Scripps Ranch Boulevard & Aviary Drive to Red Cedar Drive & Ranch View Drive	Option to bypass Aviary Drive and Red Cedar Drive. Increases overall alignment by 100 feet.

Source: MWH Americas Inc. and Brown and Caldwell 2015

Alternative B was advanced to the 10% Design Phase (Appendix K of the 10% Design Report, Brown and Caldwell 2015).

Since the Alternatives Analysis in the 10% Design Phase, the North City Pipeline alignment has been further refined as part of the 30% and 60% design efforts. Rather than following Black Mountain Road to Kearny Villa Road to Carrol Center Road to Via Pasar and the crossing I-15 at the terminus of Via Excelencia across private property, the alignment now continues on Miramar Road to Kearny Villa Road, then follows Candida Street to Via Pasar to Via Excelencia. The I-15 crossing is still the same.

As described in the NC04B Pure Water Pipeline Alignment Alternatives (City of San Diego 2017b), Alternative B “Central” was chosen for having the most advantages, including the least impacts to residential areas; however, this alignment also had the principal disadvantage of requiring the most private commercial land easement acquisitions. As such, a number of alternative alignments have been considered for the portion of the North City Pipeline between Scripps Ranch Boulevard and Miramar Reservoir (see Figure 3-31B, North City Pure Water Pipeline Alternative Alignments).

A key consideration of the alignment analysis determined is the proposed location of the Dechlorination Facility, which is proposed on City property at the reclaimed water tank site located at the southeast end of Meanley Drive because it provides adequate contact time to properly remove chlorine from the pipeline prior to discharging into the reservoir. “Alignment A – Meanley Drive Alignment” follows Meanley Drive from Scripps Ranch Boulevard to the Dechlorination Facility and then continues via one of three routes to the reservoir: (1) Alignment A1 – APN 319-170-23, (2) Alignment A2 – APN 319-170-22, and (3) Alignment A3 – Scripps Ranch Branch Library Pathway. “Alignment B – Hoyt Park Drive Reroute” reroutes the North City Pipeline along Hoyt

Park Drive, which eliminates the need to tunnel under the crossing of the San Diego County Water Authority's 96-inch Aqueduct at Meanley Drive.

"Alignment C – Scripps Lake Drive Alternative" reconsidered routing the North City Pipeline from the Dechlorination Facility back to Scripps Ranch Boulevard, then east on Scripps Lake Drive to the Miramar WTP site before entering the Miramar Reservoir; however, utility congestion in Scripps Lake Drive (including a fiber optic line, SDG&E electrical, SDG&E electrical vault, City water pressure reducing station, and a San Diego County Water Authority facility not previously discovered in earlier research) limited available space for the North City Pipeline, which needs to meet specific separation requirements.

"Alignment D – Modified APN 319-170-23 Alternative" deviates from Alignment A1 originally analyzed across this property and follows the western boundary of the property within the existing paved parking lot. However, in addition to other constraints, this alignment raises the highpoint of the pipeline and results in increased motor requirements at the North City Pump Station, thereby increasing annual energy requirements. "Alignment E – Modified Alignment through KBS Ingress/Egress & Landscaped Area" follows a similar alignment to Alignment D, but just slightly to the west in the landscaped areas instead of the paved parking lot. This alignment reduces the need for higher motor requirements, but requires temporary construction easements within the Scripps Ranch Technology Park property, and maintenance access would be required through the easement.

"Alignment F – Modified Alignment within 20-foot-wide setback of Scripps Ranch Technology Park Parcel" deviates just slightly from Alignment A2 and maintains the North City Pipeline alignment within the 20-foot-wide setback and outside of the proposed future parking lot's estimated structural line of influence.

San Vicente Pure Water Pipeline

The San Vicente Pipeline alignment was originally vetted in the Recycled Water Study (City of San Diego 2012), which considered a number of alignments between both the NCPWF and a proposed Harbor Drive Plant and the San Vicente Reservoir (see Figure 3-32A, San Vicente Pure Water Pipeline Alternative Alignments). The alignment was significantly revised and refined in the 10% Design Phase, which considered nine different alignment revisions to the base alignment (see Figure 3-32B, San Vicente Pure Water Pipeline Alternative Alignments; Brown and Caldwell 2015). Specific reasons for realignment from the base alignment included: (1)

accommodating the High Pressure Scenario and abandoning a proposal to construct a new pipe parallel to the existing 36-inch Recycled Water Line, (2) avoidance of environmentally sensitive areas such as vernal pools along SR-52, (3) avoidance of congested utility corridor, (4) avoidance of contaminated soil, (5) potential impacts to traffic and commercial establishments, (6) anticipated difficulty in acquiring easements within federal property, (7) environmental considerations, (8) elimination of Deerfield Pump Station site from consideration for MTBS site due to impacts to park land, and (9) alignment issues for SR-67 crossing.

The process of selecting each pipeline alignment was made with careful consideration of environmental resources and with the intention to minimize potential impacts. As such, all feasible alignments were evaluated, and it has been determined that the proposed alignments would result in the least environmental impacts.

INTENTIONALLY LEFT BLANK

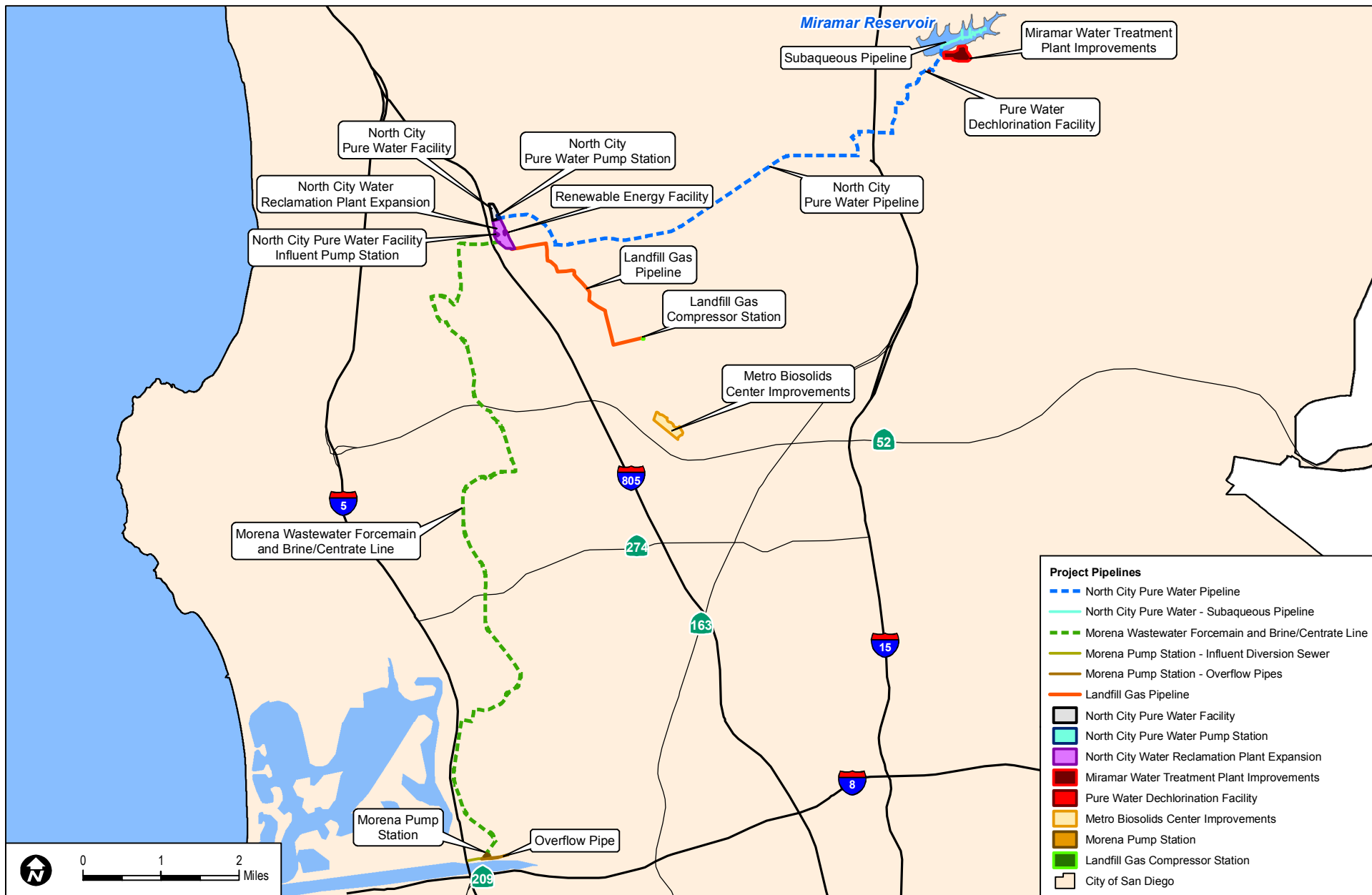

SOURCE: City of San Diego, 2015, 2016; SanGIS 2016

DUDEK

Pure Water San Diego Program North City Project EIR/EIS

FIGURE 3-1

Miramar Reservoir Alternative

INTENTIONALLY LEFT BLANK

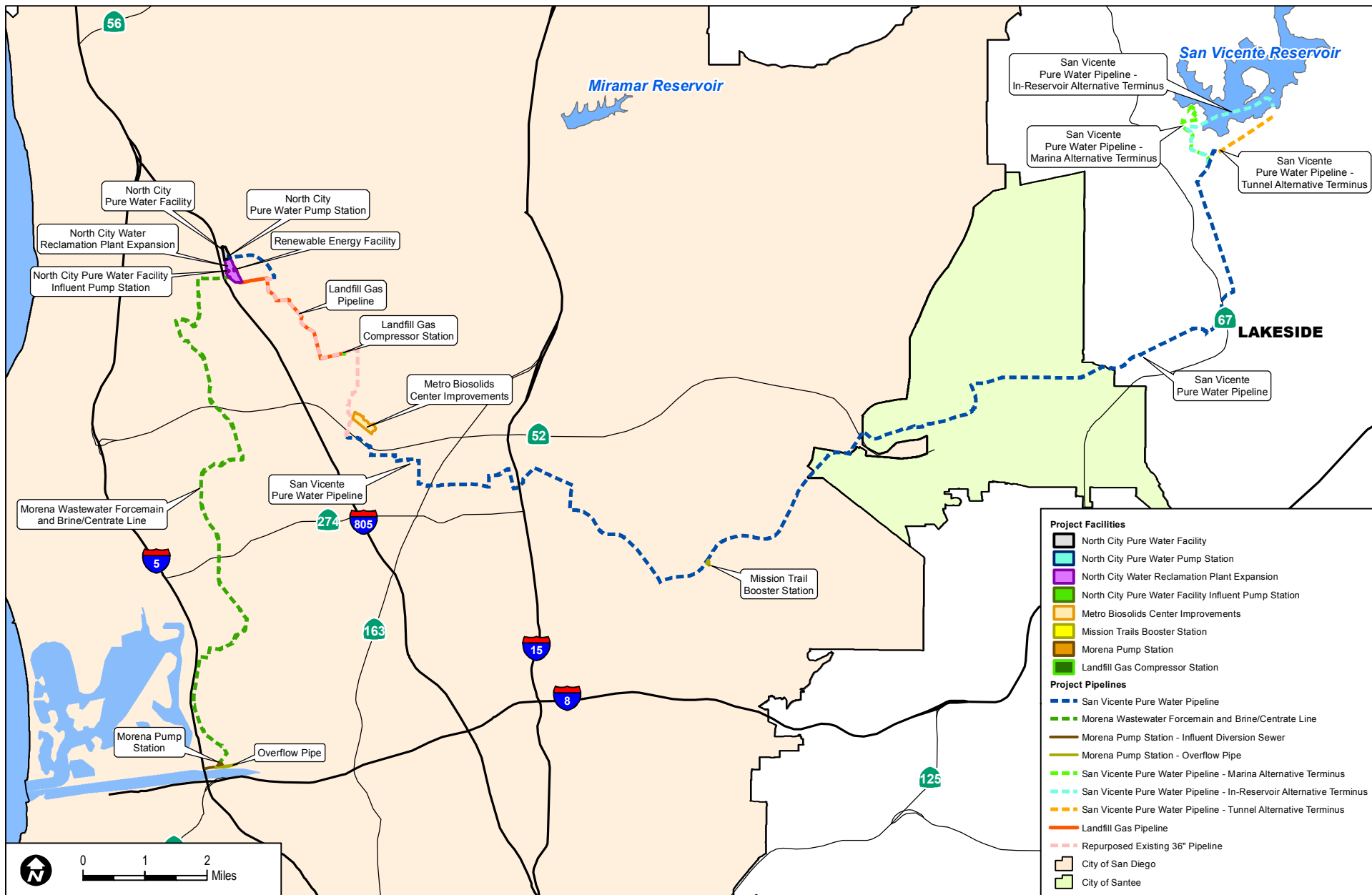

SOURCE: City of San Diego, 2015, 2016; SanGIS 2016

DUDEK

Pure Water San Diego Program North City Project EIR/EIS

FIGURE 3-2

San Vicente Reservoir Alternative

INTENTIONALLY LEFT BLANK

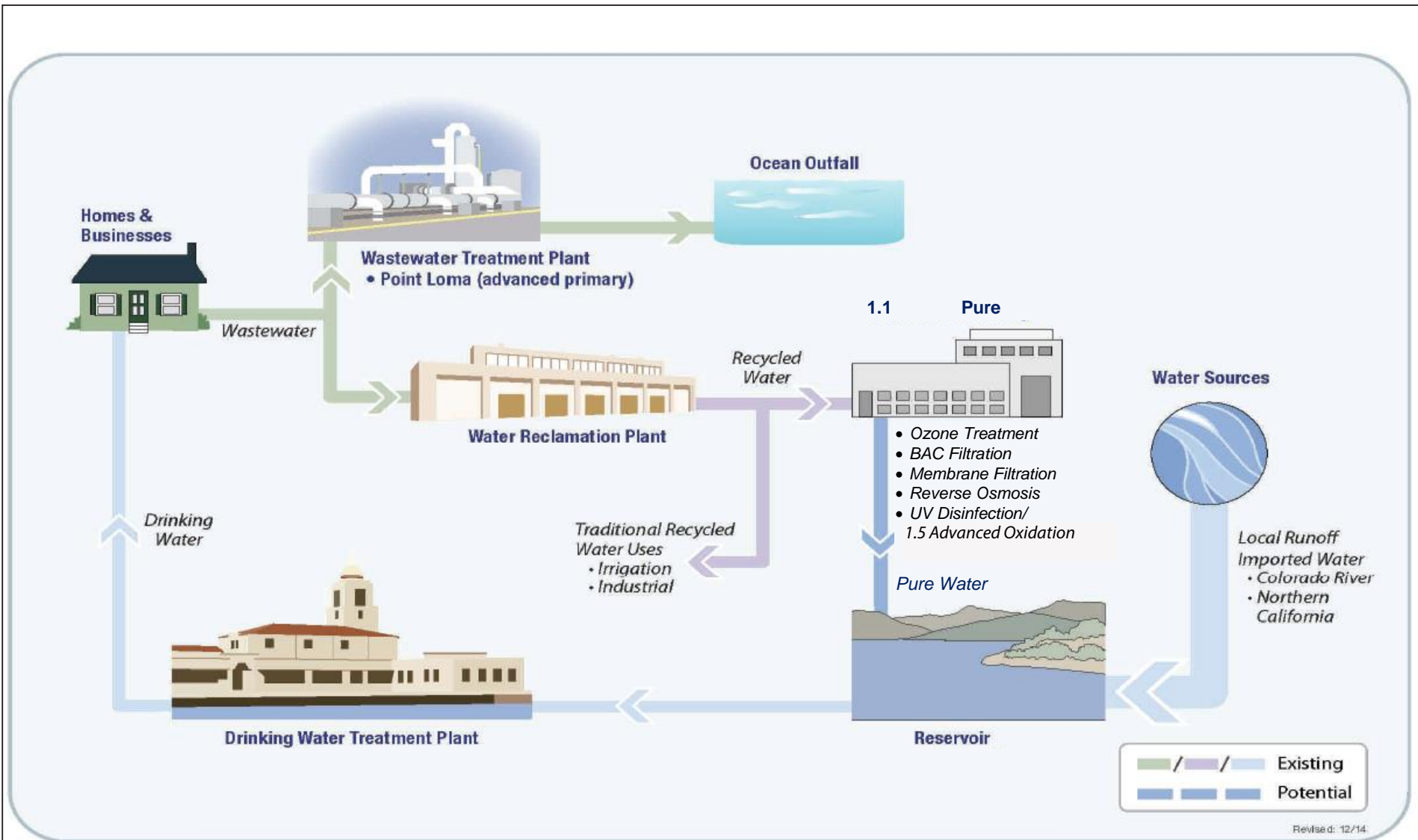

INTENTIONALLY LEFT BLANK

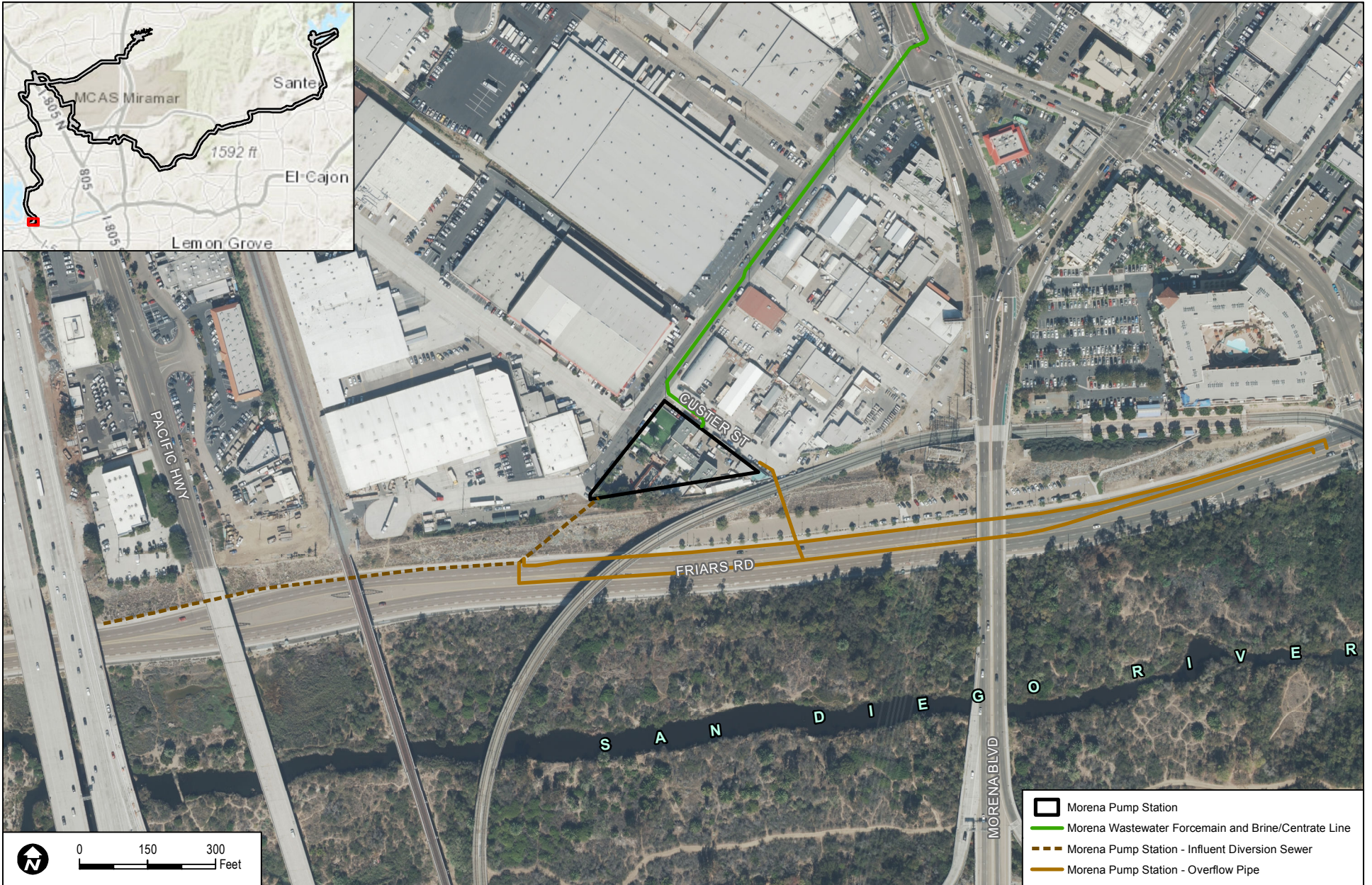

SOURCE: City of San Diego 2016, 2017, 2018; SANDAG

DUDEK

Pure Water San Diego Program North City Project EIR/EIS

FIGURE 3-4

Morena Pump Station Site

INTENTIONALLY LEFT BLANK

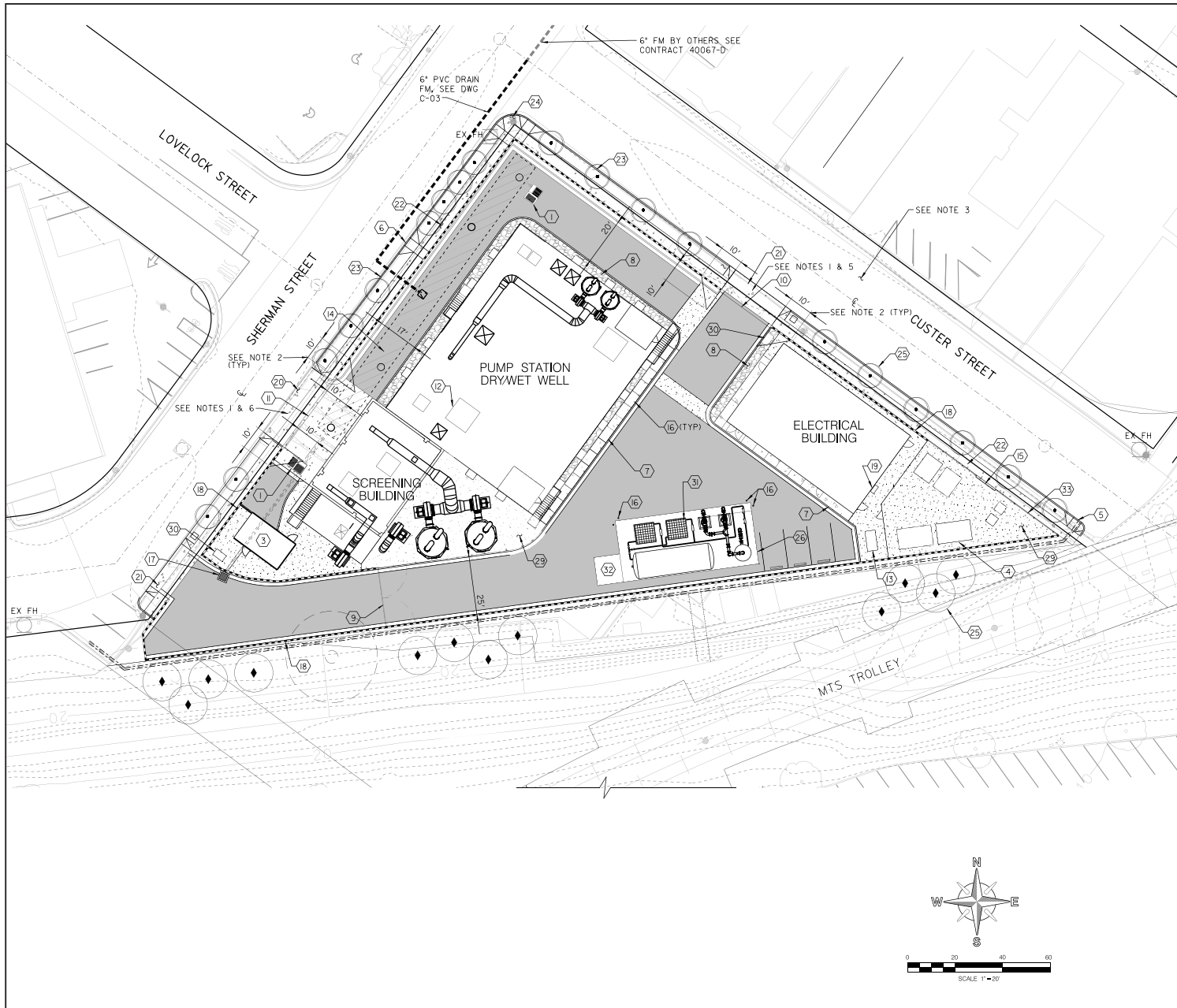

- KEYNOTES
- ① MODULAR WETLAND SYSTEM, PER MW-02, DWG C-24
 - ② NOT USED
 - ③ MAINTENANCE BUILDING, PER DWG C-23
 - ④ SDG&E EQUIPMENT, SEE DWG E-06
 - ⑤ CURB RAMP, PER SDDSD SDG-138
 - ⑥ TYPE B CURB RAMP, PER SDDSD SDG-133
 - ⑦ 4'-0" WIDE CONCRETE WALKWAY PER SDDSD SDG-155 (TYP)
 - ⑧ 3/4" CRUSHED ROCK
 - ⑨ 25' DOUBLE LEAF WROUGHT IRON ENTRANCE ONLY ACCESS GATE, SEE DETAIL I, DWG C-08
 - ⑩ 25' WIDE 8' HIGH ROLLING GATE, SEE DETAIL 2, DWG C-08
 - ⑪ 35' WIDE, 8' HIGH WROUGHT IRON ROLLING GATE, SEE DETAIL 2, DWG C-08
 - ⑫ 6'X6' DOUBLE LEAF EQUIPMENT HATCH (TYP OF 2)
 - ⑬ ELECTRICAL BLDG CONDENSING UNIT, SEE H DWGS
 - ⑭ HYDROMODIFICATION TANK, PER DWG C-06
 - ⑮ 10' WIDE WROUGHT IRON SLIDING GATE
 - ⑯ REMOVABLE PROTECTION POSTS @ 5'-0" OC, PER SDDSD, WM-04 (TYPE "B") (TYP)
 - ⑰ 3'X3' CATCH BASIN, PER SDDSD, D-29
 - ⑱ 8'-0" HIGH MASONRY BLOCK WALL, WITH 1.5 FEET HIGH WROUGHT IRON BARS ON TOP SIMILAR TO SDDSD, C-5, SEE NOTE I
 - ⑲ MOTOR CONTROL ROOM CONDENSING UNIT, SEE H DWGS
 - ⑳ 35' WIDE CONCRETE DRIVEWAY, PER SDDSD, SDG-163
 - ㉑ 25' WIDE CONCRETE DRIVEWAY PER SDDSD, SDG-163
 - ㉒ 5' CONCRETE SIDEWALK (NON-CONTIGUOUS) PER SDDSD, SDG-155
 - ㉓ 6-INCH CURB AND GUTTER PER SDDSD, SDG-151
 - ㉔ DUAL CURB RAMP PER SDDSD, SDG-134
 - ㉕ PROPOSED LANDSCAPING, SEE DWG L-01
 - ㉖ 18" REINFORCED CONCRETE SLAB ON GRADE PER DETAIL 4, DWG S-5
 - ㉗ NOT USED
 - ㉘ NOT USED
 - ㉙ 6" PCC SURFACE PER SDDSD, G-18
 - ㉚ BACKFLOW PREVENTER, PER DWG C-03
 - ㉛ HIGH PURITY OXYGENATION FACILITY, SEE DWG C-25
 - ㉜ 12'-0" X 12'-0" LIQUID OXYGEN FILL CONCRETE APRON
 - ㉝ 9'-6" H WROUGHT IRON FENCE PER DETAIL XX, DWG X-X

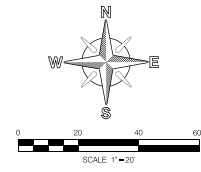

SOURCE: KEH & Associates 2018

DUDEK

Pure Water San Diego Program North City Project EIR/EIS

FIGURE 3-5
Morena Pump Station Conceptual Site Layout

INTENTIONALLY LEFT BLANK

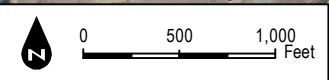

- Morena Pumpstation
- Trenchless Segments of Alignment
- Morena Wastewater Forcemain and Brine/Centrates Line
- Morena Pump Station - Overflow Pipe
- Morena Pump Station - Influent Diversion Sewers
- Air/Vacuum Release Valves

SOURCE: City San Diego, 2016, 2017, 2018; SanGIS 2017; SANDAG

FIGURE 3-6A

Morena Wastewater Forcemain and Brine/Centrates Line Alignment



Pure Water San Diego Program North City EIR/EIS

INTENTIONALLY LEFT BLANK

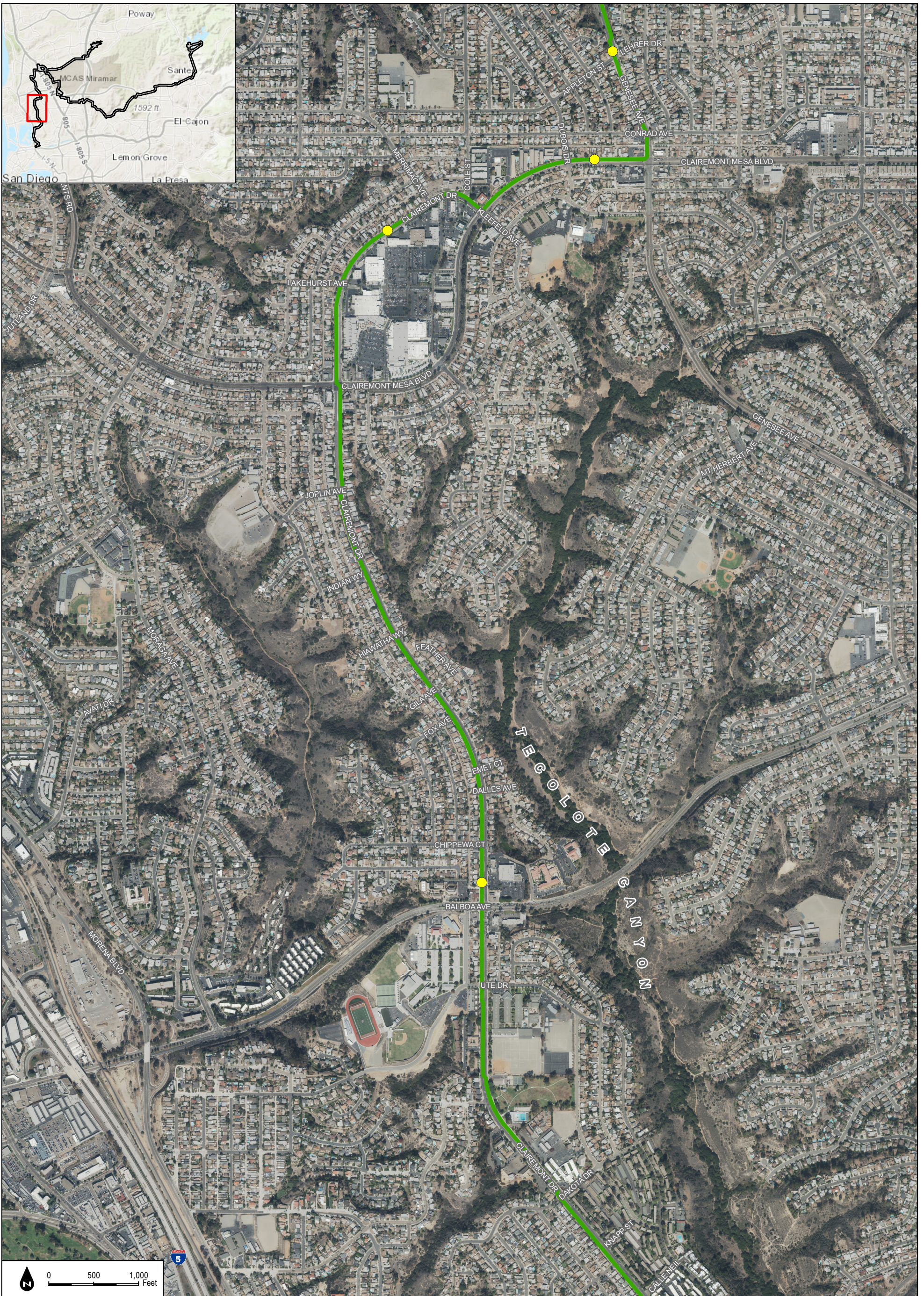

- Morena Wastewater Forcemain and Brine/Centrates Line
- Air/Vacuum Release Valves

SOURCE: City San Diego, 2016, 2017, 2018; SanGIS 2017; SANDAG



Pure Water San Diego Program North City EIR/EIS

FIGURE 3-6B
Morena Wastewater Forcemain and Brine/Centrates Line Alignment

INTENTIONALLY LEFT BLANK

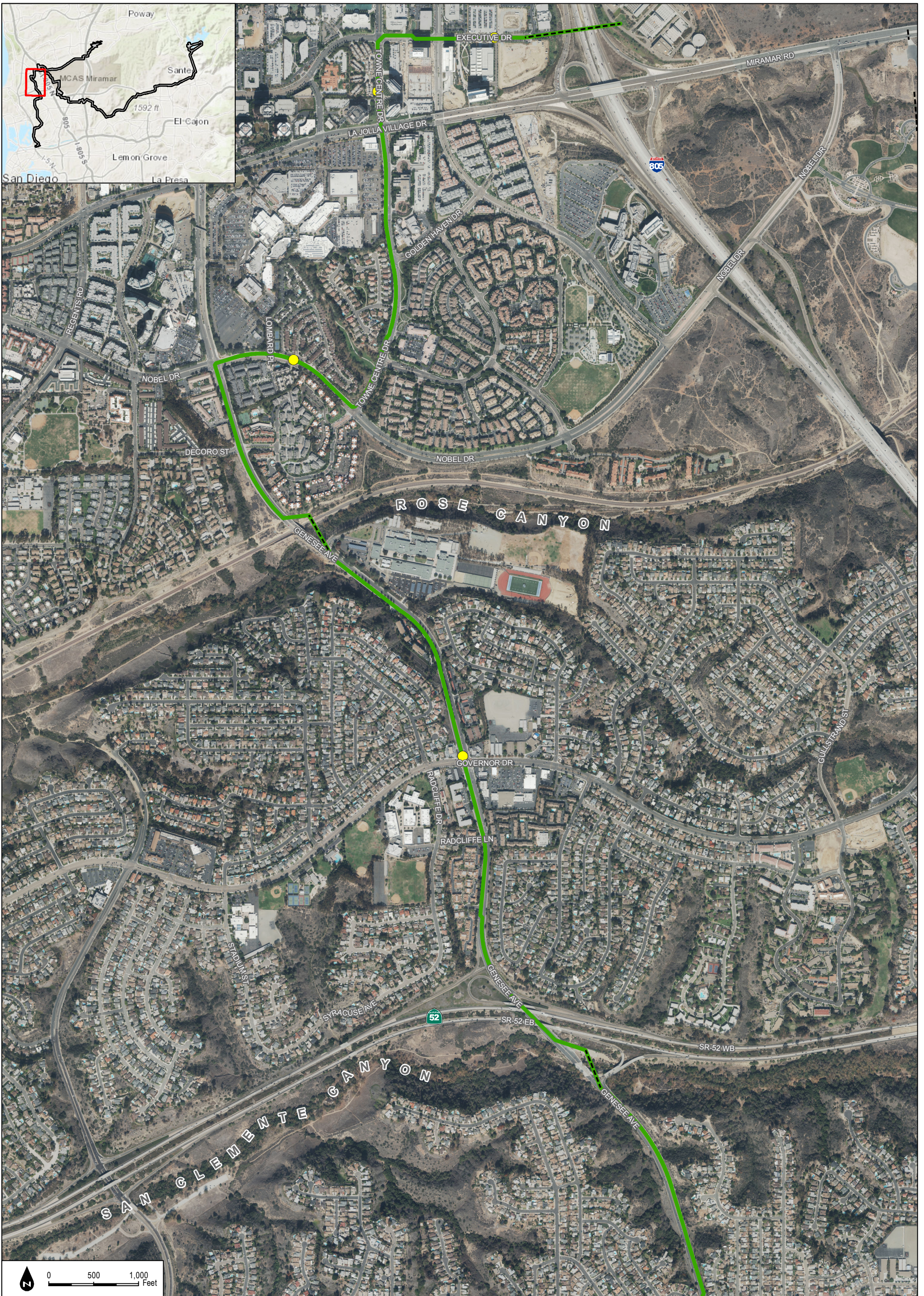

- Trenchless Segments of Alignment
- Morena Wastewater Forcemain and Brine/Centrates Line
- Air/Vacuum Release Valves

SOURCE: City San Diego, 2016, 2017, 2018; SanGIS 2017; SANDAG

DUDEK

Pure Water San Diego Program North City EIR/EIS

FIGURE 3-6C
Morena Wastewater Forcemain and Brine/Centrates Line Alignment

INTENTIONALLY LEFT BLANK

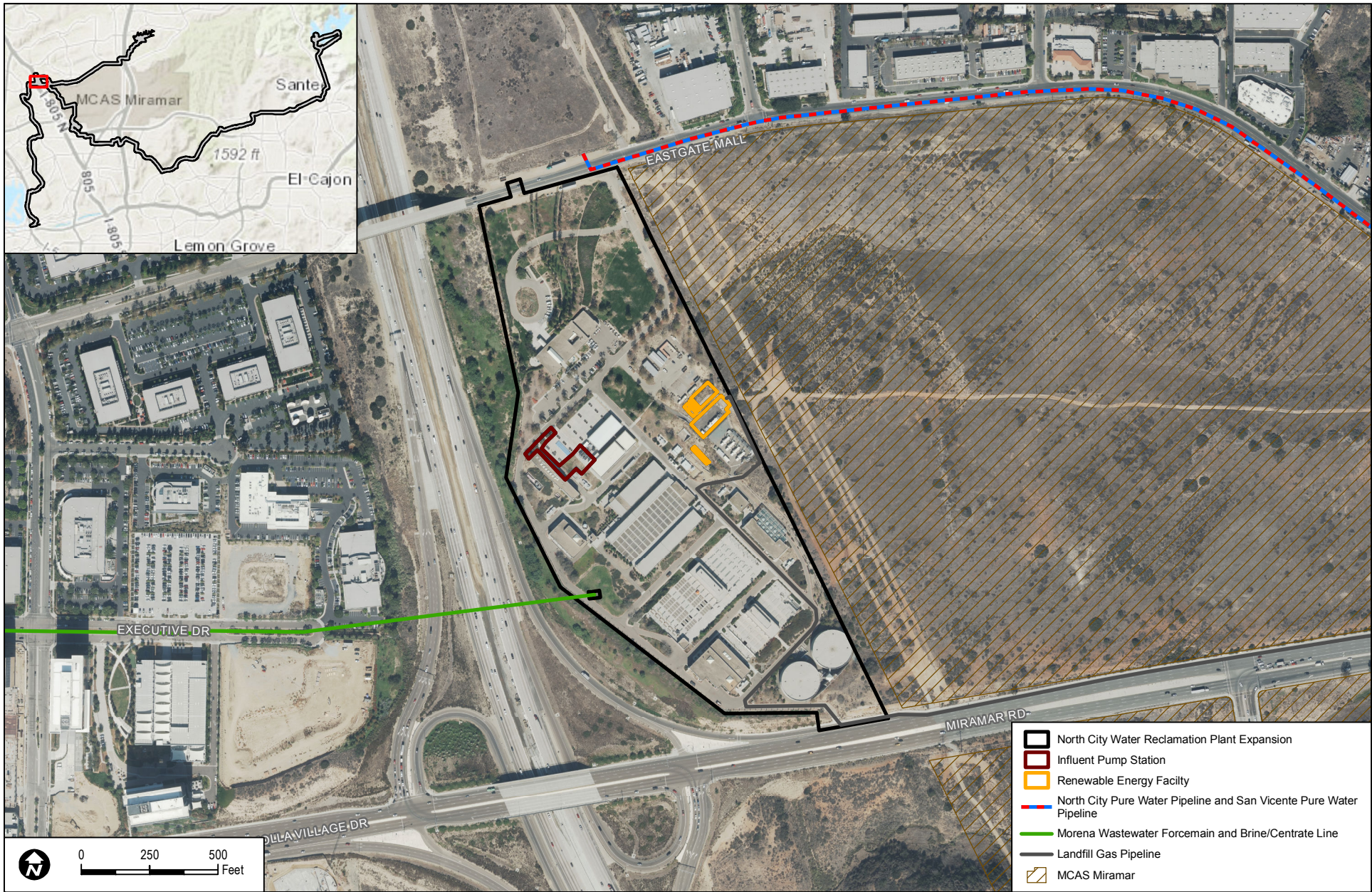

SOURCE: City of San Diego 2016, 2017; SANDAG

DUDEK

Pure Water San Diego Program North City Project EIR/EIS

FIGURE 3-7

North City Water Reclamation Plant Expansion Site

INTENTIONALLY LEFT BLANK

North City Water Reclamation Plant Expansion

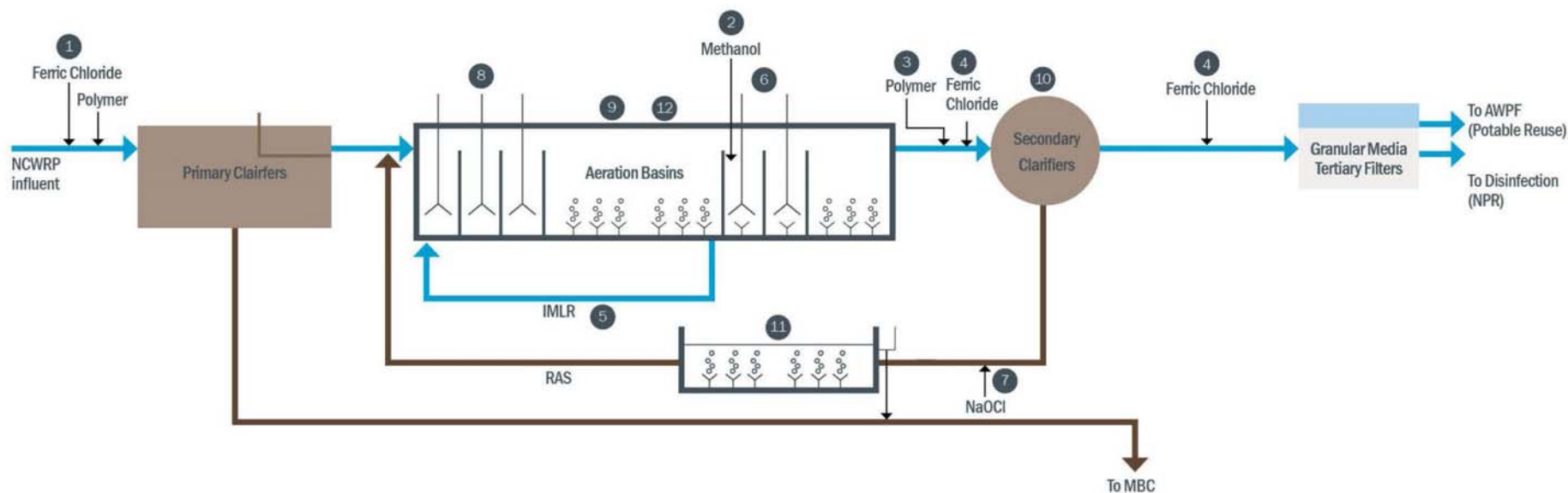

- | | | |
|---|---|--|
| <ul style="list-style-type: none"> 1 Chemically enhanced primary treatment (CEPT) to reduce organic loading to the secondary process 2 Methanol addition to improve denitrification 3 Polymer addition to reduce secondary effluent turbidity 4 Ferric chloride addition to remove phosphorus in tertiary filters | <ul style="list-style-type: none"> 5 Install pumps with new pumps equipped with VFDs to provide versatility for denitrification 6 Convert to 4- stage Bardenpho with swing zone for additional denitrification 7 Sodium hypochlorite addition to mitigate filamentous bulking 8 Replace submerged mixers with vertical shaft mixers to reduce maintenance time and cost | <ul style="list-style-type: none"> 9 Install dissolved oxygen (DO) control to save energy 10 New circular flocculator secondary clarifiers with suction sludge removal 11 Install classifying selector for biological foam elimination 12 Install new diffusers to satisfy oxygen requirements |
|---|---|--|

INTENTIONALLY LEFT BLANK



SOURCE: ch2m 2017

DUDEK

Pure Water San Diego Program North City Project EIR/EIS

FIGURE 3-9
North City Water Reclamation Plant Expansion Conceptual Site Plan

INTENTIONALLY LEFT BLANK



Above: NCWRP Site Plan and Location of NCAWPF IPS

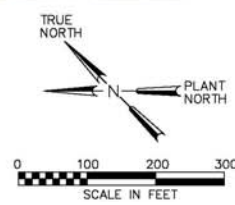

- FACILITIES LEGEND**
- ① INFLUENT PUMP STATION
 - ② HEADWORKS
 - ③ PRIMARY SEDIMENTATION TANKS
 - ④ INTERMEDIATE PUMP STATION
 - ⑤ FLOW EQUALIZATION
 - ⑥ AERATION BASINS
 - ⑦ SECONDARY CLARIFIERS
 - ⑧ SECONDARY EFFLUENT SPLITTER BOX
 - ⑨ COAGULATION AND METERING
 - ⑩ TERTIARY FILTERS
 - ⑪ WASTE BACKWASH TANK
 - ⑫ CHLORINE CONTACT TANKS
 - ⑬ EFFLUENT DROP STRUCTURE
 - ⑭ EFFLUENT PUMP STATION
 - ⑮ SLUDGE PUMP STATION
 - ⑯ OPERATIONS BUILDING
 - ⑰ CHEMICAL BUILDING
 - ⑱ ELECTRICAL SUBSTATIONS
 - ⑲ ELECTRICAL MAIN PLANT SWITCHGEAR
 - ⑳ ELECTRICAL SUBSTATION (NIC)

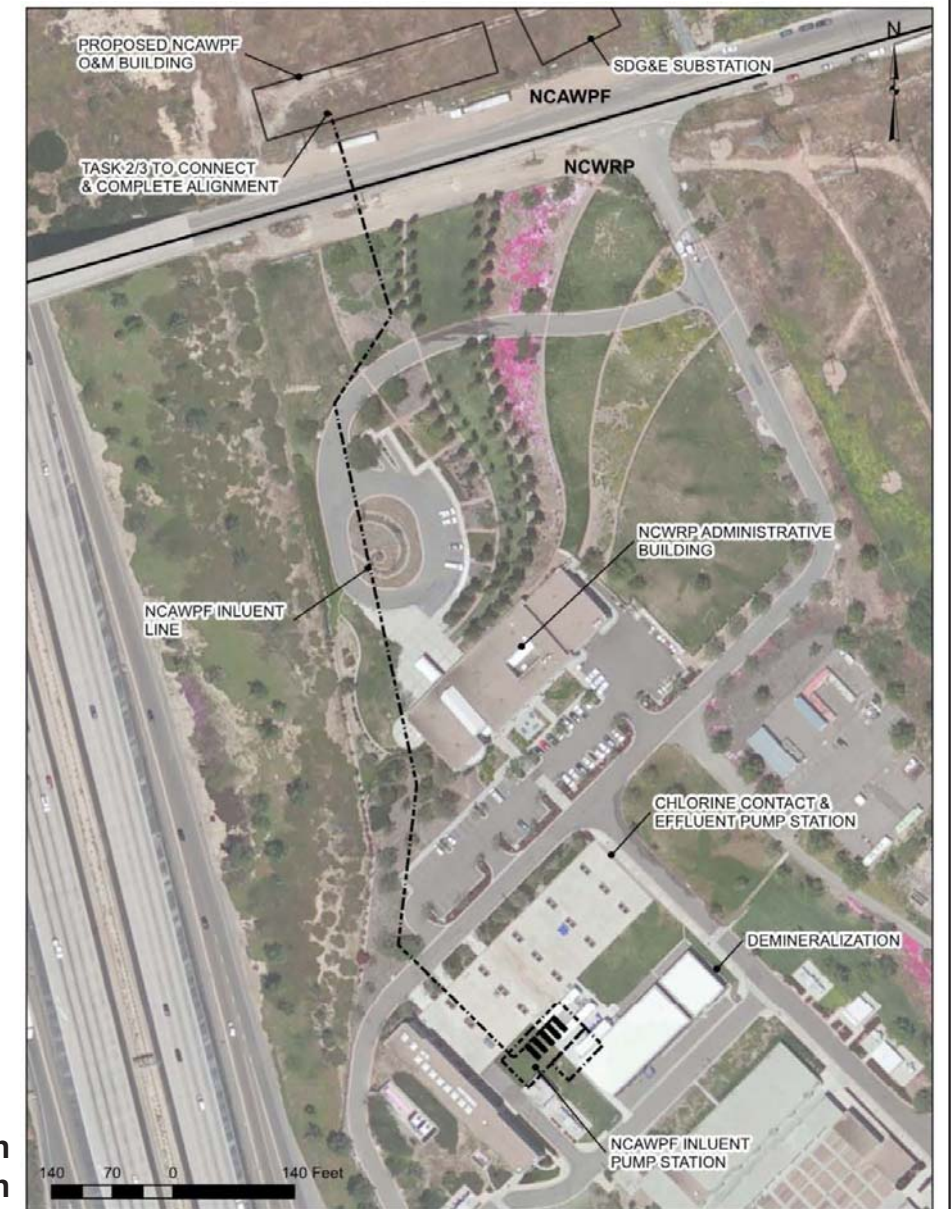

Right: NCAWPF Inflow Pump Station and Pipeline Location

INTENTIONALLY LEFT BLANK



SOURCE: City of San Diego 2016, 2017; SANDAG

DUDEK

Pure Water San Diego Program North City Project EIR/EIS

FIGURE 3-11
North City Pure Water Facility Site

INTENTIONALLY LEFT BLANK

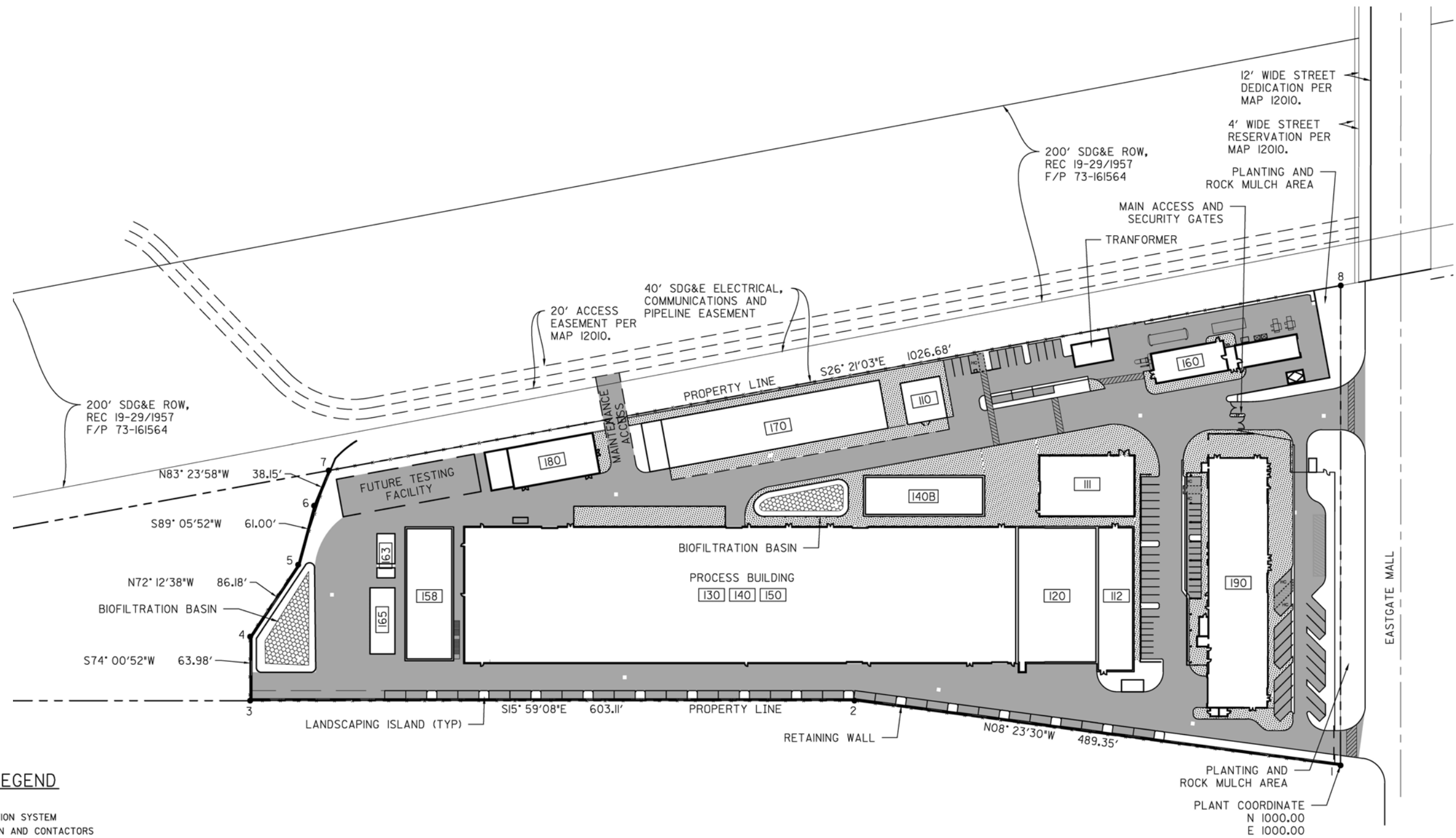

FACILITIES LEGEND

- 110 LOX FACILITY
- 111 OZONE GENERATION SYSTEM
- 112 OZONE INJECTION AND CONTACTORS
- 120 BAC SYSTEM
- 130 MEMBRANE FILTRATION SYSTEM
- 140 REVERSE OSMOSIS SYSTEM
- 140B REVERSE OSMOSIS FEED TANK
- 150 ULTRAVIOLET SYSTEM
- 158 PRODUCT WATER TANK
- 160 NORTH CITY PURE WATER PUMP STATION
- 163 CARBON DIOXIDE SYSTEM
- 165 LIME SYSTEM
- 170 CHEMICAL SYSTEMS
- 180 MAIN ELECTRICAL BUILDING
- 190 OPERATIONS AND MAINTENANCE BUILDING

LEGEND

- PROPERTY LINE
- ASPHALT
- ▨ CONCRETE
- ▩ HANDICAP/PEDESTRIAN WALKWAY

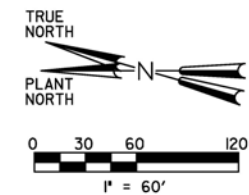

INTENTIONALLY LEFT BLANK

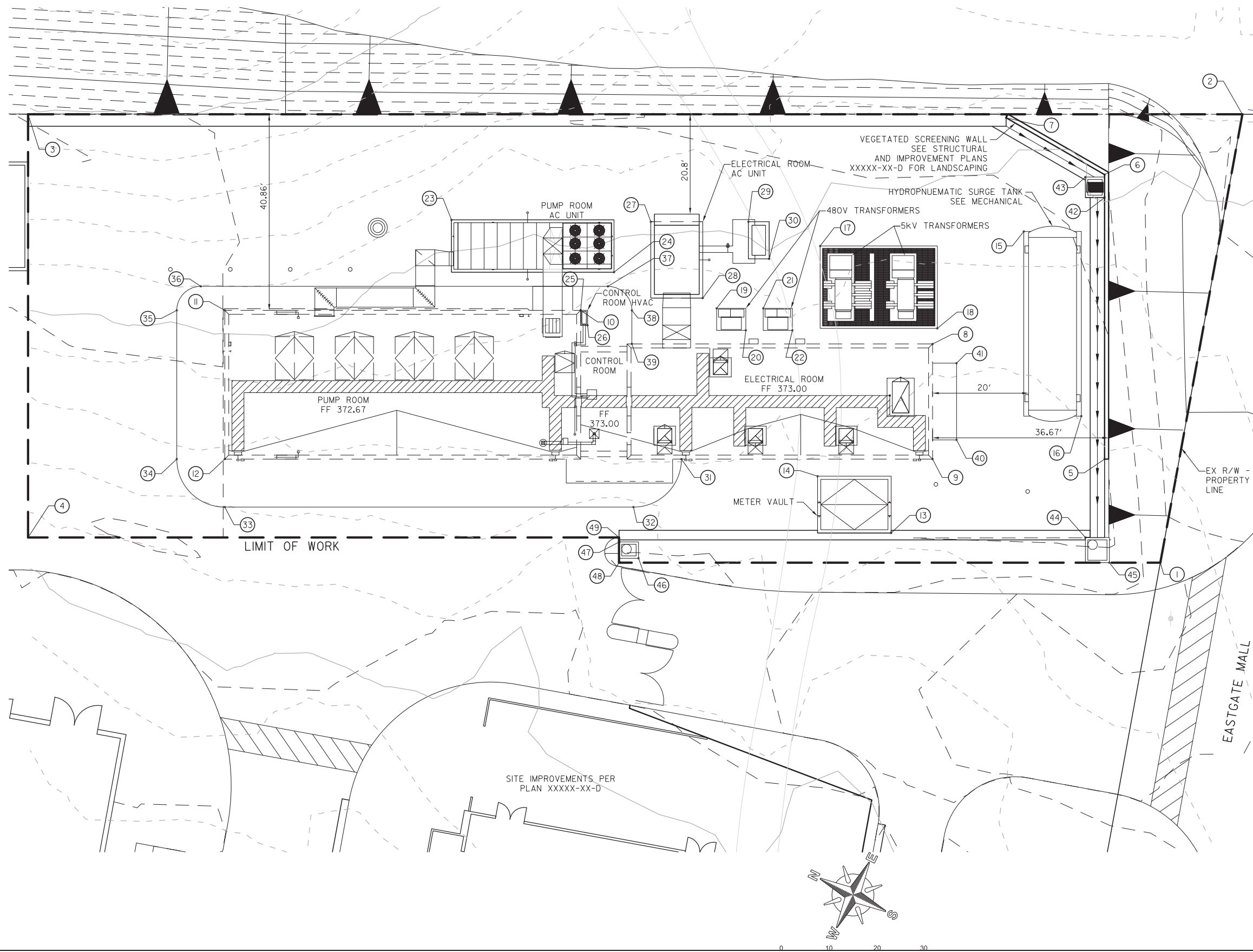

SOURCE: HDR 2017; North City Pure Water Facility 60% Engineering Design Report

DUDEK

Pure Water San Diego Program North City Project EIR/EIS

FIGURE 3-13
North City Pump Station Conceptual Site Layout

INTENTIONALLY LEFT BLANK

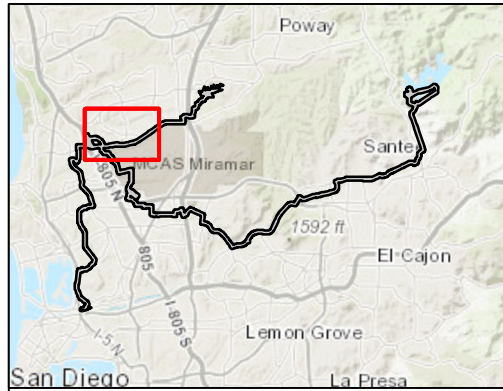

- North City Pure Water Pipeline
- - - Trenchless Segments of Alignment
- MCAS Miramar

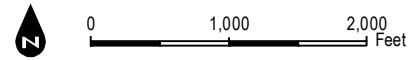

SOURCE: City San Diego, 2017, 2018; SanGIS 2016; SANDAG 2016

DUDEK

Pure Water San Diego Program North City Project EIR/EIS

FIGURE 3-14A
North City Pure Water Pipeline Alignment

INTENTIONALLY LEFT BLANK

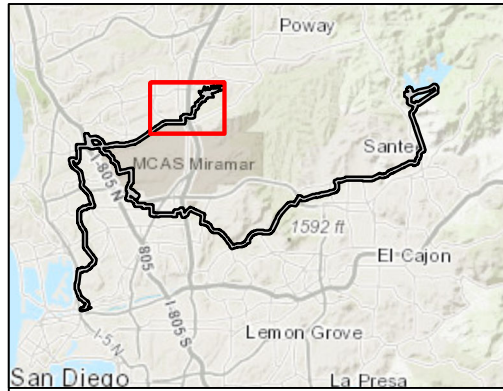

- North City Pure Water Pipeline
- - - North City Pure Water Pipeline - Subaqueous Pipeline
- - - Trenchless Segments of Alignment
- MCAS Miramar

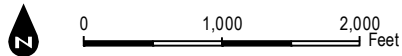
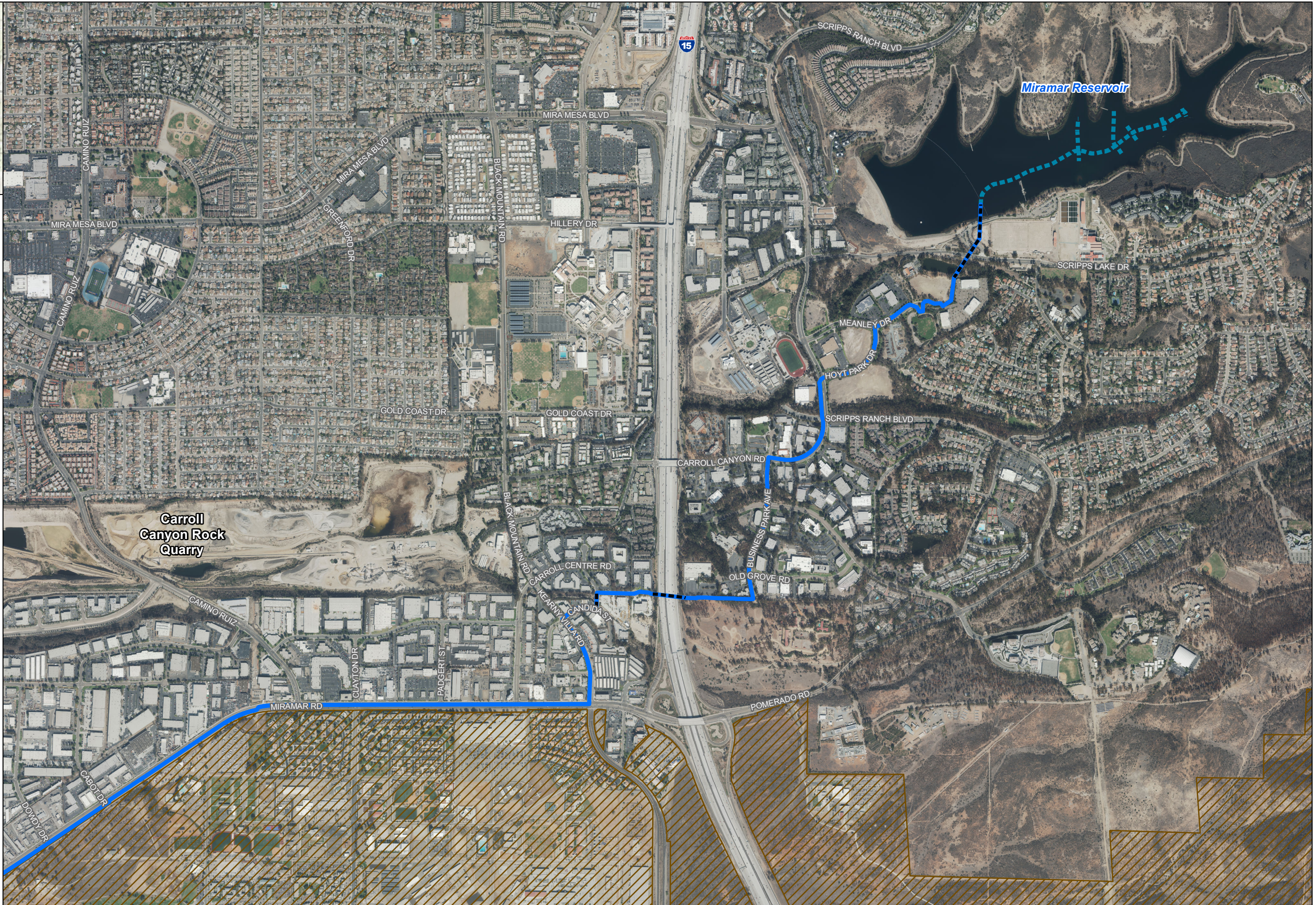

SOURCE: City San Diego, 2017, 2018; SanGIS 2016; SANDAG 2016

FIGURE 3-14B
North City Pure Water Pipeline Alignment

INTENTIONALLY LEFT BLANK

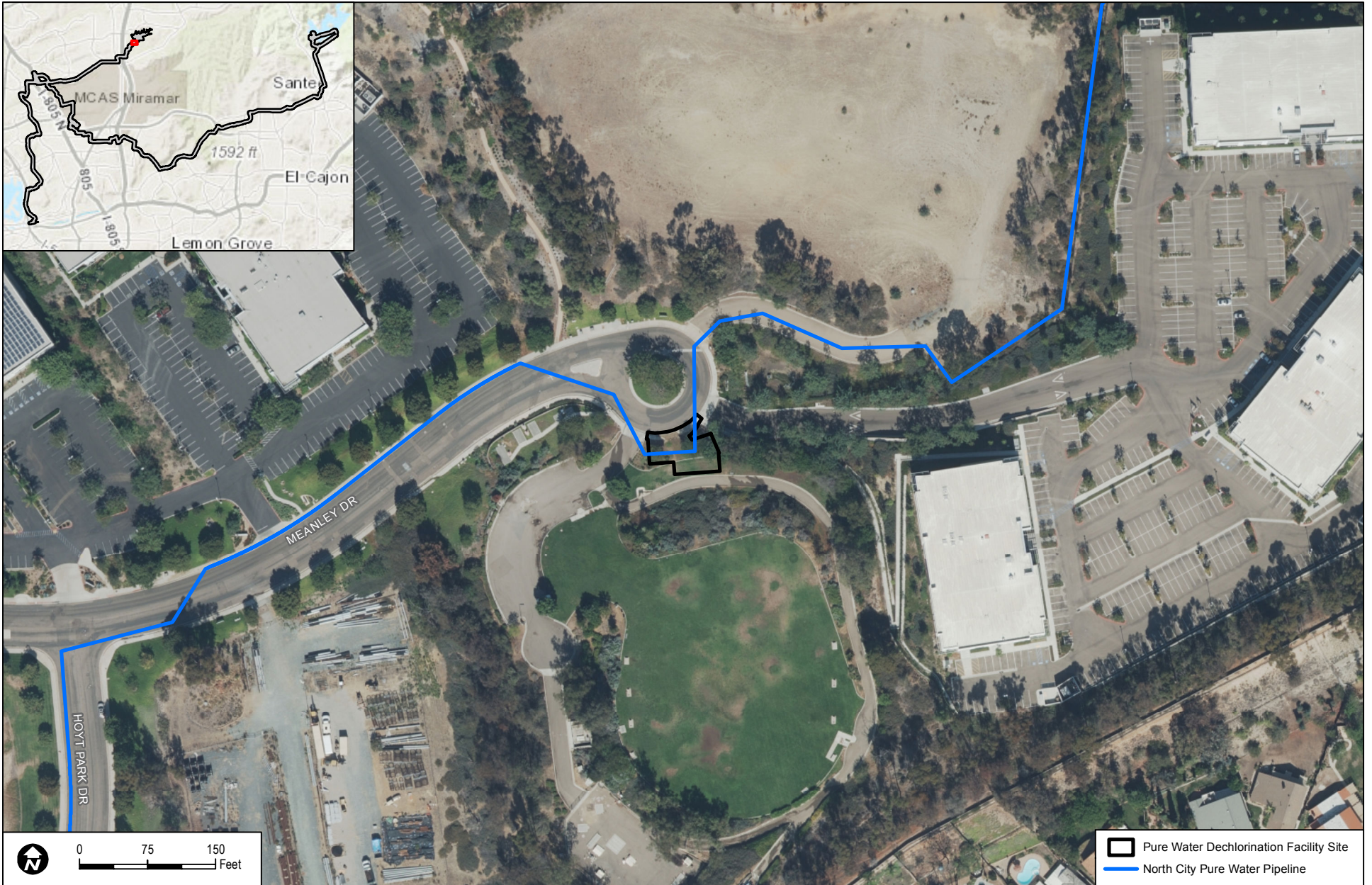

SOURCE: City of San Diego 2016, 2017; SANDAG

DUDEK

Pure Water San Diego Program North City Project EIR/EIS

FIGURE 3-15

Pure Water Dechlorination Facility Site

INTENTIONALLY LEFT BLANK

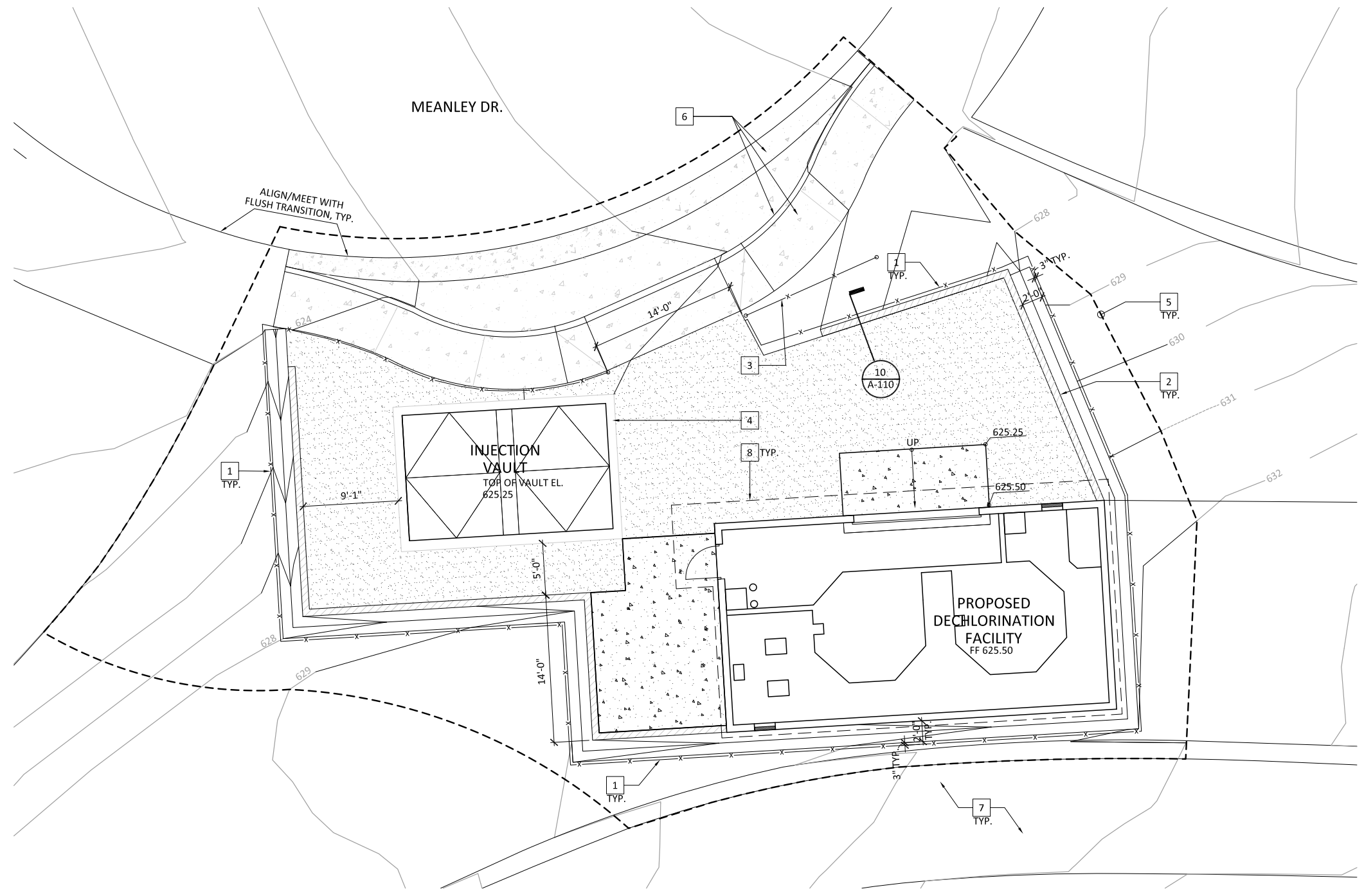

GENERAL NOTES

- 1 ALL ITEMS REFERENCED ARE NEW, UNLESS NOTED OTHERWISE.
- 2 REFER TO CIVIL, STRUCTURAL, MECHANICAL, ELECTRICAL, AND LANDSCAPE DRAWINGS FOR MORE INFORMATION.
- 3 REFER TO A-101 AND A-102 FOR ADDITIONAL NOTES AND INFORMATION.
- 4 FOR CITY OF SAN DIEGO USE:
RETAINING WALL TOTAL LENGTH: APPROX. 123.42 FEET
SECURITY FENCE TOTAL LENGTH: APPROX. 236.78 FEET

LEGEND

- REINFORCED CMU WALL PER STRUCTURAL SHEET S-106
- CONCRETE SLAB ON GRADE - REFER TO CIVIL FOR FURTHER INFORMATION
- AC PAVING - 2% MAX SLOPE AWAY FROM BUILDING - REFER TO CIVIL DRAWINGS FOR FURTHER INFORMATION
- STEEL PICKET FENCE

KEY NOTES

- 1 PERIMETER FENCE, REFER TO DETAIL 18/A-110
- 2 REINFORCED CMU RETAINING WALL WITH CAP
- 3 ROLLER ACCESS GATE, REFER TO DETAIL 20/A-110
- 4 UNDERGROUND VAULT PER MECHANICAL
- 5 DASHED LINE INDICATES CIVIL LIMIT OF WORK
- 6 SIDEWALK, CURB AND GUTTER PER CIVIL
- 7 EXISTING ACCESS ROAD ABOVE SITE - REFER TO CIVIL
- 8 LINE OF ROOF ABOVE



SOURCE: HDR 2018; North City Pure Water Facility 100% Engineering Design Report

Pure Water San Diego Program North City Project EIR/EIS

FIGURE 3-16
Pure Water Dechlorination Facility Conceptual Site Layout

INTENTIONALLY LEFT BLANK

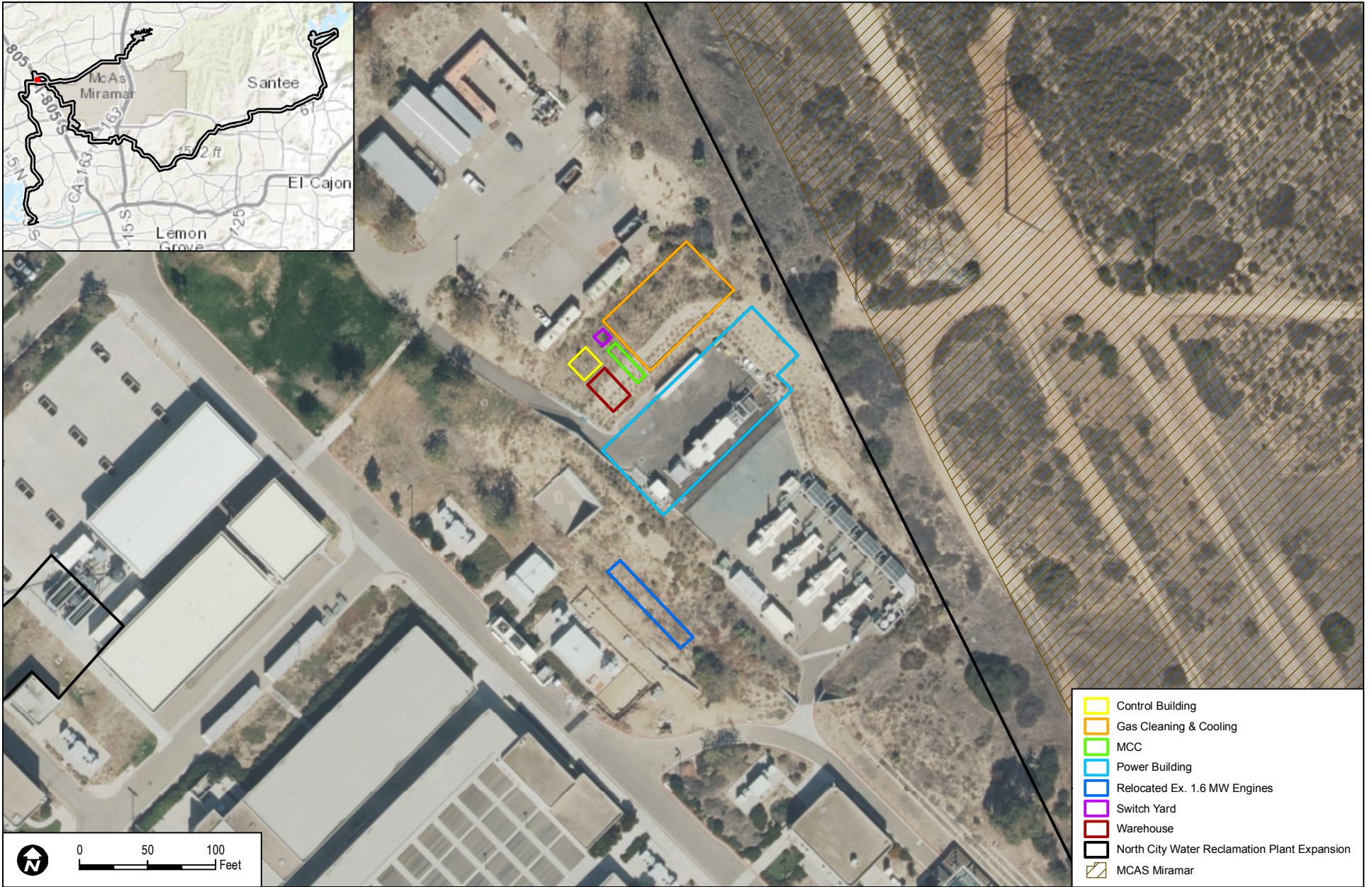

SOURCE: City of San Diego 2016, 2017; SANDAG

DUDEK

Pure Water San Diego Program North City Project EIR/EIS

FIGURE 3-17

North City Renewable Energy Facility Conceptual Site Layout

INTENTIONALLY LEFT BLANK

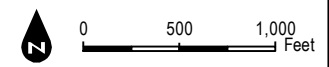
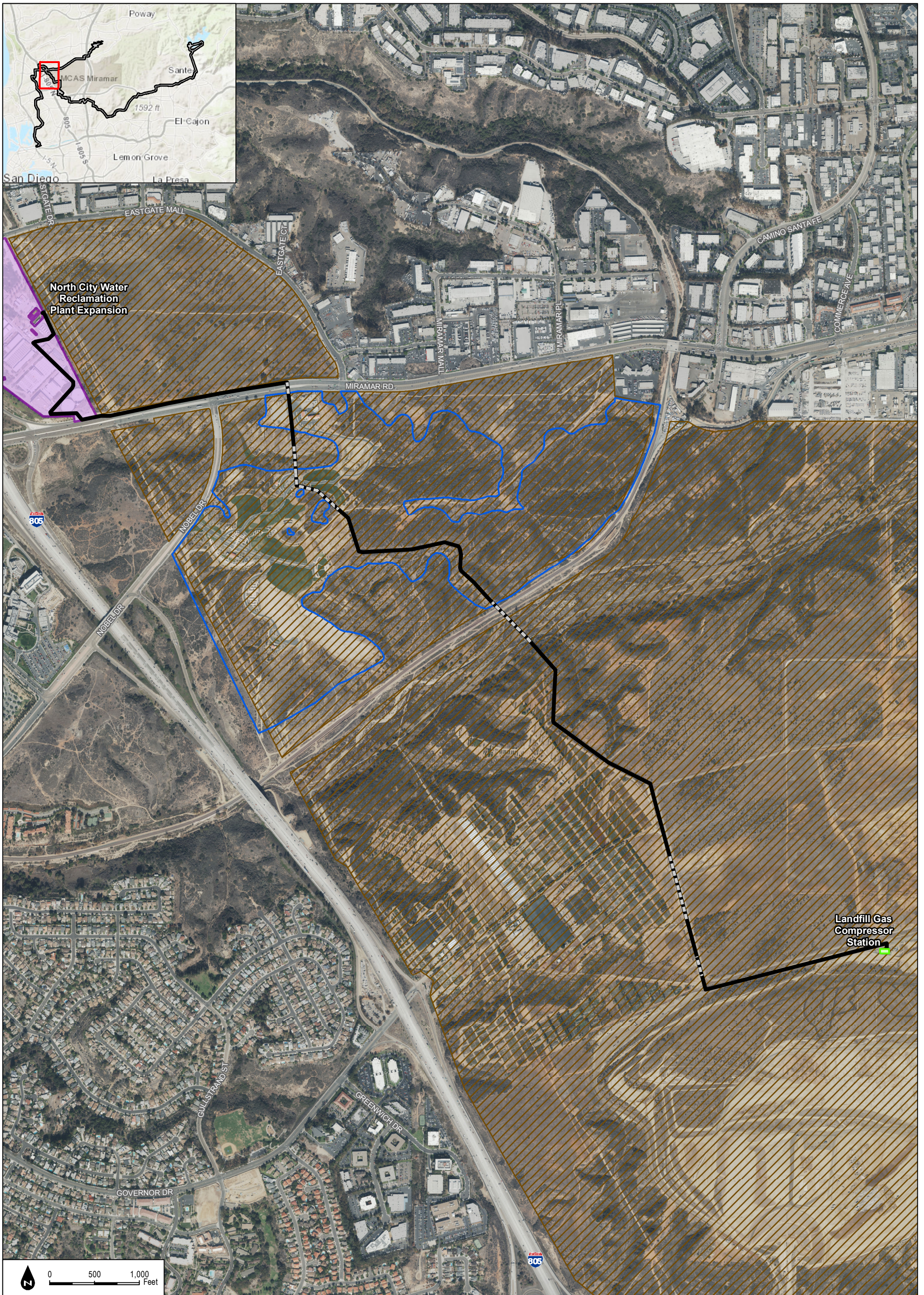

- Trenchless Segments of Alignment
- Landfill Gas Pipeline
- Landfill Gas Compressor Station
- Morena Pumpstation
- VA Cemetery Boundary
- ▨ MCAS Miramar

INTENTIONALLY LEFT BLANK



SOURCE: City of San Diego 2016, 2017; SANDAG

DUDEK

Pure Water San Diego Program North City Project EIR/EIS

FIGURE 3-19
Metro Biosolids Center Site

INTENTIONALLY LEFT BLANK

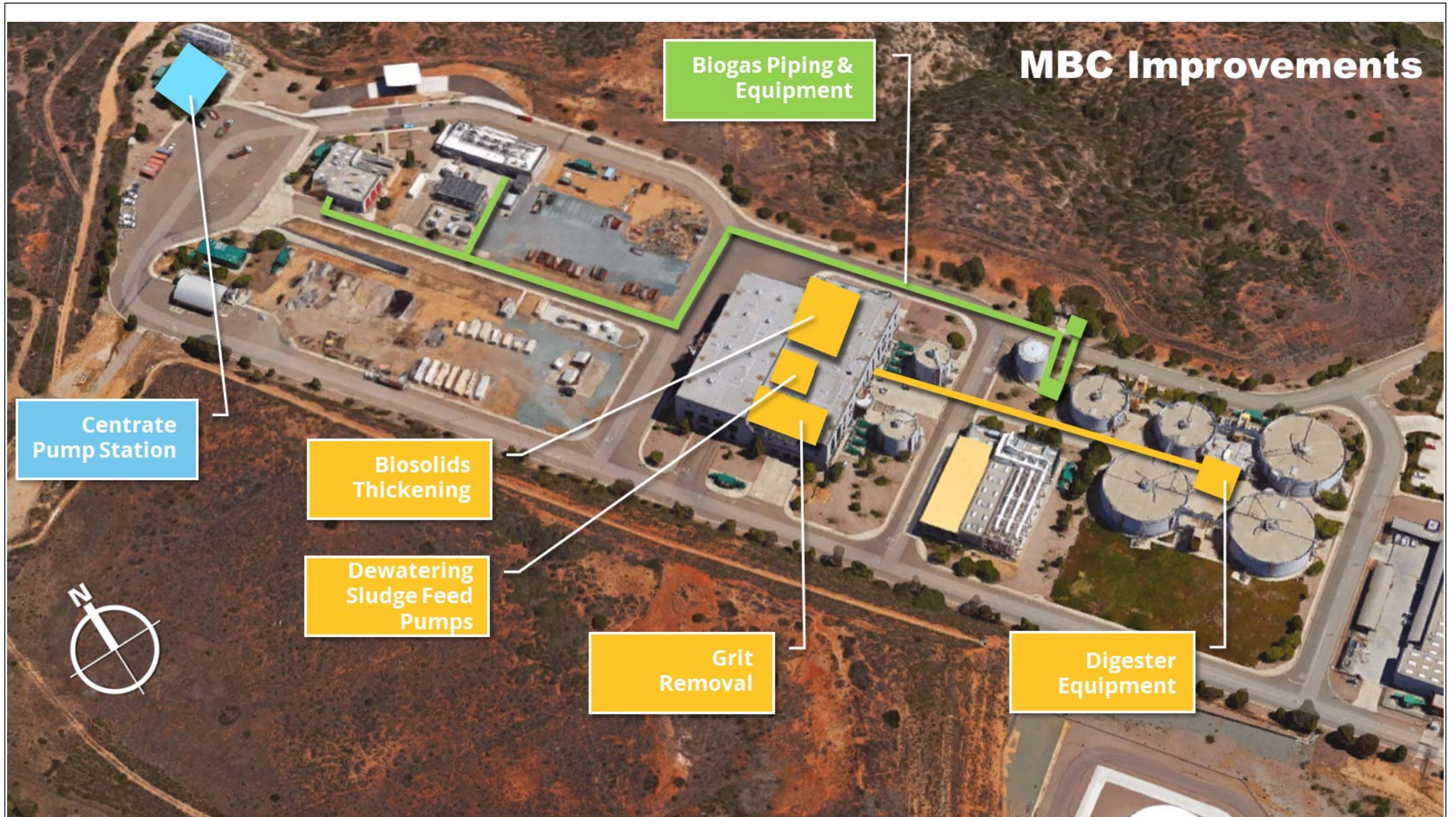

SOURCE: City of San Diego, 2017

FIGURE 3-20
Metro Biosolids Center Improvements Conceptual Site Layout

INTENTIONALLY LEFT BLANK

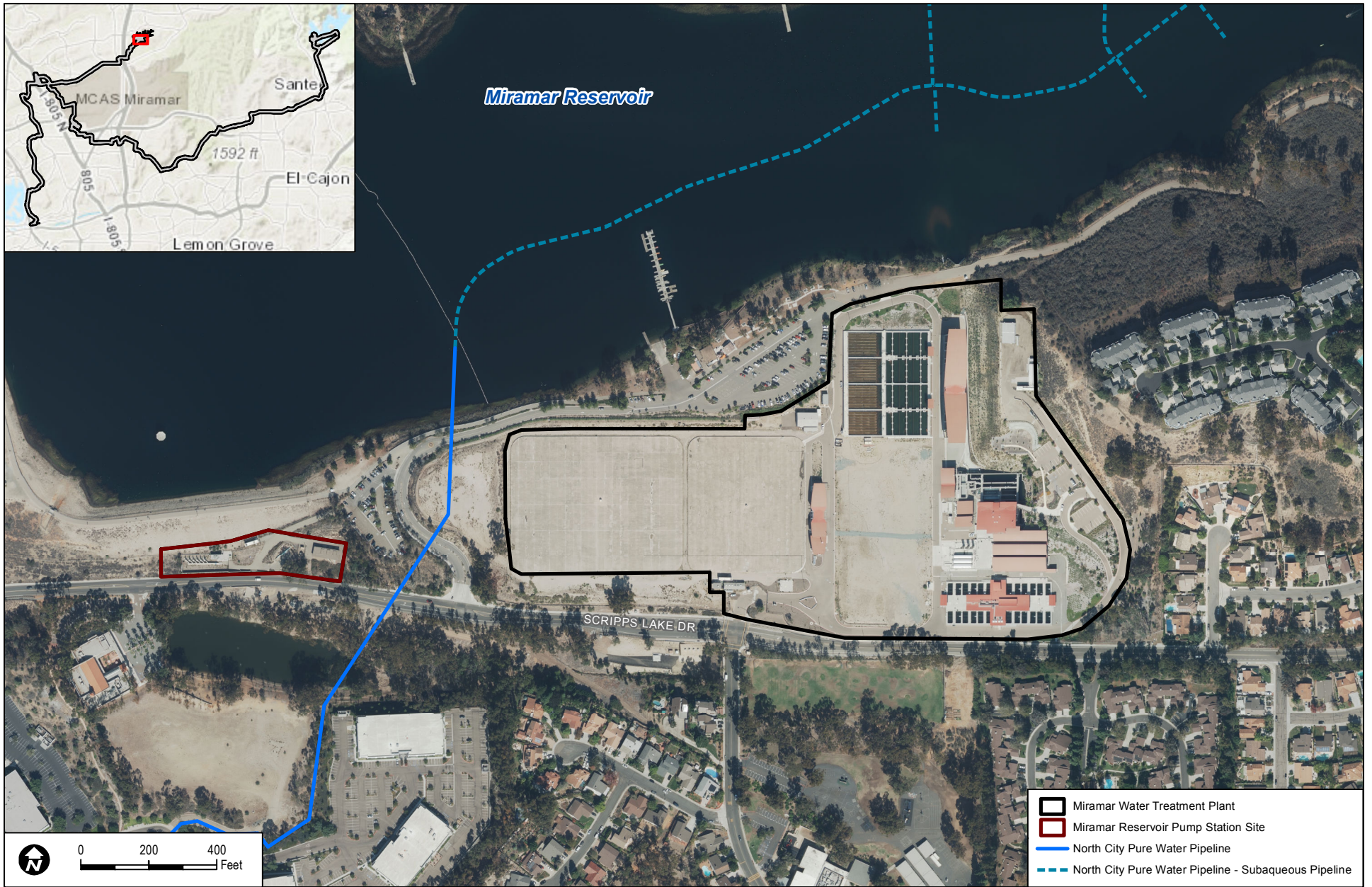

SOURCE: City of San Diego 2016, 2017; SANDAG

FIGURE 3-21

Miramar Water Treatment Plant and Miramar Reservoir Pump Station Site

DUDEK

Pure Water San Diego Program North City Project EIR/EIS

INTENTIONALLY LEFT BLANK

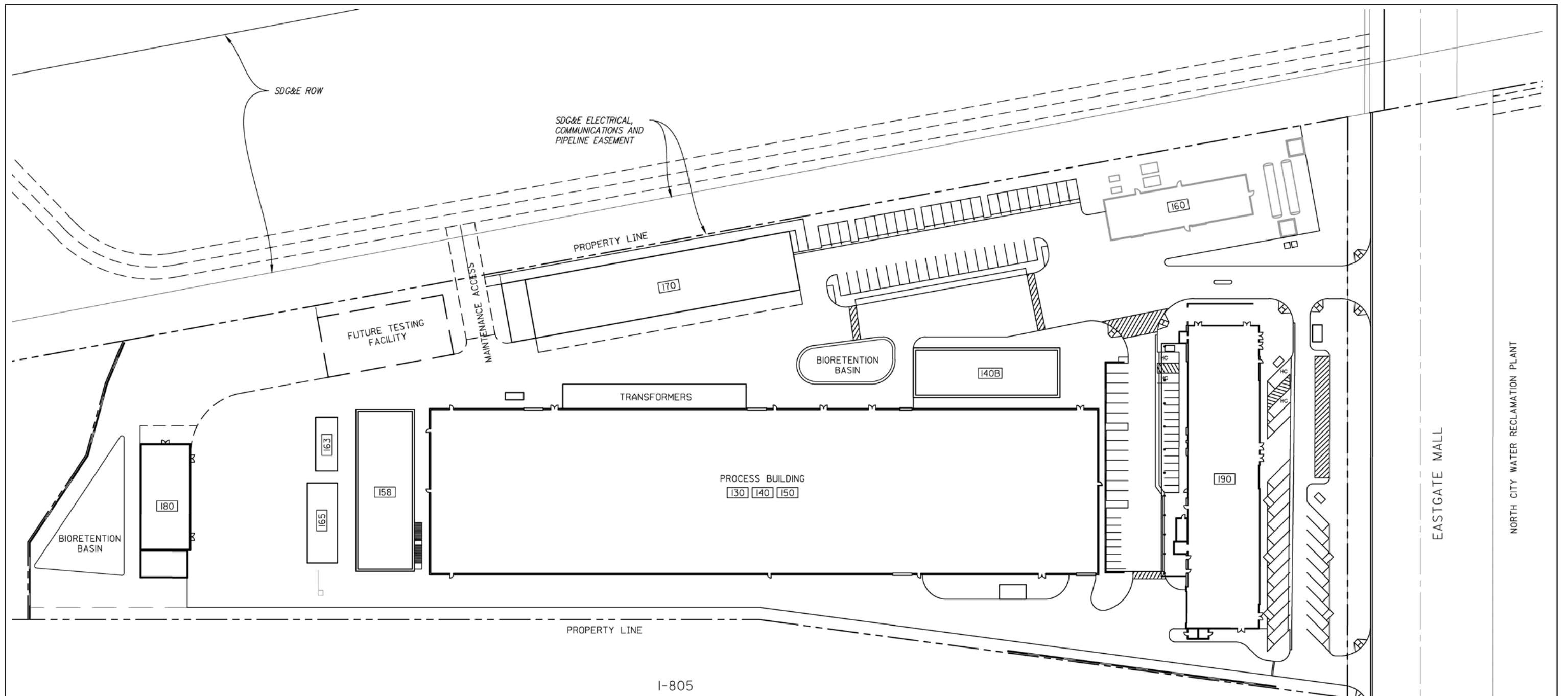

FACILITIES LEGEND

- [130] MEMBRANE FILTRATION SYSTEM
- [140] REVERSE OSMOSIS SYSTEM
- [140B] REVERSE OSMOSIS FEED TANK
- [150] ULTRAVIOLET SYSTEM
- [158] PRODUCT WATER TANK
- [160] PRODUCT WATER PUMP STATION
- [163] CARBON DIOXIDE SYSTEM
- [165] LIME SYSTEM
- [170] CHEMICAL SYSTEMS
- [180] MAIN ELECTRICAL BUILDING
- [190] OPERATIONS AND MAINTENANCE BUILDING

SOURCE: Brown and Caldwell 2016; Trussell Technology Inc., 2016; MWH 2016; Beyaz & Patel 2016



FIGURE 3-22
North City Pure Water Facility-San Vicente Reservoir Conceptual Site Layout

INTENTIONALLY LEFT BLANK



SOURCE: City of San Diego 2016, 2017; SANDAG

DUDEK

Pure Water San Diego Program North City Project EIR/EIS

FIGURE 3-23
Mission Trails Booster Station Site

INTENTIONALLY LEFT BLANK

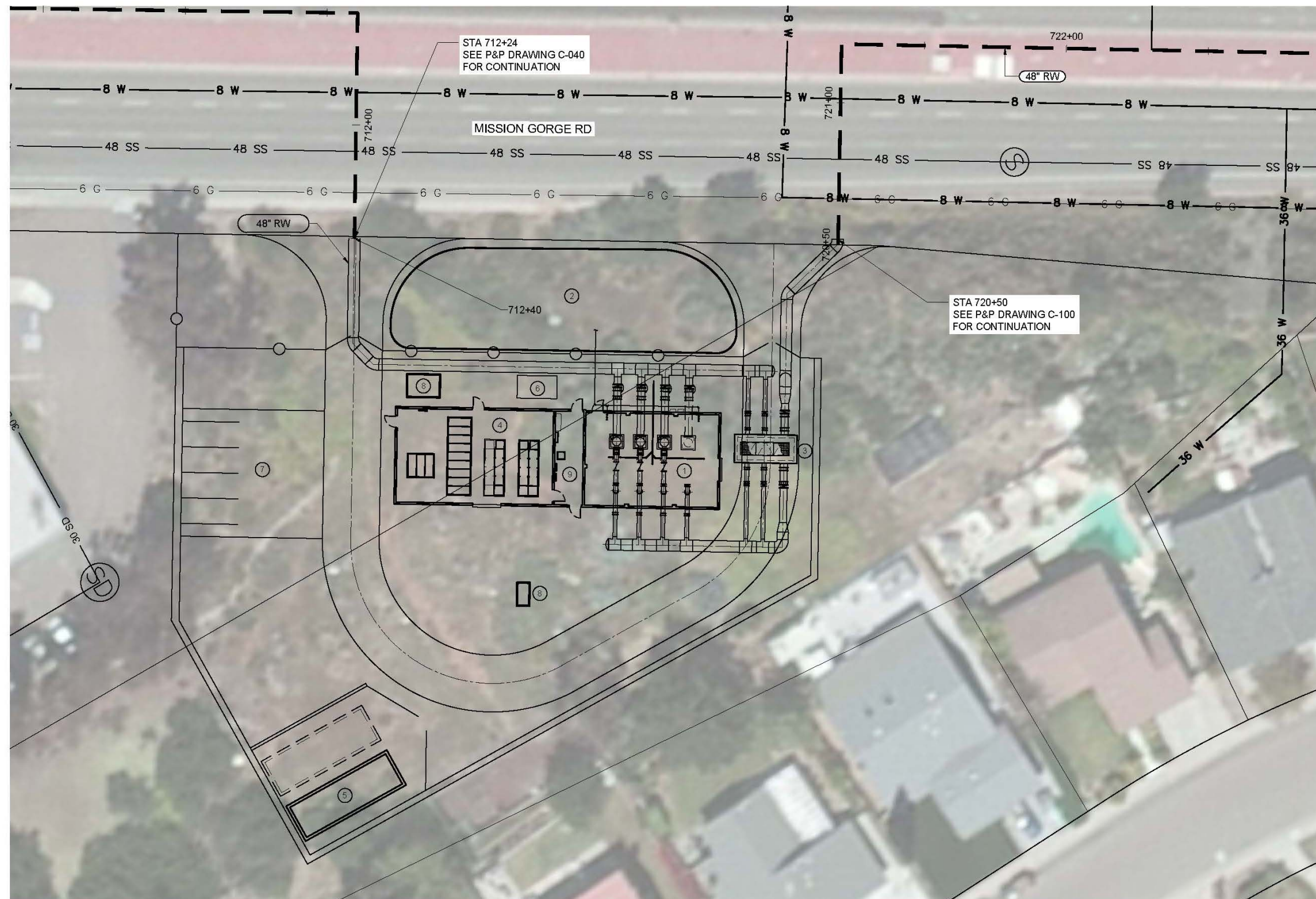

STA 712+24
SEE P&P DRAWING C-040
FOR CONTINUATION

STA 720+50
SEE P&P DRAWING C-100
FOR CONTINUATION

- CONSTRUCTION NOTES:**
- ① PUMP ROOM
 - ② DRAINAGE BASIN
 - ③ PRESSURE RELIEF VALVE AND FLOW METER VAULT
 - ④ ELECTRICAL ROOM
 - ⑤ STANDBY GENERATORS
 - ⑥ HVAC
 - ⑦ PARKING
 - ⑧ TRANSFORMERS
 - ⑨ LOW VOLTAGE I&C ROOM

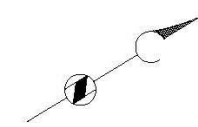
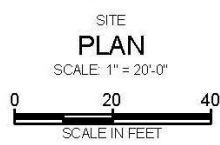

INTENTIONALLY LEFT BLANK

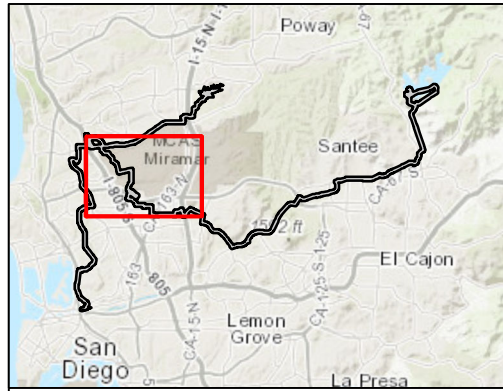

- San Vicente Pure Water Pipeline
- - - Repurposed Existing 36" Pipeline
- MCAS Miramar

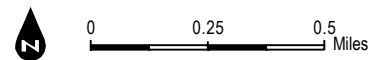
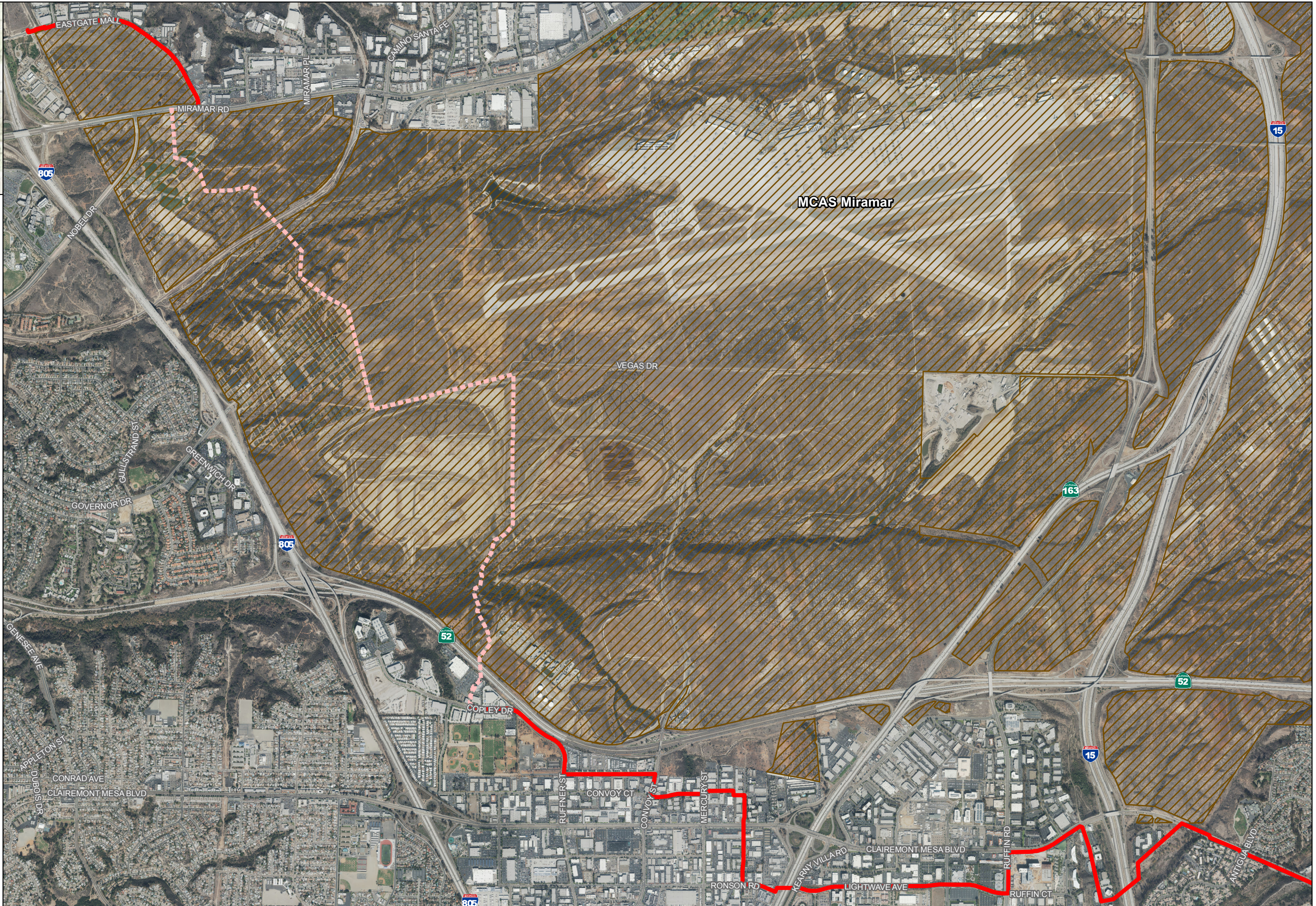

SOURCE: SanGIS 2016; SANDAG 2016

DUDEK

Pure Water San Diego Program North City Project EIR/EIS

FIGURE 3-25A
San Vicente Pure Water Pipeline Alignment

INTENTIONALLY LEFT BLANK

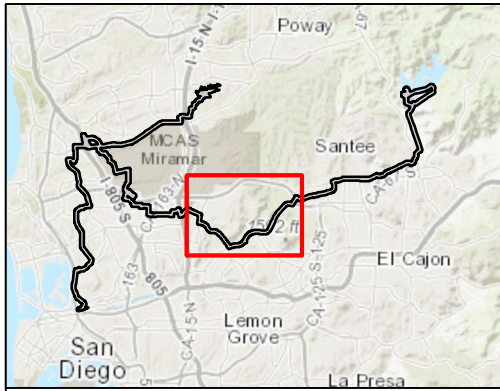

- San Vicente Pure Water Pipeline
- Trenchless Segments of Alignment
- Morena Pumpstation
- MCAS Miramar

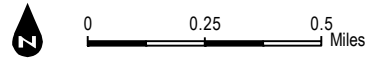

SOURCE: SanGIS 2016; SANDAG 2016

DUDEK

Pure Water San Diego Program North City Project EIR/EIS

FIGURE 3-25B

San Vicente Pure Water Pipeline Alignment

INTENTIONALLY LEFT BLANK

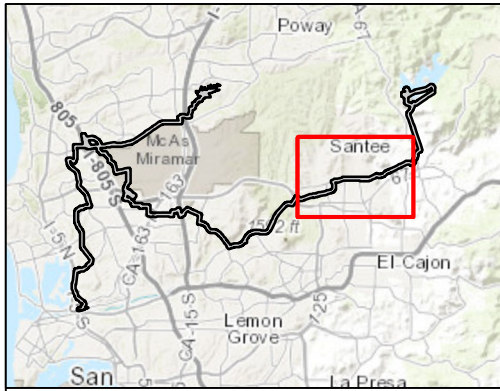

- San Vicente Pure Water Pipeline
- Trenchless Segments of Alignment
- MCAS Miramar

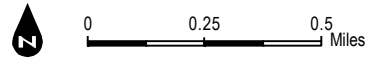

SOURCE: SanGIS 2016; SANDAG 2016

DUDEK

Pure Water San Diego Program North City Project EIR/EIS

FIGURE 3-25C
San Vicente Pure Water Pipeline Alignment

INTENTIONALLY LEFT BLANK

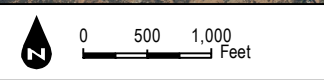
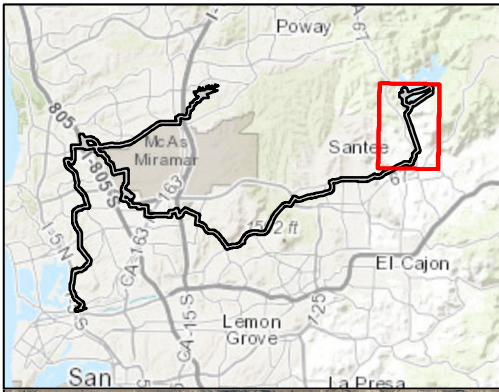

— San Vicente Pure Water Pipeline



SOURCE: City San Diego, 2016, 2016; SanGIS 2017; SANDAG

Pure Water San Diego Program North City EIR/EIS

FIGURE 3-25D
San Vicente Pure Water Pipeline Alignment

INTENTIONALLY LEFT BLANK

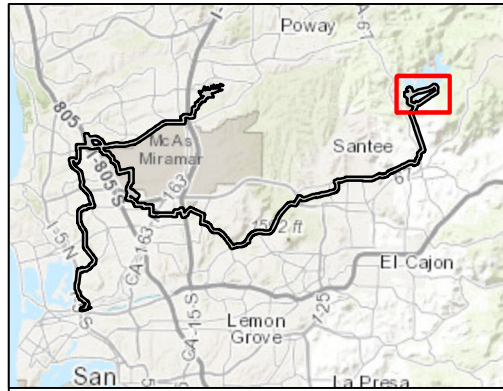

- San Vicente Pure Water Pipeline
- San Vicente Pure Water Pipeline - Marina Alternative Terminus
- San Vicente Pure Water Pipeline - In-Reservoir Alternative Terminus
- - - San Vicente Pure Water Pipeline - Tunnel Alternative Terminus
- - - Trenchless Segments of Alignment

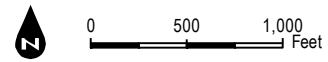
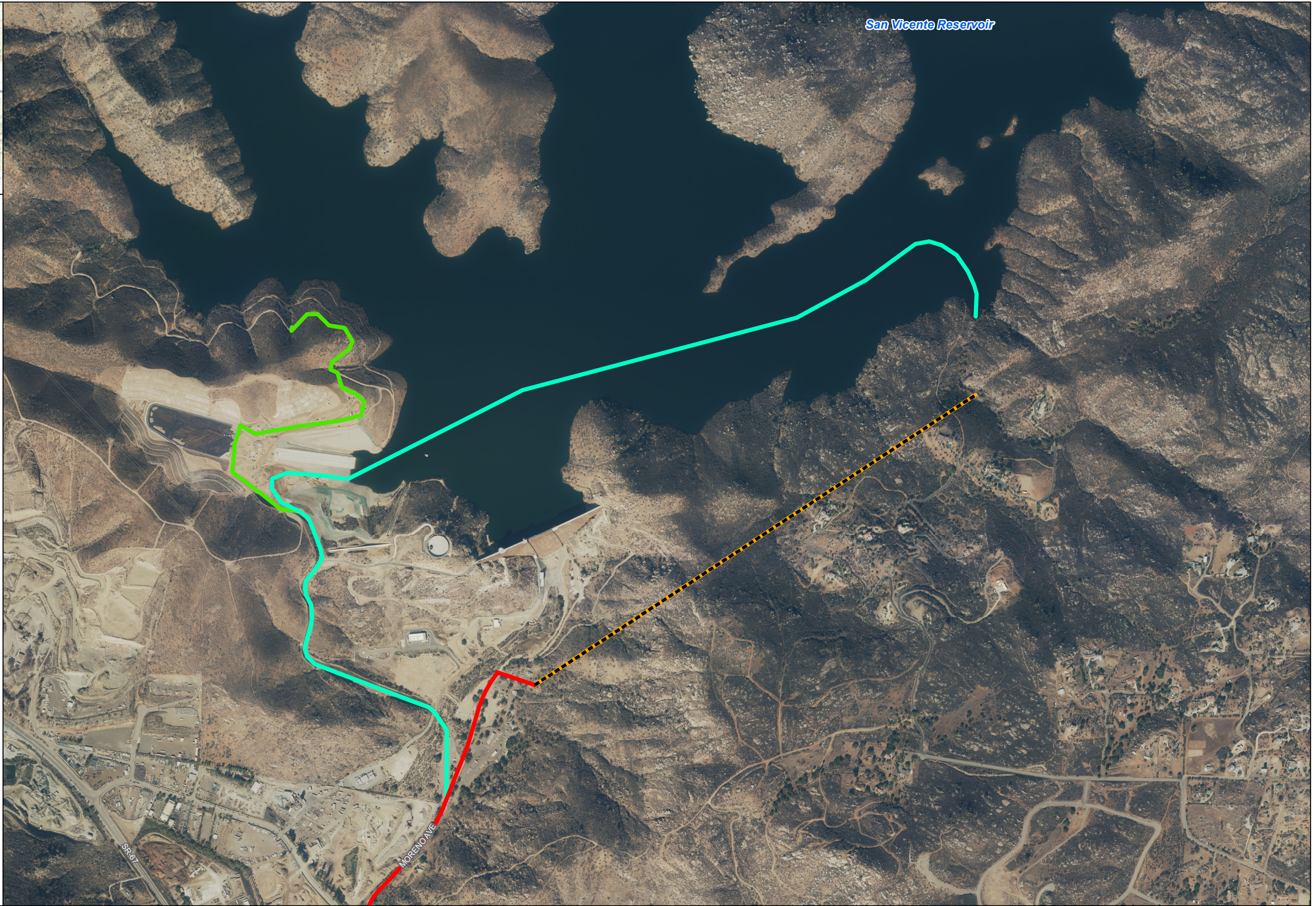

SOURCE: SanGIS 2016; SANDAG 2016

DUDEK

Pure Water San Diego Program North City Project EIR/EIS

FIGURE 3-26

San Vicente Reservoir Inlet Terminus Alternatives

INTENTIONALLY LEFT BLANK

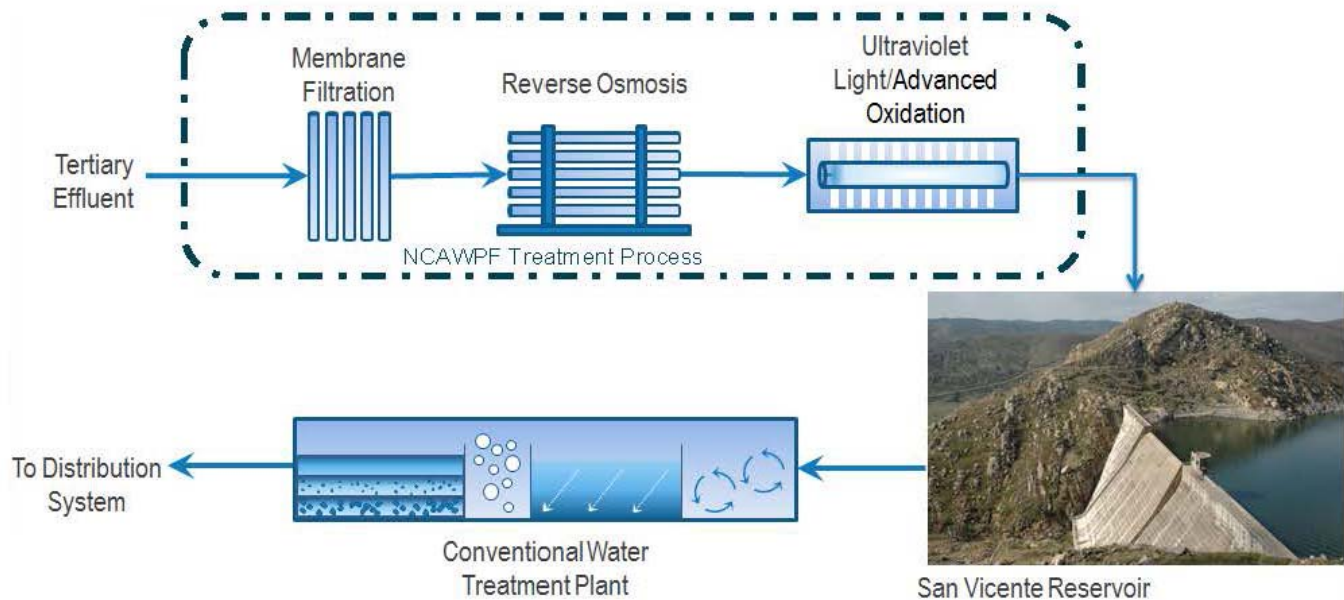

SOURCE: North City Pure Water Facility 30% Engineering Design Report, Jul. 2016

FIGURE 3-27

Pure Water System Overview San Vicente Reservoir Alternative



INTENTIONALLY LEFT BLANK

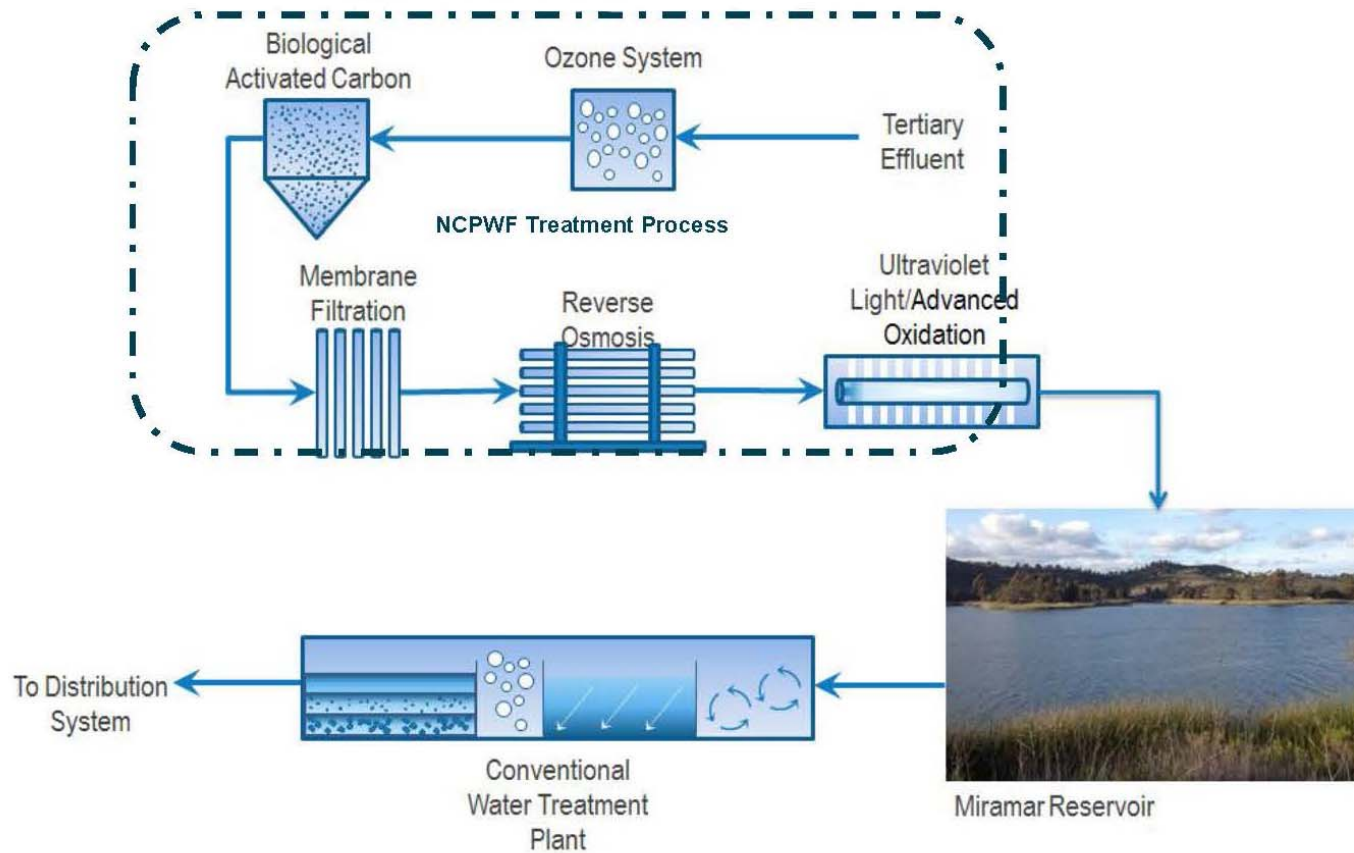

SOURCE: North City Pure Water Facility 30% Engineering Design Report, Oct. 2016

DUDEK

FIGURE 3-28
Pure Water System Overview Miramar Reservoir Alternative

INTENTIONALLY LEFT BLANK

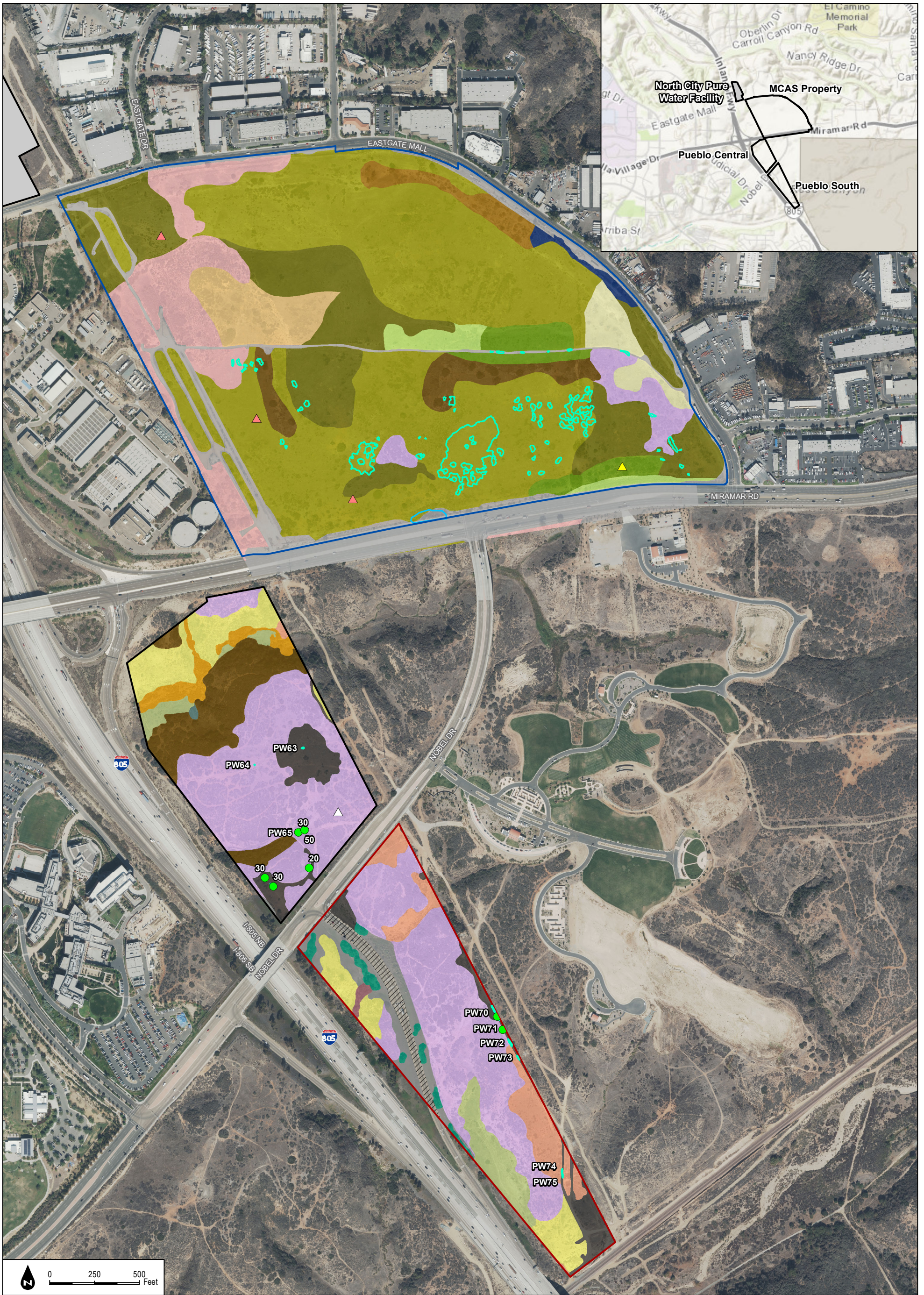

- | | | | | | | |
|--|--|--|--|--|---|---|
| <ul style="list-style-type: none"> MCAS Property Pueblo Central Pueblo South | <ul style="list-style-type: none"> ▲ Grasshopper Sparrow ▲ Least Bell's Vireo ▲ coastal California gnatcatcher ● <i>Holocarpa virgata</i> | <p>Vegetation Communities/Land Cover Types</p> <ul style="list-style-type: none"> Annual Brome Grassland Area under active management for mission/administrative use Black Sage Scrub Blackwood Acacia Disturbed Area Broom Baccharis Scrub | <ul style="list-style-type: none"> California Buckwheat Scrub California Sagebrush Scrub Chamise Chaparral Developed Diegan Coastal Sage Scrub Diegan Coastal Sage Scrub-Disturbed | <ul style="list-style-type: none"> Diegan Coastal Sage Scrub: Baccharis-dominated Disturbed Habitat Eucalyptus Woodland Festuca myuros is dominant in the herbaceous layer Native Grassland Non-native Grassland | <ul style="list-style-type: none"> Non-native Vegetation Scrub Oak Chaparral Southern Willow Scrub Upland Mustards Vernal Pool Wild Oats Grasslands | <ul style="list-style-type: none"> Waters of the US Vernal Pool Basin |
|--|--|--|--|--|---|---|

SOURCE: City San Diego, 2016, 2017; SanGIS 2017; SANDAG



Pure Water San Diego Program North City EIR/EIS

FIGURE 3-29
Alternative North City Pure Water Facility Sites

INTENTIONALLY LEFT BLANK

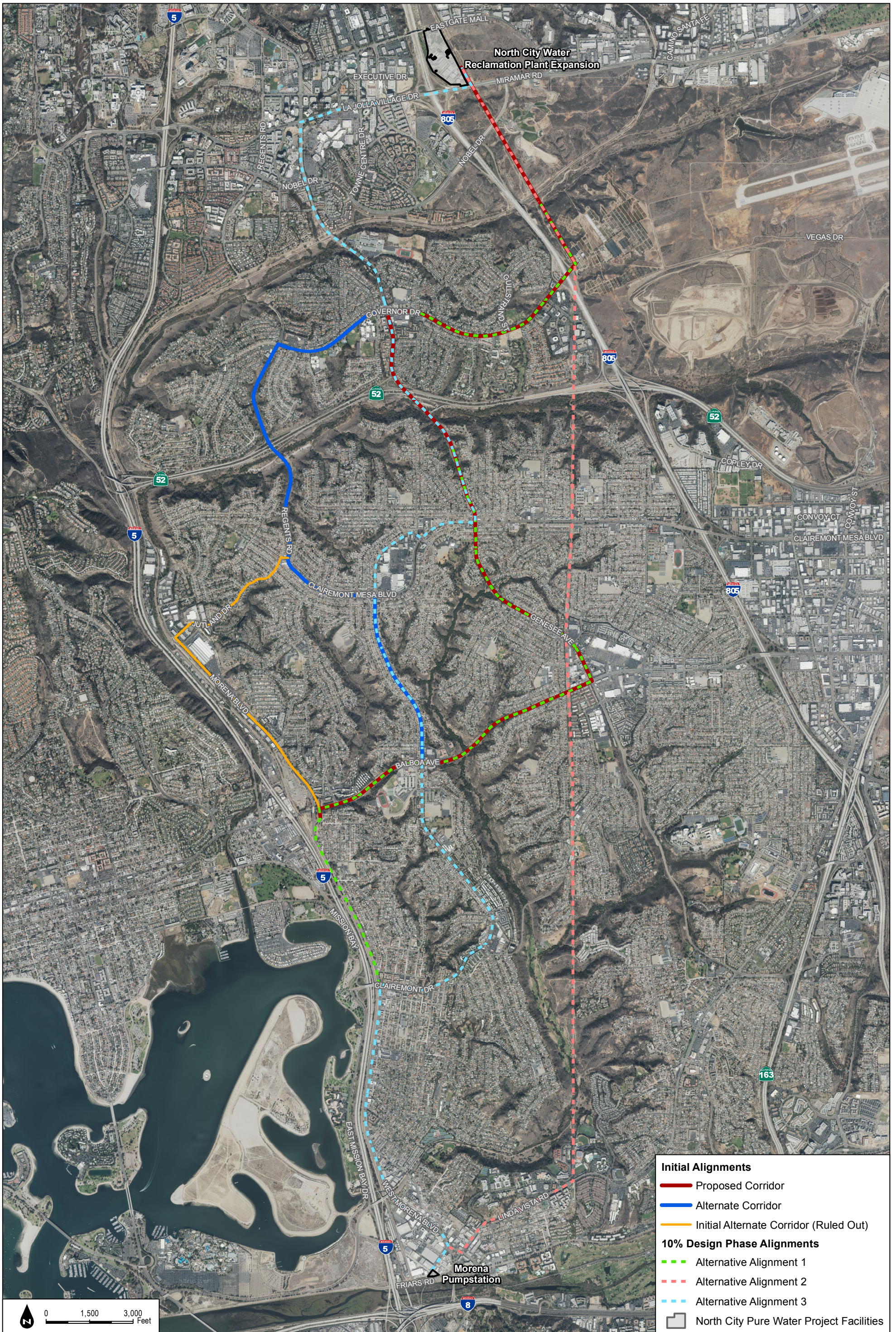

SOURCE: MWH Americas & Brown and Caldwell; Morena Pump Station, WW Foremain, and Brine Conveyance 10% Engineering Design Report, January 2016

FIGURE 3-30

Morena Wastewater Force main and Brine/Centrate Line Alternative Alignments

INTENTIONALLY LEFT BLANK

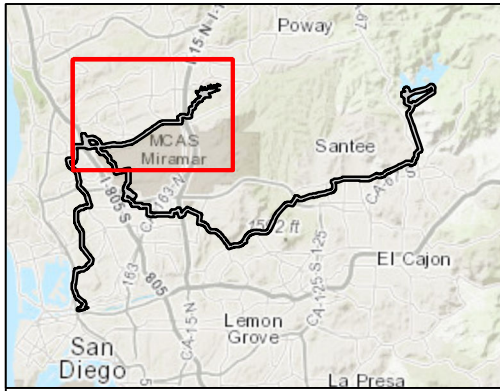

- Shared Baseline Alignment
- Alternative A (North)
- Alternative B (Central)
- Alternative C (South)
- Alignment Deviations**
- - - Alternative A (North) Deviations
- - - Alternative B (Central) Deviations
- - - Alternative C (South) Deviation
- Initial Study Options**
- - - Mira Mesa
- - - Rock Quarry
- - - CWA Easement
- - - Miramar Ranch School Easement

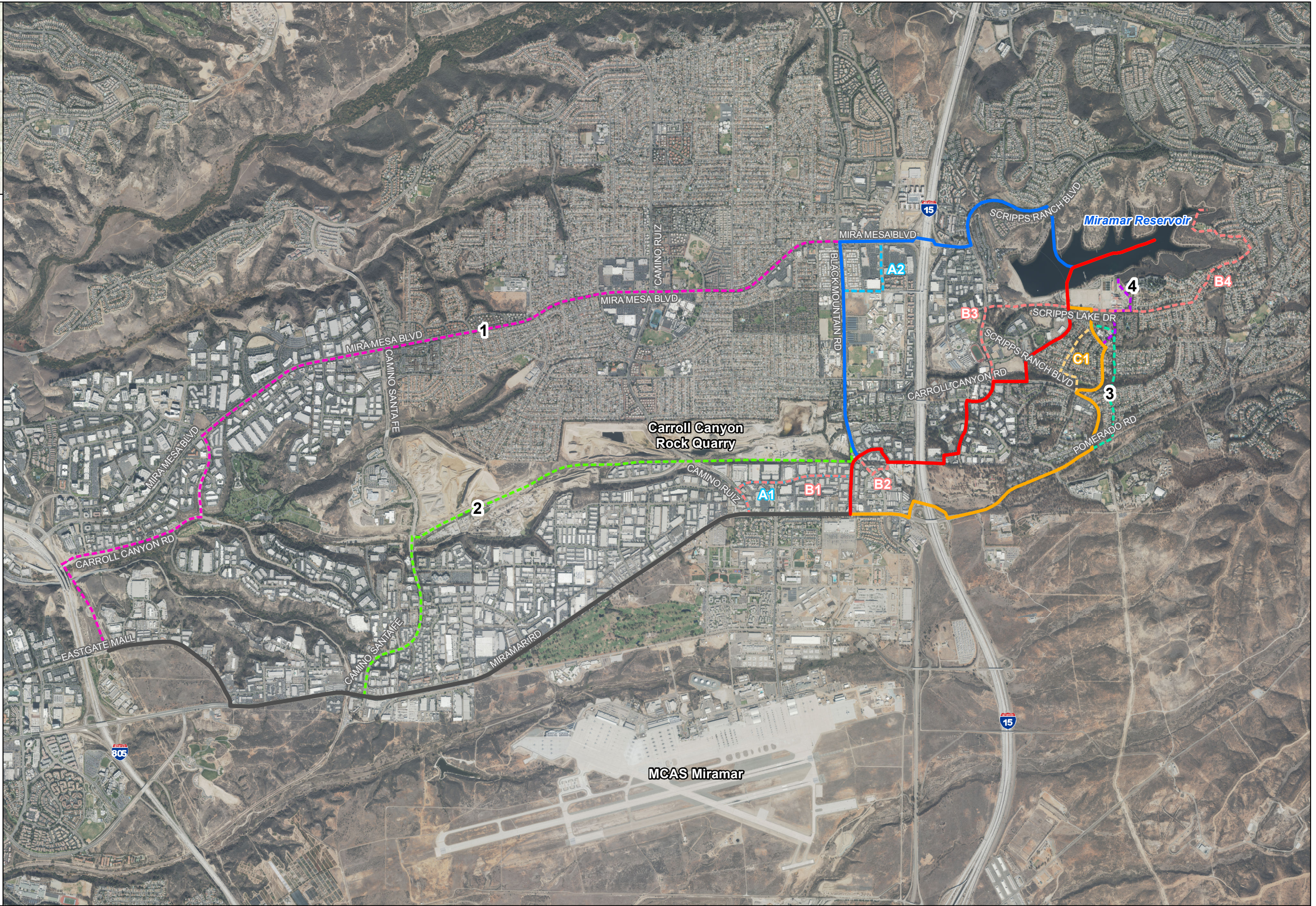

SOURCE: Brown and Caldwell, 2017; MWH, 2017; SANDAG 2014, SanGIS 2017



Pure Water San Diego Program North City Project EIR/EIS

FIGURE 3-31A
North City Pure Water Pipeline Alternative Alignments

INTENTIONALLY LEFT BLANK