

IX. Appendices

- A. Terms and Abbreviations used in this Report
- B. Methods of Analysis
- C. Frequency of Analysis and Type of Sample – 2011
- D. Laboratories Contributing Results used in this report
- E. Staff Contributing to this Report

This page left blank intentionally

A. Terms and Abbreviations used in this Report

Along with standard abbreviations the following is a list of local/uncommon abbreviations and terms for the readers' reference.

PLANT TERMS

U.S.EPA	- United States Environmental Protection Agency.
NPDES	- National Pollutant Discharge Elimination System.
WWTP	- Wastewater Treatment Plant.
WRP	- Water Reclamation Plant.
PLWTP or PLWWTP	- Pt. Loma Wastewater Treatment Plant
PLR	- Point Loma Raw (influent to the plant).
PLE	- Point Loma Effluent (effluent from the plant).
N-1-P	- North Digester Number 1, Primary, Pt. Loma
N-2-P	- North Digester Number 2, Primary, Pt. Loma
C-1-P	- Central Digester Number 1, Primary, Pt. Loma
C-2-P	- Central Digester Number 2, Primary, Pt. Loma
S-1-P	- South Digester Number 1, Primary, Pt. Loma
S-2-P	- South Digester Number 2, Primary, Pt. Loma
Dig 7	- Digester Number 7, Primary, Pt. Loma
Dig 8	- Digester Number 8, Primary, Pt. Loma
DIG COMP	- Digested Biosolids Composite; a composite of grabs taken from each of the in-service digesters.
RAW COMP	- A Composite of Raw Sludge taken over the preceding 24 hrs.
NCWRP	- North City Water Reclamation Plant
N01-PS_INF	- The plant primary Influent from Pump Station 64
N01-PEN	- The plant primary Influent from the Penasquitos pump station.
N30-DFE	- Disinfected Final Effluent
N34-REC WATER	- Reclaimed Water.
N10-PSP COMB	- raw sludge
N15-WAS LCP	- Waste Activated Sludge – low capacity pumps
SBOO	- South Bay Ocean Outfall or South Bay Outfall
SB_INF_02	- The plant Influent
SB_OUTFALL_01	- The plant discharge to ocean effluent
SB_ITP_COMB_EFF	-The plant discharge to ocean and International Waste Treatment Plant combined effluents
SB_PRI_EFF_01	- The plant primary Influent
SB_SEC_EFF_00	-The plant secondary Influent
SB_REC_WATER_34	- Reclaimed Water
SB_RSL_10	- The plant primary sedimentation tank to raw sludge line
MBC	- Metro Biosolids Center
MBCDEWCN	- Metro Biosolids Center Dewatering Centrifuges; typically the dewatered biosolids from these.
MBC_COMBCN	- MBC Combined Centrate; the centrate from all the dewatering centrifuges. (The return stream from MBC to the sewer system.)
MBC_NC_DSL	- North City to Metropolitan Biosolids Center (MBC) Digested Sludge Line.
Dig 1	- MBC Digester number 1.
Dig 2	- MBC Digester number 2.
Dig 3	- MBC Digester number 3.
Biosolids	- In most cases Biosolids and digested (a processed) Sludge is synonymous.
Field Replicate	- Separate samples collected at approximately the same time from the same sample site.

UNITS

mg/Lmilligrams per liter
ug/Lmicrograms per liter = 0.001 mg/L
ng/L nanograms per liter = 0.001 ug/L
mg/Kg milligrams per kilogram
ug/Kg micrograms per kilogram
ng/Kg nanograms per kilogram
pg/L picograms per liter
pg/Kgpicograms per kilogram
pc/L or pCi/L.... pico curies per liter
TU toxicity units
ntu nephelometric turbidity units
°Cdegrees Celsius = degrees centigrade
MGD/mgd million gallons per day
umhos/cm.micromhos per centimeter
uSmicrosiemens = umhos
mils/100 mLmillions per 100 milliliters
nd.....not detected
NA.....not analyzed (when in a data column)
NRnot required
NSnot sampled

CHEMICAL TERMS & ABBREVIATIONS:

AA.....Atomic Absorption Spectroscopy
BODBiochemical Oxygen Demand
CN⁻Cyanide
CODChemical Oxygen Demand
Cr⁶⁺Hexavalent Chromium
D.O.....Dissolved Oxygen
DDDDichlorodiphenyldichloroethane
a.k.a. TDE-tetrachlorodiphenylethane)
DDEDichlorodiphenyldichloroethylene
DDTDichlorodiphenyltrichloroethane
FeCl₃Ferric Chloride
G&O.....Grease and Oil
GCGas chromatography.
GC-ECD.....-Electron Capture Detector.
GC-FID-Flame Ionization Detector.
GC-FPD-Flame Photometric Detector.
GC-MS.....-Mass Spectroscopy.
H₂SHydrogen Sulfide
Hg.....Mercury
ICIon Chromatography
InductICP-AES Inductively Coupled Plasma-
Atomic Emission Spectroscopy
MDL.....Method Detection Limit
MSD.....Mass Spectroscopy Detector
NH₃Ammonia
NH₃-NAmmonia Nitrogen
NH₄⁺Ammonium ion
NO₃⁻Nitrate
PADPulsed Amperometric Detector
PCBPolychlorinated Biphenyls
PO₄³⁻Phosphate
SO₄²⁻Sulfate
SSSuspended Solids
TBTTributyl tin
TCHTotal Chlorinated Hydrocarbons
(i.e. chlorinated pesticides & PCB's)
TCLP.. Toxicity Characteristic Leaching Procedure
TDSTotal Dissolved Solids
TS.....Total Solids
TVSTotal Volatile Solids
VSSVolatile Suspended Solids

B. Methods of Analysis

WASTEWATER INFLUENT and EFFLUENT (General)

Analyte	Description	Instrumentation	Reference ¹
Alkalinity	Selected Endpoint Titration	Mettler DL-21 & 25 Titrator Orion 950	(i) 2320 B
Ammonia Nitrogen	Distillation and Titration	Buchi Distillation Unit K-314, B-324, K-350 Orion 950 pH Meter Mettler DL25 titrator	(i) 4500-NH3 B & C
Biochemical Oxygen Demand (BOD-5 Day)	Dissolved Oxygen Meter with Dissolved Oxygen Probe	YSI-5000 DO Meter YSI-5100 DO Meter YSI 59 DO Meter (5905 Probe)	(i) 5210 B
Biochemical Oxygen Demand (BOD-Soluble)	Dissolved Oxygen Probe	YSI-5000 DO Meter YSI-5100 DO Meter YSI 59 DO Meter (5905 Probe)	(i) 5210 B
Chemical Oxygen Demand (COD)	Closed Reflux / Colorimetric	Hach DR-2010 UV/Vis spectrophotometer	HACH 8000
Conductivity	Conductivity Meter with Wheatstone Bridge probe	YSI-3100, YSI-3200, Orion 115A, Orion 250, Accumet Model 150	(g) 2510 B
Cyanide	Acid Digest/Distil./Colorimetric	Hach DR-4000/Vis	(i) 4500-CN E
Floating Particulates	Flotation Funnel	Mettler AX-105 Mettler AG 204 Balance	(g) 2530 B
Flow	Continuous Meter	Gould (pressure sensor), ADS (sonic sensor), or Venturi (velocity sensor)	
Hardness; Ca, Mg, Total	ICP-AES / Calculation	TJA IRIS	(a) 200.7 (h) 2340 B
Kjeldahl Nitrogen (TKN)	Macro-Digestion / Titration	Labconco digestion block Buchi B-324 distiller & Mettler DL25 titrator	(i) Digestion= 4500-Norg B
Oil and Grease	Hexane Extraction / Gravimetric	Mettler AX-105 Balance	(a) 1664A
Organic Carbon (TOC)	Catalytic Oxidation / IR Water Production Laboratory)	Shimadzu ASI-5000	(f) 5310 B
pH	Hydrogen+Reference Electrode	Various models of pH meters.	(i) 4500-H+ B
Radiation (alpha & beta)	Alpha Spectroscopy Gamma Spectroscopy	Canberra 7401 (alpha) Canberra GC25185 (beta)	(h) 7110 B
Solids, Dissolved-Total	Gravimetric @ 180°C using analytical balance	Mettler AG204, AX105, AB204	(i) 2540 C
Solids, Settleable	Volumetric	Imhoff Cone	(i) 2540 F
Solids, Suspended-Total	Gravimetric @ 103-105°C	Mettler AG204, AX105, AB204	(i) 2540 D
Solids, Suspended-Volatile	Gravimetric @ 500°C	Mettler AG204, AX105, AB204	(i) 2540 E
Solids, Total	Gravimetric @ 103-105°C	Mettler AG204, AX105, AB204	(a) 160.3
Solids, Total-Volatile	Gravimetric @ 500°C	Mettler AG204, AX105, AB204	(a) 160.4
Temperature	Direct Reading	Fisher Digital Thermometer	(g) 2550 B
Turbidity	Nephelometer Turbidimeter	Hach 2100-N Meter Hach 2100-AN Meter	(g) 2130 B
Bromide, Chloride, Fluoride, Nitrate, Phosphate, Sulfate	Ion Chromatography	Dionex ICS-3000	(d) 300.0

¹ Reference listing is found following this listing of analytical methods.

WASTEWATER INFLUENT and EFFLUENT (Metals)

Analyte	Description	Instrumentation	Reference ¹
Aluminum	Acid Digestion / ICP-AES	TJA IRIS	(e) 200.7
Antimony	Acid Digestion / ICP-AES	TJA IRIS	(e) 200.7
Arsenic	Hydride Generation / AA	TJA Solaar M6	(h) 3114 C
Barium	Acid Digestion / ICP-AES	TJA IRIS	(e) 200.7
Beryllium	Acid Digestion / ICP-AES	TJA IRIS	(e) 200.7
Boron	Acid Digestion / ICP-AES	TJA IRIS	(e) 200.7
Cadmium	Acid Digestion / ICP-AES	TJA IRIS	(e) 200.7
Calcium	Acid Digestion / ICP-AES	TJA IRIS	(e) 200.7
Chromium	Acid Digestion / ICP-AES	TJA IRIS	(e) 200.7
Cobalt	Acid Digestion / ICP-AES	TJA IRIS	(e) 200.7
Copper	Acid Digestion / ICP-AES	TJA IRIS	(e) 200.7
Iron	Acid Digestion / ICP-AES	TJA IRIS	(e) 200.7
Lead	Acid Digestion / ICP-AES	TJA IRIS	(e) 200.7
Lithium	Acid Digestion / ICP-AES	TJA IRIS	(e) 200.7
Magnesium	Acid Digestion / ICP-AES	TJA IRIS	(e) 200.7
Manganese	Acid Digestion / ICP-AES	TJA IRIS	(e) 200.7
Mercury	Thermal / AA	Milestone DMA80	(g) 3112 B
Mercury	Cold Vapor Generation / AF	Leeman Hydra Gold	(w) 1613E and 245.7
Molybdenum	Acid Digestion / ICP-AES	TJA IRIS	(e) 200.7
Nickel	Acid Digestion / ICP-AES	TJA IRIS	(e) 200.7
Potassium	Acid Digestion / ICP-AES	TJA IRIS	(e) 200.7
Selenium	Hydride Generation / AA	TJA Solaar M6	(h) 3114 C
Silver	Acid Digestion / ICP-AES	TJA IRIS	(e) 200.7
Sodium	Acid Digestion / ICP-AES	TJA IRIS	(e) 200.7
Thallium	Acid Digestion / ICP-AES	TJA IRIS	(e) 200.7
Vanadium	Acid Digestion / ICP-AES	TJA IRIS	(e) 200.7
Zinc	Acid Digestion / ICP-AES	TJA IRIS	(e) 200.7

- 1 Reference listing is found following this listing of analytical

WASTEWATER INFLUENT and EFFLUENT (Organics)

Analyte	Description	Instrumentation	Reference ¹
Acrolein and Acrylonitrile	Purge & Trap, GC-MSD	O-I Analytical Eclipse 4660/4552 Agilent-6890NGC /5973N MSD Capillary J&W DB-624	(c) 8260 B
Base/Neutral Extractables	Basic / CH ₂ Cl ₂ continuous extraction, GC-MSD	HP-6890GC / 5973MSD Capillary DB-5.625	(a) 625
Benzidines	Basic / CH ₂ Cl ₂ continuous extraction, GC-MSD	HP-6890GC / 5973MSD Capillary DB-5.625	(a) 625
Chlorinated Compounds	CH ₂ Cl ₂ extraction, GC-ECD	Varian 3800 GC-ECD RTX-5/60m : RTX-1701/60m Varian 3800-Saturn 2000 DB-XLB	(a) 608
Dioxin	CH ₂ Cl ₂ extraction, GC/MS/MS	Varian Saturn -MS-MS Varian 3800 GC	(a) 8280A
Organophosphorus Pesticides	CH ₂ Cl ₂ extraction, hexane exchange, GC-PFPD	Varian 3800 GC-PFPD RTX-1 :RTX-50	(a) 622
Phenolic Compounds	Acidic / CH ₂ Cl ₂ continuous extraction, GC-MSD	HP-6890GC / 5973MSD Capillary DB-5.625	(a) 625
Purgeables (VOCs)	Purge & Trap, GC-MSD	O-I Analytical Eclipse 4660/4552 Agilent-6890NGC /5973N MSD Capillary J&W DB-624	(a) 8260B
Tri, Di, and Monobutyl Tin	CH ₂ Cl ₂ extraction, derivatization, hexane exchange, GC-FPD	Varian 3400 GC-FPD DB-1/30m : RTX-50	(l)

¹ Reference listing is found following this listing of analytical methods.

LIQUID SLUDGE: Raw, Digested, and Filtrate (General)

Analyte	Description	Instrumentation	Reference ¹
Alkalinity	Selected Endpoint Titration	Mettler DL-25 Titrator Orion 950	(g) 2320 B
Cyanide	Acid Digest-Distil / Colorimetric	Hach DR/4000V	(h) 4500-CN E
pH	Hydrogen+Reference Electrode	Various models of pH meters.	(c) 9010 B
Radiation (alpha & beta)	Alpha Spectroscopy Gamma Spectroscopy	Canberra 7401 (alpha) Canberra GC25185 (beta)	(h) 7110 B
Sulfides	Acid Digest-Distil / Titration	Class A Manual Buret	(c) 9030 B
Sulfides, reactive	Distillation / Titration	Class A Manual Buret	(c) 7.3.4.2
Solids, Total	Gravimetric @ 103-105°C	Mettler PB 4002-S Mettler PG 5002-S Mettler AB204	(i) 2540 B
Solids, Total-Volatile	Gravimetric @ 500°C	Mettler PB 4002-S Mettler PG 5002-S Mettler AB204	(i) 2540 E

LIVID SLUDGE: Raw, Digested, and Filtrate (Metals)

Analyte	Description	Instrumentation	Reference ¹
Aluminum	Acid Digestion / ICP-AES	TJA IRIS	(c) 6010 B
Antimony	Acid Digestion / ICP-AES	TJA IRIS	(c) 6010 B
Arsenic	Hydride Generation / AA	TJA Solaar M6	(c) 7062
Beryllium	Acid Digestion / ICP-AES	TJA IRIS	(c) 6010 B
Barium	Acid Digestion / ICP-AES	TJA IRIS	(c) 6010 B
Boron	Acid Digestion / ICP-AES	TJA IRIS	(c) 6010 B
Cadmium	Acid Digestion / ICP-AES	TJA IRIS	(c) 6010 B
Chromium	Acid Digestion / ICP-AES	TJA IRIS	(c) 6010 B
Cobalt	Acid Digestion / ICP-AES	TJA IRIS	(c) 6010 B
Copper	Acid Digestion / ICP-AES	TJA IRIS	(c) 6010 B
Iron	Acid Digestion / ICP-AES	TJA IRIS	(c) 6010 B
Lead	Acid Digestion / ICP-AES	TJA IRIS	(c) 6010 B
Manganese	Acid Digestion / ICP-AES	TJA IRIS	(c) 6010 B
Mercury	Thermal / AA	Milestone DMA80	(c) 7471 A and 747.3
Mercury	TD / AA	Milestone DMA80	(c) 7471 A
Molybdenum	Acid Digestion / ICP-AES	TJA IRIS	(c) 6010 B
Nickel	Acid Digestion / ICP-AES	TJA IRIS	(c) 6010 B
Selenium	Hydride Generation / AA	TJA Solaar M6	(c) 7742
Silver	Acid Digestion / ICP-AES	TJA IRIS	(c) 6010 B
Thallium	Acid Digestion / ICP-AES	TJA IRIS	(c) 6010 B
Vanadium	Acid Digestion / ICP-AES	TJA IRIS	(c) 6010 B
Zinc	Acid Digestion / ICP-AES	TJA IRIS	(c) 6010 B

¹ Reference listing is found following this listing of analytical methods.

LIVID SLUDGE: Raw, Digested, and Decant (Organics)

Analyte	Description	Instrumentation	Reference ¹
Acrolein and Acrylonitrile	Purge & Trap, GC-MSD	O-I Analytical Eclipse 4660/4552 Agilent-6890NGC /5973N MSD Capillary J&W DB-624	(c) 8260 B (b)
Base/Neutral Extractables	Basic / CH ₂ Cl ₂ continuous extraction, GC-MSD	HP-6890GC / 5973MSD Capillary DB-5.625	(a) 625 (b)
Benzidines	Basic / CH ₂ Cl ₂ continuous extraction, GC-MSD	HP-6890GC / 5973MSD Capillary DB-5.625	(a) 625
Chlorinated Compounds	CH ₂ Cl ₂ extraction, GC-ECD	Varian 3800 GC-ECD RTX-5/60m : RTX-1701/60m Varian 3800-Saturn 2000 DB-XLB	(c) 8081 A
PCBs	CH ₂ Cl ₂ extraction, GC-ECD	Varian 3800 GC-ECD RTX-5/60m : RTX-1701/60m Varian 3800-Saturn 2000 DB-XLB	(c) 8082
Dioxin	CH ₂ Cl ₂ extraction	Varian GC-MS/MS	(c) 8280A
Organophosphorus Pesticides	CH ₂ Cl ₂ extraction, hexane exchange, GC-PFPD	Varian 3800 GC-PFPD RTX-1 : RTX-50	(a) 622
Phenolic Compounds	Acidic / CH ₂ Cl ₂ continuous extraction, GC-MSD	HP-6890GC / 5973MSD Capillary DB-5.625	(a) 625 (b)
Purgeables (VOCs)	Purge & Trap, GC-MSD	O-I Analytical Eclipse 4660/4552 Agilent-6890NGC /5973N MSD Capillary J&W DB-624	(c) 8260 B (b)
Tri, Di, and Monobutyl Tin	CH ₂ Cl ₂ extraction, derivatization, hexane exchange, GC-FPD	Varian 3400 GC-FPD DB-1/30m : RTX-50	(l)

LIVID SLUDGE: Raw, Digested, and Decant (Digester Gases)

Analyte	Description	Instrumentation	Reference ¹
Methane	Gas Chromatography	SRI 8610C GC EG&G 100AGC	(i) 2720 C
Carbon Dioxide	Gas Chromatography	SRI 8610C GC EG&G 100AGC	(i) 2720 C

Hydrogen Sulfide	Colorimetric	Draeger H2S 2/a	
------------------	--------------	-----------------	--

1 Reference listing is found following this listing of analytical methods.

DRIED SLUDGE: Metro Biosolids Center (General)

Analyte	Description	Instrumentation	Reference ¹
Cyanide	Acid Digest-Distillation Colorimetric	Hach DR/4000V UV/Vis	(c) 9010 A
Cyanide Reactive	Distillation / Colorimetric	Hach DR/4000V UV/Vis	(c) 7.3.3.2 and 9014
pH	Hydrogen+Reference Electrode	Various models of pH meters.	(c) 9045 C
Radiation (alpha & beta)	Alpha Spectroscopy Gamma Spectroscopy	Canberra 7401 (alpha) Canberra GC25185 (beta)	(h) 7110 B
Sulfides	Acid Digest-Distil / Titration	Class A Manual Buret	(c) 9030 B and 9034
Sulfides, reactive	Distillation / Titration	Class A Manual Buret	(c) 7.3.4.2 and 9034
Solids, Total	Gravimetric @ 103-105 C°	Denver PI-314, Mettler AB204	(i) 2540 B
Solids, Total-Volatile	Gravimetric @ 500 C°	Denver PI-314, Mettler AB204	(i) 2540 E

DRIED SLUDGE: Metro Biosolids Center (Metals)

Analyte	Description	Instrumentation	Reference ¹
Aluminum	Acid Digestion / ICP-AES	TJA IRIS	(c) 6010 B
Antimony	Acid Digestion / ICP-AES	TJA IRIS	(c) 6010 B
Arsenic	Hydride Generation / AA	TJA Solaar M6	(c) 7062
Barium	Acid Digestion / ICP-AES	TJA IRIS	(c) 6010 B
Beryllium	Acid Digestion / ICP-AES	TJA IRIS	(c) 6010 B
Boron	Acid Digestion / ICP-AES	TJA IRIS	(c) 6010 B
Cadmium	Acid Digestion / ICP-AES	TJA IRIS	(c) 6010 B
Chromium	Acid Digestion / ICP-AES	TJA IRIS	(c) 6010 B
Cobalt	Acid Digestion / ICP-AES	TJA IRIS	(c) 6010 B
Copper	Acid Digestion / ICP-AES	TJA IRIS	(c) 6010 B
Iron	Acid Digestion / ICP-AES	TJA IRIS	(c) 6010 B
Lead	Acid Digestion / ICP-AES	TJA IRIS	(c) 6010 B
Manganese	Acid Digestion / ICP-AES	TJA IRIS	(c) 6010 B
Mercury	Thermal / AA	Milestone DMA80	(c) 7471 A
Mercury	TD / AA	Leeman Hydra Gold	(c) 7471 A
Molybdenum	Acid Digestion / ICP-AES	TJA IRIS	(c) 6010 B
Nickel	Acid Digestion / ICP-AES	TJA IRIS	(c) 6010 B
Selenium	Hydride Generation / AA	TJA Solaar M6	(c) 7742
Silver	Acid Digestion / ICP-AES	TJA IRIS	(c) 6010 B
Thallium	Acid Digestion / ICP-AES	TJA IRIS	(c) 6010 B
Vanadium	Acid Digestion / ICP-AES	TJA IRIS	(c) 6010 B
Zinc	Acid Digestion / ICP-AES	TJA IRIS	(c) 6010 B

Waste Extraction Test (WET)	Extraction with Sodium Citrate ICP-AES	Burrel wrist action shaker TJA IRIS	(j) Section 66261.100
-----------------------------	--	--	-----------------------

1 Reference listing is found following this listing of analytical methods.

DRIED SLUDGE: Metro Biosolids Center (Organics)

Analyte	Description	Instrumentation	Reference ¹
Acrolein and Acrylonitrile	Purge & Trap, GC-MSD	O-I Analytical Eclipse 4660/4552 Agilent-6890NGC /5973N MSD Capillary J&W DB-624	(c) 8260 B
Base/Neutral Extractables	CH2Cl2 /Acetone sonication extraction, GC-MSD	Agilent-7890GC / 5975MSD Capillary DB-5.625	(c) 8270 C (c) 3550 A
Chlorinated Compounds	CH2Cl2 extraction, GC-ECD	Varian 3800 GC-ECD RTX-5/60m : RTX-1701/60m	(c) 8081 A

		Varian 3800-Saturn 2000 DB-XLB	
PCBs	CH ₂ Cl ₂ extraction, GC-ECD	Varian 3800 GC-ECD RTX-5/60m : RTX-1701/60m Varian 3800-Saturn 2000 DB-XLB	(c) 8082
Dioxin	Outside Contact (Test America)	GC-MS	(a) 8290
Organophosphorus Pesticides	CH ₂ Cl ₂ extraction, hexane exchange, GC-PFPD	Varian 3800 GC-PFPD DB-1/30m DB-608/30m	(c) 8141 A
Phenolic Compounds	CH ₂ Cl ₂ / Acetone sonication extraction, GC-MSD	HP-5890GC / 5972MSD Agilent-78906GC / 5975MSD Capillary DB-5.625	(c) 8270 C (c) 3550 A
Purgeables (VOCs)	Purge & Trap, GC-MSD	O-I Analytical Eclipse 4660/4552 Agilent-6890NGC /5973N MSD Capillary J&W DB-624	(c) 8260 B
Tri, Di, and Monobutyl Tin	CH ₂ Cl ₂ extraction, derivatization, hexane exchange, GC-FPD	Varian 3400 GC-FPD DB-1/30m DB-608/30m	(l)
Total Nitrogen (TN)	Combustion / GC-TCD	Carlo-Erba NC-2500 Porapak QS	(m) 9060

1 Reference listing is found following this listing of analytical methods.

OCEAN SEDIMENT (General)

Analyte	Description	Instrumentation	Reference ¹
Biochemical Oxygen Demand (BOD-5 Day)	Dissolved Oxygen Probe	YSI-5000 DO Meter	(g) 5210 B
Particle Size	Coarse fraction by sieve; fine fraction by laser scatter	Horiba LA-920	(q) 3-380
Sulfides	Acid Digest-Distil / IC-PAD	Dionex ICS 3000-PAD(Ag)	(k)
Solids, Total	Gravimetric @ 103-105 C°	AND HM-120	(g) 2540 B
Solids, Total-Volatile	Gravimetric @ 500 C°	AND HM-120	(g) 2540 E
Total Organic Carbon (TOC) and Total Nitrogen (TN)	Combustion / GC-TCD	Carlo-Erba NC-2500 Porapak QS	(c) 9060 (m)

OCEAN SEDIMENT (Metals)

Analyte	Description	Instrumentation	Reference ¹
Aluminum	Acid Digestion / ICP-AES	TJA IRIS	(c) 6010 B
Antimony	Acid Digestion / ICP-AES	TJA IRIS	(c) 6010 B
Arsenic	Hydride Generation / AA	TJA Solaar M6	(c) 7062
Beryllium	Acid Digestion / ICP-AES	TJA IRIS	(c) 6010 B
Cadmium	Acid Digestion / ICP-AES	TJA IRIS	(c) 6010 B
Chromium	Acid Digestion / ICP-AES	TJA IRIS	(c) 6010 B
Copper	Acid Digestion / ICP-AES	TJA IRIS	(c) 6010 B
Iron	Acid Digestion / ICP-AES	TJA IRIS	(c) 6010 B
Lead	Acid Digestion / ICP-AES	TJA IRIS	(c) 6010 B
Manganese	Acid Digestion / ICP-AES	TJA IRIS	(c) 6010 B
Mercury	Thermal / AA	Milestone DMA80	(c) 7471 A
Mercury	Cold Vapor Generation / AF	Leeman Hydra Gold	(c) 7471 A
Nickel	Acid Digestion / ICP-AES	TJA IRIS	(c) 6010 B
Selenium	Hydride Generation / AA	TJA Solaar M6	(c) 7742
Silver	Acid Digestion / ICP-AES	TJA IRIS	(c) 6010 B
Thallium	Acid Digestion / ICP-AES	TJA IRIS	(c) 6010 B
Tin	Acid Digestion / ICP-AES	TJA IRIS	(c) 6010 B
Zinc	Acid Digestion / ICP-AES	TJA IRIS	(c) 6010 B

OCEAN SEDIMENT (Organics)

Analyte	Description	Instrumentation	Reference ¹
Base/Neutral Extractables	CH ₂ Cl ₂ / Acetone ASE GC-MSD	Agilent-7890GC / 5975MSD Capillary DB-5.625	(c) 8270 C (b) 3545A
Chlorinated Compounds	CH ₂ Cl ₂ extraction, GC-ECD/MS/MS	Varian Saturn GC-ECD/MS/MS DBXLB/60m	(c) 8081 A 3545A
PCBs as Congeners	CH ₂ Cl ₂ extraction, GC-ECD/MS/MS	Varian Saturn GC-ECD/MS/MS DBXLB/60m	(c) 8082 3545A
Organophosphorus Pesticides	CH ₂ Cl ₂ extraction, hexane exchange, GC-PFPD	Varian 3800 GC-PFPD RTX-1 : RTX-50	(c) 8141 A
Tri, Di, and Monobutyl Tin	CH ₂ Cl ₂ extraction, derivatization, hexane exchange, GC-FPD	Varian 3400 GC-FPD DB-1/30m : RTX_50	(l)

¹ Reference listing is found following this listing of analytical methods.

FISH TISSUE: Liver, Muscle, and Whole (General)

Analyte	Description	Instrumentation	Reference ¹
Solids, Total	Freeze Drying Gravimetric	Labconco Freezone 6 Mettler AG-104 Balance	(n)
Lipids	Hexane/Acetone Extraction Gravimetric	Dionex ASE-200 Mettler AG-104 Balance	(o)

FISH TISSUE: Liver, Muscle, and Whole (Metals)

Analyte	Description	Instrumentation	Reference ¹
Aluminum	Acid Digestion / ICP-AES	TJA IRIS	(e) 200.3 / 200.7
Antimony	Acid Digestion / ICP-AES	TJA IRIS	(e) 200.3 / 200.7
Arsenic	Acid Digestion / ICP-AES	TJA IRIS	(e) 200.3 / 200.7
Beryllium	Acid Digestion / ICP-AES	TJA IRIS	(e) 200.3 / 200.7
Cadmium	Acid Digestion / ICP-AES	TJA IRIS	(e) 200.3 / 200.7
Chromium	Acid Digestion / ICP-AES	TJA IRIS	(e) 200.3 / 200.7
Copper	Acid Digestion / ICP-AES	TJA IRIS	(e) 200.3 / 200.7
Iron	Acid Digestion / ICP-AES	TJA IRIS	(e) 200.3 / 200.7
Lead	Acid Digestion / ICP-AES	TJA IRIS	(e) 200.3 / 200.7
Manganese	Acid Digestion / ICP-AES	TJA IRIS	(e) 200.3 / 200.7
Mercury	Thermal / AA	Milestone DMA80	(e) 7473
Mercury	Cold Vapor Generation / AF	Leeman PS Hydra Gold	(w) 1631E
Nickel	Acid Digestion / ICP-AES	TJA IRIS	(e) 200.3 / 200.7
Selenium	Hydride Generation / AA	TJA Solaar M6	(c) 7742
Silver	Acid Digestion / ICP-AES	TJA IRIS	(e) 200.3 / 200.7
Thallium	Acid Digestion / ICP-AES	TJA IRIS	(e) 200.3 / 200.7
Tin	Acid Digestion / ICP-AES	TJA IRIS	(e) 200.3 / 200.7
Zinc	Acid Digestion / ICP-AES	TJA IRIS	(e) 200.3 / 200.7

FISH TISSUE: Liver, Muscle, and Whole (Organics)

Analyte	Description	Instrumentation	Reference ¹
Base/Neutral Extractables	Basic / CH ₂ Cl ₂ ASE extraction, GC-MSD	Dionex ASE-200 Agilent-7890GC/5975 MSD Capillary DB-5625	(c) 3545 / 8270 C
Chlorinated Compounds	CH ₂ Cl ₂ extraction, GC-ECD/MS/MS	Varian 3800 GC Saturn 2000 MS-Ion Trap DB-XLB/60m	(c) 3545 / 8081 A
PCBs	CH ₂ Cl ₂ extraction, hexane exchange, GC-ECD/MS/MS	Varian 3800 GC Saturn 2000 MS-Ion Trap DB-XLB/60m	(c) 3545 / 8082

¹ Reference listing is found following this listing of analytical methods.

Method References: Methods of Analysis Used to Produce the Data Presented in this Report.

- a) Methods for Chemical Analysis of Water and Wastes, EPA, Environmental Monitoring and Support Laboratory, Cincinnati, Ohio, March 1979 (EPA-600/4-79-020), 1983 Revision, and March 1984 (EPA-600/4-84-017).
- b) U.S. EPA Contract Laboratory Program, Statement of Work for Organic Analysis, Multi-Media, Multi-Concentration, 7/85 revision and 1/91 revision.
- c) Test Methods for Evaluating Solid Waste, Physical/Chemical Methods, U.S. EPA Office of Solid Waste and emergency Response, Washington, D.C. 20460, November 1986, SW-846, Third Edition. Revision 0 September 1994, December 1996, Revision 2
- d) The Determination of Inorganic Anions in Water by Ion Chromatography, Revision 2.1, August 1993
- e) The Determination of Metals and Trace Elements in Water and Waste Revision 4.4, EMMC Version, EMMC Methods Work Group, 1994
- f) Standard Methods for the Examination of Water and Wastewater, APHA, AWWA, WPCF, 17th Edition, 1989.
- g) Standard Methods for the Examination of Water and Wastewater, APHA, AWWA, WPCF, 18th Edition, 1992.
- h) Standard Methods for the Examination of Water and Wastewater, APHA, AWWA, WPCF, 19th Edition, 1995.
- i) Standard Methods for the Examination of Water and Wastewater, APHA, AWWA, WPCF, 20th Edition, 1998.
- j) Criteria for Identification of Hazardous and Extremely Hazardous Wastes, California Code of Regulations (CCR), Title 22.
- k) DIONEX AU 107, R.D.Rocklin and E.L.Johnson, ANAL. CHEM., 1986, 55, 4
- l) Adaptation of method by the Naval Ocean Systems Center, San Diego, Marine Environment Branch, San Diego, CA 92152-5000
- m) "TOC/TN in Marine Sediments...", SCCWRP Annual Report, 1990-1991, and 1991-1992.
- n) "A Guide to Freeze Drying for the Laboratory...", LABCONCO, 3-53-5/94-Rosse-5M-R3, 1994.
- o) "Lipids Content in Fish Tissues via Accelerated Solvent Extraction...", WWChem, EMTS/MWWD, 1998
- v) Procedures for Handling and Chemical Analysis of Sediment and Water Samples, Russel H. Plumb, Jr., May 1981, EPA/Corp of Engineers Technical Committee on Criteria for Dredged and Fill Material, EPA Contract 4805572010.

C. Frequency of Analysis and Type of Sample - 2011

1. Definitions.

D= Daily W= Weekly M= Monthly Q= Quarterly S= Semi-Annual

Constituent	Type of Sample	FREQUENCY OF ANALYSIS			
		Influent	Effluent	Comb_Effluent	Reclaim
Permit Required Testing					
Flow	Recorder/Totalizer	Continuous	Continuous		Continuous
Biochemical Oxygen Demand - Total (5-day)	24hr Composite	D	D	Q	D
Oil and Grease	Grab		W	Q	
pH	Grab		D	Q	D
Settleable Solids	Grab		W	Q	
Temperature			W	Q	
Total Suspended Solids	24hr Composite	D	D	Q	D
Volatile Suspended Solids	24hr Composite				D
Total Dissolved Solids	24hr Composite				M
Turbidity	24hr Composite		W	Q	W
Dissolved Oxygen	Grab		W	Q	
Total Residual Chlorine	Grab		W	Q	
As,Cd,Cr,Cu,Pb,Hg,Ni,Ag,Zn	24hr Composite	M	M	Q	
Sb, Be, Tl	24hr Composite		M	Q	
Se	24hr Composite		M	Q	
Fe, Mn, B					M
Anions (Chloride, Sulfate, Nitrate as N, Fluoride)	24hr Composite				M
Ammonia-Nitrogen	24hr Composite		M	Q	
MBAS	24hr Composite				M
Cyanide	24hr Composite	M	M	Q	
Acrolein and Acrylonitrile	Grab		Q	Q	
Base/Neutral Compounds	24hr Composite		Q	Q	
Benzidines	24hr Composite		Q	Q	
Dioxin	24hr Composite		M	Q	
Percent Sodium	24hr Composite				M
Pesticides, chlorinated	24hr Composite		M	Q	
Phenols, non-chlorinated	24hr Composite		M	Q	
Phenols, chlorinated	24hr Composite		M	Q	
Polychlorinated Biphenyls	24hr Composite		Q	Q	
Purgeable (Volatile) Compounds	Grab		Q	Q	
Tri, Di, & monobutyl tins	24hr Composite		Q	Q	
Radiation	24hr Composite		M	Q	
Toxicity (Acute & Chronic)*	24hr Composite		W	Q	

*Reported monthly in the Toxicity Testing Report by the Biology Section.

D= Daily W= Weekly M= Monthly Q= Quarterly S= Semi-Annual

Constituent	Type of Sample	FREQUENCY OF ANALYSIS			
		Influent	Effluent	Comb_Effluent	Reclaim
Additional Testing					
Total Dissolved Solids	24hr Composite	D			
Volatile Suspended Solids	24hr Composite	D			
Pesticides, organophosphorus	24hr Composite	S	S	S	S
Cations (Ca ²⁺ , Mg ²⁺ , Li ⁺ , Na ⁺ , K ⁺)	24hr Composite	M	M	Q	M
Anions	24hr Composite	M	M	Q	
Fe	24hr Composite	M	M	Q	
Oil and Grease	Grab	Q			Q
pH	Grab	D			
Settleable Solids	Grab	Q			
MBAS	24hr Composite	Q	Q	Q	
Turbidity	24hr Composite	Q			Continuos
Sb, Be, Tl	24hr Composite	M			M
Se	24hr Composite	M			M
Ammonia-Nitrogen	24hr Composite	Q			Q
Cyanide	24hr Composite				Q
Acrolein and Acrylonitrile	Grab	Q			Q
Base/Neutral Compounds	24hr Composite	Q			Q
Benzidines	24hr Composite	Q			Q
Dioxin	24hr Composite	M			Q
Pesticides, chlorinated	24hr Composite	Q			Q
Phenols, non-chlorinated	24hr Composite	Q			Q
Phenols, chlorinated	24hr Composite	Q			Q
Polychlorinated Biphenyls	24hr Composite	Q			Q
Tri, Di, & monobutyl tins	24hr Composite	Q			Q
Percent Sodium	24hr Composite		M	Q	
Purgeable (Volatile) Compounds	Grab	Q			Q
Radiation	24hr Composite	M			Q

D. Laboratories Contributing Results used in this report.

- i) Metropolitan Wastewater Chemistry Laboratory
(EPA Lab Code: CA00380, ELAP Certificate: 1609)
5530 Kiowa Drive
La Mesa, CA 91942
(619)668-3212
All results except those listed below.
- ii) Point Loma Wastewater Chemistry Laboratory
(EPA Lab Code: CA01435, ELAP Certificate: 2474)
1902 Gatchell Road
San Diego, CA 92106
(619)221-8765
Process control analyses and wet methods for the plant.
- iii) North City Wastewater Chemistry Laboratory
(EPA Lab Code: CA01436, ELAP Certificate: 2477)
4949 Eastgate Mall
San Diego, CA 92121
(858)824-6009
Process control analyses and wet methods for the plant.
- iv) Metro Biosolids Center Chemistry Laboratory
(EPA Lab Code: CA01437, ELAP Certificate: 2478)
5240 Convoy Street
San Diego, CA 92111
(858)614-5834
Process control analyses and wet methods for the plant.
- v) South Bay Water Reclamation Plant
(EPA Lab Code: CA01460, ELAP Certificate: 2539)
2411 Dairy Mart Road
San Diego, CA 92173
619.428.7349
Process control analyses and wet methods for the plant.
- vi) City of San Diego - Water Quality Laboratory
(EPA Lab Code: CA00080, ELAP Certificate: 1058)
5530 Kiowa Drive
La Mesa, CA 91942
(619)668-3237
Total Organic Carbon in Wastewater
- vii) City of San Diego - Marine Microbiology and Vector Management
(EPA LabCode: CA01393, ELAP Certificate: 2185)
4918 Harbor Drive, Suite 101
San Diego, CA 92106
(619) 758-2311
Microbiology
- viii) City of San Diego – Toxicity Bioassay Laboratory
(EPA Lab Code: CA01302, ELAP Certificate: 1989)
4918 Harbor Drive, Suite 101
San Diego, CA 92106
(619) 758-2347
Bioassays
- ix) Frontier Analytical Laboratory
5172 Hillside Circle
El Dorado Hills, CA 95762
ELAP Certification: 02113CA
Telephone# (916) 934-0900
Dioxins/Furans
- x) Test America
2800 George Washington Way
Richland, WA 99354-1613
CA ELAP Certification: 2425
Telephone# (509) 375-3131
Gross Alpha/Beta Radioactivity

Summary and Overview:

The Wastewater Chemistry Services Section, Metropolitan Wastewater Department, City of San Diego performs most of the NPDES and other permit and process control chemical and physical testing for the City of San Diego E.W. Blom, Pt. Loma Wastewater Treatment Plant (PLWWTP), North City Water Reclamation Plant (NCWRP), South Bay Water Reclamation Plant (SBWRP), and the Metro Biosolids Center (MBC). We also perform the chemical/physical testing of ocean sediment and fish tissue samples for the Ocean monitoring program for the City of San Diego (PLWWTP Ocean Outfall and SBWRP Ocean Outfall) and the International Boundary and Water Commission, International Treatment Plant outfall. We also perform environmental testing for various customers, both internal to the City of San Diego and for other agencies.

The QA/QC activities of the Laboratory are comprehensive and extensive. Of the 37,282 samples received in the Laboratory in 2011, approximately 33% were Quality Control (QC) samples, such as blanks, check samples, standard reference materials, etc. 118 different analyses were performed throughout the year resulting in 262,329 analytical determinations. Of the determinations, 113,016 (~43%) were QC determinations (e.g. blanks, lab. replicates, matrix spikes, surrogates, etc.) used to determine the accuracy, precision, and performance of each analysis and batch.

We have 5 separate laboratory facility locations, each with its own California ELAP (Environmental Laboratory Accreditation Program) certification for the fields of testing required under California regulations. This is a rigorous program involving continuing independent blind performance testing, biannual comprehensive audits, and extensive documentation requirements. Each of the 5 laboratory facilities in the Metropolitan Wastewater (Metro) Department are independently certified and copies of those certifications are included at Attachment 1. California ELAP certifies fields of testing (methods/analytes) only for Water, Wastewater, and Hazardous materials for which methods are published in the Federal Register or specifically approved in regulation by U.S.EPA. Additionally, the Laboratory performs analyses using methods for which certification does not exist, such as ocean sediment and sea water determinations. Those methods have been developed in-house, derived from or in collaboration with other scientific laboratories (e.g. Scripps Institute of Oceanography, Southern California Coastal Water Research Project, et. al.) and have been used extensively in multi-agency EPA and State sponsored studies over the past several years. Many methods of analysis developed for matrices and applications not within ELAP jurisdiction have been adapted from ELAP listed methods. In all cases, we apply generally accepted standards of performance and quality control to methods.

Additionally, the operating division and all Metro Department Laboratories maintained International Standards Organization (ISO) 14001 Environmental Management Systems certification.

Contract laboratories are also required to use only approved methods for which they hold certification for, and/or are approved by the appropriate regulatory agency (e.g. SDRWQCB). Copies of their certifications are included as Attachment 2.

The following report summarizes the QA/QC activities during 2011 and documents the laboratory information and certifications for those laboratories which provided data used in NPDES and other permit monitoring or environmental testing during the year.

Laboratories Contributing Results used in this report.

Laboratory Name	EPA Lab Code	ELAP Cert.#	Address	Phone #	Contribution
Alvarado Wastewater Chemistry Laboratory	CA00380	1609	5530 Kiowa Drive L Mesa, CA 91942	(619)668-3212	All results except those listed below.
Pt. Loma Wastewater Chemistry Laboratory	CA01435	2474	1902 Gatchell Road San Diego, CA 92106	(619)221-8765	Process Control Analyses and wet mehtod for the treatment plant.
North City Wastewater Chemistry Laboratory	CA01436	2477	4949 Eastgate Mall San Diego, CA 92121	(858)824-6009	Process Control Analyses and wet mehtod for the treatment plant.
Metro Biosolids Center Chemistry Laboratory	CA01437	2478	5240 Convoy Street San Diego, CA 92111	(858)614-5834	Process Control Analyses and wet mehtod for the treatment plant.
South Bay Wastewater Chemistry Laboratory	CA00080	2539	2411 Dairy Mart Road San Diego, CA 92173	(619)428-7349	Process Control Analyses and wet mehtod for the treatment plant.
City of San Diego Water Quality Laboratory	CA01393	1058	5530 Kiowa Drive La Mesa, CA 91942	(619)668-3237	Total Organic Carbon in Wastewater
City of San Diego-Marine Microbiology	CA01302	2185	2392 Kincaid Road San Diego, CA 92101	(619)758-2312	Microbiology
City of San Diego Toxicology Laboratory		1989	2392 Kincaid Road San Diego, CA 92101	(619)758-2341	Bioassays
TestAmerica Laboratories, Inc		2425	2800 George Washington Way, Richland, WA 99354	(509)375-3131	Gross Alpha/Beta Radioactivity
TestAmerica Nashville Division		01168CA	2960 Foster Creighton Drive Nashville, TN 37204	(615)756-0177	Herbicides
Frontier Analytical Laboratory		02113CA	5172 Hillsdale Circle El Dorado Hills, CA 95762	(916)934-0900	Dioxin/Furan Wastewater and Solids

Facilities & Scope:

The Wastewater Chemistry Services Section (WCS) comprises five geographically separated laboratories. The Section's main laboratory facilities and headquarters located at the Alvarado Joint Laboratory building in La Mesa and the four satellite wastewater chemistry laboratories located at MWW treatment plants maintain individual California Department of Health Service, Environmental Laboratory Accreditation Program (ELAP) certification in their respective Fields of Testing (FoT). Each laboratory has its own U.S.EPA Lab Code as shown in the following table.

Laboratory Facility	Laboratory	Address	Phone	EPA Lab. Code	ELAP Cert. No.
Alvarado Laboratory	Wastewater Chemistry Laboratory	5530 Kiowa Drive, La Mesa CA 91942	619.668.3215	CA00380	1609
Point Loma Satellite Lab	Pt. Loma Wastewater Chemistry Laboratory	1902 Gatchell Rd., San Diego, CA 92106	619.221.8765	CA01435	2474
North City Water Reclamation Plant Satellite Lab	North City Wastewater Chemistry Laboratory	4949 Eastgate Mall, San Diego, CA 92121	858.824.6009	CA01436	2477
Metro Biosolids Center Satellite Lab	Metro Biosolids Center Wastewater Chemistry Lab	5240 Convoy Street, San Diego, CA 92111	858.614.5834	CA01437	2478
South Bay Water Reclamation Plant Satellite Lab	South Bay Wastewater Chemistry Laboratory	2411 Dairy Mart Rd., San Diego CA 92154	619.428.7349	CA01460	2539

The information presented in this report applies to the Wastewater Chemistry Services Section, including all of the laboratories listed above, unless specified otherwise. The main laboratory at Alvarado is the main office for the WCS and contains the most extensive laboratory facilities of the several laboratories. Along with a variety of process control and wet chemistry analyses, this facility also handles all of the trace metals, pesticides/organics determinations, and other analyses. The satellite laboratories are primarily dedicated to process control, wet chemistry, and other analyses directly related to the support of the operations of the co-located wastewater treatment plant.

The Wastewater Chemistry Services Section performs most of the NPDES and other permit and process control chemical and physical testing for the:

- E.W. Blom, Pt. Loma Wastewater Treatment Plant (PLWWTP), NPDES Permit No. CA0107409/ Order No. R9-2009-0001, including the ocean monitoring program.
- North City Water Reclamation Plant (NCWRP), Order No. 97-03.
- Metro Biosolids Center (MBC), no permit, but monitoring requirements contained in Permit No. R9-2009-0001.
- South Bay Water Reclamation Plant (SBWRP), NPDES Permit No. CA0109045/ Order No. 2006-067.
- Ocean monitoring program for the International Boundary and Water Commission, International Treatment Plant.
- Other environmental testing for various customers, both internal to the City of San Diego and other public agencies.

A small portion of the required monitoring testing sub-contracted out to laboratories certified by ELAP for those analyses, specifically;

- Gross alpha- and Beta radiations are analyzed by Test America Laboratories, Inc., Richland Division
- Herbicides are analyzed by Test America Laboratories, Inc, Nashville Division
- Total organic carbon (TOC) in water are analyzed by the Water Quality Laboratory, City of San Diego, Water Department.
- Dioxin and Furans in solids and wastewater are analyzed by Frontier Analytical Laboratory.

Copies of these laboratories' ELAP certifications are included as Attachment 2. The City of San Diego pays for additional QC samples (replicates, blanks, and spikes) as a routine quality check on contracted laboratory work. This is beyond the usual and customary practices with contract laboratory work.

Ocean monitoring:

While there are no recognized State certifications for laboratory analyses of marine environmental samples (e.g. seawater, sediments, various tissues, etc.), the City of San Diego has been a leader in the development and standardization of analytical methods for determinations in these areas. Many of the methods are novel approaches developed after extensive research and development from other published work (e.g. organo-tin analyses, sediment grain size, etc.) or adaptations of existing EPA methods (e.g. SW 846 Method 8082 for PCB congeners in sediments, etc.). In all of these cases we participate in extensive inter-laboratory calibration studies. Some of the most extensive studies have involved the participation of several public, academic/research, and private laboratories under the umbrella of the Southern California Coastal Water Research Project (SCCWRP). These programs are repeated periodically as part of the Southern California Bight Regional Monitoring/Survey Project. This is a massive sampling and monitoring program participated in by all of the major Publicly Owned Treatment Works (POTWs), California Water Resource Control Boards, and research organizations.

Our laboratory is a reference (referee) laboratory for the NRCC (National Research Council of Canada) CARP-2 Certified Reference Material (CRM) for fish tissue. This was adopted as the standard reference material for QC QA for the Southern California Bight Regional Project. This sample is also used world-wide as a standard reference material. We have worked with NIST to develop a West Coast marine sediment and fish tissue standard reference material (SRM).

QA/QC Activities Summary:

Report for January 1, 2011 - December 31, 2011.

Table of Contents

IX. Appendices	321
A. Terms and Abbreviations used in this Report.....	323
B. Methods of Analysis	325
C. Frequency of Analysis and Type of Sample - 2011.....	334
D. Laboratories Contributing Results used in this report.	336
Summary and Overview:	337
Facilities & Scope:	339
Performance Testing (PT) Studies for 2011:	345
DMRQA (Discharge Monitoring Report – Quality Assurance)	345
The State of California did not conduct a regular DMR-QA study this year; 2011	345
Excerpt from state letter:.....	345
data file transfer format and a scanned PDF of the report to this e-mail.	345
Alvarado Wastewater Chemistry Laboratory	346
North City Chemistry Laboratory	346
Metro Biosolids Center (MBC) Chemistry Laboratory	346
Pt. Loma Wastewater Chemistry Laboratory.....	346
South Bay Wastewater Chemistry Laboratory	346
E. Staff Contributing to this Report.....	347

7

The sample distribution for 2011 is not significantly changed from 2010. 262,329 analytical determinations were made on 37,282 samples received by the Laboratory in 2011(see table A.). Of these 12,176 or 33% were Quality Control (QC) samples. 12.6% were blanks and 20.0% check or reference samples.

⁷ Data counts (metrics) were obtained on March 28, 2012 and do not include analyses that were underway, but incomplete as of that time. All table data is based on samples collected between January 1, 2011 and December 31, 2011. This data summary is comprehensive; includes all laboratory analyses work for all customers, projects, and programs unless otherwise indicated.

Table A. Samples	2011	2011
	Number of Samples	Percent of total samples
Customer/Environmental samples	25,106	67.34%
Quality Control (QC) samples	12,176	32.66%
Total Samples	37,282	100.00%

QC Samples:

Blanks:

FIELD_BLANK	194	0.52%
REAGENT_BLANK	16	0.04%
TRIP BLANK	2	0.01%
METHOD_BLANK	4,501	12.07%
Total Blanks:	4,713	12.64%

Check samples:

External Check samples	4,450	11.94%
Internal Check samples	2,967	7.96%
Spike Check samples	34	0.09%
SRMs (Standard Reference Material)	12	0.03%
Total Check Samples:	7,463	20.02%
Total QC Samples:	12,176	32.66%

High levels of QC are used for laboratory determinations. 43% of the 262,329 determinations were QC (e.g. blanks, lab replicates, matrix spikes, surrogates, etc.). If calculated for the 256,348 customer determinations only, the percentage increases to 44%.

2.3% of total analytical determinations or 0.5% of analytical batches did not meet internal QA review due to a variety of criteria, e.g. unsuccessful calibration, unacceptable QC performance, etc. Samples having analytical determinations that were rejected are reanalyzed, or, if that is not possible, the data is either not reported or reported but flagged as having not met data quality objectives and may not be suitable for compliance determination.

**Distribution of QC in Analyses
2011**

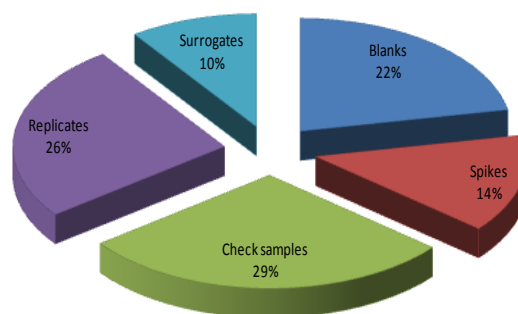
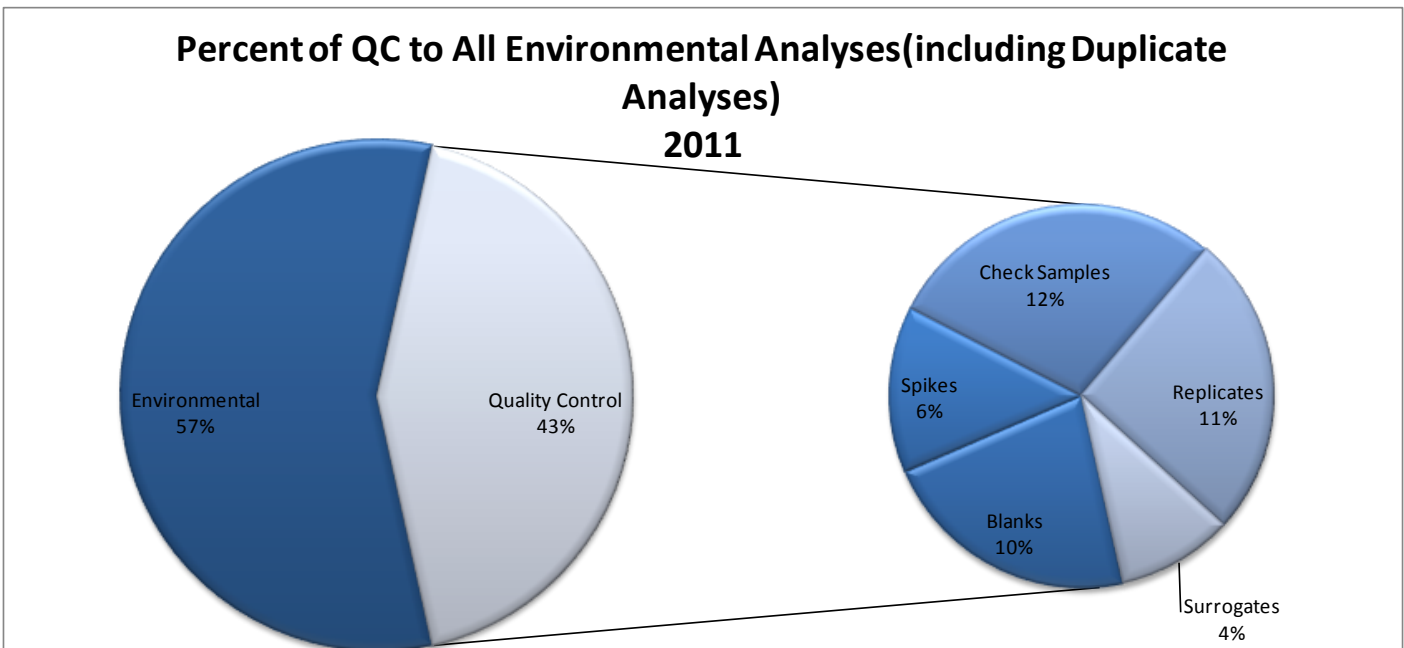

Table A.2. Analyses (results) - 2011

	Number	Percent of total
Total number of analytes/results determined:	262,329	NA
Total results not complete ² :	351	0.1%
No. of results for Customer/ Environmental Samples^{1,3}:	256,348	97.7%
Total number of rejected results:	5,981	2.31%
No. of results for blanks ³ :	24,808	9.5%
No. of results for matrix spikes ³ :	15,902	6.1%
No. of results for Check samples ³ :	32,416	12.4%
No. of results for Replicates ³ :	28,846	11.0%
No. of results for surrogates ³ :	11,044	4.2%
Total QC analyses run³ :	113,016	43.1%
Total in-house analyses completed² :	258,463	



1 – matrix spike, replicates, surrogates are also part of the total for Customer/Environmental samples.

2 – as of March 28, 2012.

3 – percent of QC samples calculated from grand total of 262,329.

NOTE: Analysis, for the purposes of the metrics used in this report generally refer to each analyte determined in each sample in a batch. For example, an analysis (determination) of several metals in a sample (e.g. iron, nickel, lead) would total as 3 analyses in the expression of totals such as those in the Analyses table on the preceding page. This method of calculation has been used for many years and, with batch and method, is useful comparative measure of laboratory performance and is one of the fundamental constants in applying quality control measures.

	No. of Batches	Percent of total
Total number of analytical batches:	14,309	
Total number of rejected analytical batches:	66	0.46%
Incomplete batches (as of March 28, 2011):	0	0.00%

Outside laboratories

A small number of permit required analyses are contracted out, including gross alpha- & Beta- radiation, and Total Organic Carbon in wastewater as summarized below. Herbicides analysis contracted to Test America Laboratory.

Results from sub-contracted laboratory		
Laboratory	Analytes	% of Total in-house Analytes
Test America	338	0.13%
Frontier Labs	3079	1.19%
Water Quality, City of San Diego	74	0.03%
Total sub-contracted laboratory results:	3,491	1.35%

QA Plan:

The Quality Assurance Plan was updated in September 2011.

Performance Testing (PT) Studies for 2011:

The Wastewater Chemistry Laboratories participates in required ELAP and U.S.EPA PT studies throughout the year. We participated in 9 PT studies in 2011. Each of our geographically separated laboratory facilities participated individually (as required by ELAP). All PT studies were purchased from ERA and were successfully completed. When results submitted were determined to be outside of study acceptance limits the laboratory reviewed internal protocols, modified procedures were necessary and participated in a subsequent study for the analytes in question. A PT study was completed with satisfactory results for all analytes by in-house chemistry laboratories.

The results of the Laboratory PT studies for 2011 are summarized in the following tables.

DMRQA (Discharge Monitoring Report – Quality Assurance)

The State of California did not conduct a regular DMR-QA study this year; 2011

Excerpt from state letter:

-----Original message-----

From: Bill Ray <bray@waterboards.ca.gov>

To: "Meyer, Steve" <SMeyer@sandiego.gov>

Sent: Fri, Mar 4, 2011 23:09:36 GMT +00:00

Subject: Re: Out of Office: DMR-QA Waiver information and participation.

Thank you for the information.

The State is not conducting a regular DMR-QA study this year. Please perform those PT samples your in-house lab needs for Certification purposes and instruct all of your contract labs to do the same. Both in-house and contract labs need to tell their respective

PT providers to submit the information to the State Board. The preferred method is electronically in the form of the standard EPA data file transfer format and a scanned PDF of the report to this e-mail.

Alvarado Wastewater Chemistry Laboratory: See attachment 5 for copy of reports.

ERA Study	Number of Analytes	Number of Acceptable results	Success Rate (%)
SOIL-74	155	153	99%
SOIL-75	43	43	100%
WP-193	63	61	97%
WP-194	60	59	98%
WP-195	4	4	100%
WP-196	1	1	100%
WP-197	31	31	98%
WP-198	1	1	100%
WP-199	2	2	100%
Total analytes:	360	Overall:	98.6%

North City Chemistry Laboratory: See attachment 6 for copy of reports.

ERA Study	Number of Analytes	Number of Acceptable results	Success Rate (%)
WP-195	14	14	100%
Total analytes:	14	Overall:	100%

Metro Biosolids Center (MBC) Chemistry Laboratory: See attachment 7 for copy of reports.

ERA Study	Number of Analytes	Number of Acceptable results	Success Rate (%)
WP-196	9	9	100%
Total analytes:	9	Overall:	100%

Pt. Loma Wastewater Chemistry Laboratory: See attachment 8 for copy of reports.

ERA Study	Number of Analytes	Number of Acceptable results	Success Rate (%)
WP-193	15	14	100%
WP-198	1	1	100%
Total analytes:	16	Overall:	100%

South Bay Wastewater Chemistry Laboratory: See attachment 9 for copy of reports.

ERA Study	Number of Analytes	Number of Acceptable results	Success Rate (%)
WP-194	14	14	100%
WP-195	1	1	100%
WP-199	1	1	100%
Total analytes:	16	Overall:	100%

E. Staff Contributing to this Report

Staff Contributing to this Report in 2011

Initials	ID	First Name	Last Name	Signature
BOA	BOA	Ben	Andoh	<i>Benjamin Andoh</i>
TB	TSB	Tan	Bao	<i>Tan Bao</i>
VB	VEB	Virginia	Basilan	<i>VB</i>
EB	BTX	Enrique	Blanco	<i>Enrique Blanco</i>
BGB	N8B	Brent	Bowman	<i>Brent Bowman</i>
TB	TMB	Tom	Burger	<i>Tom B. Burger</i>
LC	UEC	Laura	Carr	<i>Laura Carr</i>
JC	G3C	Jose	Castro	<i>Jose Castro</i>
JCM	U8C	Jacqueline	Cazares-Medina	<i>Jacqueline Cazares Medina</i>
NC	NLC	Nancy	Coglan	<i>Nancy Coglan</i>
MC	M5C	Maricela	Coronel	<i>Maricela Coronel</i>
JCM	G8C	Jerry	Czajkowski	<i>Jerry Czajkowski</i>
KD	KOD	Ken	Dang	<i>Ken Dang</i>
AMD	ADONLON	Angela	Donlon	<i>Angela Donlon</i>
ACD	AD4	Angelica	Duran	<i>Angelica Duran</i>
JTF	JRF	Jeff	Findley	<i>Jeff Findley</i>
EFITZ	EFITZGERALD	Erica	Fitzgerald	<i>Erica Fitzgerald</i>
KG	KG3	Kenneth	Genz	<i>KG</i>
RJ	RCJ	Ron	Jardine	<i>Ron Jardine</i>
LK	LNK	Lee	King	<i>Lee King</i>
VK	VK4	Vesselka	Kozarev	<i>V. Kozarev</i>
EL	EVL	Estela	Lanez	<i>Estela Lanez</i>
WL	WL7	Wendy	Lucero	<i>WL</i>
AM	M5U	Armando	Martinez	<i>Armando Martinez</i>
FM	YBM	Fernando	Martinez	<i>Fernando Martinez</i>
CGM	M4M	Connie	Mata	<i>Connie Mata</i>
FML	IZM	Francisco	Meza	<i>Francisco Meza</i>
JM	G7M	Jeff	McAnally	<i>Jeff McAnally</i>
AM	AM9	Alejandra	Molloy	<i>Alejandra Molloy</i>
JN	IEN	Jesus	Nieto	<i>Jesus Nieto</i>
MN	MGZ	Maria	Noller	<i>Maria Noller</i>
LP	LJP	Lorena	Pantoja	<i>Lorena Pantoja</i>
PP	PPARRA	Paola	Parra	<i>Paola Parra</i>
LP	LXP	Leonard	Przybylo	<i>Leonard Przybylo</i>
CAQ	CQ5	Corinna	Quinata	<i>Corinna Quinata</i>
KR	KRV	Keith	Ruehrwein	<i>Keith Ruehrwein</i>
RS	NDS	Robert	Sandoval	<i>Robert Sandoval</i>
VS	VS7	Victoria	Santibanez	<i>Victoria Santibanez</i>
DWS	DXS	David	Schlickman	<i>David Schlickman</i>
GS	GTS	Greg	Schlimme	<i>Greg Schlimme</i>
GLS	HIR	Gloria	Siqueiros	<i>Gloria Siqueiros</i>
MRS	MWS	Michael	Stewart	<i>Michael Stewart</i>
MIS	S49	Margot	Szeterlak	<i>Margot Szeterlak</i>
SV	SCV	Sandra	Valenzuela	<i>Sandra Valenzuela</i>
JW	AIW	Julie	Webb	<i>Julie Webb</i>
KLW	KLW	Kristof	Witczak	<i>Kristof Witczak</i>

Figure 1. Chemistry Laboratory Organization Chart.

Metropolitan Wastewater Department
 Environmental Monitoring and Technical Services Division
Wastewater Chemistry Laboratory

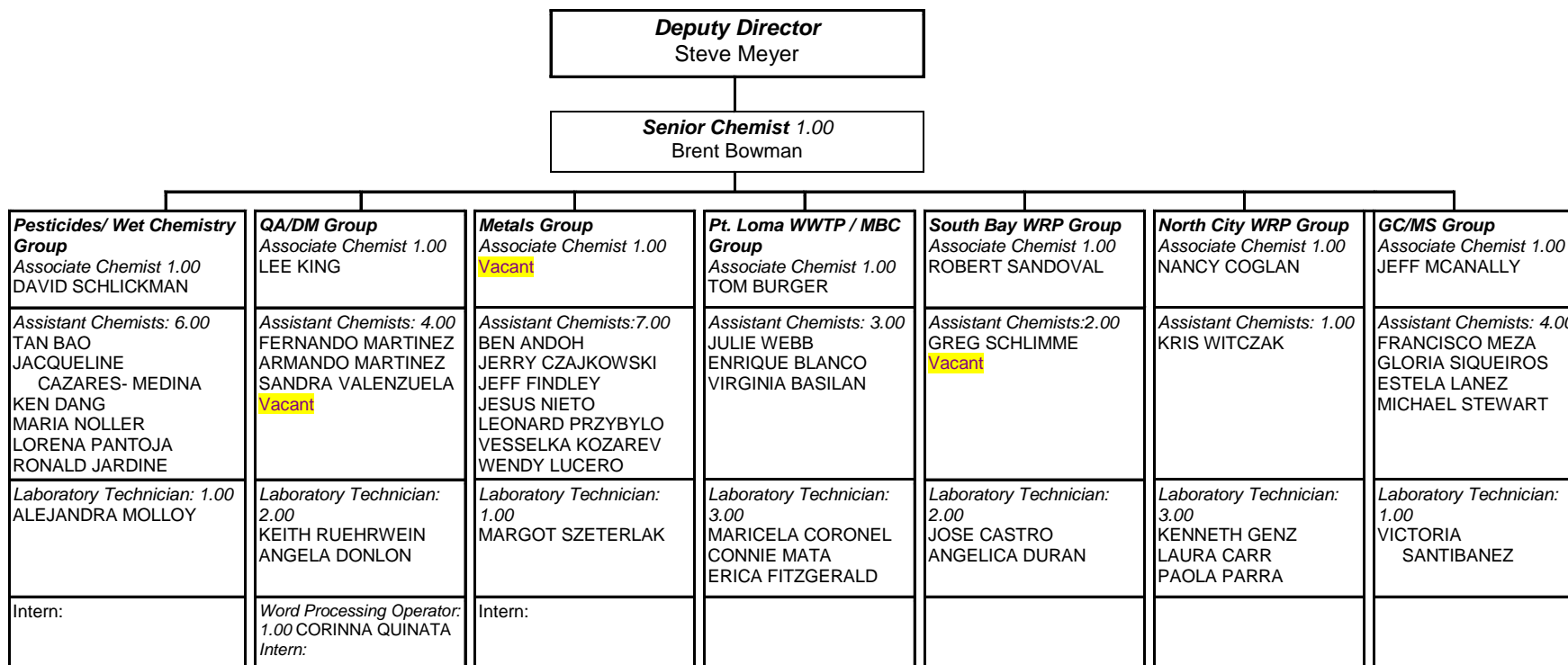

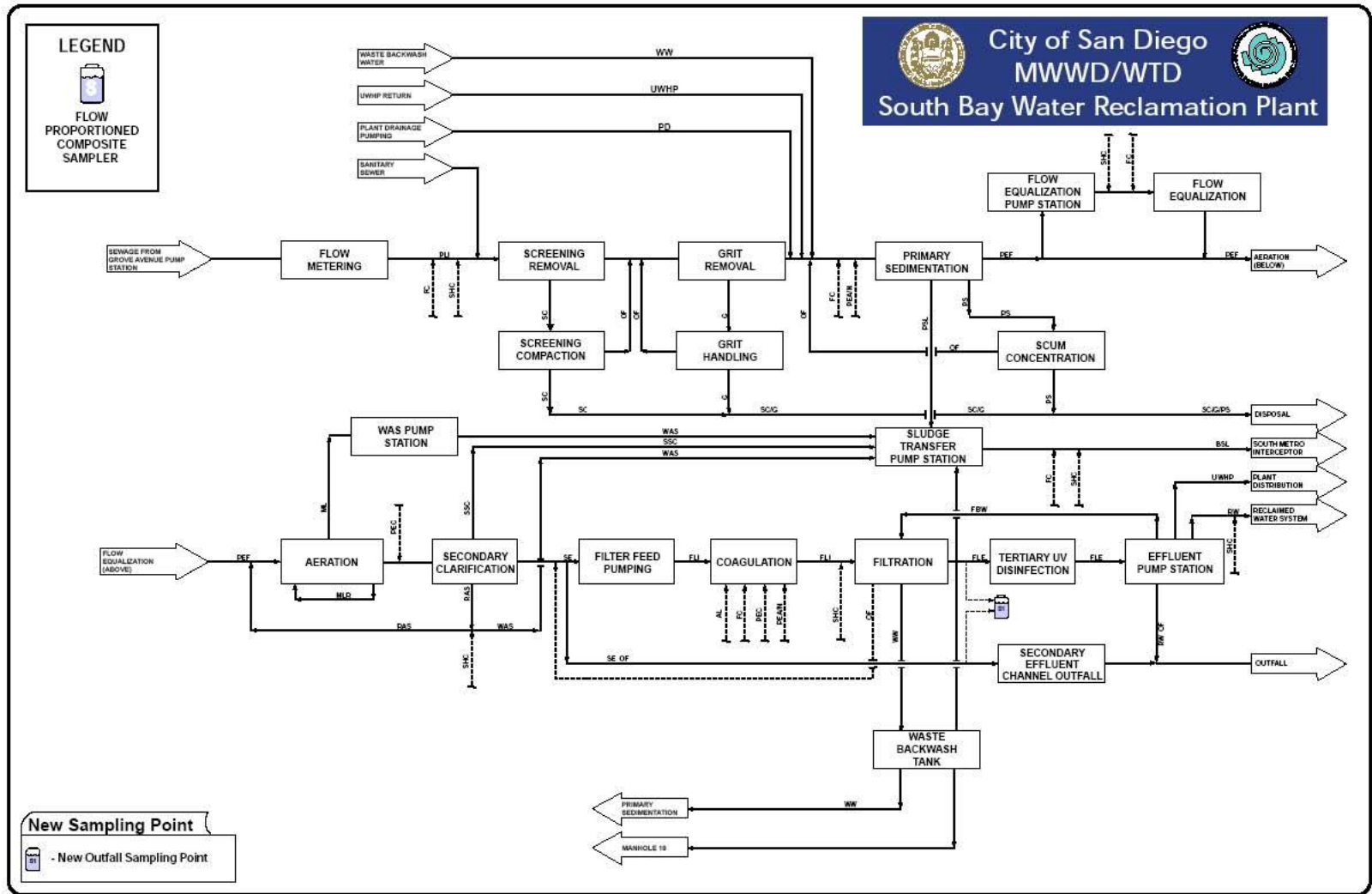

Figure 1 - New Effluent to Ocean Outfall Sample Point

South Bay Water Reclamation Plant
Effluent to Ocean Outfall Sampling System
June 2007

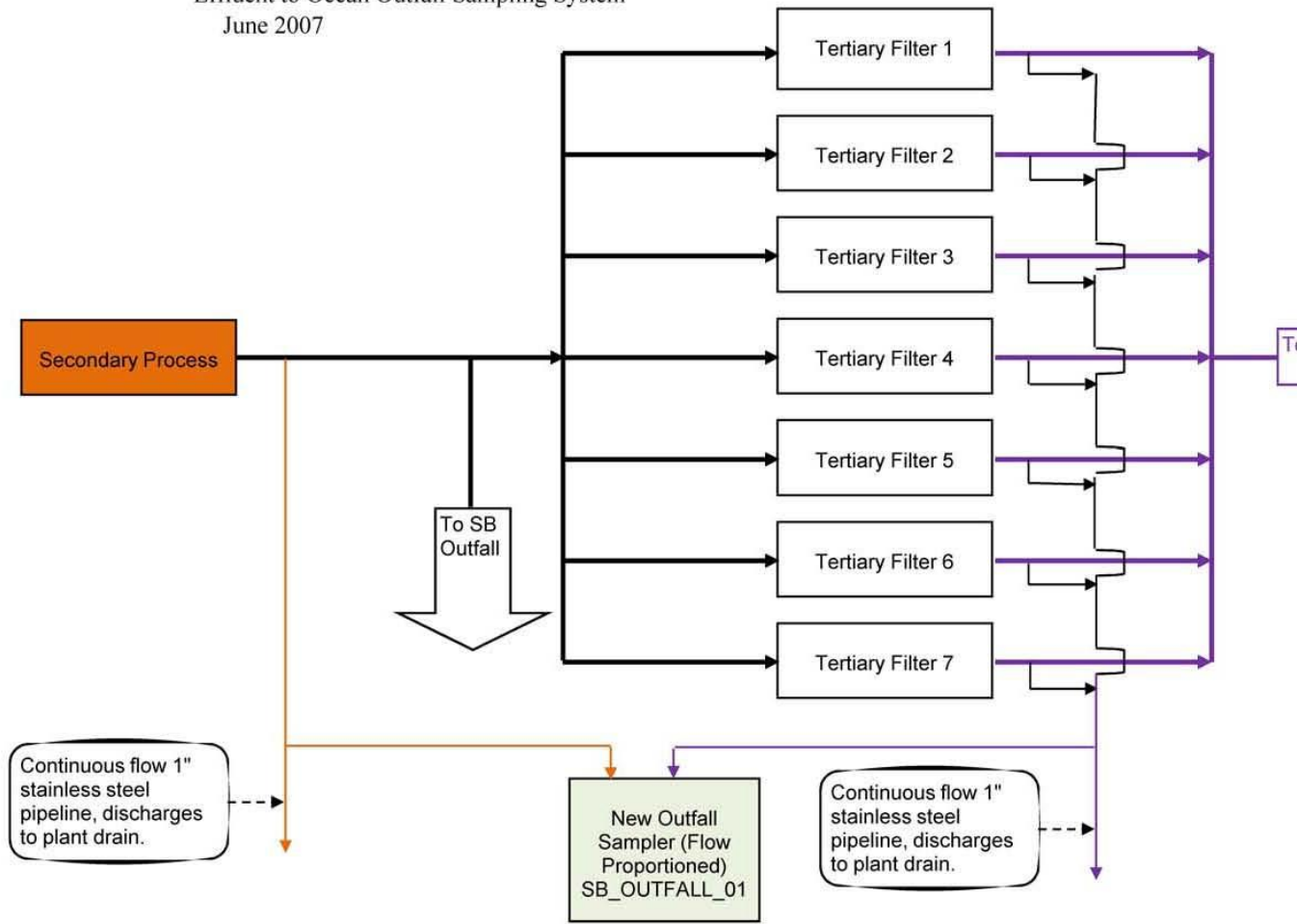

Figure 2 - Detail of Effluent Sampling System