



CENTRAL VILLAGE SPECIFIC PLAN

Otay Mesa Community, San Diego, California



CENTRAL VILLAGE SPECIFIC PLAN

Otay Mesa Community, San Diego, California

Acknowledgements:

Planning Department

Jeff Murphy, Director
Tom Tomlinson, Assistant Director
Tait Galloway, Principal Planner
Lara Gates, Com. Plan Update Project Planner
Bobby Mordenti, Associate Planner

Development Services Department

Robert Vacchi, Director
Kerry Santoro, Deputy Director
Anna McPherson, Senior Planner
John S. Fisher, Development Project Manager
Paul Godwin, Development Project Manager
Jim Lundquist, Associate Engineer – Traffic
Ann French Gonsalves, Senior Traffic Engineer

Prepared by:



T&B Planning, Inc.
3665 Ruffin Road, Suite 208
San Diego, CA 92123

In Consultation With:



**Wimmer Yamada
and Caughey**

**M.W. STEELE
GROUP, INC.**
ARCHITECTURE | PLANNING

**M.W. Steele
Group**



**Project Design
Consultants**



**Chen Ryan
Associates**

Approved by the San Diego City Council April 4, 2017
Ordinance No. 20812

CENTRAL VILLAGE SPECIFIC PLAN

Amendment	Date Approved by Planning Commission	Resolution Number	Date Adopted by City Council	Resolution/Ordinance Number
Central Village Specific Plan Adopted	February 23, 2017	4842-PC	April 4, 2017	R-311019 O-20812

TABLE OF CONTENTS

<u>SECTION</u>	<u>PAGE</u>
1.0 Introduction and Setting	1-1
1.1 Specific Plan Overview	1-1
1.2 Vision for the Central Village	1-1
1.3 Location and Access	1-2
1.4 Relationship to the City of San Diego General Plan and Otay Mesa Community Plan	1-2
1.5 Public Participation	1-5
1.6 Specific Plan Objectives	1-6
1.7 Specific Plan Organization	1-11
1.8 How to Use the Specific Plan	1-11
1.8.1 Authority and Requirements	1-11
1.8.2 Standards and Criteria for Approval	1-13
1.9 Environmental Review	1-14
1.10 Setting	1-14
1.10.1 Site Characteristics.....	1-14
1.10.2 Existing General Plan Land Use Designations	1-14
1.10.3 Existing Infrastructure and Utilities	1-17
1.10.3.1 Roadways.....	1-17
1.10.3.2 Water and Sewer.....	1-18
1.10.3.3 Storm Drainage.....	1-18
1.10.3.4 Solid Waste Management	1-18
2.0 Central Village Land Use Design Standards and Policies.....	2.1-1
2.1 Purpose	2.1-1
2.1.1 Introduction	2.1-1
2.1.2 Definition of Terms	2.1-1
2.1.3 Applicability	2.1-1
2.2 Land Use Element	2.2-1
2.2.1 Central Village Land Use Plan	2.2-1
2.2.2 Land Use Design Standards.....	2.2-2
2.3 Mobility Element.....	2.3-1
2.3.1 Vehicular Mobility Design Standards.....	2.3-1
2.3.1.1 Airway Road.....	2.3-1
2.3.1.2 Cactus Road	2.3-9
2.3.1.3 Heritage Road	2.3-10
2.3.1.4 Green Streets.....	2.3-10
2.3.1.5 Village Entry Streets.....	2.3-11
2.3.1.6 Residential Collectors	2.3-12
2.3.1.7 Private Internal Roadways.....	2.3-12
2.3.1.8 Private Alley	2.3-12
2.3.2 Alternative Transportation Design Standards and Policies	2.3-13
2.3.2.1 Public Transit	2.3-13
2.3.2.2 Bicycle Facilities	2.3-14



<u>SECTION</u>	<u>PAGE</u>
2.3.2.3 Pedestrian Connections	2.3-17
2.4 Parks and Open Space Element	2.4-1
2.4.1 Parks.....	2.4-1
2.4.1.1 Public Parks Overview.....	2.4-1
2.4.1.2 Parks Standards and Policies	2.4-5
A. General Park Design Standards and Policies	2.4-5
B. Village Park Policies	2.4-6
C. Village Central Park Policies	2.4-7
D. Vista Park Policies.....	2.4-7
E. Trails Park Policies	2.4-9
2.4.2 Open Space	2.4-10
2.4.2.1 Open Space Design Standards	2.4-10
2.5 Urban Design Element	2.5-1
2.5.1 Design Principles.....	2.5-1
2.5.1.1 Activity Nodes and Gateways	2.5-1
2.5.1.2 Open Space Connections and View Corridors	2.5-2
2.5.1.3 Gathering Spaces and Interior Courts.....	2.5-2
2.5.1.4 Clear and Interconnected Circulation.....	2.5-11
2.5.1.5 Parking Internal to Block.....	2.5-13
2.5.1.6 Landscaped Buffers as Screening.....	2.5-17
2.5.1.7 Positive Frontage and Connecting Land Use Interfaces	2.5-20
2.5.2 Architectural Design	2.5-25
2.5.2.1 Building Orientation.....	2.5-25
2.5.2.2 Building Form, Massing, and Articulation.....	2.5-26
2.5.2.3 Building Frontage Types	2.5-31
2.5.2.4 Building Access.....	2.5-31
2.5.2.5 Building Materials and Colors.....	2.5-32
2.5.3 Landscape Design.....	2.5-33
2.5.3.1 Plant Palette.....	2.5-33
2.5.3.2 Streetscape Design	2.5-34
A. General Streetscape Design	2.5-45
B. Airway Road Streetscape	2.5-46
C. Cactus Road Streetscape.....	2.5-47
D. Heritage Road Streetscape.....	2.5-49
E. Green Streets Streetscape	2.5-49
F. Village Entries Streetscape.....	2.5-52
G. Residential Collectors Streetscape.....	2.5-53
H. Private Internal Roadways Streetscape	2.5-54
2.5.3.3 Entries and Monumentation	2.5-55
A. Major Entry Monuments.....	2.5-59
B. Project Identity Marker	2.5-59
C. Specific Identity Marker	2.5-60
D. Village Core Intersection Monument.....	2.5-60
2.5.3.4 Walls and Fencing.....	2.5-62

<u>SECTION</u>	<u>PAGE</u>
A. Masonry Project Theme Wall.....	2.5-62
B. Noise Attenuation Wall.....	2.5-63
C. Solid View Wall.....	2.5-64
D. Partial View Wall.....	2.5-65
E. View Wall.....	2.5-65
F. Trail and Open Space Fencing.....	2.5-67
G. General Wall and Fencing Standards.....	2.5-67
2.5.3.5 Brush Management Zones.....	2.5-68
2.5.3.6 Slope Plantings.....	2.5-68
A. Erosion Control Methods.....	2.5-68
B. Natural Slopes.....	2.5-69
C. Slope Maintenance.....	2.5-69
2.5.3.7 Lighting.....	2.5-69
2.5.3.8 Irrigation and Water Conservation.....	2.5-71
2.5.3.9 Landscape Maintenance.....	2.5-72
2.6 Infrastructure Element.....	2.6-1
2.6.1 Water and Sewer.....	2.6-1
2.6.1.1 Water and Irrigation.....	2.6-1
2.6.1.2 Sewer.....	2.6-1
2.6.1.3 Water and Sewer Design Standards.....	2.6-2
2.6.2 Drainage.....	2.6-7
2.6.2.1 Drainage Design Standards.....	2.6-8
3.0 Central Village Specific Plan Implementation.....	3-1
3.1 Purpose.....	3-1
3.2 Severability.....	3-1
3.3 Administration.....	3-1
3.4 Central Village Zoning.....	3-2
3.4.1 Planning Districts.....	3-2
3.4.2 Allowable Uses.....	3-5
3.4.3 Development Regulations.....	3-5
3.5 Construction and Development Permits.....	3-11
3.6 Transfer of Dwelling Units.....	3-12
3.7 Transfer of Commercial Square Footage.....	3-13
3.8 Minor Modifications.....	3-15
3.9 Formal Amendments.....	3-17
3.10 Phasing.....	3-18
3.11 Maintenance.....	3-21
4.0 General Plan Consistency.....	4-1
4.1 General Plan Consistency Overview.....	4-1
4.1.1 San Diego General Plan.....	4-1
4.1.2 Otay Mesa Community Plan.....	4-15



<u>FIGURE NAME AND NUMBER</u>	<u>PAGE</u>
Figure 1-1 Regional Map	1-3
Figure 1-2 Vicinity Map	1-4
Figure 1-3 Otay Mesa Community Plan Vision Map	1-7
Figure 1-4 Design Concept	1-9
Figure 1-5 Otay Mesa Community Plan Land Use Map	1-15
Figure 2.2-1 Specific Plan Land Use Plan.....	2.2-3
Figure 2.3-1 Vehicular Mobility Plan.....	2.3-3
Figure 2.3-2 Street Cross-Sections (1 of 2).....	2.3-5
Figure 2.3-3 Street Cross-Sections (2 of 2).....	2.3-7
Figure 2.3-4 Alternative Transportation Plan	2.3-15
Figure 2.3-5 Conceptual Pedestrian Node Plan	2.3-19
Figure 2.3-6 Conceptual Trellis Elevation.....	2.3-19
Figure 2.3-7 Trailhead Signage Concept	2.3-22
Figure 2.4-1 Parks and Open Space Plan.....	2.4-3
Figure 2.4-2 Village Park Conceptual Design	2.4-6
Figure 2.4-3 Village Central Park Conceptual Design	2.4-8
Figure 2.4-4 Vista Park Conceptual Design	2.4-8
Figure 2.4-5 Trails Park Conceptual Design.....	2.4-9
Figure 2.4-6 Multiple Habitat Planning Areas Surrounding Central Village.....	2.4-11
Figure 2.5-1 Design Principals Key Map.....	2.5-3
Figure 2.5-2 Activity Node and Gateway Intersection at Heritage Road and Airway Road.....	2.5-5
Figure 2.5-3 Mixed Use Development Clustered Around Gateway Intersection	2.5-6
Figure 2.5-4 Conceptual Pedestrian Plaza Design.....	2.5-7
Figure 2.5-5 Mixed Use Development Adjacent To Park and Canyon Open Space	2.5-8
Figure 2.5-6 Multi-Family Residential Development with Gathering Spaces	2.5-9
Figure 2.5-7 Typical Paseo Between Residential Buildings.....	2.5-10
Figure 2.5-8 Townhomes with Integral Paseo and Pedestrian Network	2.5-12
Figure 2.5-9 Parking Internal To Mixed Use Development.....	2.5-14
Figure 2.5-10 Typical Landscape Condition to Screen Street Views to Parking.....	2.5-15
Figure 2.5-11 Typical Pedestrian Path Connecting Parking with Commercial Uses	2.5-16
Figure 2.5-12 Conceptual Parking Design	2.5-17
Figure 2.5-13 Residential Development Adjacent To Airway Road	2.5-18
Figure 2.5-14 Residential Development Adjacent To Cactus Road.....	2.5-19
Figure 2.5-15 Community Facilities Concept Design.....	2.5-21
Figure 2.5-16 Residential Development Adjacent To Public Park.....	2.5-22
Figure 2.5-17 Residential Development Along Main Street	2.5-23
Figure 2.5-18 Frontage Elements on Mixed Use Development.....	2.5-24
Figure 2.5-19 Typical Characteristics of Desired Building Orientation	2.5-25
Figure 2.5-20 Building Scale	2.5-27
Figure 2.5-21 Building Massing	2.5-27
Figure 2.5-22 Building Articulation	2.5-28
Figure 2.5-23 Plant Palette (Page 1 Of 2).....	2.5-41

<u>FIGURE NAME AND NUMBER</u>	<u>PAGE</u>
Figure 2.5-24 Plant Palette (Page 2 Of 2).....	2.5-43
Figure 2.5-25 Airway Road Streetscape- 6-Lane Primary Arterial	2.5-46
Figure 2.5-26 Airway Road Streetscape – 6-Lane Major.....	2.5-47
Figure 2.5-27 Cactus Road Streetscape (South Of Airway Road).....	2.5-48
Figure 2.5-28 Cactus Road Streetscape (North Of Airway Road).....	2.5-48
Figure 2.5-29 Heritage Road Streetscape	2.5-50
Figure 2.5-30 Conceptual Mural at Bulb-Outs Design	2.5-50
Figure 2.5-31 Conceptual Roundabout Design	2.5-51
Figure 2.5-32 Green Street Streetscape.....	2.5-52
Figure 2.5-33 Village Entry Streetscape	2.5-53
Figure 2.5-34 Residential Collectors Streetscape	2.5-54
Figure 2.5-35 Private Internal Roadways Streetscape (With and Without Optional Parking).....	2.5-55
Figure 2.5-36 Monument Location Map	2.5-57
Figure 2.5-37 Major Entry Monument.....	2.5-59
Figure 2.5-38 Project Identity Marker.....	2.5-60
Figure 2.5-39 Specific Identity Marker.....	2.5-61
Figure 2.5-40 Village Core Intersection Monument.....	2.5-61
Figure 2.5-41 Masonry Project Theme Wall	2.5-63
Figure 2.5-42 Noise Attenuation Wall.....	2.5-64
Figure 2.5-43 Solid View Wall	2.5-65
Figure 2.5-44 Partial View Wall.....	2.5-66
Figure 2.5-45 View Wall	2.5-66
Figure 2.5-46 Trail and Open Space Fencing.....	2.5-67
Figure 2.5-47 Brush Management Zones.....	2.5-68
Figure 2.6-1 Conceptual Water Plan	2.6-3
Figure 2.6-2 Conceptual Sewer Plan	2.6-5
Figure 2.6-3 Conceptual Drainage Plan.....	2.6-9
Figure 3-1 Planning Districts Map	3-3



<u>TABLE NAME AND NUMBER</u>	<u>PAGE</u>
Table 2.2-1 Central Village Specific Plan Land Use Abstract.....	2.2-5
Table 2.2-2 Maximum Permitted Commercial Area	2.2-7
Table 2.3-1 Central Village Roadway Improvement Standards	2.3-2
Table 2.5-1 Building Frontage Types.....	2.5-29
Table 2.5-2 Village-Wide Plant Palette	2.5-35
Table 3-1 Central Village Specific Plan Use Supplemental Regulations.....	3-6
Table 3-2 Central Village Supplemental Development Regulations	3-9
Table 3-3 Central Village Park Assumptions	3-19
Table 3-4 Central Village On-Site Park Development Requirements – Dwelling Unit Thresholds.....	3-19
Table 3-5 Maintenance Responsibilities	3-21
Table 4-1 San Diego General Plan Consistency.....	4-1
Table 4-2 Otay Mesa Community Plan Consistency	4-15

1.0 INTRODUCTION AND SETTING

1.1 SPECIFIC PLAN OVERVIEW

The 229.2-acre CENTRAL VILLAGE Specific Plan is a mixed use village located in the central portion of the City of San Diego’s Otay Mesa Community. The CENTRAL VILLAGE provides a pedestrian-friendly, inviting, and attractive environment with a unique sense of place that is designed to embrace the “Village Concept” outlined in the Otay Mesa Community Plan and City of San Diego General Plan.

The Otay Mesa Community Plan designates the CENTRAL VILLAGE for “neighborhood village” and “community village” land uses. These land use categories call for a range of housing choices conveniently located near community-serving commercial uses, civic uses, and parks. Consistent with the Community Plan’s vision for this area, the CENTRAL VILLAGE is a walkable, mixed use village that integrates residential, commercial, civic, and recreational uses in ways that create a vibrant living experience.

1.2 VISION FOR THE CENTRAL VILLAGE

The vision of the CENTRAL VILLAGE is a compact, pedestrian-oriented village anchored by two “pulse points” that define primary gateways into the mesa. The activity nodes located at the Cactus Road/Airway Road and Heritage Road/Airway Road intersections establish a sense of arrival from the east and west. A grid system of streets forms blocks that support walkability and enhanced connectivity throughout the village. Residential homes are integrated either horizontally or vertically with commercial land uses near the two main gateways on Airway Road, which create a vibrant and memorable mixed use experience leading into the village.

Streets are designed as active public realms by orienting development along the primary roadways, mixed use areas, and parks. Positive frontage is also encouraged with tucked away parking that is internal to the block wherever possible. A trails and paseo system connects key destinations throughout the CENTRAL VILLAGE and provides access to “view corridors” of Tijuana, Mexico and open spaces and canyons located along the southern and western edges of the mesa. In addition, CENTRAL VILLAGE is designed to reduce the impacts of potential industrial and residential collocation issues through streetscape, landscape, and building design.

The arrangement, orientation, and design of streets, open spaces, public amenities, and residential and commercial development creates a mixed



“CENTRAL VILLAGE is a walkable, mixed use village that integrates residential, commercial, civic, and recreational uses”



use village purposefully planned to encourage residents to walk or bike to neighborhood parks, shopping, dining, school, and social activities.

1.3 LOCATION AND ACCESS

The CENTRAL VILLAGE Specific Plan area is located in the southern portion of the City of San Diego, within the Otay Mesa Community. As shown on Figure 1-1, *Regional Map*, the CENTRAL VILLAGE is situated immediately south of California State Route 905 (SR-905), 2.4 miles east of Interstate 805 (I-805) and Interstate 5 (I-5), and 0.5 mile north of the United States and Mexico International Border. Specifically, the CENTRAL VILLAGE is bordered by SR-905 and Airway Road to the north, Cactus Road and Continental Road to the east, and Siempre Viva Road to the south, which terminates at Cactus Road (see Figure 1-2, *Vicinity Map*).

1.4 RELATIONSHIP TO THE CITY OF SAN DIEGO GENERAL PLAN AND OTAY MESA COMMUNITY PLAN

The City of San Diego General Plan provides the citywide vision for growth and a comprehensive policy framework to implement that vision. The City's General Plan Land Use Element identifies 55 Community Plans (including the Otay Mesa Community Plan), which provide community scale policy recommendations for specific geographic areas of the City. The Land Use Element identifies the City of Villages strategy as the implementing tool to guide the City's growth within the context of the community planning program. This strategy aims to create mixed use villages throughout the City that are connected by high-quality transit.

The Otay Mesa Community Plan was first adopted by the San Diego City Council in 1981, and was intended to guide development of the area through the year 2000. Its principal goals included annexing portions of Otay Mesa into the City of San Diego, coordinating development of the Otay Mesa Port of Entry, increasing employment opportunities, creating residential communities, and providing amenities for employees and residents. The Community Plan called for residential and supporting commercial development in western Otay Mesa with industrial development and limited commercial uses in the central and eastern portions of the community surrounding Brown Field. Since that time, Otay Mesa's location just north of the U.S. / Mexico border has allowed portions of the community to develop into a thriving bi-national regional center, with several recent major infrastructure upgrades, such as the establishment of State Route 905. Furthermore, since that time, per the goals of the Otay

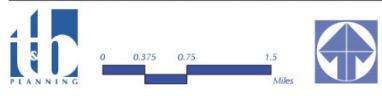

Figure 1-1 Regional Map



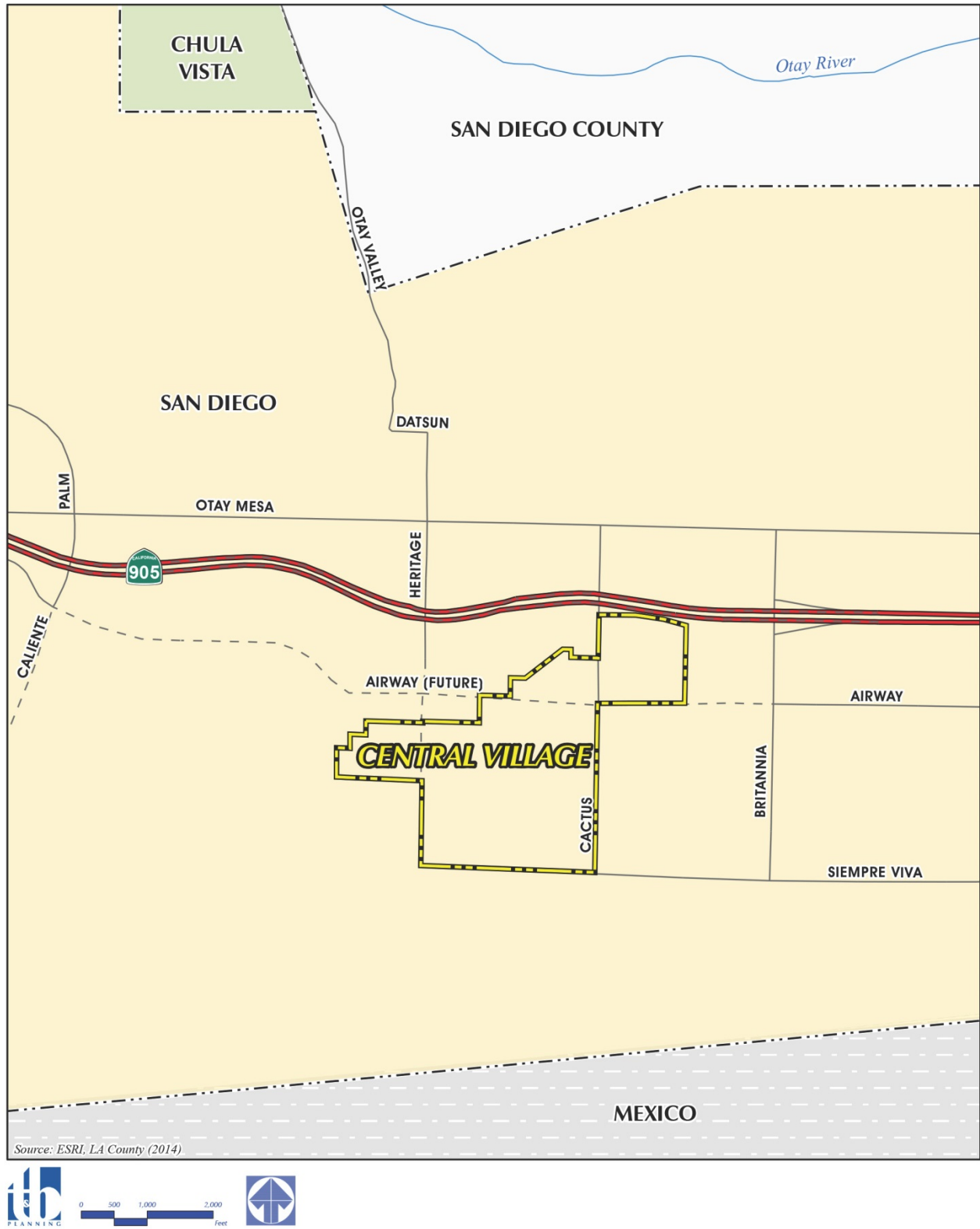

Figure 1-2 Vicinity Map

Mesa Community Plan, portions of Otay Mesa were annexed into the City of San Diego.

In March 2014, the City of San Diego updated the Otay Mesa Community Plan to provide for broad land use themes that seek to establish a bi-national center; provide for economic diversification; enhance and sustain Otay Mesa's industrial capacity; encourage and support international trade; promote the establishment of balanced neighborhoods that integrate a mix of land uses; and identify infrastructure needs, such as transit service. The Community Plan also establishes five distinct Districts that pertain to specific geographic areas (see Figure 1-3, *Otay Mesa Community Plan Vision Map*).

The Otay Mesa Community Plan designates the Southwest District and Central District as the two areas that will implement the City of Villages strategy through a Specific Plan process. The Community Plan foresees these villages as comprising compact, active areas with sustainable and efficient land use patterns that are pedestrian-friendly, transit-oriented, and include a variety of residential, commercial, and civic spaces.

The CENTRAL VILLAGE Specific Plan area encompasses approximately 229.2 acres of the Central District. The Central District is described by the Community Plan as having a village center at the western end of the mesa (the CENTRAL VILLAGE area) that is predominately residential in nature with core areas of mixed uses and public spaces sited along Airway Road. Central to supporting this vision is the ability to facilitate development in the CENTRAL VILLAGE by collaborating with master developers to achieve large scale development that also is viable based on market conditions that may exist at the time of implementation.

The CENTRAL VILLAGE Specific Plan guides the development of a mixed use village by providing site-specific land use design standards and policies. The primary purpose of the CENTRAL VILLAGE Specific Plan is to implement the City of Villages strategy in the Central District.

1.5 PUBLIC PARTICIPATION

The land use and design themes that guided the preparation of the Otay Mesa Community Plan were largely developed through an extensive public outreach process. Public participation included a series of roundtables, Planning Commission workshops, public workshops, and community planning group meetings. Similar to the Otay Mesa Community Plan



preparation process, public outreach played a vital role during preparation of the CENTRAL VILLAGE Specific Plan.

1.6 SPECIFIC PLAN OBJECTIVES

The Otay Mesa Community Plan identifies the vision for the CENTRAL VILLAGE community as:

“...a medium to high density residential community centered along Airway Road, and focused around school and park uses, as well as village-scale retail.”

This CENTRAL VILLAGE Specific Plan implements the CENTRAL VILLAGE community vision through the following objectives, which are conceptually illustrated on Figure 1-4, *Design Concept*:

- ❖ Establish a clear sense of place with two activity nodes located at the village’s entrance from the east (Cactus Road/Airway Road) and west (Heritage Road/Airway Road) along Central Main Street;
- ❖ Locate the school site in an area that is central to the mesa and easily accessible;
- ❖ Connect the school site, neighborhood parks, and the adjacent Grand Park with a boulevard or “green street” that offers a pleasant pedestrian environment;
- ❖ Orient development toward the school site, streets, parks and open space to provide a positive frontage, “eyes on the street,” and an active and pleasant public realm;
- ❖ Provide a range of housing choices and styles to include affordable housing;
- ❖ Focus high density and high intensity uses along Airway Road and near the intersection of Airway Road and Cactus Road;
- ❖ Protect residential uses from nearby industrial areas through landscaped buffers, streetscapes, and building design strategies;
- ❖ Provide a compact, grid network of streets that connects the village to its context and supports internal connectivity and walking;
- ❖ Balance development with the preservation of steep slopes and sensitive natural resources; and
- ❖ Provide pedestrian trails, parkways, and bicycle facilities that link activity nodes with residential areas, public amenities, and open space.

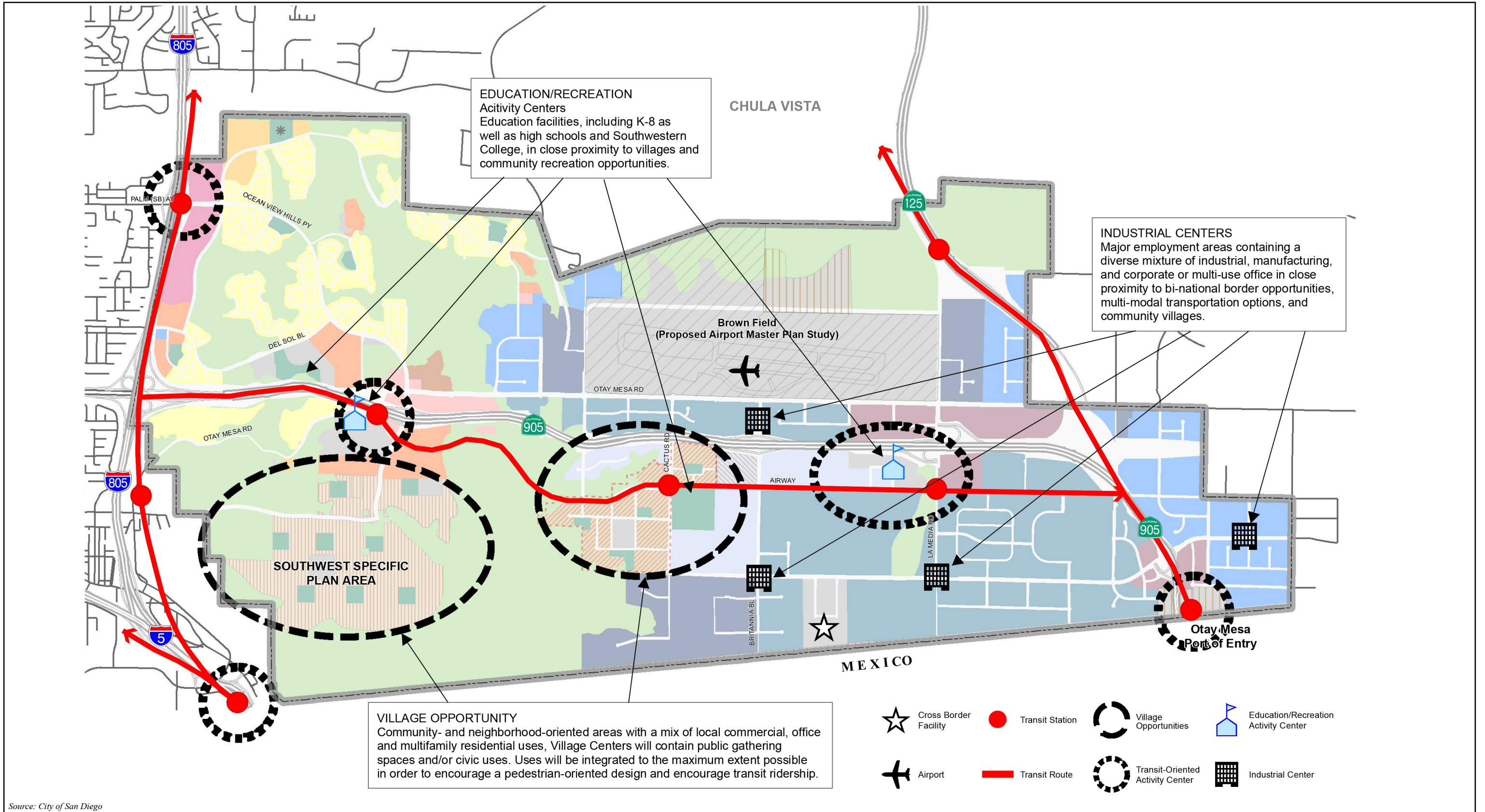

Source: City of San Diego

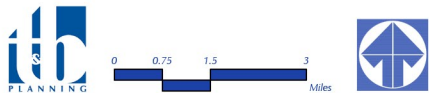

Figure 1-3

OTAY MESA COMMUNITY PLAN VISION MAP



This page intentionally left blank.



- A** GATEWAY/ ACTIVITY NODES
- B** LOOKOUTS & OPEN SPACE CONNECTIONS
- C** PEDESTRIAN PASEOS AND GREENWAYS
- D** DEFINED ENTRANCES & CORNERS
- E** PARKING BEHIND DEVELOPMENT
- F** LANDSCAPE BUFFERS AND SCREENING
- G** CLEAR PATHS & CIRCULATION THAT CONNECTS
- H** POSITIVE FRONTAGE & CONNECTION TO THE VILLAGE
- I** GATHERING SPACES / INTERIOR COURTS

Figure 1-4



This page intentionally left blank.

1.7 SPECIFIC PLAN ORGANIZATION

This CENTRAL VILLAGE Specific Plan is divided into the following four chapters:

Chapter 1, *Introduction and Setting*, provides an overview of the Specific Plan and vision for the CENTRAL VILLAGE; summarizes the relationship between the City’s General Plan, Otay Mesa Community Plan, and the CENTRAL VILLAGE Specific Plan; identifies the Specific Plan objectives; describes the public outreach process and authority of the Specific Plan; and discusses existing land uses and infrastructure.

Chapter 2, *Central Village Land Use Design Standards and Policies*, describes the five development components of this Specific Plan, including: land use; mobility system; parks and open space areas; urban design; and infrastructure improvements. Design Standards and Policies for development within the Specific Plan area are also provided in this chapter.

Chapter 3, *Central Village Specific Plan Implementation*, discusses the policies and processes associated with the implementation of the Specific Plan.

Chapter 4, *General Plan Consistency*, provides the consistency analysis between the Specific Plan and the goals and policies of the City’s General Plan and Otay Mesa Community Plan, as required pursuant to City of San Diego Land Development Code § 122.0107.

1.8 HOW TO USE THE SPECIFIC PLAN

The CENTRAL VILLAGE Specific Plan is a regulatory document that sets forth physical design standards and policies relative to land use designations; building intensity; landscaping; architectural character; vehicular and pedestrian circulation; and other infrastructure improvements such as water, wastewater, and drainage systems. When using this Specific Plan to review future development projects or determine appropriate uses for a site, the applicable zoning regulations of the City’s Land Development Code that are not superseded by the design standards contained in this Specific Plan should also be reviewed to ensure full implementation of this plan. The Specific Plan provisions shall take precedence over the Land Development Code. Where the Specific Plan is silent on a topic, the Land Development Code requirements shall remain in force.

1.8.1 AUTHORITY AND REQUIREMENTS

Pursuant to the California Constitution, the City of San Diego is designated as a Charter City, which authorizes the City of San Diego to have authority of

“A Specific Plan is designed to address site-specific issues, such as building setbacks and visual appearance; project-wide infrastructure systems like circulation and utilities; and public services.”



their municipal affairs. Pursuant to City of San Diego Land Development Code § 122.0107, the City of San Diego has the authority to prepare specific plans of development for any area covered by its General Plan for the purpose of establishing systematic methods of implementing the General Plan. The Otay Mesa Community Plan calls for the preparation of a Specific Plan for the Central District. The General Plan and Community Plan, unlike a Specific Plan, do not show coarse levels of detail for local streets, or specific land uses. A Specific Plan is designed to address site-specific issues, such as building setbacks and visual appearance; project-wide infrastructure systems like circulation and utilities; and public services. While the General Plan examines the entire City and the Community Plan address all of Otay Mesa, this Specific Plan concentrates on the individual development issues of the CENTRAL VILLAGE.

City of San Diego Land Development Code § 122.0107 establishes the authority to adopt a Specific Plan, identify the required contents of a Specific Plan, and mandate consistency with the General Plan. According to City of San Diego Land Development Code § 122.0107:

- (a) *Specific plans adopted on or after January 1, 2000 shall be prepared pursuant to the California Government Code.*
- (b) *The specific plan shall include the required contents listed in California Government Code Section 65451. The required contents shall be formulated into a policy element and a regulatory element. The policy element shall contain detailed land use policies for the area covered by the specific plan and the decision process and permit type for subsequent development proposals that will implement the specific plan. The specific plan shall not establish new decision processes or permit types, but shall use Processes One through Process Five as established in Chapter 11 and the permit types described in Chapter 12. The zoning regulations shall consist of either:*
 - 1. *Applicant of existing base zones of Chapter 13; or*
 - 2. *Proposed base zones that shall be adopted into Chapter 13 as well as applied to the area covered by the specific plan. These zones shall become base zones that could be applied to other property in the City.*
- (c) *Zoning or rezoning to implement the specific plan shall be adopted by ordinance of the City Council.*

The Otay Mesa Community Plan states that the community plan is the blueprint for future development in the community, and is utilized to determine the future level of needs for services and facilities. According to the Otay Mesa Community Plan:

“The Otay Mesa Public Facilities Financing Plan (PFFP) implements this community plan as it identifies the public facilities needed to comply with General Plan standards and the Otay Mesa Community Plan. The PFFP includes a description of public facilities with funding sources, and a schedule of proposed facilities benefit assessments (FBA). The dollar amount of the assessment is based upon the cost of each public facility equitably distributed over a designated area of benefit in the community planning area. Fees are paid on the actual development when permits are issued.”

This Specific Plan provides the essential link between the policies of the City of San Diego General Plan, Otay Mesa Community Plan, and the development expected in the Specific Plan area. By functioning as a regulatory document, the CENTRAL VILLAGE Specific Plan provides a means of implementing and detailing the City’s General Plan and Otay Mesa Community Plan. In this regard, all future development plans and entitlement permits for development in the CENTRAL VILLAGE are required to be consistent with policies and design standards set forth in this document and with all applicable City regulations, which combined, provide flexibility to accommodate changes in the market and the changing needs of the City and community.

“...all future development plans and entitlement permits are required to be consistent with regulations set forth in this document and with all applicable City regulations”

1.8.2 STANDARDS AND CRITERIA FOR APPROVAL

The Otay Mesa Community Plan requires that a Specific Plan be adopted for the CENTRAL VILLAGE portion of the Central District before the City takes site-specific development applications under consideration for the CENTRAL VILLAGE. As required by the Community Plan, an amendment to the Community Plan was adopted in conjunction with the CENTRAL VILLAGE Specific Plan’s approval. A rezone also was adopted to provide consistency with the amended Community Plan Land Use Plan and the CENTRAL VILLAGE Specific Plan.

Chapter 3 of this Specific Plan establishes the procedures and requirements that the City of San Diego will follow when considering implementing development applications within the Specific Plan area. Subsequent discretionary actions may include tract maps; site development permits; grading permits; storm drainage, water, and sewer system approvals; parks and landscaping approvals; and approval and construction of school



facilities. Together, this Specific Plan, the Community Plan Amendment, and Rezone processed concurrently with this document; Addendum No. 1 to the Otay Mesa Community Plan EIR (discussed below); and any pre-implementation requirements that may be identified by the City of San Diego as part of implementing actions that would serve as a companion to this Specific Plan, provide a detailed roadmap for the orderly development of CENTRAL VILLAGE, while taking into account all local goals, objectives, and environmental considerations.

1.9 ENVIRONMENTAL REVIEW

The CENTRAL VILLAGE Specific Plan was required by State law to undergo environmental review in accordance with the California Environmental Quality Act (CEQA). Pursuant to State and local CEQA guidelines, the City of San Diego prepared an Addendum to the Otay Mesa Community Plan Environmental Impact Report (EIR, State Clearinghouse No. 2004651076) to address the potential environmental impacts of the CENTRAL VILLAGE Specific Plan. Prior to the approval of the Specific Plan, the EIR Addendum was considered and certified by the San Diego City Council. Any amendments to this Specific Plan or discretionary approvals required to implement this Specific Plan also are subject to the requirements of CEQA.



Canyons adjacent to CENTRAL VILLAGE.

1.10 SETTING

1.10.1 SITE CHARACTERISTICS

In 2017 when this Specific Plan was prepared, the 229.2-acre property was primarily characterized by large areas of undeveloped land and several scattered buildings and structures associated with agricultural crop production in the southeastern portion of the property. The site is surrounded by the Spring Canyon system to the north, west, and south, which physically separates the area from the Otay Mesa Community Plan’s Southwest Specific Plan Area. Industrial land uses with pockets of undeveloped land are located north, east, and south of the site.

1.10.2 EXISTING GENERAL PLAN LAND USE DESIGNATIONS

Prior to approval of this Specific Plan, the City of San Diego General Plan’s Otay Mesa Community Plan designated the 229.2-acre site for neighborhood village (15-25 du/ac), community village (30-35 du/ac), parks, open space, and institutional land uses. The revised Otay Mesa Community Plan Land Use Map is shown on Figure 1-5, *Otay Mesa Community Plan Land Use Map*).



Existing industrial buildings to the north of CENTRAL VILLAGE.

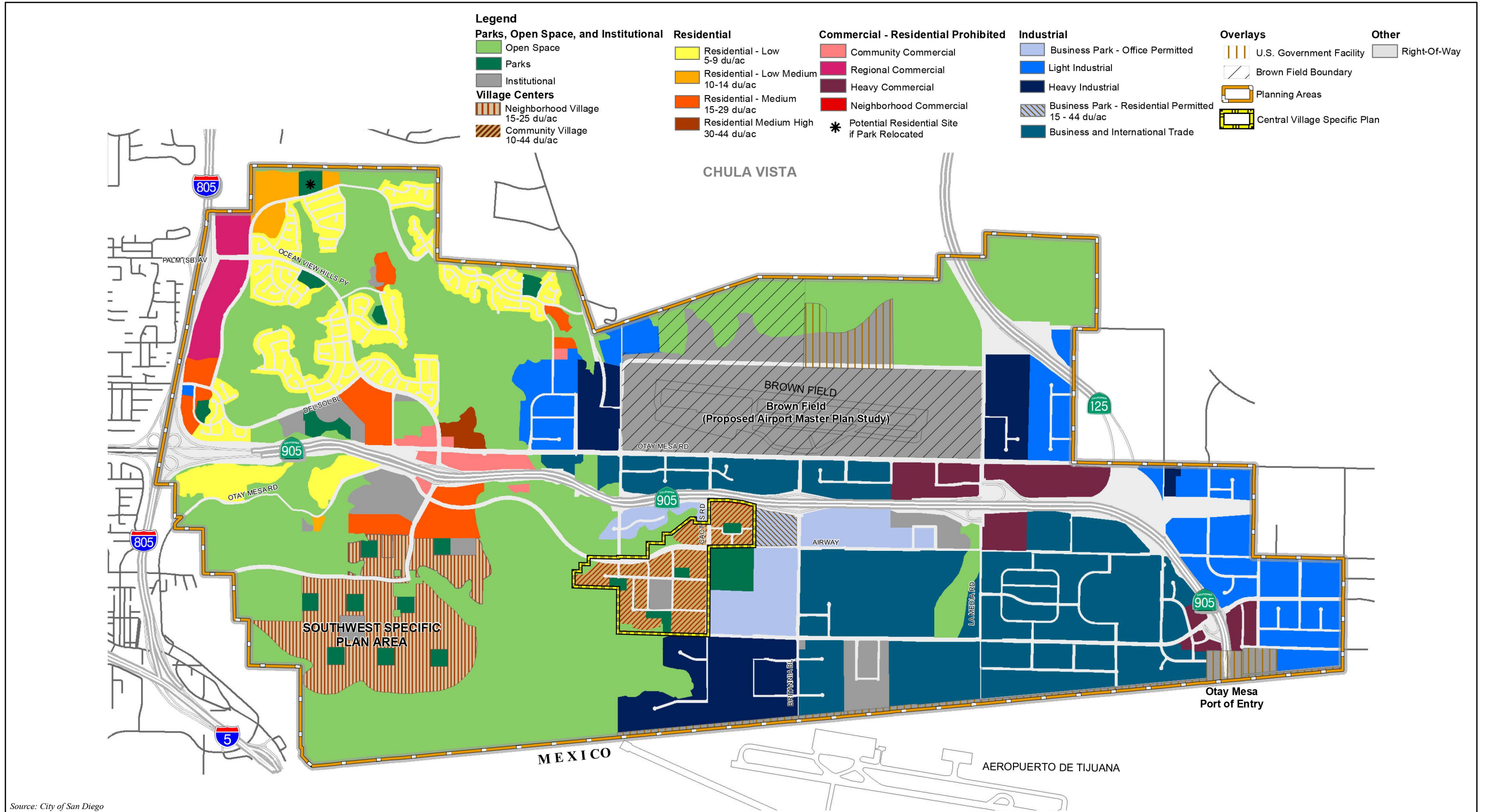

Source: City of San Diego

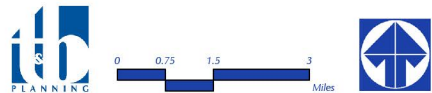

Figure 1-5

OTAY MESA COMMUNITY PLAN LAND USE MAP



This page intentionally left blank.

1.10.3 EXISTING INFRASTRUCTURE AND UTILITIES

Infrastructure and utility systems in the CENTRAL VILLAGE as of 2017 are described below.

1.10.3.1 Roadways

As shown in Figure 2.3-1, *Vehicular Mobility Plan*, the Specific Plan area is bounded by State Route 905 (SR-905) to the north; Cactus Road and Continental Road to the east; and Siempre Viva Road to the south, which dead ends at Cactus Road. Regional access to the Specific Plan area is provided from SR-905 to the north via Britannia Road, with local access afforded by Airway Road, Siempre Viva Road, and Cactus Road. Under 2017 conditions, Airway Road between its terminus at Cactus Road and Britannia Boulevard was partially improved to provide one travel lane in each direction, with no sidewalks or parkways. Between Cactus Road and Continental Road, the travel way along Airway Road is currently 25 feet in width within an existing 40-foot wide right-of-way (ROW). East of Continental Road, the travel way along Airway Road widens to approximately 40 feet within an existing ROW width of 60 feet in width near the intersection with Cactus Road. Cactus Road between Siempre Viva Road and SR-905 was similarly partially improved to provide one travel lane in each direction, with partial improvements to a portion of the eastern edge of the roadway. At the intersection with Siempre Viva Road, Cactus Road is approximately 22 feet in width within a 50-foot ROW. North of the intersection the paved width narrows to 20 feet as it approaches Airway Road within a ROW that varies from 40 to 70 feet in width. North of Airway Road, the Cactus Road travel way is approximately 20 feet wide within a ROW that varies between 40 and 60 feet in width. Continental Road is currently unimproved but approximately 60 feet of the ultimate ROW have been dedicated.

The Otay Mesa Community Plan designates Cactus Road between Siempre Viva and Otay Mesa Road as a 4-Lane Major Arterial. Heritage Road, north of Airway Road, is classified as a 6-Lane Primary Arterial. Within the CENTRAL VILLAGE area, the Otay Mesa Community Plan designates Airway Road as follows:

- Airway Road, west of Heritage Road: 4-Lane Major Arterial;
- Airway Road, between Heritage Road and Cactus Road: 6-Lane Primary Arterial; and
- Airway Road, between Cactus Road and Britannia Boulevard: 6-Lane Major Arterial.



State Route 905 to the north of CENTRAL VILLAGE.



1.10.3.2 Water and Sewer

Water service in the Specific Plan area is provided by two agencies. The Otay Water District provides potable water to the majority of the Specific Plan area (east of Heritage Road) via connections to the existing and planned water mains located in the rights-of-way of Cactus, Airway, Heritage, and Siempre Viva Roads. A small portion of the Specific Plan area (west of Heritage Road) is located within the City of San Diego's water service area; however, as of 2017, there were no existing City of San Diego water mains located in close proximity to the Specific Plan area.

The City of San Diego is the sewer collection system provider for the Specific Plan area. As of 2017, sewer flows generated within the Specific Plan area were conveyed to a pump station located near Cactus Road and Siempre Viva Road. From the pump station, sewer flows are conveyed to a gravity sewer in Otay Mesa Road that connects to the City's Otay Valley Trunk Sewer.

1.10.3.3 Storm Drainage

Historically, the site drains to the northwest and south into the multiple finger canyons surrounding the Specific Plan area. Storm water generated within the portion of the Specific Plan located to the northeast of the Airway Road/Cactus Road intersection drains northwest into a culvert under Cactus Road where it eventually drains into North Canyon.

The site is not located within a FEMA special flood hazard area; however, there may be areas of localized flooding in the canyon and other drainage concentration points surrounding the Specific Plan area.

1.10.3.4 Solid Waste Management

Solid waste collection and disposal service to the Specific Plan area, which proposes multi-family and commercial land uses, is provided through a franchise agreement with a local waste collection agency (Edco Disposal). Solid waste is deposited in the Otay Landfill in Chula Vista and is operated by Otay Landfill, Inc.

2.0 CENTRAL VILLAGE LAND USE DESIGN STANDARDS AND POLICIES

2.1 PURPOSE

2.1.1 INTRODUCTION

This chapter describes the CENTRAL VILLAGE development concept and its five main components: land use; mobility; parks and open space; urban design; and infrastructure systems. When all of the components are considered together, they functionally integrate to form a well-planned, vibrant, mixed use, pedestrian-oriented village.

In addition, this chapter provides design standards and policies that are applicable to future site planning and development proposals in the CENTRAL VILLAGE. Adherence to these standards and guidelines will ensure that the village builds out as intended and achieves the goals of this Specific Plan and the Otay Mesa Community Plan.

2.1.2 DEFINITION OF TERMS

The meaning of words, phrases, titles, and terms shall be the same as provided in the City of San Diego Land Development Code Chapter 11, Article 3, Division 1, unless otherwise specifically defined in this Specific Plan.

Throughout this Specific Plan, “Design Standards” and design “Policies” are identified. Design Standards are mandatory requirements for all future implementing developments. Policies are recommendations which offer guidance for the design for future development within the Specific Plan, and are provided to encourage creative and flexible design solutions during implementation.

2.1.3 APPLICABILITY

Design Standards and Policies set forth in this section apply to all development permits, development agreements, tract maps, parcel maps, site plans, conditional use permits, and any and all other actions requiring administrative or discretionary approval from the City of San Diego associated with the CENTRAL VILLAGE Specific Plan. Except as otherwise provided by this Specific Plan, no uses or structures shall be established, substituted, expanded, constructed, altered, moved, maintained, or otherwise changed, and no lot lines may be created or changed, except in conformance with this chapter and the various standards, restrictions, and requirements as set forth in Chapter 3.0, *Central Village Specific Plan Implementation*

Development Components...

1) Land Use

2) Parks and Open Space

3) Mobility

4) Urban Design

5) Infrastructure



This page intentionally left blank.

2.2 LAND USE ELEMENT

2.2.1 CENTRAL VILLAGE LAND USE PLAN

The CENTRAL VILLAGE is a 229.2-acre village designed to provide contemporary residential neighborhoods within easy walking distance to friends and family, shopping, jobs, parks, a school, and other uses. The CENTRAL VILLAGE provides for the development of up to 4,485 dwelling units. The Otay Mesa Community Plan indicates that the Otay Mesa community has approximately 3.45 persons per household (pph). Thus, the 4,485 dwelling units accommodated by this Specific Plan will yield approximately 15,473 residents in the CENTRAL VILLAGE (4,485 households x 3.45 pph = 15,473). As shown on Figure 2.2-1, *Specific Plan Land Use Plan*, and as summarized in Table 2.2-1, *Central Village Specific Plan Land Use Abstract*, the Specific Plan area is divided for planning purposes into 22 planning areas, containing the following land uses:

Moderate to High Density (MH) Mixed Use: Provides for up to 139,700 square feet of commercial land uses and 2,046 homes on 54.5 acres, within an allowable density range of 15 to 44 dwelling units per acre (du/ac);

Moderate to High Density (MH) Multi-Family: Provides for 495 homes on 12.4 acres, within an allowable density range of 15 to 44 du/ac;

Medium Density (MD) Multi-Family: Provides for 1,444 homes on 50.3 acres, within an allowable density range of 15 to 29 du/ac;

Low Density (LD) Multi-Family: Provides for 500 homes on 28.3 acres, within a density range of 10 to 29 du/ac;

Parks: Provides for passive and active recreation on 16.1 acres, intended to meet a portion of the population-based parkland requirements within the CENTRAL VILLAGE;

Open Space: Provides for the preservation of 15.9 acres of undeveloped open space; and

School/Recreation: Provides a public school site with public recreation areas on 13.1 acres. It should be noted that recreation areas may or may not be available for public use, as public use of this facility is subject to approval by the San Ysidro School District.

2.2.2 LAND USE DESIGN STANDARDS

All areas within the CENTRAL VILLAGE Specific Plan boundaries are subject to the City of San Diego Land Development Code, including Land Development



Moderate to High Density Mixed-Use



Moderate to High Density Multi-Family



Low Density Multi-Family



Neighborhood Park



Open Space



Code Chapter 13, *Zones*. In addition, applicability of the standards in this section is specified by both the Planning Districts Map (Figure 3-1) in Chapter 3.0, and the land use designations depicted on the Specific Plan Land Use Plan (Figure 2.2-1). The following land use design standards shall apply to future development within the CENTRAL VILLAGE. Development within the CENTRAL VILLAGE shall be subject to the use restrictions set forth in Table 3-1, *Central Village Specific Plan Use Supplemental Regulations*, and the Land Use Development Standards presented in Table 3-2, *Central Village Supplemental Development Regulations*, for the applicable Planning District shown on Figure 3-1, *Planning Districts Map*. City of San Diego Land Development Code provisions that are not specifically modified in Tables 3-1 and 3-2 shall apply.

Design Standard 2.2-1 In conformance with the Specific Plan Land Use Plan (Figure 2.2-1), a maximum of 4,485 dwelling units and up to 139,700 s.f. of commercial retail uses may be developed within the CENTRAL VILLAGE Specific Plan, except that in the event that Planning Area 14 is not developed with school/recreation uses, then this Planning Area may instead be developed with up to 197 MD Multi-Family homes through the Formal Specific Plan Amendment process, as specified in Section 3.9, *Formal Amendments*. In such a case, the total number of dwelling units allowed within the CENTRAL VILLAGE shall increase to 4,682 units, and if fully built, result in a future population of approximately 16,153 people (based on 3.45 persons per household per the Otay Mesa Community Plan). Any population-based park requirements for future residential development within Planning Area 14 shall be met on-site within Planning Area 14, or elsewhere within the CENTRAL VILLAGE. The CENTRAL VILLAGE accommodates up to 4,485 homes, which, if fully built out in accordance with the Specific Plan Land Use Plan depicted on Figure 2.2-1, results in a future population of approximately 15,473 people (based on 3.45 persons per household per the Otay Mesa Community Plan). Based on the required ratio of 2.8 useable park acres per 1,000 residents, the CENTRAL VILLAGE generates a maximum demand for 43.3 useable acres of parkland. As shown on Figure 2.2-1, the CENTRAL VILLAGE accommodates 16.1 net usable acres of parkland. The remainder of the CENTRAL VILLAGE population-based parkland requirement (27.2 acres) is accommodated in the Grand Park. As planned by the Otay Mesa Community Plan, the Grand Park will meet a portion of the population-based park requirements for the CENTRAL VILLAGE, with remaining areas within Grand Park reserved to serve other residents of the Central District and future residents within the Southwest District.

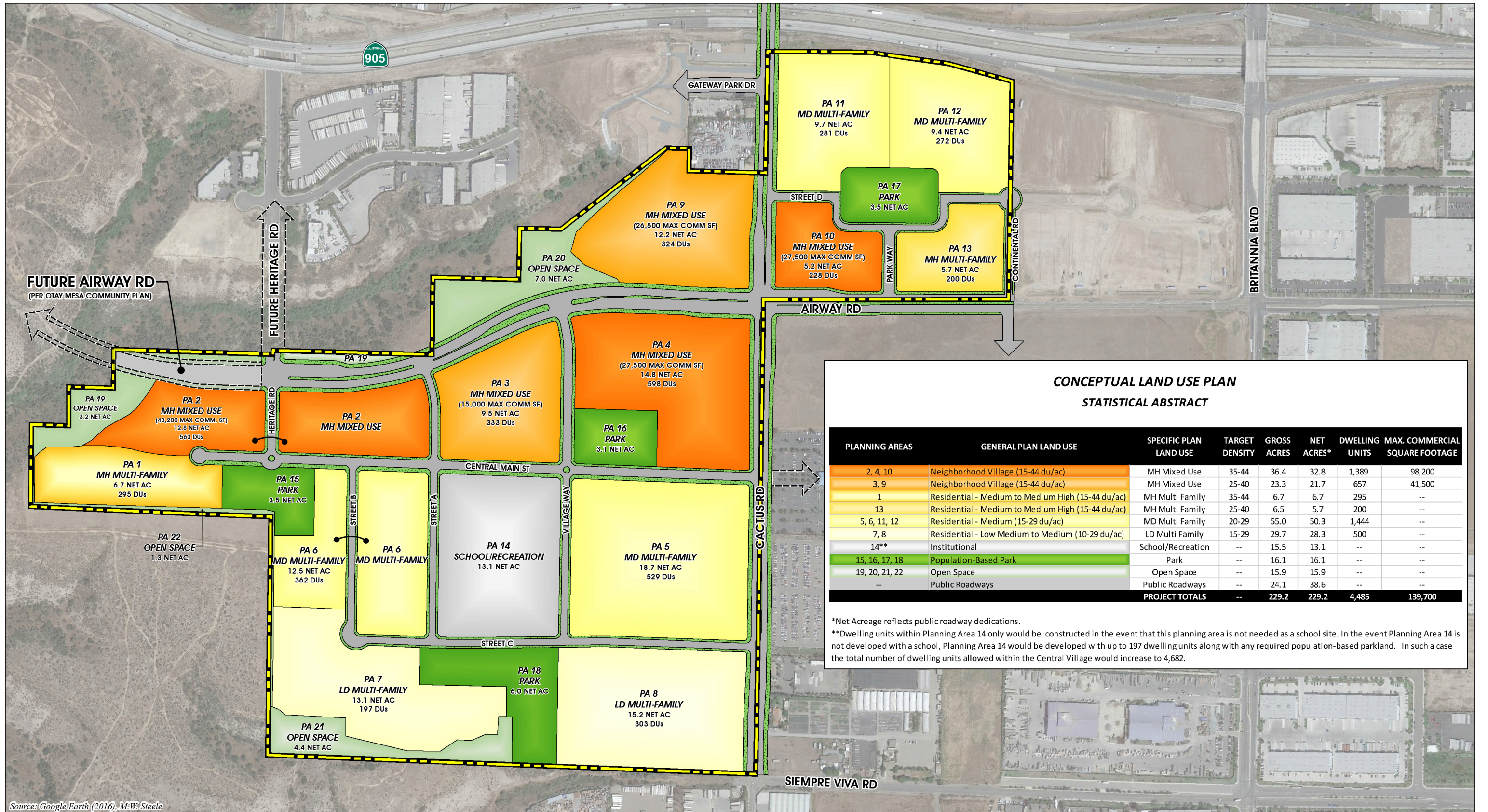

**CONCEPTUAL LAND USE PLAN
STATISTICAL ABSTRACT**

PLANNING AREAS	GENERAL PLAN LAND USE	SPECIFIC PLAN LAND USE	TARGET DENSITY	GROSS ACRES	NET ACRES*	DWELLING UNITS	MAX. COMMERCIAL SQUARE FOOTAGE
2, 4, 10	Neighborhood Village (15-44 du/ac)	MH Mixed Use	35-44	36.4	32.8	1,389	98,200
3, 9	Neighborhood Village (15-44 du/ac)	MH Mixed Use	25-40	23.3	21.7	657	41,500
1	Residential - Medium to Medium High (15-44 du/ac)	MH Multi Family	35-44	6.7	6.7	295	--
13	Residential - Medium to Medium High (15-44 du/ac)	MH Multi Family	25-40	6.5	5.7	200	--
5, 6, 11, 12	Residential - Medium (15-29 du/ac)	MD Multi Family	20-29	55.0	50.3	1,444	--
7, 8	Residential - Low Medium to Medium (10-29 du/ac)	LD Multi Family	15-29	29.7	28.3	500	--
14**	Institutional	School/Recreation	--	15.5	13.1	--	--
15, 16, 17, 18	Population-Based Park	Park	--	16.1	16.1	--	--
19, 20, 21, 22	Open Space	Open Space	--	15.9	15.9	--	--
--	Public Roadways	Public Roadways	--	24.1	38.6	--	--
PROJECT TOTALS			--	229.2	229.2	4,485	139,700

*Net Acreage reflects public roadway dedications.
 **Dwelling units within Planning Area 14 only would be constructed in the event that this planning area is not needed as a school site. In the event Planning Area 14 is not developed with a school, Planning Area 14 would be developed with up to 197 dwelling units along with any required population-based parkland. In such a case the total number of dwelling units allowed within the Central Village would increase to 4,682.

Source: Google Earth (2016), M.W. Steele

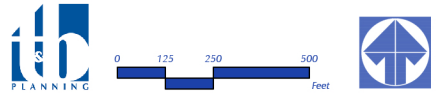

Figure 2.2-1



This page intentionally left blank.

Table 2.2-1 CENTRAL VILLAGE SPECIFIC PLAN LAND USE ABSTRACT

Planning Area	General Plan Land Use	Specific Plan Land Use	Target Density Range*	Gross Acres	Net Acres**	Dwelling Units	Projected Population	Maximum Commercial Square Footage
1	Neighborhood Village (15-44 du/ac)	MH Multi-Family	35-44	6.7	6.7	295	1,018	--
2	Neighborhood Village (15-44 du/ac)	MH Mixed Use	35-44	14.8	12.8	563	1,942	43,200
3	Neighborhood Village (15-44 du/ac)	MH Mixed Use	25-40	11.1	9.5	333	1,149	15,000
4	Neighborhood Village (15-44 du/ac)	MH Mixed Use	35-44	15.6	14.8	598	2,063	27,500
5	Residential – Medium (15-29 du/ac)	MD Multi-Family	20-29	20.0	18.7	529	1,825	--
6	Residential – Medium (15-29 du/ac)	MD Multi-Family	20-29	15.2	12.5	362	1,249	--
7	Residential – Low Medium to Medium (10-29 du/ac)	LD Multi-Family	15-29	13.6	13.1	197	680	--
8	Residential – Low Medium to Medium (10-29 du/ac)	LD Multi-Family	15-29	16.1	15.2	303	1,045	--
9	Neighborhood Village (15-44 du/ac)	MH Mixed Use	25-40	12.2	12.2	324	1,118	26,500
10	Neighborhood Village (15-44 du/ac)	MH Mixed Use	35-44	6.0	5.2	228	787	27,500
11	Residential – Medium (15-29 du/ac)	MD Multi-Family	20-29	10.0	9.7	281	969	--
12	Residential – Medium (15-29 du/ac)	MD Multi-Family	20-29	9.8	9.4	272	938	--
13	Neighborhood Village (15-44 du/ac)	MH Multi-Family	25-40	6.5	5.7	200	690	--
14	Institutional	School/Recreation	(15-29)***	15.5	13.1	(197)***	(680)***	--
15	Population-Based Park	Park	--	3.5	3.5	--	--	--
16	Population-Based Park	Park	--	3.1	3.1	--	--	--
17	Population-Based Park	Park	--	3.5	3.5	--	--	--



Table 2.2-1 CENTRAL VILLAGE SPECIFIC PLAN LAND USE ABSTRACT

Planning Area	General Plan Land Use	Specific Plan Land Use	Target Density Range*	Gross Acres	Net Acres**	Dwelling Units	Projected Population	Maximum Commercial Square Footage
18	Population-Based Park	Park	--	6.0	6.0	--	--	--
19	Open Space	Open Space	--	3.2	3.2	--	--	--
20	Open Space	Open Space	--	7.0	7.0	--	--	--
21	Open Space	Open Space	--	4.4	4.4	--	--	--
22	Open Space	Open Space	--	1.3	1.3	--	--	--
--	Circulation	Circulation	--	24.1	38.6	--	--	--
Specific Plan Totals:				229.2	229.2	4,485***	15,473***	139,700

* Target density is based on net acreage.

** Net acreage reflects public roadway dedications.

*** Dwelling units within Planning Area 14 only would be constructed in the event that this planning area is not needed as a school site. In the event Planning Area 14 is developed with residential units, the total number of dwelling units allowed within the CENTRAL VILLAGE would increase to 4,682 dwelling units and population would increase to 16,153 persons.

Design Standard 2.2-2 A maximum of 139,700 s.f. of commercial retail is allowed within the CENTRAL VILLAGE. Table 2.2-2, *Maximum Permitted Commercial Area*, shows the maximum commercial square footage allocated to each MH Mixed Use planning area within the CENTRAL VILLAGE. Allowable commercial square footage may be increased through a transfer of commercial area between planning areas, pursuant to Specific Plan Section 3.7, *Transfer of Commercial Square Footage*.

Table 2.2-2 MAXIMUM PERMITTED COMMERCIAL AREA

Planning Area	Maximum Permitted Commercial Area (Square Feet)
2	43,200
3	15,000
4	27,500
9	26,500
10	27,500
Total:	139,700

Design Standard 2.2-3 Where Village Entries or Residential Collectors, as defined on Specific Plan Figure 2.3-1, *Vehicular Mobility Plan*, intersect with Central Main Street, and at the southwest corner of Planning Area 4 (adjacent to Village Central Park), commercial uses on the ground floor within the MH Mixed Use areas shall provide “Active Frontage” where feasible and appropriate. Active Frontage uses include retail, restaurants, and other similar active commercial uses at the ground level, and are intended to foster visual engagement between those on the street and the commercial spaces. Commercial and office uses that do not promote an active street frontage in these locations are discouraged.

Design Standard 2.2-4 No building permits, grading permits, or improvement plans shall be issued by the City of San Diego within the CENTRAL VILLAGE until a Development Permit is approved by the City of San Diego. For purposes of this standard, “Development Permit” refers to Neighborhood Development Permits (per Land Development Code Chapter 12, Article 6, Division 4), Site Development Permits (per Land Development Code Chapter 12, Article 6, Division 5), and/or Planned Development Permits (per Land Development Code Chapter 12, Article 6, Division 6).

Design Standard 2.2-5 A review in conformance with the California Environmental Quality Act (CEQA) shall be conducted to determine



potential environmental impacts resulting from each implementing Development Permit, subdivisions, or any discretionary land use application required to implement the Specific Plan. Any required CEQA review shall be conducted as part of the review process for implementing projects.

Design Standard 2.2-6 Prior to the submittal of any grading permit or right-of-way permit, future applications for subdivision may be accompanied by a request to the City of San Diego to enter into a Reimbursement Agreement for eligible facilities. Based on the Public Facilities Financing Plan (PFFP), facilities eligible for a Reimbursement Agreement include Airway Road, Cactus Road, Heritage Road, and Heritage Road Bridge. Any Reimbursement Agreement would be processed with the Facilities Financing section of the Planning Department, subject to City Council approval, and would be effective prior to submittal of any grading permit or right-of-way permit.

Design Standard 2.2-7 Planning areas designated by this Specific Plan and parcels created pursuant to any implementing tentative parcel or tentative tract maps shall be in conformance with the design standards specified throughout the CENTRAL VILLAGE Specific Plan.

Design Standard 2.2-8 Prior to issuance of a building permit for the construction of any use contemplated by this Specific Plan approval, the applicant shall first demonstrate that all pertinent conditions of approval imposed on the Specific Plan upon its adoption have been satisfied for the phase of development under consideration.

Design Standard 2.2-9 Development applications that incorporate common areas shall be accompanied by design plans for the common areas, specifying location and extent of landscaping, irrigation systems, structures, and circulation (vehicular and non-vehicular).

Design Standard 2.2-10 Prior to the issuance of building permits, improvement and irrigation plans for adjacent common areas shall be submitted for approval by the Development Services Department. Irrigation plans shall be certified by a landscape architect.

Design Standard 2.2-11 Mechanical air quality filtration systems shall be required for residential units in Planning Areas 9, 10, 11, 12, and 13 (the planning areas closest to SR-905) and for residential units in Planning Areas 5 and 8 that are within 500 feet of the Specific Plan's eastern and southern boundary lines (the planning areas closest to off-site light and heavy industrial uses) as part of implementing development projects. The filtration systems shall have at least a Maximum Efficiency

Reporting Value (MERV) of 13. These systems are required to improve indoor air quality in areas of the Specific Plan that could be most affected by vehicular-related air pollutant emissions along SR-905 and nearby stationary sources associated with off-site industrial land uses.

Design Standard 2.2-12 Developments within the CENTRAL VILLAGE shall be required to comply with the Airport Land Use Compatibility Overlay Zone of the San Diego Land Development Code, which implements the policies and criteria in the Airport Land Use Compatibility Plan (ALUCP) applicable to Brown Field Municipal Airport. Compliance with the ALUCP is required because the CENTRAL VILLAGE is located within the Airport Influence Area for Brown Field Municipal Airport, and properties within the CENTRAL VILLAGE may be subject to some of the annoyances or inconveniences associated with proximity to an airport and aircraft operations (for example, noise, vibration, overflights or odors). The City of San Diego Airport Division may be contacted for information regarding hours of operation, master plans, and other relevant information regarding airport operations. The FAA shall have the sole and exclusive regulatory authority over the operation of aircraft.

Design Standard 2.2-13 Drive-through commercial site design is prohibited within CENTRAL VILLAGE.



This page intentionally left blank.

2.3 MOBILITY ELEMENT

The CENTRAL VILLAGE roadway system is shown on Figure 2.3-1, *Vehicular Mobility Plan*, and depicted on Figure 2.3-2 and Figure 2.3-3, *Street Cross-Sections*. As shown, the circulation system includes a hierarchy of roads that provide safe and efficient access throughout CENTRAL VILLAGE. The design and orientation of the primary roadway network provides the structure for grid pattern street systems within the individual planning areas. Main roads intersect one another at right angles. This forms the master grid, within which the secondary grids will occur. In the CENTRAL VILLAGE, the development pattern is intended to be strongly influenced by the public street grid. A description of the primary roadways and design standards for each roadway is provided below. Additional design standards are provided in Section 2.5, *Urban Design Element*.

2.3.1 VEHICULAR MOBILITY DESIGN STANDARDS

2.3.1.1 Airway Road

Airway Road serves as the main east-west connector through the northern portion of CENTRAL VILLAGE and provides a connection between the Southwest Village (located west of the CENTRAL VILLAGE in the southwestern portion of the Otay Mesa Community Plan) and the employment and industrial areas located in the eastern portion of Otay Mesa. Airway Road includes three different roadway classifications, which are designed to accommodate the three different General Plan roadway designations for Airway Road.

A. Airway Road Segment (Six-Lane Primary Arterial)

The segment of Airway Road between Heritage and Cactus Road is designated by the Otay Mesa Community Plan as Six-Lane Primary Arterial. The following design standard applies to this portion of Airway Road.

Design Standard 2.3-1 The segment of Airway Road between Heritage and Cactus Road shall be constructed in accordance with the standards presented in Table 2.3-1, *Central Village Roadway Improvement Standards*, for the segment of Airway Road between Heritage Road and Cactus Road, and in accordance with the “Airway Road (6-Lane Prime Arterial)” diagram on Figure 2.3-2, *Street Cross-Sections*.

B. Airway Road (Six-Lane Urban Major)

The segment of Airway Road east of Cactus Road is designated by the Otay Mesa Community Plan as Six-Lane Major. The following design standard applies to this portion of Airway Road.



Table 2.3-1 CENTRAL VILLAGE ROADWAY IMPROVEMENT STANDARDS

Specific Plan Roadways	Segment(s)	Classification	ROW	Curb-to-Curb Width	Number of Travel Lanes (Width)	Median	Bike Facilities	Northern/ Eastern Parkway	Southern/ Western Parkway
Airway Road	Heritage Rd to Cactus Rd	6-Lane Prime Arterial	142'	98'	Six (11')	16' Raised and Landscaped	5' wide Class II Bike Lanes w/ 3' buffer from travel lanes; Class 1 Bike Lane	17' wide, w/ 6' wide non-contiguous sidewalk	27' wide with 6' non-contiguous sidewalk, Class 1 Bike Lane, and a total of 11' of landscaped buffers
	Cactus Rd to Continental Rd	6-Lane Urban Major	139'	98'	Six (11')	16' Raised and Landscaped	5' wide Class II Bike Lanes w/ 3' buffer from travel lanes; Class 1 Bike Lane	14' wide w/ 6' wide non-contiguous sidewalk	27' wide, with 6' non-contiguous sidewalk, Class 1 Bike Lane, and a total of 11' of landscaped buffer
	Heritage Rd to Western Specific Plan Boundary	4-Lane Major (Bridge)	90'	64'	Four (11')	4' Raised	5' wide Class II Bike Lanes w/ 3' buffer from travel lanes; Class 1 Bike Lane	6' wide contiguous sidewalk	20' wide, with 6' wide non-contiguous sidewalk, Class 1 Bike Lane, and 4' of non-landscaped buffer areas
Cactus Road	Siempre Viva Rd to Airway Road	4-Lane Major	114'	76'	Four (11')	16' Raised and Landscaped	5' wide Class II Bike Lanes w/ 3' buffer from travel lanes	12' wide w/ 6' wide non-contiguous sidewalk	26' wide with 8' wide non-contiguous sidewalk
	Airway Road to Northern Specific Plan Boundary	4-Lane Major	126'	102'	Four (11'), w/ three 12' wide turning lanes	6' Raised	5' wide Class II Bike Lanes w/ 3' buffer from travel lanes	12' wide w/ 6' wide non-contiguous sidewalk	12' wide w/ 6' wide non-contiguous sidewalk
Heritage Road	North of Airway Rd	6-Lane Major (Bridge)	116'	102'	Four (11'), w/ three 12' wide turning lanes	6' Raised	5' wide Class II Bike Lanes w/ 3' buffer from travel lanes	7' wide with contiguous sidewalks	7' wide with contiguous sidewalks
Village Entry Street	Heritage Rd (south of Airway Rd)	Two-way Collector w/ Two-way Left Turn Lane	86-97'	64'-73'	Two (11'), w/ two 7' wide parking lanes	10'-21' wide varying two-way left turn lane	5' wide Class II Bike Lanes w/ 3' buffer from travel lanes	12' wide w/ 6' non-contiguous sidewalks	12' wide with 6' non-contiguous sidewalks
Village Entry Street	Village Way (north of Village Way), Street D (west of Park Way), and Continental Rd	Two-way Collector w/ Two-way Left Turn Lane	86'	62'	Two (11'), w/ two 7' wide parking lanes	10' wide two-way left turn lane	5' wide Class II Bike Lanes w/ 3' buffer from travel lanes	12' wide w/ 6' non-contiguous sidewalks	12' wide with 6' non-contiguous sidewalks
Green Street	Central Main Street and Park Way	Two-way Collector w/ Two-way Left Turn Lane	80'	46'	Two (11') w/ two 7' wide parking lanes	10' wide two-way left turn lane	Class I Bike Lane	12' wide w/ 6' wide non-contiguous sidewalk	22' wide with 6' wide non-contiguous sidewalk, Class I Bike Lane, and a total of 8' of landscaped buffer areas
Green Street (Diagonal Parking Option)	Central Main Street and Park Way	Two-way Collector w/ Two-way Left Turn Lane	92'	58'	Two (11') w/ one 7' wide parking lane, and one 19' wide 45 degree diagonal parking lane	10' wide two-way left turn lane	Class I Bike Lane	12' wide w/ 6' wide non-contiguous sidewalk	22' wide with 6' wide non-contiguous sidewalk, Class I Bike Lane, and a total of 8' of landscaped buffer areas
Residential Collector	Streets A, B, C, and D (east of Park Way), and Village Way (south of Central Main Street)	Two-Lane Collector	60'	36'	Two (11') w/ two 7' wide parking lanes	None	None	12' wide w/ 6' wide non-contiguous sidewalk	12' wide w/ 6' wide non-contiguous sidewalk
Private Internal Roadway	N/A	N/A	32'-46'	22'-36' ¹	Two (11') w/ (optional) two 7' wide parking lanes	None	None	5' wide contiguous sidewalk	5' wide contiguous sidewalk
Alleys	N/A	N/A	N/A	20'-26' ²	Two (10')	None	None	N/A	N/A

1. Private Internal Roadways shall have a 22' to 26' curb-to-curb width, subject to Fire Department approval.
2. Alleys shall have a 20' to 26' curb-to-curb width, subject to Fire Department approval.

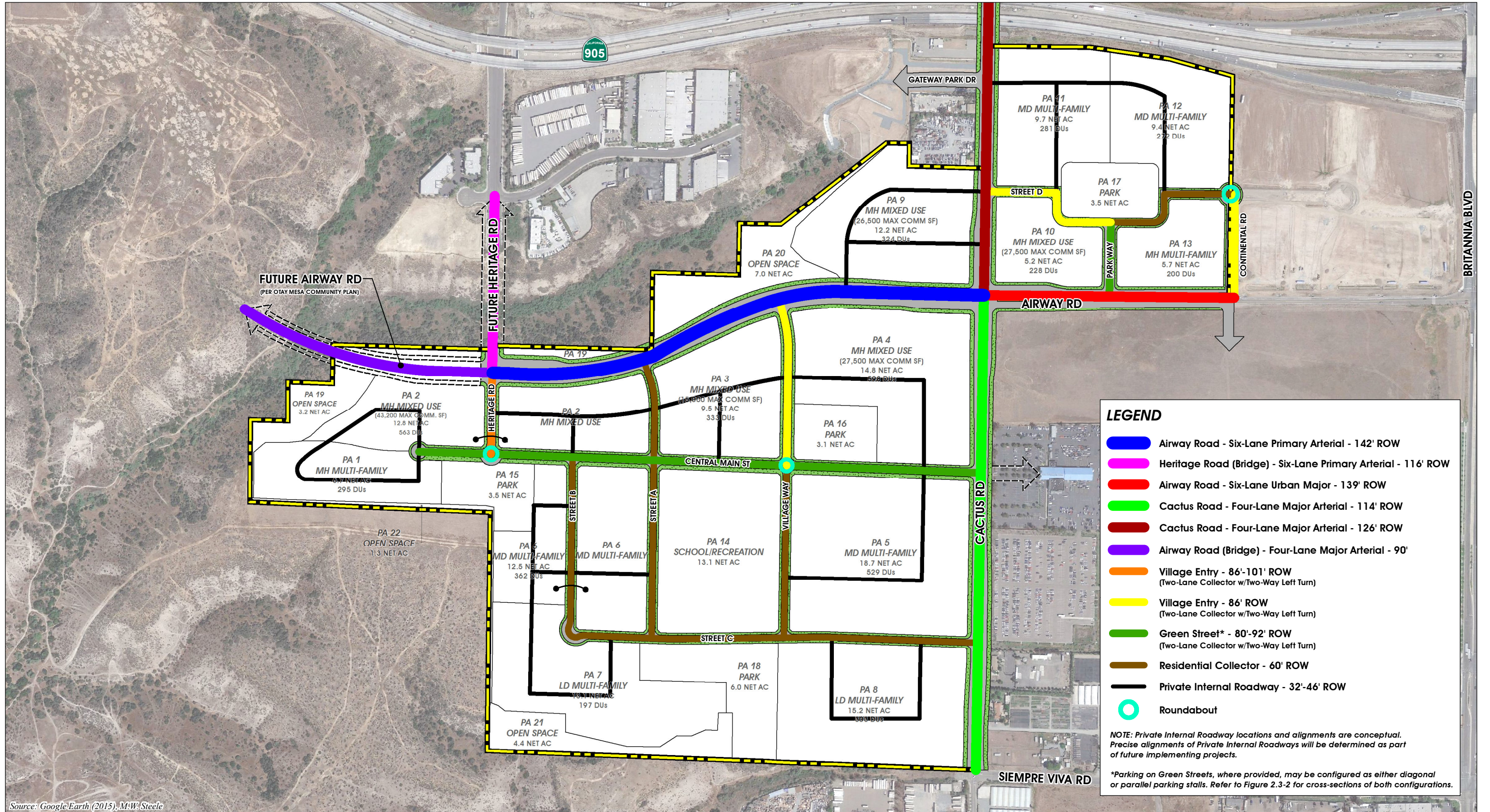

Source: Google Earth (2015), M.W. Steele

Figure 2.3-1

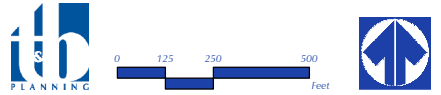

This page intentionally left blank.

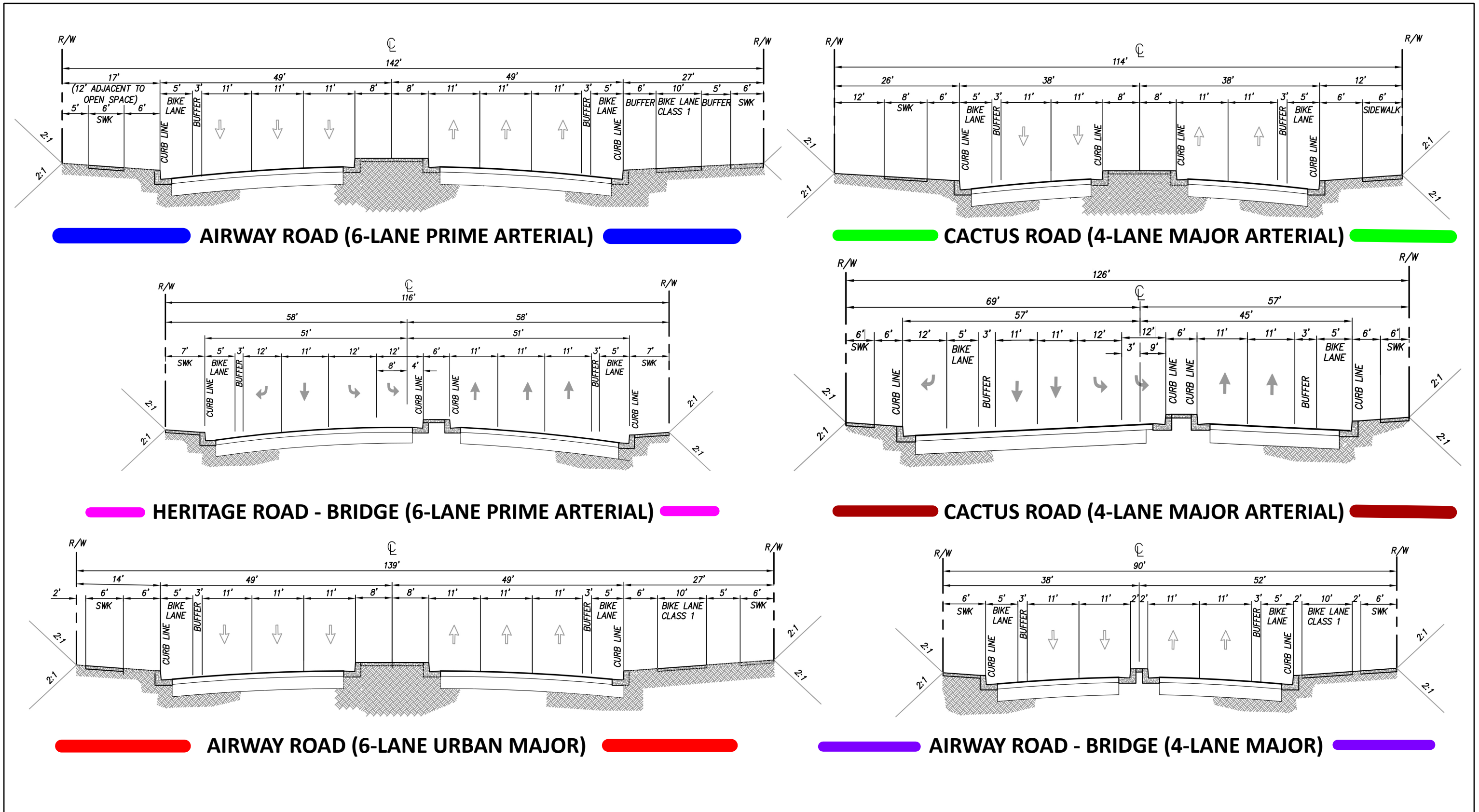
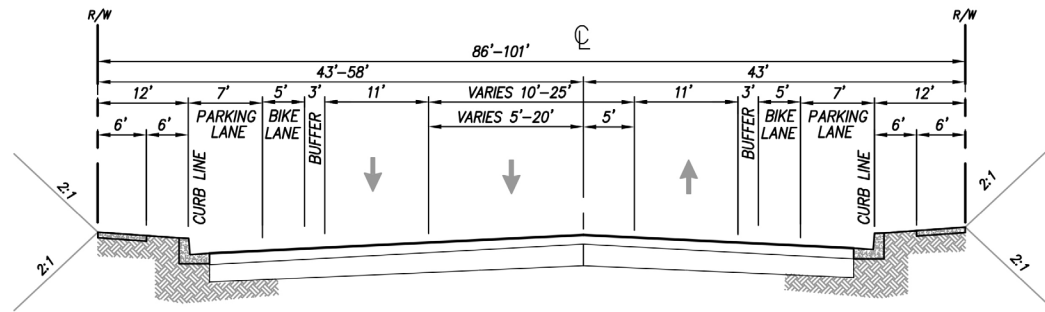

Figure 2.3-2



This page intentionally left blank.



VILLAGE ENTRY STREET
(Two way collector with two-way left turn lane)

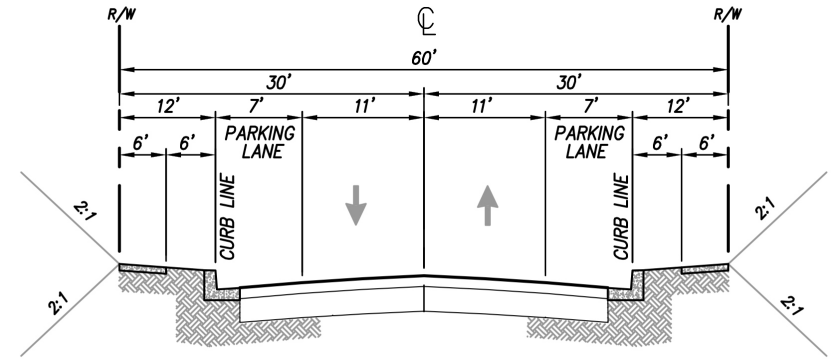

RESIDENTIAL COLLECTOR

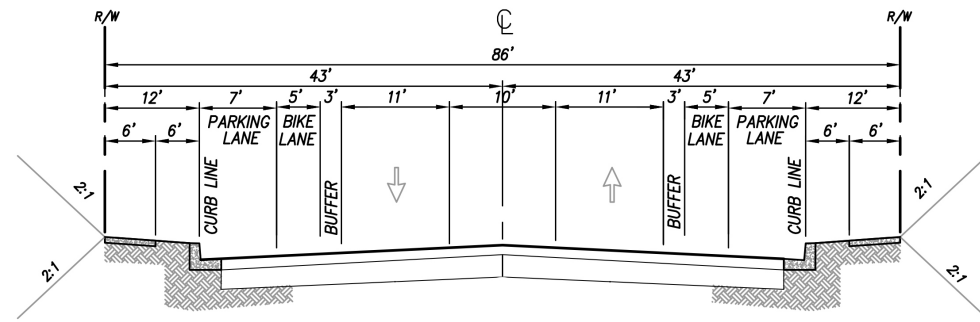

VILLAGE ENTRY STREET
(Two way collector with two-way left turn lane)

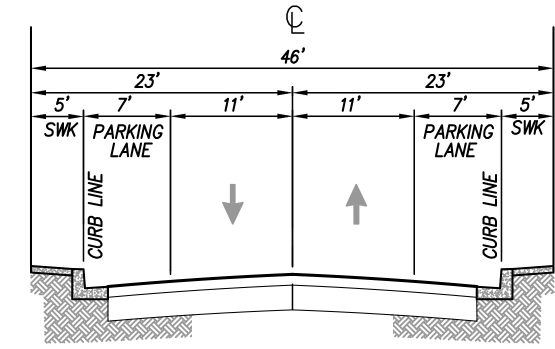

PRIVATE INTERNAL ROADWAY

1. Parking lanes are optional.
2. A minimum 22 foot curb-to-curb width is required, subject to approval by the City of San Diego Fire Department.

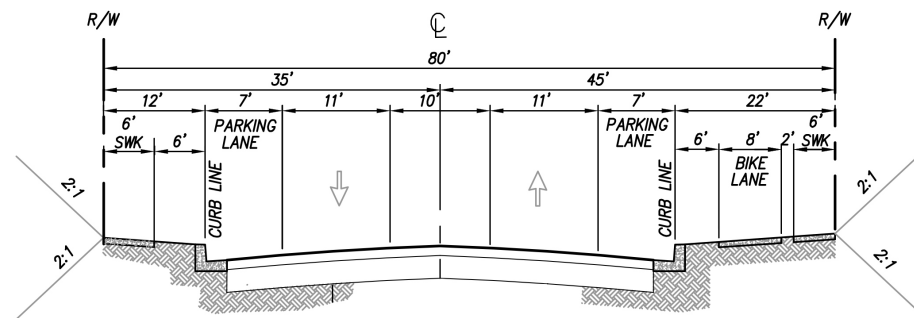

GREEN STREET
(Two way collector with two-way left turn lane)

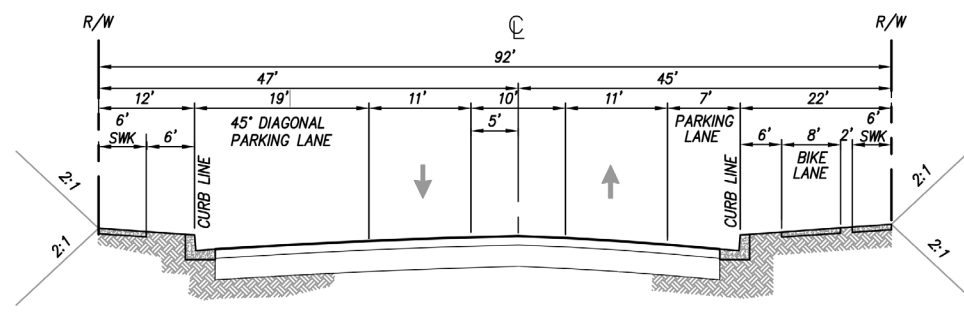

GREEN STREET
(Two way collector with two-way left turn lane)
(Diagonal Parking Option)

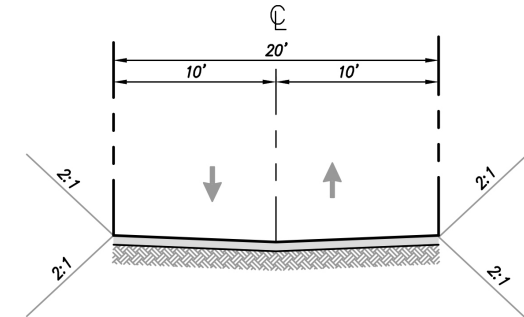

PRIVATE ALLEY



This page intentionally left blank.

Design Standard 2.3-2 The segment of Airway Road located between Cactus Road and Continental Road shall be constructed in accordance with the standards presented in Table 2.3-1, *Central Village Roadway Improvement Standards*, and in accordance with the “Airway Road (6-Lane Urban Major)” diagram on Figure 2.3-2, *Street Cross-Sections*.

C. Airway Road (Four-Lane Major)

A small segment of Airway Road, west of Heritage Road, is located within the Specific Plan area and is designated by the Otay Mesa Community Plan as Four-Lane Major. This portion of Airway Road includes a 4-lane bridge crossing over Spring Canyon to the west.

This segment of Airway Road cannot be constructed until a grade and alignment study is completed for the roadway and bridge. The following design standard applies to this segment of Airway Road. A full intersection shall be constructed at Airway Road and Heritage Road, and a segment of Airway Road up to 100 lineal feet in length may be constructed by implementing developments within the CENTRAL VILLAGE west of Heritage Road.

Design Standard 2.3-3 The segment of Airway Road between Heritage Road and the western boundary of the Specific Plan shall be constructed in accordance with the standards presented in Table 2.3-1, *Central Village Roadway Improvement Standards*, and in accordance with the “Airway Road Bridge (4-Lane Major)” diagram on Figure 2.3-2, *Street Cross-Sections*.

2.3.1.2 Cactus Road

Cactus Road is a north-south oriented roadway located along the eastern portion of CENTRAL VILLAGE. The Otay Mesa Community Plan designates Cactus Road as Four-Lane Major. Implementing developments within the CENTRAL VILLAGE are responsible for constructing half-width improvements to the segment of Cactus Road between Siempre Viva Road and Airway Road, and full-width improvements between Airway Road and the northern boundary of Planning Area 9. Half-width improvements would be constructed between the northern boundary of Planning Area 9 and the northern boundary of Planning Area 11. The implementing developments shall also be responsible for constructing any improvements required to connect them to the existing roadway network, along with any additional improvements at locations where they are shown to have direct significant traffic impacts as part of the required traffic studies for implementing developments. The following design standard shall apply to Cactus Road:



Design Standard 2.3-4 Cactus Road shall be constructed in accordance with the standards presented in Table 2.3-1, *Central Village Roadway Improvement Standards*, and in accordance with the “Cactus Road (4-Lane Major)” diagram on Figure 2.3-2, *Street Cross-Sections*.

2.3.1.3 Heritage Road

Heritage Road is a north-south roadway that will provide a connection between SR-905 to the north and Central Main Street within the CENTRAL VILLAGE. A short segment of Heritage Road occurs in the CENTRAL VILLAGE, north of Airway Road. Along this segment, Heritage Road would consist of a six-lane bridge spanning between Airway Road and the existing improved segment of this road just south of Gateway Park Drive. North of the bridge, Heritage Road is classified by the Otay Mesa Community Plan as a Six-Lane Prime Arterial.

The following design standard applies to the segment of Heritage Road located north of Airway Road.

Design Standard 2.3-5 The portion of Heritage Road that occurs within the Specific Plan (i.e., between Airway Road and the northern Specific Plan boundary) shall be constructed in accordance with the standards presented in Table 2.3-1, *Central Village Roadway Improvement Standards*, and in accordance with the “Heritage Road Bridge (6-Lane Prime Arterial)” diagram on Figure 2.3-2, *Street Cross-Sections*.

2.3.1.4 Green Streets

Central Main Street and Park Way are public streets herein labeled Green Streets (Two Lane Collector with Two-Way Left Turn Lane). Green Streets are designed to provide a cohesive and functional environment for all roadway users including drivers, bicyclists, and pedestrians. The design of Green Streets within the CENTRAL VILLAGE helps to achieve the Otay Mesa Community Plan’s goal of creating a multi-modal, pedestrian-oriented Main Street within the CENTRAL VILLAGE area. Where on-street parking is feasible and desirable, on-street parking provided on Green Streets may be configured as either diagonal or parallel parking stalls. Due to the abundance of amenities, Central Main Street and Park Way are anticipated to be the most active streets in CENTRAL VILLAGE (see Figure 2.5-32 for a rendering depicting Green Streets).



Example of a “Green Street.”

Central Main Street is an east-west oriented corridor road that traverses the central portion of CENTRAL VILLAGE. This road provides access between Vista Park (Planning Area 15) in the west, the school site, several residential and

mixed use planning areas, and the Grand Park located east of the CENTRAL VILLAGE.

Park Way is a north-south oriented street located between Planning Areas 10 and 13. These roadways are two-lane collector streets that contain two-way left turn lanes (a center lane used to turn left from either direction). The following design standard shall apply to Central Main Street and Park Way:

Design Standard 2.3-6 Central Main Street and Park Way shall be constructed in accordance with the standards presented in Table 2.3-1, *Central Village Roadway Improvement Standards*, for Green Streets, and in accordance with the “Green Street” diagram on Figure 2.3-3, *Street Cross-Sections*.

The following policies also apply to Green Streets.

Policy 2.3-1 If possible, include transit stops to support transit use within the CENTRAL VILLAGE.

Policy 2.3-2 Traffic calming features, such as roundabouts and bulb-outs at street intersection crossings, are encouraged.

2.3.1.5 Village Entry Streets

Village Entry Streets (Two Lane Collector with Two-Way Left Turn Lane) are public streets within the CENTRAL VILLAGE that serve as the primary entry points into the community. With exception of Continental Road (which does not abut commercial land uses within the Specific Plan area), the Village Entries are intended to complement the mixed use character of adjacent planning areas. Continental Road also is planned as a Village Entry Street because the intersection of Airway Road at Continental Road provides the only signalized access point to the commercial and residential uses planned north of Airway Road and east of Cactus Road. These roadways are two-lane collector streets with two-way left-turn lanes (a center lane used to turn left from either direction). The Village Entry Street at Heritage Road, South of Airway Road has a varying width for the two-way left turn lane, but features the same two way collector with two-way left turn lane feature as the other Village Entry Streets. The following design standard applies to Village Entries:

Design Standard 2.3-7 Village Entries shall be constructed in accordance with the standards presented in Table 2.3-1, *Central Village Roadway Improvement Standards*, for Village Entry Streets, and in accordance with the “Village Entry Street” diagram on Figure 2.3-3, *Street Cross-Sections*.



2.3.1.6 Residential Collectors

Residential Collectors are public streets within CENTRAL VILLAGE which are two-lane collector streets that provide direct access to residential planning areas. The following design standard applies to roadways that are designated as Residential Collectors.

Design Standard 2.3-8 Residential Collectors shall be constructed in accordance with the standards presented in Table 2.3-1, *Central Village Roadway Improvement Standards*, for Residential Collector, and in accordance with the “Residential Collector” diagram on Figure 2.3-3, *Street Cross-Sections*.

2.3.1.7 Private Internal Roadways

Private Internal Roadways within CENTRAL VILLAGE are private roadways that provide access within and between the multi-family and mixed use planning areas. The orientation of Private Internal Roadways will be determined as development plans are proposed for individual planning areas. These roads are envisioned to be designed in a grid or modified grid pattern to encourage walking and enhance connectivity within and through each planning area.

The following design standards apply to Private Internal Roadways.

Design Standard 2.3-9 Private Internal Roadways shall be constructed in accordance with the standards presented in Table 2.3-1, *Central Village Roadway Improvement Standards*, and in accordance with the “Private Internal Roadway” diagram on Figure 2.3-3, *Street Cross-Sections*.

Design Standard 2.3-10 Private Internal Roadways shall be designed in a grid pattern and shall to the extent practical align with Private Internal Roadways within adjacent planning areas in order to promote non-vehicular mobility and connection through the CENTRAL VILLAGE.

Design Standard 2.3-11 Private Internal Roadways shall not create internal loops and/or dead ends that would result in enclosed and gated planning areas.

2.3.1.8 Private Alley

Private Alleys connect to internal roadways and provide access to individual garages within each planning area. The following design standard applies to Private Alleys.

Design Standard 2.3-12 Private Alleys shall be constructed in accordance with the standards presented in Table 2.3-1, *Central Village Roadway Improvement Standards*, and in accordance with the “Private Alley” diagram on Figure 2.3-3, *Street Cross-Sections*.

2.3.2 ALTERNATIVE TRANSPORTATION DESIGN STANDARDS AND POLICIES

CENTRAL VILLAGE contains a comprehensive, interconnected non-vehicular mobility system that connects residents and visitors to homes, retail establishments, parks, trails, and the school. As shown on Figure 2.3-4, *Alternative Transportation Plan*, the mobility system consists of future transit stations along Airway Road, bicycle facilities, and pedestrian connections including sidewalks, pedestrian paseos, pedestrian nodes, and a trail located parallel to Cactus Road (south of Central Main Street) and along the southern boundary of CENTRAL VILLAGE.

2.3.2.1 Public Transit

The CENTRAL VILLAGE Specific Plan area currently is served by Metropolitan Transit System (MTS) express Routes 905, 905A, and 950. Route 905 generally runs along Otay Mesa Road and the SR-905. Route 905A takes a similar route as Route 905, but provides local service to industrial uses located south of Airway Road near Britannia Boulevard. Route 950 is an express route with limited stops. All three of these Routes provide service between the SR-905 Otay Mesa Port of Entry in the east and the Iris Avenue transfer station in the west. In addition, the Otay Mesa Community Plan identifies a planned future rapid transit route along Airway Road to link CENTRAL VILLAGE with other key activity centers and employment nodes within Otay Mesa.

A. Bus Facilities

MTS service is provided to the Specific Plan area via Route 905A, which has a station stop located at the intersection of Airway Road and Britannia Boulevard, approximately 0.25 mile east of the CENTRAL VILLAGE. Weekly service at the nearest station stop occurs in intervals between 15 minutes during peak morning hours, up to two hours during Sunday/holiday service. In 2015 when this Specific Plan was prepared, there were no planned bus facilities within the Specific Plan area; however, design standards are provided below for planned future bus facilities within CENTRAL VILLAGE.

Concrete bus pads shall be required for bus stops along Airway Road and shall consist of nine inches of Portland cement concrete. Refer to the City of San Diego Metropolitan Transit Development Board (MTDB) Design Guidelines for other required dimensions, as well as the design guidelines



MTS bus service



provided in the “Transit Stations” portion of SANDAG’s publication, “Designing for Smart Growth.”

Design Standard 2.3-13 Sidewalk widths shall be 8 or 10-feet wide where transit stops and shelters are proposed and shall extend for 25 feet parallel to the curb measured from the bus stop sign to provide adequate clearance to accommodate bus lifts for disabled persons.

Design Standard 2.3-14 The edge zone (space between the roadway and sidewalk) shall be a minimum of 4 feet to provide wheelchair access to the shelter. In constrained conditions, the edge zone may be reduced to 2^{1/2} feet.

Design Standard 2.3-15 Bus facilities shall be developed in accordance with the standards provided in the City of San Diego Street Design Manual.

B. Rapid Transit Facilities

The Otay Mesa Community Plan identifies a future rapid transit route along Airway Road, a segment of which will pass along Airway Road through the CENTRAL VILLAGE area. As shown on Figure 2.3-4, *Alternative Transportation Plan*, transit stops will be provided along Airway Road at Continental Road, Village Way, and Heritage Road. The following design standards apply to rapid transit facilities.

Design Standard 2.3-16 Rapid Transit stops shall be designed to allow pedestrians to cross the street safely and within proximity to the stop.

Design Standard 2.3-17 Rapid Transit facilities shall be developed in accordance with the standards provided in the City of San Diego Street Design Manual.

2.3.2.2 Bicycle Facilities

As shown on Figure 2.3-4, *Alternative Transportation Plan*, bicycle facilities are provided along most of the roadways within CENTRAL VILLAGE. Two types of bicycle facilities occur within CENTRAL VILLAGE.

Class I Bike Lane: Class I bike lanes are separated from vehicular traffic by a curb and buffer zone or tree-lined parkway and accommodate two lanes (one bike lane in each direction). Class I bike lanes are provided along the south side of Airway Road and on one side of the road along Central Main Street and Park Way.

Class II Bike Lane: Class II bike lanes are on-street lanes that are generally bordered by a landscaped parkway adjacent to a sidewalk. Along Village



Class II bike lanes adjacent to parking.

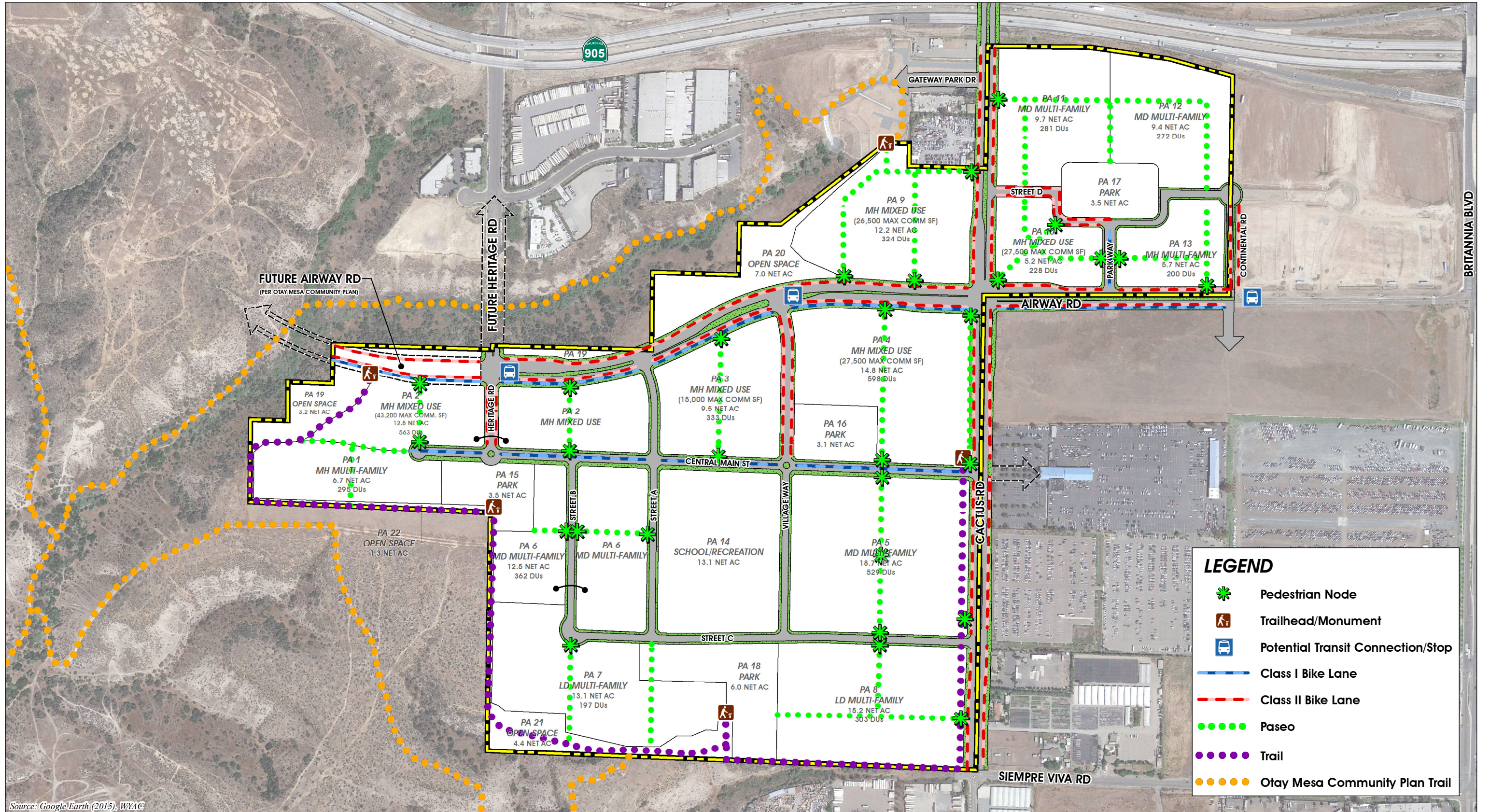

Source: Google Earth (2015), WYAC

Figure 2.3-4

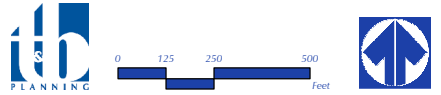

This page intentionally left blank.

Entry Streets, Class II bike lanes occur between the parking lane and the vehicular travel way, and are separated from vehicular traffic by a 3-foot wide buffer. Class II bike lanes are provided along both sides of the streets along Airway Road, Heritage Road, Cactus Road, and Village Entry streets.

The following design standard applies to bicycle facilities within the CENTRAL VILLAGE.

Design Standard 2.3-18 Class I and Class II bike lanes shall be developed in the locations depicted on Figure 2.3-4, *Alternative Transportation Plan*, and in accordance with the widths and specifications shown on Figure 2.3-2 and Figure 2.3-3, *Street Cross-Sections*.

2.3.2.3 Pedestrian Connections

In addition to traditional sidewalks, pedestrian connections in the CENTRAL VILLAGE include paseos, pedestrian nodes, and trails, which connect pedestrians to parks and other destinations within the CENTRAL VILLAGE. This pedestrian system encourages walking throughout the village by providing a safe and pleasant pedestrian environment that is separated from vehicular traffic along backbone roadways. The various pedestrian connections accommodated in the CENTRAL VILLAGE are described below.

Paseos: As shown on Figure 2.3-4, *Alternative Transportation Plan*, a grid of paseos serve as the connective fabric of the CENTRAL VILLAGE. They are a smaller network of pedestrian passageways that are woven into the larger circulation grid. The placement of paseos shown on Figure 2.3-4 is conceptual and the final location of paseos will be determined at the tract map stage. Paseos will be maintained either by the Master Homeowners' Association (HOA) or a Maintenance Assessment District (MAD); however, all paseos within the CENTRAL VILLAGE will be publicly accessible facilities.

The paseo networks serve three primary functions: 1) to promote walkability and connections to various destinations throughout the community by shortening the length of blocks; 2) to provide residents with direct pedestrian access to and from their homes; and 3) to connect the four public parks to create a seamless network of green spaces throughout the community. Paseos reinforce the pedestrian nature of the community by promoting walking and providing an aesthetically pleasing environment throughout CENTRAL VILLAGE.

Pedestrian Node: Integrated into the paseo system is a network of pedestrian nodes that occur where high pedestrian densities are anticipated to occur. These nodes provide places for residents and visitors to sit, relax,



Paseos promote walking in the village. Informal pedestrian gathering areas may be integrated into the paseo design.



Paseos within the CENTRAL VILLAGE provide places to sit, relax, and observe.





Pedestrian node adjacent to park.

and observe. Each node displays cohesive design elements, which help to tie the community together and reinforce its visual identity. Pedestrian nodes add vibrancy to CENTRAL VILLAGE as they promote activity by allowing pedestrians to gather along paseos and engage with each other. Pedestrian nodes may occur within or outside of the right-of-way. Pedestrian nodes within the public right-of-way shall be allowed only subject to review and approval by the City of San Diego Development Services staff. All pedestrian nodes within the CENTRAL VILLAGE are proposed to be maintained by a Maintenance Assessment District (MAD) or other similar public maintenance entity.

Trails: Trails within CENTRAL VILLAGE connect to adjacent existing trails and provide pedestrians, hikers, and bicyclists with additional passive and recreational uses and further enhance the active character of the CENTRAL VILLAGE.

As shown on Figure 2.3-4, *Alternative Transportation Plan*, a trail is located along the southern portion of the Specific Plan area to provide safe access to the off-site open space areas and extends northerly, parallel to Cactus Road, to a proposed trailhead/monument provided at the intersection of Cactus Road and Central Main Street. This trail connects the CENTRAL VILLAGE to the planned Otay Mesa Community Plan regional open space and trail network, and to the Grand Park east of Cactus Road (refer also to Figure 2.4-1).

The following design standards and policies apply to pedestrian connections within the CENTRAL VILLAGE.

Design Standard 2.3-19 The design of mid-block crosswalks and crosswalks at uncontrolled intersections shall comply with Council Policy 200-07, the San Diego Street Design Manual, and other industry standards to the satisfaction of the City Engineer.

Policy 2.3-3 Design street corners to accommodate safe pedestrian crossings. Include ample unobstructed space at the street corner for people waiting to cross the street. Where there is demand for a pedestrian street crossing that does not align with an intersection, apply a mid-block crossing.

Policy 2.3-4 Provide interconnected streets and pedestrian walkways. Avoid barriers to pedestrian access, such as:

- Walls, fences, and gates that separate related uses or isolate neighborhoods;
- Cul-de-sacs and dead end streets that cut off access within neighborhoods;

- Disconnected bike and pedestrian paths;
- Wide streets that lack sidewalks and landscaping;
- Street-adjacent parking lots that separate pedestrians on street sidewalks from commercial operations;
- Transit stops that are not easily accessible from primary pedestrian routes;
- Auto-oriented retail centers; and
- Long blocks that discourage walking.

Policy 2.3-5 Design pedestrian nodes to be open and eliminate potential hiding places to deter crime and promote safety. A conceptual design of a pedestrian node is shown on Figure 2.3-5, *Conceptual Pedestrian Node Plan* and Figure 2.3-6, *Conceptual Trellis Elevation*.

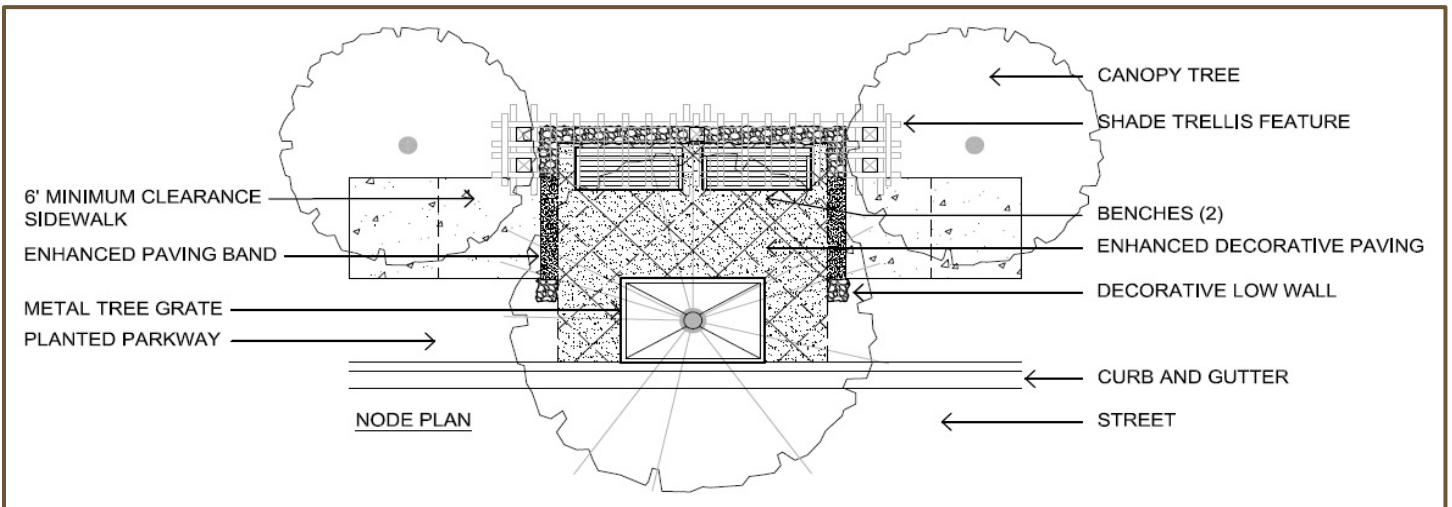

Figure 2.3-5 *Conceptual Pedestrian Node Plan*

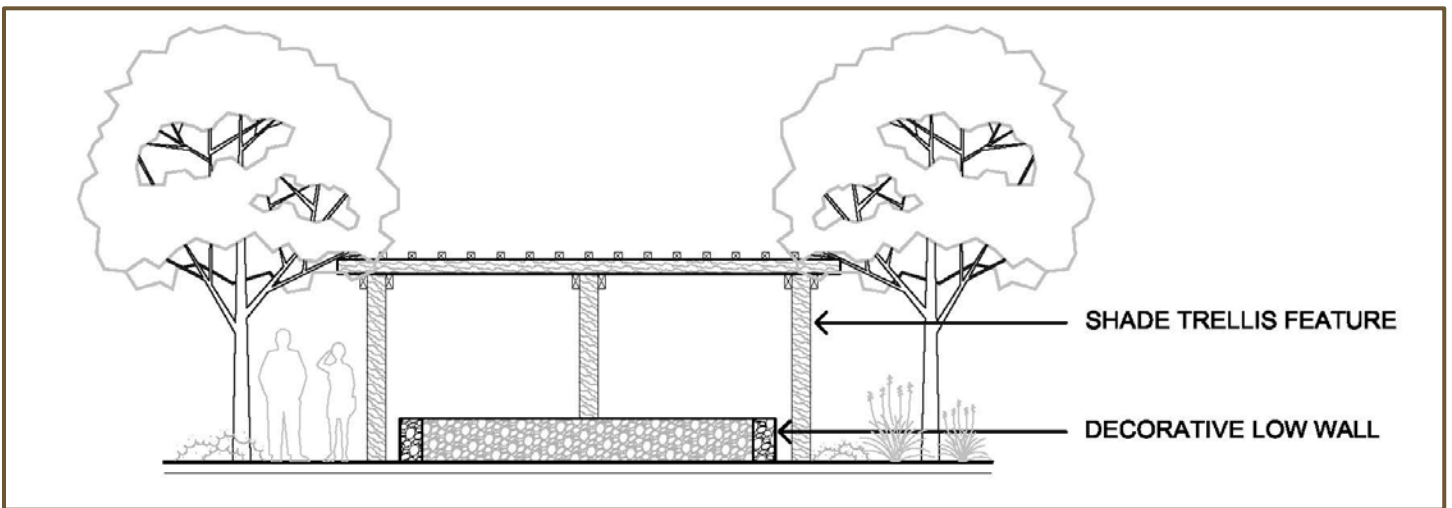

Figure 2.3-6 *Conceptual Trellis Elevation*



Policy 2.3-6 Design and locate pedestrian improvements to achieve the maximum benefit for their cost, including the initial cost of construction and ongoing maintenance.

Policy 2.3-7 Minimize cross-circulation between vehicles and pedestrians. Provide a clearly marked walkway between parking areas and main entrances of buildings.

Policy 2.3-8 Design pedestrian linkages to be free of safety hazards. Walking surfaces should be firm and stable, durable, and slip-resistant, level, and wide enough to allow two people to comfortably pass when walking in opposite directions.



Mid-block crossings provide safe pedestrian crosswalks between intersections.

Policy 2.3-9 Design the grid network so that demand for pedestrian street crossings will occur at intersections to the extent feasible, rather than mid-block. Where necessary to maintain a grid network of non-vehicular mobility facilities within the CENTRAL VILLAGE, mid-block crossings may be allowed provided adequate safety provisions (traffic calming, marked crosswalks, etc.) are incorporated into the mid-block crossing design and the provisions of Council Policy 200-07 are followed, to the satisfaction of the City Engineer. All mid-block crossings must be illuminated at night and aligned with logical pedestrian travel patterns. Blocks in the CENTRAL VILLAGE are envisioned to be short, so pedestrian-only traffic control signals at midblock locations are discouraged except where necessary to maintain an interconnected, grid-patterned non-vehicular mobility system.

Policy 2.3-10 Incorporate traffic calming measures at intersections with pedestrian crossings.

Policy 2.3-11 Implement curb extensions on roadways with on-street parking, as feasible.

Policy 2.3-12 Provide adequate, pedestrian-scaled lighting along all walkways.

Policy 2.3-13 Locate wayfinding signs where appropriate along trails to provide visual cues to trail users.

Policy 2.3-14 Design trails to include major gateways and intersections to enable trail users to connect to other segments of the on-site pedestrian network.

Policy 2.3-15 Design trails within the Multi-Habitat Planning Area (MHPA) to be consistent with the Multiple Species Conservation Program (MSCP) and trail standards and design policies of the City of San Diego's Park and Recreation Department's Consultant's Guide to Park Design and Development.

Policy 2.3-16 Trails within the CENTRAL VILLAGE should likely be maintained by the Master Homeowners' Association, or other funding mechanisms deemed appropriate such as an individual homeowners' association or a Maintenance Assessment District, and should allow for public access.

Policy 2.3-17 Trails are encouraged to be used for Low Impact Development (LID) measures where feasible.

Policy 2.3-18 Locate trailheads at trail access points. As shown on Figure 2.3-4, *Alternative Transportation Plan*, trailheads are located at major trail intersection points to the perimeter trail.

Policy 2.3-19 Provide amenities within trailhead areas that create a comfortable pedestrian environment and social atmosphere. Features may include informational kiosks with trail maps, benches, picnic tables, educational signage, parking, bicycle racks, shade pavilions, and public art.

Policy 2.3-20 Design trail amenities to minimize their impact on adjacent environmentally sensitive areas.

Policy 2.3-21 As suggested by the Otay Mesa Community Plan, trailheads in CENTRAL VILLAGE may be designed using natural material and native plant species to blend trailheads into the natural surroundings. A conceptual design of a trailhead within CENTRAL VILLAGE is shown on Figure 2.3-7, *Trailhead Signage Concept*.

Policy 2.3-22 Trailhead kiosks should be provided where feasible, and may include a map of the trail systems, difficulty, description of each trail segment, safety information, and information on trail etiquette to reduce conflict between different trail users, such as pedestrians, pet owners, and bicyclists.

Policy 2.3-23 The plant palette within pedestrian connection areas consists of attractive, drought tolerant, and low maintenance species. Landscaping treatment within these areas should be consistent with the village-wide plant palette (refer to Table 2.5-2, *Village-Wide Plant Palette*).



Example of trailhead signage appropriate for the CENTRAL VILLAGE.



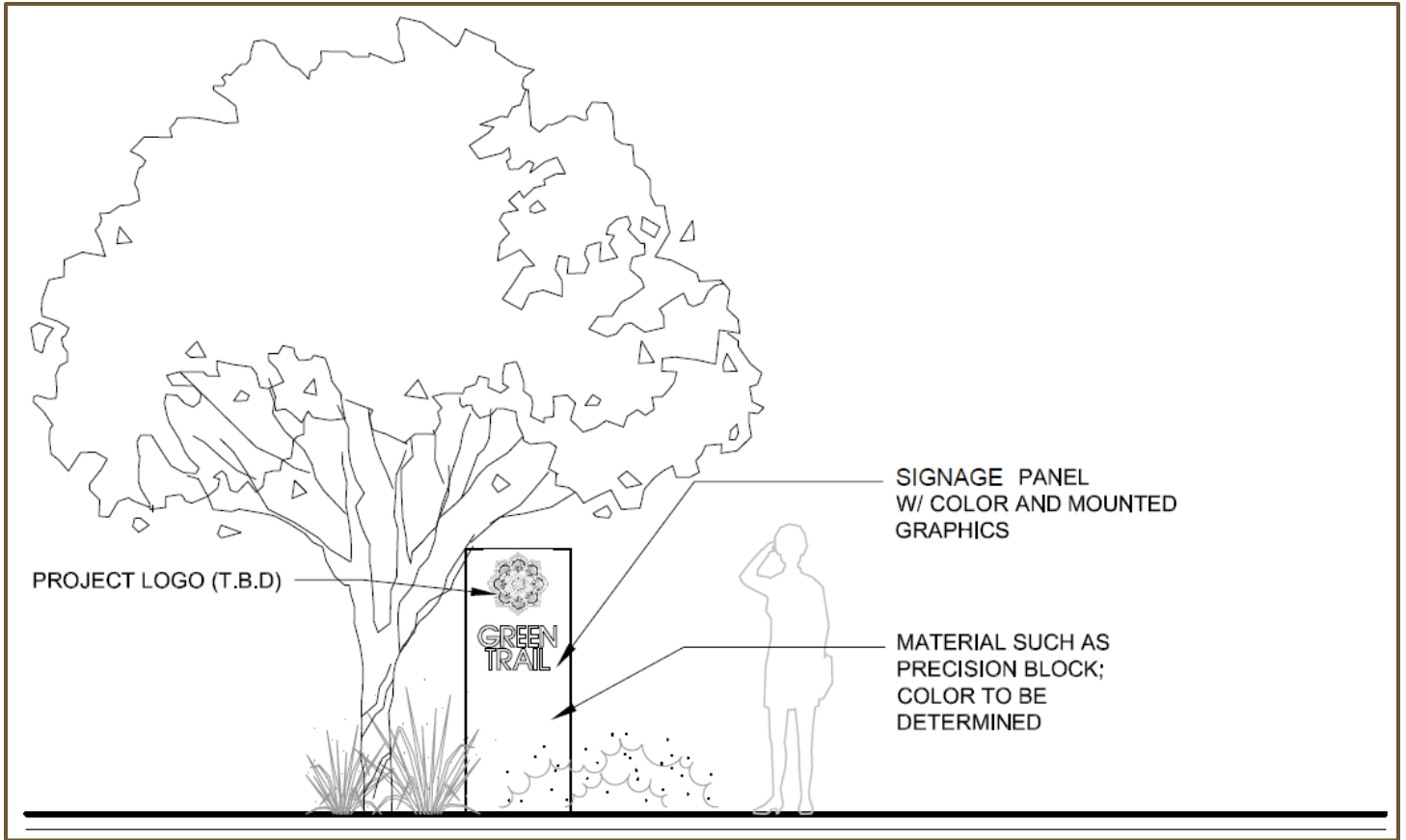

Figure 2.3-7 Trailhead Signage Concept

2.4 PARKS AND OPEN SPACE ELEMENT

The CENTRAL VILLAGE parks and open space system is thoughtfully planned to provide residents with convenient access to a variety of outdoor recreation and social activities in community gathering areas.

2.4.1 PARKS

2.4.1.1 Public Parks Overview

As shown on Figure 2.4-1, *Parks and Open Space Plan*, there are four public parks within the CENTRAL VILLAGE: Village Park, Village Central Park, Vista Park, and Trails Park. These parks are linked together through a system of paseos, pedestrian nodes, trails, and Green Streets. All parks would be deeded to the City for ownership and maintenance. Each park contains amenities to accommodate the diverse needs and desires of community residents and reinforce the aesthetic character of CENTRAL VILLAGE. A cohesive system of paseos, pedestrian nodes, and trails connect these parks with each other and other community destinations to provide safe and direct access to the parks and serve as the “connective fabric” of CENTRAL VILLAGE.

Buildout of the CENTRAL VILLAGE would result in a projected population of 15,473 residents. Based on the Otay Mesa Community Plan standard of 2.8 net useable acres per 1,000 population, 43.3 acres of parkland would be required for the residents of the CENTRAL VILLAGE. A total of 16.1 acres of parkland are proposed in the four neighborhood parks, as described below. The remaining 27.2 acres of parkland are located in Grand Park. Grand Park is located outside of the CENTRAL VILLAGE area at the southeast corner of Airway Road and Cactus Road, and is designed to be utilized by the Otay Mesa Community as a whole. The Grand Park is envisioned as a link between villages, the surrounding employment centers, and education institutions, and enhances the connectivity of the Airway Road transit corridor. Grand Park is approximately 36 acres in size, and 8.1 acres have already been allocated to other future developments in the Central and Southwest Districts. Thus, approximately 27.9 acres are available at Grand Park to meet the 27.2 acres of parkland requirement for the CENTRAL VILLAGE. In the event that Planning Area 14 is not developed with school/recreation uses, Planning Area 14 may instead be developed with up to 197 MD Multi-Family homes. In such a case, the total number of dwelling units allowed within the CENTRAL VILLAGE shall increase to 4,682 units, and if fully built, result in a future population of approximately 16,153 people. Any population-based park requirements for future residential development

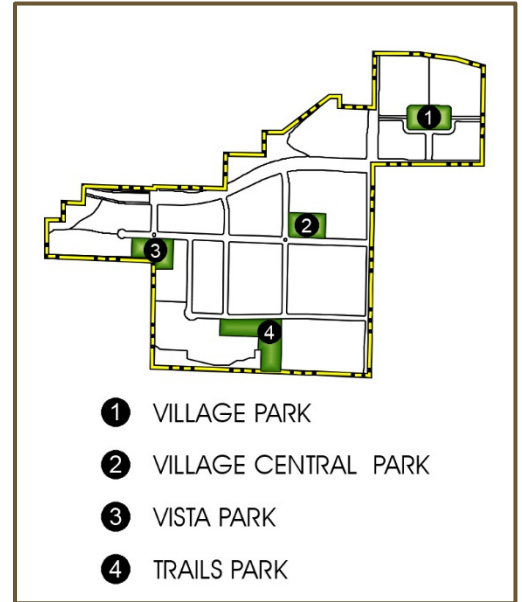

Park Location Map.



within Planning Area 14 shall be met on-site within Planning Area 14, or elsewhere within the CENTRAL VILLAGE.

Descriptive concept plans and representative photographs of each park are provided below. All photographs and concept plans are for illustrative purposes only, and are intended to provide guidance for future park amenities while also allowing for flexibility at implementation. The conceptual park plans serve to represent programmatic elements within each park. Final park design may vary and will not require an amendment to this Specific Plan. Final park names may be determined during the public input design process. These parks address a portion of the CENTRAL VILLAGE’S population-based park requirements in accordance with City requirements. Therefore, development of park space within CENTRAL VILLAGE shall follow **Council Policy 600-33, “Community Notification and Input for City-Wide Park Development Projects,”** which requires a public input process in accordance with City requirements.



Village Park may include a central focus point, shaded seating areas, children’s play areas, tot lots, and turf play areas.



Village Central Park can provide opportunities to socialize and relax.

Village Park: The 3.5-acre Village Park is a neighborhood park located in the northeast portion of the CENTRAL VILLAGE in Planning Area 17 (see Figure 2.4-1). Village Park is surrounded by multi-family residential development to the north and southeast, with mixed use and multi-family development to the southwest. The park provides opportunities to play, socialize, and relax through a variety of programmatic elements. The location of the park is optimum for neighborhood-level recreational opportunities due to its central and highly visible location amongst residential areas.

Village Central Park: The 3.1-acre Village Central Park is located in the central portion of CENTRAL VILLAGE in Planning Area 16 (refer to Figure 2.4-1), adjacent to mixed use and multi-family areas and the school site. The Village Central Park serves as the “village core,” which is intended to reflect a village plaza or town square character. The Village Central Park is planned as a central gathering place where local community events, concerts, and shows may take place. The surrounding commercial uses work to enhance the park’s synergy by drawing people into the area and allowing for a constant flow of users through the CENTRAL VILLAGE core. Given its location and function, this park is expected to be the most social among the four featured parks.

Vista Park: The 3.5-acre Vista Park is located along the western edge of the CENTRAL VILLAGE in Planning Area 15 (see Figure 2.4-1). Given its location, Vista Park provides a visual connection to regional open space areas and offers panoramic views and distant views of the ocean. The park’s location

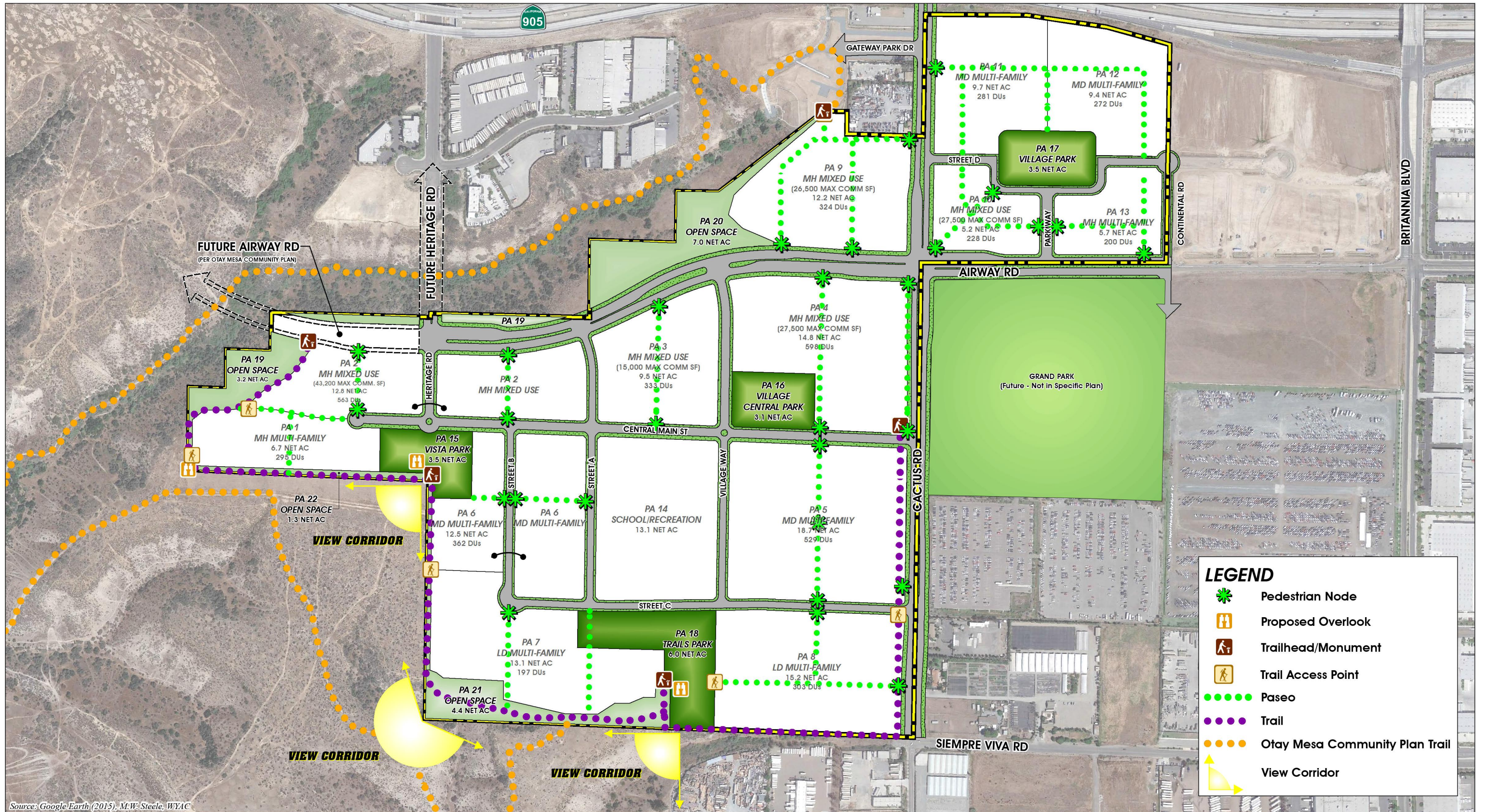

Source: Google Earth (2015), M.W. Steele, WYAC

Figure 2.4-1

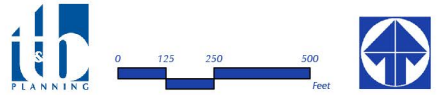

PARKS AND OPEN SPACE PLAN



This page intentionally left blank.

provides a unique opportunity for several passive and recreational activities and amenities.

Trails Park: The 6.0-acre Trails Park is located in Planning Area 18, just south of the school site (see Figure 2.4-1), and provides for active and passive recreational uses. Trails Park may feature an organic character through the use of natural design elements that emphasize overlooks to surrounding open space areas.

2.4.1.2 Parks Standards and Policies

The following design standards and policies apply to park facilities throughout the CENTRAL VILLAGE.

A. General Park Design Standards and Policies

Design Standard 2.4-1 Parkland improvements within Planning Areas 15, 16, 17, and 18 shall be constructed concurrent with the residential uses they are intended to serve. Trail improvements shall be implemented concurrent with development of adjacent planning areas.

Design Standard 2.4-2 Population-based park land shall be rezoned; however, rezoning of these areas shall occur in concert with the public park development process, and at that time, these areas shall be dedicated to the City.

Design Standard 2.4-3 Park design within the CENTRAL VILLAGE shall be sustainable, utilize drought tolerant plant materials, and be consistent with the village-wide plant palette (refer to Table 2.5-2).

Design Standard 2.4-4 The ground floor in buildings abutting parks shall be occupied by active uses (such as residential and commercial uses). The ground floor in buildings abutting parks shall not be the rear of the building.

Design Standard 2.4-5 Park boundaries may be adjusted as necessary to ensure implementation of the parks, provided that: a) the resulting useable acreage shall not be less than what is stipulated by this Specific Plan, and b) the location shall remain in close proximity to the Planning Areas shown on this Specific Plan (refer to Figure 2.2-1). Any such action would require a rezone.

Design Standard 2.4-6 Of the 13.1 net acres within Planning Area 14, it is estimated that the San Ysidro School District may need approximately 10.0 net acres for development of an elementary school. The remaining 3.1 net acres within Planning Area 14 may be used for private recreation facilities, subject to approval by the Director of Developments Services or his/her designee.



A combination of hardscape and landscape elements may be used to design flexible recreational and social areas.



In addition, the following design policies apply to parks within the CENTRAL VILLAGE:

Policy 2.4-1 The design of parks should be integral to the design of adjacent building frontages. Commercial building frontages should include outdoor seating areas and plazas that front parks. Residential building frontages should include direct access to adjacent parks and provide balconies overlooking the parks for added visual security.

Policy 2.4-2 Buildings that abut and frame parks should have special design consideration in order to create attractive facades, architectural features, articulation, and an inviting pedestrian experience.

B. Village Park Policies

Policy 2.4-3 Design Village Park to provide a mixture of neighborhood-serving amenities to serve groups and individuals, such as active and passive recreational areas for all ages.

Policy 2.4-4 Locate open lawn areas and neighborhood gathering areas and activity nodes in the central portion of the park. Canopy shade trees may be located along the northern and southern edges of the park to visually strengthen the edges of the park. Informal groupings of accent trees may be used to enhance the eastern and western sides of the park. A concept plan of Village Park is provided on Figure 2.4-2, *Village Park Concept Plan*.

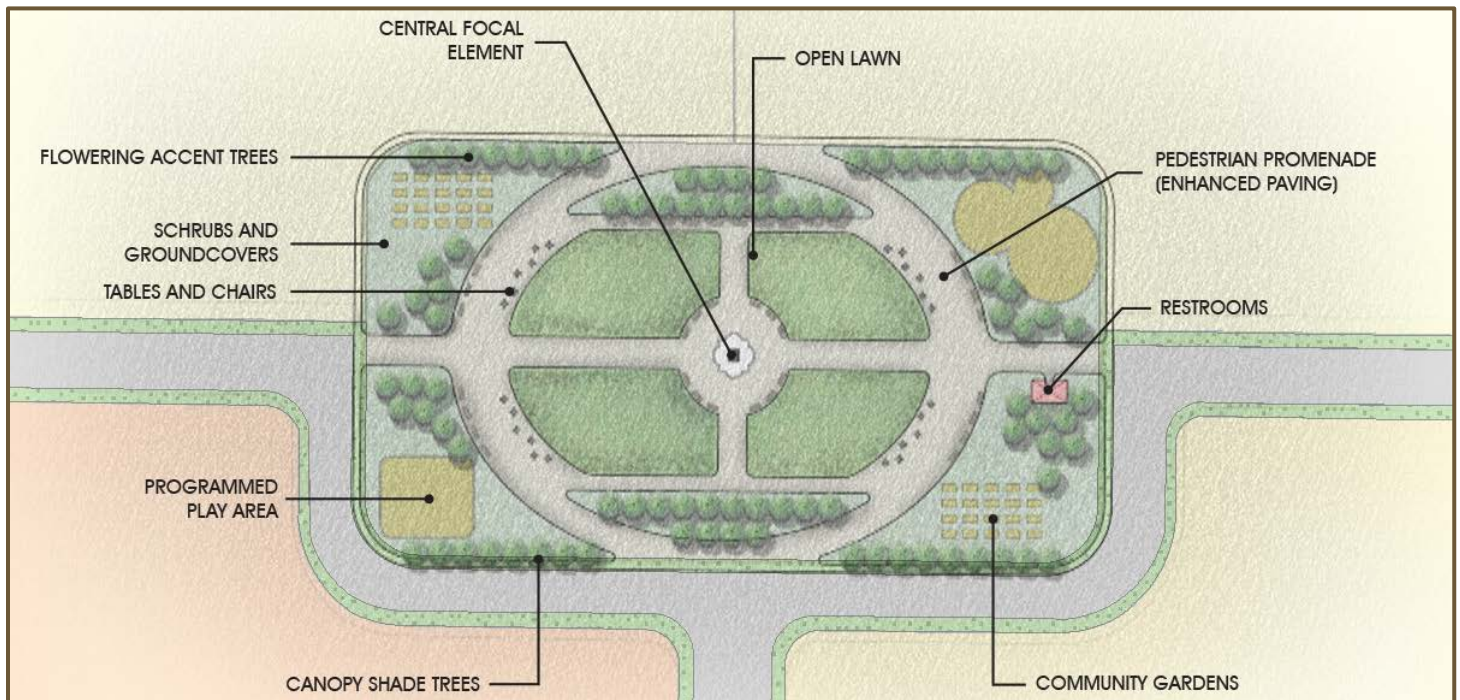

Figure 2.4-2 Village Park Concept Plan

Policy 2.4-5 A highly visible landmark element may be used as Village Park's focal point to enhance the park's identity.

Policy 2.4-6 Park amenities should be consistent with the adjacent land use; for example, residential edges should contain residential amenities such as tot lots, and commercial edges should include commercial amenities such as outdoor plazas.

C. Village Central Park Policies

Policy 2.4-7 Design Village Central Park to have a town square character by providing a central gathering area.

Policy 2.4-8 Incorporate a combination of formal and naturalistic hardscape and landscape elements to provide flexible recreation spaces that may be used for a variety of activities.

Policy 2.4-9 A highly visible landmark element may be used as Village Central Park's focal point to enhance the park's identity.

Policy 2.4-10 Provide amenities that facilitate social interaction such as low seating walls, picnic areas, and table seating.

Policy 2.4-11 Incorporate open turf areas to allow for multi-use games and events.

Policy 2.4-12 Define the park space by placing accent and canopy trees around the edges of the park to enhance the aesthetics and attractiveness of the facility and provide a buffer from adjacent streets.

Policy 2.4-13 Provide shade in areas for seating, gathering, and picnicking by locating trees and/or shade structures around and within these areas. A concept plan for Village Central Park is provided on Figure 2.4-3, *Village Central Park Concept Plan*.

D. Vista Park Policies

Policy 2.4-14 Design Vista Park to provide a combination of passive and recreational amenities, which may include interpretive signs providing information on the cultural resources and habitat of the adjacent open space and canyon areas, shaded areas for sitting and relaxing, multi-purpose fields for pick-up games and sport activities, and exercise courses.

Policy 2.4-15 Integrate a viewing area into the southern portion of Vista Park to take advantage of the open space and canyon views to the southwest.

Policy 2.4-16 Provide connections and trail heads to existing trails within adjacent open space areas.



Village Central Park may be designed to have a town square character.



Vista Park may include a programmed play area.



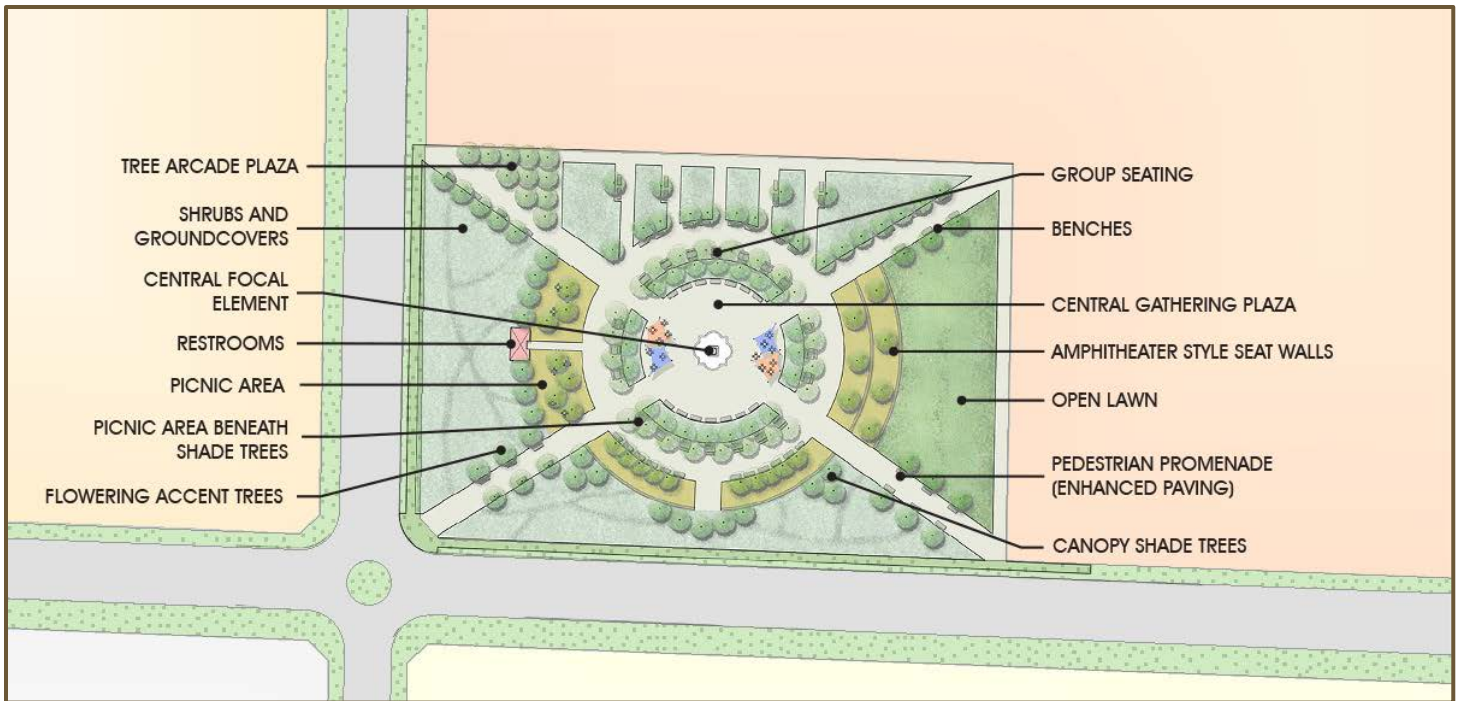

Figure 2.4-3 Village Central Park Concept Plan

Policy 2.4-17 Incorporate drought-tolerant plant materials throughout Vista Park that provide a transition to the adjacent open space area. A concept plan of Vista Park is provided on Figure 2.4-4, *Vista Park Concept Plan*.

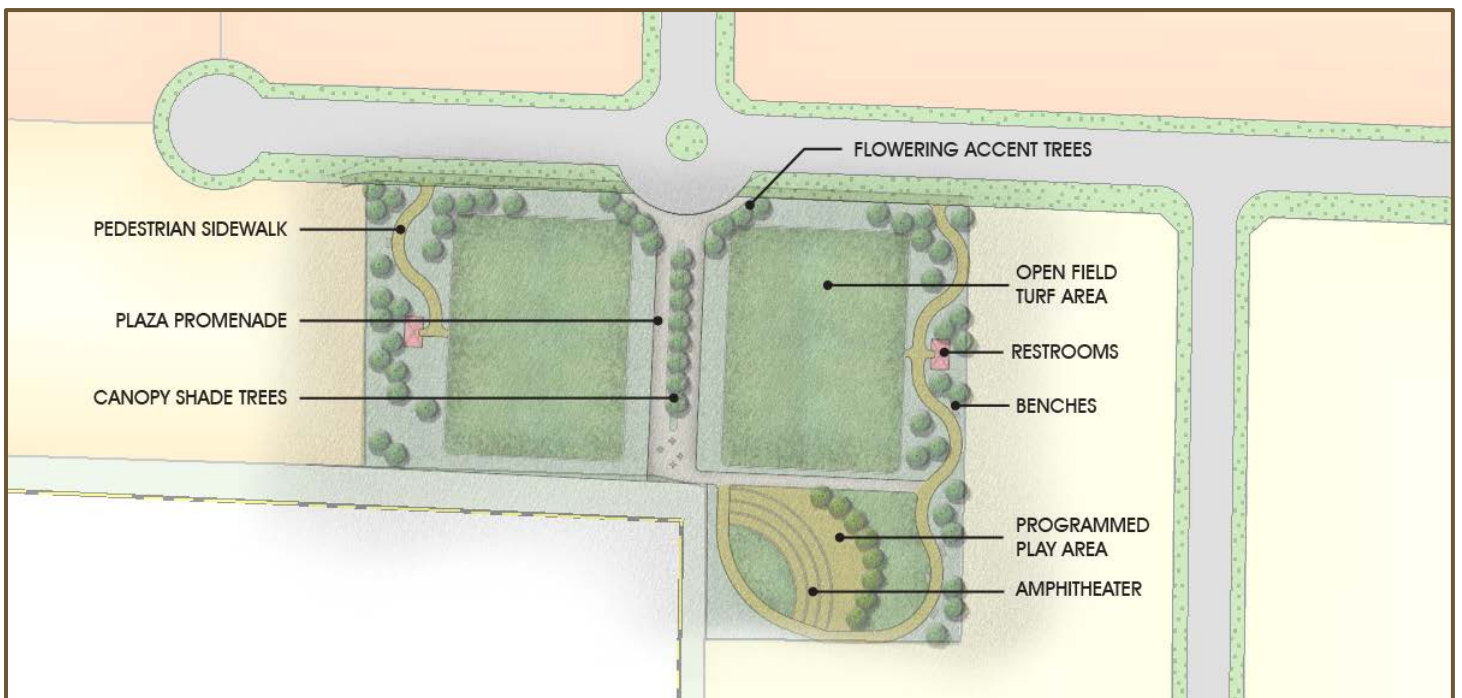

Figure 2.4-4 Vista Park Concept Plan

E. Trails Park Policies

Policy 2.4-18 Incorporate natural design elements into Trails Park, such as drought-tolerant landscaping to enhance the park’s organic character and its connection to adjacent open space areas.

Policy 2.4-19 Provide a system of meandering pedestrian paths and walkways in Trails Park that link to the existing trails system.

Policy 2.4-20 Feature educational amenities, which may include interpretive signs along pathways with information on cultural resources and habitat.

Policy 2.4-21 Provide active and passive recreational uses, such as children play areas, multi-purpose fields that could be programmed for leagues use, and walking tracks.

Policy 2.4-22 Plant drought-tolerant landscaping that blend the park’s edges adjacent to the existing open space areas.

Policy 2.4-23 Plant canopy trees to provide shade and define the park design. A concept plan of Trails Park is provided on Figure 2.4-5, *Trails Park Concept Plan*.



Trails Park may include a system of meandering pedestrian paths.



Trails Park may include a shaded overlook area.



Figure 2.4-5 Trails Park Concept Plan





Spring Canyon.

2.4.2 OPEN SPACE

Spring Canyon is located adjacent to the northern, western, and southern boundaries of the CENTRAL VILLAGE and is one of the two open space networks located within Otay Mesa. Spring Canyon is located south of SR-905 and consists of a series of long finger canyons, with expansive mesas that provide spectacular views of the canyon areas. Spring Canyon serves as an important wildlife and MHPA biological preserve and provides several natural drainage systems that flow into the Tijuana River. Open space areas within CENTRAL VILLAGE are part of Spring Canyon and are located in planning areas that abut off-site canyon areas (see Figure 2.2-1). Figure 2.4-6, *Multiple Habitat Planning Areas Surrounding Central Village*, depicts the boundaries of the MHPA areas in relation to the CENTRAL VILLAGE. As shown, a portion of the MHPA boundary occurs within the CENTRAL VILLAGE, within areas planned for long-term conservation as open space as well as within portions of the right-of-way for Airway Road as planned by the Otay Mesa Community Plan.

In addition, open space areas within CENTRAL VILLAGE are consistent with the open space designations applied to the area by the Otay Mesa Community Plan. These areas are designed to preserve existing open space and preclude development.

2.4.2.1 Open Space Design Standards

The following design standards and policy apply to open space areas throughout the CENTRAL VILLAGE.

Design Standard 2.4-7 Where residential uses abut the San Diego MSCP Sub-Area Plan Multi-Habitat Planning Areas (MHPA), appropriate buffers and/or barriers (walls, fencing, etc.) shall be provided in conjunction with implementing development at the edge between developed areas and natural areas in order to preclude intrusion into these areas by people and domestic animals.

Design Standard 2.4-8 Refer to the design standards and policies provided for Brush Management Zones (refer to Section 2.5.3.5) and Natural Slope Plantings (refer to Section 2.5.3.6).

Policy 2.4-24 Trails may be accommodated in open space areas as part of implementing projects. Such trail development shall be subject to any restrictions that may be associated with the Multi-Species Habitat Planning Areas (MHPA) and evaluated pursuant to applicable CEQA requirements in conjunction with the implementing development.

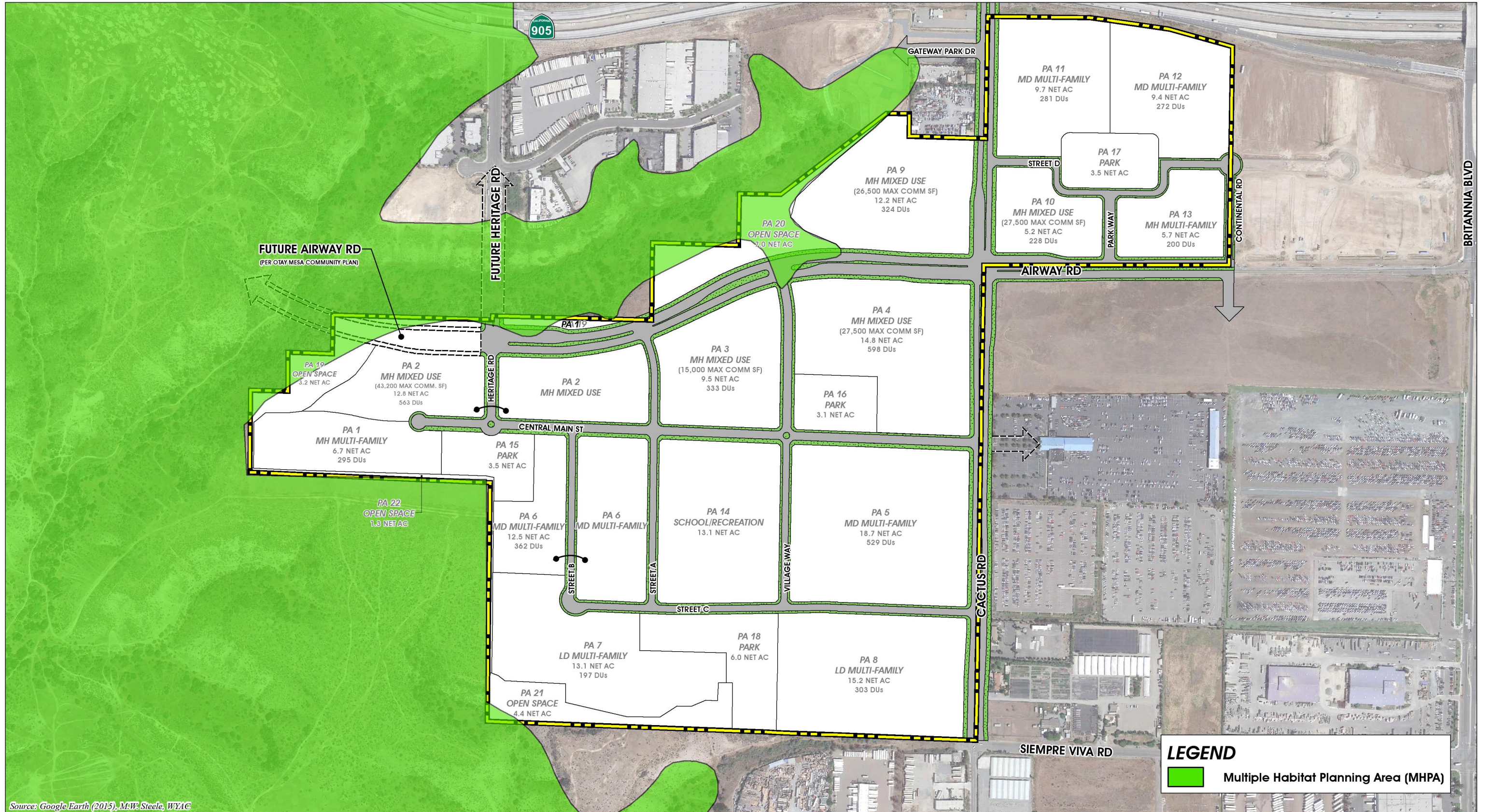

Source: Google Earth (2015), M.W. Steele, WYAC



Figure 2.4-6

MULTIPLE HABITAT PLANNING AREAS SURROUNDING CENTRAL VILLAGE



This page intentionally left blank.

2.5 URBAN DESIGN ELEMENT

This section provides design standards and policies for urban design elements including design principles, architectural design, and landscape design to ensure that implementing development projects are consistent with the design goals of the CENTRAL VILLAGE.

2.5.1 DESIGN PRINCIPLES

The following design principles apply to development throughout the CENTRAL VILLAGE, as called out on Figure 2.5-1, *Design Principals Key Map*. Illustrations and diagrams in this section are conceptual and provided to depict the design envisioned for the CENTRAL VILLAGE. Although design principles shown in this section identify typical locations, these principles may apply in other locations throughout CENTRAL VILLAGE.

Design Principles:

1. *Activity Nodes and Gateways*
2. *Open Space Connections and View Corridors*
3. *Gathering Spaces and Interior Courts*
4. *Clear and Interconnected Circulation*
5. *Parking Internal to Block*
6. *Landscape Buffers as Screening*
7. *Positive Frontage and Connecting Land Use Interfaces*

2.5.1.1 Activity Nodes and Gateways

Activity nodes are logical gathering places that occur at the intersection of thoroughfares, such as at gateways, entries to the development, crossroads, and other types of circulation and view nodes. Activity nodes are encouraged to feature architecture, landscape, and urban design elements that support the congregation of people and shape the public realm.

Figure 2.5-2, *Activity Node and Gateway Intersection at Heritage Road and Airway Road*, and Figure 2.5-3, *Mixed Use Development Clustered Around Gateway Intersection*, found on pages 2.5-5 and 2.5-6, respectively, demonstrate design strategies that would characterize an activity node in any location within the CENTRAL VILLAGE.

Policy 2.5-1 Pedestrian plazas, either within the interior of the development or at building street corners, should be provided where possible to help activate street corners, provide a foreground to building entrances, and/or to serve adjacent uses (such as a retail space, café, or



Gateways to the CENTRAL VILLAGE could be marked by architectural features such as towers.



office use). A conceptual design of a pedestrian plaza is provided on Figure 2.5-4, *Conceptual Pedestrian Plaza Design*.

2.5.1.2 Open Space Connections and View Corridors

The CENTRAL VILLAGE is nestled in the canyon preserves of Otay Mesa, offering several opportunities to enjoy open space amenities. As shown on Figure 2.2-1, *Specific Plan Land Use Plan*, Vista Park, and Trails Park are located adjacent to open space areas and provide a visual and physical connection to expansive views and existing and planned trails.



Views of the canyon areas that border CENTRAL VILLAGE should be preserved where possible.

Figure 2.5-5, *Mixed Use Development Adjacent to Park and Canyon Open Space*, demonstrates design strategies that would establish open space connections and view corridors in any location within the CENTRAL VILLAGE.

Policy 2.5-2 Orient entries of buildings to open space areas wherever possible to take advantage of open space views.

Policy 2.5-3 Provide public views to open space areas to the north, west, and south at available points along the development edge, such as at the ends of public roadways and around parks.

Policy 2.5-4 To minimize light pollution and reduce energy use, developments should limit the amount of nighttime light that is projected upward and beyond the site and should direct light into high-traffic areas of the development. Arrange lighting in parking areas to prevent direct glare into adjacent dwelling units and onto neighboring uses/properties.

2.5.1.3 Gathering Spaces and Interior Courts

Public common areas where people can gather to rest, socialize, or share amenities are essential to the pedestrian infrastructure in the CENTRAL VILLAGE. Gathering spaces may include community buildings, access to parking and storage, landscaped seating, tot lots, or other congregating facilities.

Figure 2.5-6, *Multi-Family Residential Development with Gathering Spaces*, and Figure 2.5-7, *Typical Paseo Between Residential Buildings*, demonstrate design strategies that would establish gathering spaces and interior courts in any location within the CENTRAL VILLAGE.

Policy 2.5-5 Pedestrian paseos are encouraged in all developments to provide enhanced connectivity and usable open space.

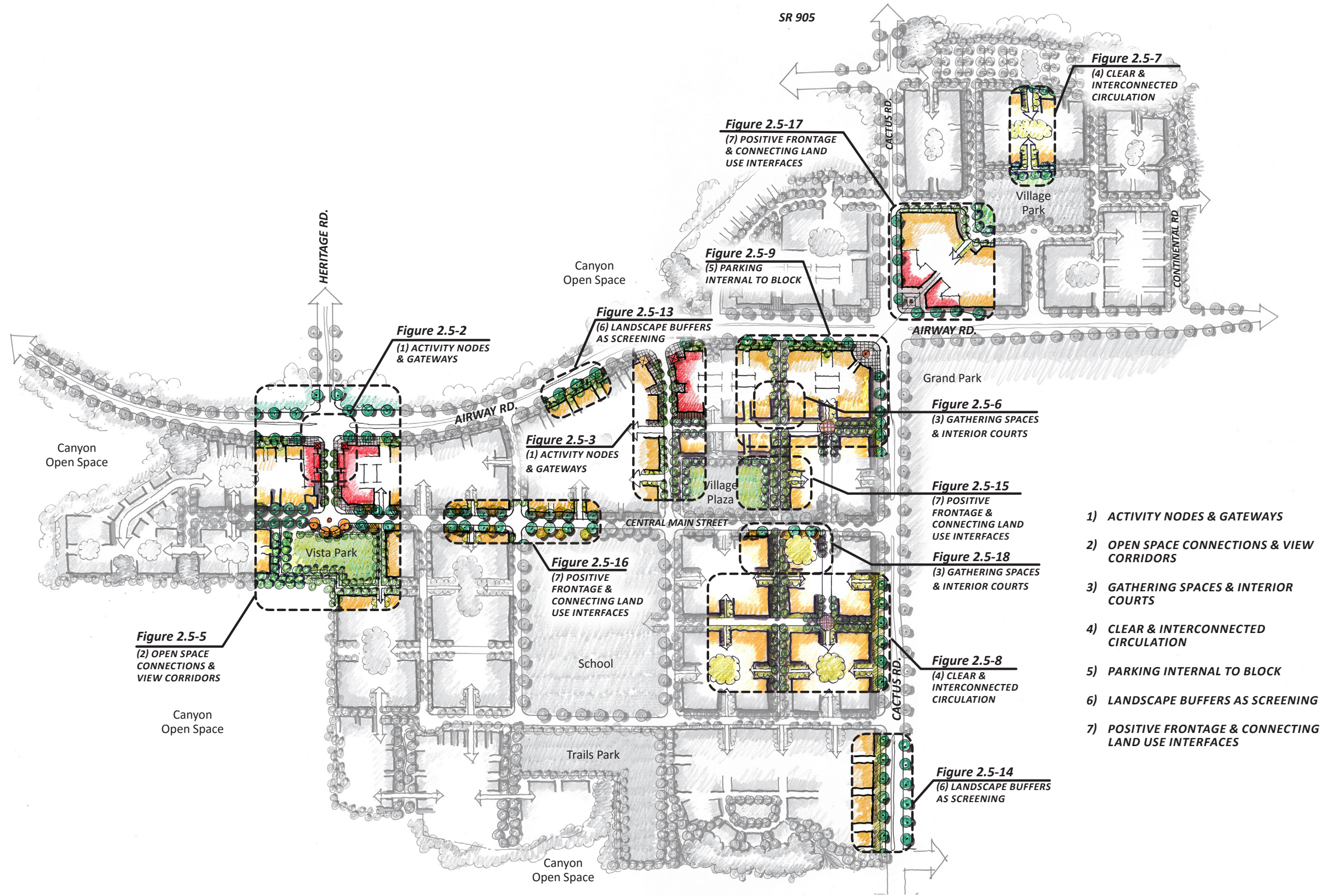

- 1) ACTIVITY NODES & GATEWAYS
- 2) OPEN SPACE CONNECTIONS & VIEW CORRIDORS
- 3) GATHERING SPACES & INTERIOR COURTS
- 4) CLEAR & INTERCONNECTED CIRCULATION
- 5) PARKING INTERNAL TO BLOCK
- 6) LANDSCAPE BUFFERS AS SCREENING
- 7) POSITIVE FRONTAGE & CONNECTING LAND USE INTERFACES

Source: M.W. Steele

Figure 2.5-1

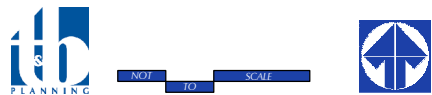

This page intentionally left blank.

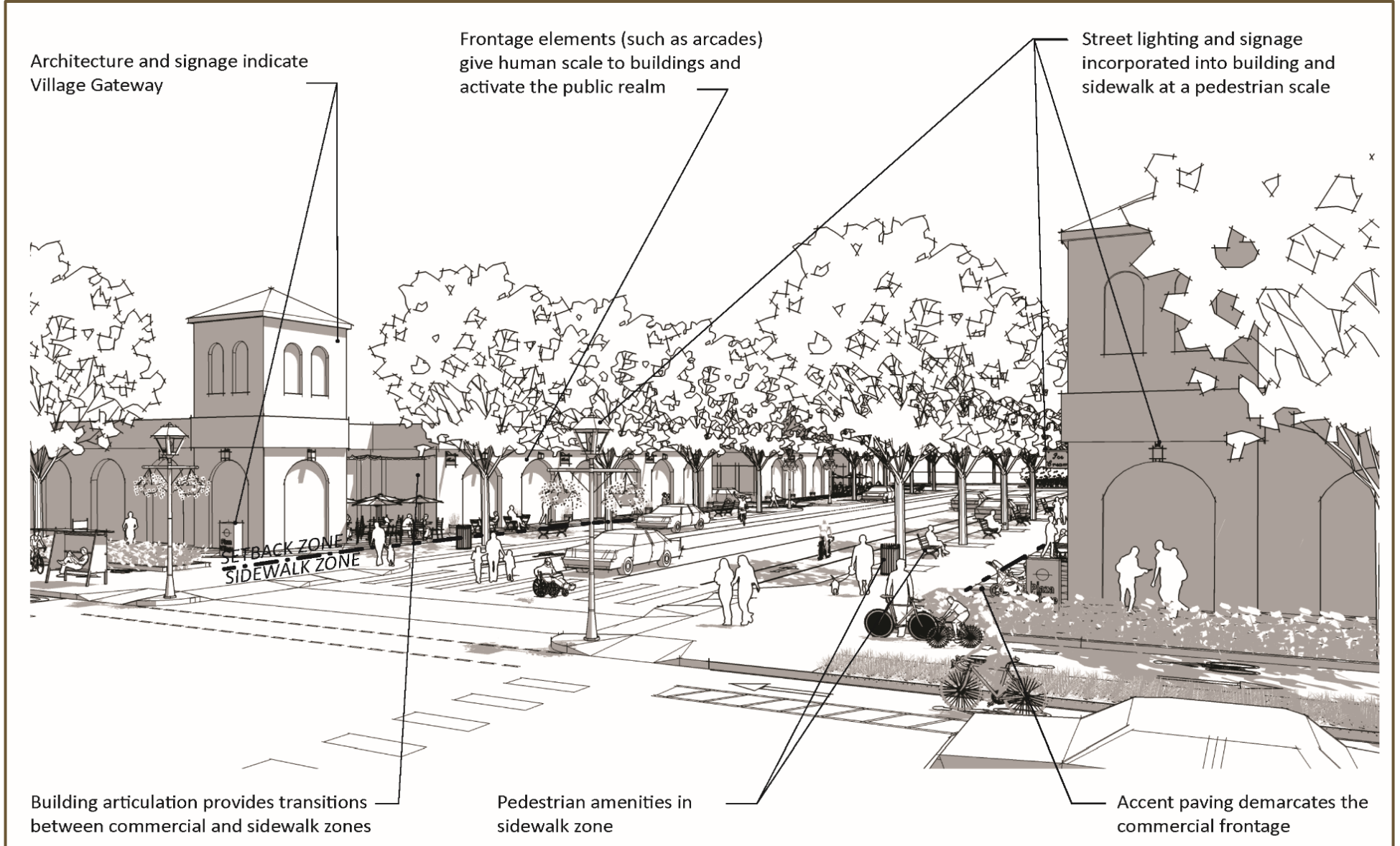

Figure 2.5-2 Activity Node and Gateway Intersection at Heritage Road and Airway Road



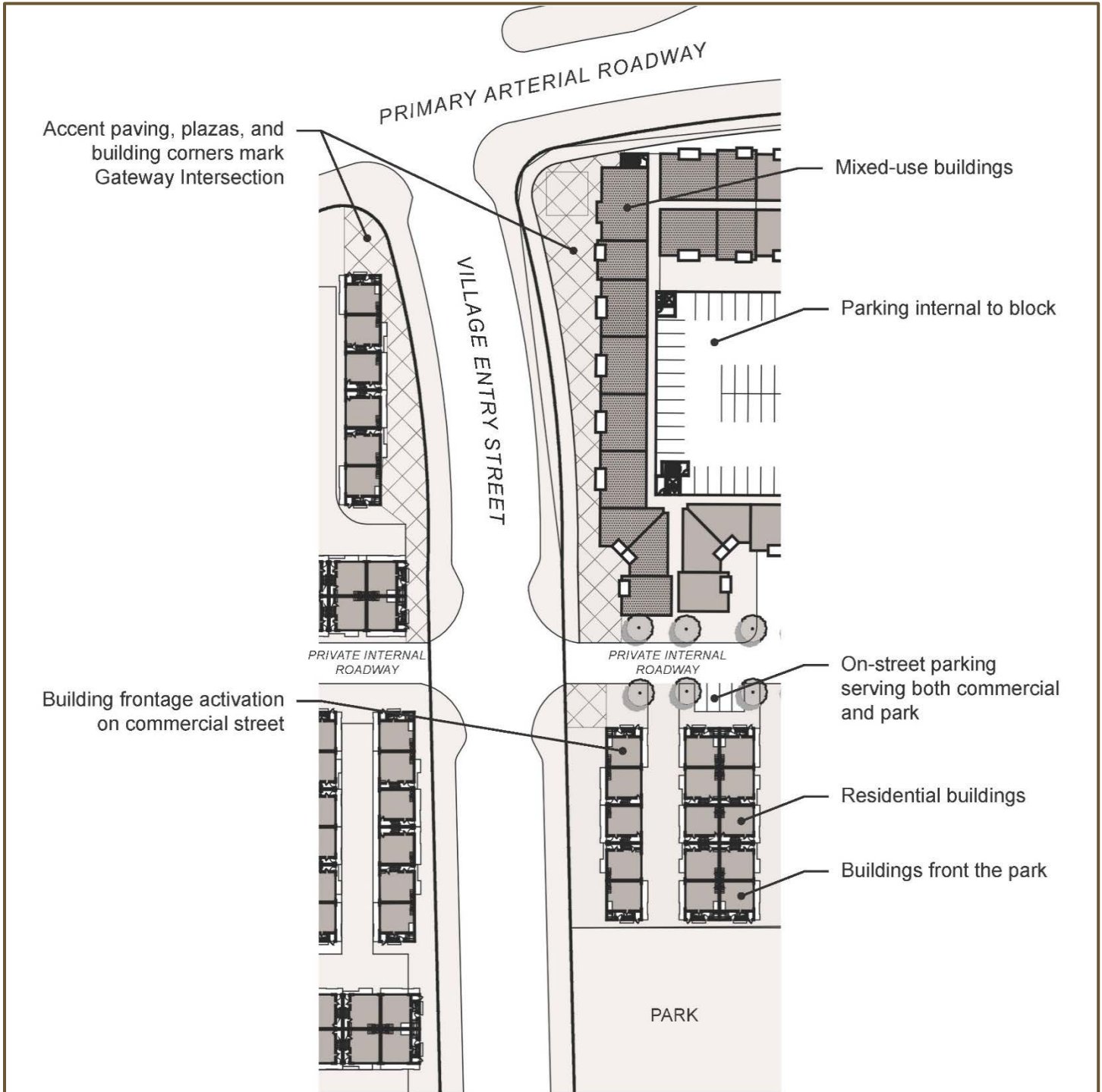

Figure 2.5-3 Mixed Use Development Clustered Around Gateway Intersection

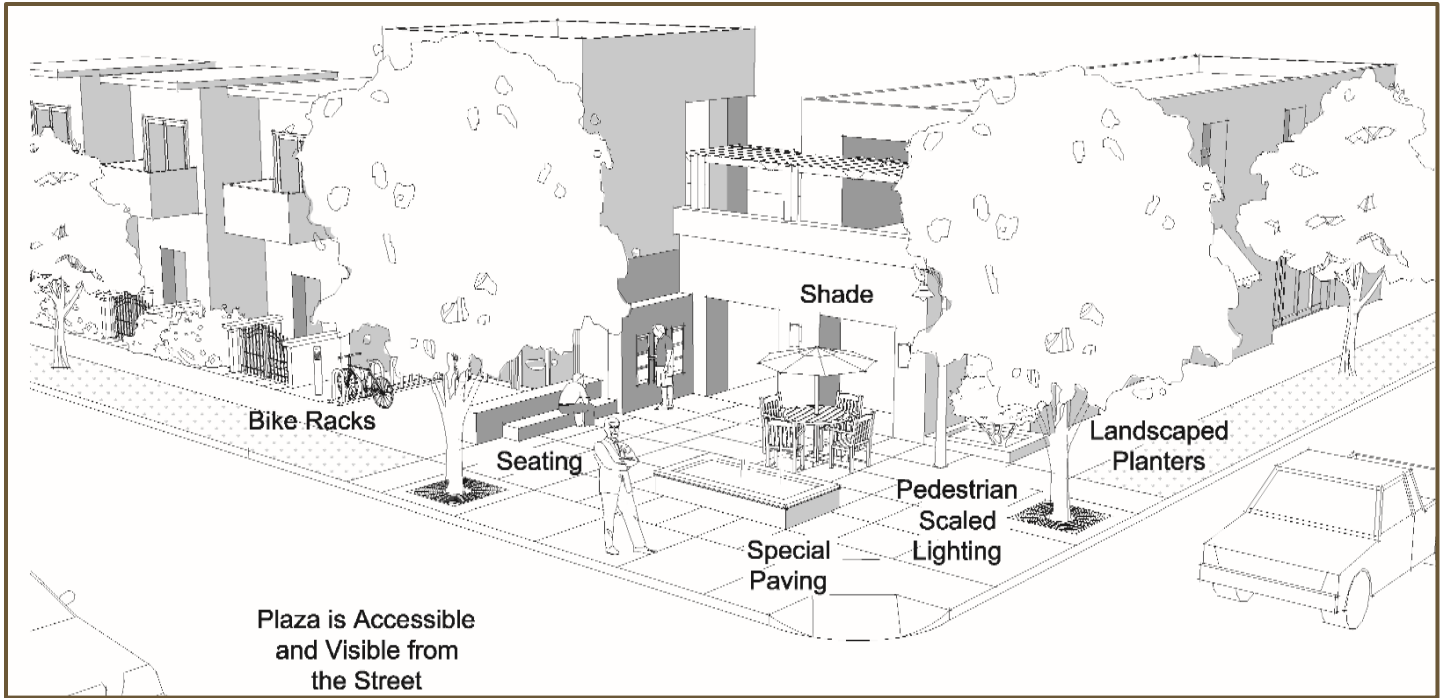

Figure 2.5-4 Conceptual Pedestrian Plaza Design



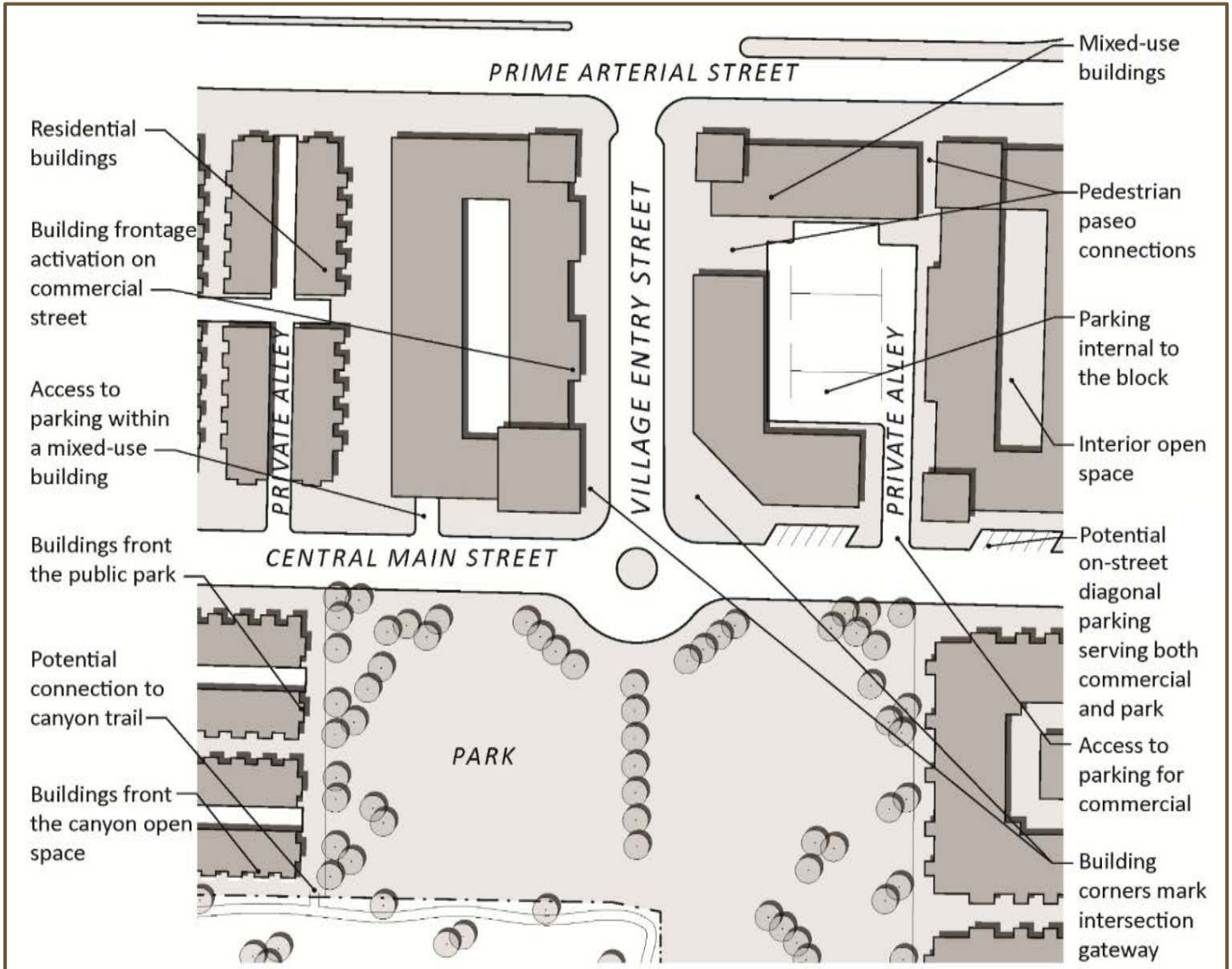

Figure 2.5-5 Mixed Use Development Adjacent to Park and Canyon Open Space

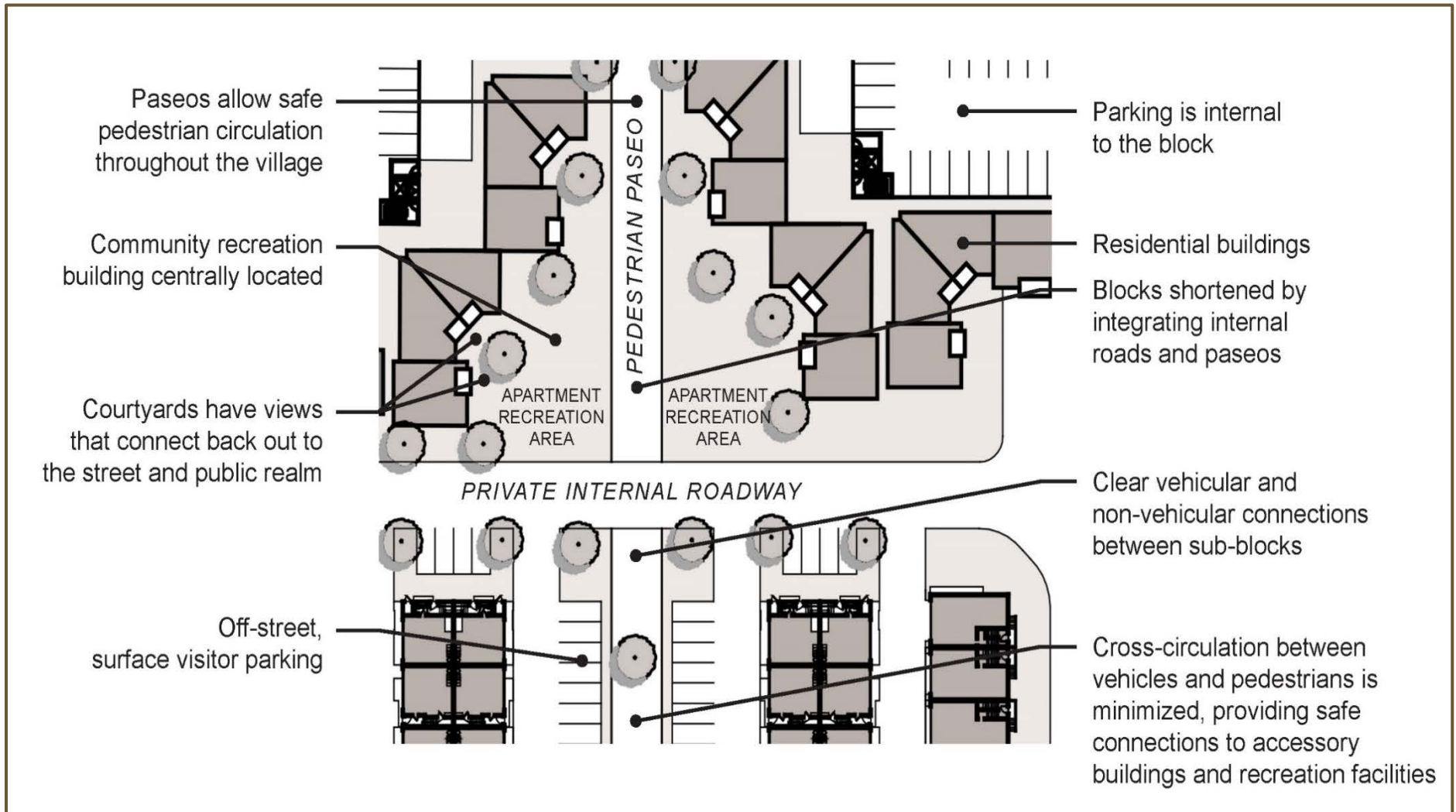

Figure 2.5-6 Multi-Family Residential Development with Gathering Spaces





Figure 2.5-7 Typical Paseo Between Residential Buildings

Policy 2.5-6 Provide outdoor seating areas for passive social activities in appropriate areas for both adults and children. Seating location should consider comfort factors such as sun orientation, shade, and wind.

Policy 2.5-7 Incorporate informal outdoor gathering areas and pedestrian nodes into design plans in ways that allow these spaces to function as community gathering spaces.

Policy 2.5-8 Arrange dwellings, walkways, and common areas to facilitate social interaction among residents through the natural and daily use of the development.

Policy 2.5-9 Design buildings to maximize equal access to daylight, views, open space, and other amenities. Open spaces should be accessible to and conveniently located for the majority of units.

Policy 2.5-10 A series of connected open space areas of varying shape, appearance, and usage are encouraged.

Policy 2.5-11 Make recreation buildings and play areas visible from as many units surrounding them as possible. Direct and convenient access from ground level units to the communal area is encouraged.

Policy 2.5-12 Locate outdoor play areas adjacent to common building facilities, such as a community center, and near pedestrian access points as warranted. Avoid locating play areas near public streets, parking, or entry areas unless physically separated with landscaping.

Policy 2.5-13 Partially cover paved areas with a shade structure and/or trees to minimize their visual impact and reduce the solar heat gain and heat island effect.

2.5.1.4 Clear and Interconnected Circulation

The CENTRAL VILLAGE is envisioned to be a cohesive environment that facilitates mobility within the neighborhood. Multi-modal circulation design is encouraged throughout CENTRAL VILLAGE by providing safe infrastructure for pedestrians and cyclists (see Section 2.3.2). Clear and interconnected circulation for all modes of transit will ensure that the pedestrian network is accessible and well-utilized.

Figure 2.5-8, *Townhomes with Integral Paseo and Pedestrian Network*, demonstrates design strategies that would establish clear and interconnected circulation in any location within the CENTRAL VILLAGE.

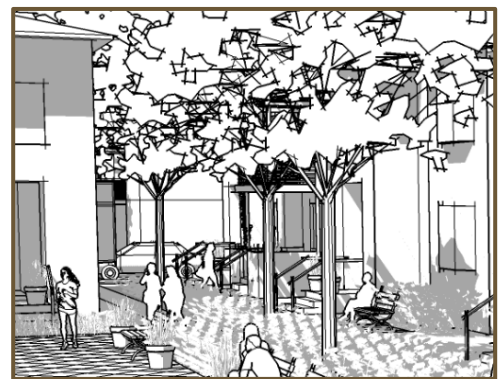

Paseos provide clear and safe pedestrian connections to units from streets and parking areas.



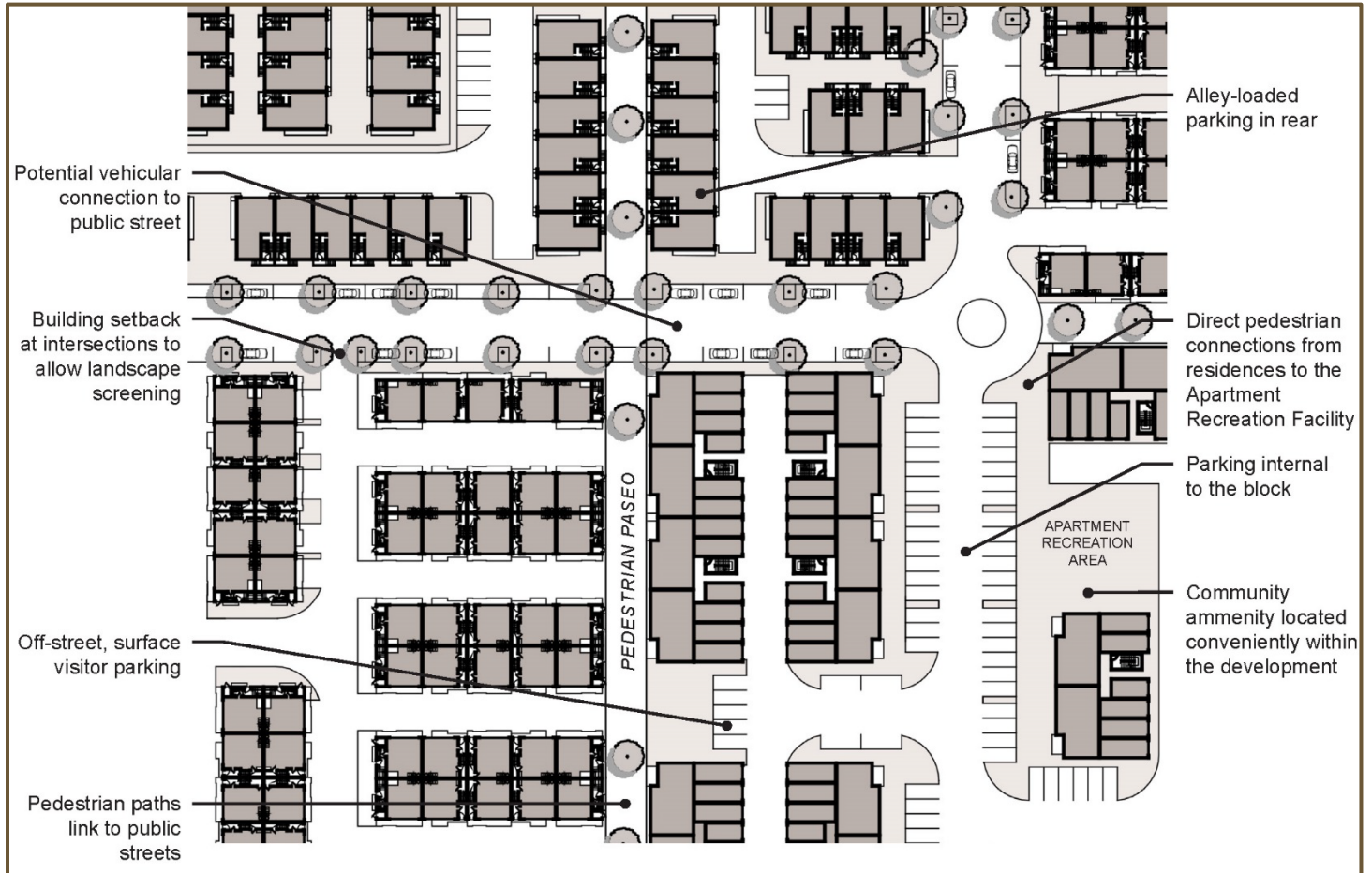

Figure 2.5-8 Townhomes with Integral Paseo and Pedestrian Network

Policy 2.5-14 Orient development in ways that create compact blocks and lots. A ‘block’ is defined as an area of development that is delineated on all sides by public streets, paseos, trails, parks, community facilities, landscaped setbacks, and/or private internal streets. Except where site-specific circumstances preclude it, blocks within the CENTRAL VILLAGE should have a maximum of perimeter of 2,000 feet.

Policy 2.5-15 Design walkways to encourage resident usage and minimize maintenance. To encourage social interaction, pedestrian circulation should be designed to direct residents to communal landscaped areas in route to parking, common areas, and other facilities.

Policy 2.5-16 Developments should incorporate safe pedestrian connections to adjoining residential developments, commercial projects, and open space areas.

Policy 2.5-17 Provide clear and direct vehicular and non-vehicular connections between blocks. This may be accomplished through private streets and drives.

Policy 2.5-18 Minimize cross circulation between vehicles and pedestrians. Provide a continuous, clearly marked walkway from the parking areas to main entrances of buildings.

Policy 2.5-19 Proposed developments should provide an interconnected system of paths, sidewalks, corridors, and walkways that create a safe and pleasant pedestrian environment, connect dwelling units and common areas, are well-integrated with the surrounding neighborhood, and provide multiple pedestrian access points.

Policy 2.5-20 Residential and commercial buildings should provide adequate, accessible, and conveniently located bicycle parking and storage. In addition, development should accommodate bicycle traffic within the village by incorporating bike lanes or wide circulation paths to facilitate bicycle movement throughout CENTRAL VILLAGE.

2.5.1.5 Parking Internal to Block

Public parking within CENTRAL VILLAGE largely consists of on-street parking. On-street parking is provided on both sides of the street along Central Main Street; Park Way; Heritage Road (south of Airway Road); Street D; Continental Road; and along all Residential Collectors and Private Internal Roadways. On-street parking along these streets allows residents and visitors to have safe and direct pedestrian access to key activity nodes and residential neighborhoods throughout the CENTRAL VILLAGE. In addition, parking lots and/or parking garages within mixed use planning areas may be incorporated into the parking design of CENTRAL VILLAGE to accommodate shoppers and visitors.

Private parking within CENTRAL VILLAGE may be provided within mixed use and multi-family areas in the form of parking garages, attached garages, carports, alley parking, and/or parking courts, depending on the residential density of the planning area. To maximize activation of the public realm, on-site parking should be located internal to the block whenever possible.

Figure 2.5-9, *Parking Internal to Mixed Use Development*, demonstrates design strategies that would characterize parking internal to block in any location within the CENTRAL VILLAGE.

The following policies apply to parking.

Policy 2.5-21 Provide for on-street parking in accordance to the widths specified on Figure 2.3-2, *Street Cross-Sections (1 of 2)*, and Figure 2.3-3, *Street Cross-Sections (2 of 2)*.



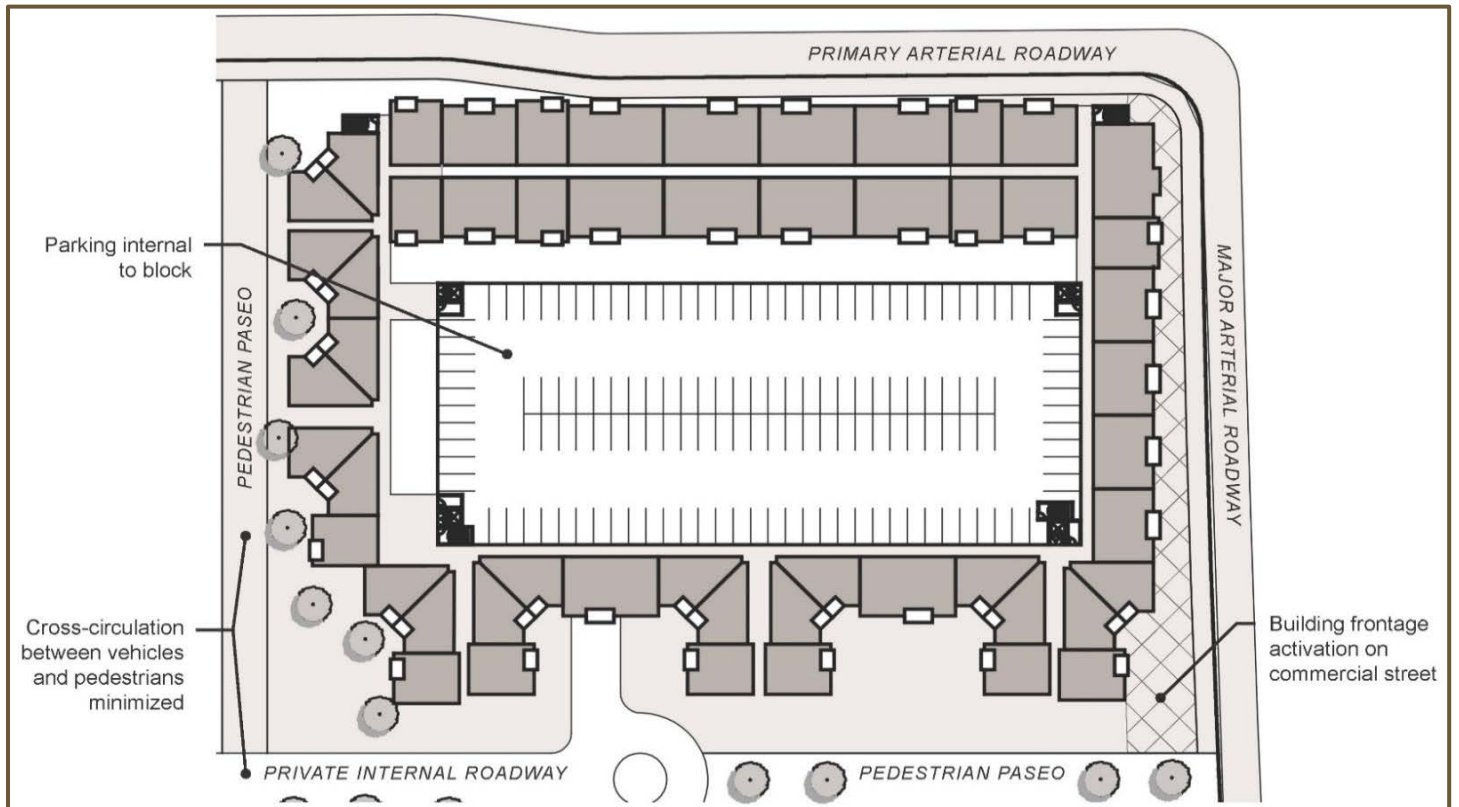

Figure 2.5-9 Parking Internal to Mixed Use Development

Policy 2.5-22 Support shared parking agreements in Mixed Use Planning Areas and other areas of the CENTRAL VILLAGE where shared parking can be supported.

Policy 2.5-23 Designate on-street and off-street parking areas for car-sharing services.

Policy 2.5-24 Allow for unbundled parking, wherein the price to rent or buy a multi-family residential unit or commercial building space is separate from the price to rent or buy associated parking spaces.

Policy 2.5-25 Design parking areas to minimize their visual impact. Where parking areas are necessary, landscape screening is recommended to reduce cars dominating views and minimize a perceived density increase of the development.

Policy 2.5-26 Incorporate landscaped buffers to screen views of surface parking from the street, as conceptually shown on Figure 2.5-10, *Typical Landscape Condition to Screen Street Views to Parking*.

Policy 2.5-27 For security reasons, dwelling units should have sight lines to exterior parking areas. Views should be partially filtered through appropriate landscape elements, such as trees.

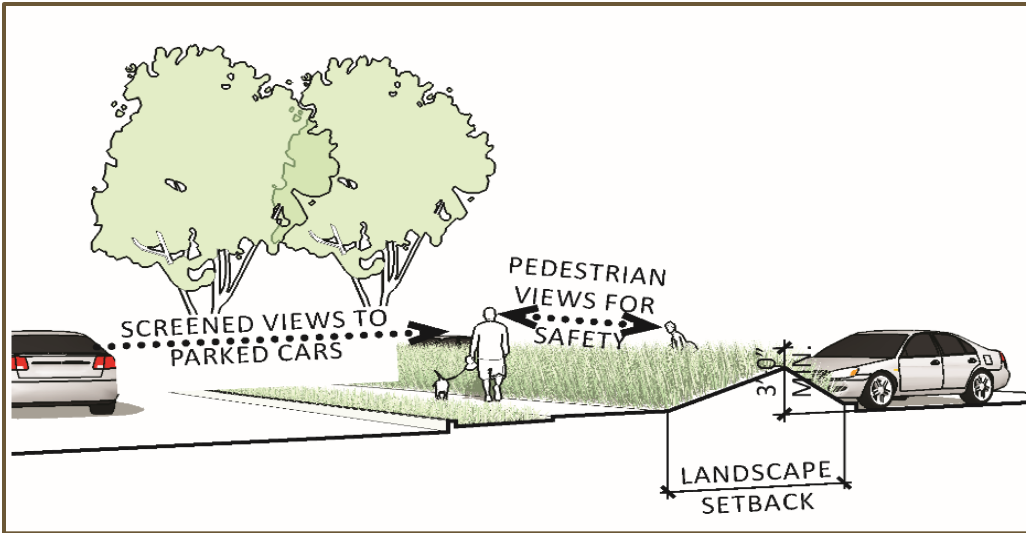

Figure 2.5-10 Typical Landscape Condition to Screen Street Views to Parking

Policy 2.5-28 Provide lighting and landscaped areas around garages, tuck-under parking, and underground parking entrances to provide visual relief and safety.

Policy 2.5-29 Design detached garages, and accessory structures as an integral part of the development's architecture.

Policy 2.5-30 Entry drives to residential developments should have an adjacent pedestrian path.

Policy 2.5-31 Special accents that define the main entrance, create territorial reinforcement, and provide visual interest are encouraged, such as architectural detailing, specialty lighting, signage, enhanced paving, and accent plant materials, such as specimen trees and flowering plants.

Policy 2.5-32 Parking courts should be well designed, with consideration given to landscape, lighting, building massing, and pedestrian/vehicular circulation.

Policy 2.5-33 Vehicle speeds should be controlled by appropriate signage, changes in roadway texture, or speed bumps, if necessary.

Policy 2.5-34 All exterior parking areas should be landscaped at regular intervals with trees and other plantings in median strips, bioswales, or planting boxes consistent with the requirements detailed in the City of San Diego Land Development Code.

Policy 2.5-35 Protect landscape in parking areas from vehicular and pedestrian damage by means of a minimum 6-inch raised planting surfaces or curbs.



Lighting and landscaping provide visual relief by deemphasizing the garage door.



Policy 2.5-36 Use landscaping treatments that are consistent with the village-wide plant palette (refer to Table 2.5-2, *Village-Wide Plant Palette*).

Policy 2.5-37 Provide dedicated pedestrian paths between residential and commercial buildings and parking, as conceptually shown on Figure 2.5-11, *Typical Pedestrian Path Connecting Parking with Commercial Uses*.

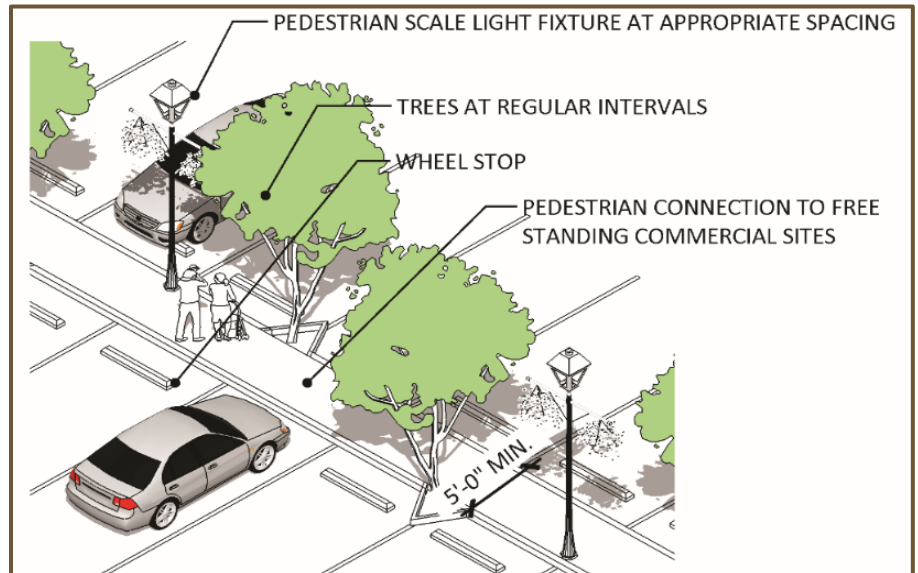

Figure 2.5-11 *Typical Pedestrian Path Connecting Parking with Commercial Uses*

Policy 2.5-38 To provide visual interest and avoid an identical appearance, incorporate architectural detailing into garage doors that is consistent with the overall development's architectural design, such as patterned garage doors, painted trim, or varied garage door colors.

Policy 2.5-39 Use a shade structure and/or trees in parking areas to minimize their visual impact and reduce the solar heat gain and heat island effect produced when sunlight hits asphalt and paved areas.

Policy 2.5-40 Provide a 24-inch box canopy tree within 30-feet of each parking space.

Policy 2.5-41 Incorporate solar arrays into shade structures on uncovered levels of parking structures, where feasible.

Policy 2.5-42 Design parking areas to incorporate landscaping, screening, and pedestrian pathways where appropriate. A conceptual parking design incorporating these elements is shown on Figure 2.5-12, *Conceptual Parking Design*.

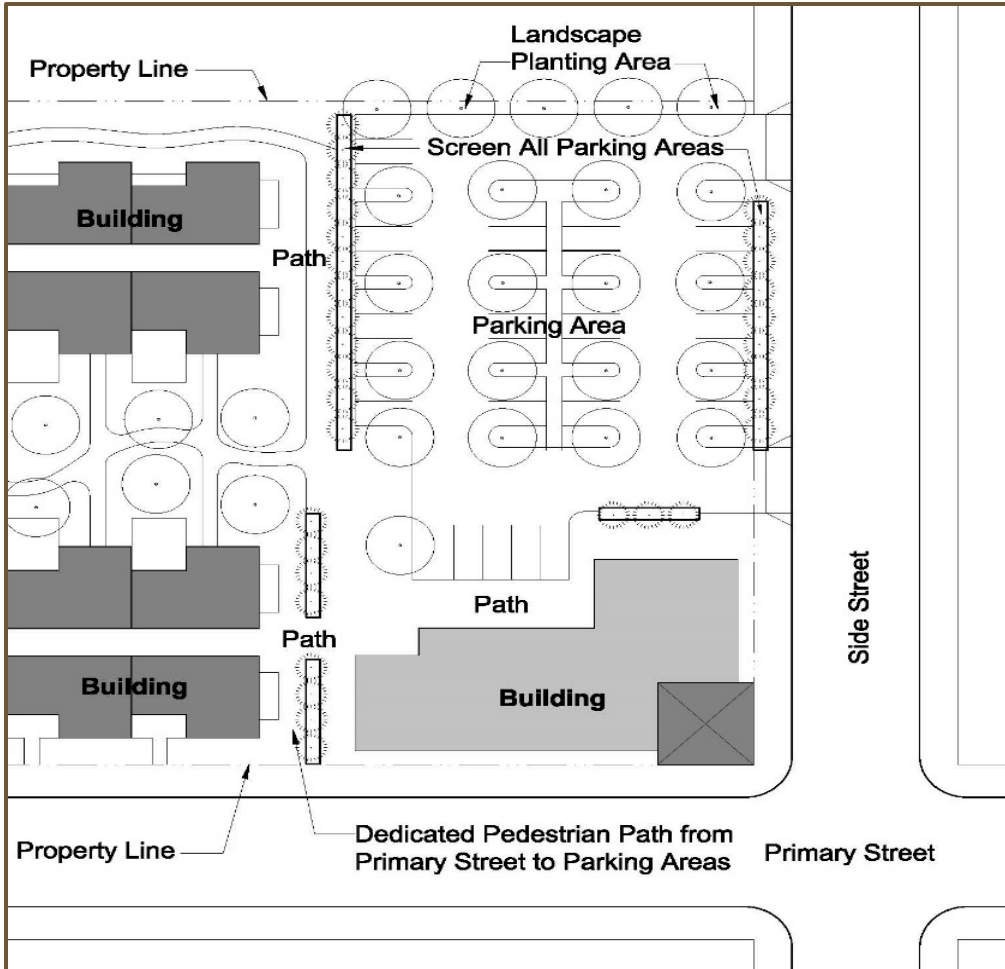

Figure 2.5-12 Conceptual Parking Design

2.5.1.6 Landscaped Buffers as Screening

Specific areas within the CENTRAL VILLAGE should incorporate buffers to protect village uses from adjacent industrial uses to the east and large thoroughfares, such as Airway Road and Cactus Road. Landscaped buffers help minimize potential collocation issues between residential and industrial land uses. The intent of this Specific Plan is to provide landscape buffers in lieu of walls whenever possible to soften the public realm and promote a pedestrian-oriented environment.

Figure 2.5-13, *Residential Development Adjacent to Airway Road*, and Figure 2.5-14, *Residential Development Adjacent to Cactus Road*, demonstrate design strategies that would characterize landscape buffers as screening along Airway Road and Cactus Road.



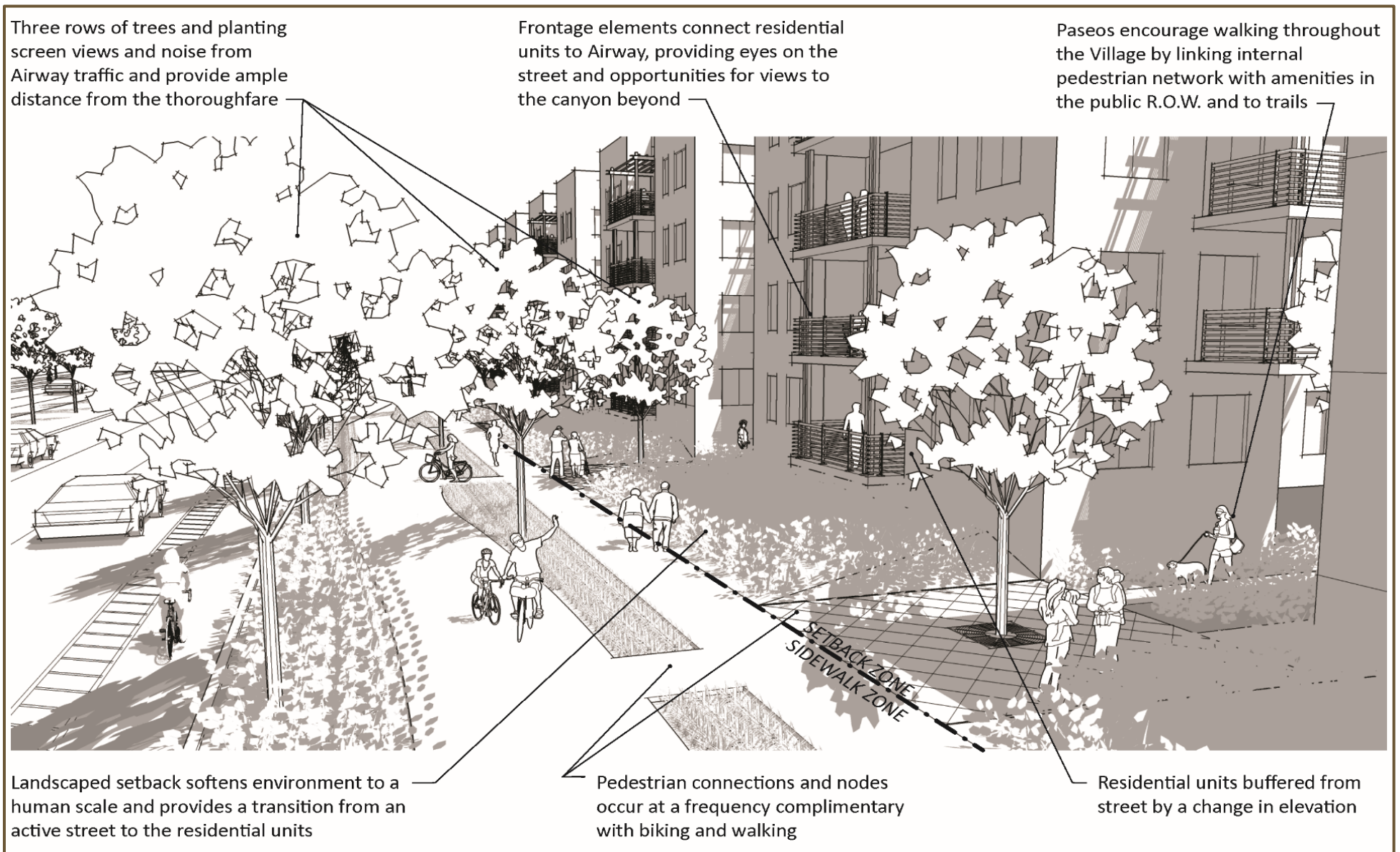

Figure 2.5-13 Residential Development Adjacent to Airway Road

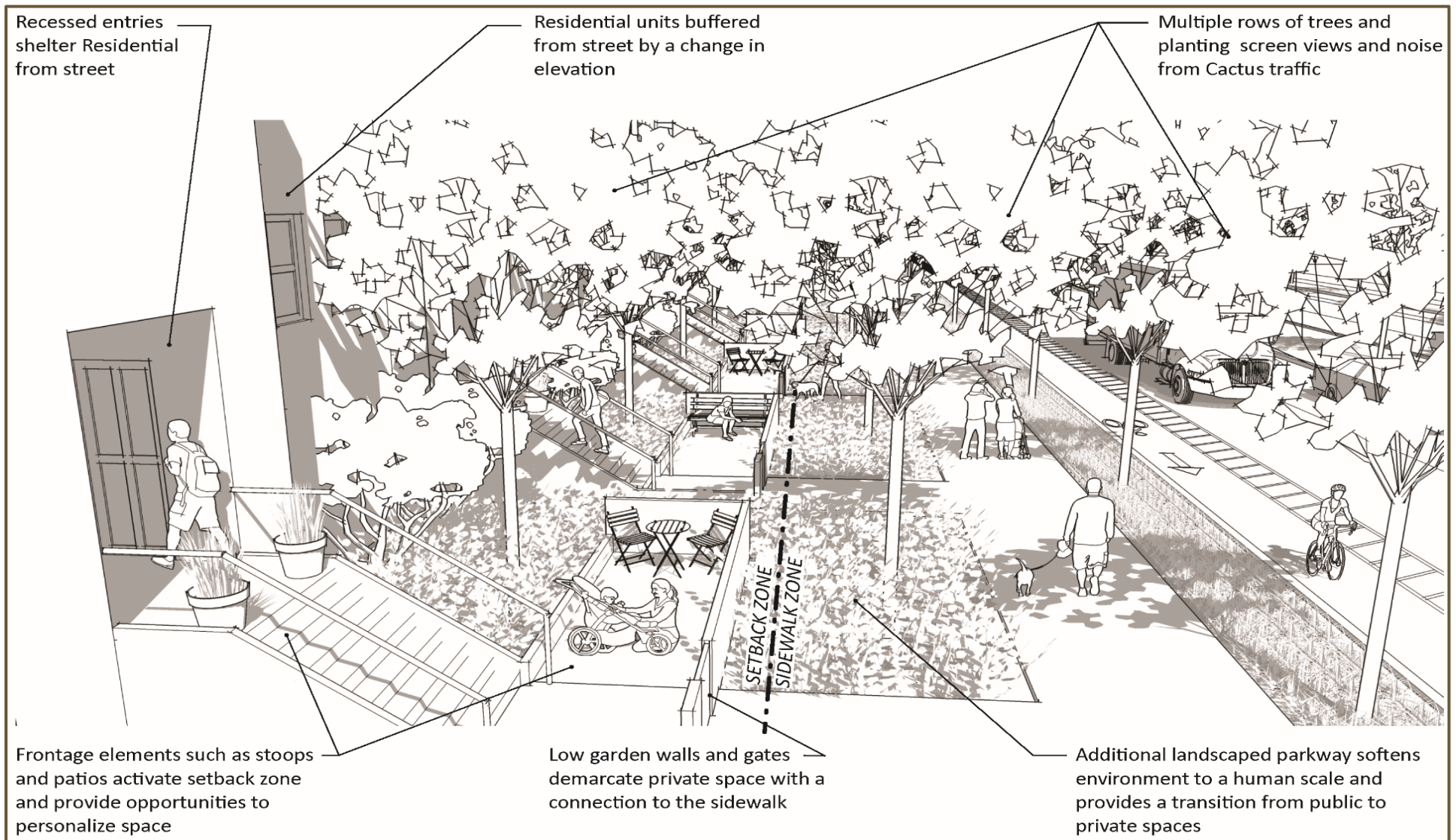

Figure 2.5-14 Residential Development Adjacent to Cactus Road





Landscape buffer used to screen residential uses from busy road.

Policy 2.5-43 Residential uses along Cactus Road and Airway Road should allow for a landscaped buffer to be integrated along the frontage of Cactus Road to separate residential uses from heavy truck traffic and industrial uses that are prevalent east of the CENTRAL VILLAGE.

Policy 2.5-44 Address the challenges presented by the collocation of industrial and residential uses by implementing the following design strategies:

- Provide clear demarcations between public and private areas, as well as residential and non-residential uses, with separate building entrances, building, and landscape design features, building separations, access control, or a change in levels and materials.
- Utilize a landscape setback between residential and industrial properties in lieu of high walls or fences
- Provide landscape screening and/or patio walls to reduce noise impacts and protect the privacy of residential units along high-traffic streets and intense uses.
- Address noise through the use of berms, planting, setbacks, and architectural design rather than with conventional wall barriers for noise generating uses.
- Use open spaces, such as pedestrian plazas, paseos, greenways, and courtyards, to serve dual functions as valuable community space and buffers between different uses.
- Minimize the number of residential units that have window and door openings that afford views into adjacent industrial uses located east of the CENTRAL VILLAGE. Whenever possible, orient the short end of buildings towards industrial uses.

2.5.1.7 Positive Frontage and Connecting Land Use Interfaces

CENTRAL VILLAGE is envisioned to have a seamless flow between buildings and land uses while providing appropriate transitions and demarcation of public to private space. The public realm is activated when this is achieved. These connections are established by the appropriate application of landscape and architectural design within the frontage zone.

Figure 2.5-16 through Figure 2.5-18 demonstrate design strategies that would characterize positive frontage and connecting land use interfaces in any location within the CENTRAL VILLAGE.

Policy 2.5-45 Locate community facilities and amenities next to proposed and existing open space to enhance their access and visibility and to allow

them to become focal points of the development, as conceptually shown on Figure 2.5-15, *Community Facilities Concept Design*.

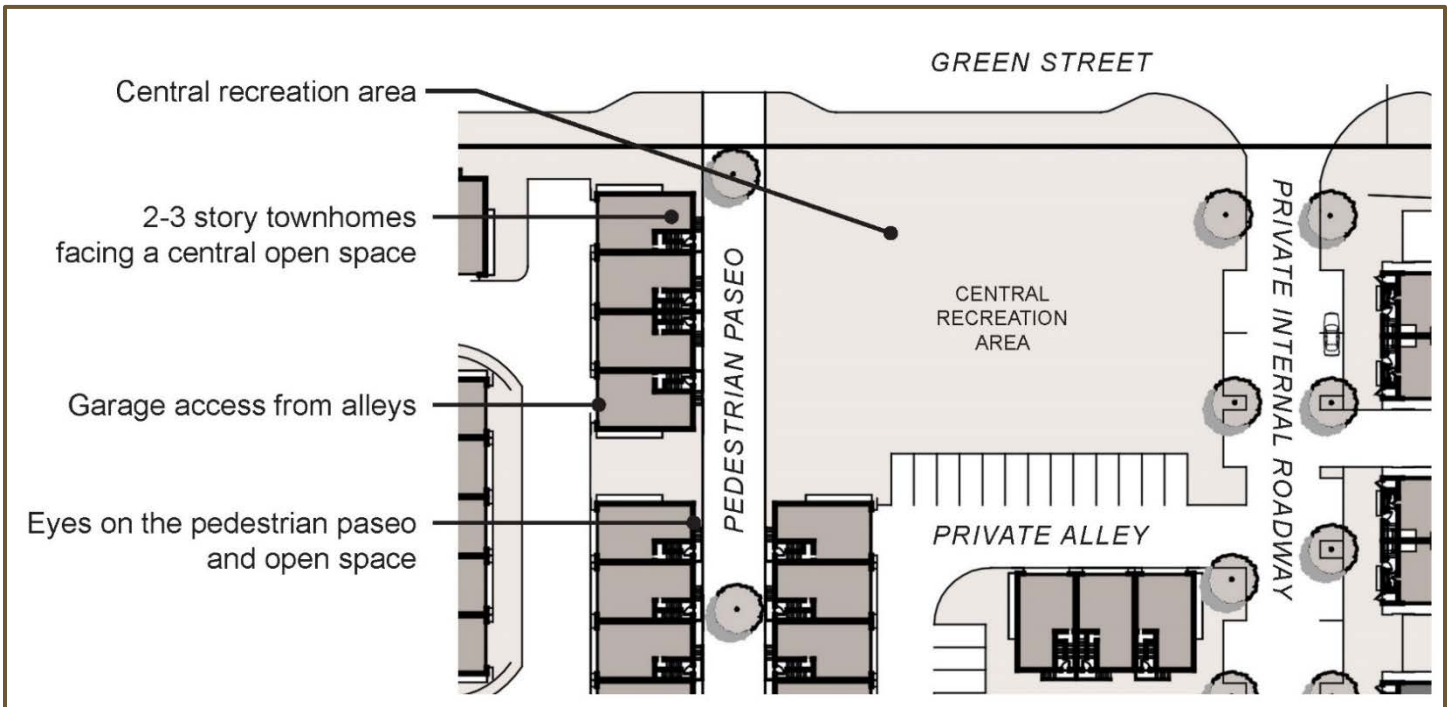

Figure 2.5-15 *Community Facilities Concept Design*

Policy 2.5-46 Design and arrange buildings around common areas and open space to define the open space. For example, buildings can be clustered around courtyards, greenways, paseos, and plazas.

Policy 2.5-47 Clearly define physical boundaries between private spaces and gathering spaces by utilizing elements such as low walls or plant materials.

Policy 2.5-48 Use of landscaping and insulating materials is encouraged to attenuate noise generated within and outside the community.

Policy 2.5-49 Use site planning to minimize noise in shared residential outdoor activity areas by locating the areas behind the buildings or in courtyards, or orienting the terraces to alleyways rather than streets whenever possible.

Policy 2.5-50 The design of parks should be integral to the design of adjacent building frontages. Commercial building frontages should include outdoor seating areas and plazas that front parks. Residential building frontages should include direct access to adjacent parks and provide balconies overlooking the parks for added visual security.



Buildings clustered around common open space.



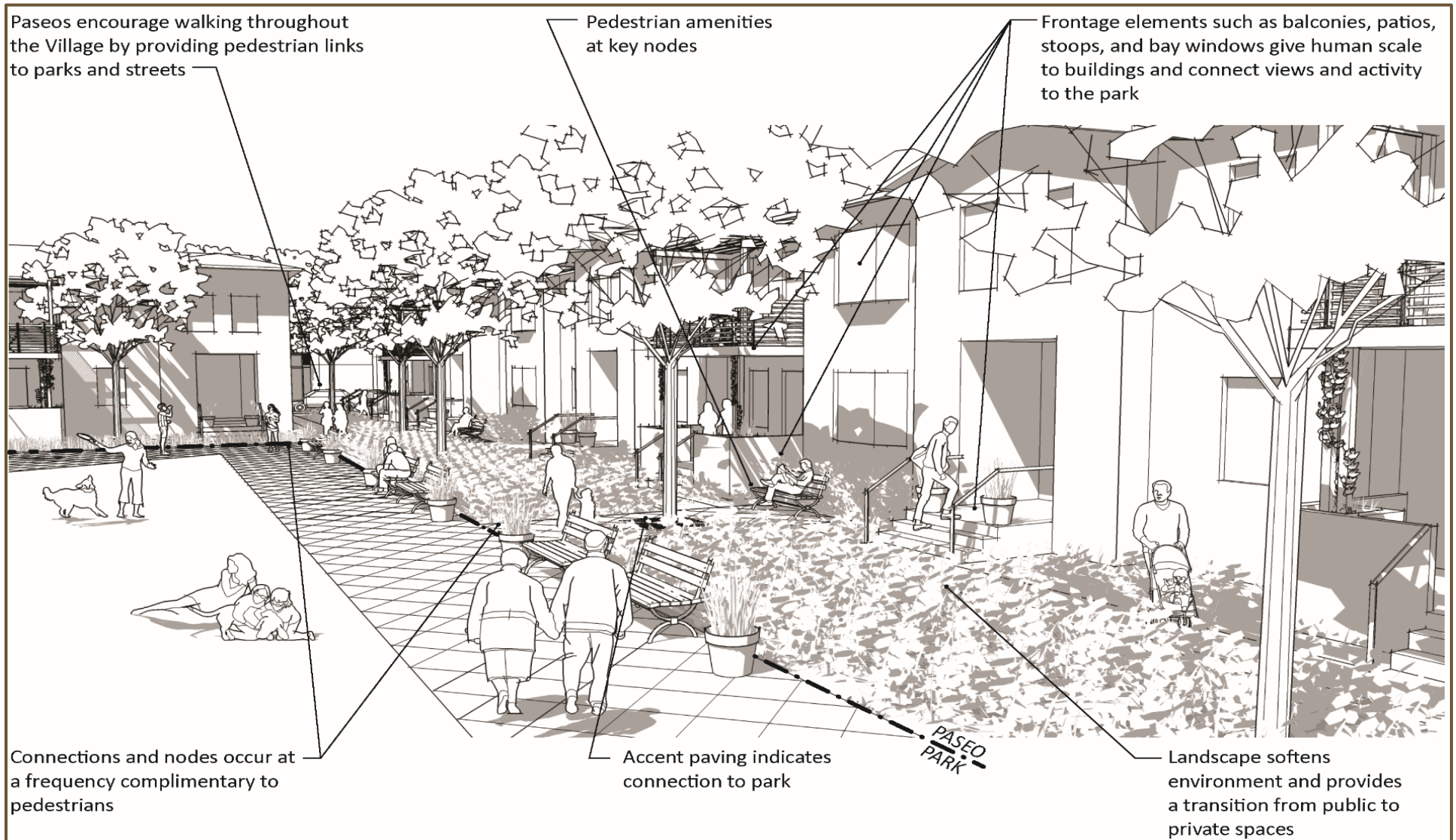

Figure 2.5-16 Residential Development Adjacent to Public Park

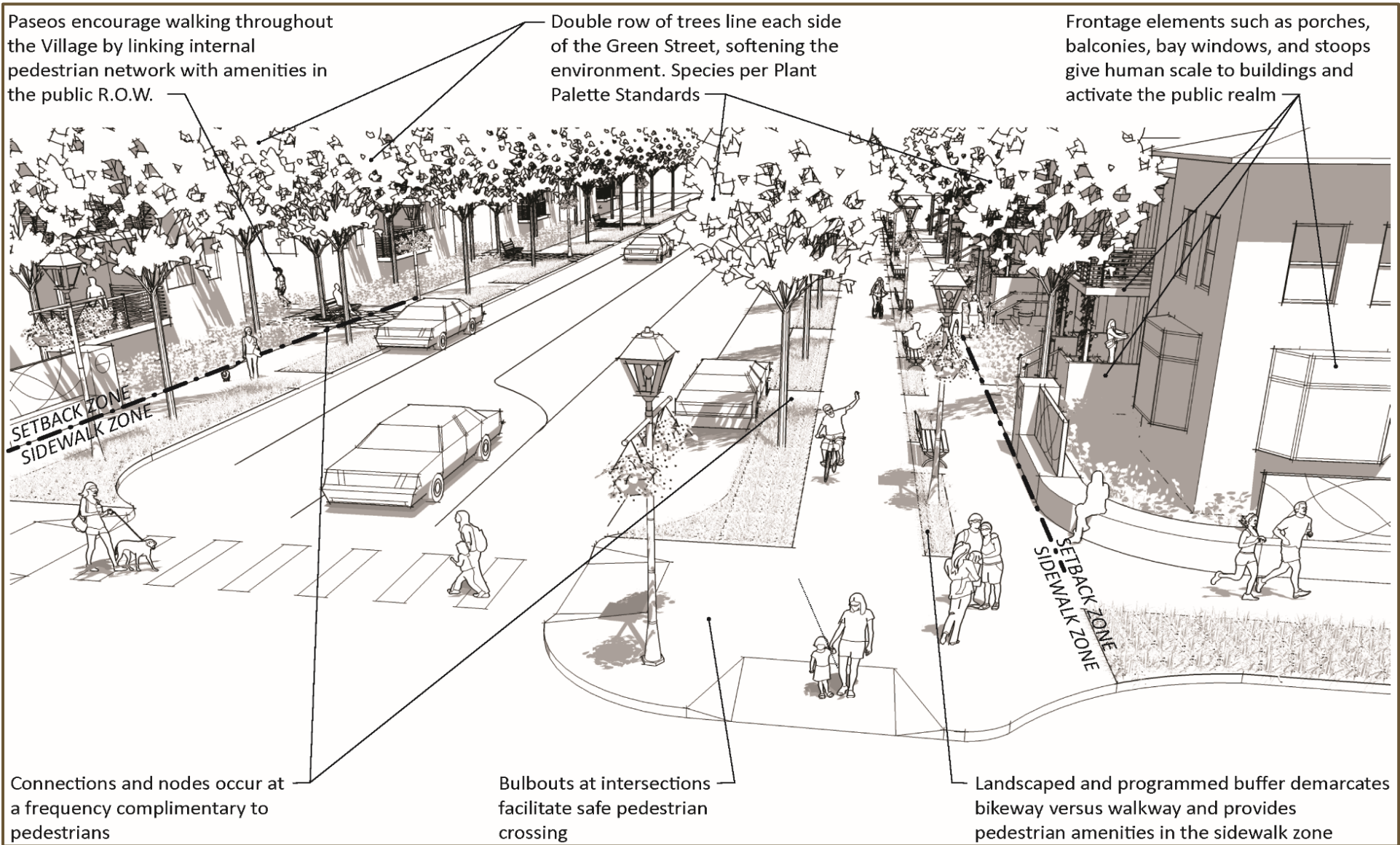

Figure 2.5-17 Residential Development Along Main Street



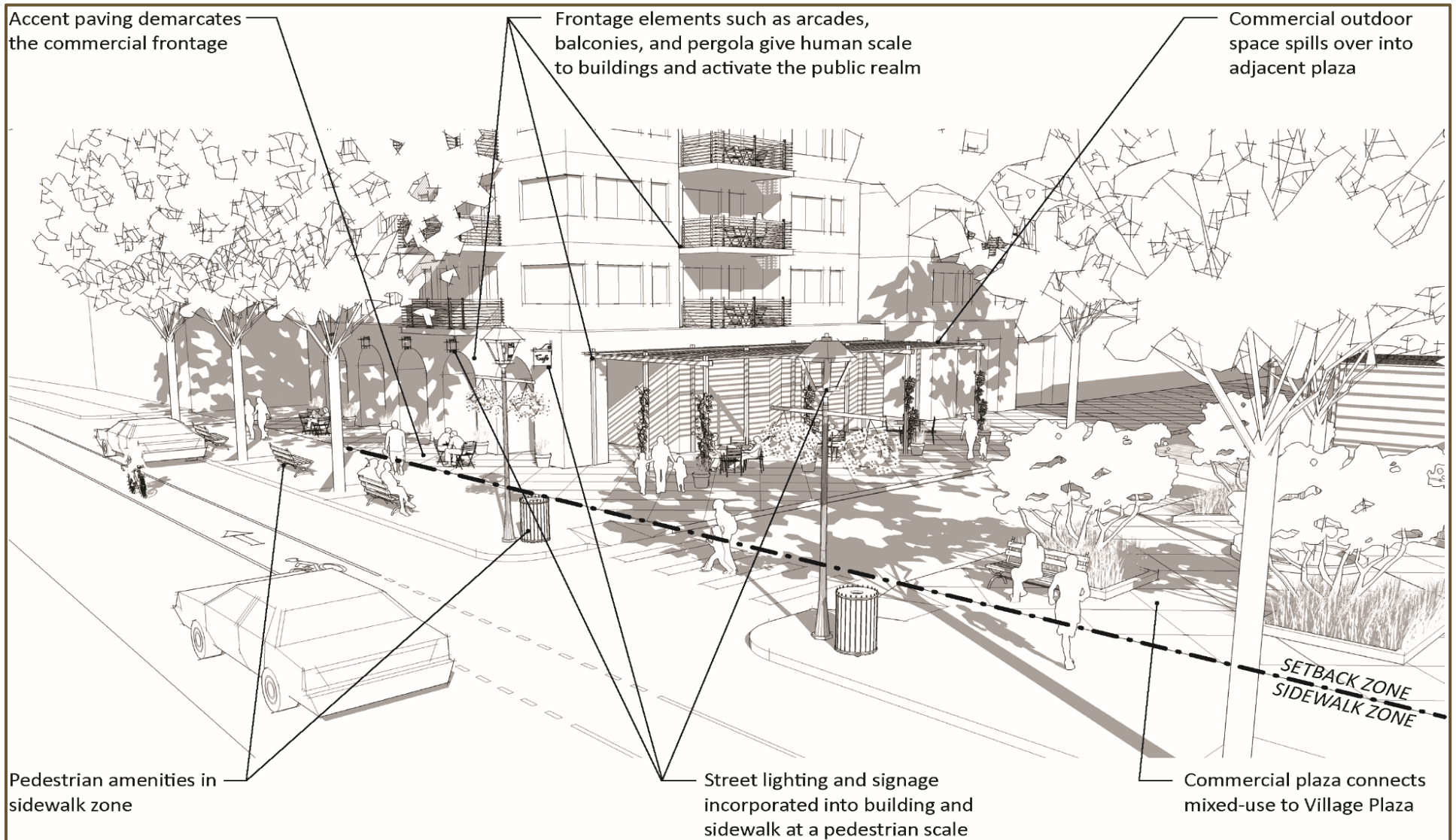

Figure 2.5-18 Frontage Elements on Mixed Use Development

Policy 2.5-51 Buildings that abut and frame parks should have special design consideration in order to create attractive facades, architectural features, articulation, and an inviting pedestrian experience.

2.5.2 ARCHITECTURAL DESIGN

Architectural design outlines requirements for building features and characteristics within CENTRAL VILLAGE. Architectural design includes the following components: building orientation; building form, massing, and articulation; building frontage types; building access; and building materials and colors. General architectural policies that apply to residential and mixed use planning areas within CENTRAL VILLAGE are provided below. These policies are intended to be flexible and may be expressed in an array of architectural solutions as long as they maintain the character of the village.

2.5.2.1 Building Orientation

Figure 2.5-19, *Typical Characteristics of Desired Building Orientation* depicts typical characteristics of desired building orientation within the CENTRAL VILLAGE.



Example of a residential building that incorporates various building frontage types.

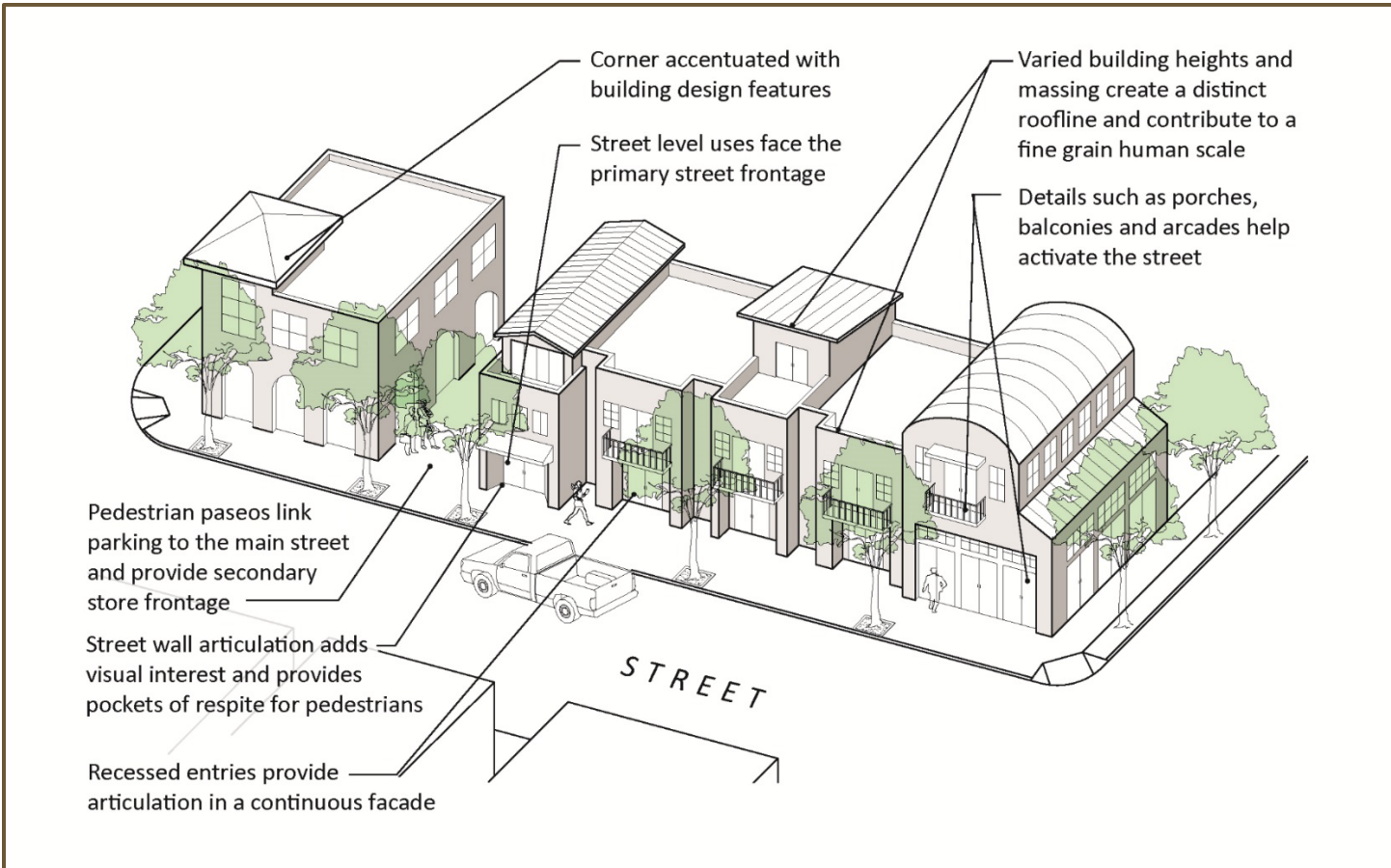

Figure 2.5-19 *Typical Characteristics of Desired Building Orientation*



Policy 2.5-52 Orient buildings to face the street, present an attractive and inviting façade, and take direct access from the street. Provide active spaces on the building front façade, as shown in Figure 2.5-19.

Policy 2.5-53 Place doors and windows in locations that face and are visible from main circulation roadways and internal streets to allow residents to have “eyes on the street” for natural surveillance.

Policy 2.5-54 Residential units located north of Airway Road should be designed to minimize building openings (windows and doors) and usable outdoor spaces (balconies, patios, etc.) from having a direct line-of-sight with SR-905.

Policy 2.5-55 Private open space (such as a yards, patios, or balconies) that is visible and accessible from inside the dwelling is strongly encouraged for all residential units.

Policy 2.5-56 Design buildings to maximize natural ventilation. Site and orient buildings to take advantage of natural daylight and prevailing breezes for increased cross ventilation, to reduce the need for mechanical air conditioning, and to enhance the functionality of ceiling fans.

Policy 2.5-57 Provide mechanical ventilation in all residential units proposed along roadways carrying high traffic volumes and in the areas where noise levels could exceed interior noise standards such that windows can remain closed at the choice of the occupants.

Policy 2.5-58 In commercial buildings, place loading and unloading areas so that commercial buildings shield nearby residential land uses from noise generated by loading dock and delivery activities. If necessary, additional sound barriers should be constructed on the commercial sites to reduce noise levels at nearby noise-sensitive uses.

Policy 2.5-59 Place commercial heating, ventilation, and air conditioning (HVAC) machinery within mechanical equipment rooms wherever possible.

Policy 2.5-60 Provide localized noise barriers or rooftop parapets around HVAC, cooling towers, and mechanical equipment so that line-of-sight to the noise source from the property line of the noise-sensitive receptors is blocked.

2.5.2.2 Building Form, Massing, and Articulation

Refer to Figure 2.5-20 through Figure 2.5-22, and Table 2.5-1 for concepts and strategies to achieve desired building form, massing, and articulation.



Design buildings to maximize natural ventilation.

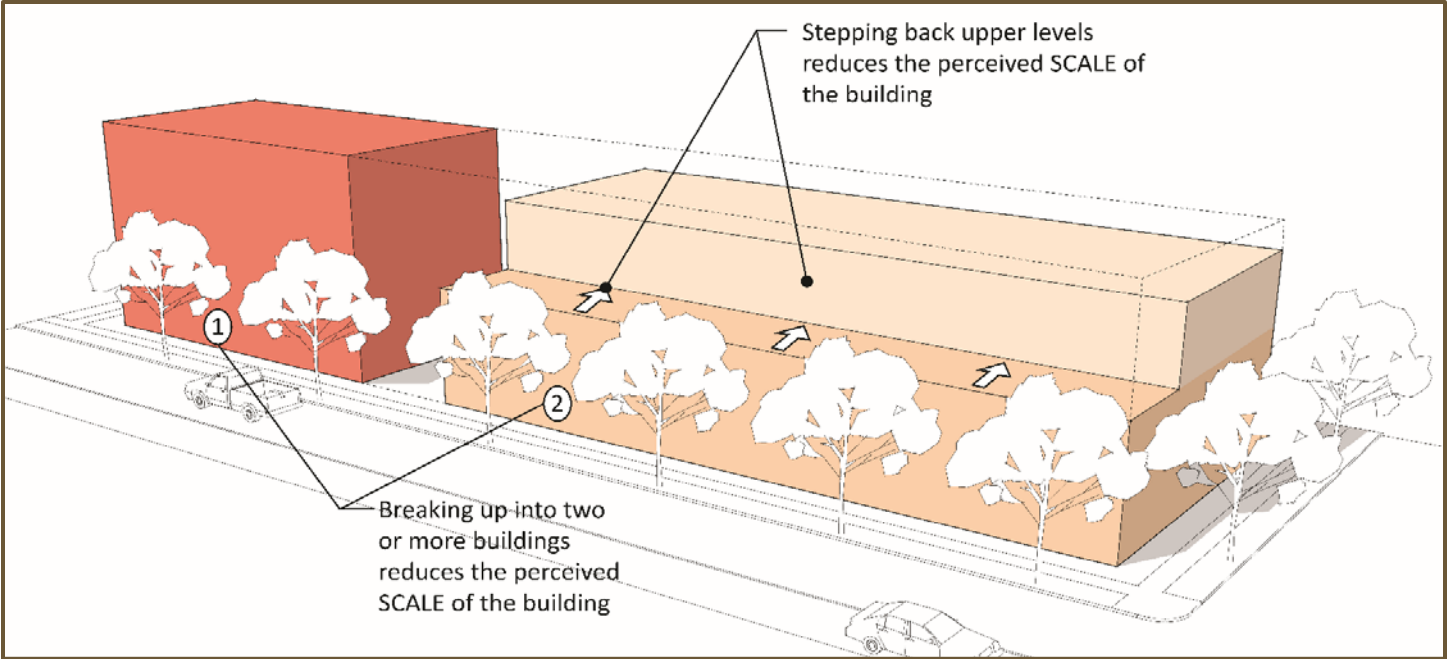

Figure 2.5-20 Building Scale

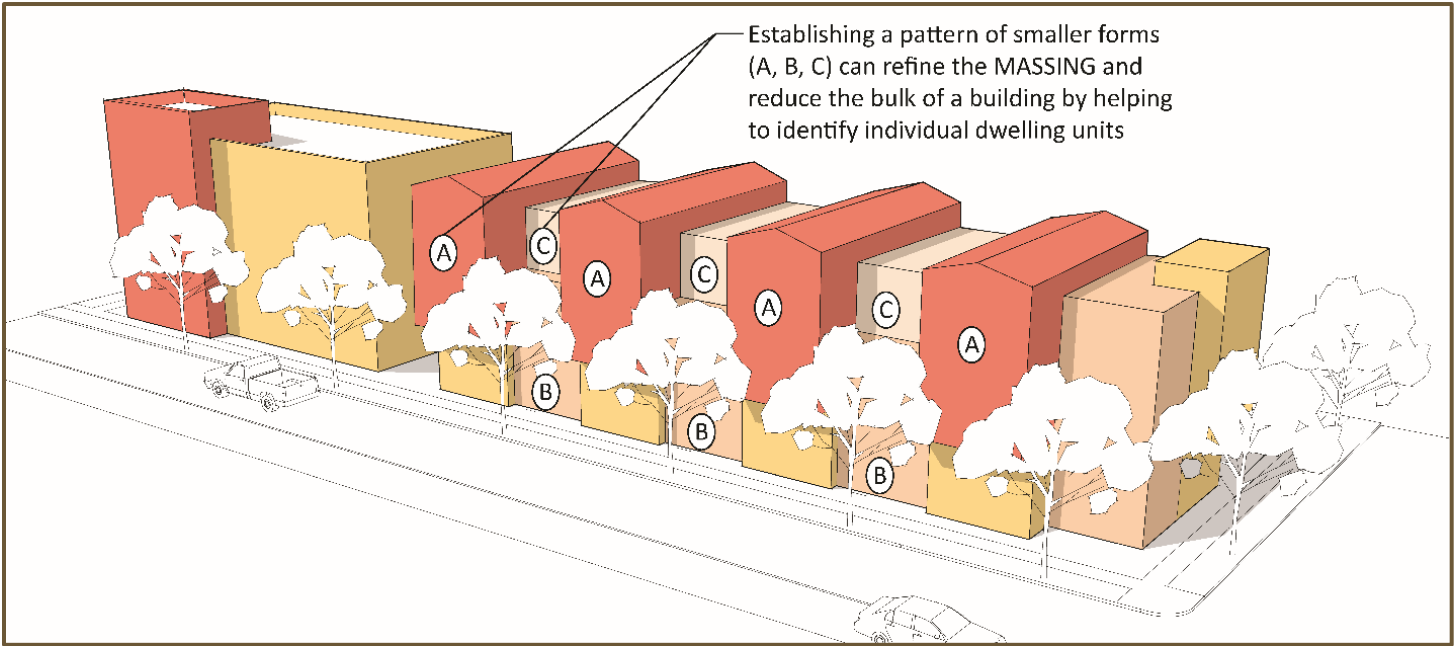

Figure 2.5-21 Building Massing



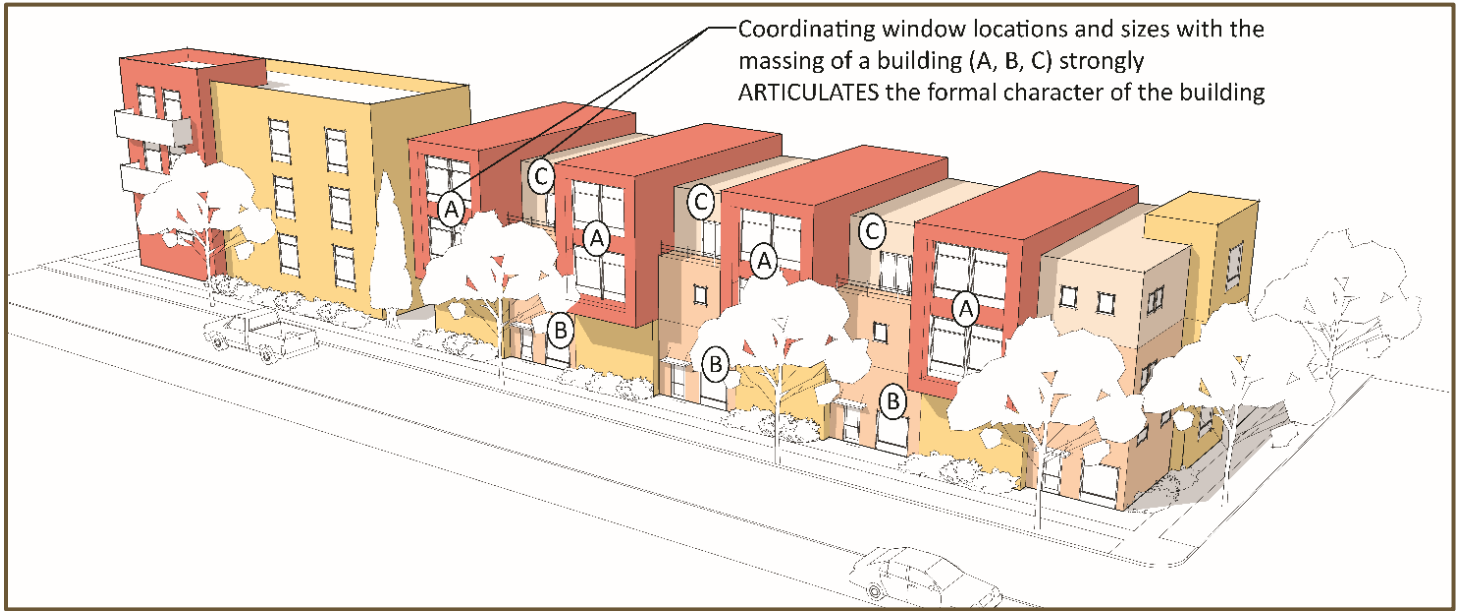

Figure 2.5-22 Building Articulation

Table 2.5-1 BUILDING FRONTAGE TYPES



A. Yard, Forecourt, Planter		
		<p>The building façade is at or near the setback line, and between the building façade and sidewalk are intentional landscaping, planters, garden walls, fences, and/or hedges.</p>
B. Bay Window		
		<p>A window built to project outward from the building façade.</p>
C. Balcony		
		<p>A platform elevated from the ground level, protruding from the building with adequate area for a person, furniture, and/or planters to occupy.</p>



TABLE 2.5-1 BUILDING FRONTAGE TYPES (CONT'D)



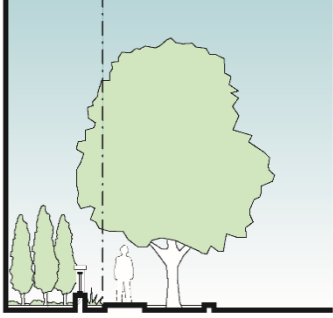
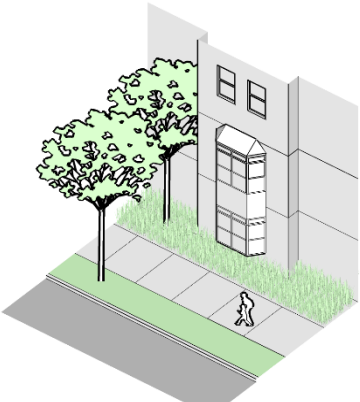
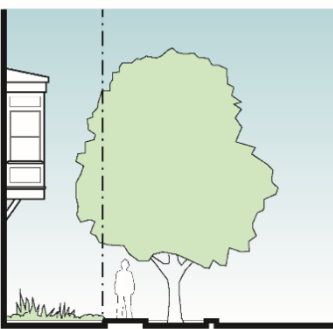

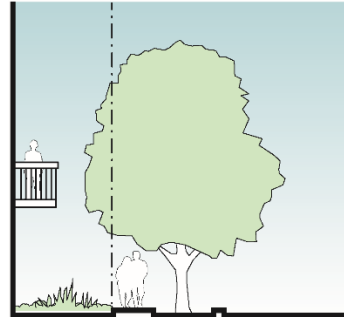
D. Porch, Patio		
		<p>A platform or exterior finished floor projecting in front of the entrance of a building that may be partially or fully covered to provide shelter, and is level with or near the ground floor elevation of the building.</p>
E. Stoop		
		<p>An element elevated from the street level and at or near the entry level to a building, with steps provided to access the entry from the street level.</p>
F. Arcade, Colonnade, Gallery		
		<p>A series of openings or façade details that approximate the scale of an entryway into the building and are open to the exterior on at least one side.</p>

TABLE 2.5-1 BUILDING FRONTAGE TYPES (CONT'D)

G. Awning, Canopy, Marquee, Sun Shade, Trellis

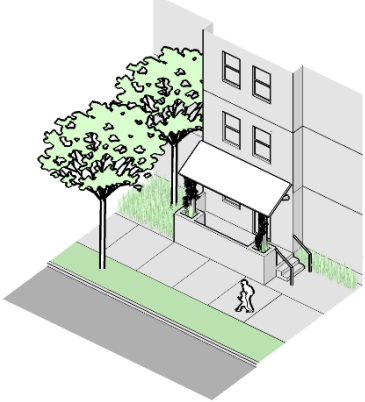
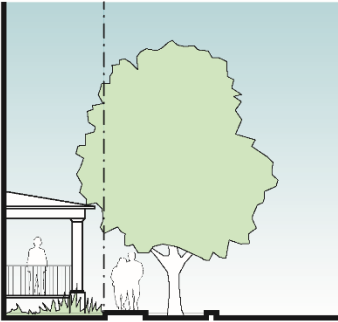
		<p>The building façade is at or near the setback line, and between the building façade and sidewalk are intentional landscaping, planters, garden walls, fences, and/or hedges.</p>
-----------------------------------------------------------------------------------	-----------------------------------------------------------------------------------	-------------------------------------------------------------------------------------------------------------------------------------------------------------------------------------

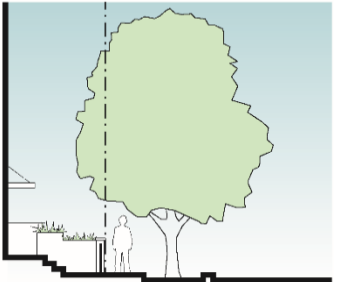
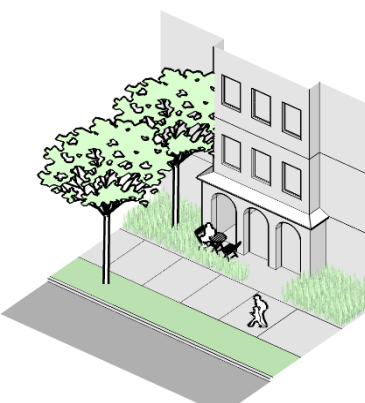
Policy 2.5-61 Avoid boxy and monotonous facades that lack human scale dimensions and have large expanses of flat wall planes. Provide a defined palette of design elements, such as decorative trim and other treatments to add visual interest to the façade.

Policy 2.5-62 Break up and vary roof lines within the overall horizontal plane. Combinations of roof heights that create variation and visual interest are encouraged.

Policy 2.5-63 Roofs of accessory structures, such as community buildings or carports, should be compatible with the overall architectural design of the remainder of the development.

Policy 2.5-64 Recessed windows and entrances are encouraged for increased shade and protection from the elements.

2.5.2.3 Building Frontage Types

The following Building Frontage Types shown in Table 2.5-1, *Building Frontage Types*, apply to all development in the CENTRAL VILLAGE.

Development proposed in the village should incorporate a minimum of two Frontage Types, outlined in Table 2.5-1, along the front and street side yard of each building.

Policy 2.5-65 Apply the selected frontage types across a building façade to achieve a consistent pattern and articulation per Section 2.5.2.2

2.5.2.4 Building Access

Policy 2.5-66 Orient, clearly mark, and illuminate entrances to commercial establishments so that the entrances are clearly visible from the fronting street, paseo, and/or entry plaza. Locate primary access from the

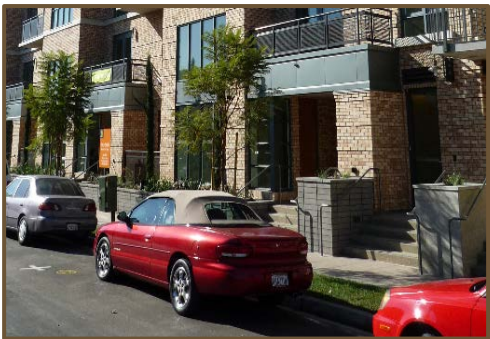

Unit entries visible from the street.



street, plaza, or paseo and locate secondary access from internal parking areas.

Policy 2.5-67 When provided, locate building lobbies in a prominent and visible area of the site, have direct access from the primary street frontage, and contribute to the image and identity of the development. Wherever possible, the mailboxes, bulletin boards, reception desk, and other common areas and amenities (where provided) should be located in or connected to the lobby.

Policy 2.5-68 Design attractive courtyard doors or gates at building entrances as an important architectural feature of the building or development.

Policy 2.5-69 Provide a dedicated walkway to the front door of each individual ground level townhome unit.

Policy 2.5-70 Emphasize and differentiate each dwelling unit’s entrance through architectural elements such as porches, stoops, or roof canopies, and detailing such as paint color, trim, materials, or awnings.

Policy 2.5-71 Provide clear visibility to the main entry of each dwelling unit from the nearest shared circulation walkway.

2.5.2.5 Building Materials and Colors

The following design standard and policies apply to all buildings within CENTRAL VILLAGE.

Design Standard 2.5-1 Use non-reflective finishes. Mirrored glass is prohibited.

Policy 2.5-72 Unify dwelling units, community facilities, and other structures within each planning area by a consistent use of building materials, textures, and colors.

Policy 2.5-73 Avoid frequent changes in building materials. It is recommended that no more than 3 base exterior finish materials should be used for any given building.

Policy 2.5-74 Use color as an important design element in the development’s appearance. The predominant colors for main buildings and accessory structures should be limited, should match, and should be generally consistent with an overall color theme for the development. Compatible accent colors are encouraged to enhance important building elements.

Policy 2.5-75 The color, decorative trim, and other architectural details is to be distinct yet compatible with the overall building color. Reserve bright



Attractive courtyard door at unit entry.



Compatible accent color enhances important building elements.



An overall color theme enhances the development’s appearance.

or intense colors for significant architectural massing, refined detailing such as grillwork, or more transient features such as awnings.

Policy 2.5-76 Leave materials such as brick, stone, copper, etc. in their natural colors. Avoid exposed edges and turn corners for veneer.

Policy 2.5-77 Use materials and colors that are compatible with the rest of the development for exterior columns or supports for building and landscape elements, such as trellises and porches.

Policy 2.5-78 Incorporate non-polluting and non-toxic materials and finishes with zero or low volatile organic compounds (VOCs).

2.5.3 LANDSCAPE DESIGN

The CENTRAL VILLAGE landscape theme conveys a strong community identity by displaying consistent, visually appealing, and culturally sensitive designs that respond to the local climate and promote non-vehicular connectivity.

This section includes design standards and policies, where applicable, for the following landscape design components: the village-wide plant palette, streetscape design, entries and monuments, walls and fencing, brush management, slope plantings, lighting, irrigation and water conservation, and maintenance.

The landscape design standards and policies provided in this section provide fundamental design objectives that establish the thematic character of CENTRAL VILLAGE through the use of consistent and complimentary landscape and hardscape design. These landscape design standards and policies are intended to be flexible and may be expressed in an array of design solutions as long as they maintain the intended character of the village.

2.5.3.1 Plant Palette

The plant palette for the CENTRAL VILLAGE is composed of native species found within a coastal desert climate zone, drought tolerant species, and non-native species common to this region. This water-wise palette is appropriate for climate, and is able to withstand times of severe drought.

Plant palettes consisting of canopy and accent trees (chosen from the Otay Mesa Community Plan Update), low shrubs, and ground covers shall be used to enhance the visual quality of the CENTRAL VILLAGE, maximize visibility, and provide safe and enjoyable pedestrian experiences.

All of the tree species have been selected from the Otay Mesa Community Plan Update. The majority of tree species are selected for providing ample shade among pedestrian walkways, streetscapes, and gathering spaces.



Sun shades help reduce glare and heat from afternoon sun.



Other tree species were chosen for flowering and other accenting attributes that provide a strong visual character.

Shrubs and groundcover are composed in a large variety of masses. This planting technique increases the visual character of flowering- and foliage-only species. The larger massing also increases the bearing capacity for long-term survival and a stronger tolerance to highly used areas.

Groundcovers, low-growing shrubs or ornamental grasses, and mulches shall be used predominately throughout the CENTRAL VILLAGE. Turf shall be limited to areas designated for active recreation and informal play areas.

The plant matrix included herein represents a general palette of appropriate plant material, although a more defined palette will be required for specific development areas throughout the village.

The following design standards and policy apply to all landscaped areas within CENTRAL VILLAGE.

Design Standard 2.5-2 Per the requirements of the Otay Mesa Community Plan, tree species used within CENTRAL VILLAGE shall be selected from the City of San Diego's Otay Mesa Street Tree Plan. Table 2.5-2, *Village-Wide Plant Palette*, provides a detailed plant palette for the CENTRAL VILLAGE and Figure 2.5-23 and Figure 2.5-24 provide representative images of the plant palette.

Design Standard 2.5-3 Prohibited and invasive plant species shall not be knowingly used within CENTRAL VILLAGE. Prohibited plants are those which do not satisfy the minimum performance standards for the site area per the City's Land Development Code Chapter 14, Article 2, Division 4, *Landscape Regulations*.

Design Standard 2.5-4 Groundcovers, low-growing shrubs or ornamental grasses, and mulches shall be used predominately throughout the CENTRAL VILLAGE. Turf shall be limited to areas designated for active recreation and informal play areas.

Policy 2.5-79 All trees should be maintained in a healthy state and replaced in-kind if removal is necessary.

2.5.3.2 Streetscape Design

The streetscapes within CENTRAL VILLAGE focus on size, scale, landscaping, and traffic calming features to encourage pedestrian activity and safe travel for motorists, transit riders, pedestrians, and cyclists. High density residential uses in combination with commercial uses, particularly in the heart of the CENTRAL VILLAGE, provide the activity needed to bring the streets

Table 2.5-2 VILLAGE-WIDE PLANT PALETTE

BOTANICAL NAME	COMMON NAME	CHARACTERISTICS							
		TYPE	HEIGHT	WIDTH	CROWN	SIZE	SPACING	DT	NATIVE
Airway Road Street Trees									
<i>Albizia julibrissin</i>	Silk Tree	D	20'-40'	--	20'-40'	24" - 36" box	30'-35'	Yes *	No
<i>Jacaranda mimosifolia</i>	Jacaranda	D	20'-40'	--	20'-40'	24" - 36" box	30'-35'	Yes *	No
<i>Koelreuteria bipinnata</i>	Chinese Flame Tree	D	20'-40'	--	20'-40'	24" - 36" box	30'-35'	Yes *	No
<i>Syagrus romanzoffiana</i>	Queen Palm	P	40' +	--	10'-20'	12' BTH min.	25'-30'	Yes *	No
Cactus Road Street Trees									
<i>Albizia julibrissin</i>	Silk Tree	D	20'-40'	--	20'-40'	24" - 36" box	30'-35'	Yes *	No
<i>Geijera parviflora</i>	Australian Willow	E	20'-40'	--	20'-35'	24" - 36" box	20'-30'	Yes	No
Village Entry/Residential Street Trees									
<i>Callistemon citrinus</i>	Lemon Bottlebrush	D	15'-25'	--	15'-20'	24" - 36" box	25'-30'	Yes	No
<i>Calodendrum capense</i>	Cape Chestnut	D	20'-40'	--	40'+	24" - 36" box	35'-40'	Yes *	No
<i>Chilopsis linearis</i>	Desert Willow	D	20'-40'	--	20'-40'	24" - 36" box	30'-35'	Yes	Yes
<i>Chitalpa tashkentensis</i>	Chitalpa	D	20'-40'	--	20'-40'	24" - 36" box	25'-30'	Yes	No
<i>Geijera parviflora</i>	Australian Willow	E	20'-40'	--	20'-35'	24" - 36" box	20'-30'	Yes	No
<i>Koelreuteria bipinnata</i>	Chinese Flame Tree	D	20'-40'	--	20'-40'	24" - 36" box	30'-35'	Yes *	No
<i>Lagerstroemia x 'Muskogee'</i>	Muskogee Crape Myrtle	D	20'	--	20'	24" - 36" box	25'-30'	Yes *	No
<i>Olea europaea 'Swan Hill'</i>	Swan Hill Olive (non-fruiting)	E	25'-30'	--	20'-30'	24" - 36" box	30'-35'	Yes *	No
<i>Pistacia chinensis</i>	Chinese Pistache	D	40'+	--	40'+	24" - 36" box	35'-40'	Yes *	No
<i>Tabebuia impetiginosa</i>	Pink Trumpet Tree	D	25'-35'	--	25'-35'	24" - 36" box	30'-35'	Yes *	No
Green Street Trees									
<i>Jacaranda mimosifolia</i>	Jacaranda	D	40'+	--	40'+	24" - 36" box	30'-35'	Yes *	No
<i>Koelreuteria bipinnata</i>	Chinese Flame Tree	D	20'-40'	--	20'-40'	24" - 36" box	30'-35'	Yes *	No
<i>Olea europaea 'Swan Hill'</i>	Swan Hill Olive (non-fruiting)	E	25'-30'	--	20'-30'	24" - 36" box	30'-35'	Yes *	No
<i>Pistacia chinensis</i>	Chinese Pistache	D	40'+	--	40'+	24" - 36" box	35'-40'	Yes *	No
<i>Platanus acerifolia 'Bloodgood'</i>	London Plane	D	40'+	--	40'+	24" - 36" box	30'-35'	Yes *	No
<i>Tabebuia impetiginosa</i>	Pink Trumpet Tree	D	25'-35'	--	25'-35'	24" - 36" box	30'-35'	Yes *	No
<i>Tipuana tipu</i>	Tipu Tree	E	30'-40'+	--	30'-40'+	24" - 36" box	30'-35'	Yes *	No
<i>Ulmus parvifolia</i>	Chinese Elm	D	40'+	--	40'+	24" - 36" box	30'-35'	Yes *	No
Large Shrubs									
<i>Acca sellowiana</i>	Pineapple Guava	--	8'-12'	8'-12'	--	--	--	Yes *	--
<i>Arbutus unedo 'Compacta'</i>	Compact Strawberry Tree	--	6'-8'	5'-6'	--	--	--	Yes	--
<i>Arctostaphylos densiflora 'Howard McMinn'</i>	Howard McMinn Manzanita	--	6'-8'	6'-8'	--	--	--	Yes	--
<i>Baccharis pilularis ssp. consanguinea</i>	Coyote Brush	--	4'-8'	6'-8'	--	--	--	Yes	--
<i>Ceanothus species + cultivars</i>	Wild Lilac (name varies)	--	Varies	Varies	--	--	--	Yes	--



Table 2.5-2 VILLAGE-WIDE PLANT PALETTE

BOTANICAL NAME	COMMON NAME	CHARACTERISTICS							
		TYPE	HEIGHT	WIDTH	CROWN	SIZE	SPACING	DT	NATIVE
Cotinus coggygia 'Royal Purple'	Purple Smoke Tree	--	12'-16'	10'-15'	--	--	--	Yes	--
Dodonaea viscosa 'Purpurea'	Purple Hopseed Bush	--	12'-18'	6'-12'	--	--	--	Yes *	--
Elaeagnus pungens 'Fruitlandii'	Fruitland Silverberry	--	6'-10'	6'-10'	--	--	--	Yes	--
Fremontodendron species + cultivars	Flannel Bush	--	Varies	Varies	--	--	--	Yes	--
Grevillea species + cultivars	Varies	--	Varies	Varies	--	--	--	Yes *	--
Heteromeles arbutifolia	Toyon	--	12'-18'	20+	--	--	--	Yes	--
Leptospermum scoparium cultivars	New Zealand Tea Tree	--	4'-12'	4'-10'	--	--	--	Yes	--
Melaleuca nesophila	Pink Melaleuca	--	10'-18'	15'-20'	--	--	--	Yes	--
Myrsine africana	African Boxwood	--	3'-8'	4'-5'	--	--	--	Yes	--
Myrtus communis	Myrtle	--	8'-10'	8'-10'	--	--	--	Yes *	--
Prunus ilicifolia ssp. ilicifolia	Hollyleaf Cherry	--	10'-18'	8'-10'	--	--	--	Yes	--
Rhamnus californica	California Coffee Berry	--	8'-15'	8'-10'	--	--	--	Yes	--
Rhus integrifolia	Lemonade Berry	--	20+	20+	--	--	--	Yes	--
Rhus laurina	Laurel Sumac	--	12'-20'	12'-20'	--	--	--	Yes	--
Tecoma stans + cultivars	Yellow Bells	--	Varies	Varies	--	--	--	Yes *	--
Accent Shrubs									
Aeonium species + cultivars	Canary Island Rose (name varies)	--	Varies	Varies	--	--	--	Yes	--
Agave species	Agave	--	Varies	Varies	--	--	--	Yes	--
Aloe species	Aloe	--	Varies	Varies	--	--	--	Yes	--
Anigozanthos species + cultivars	Kangaroo Paw	--	1'-5'	1'-5'	--	--	--	Yes*	--
Arctostaphylos species	Manzanita	--	Varies	Varies	--	--	--	Yes	--
Bougainvillea species + cultivars	Bougainvillea	--	Varies	Varies	--	--	--	Yes	--
Bulbine frutescens + cultivars	Stalked Bulbine	--	1'-2'	Varies	--	--	--	Yes	--
Calliandra eriophylla	Pink Fairy Duster	--	1'-3'	3'-4'	--	--	--	Yes	--
Calliandra californica	Baja Fairy Duster	--	2'-6'	4'-5'	--	--	--	Yes	--
Callistemon 'Little John'	Dwarf Bottlebrush	--	3'-5'	4'-6'	--	--	--	Yes	--
Ceanothus species + cultivars	Wild Lilac (name varies)	--	Varies	Varies	--	--	--	Yes	--
Cistanthe grandiflora	Rock Purslane	--	1'	2'-3'	--	--	--	Yes	--
Cordyline species + cultivars	Grass Palm (name varies)	--	Varies	Varies	--	--	--	Varies	--
Cotinus coggygia species + cultivars	Smoketree	--	Varies	Varies	--	--	--	Yes*	--
Crassula species + cultivars	Varies	--	Varies	Varies	--	--	--	Yes	--
Dasyilirion quadrangulatum	Mexican Grass Tree	--	4'-7'	4'-7'	--	--	--	Yes	--
Dianella species + cultivars	Flax Lily (name varies)	--	Varies	Varies	--	--	--	Varies	--
Diets species + cultivars	Fortnight Lily	--	Varies	Varies	--	--	--	Yes*	--

Table 2.5-2 VILLAGE-WIDE PLANT PALETTE

BOTANICAL NAME	COMMON NAME	CHARACTERISTICS							
		TYPE	HEIGHT	WIDTH	CROWN	SIZE	SPACING	DT	NATIVE
Echeveria species + cultivars	Hen and Chicks (name varies)	--	Varies	Varies	--	--	--	Yes	--
Echinocactus grusonii	Golden Barrel Cactus	--	2'	2'	--	--	--	Yes	--
Furcraea foetida 'Mediopicta'	Variegated Mauritius hemp	--	4'-5'	6'-8'	--	--	--	Yes	--
Grevillea species + cultivars	Varies	--	Varies	Varies	--	--	--	Yes	--
Hesperaloe parviflora	Red Yucca	--	3'-4'	5'-7'	--	--	--	Yes	--
Kalanchoe species + cultivars	Varies	--	Varies	Varies	--	--	--	Yes	--
Lantana x 'New Gold'	New Gold Lantana	--	1'-2'	2'-3'	--	--	--	Yes	--
Lavandula species	Lavender	--	2'-4'	2'-4'	--	--	--	Varies	--
Leonotis leonurus	Lion's Tail	--	4'-8'	4'-6'	--	--	--	Yes	--
Leucophyllum frutescens + cultivars	Texas Sage	--	6'-8'	6'-8'	--	--	--	Yes	--
Myrtus communis cultivars	Dwarf Myrtle (name varies)	--	2'-3'	2'-3'	--	--	--	Yes	--
Olea europaea 'Montra'	Little Ollie Dwarf Olive	--	4'-6'	4'-6'	--	--	--	Yes	--
Punica granatum cultivars	Dwarf Pomegranate	--	2'-3'	4'-5'	--	--	--	Yes	--
Raphiolepis indica cultivars	India Hawthorn	--	2'-5'	2'-6'	--	--	--	Yes	--
Rosa species + cultivars	Rosa	--	Varies	Varies	--	--	--	Varies	--
Rosmarinus officinalis cultivars	Rosemary (name varies)	--	Varies	Varies	--	--	--	Yes	--
Salvia species + cultivars	Sage (name varies)	--	Varies	Varies	--	--	--	Yes*	--
Westringia species + cultivars	Coast Rosemary	--	4'-6'	5'-8'	--	--	--	Yes*	--
Yucca species	Yucca	--	Varies	Varies	--	--	--	Yes	--
Ornamental Grasses and Grass-Like Plants									
Bouteloua gracilis 'Blonde Ambition'	Blonde Ambition Blue Grama Grass	--	1'-3'	1'-3'	--	--	--	Yes	--
Carex divulsa	Eurasian Grey Sedge	--	1'-2'	1'-2'	--	--	--	No	--
Chondropetalum elephantinum	Large Cape Rush	--	3'-5'	4'-6'	--	--	--	Yes	--
Chondropetalum tectorum	Small Cape Rush	--	2'-3'	3'-4'	--	--	--	Yes	--
Festuca mairei 'Greenlee's Form'	Atlas Fescue	--	2'-3'	2'-3'	--	--	--	Yes	--
Festuca muelleri	Mueller's Fescue	--	< 1'	< 1'	--	--	--	Yes	--
Helictotrichon sempervirens	Blue Oat Grass	--	1'-3'	1'-3'	--	--	--	Yes	--
Juncus patens 'Elk Blue'	Elk Blue California Gray Rush	--	1'-2'	1'-2'	--	--	--	Yes	--
Leymus condensatus 'Canyon Prince'	Canyon Prince Wild Rye	--	2'-3'	5'-6'	--	--	--	Yes	--
Leymus arenarius 'Glaucus'	Blue Rye	--	1'-3'	5'-6'	--	--	--	Yes	--
Lomandra longifolia 'LM300'	Breeze Dwarf Mat Rush	--	2'-3'	2'-4'	--	--	--	Yes	--
Lomandra longifolia 'LM400'	Nyalla Mat Rush	--	3-4'	3-4'	--	--	--	Yes	--
Muhlenbergia capillaris 'Regal Mist'	Regal Mist Pink Muhly	--	2'-3'	2'-3'	--	--	--	Yes	--
Muhlenbergia lindheimeri 'Autumn Glow'	Autumn Glow Muhly	--	3'-5'	3'-4'	--	--	--	Yes	--



BOTANICAL NAME	COMMON NAME	CHARACTERISTICS								
		TYPE	HEIGHT	WIDTH	CROWN	SIZE	SPACING	DT	NATIVE	
Muhlenbergia rigens	Deer Grass	--	2'-3'	2'-3'	--	--	--	Yes	--	
Vines and Ground Covers										
Baccharis pilularis 'Pigeon Point'	Dwarf Coyote Brush	--	--	--	--	--	--	Yes	--	
Bougainvillea species + cultivars	Bougainvillea	--	--	--	--	--	--	Yes *	--	
Ceanothus species + cultivars	Wild Lilac (name varies)	--	--	--	--	--	--	Yes	--	
Clytostoma callistegioides	Lavander Trumpet Vine	--	--	--	--	--	--	No	--	
Distictis buccinatoria	Blood Red Trumpet Vine	--	--	--	--	--	--	No	--	
Jasminum polyanthum	Pink Jasmine	--	--	--	--	--	--	No	--	
Gazania spp.	Gazania	--	--	--	--	--	--	Yes *	--	
Hardenbergia spp.	Lilac Vine (name varies)	--	--	--	--	--	--	No	--	
Dymondia margaretae	Silver Carpet	--	--	--	--	--	--	Yes	--	
Juniperus species + cultivars	Juniper	--	--	--	--	--	--	Yes *	--	
Lampranthus spp.	Purple Ice Plant	--	--	--	--	--	--	Yes	--	
Macfadyena unguis-cati	Cat's Claw Vine	--	--	--	--	--	--	Yes *	--	
Myoporum parvifolium	Prostrate Myoporum	--	--	--	--	--	--	Yes	--	
Pandorea jasminoides + cultivars	Bower Vine	--	--	--	--	--	--	No	--	
Pelargonium peltatum	Ivy Geranium	--	--	--	--	--	--	Yes *	--	
Pyrostegia venusta	Flame Vine	--	--	--	--	--	--	No	--	
Rosa banksiae	Lady Banks Rose	--	--	--	--	--	--	Yes *	--	
Rosa floribunda 'Cecile Brunner Climbing'	Sweetheart Rose	--	--	--	--	--	--	No	--	
Rosmarinus officinalis 'Huntington Carpet'	Huntington Carpet Rosemary	--	--	--	--	--	--	Yes *	--	
Sedum spp.	Stonecrop	--	--	--	--	--	--	Yes	--	
Senecio serpens	Dwarf Blue Chalksticks	--	--	--	--	--	--	Yes	--	
Senecio talinoides ssp. mandraliscae	Blue Chalksticks	--	--	--	--	--	--	Yes	--	
Wisteria floribunda + cultivars	Japanese Wisteria	--	--	--	--	--	--	No	--	
Wisteria sinensis + cultivars	Chinese Wisteria	--	--	--	--	--	--	No	--	
Wildflowers										
Achillea millefolium	Common Yarrow	--	--	--	--	--	--	Yes	--	
Clarika amoena	Farewell Spring	--	--	--	--	--	--	Yes	--	
Collinsia heterophylla	Chinese Houses	--	--	--	--	--	--	Yes	--	
Eschscholzia californiaca	California Poppy	--	--	--	--	--	--	Yes	--	
Lasthenia glabrata	Yellow Rayed Goldfields	--	--	--	--	--	--	Yes	--	
Layia platyglossa	Tidy Tips	--	--	--	--	--	--	Yes	--	
Lupinus bicolor	Miniature Lupine	--	--	--	--	--	--	Yes	--	

Table 2.5-2 VILLAGE-WIDE PLANT PALETTE

BOTANICAL NAME	COMMON NAME	CHARACTERISTICS								
		TYPE	HEIGHT	WIDTH	CROWN	SIZE	SPACING	DT	NATIVE	
<i>Lupinus nanus</i>	Sky Lupine	--	--	--	--	--	--	--	Yes	--
<i>Nemophila menziesii</i>	Baby Blue Eyes	--	--	--	--	--	--	--	Yes	--
<i>Phacelia campanularia</i>	California Desert Bluebells	--	--	--	--	--	--	--	Yes	--
<i>Sisyrinchium bellum</i>	Blue-eyed Grass	--	--	--	--	--	--	--	Yes	--

Notes

- 1) DT = Drought Tolerant; 2) Yes* = Drought tolerant after establishment
- 3) Plant Type:
C = Conifer, D = Deciduous, E = Evergreen, P = Palm
- 4) Most grasses in the *Leymus* genus are rhizomatous and can spread outward in an invasive fashion
- 5) Flowers and seed heads on ornamental grasses often extend beyond the basic height and width dimensions



This page intentionally left blank.



Calodendrum capense (Cape Chestnut)



Jacaranda mimosifolia (Jacaranda)



Olea europaea (Swan Hill Olive)



Tipuana tipu (Tipu Tree)

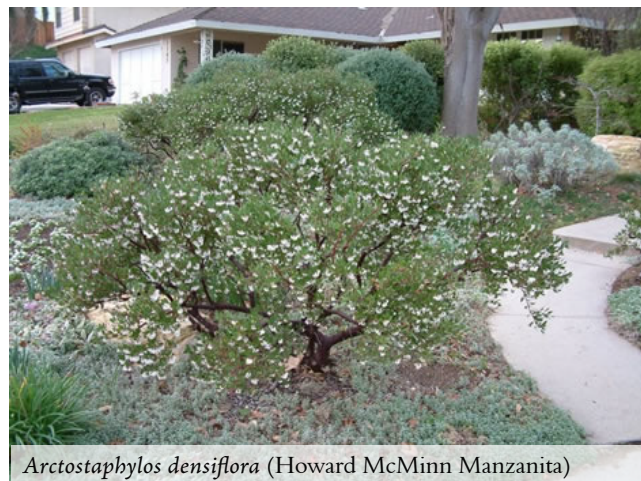

Arcostaphylos densiflora (Howard McMinn Manzanita)



Heteromeles arbutifolia (Toyon)



Myrsine africana (African Boxwood)



Tecoma stans (Yellow Bells)



Aloe (Aloe)



Dasylirion quadrangulatum (Mexican Grass Tree)



Lavandula (Lavender)

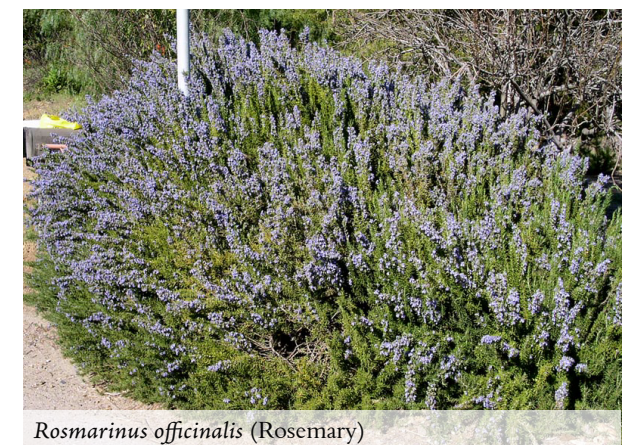

Rosmarinus officinalis (Rosemary)

Figure 2.5-23



This page intentionally left blank.



Carex divulsa (Eurasian Grey Sedge)



Helictotrichon sempervirens (Blue Oat Grass)



Muhlenbergia rigens (Deer Grass)



Chondropetalum tectorum (Small Cape Rush)

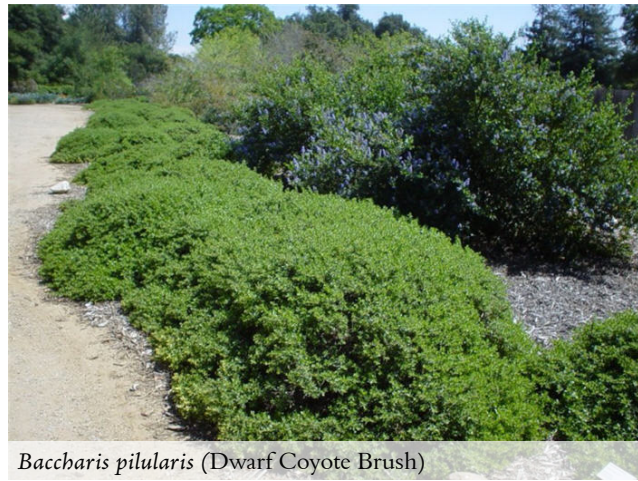

Baccharis pilularis (Dwarf Coyote Brush)



Dymondia margaretae (Silver Carpet)



Pelargonium peltatum (Ivy Geranium)



Rosa banksiae (Lady Banks Rose)



Achillea millefolium (Common Yarrow)



Lasthenia glabrata (Yellow Rayed Goldfields)



Nemophila menziesii (Baby Blue Eyes)



Sisyrinchium bellum (Blue-Eyed Grass)

Figure 2.5-24



This page intentionally left blank.

to life. General streetscape policies that apply to streetscapes within CENTRAL VILLAGE are provided below.

A. General Streetscape Design

The streetscapes within CENTRAL VILLAGE focus on size, scale, landscaping, and traffic calming features to encourage pedestrian activity and safe travel for motorists, transit riders, pedestrians, and cyclists. High density residential uses in combination with commercial uses, particularly in the heart of the CENTRAL VILLAGE, provide the activity needed to bring the streets to life. General streetscape policies that apply to all streetscapes within CENTRAL VILLAGE include the following:

Policy 2.5-80 Provide lighting along the roadway, including pedestrian lighting along sidewalks in the public right-of-way. Lighting elements help contribute to a safe and vibrant street life and allow for nighttime activities. Lighting within the public right-of-way should be maintained by a master maintenance association (MAA) or other similar private maintenance entity. Please refer to Section 3.11, *Maintenance*.

Policy 2.5-81 Paving materials along the streetscapes include concrete, asphalt, and accent pavers. Use special paving, or accent paving to define edges of spaces and visually enhance certain areas such as crosswalks or pedestrian thoroughfares.

Policy 2.5-82 Incorporate sustainable design to all streetscapes, where feasible. These standards include incorporating stormwater control and treatment measures through planting and permeable paving, as well as tree planting techniques that maximize growth conditions, improve overall tree health, and increase shade canopy coverage.

Policy 2.5-83 Where feasible, utilize bioswales designed to remove silt and pollution from surface runoff water within landscaped medians (where applicable). Any proposed bioswales within the public right-of-way would be subject to review and approval by the Development Services Department, to the satisfaction of the City Engineer.

Policy 2.5-84 Design bioswales with gently sloped sides filled with vegetation, compost, and/or riprap to channel runoff into the swaled drainage course.

Policy 2.5-85 Design meandering bioswale to maximize water retention and detention in the swale, which aids the trapping of pollutants and silt.

Policy 2.5-86 Bioswales and the plant material within them should be used to treat the runoff before being released into the watershed or storm sewer.



Bioswale within landscaped median.



Policy 2.5-87 All street trees within CENTRAL VILLAGE are predetermined by the Otay Mesa Community Plan Street Tree List (see Otay Mesa Community Plan Appendix B, *Street Tree Plan*).

B. Airway Road Streetscape

Airway Road features three differing streetscape sections. The streetscapes for the portions of Airway Road located east of Heritage Road are depicted on Figure 2.5-25 and Figure 2.5-26 and discussed below. The portion of Airway Road located west of Heritage Road is a bridge that would consist of hardscape elements, only, as previously depicted on Figure 2.3-2.

I. Airway Road – 6-Lane Primary Arterial Streetscape

The following streetscape policies apply to the portion of Airway Road located west of Cactus Avenue and east of Heritage Road.

Policy 2.5-88 Street trees planted within the median and parkways along Airway Road should be consistent with the *Village-Wide Plant Palette* (refer to Table 2.5-2).

Policy 2.5-89 Landscape treatment along Airway Road (Primary Arterial) should be consistent with Figure 2.5-25, *Airway Road Streetscape- 6-Lane Primary Arterial*.

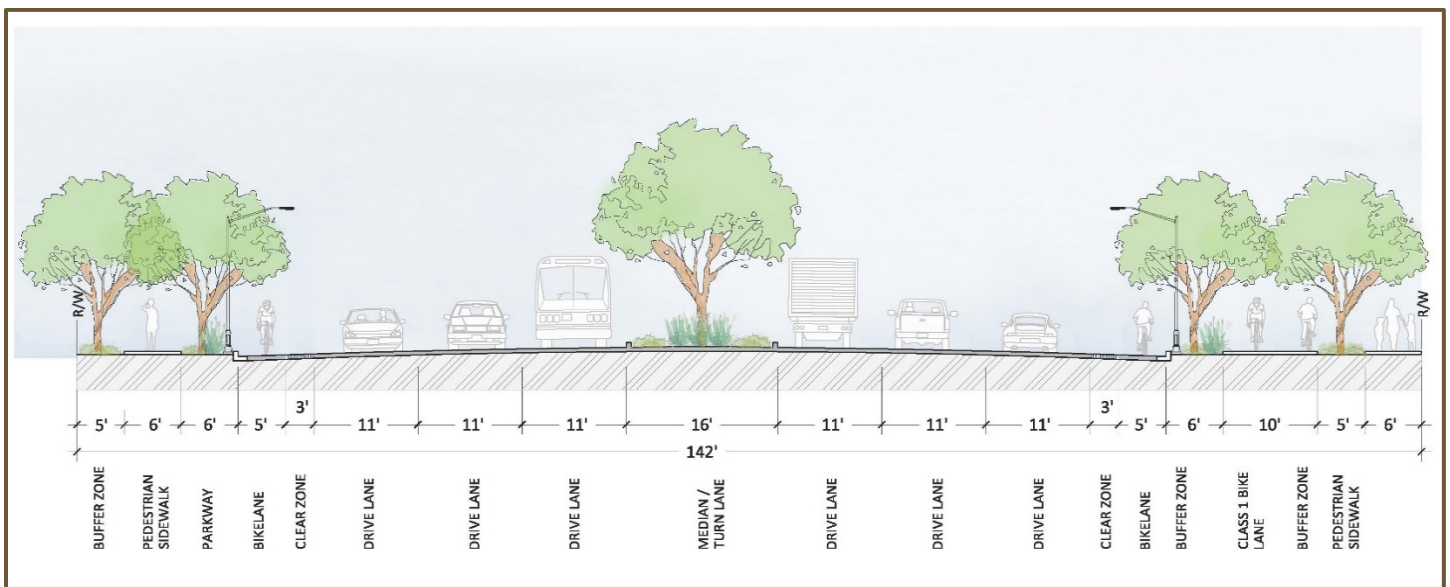

Figure 2.5-25 Airway Road Streetscape- 6-Lane Primary Arterial

II. Airway Road – 6-Lane Major Arterial Streetscape

The following streetscape policies apply to the portion of Airway Road located east of Cactus Avenue and west of Continental Road.

Policy 2.5-90 Street trees planted within the median and parkways along Airway Road should be consistent with the *Village-Wide Plant Palette* (refer to Table 2.5-2).

Policy 2.5-91 Landscape treatment along Airway Road (Six-Lane Major) should be consistent with, Figure 2.5-26, *Airway Road Streetscape – 6-Lane Major*.

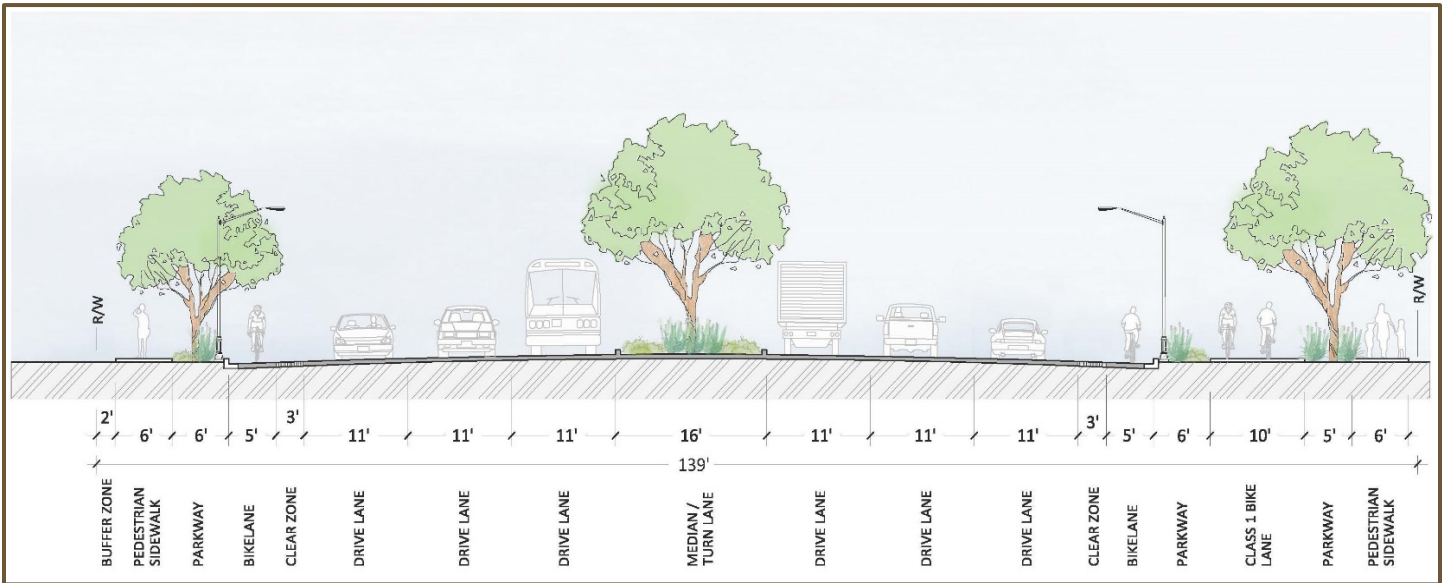

Figure 2.5-26 Airway Road Streetscape – 6-Lane Major

III. *Airway Road – 4-Lane Major Streetscape*

The following streetscape policies apply to the portion of Airway Road located between Heritage Road and the western boundary of the CENTRAL VILLAGE Specific Plan. The portion of Airway Road located west of the CENTRAL VILLAGE will be constructed in the future once a final grade and alignment study is completed for the facility. It should be noted that this segment is intended as the beginning of a bridge over Spring Canyon to the west, and therefore accommodates only hardscape elements.

Policy 2.5-92 Provide concrete barriers and/or fencing along the Airway Road bridge for safety.

C. *Cactus Road Streetscape*

Cactus Road features two different streetscapes. Figure 2.5-27, *Cactus Road Streetscape (South of Airway Road)*, depicts the proposed treatment for Cactus Road south of Airway Road, while Figure 2.5-28, *Cactus Road Streetscape (North of Airway Road)*, depicts the planned streetscape for the portion of Cactus Road located north of Airway Road.



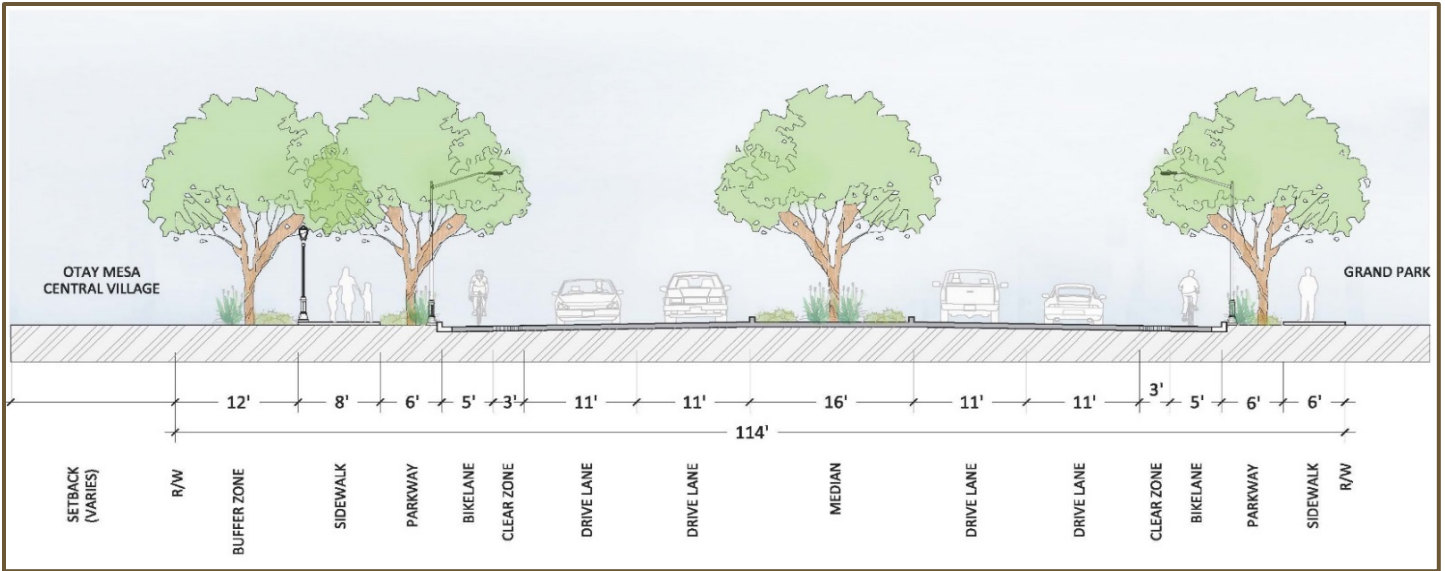

Figure 2.5-27 Cactus Road Streetscape (South of Airway Road)

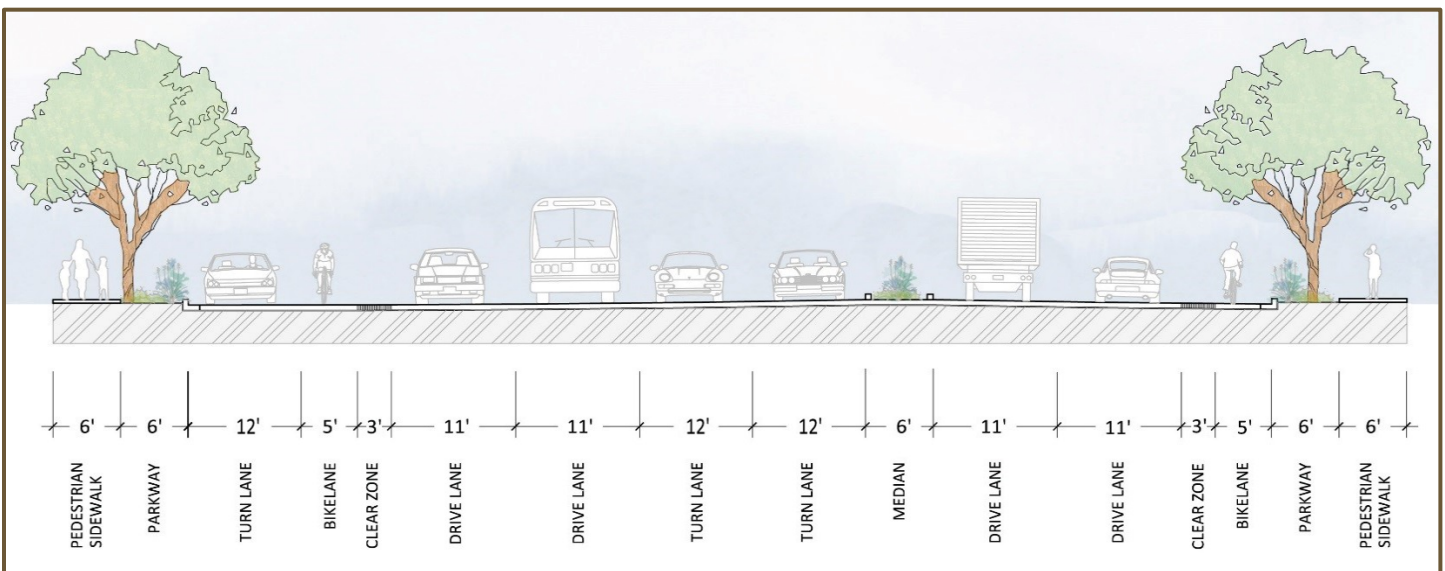

Figure 2.5-28 Cactus Road Streetscape (North of Airway Road)

The following streetscape policies apply to Cactus Road. Implementing developments within the CENTRAL VILLAGE would construct half-width improvements, only, to the segment of Cactus Road between Siempre Viva Road and Airway Road. Full-width improvements would occur to Cactus Road between Airway Road and the northern boundary of Planning Area 9. Between the northern boundary of Planning Area 11 and the northern boundary of Planning Area 9, only half-width improvements would be constructed.

Policy 2.5-93 Traffic calming features, such as bulb-outs, are encouraged at street intersections.

Policy 2.5-94 A special treatment should be provided at the intersection of Cactus Road and Central Main Street to provide safe and convenient non-vehicular access between the CENTRAL VILLAGE and the Grand Park, located east of the CENTRAL VILLAGE, which will be designed pursuant to Council Policy 200-07, the San Diego Street Design Manual, and industry standards, to the satisfaction of the City Engineer.

Policy 2.5-95 Benches along sidewalks to provide pedestrians with comfortable seating are encouraged.

Policy 2.5-96 Street trees planted within the median and parkways along Cactus Road should be consistent with the *Village-Wide Plant Palette* (refer to Table 2.5-2).

Policy 2.5-97 Landscape treatment along Cactus Road should be consistent with Figure 2.5-27 and Figure 2.5-28.

D. Heritage Road Streetscape

The following streetscape policies apply to the segment of Heritage Road located north of Airway Road and within the CENTRAL VILLAGE. This segment also is planned as the entry onto a future bridge across Spring Canyon to the existing improved segment of Heritage Road to the north, and therefore only accommodates hardscape elements. For the portion of Heritage Road located south of Airway Road, the streetscape policies referenced in 2.5.3.2.E for “Green Streets” shall instead apply.

Policy 2.5-98 Landscaping is not required along Heritage Road north of Airway Road within the CENTRAL VILLAGE. This portion of Heritage Road comprises hardscape elements only.

Policy 2.5-99 Provide concrete barriers and/or fencing along the bridge for safety.

Policy 2.5-100 Hardscape treatments along Cactus Road are conceptually depicted on Figure 2.5-29, *Heritage Road Streetscape*.

E. Green Streets Streetscape

Central Main Street and Park Way are designated as Green Streets (Two Lane Collector with Two-Way Left Turn Lane). The following streetscape policies apply to Green Streets.



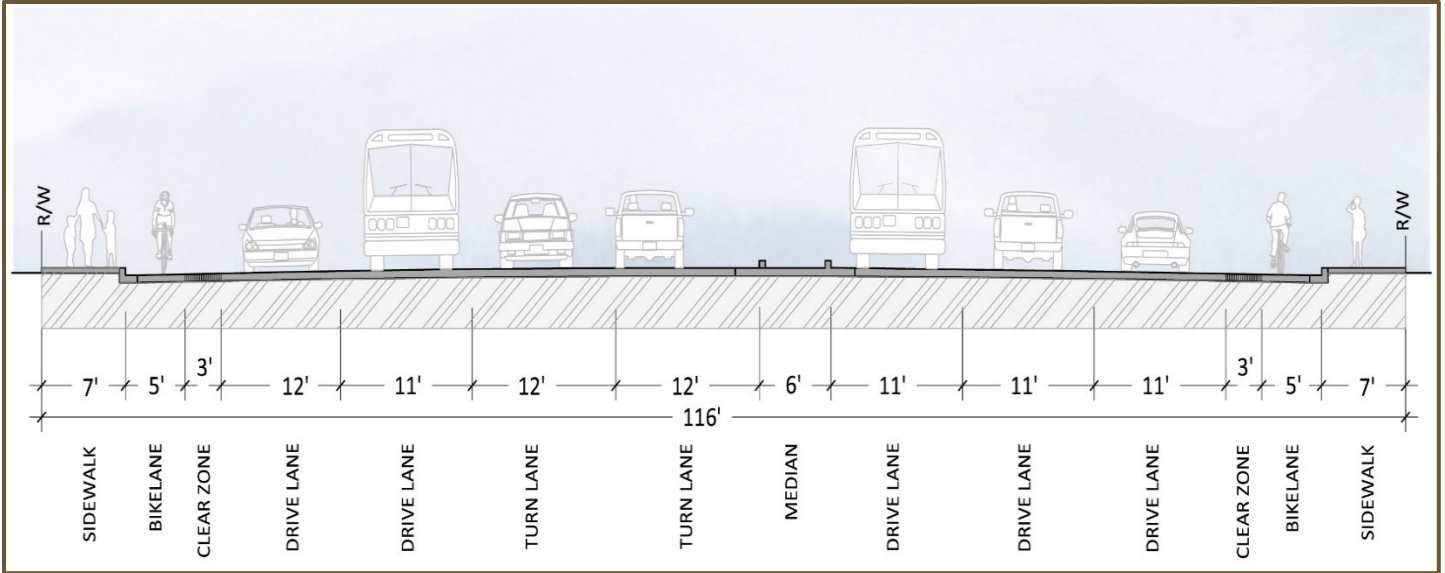

Figure 2.5-29 Heritage Road Streetscape

Policy 2.5-101 The following amenities may be provided to support bicyclists and pedestrians: street furniture, public art, bike paths, multiple access points, and safe street crossing opportunities.

Policy 2.5-102 Public artwork, such as murals or sculptures that do not restrict sight distance for drivers and pedestrians, are encouraged to activate the bulb-out area, as conceptually shown in Figure 2.5-30, *Conceptual Mural at Bulb-Outs Design*.



Figure 2.5-30 Conceptual Mural at Bulb-Outs Design

Policy 2.5-103 Two roundabouts are planned along Central Main Street to enhance safety, maintain traffic flow, and provide aesthetic appeal. One vegetated roundabout is planned where Central Main Street intersects with Heritage Road. A second vegetated roundabout is planned where Central

Main Street intersects with Village Way. A conceptual design for roundabouts within CENTRAL VILLAGE is provided on Figure 2.5-31, *Conceptual Roundabout Design*.

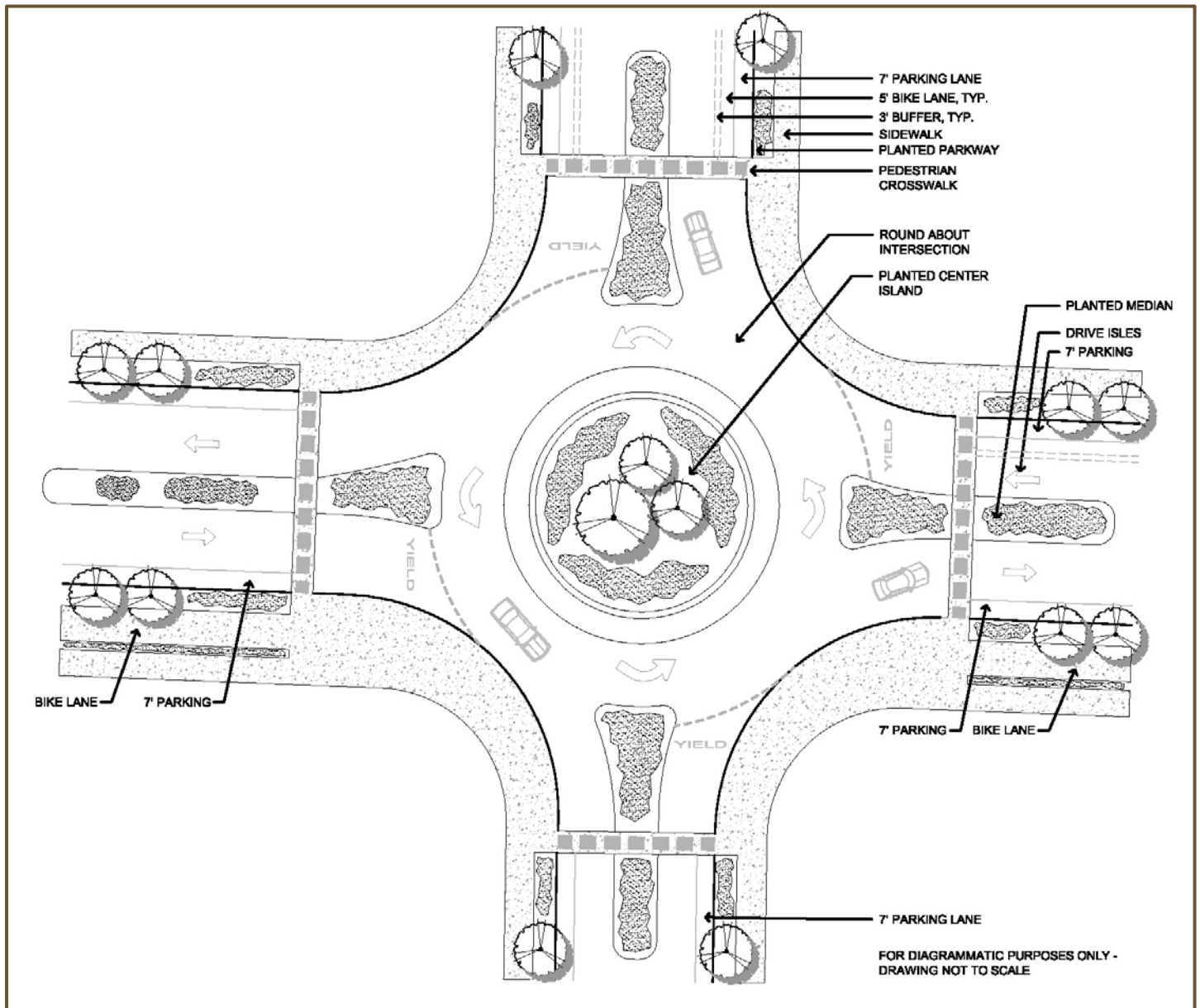

Figure 2.5-31 *Conceptual Roundabout Design*

Policy 2.5-104 The landscape theme of Green Streets features a double row canopy of shade trees on both the right-of-way and adjacent property to soften the effect of adjacent high density residential and commercial buildings and provide for an enhanced pedestrian experience.



- Plant the first row of smaller trees behind the street curb within the parkway and the second row of larger trees within the landscaped strip located adjacent to the right-of-way.
- Each row of trees represents a single species selected from the Otay Mesa Community Plan Street Tree List.

Policy 2.5-105 Street trees planted within the parkways along Green Streets should be consistent with the *Village-Wide Plant Palette* (refer to Table 2.5-2).

Policy 2.5-106 Landscape treatment along Green Streets should be consistent with Figure 2.5-32, *Green Street Streetscape*.

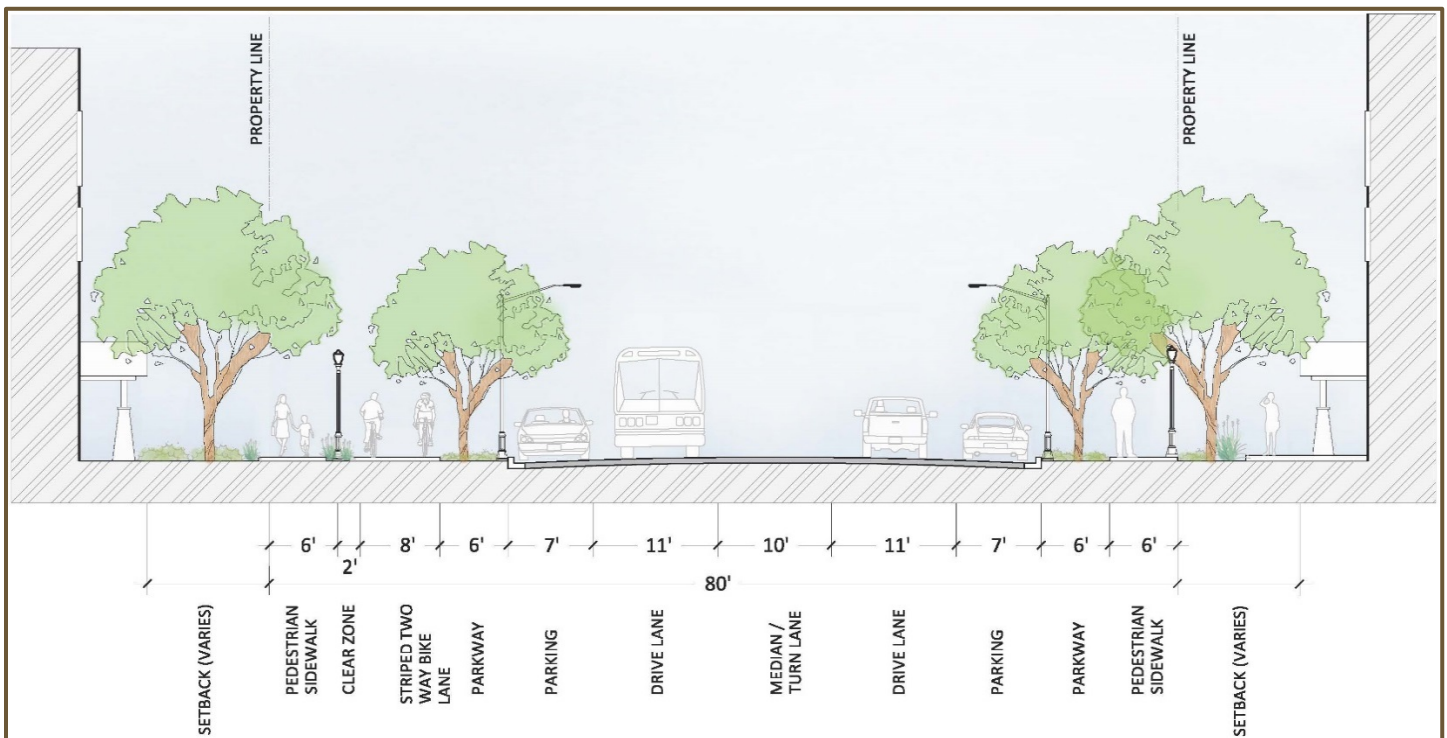

Figure 2.5-32 *Green Street Streetscape*¹

F. Village Entries Streetscape

Heritage Road (between Central Main Street and Airway Road), Village Way (between Central Main Street and Airway Road), Continental Road, and Street D (west of Park Way) are designated as Village Entries (Two Lane Collector with Two-Way Left Turn Lane). The following streetscape policies apply to Village Entries.

¹ Parking on Green Streets, where provided, may be configured as either diagonal or parallel parking stalls. Refer to Figure 2.3-2 for cross-sections of both configurations.

Policy 2.5-107 Provide benches at regular intervals to help activate the street.

Policy 2.5-108 Each roadway features a different theme tree that serves as an identifying element and helps define the character of each street.

Policy 2.5-109 To provide visual interest, an accent tree (a different variety from the same approved list), may be used to compliment the theme tree.

Policy 2.5-110 Street trees planted within the parkways along Village Entries should be consistent with the *Village-Wide Plant Palette* (refer to Table 2.5-2).

Policy 2.5-111 Landscape treatment along Village Entries should be consistent with Figure 2.5-33, *Village Entry Streetscape*.

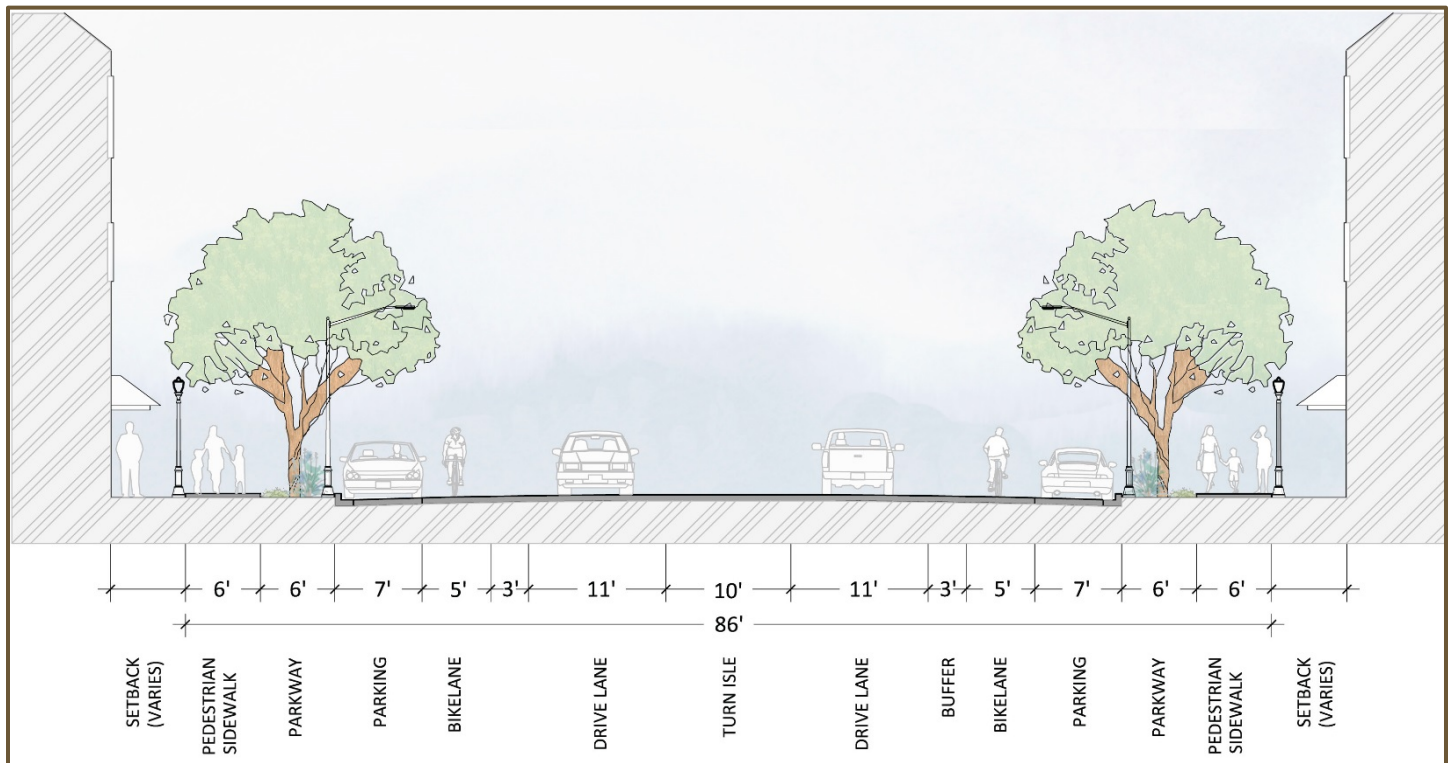

Figure 2.5-33 Village Entry Streetscape

G. Residential Collectors Streetscape

Streets A, B, C, and D (east of Park Way) and Village Way (south of Central Main Street) are designated as Residential Collectors (Two-Lane Collector Street). The following streetscape policies apply to Residential Collectors.

Policy 2.5-112 Each roadway features a different theme tree that serves as an identifying element and helps define the character of each street.



Residential Collector landscape treatment.



Policy 2.5-113 To provide visual interest, an accent tree (a different variety from the same approved list), may be used to compliment the theme tree.

Policy 2.5-114 Street trees planted within the parkways along Residential Collectors should be consistent with the *Village-Wide Plant Palette* (refer to Table 2.5-2).

Policy 2.5-115 Landscape treatment along Residential Collectors should be consistent with Figure 2.5-34, *Residential Collectors Streetscape*.

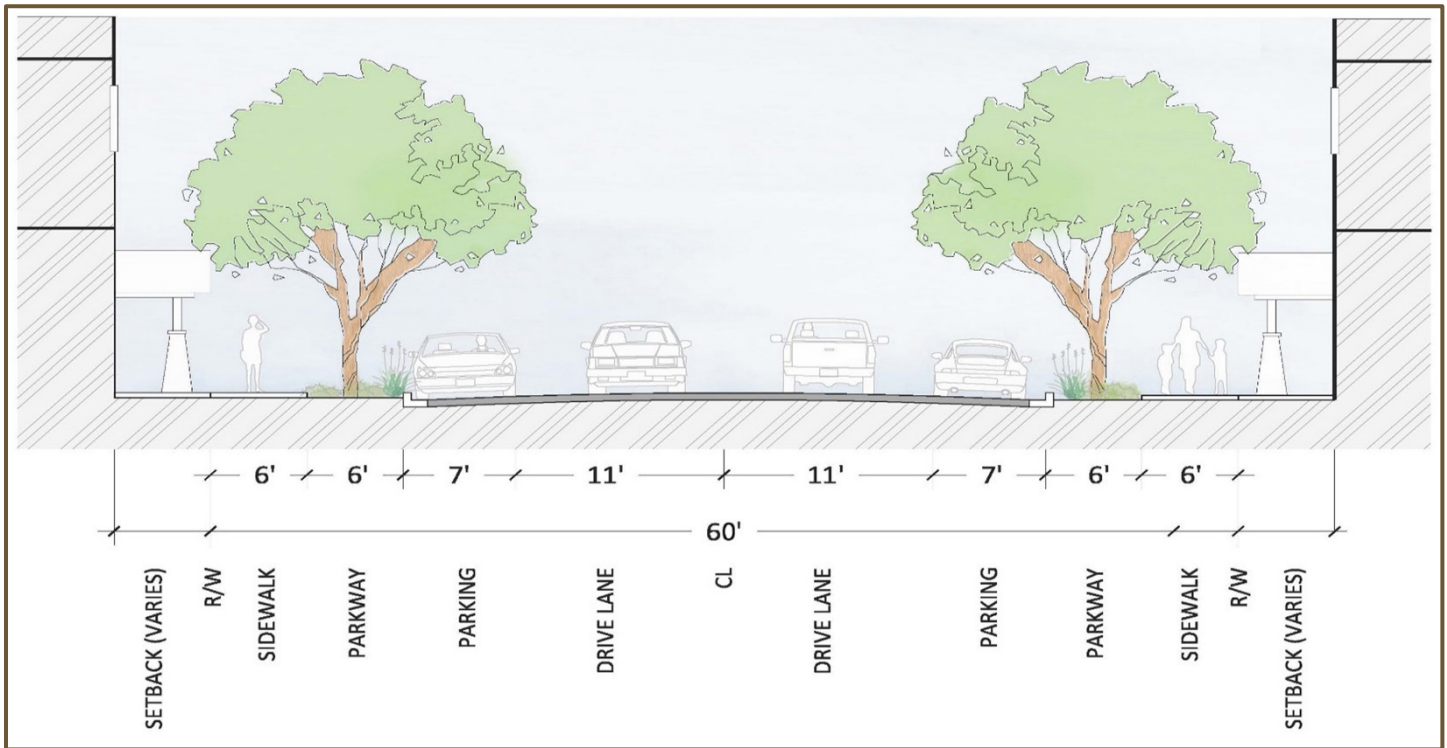

Figure 2.5-34 Residential Collectors Streetscape

H. Private Internal Roadways Streetscape

Private Internal Roadways within CENTRAL VILLAGE are private roadways that provide access within and between the multi-family and mixed use planning areas. The following streetscape policies apply to Private Internal Roadways.

Policy 2.5-116 Landscaping within setback areas located adjacent to sidewalks are limited to the planted identified in the village-wide plant palette (refer to Table 2.5-2, *Village-Wide Plant Palette*).

Policy 2.5-117 Landscape treatment along Private Internal Roadways should be consistent with Figure 2.5-35, *Private Internal Roadways Streetscape (With and Without Optional Parking)*.

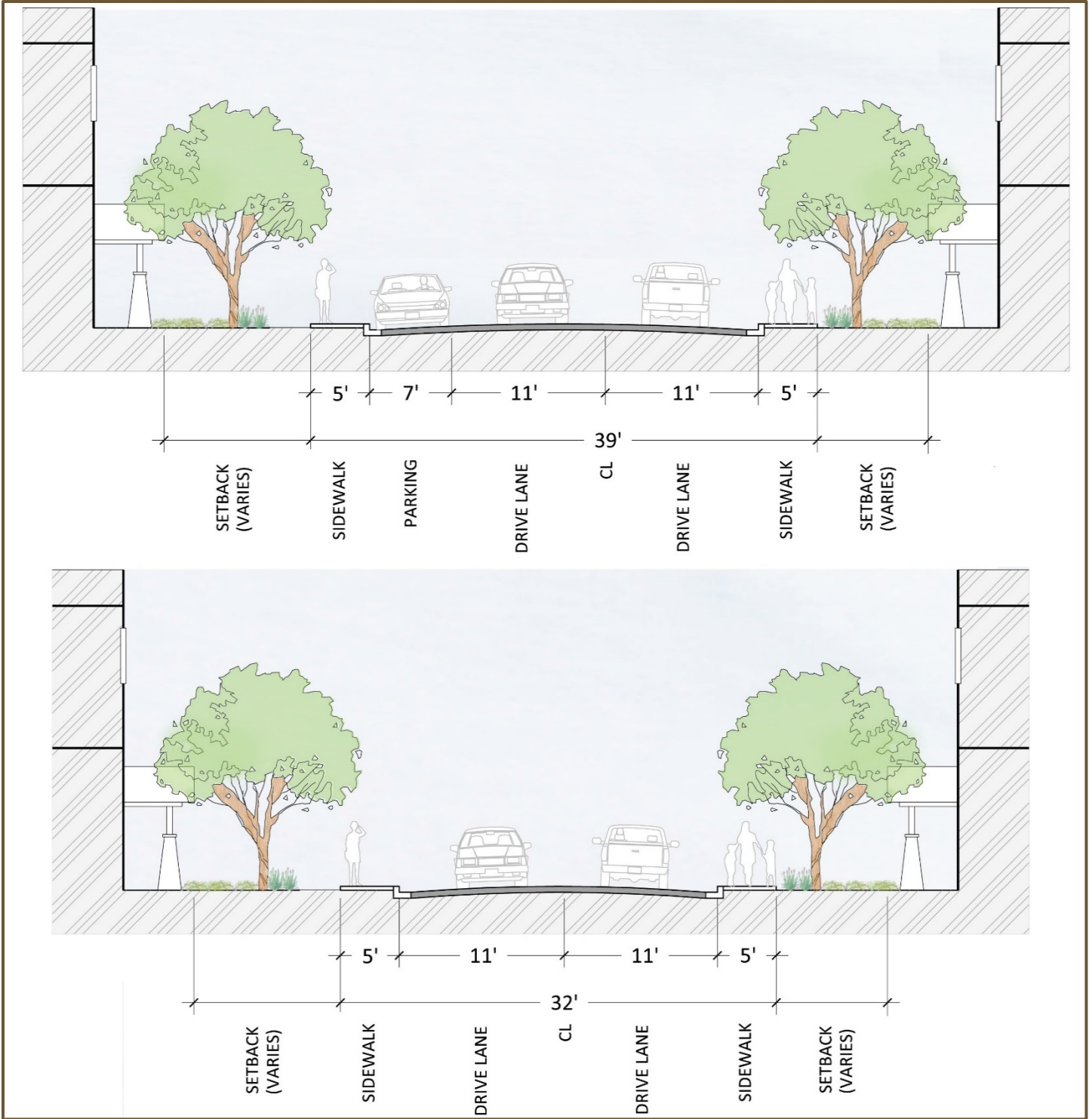

Figure 2.5-35 Private Internal Roadways Streetscape (With and Without Optional Parking)

2.5.3.3 Entries and Monumentation

Entry monuments and signage are important elements that help establish community identity, enhance walkability, and provide wayfinding and



“As design features, monuments, and signage should depict the overall character of the community and respond to the cultural, environmental, and physical context of the neighborhood setting.”

orientation. As design features, monuments, and signage should depict the overall character of the community and respond to the cultural, environmental, and physical context of the neighborhood setting. Ranging in scale from large entry monuments to smaller pedestrian scale signs, the signage and monuments within CENTRAL VILLAGE are designed to be cohesive and well-integrated within the overall community context. There are four types of entries and monuments within CENTRAL VILLAGE including major entry monuments, project identity markers, specific identity markers, and village core intersection monument. The locations of the various entries and monumentation within the CENTRAL VILLAGE are shown on Figure 2.5-36, *Monument Location Map*.

The following policies apply to all entries and monumentation within CENTRAL VILLAGE.

Policy 2.5-118 Except as otherwise may be approved by the City Engineer during Development Services Department’s project review, locate all entries and monumentation outside of the public right-of-way.

Policy 2.5-119 Village Core Intersection Monuments are subject to the regulations for “Community Entry Signs” outlined in Land Development Code § 141.1101.

Policy 2.5-120 Locate and design entries and monumentation to not obscure sight distance and visibility for drivers, pedestrians, and bicyclists.

Policy 2.5-121 The design and character of monuments and signs are drawn from a similar palette of materials, colors, and graphic styles. For example, the use of natural colored monument materials accented by bold colors and graphics are well suited for the CENTRAL VILLAGE.

Policy 2.5-122 All monuments and signs require suitable lighting to make them easy to identify. The design character of monuments, identifiers, and signs proposed for the CENTRAL VILLAGE are based on smaller pinpoint lighting sources that are not visible, and are external to the monuments themselves.

Policy 2.5-123 Landscape treatment at the monuments accommodate the visual clarity of the graphics and compliment the overall monument design setting. The scale and dimension of each of the monument types are designed to provide clear visibility to pedestrians and vehicles from multiple views.

Policy 2.5-124 Incorporate a signage panel and community logo to identify the specific project within the CENTRAL VILLAGE.

Policy 2.5-125 Monumentation should consist of solid materials, such as precision block.

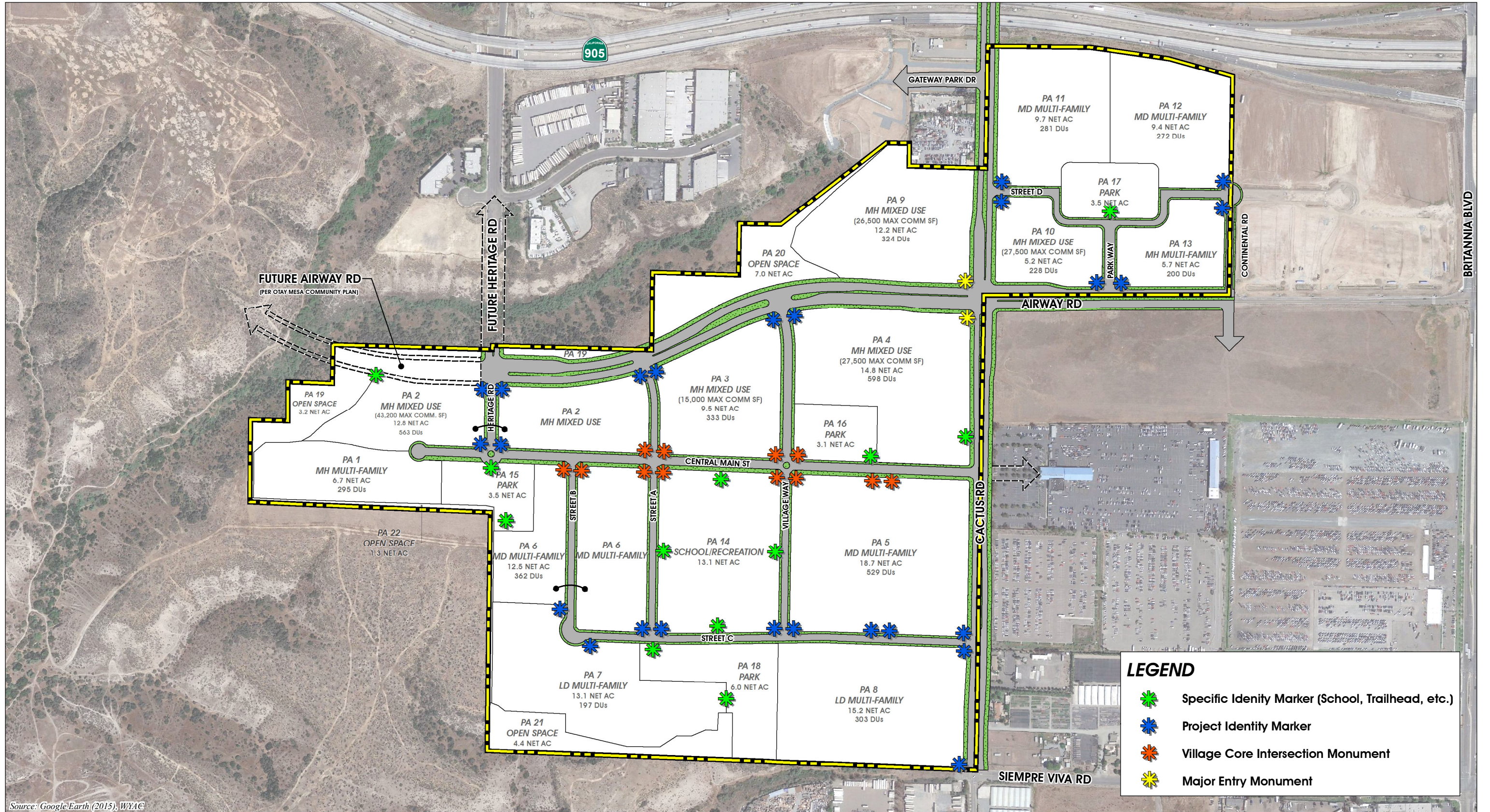

Source: Google Earth (2015), WYAC

Figure 2.5-36

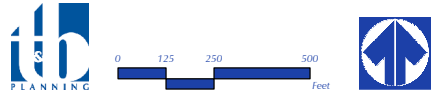

MONUMENT LOCATION MAP



This page intentionally left blank.

A. Major Entry Monuments

Major entry monuments are located at the main intersection to the CENTRAL VILLAGE (Airway Road and Cactus Road) to identify the community and establish the overall character of the village. The iconic effect of a well-designed monument establishes the village’s design theme and evokes a sense of arrival to residents and visitors. The following policies apply to major entry monuments.

Policy 2.5-126 Design major entry monuments to be approximately 6-feet high and 8-feet wide, while still complying with Policy 2.5-120 regarding sight distance.

Policy 2.5-127 Major entry monument should be designed to substantially conform to Figure 2.5-37, *Major Entry Monument*.

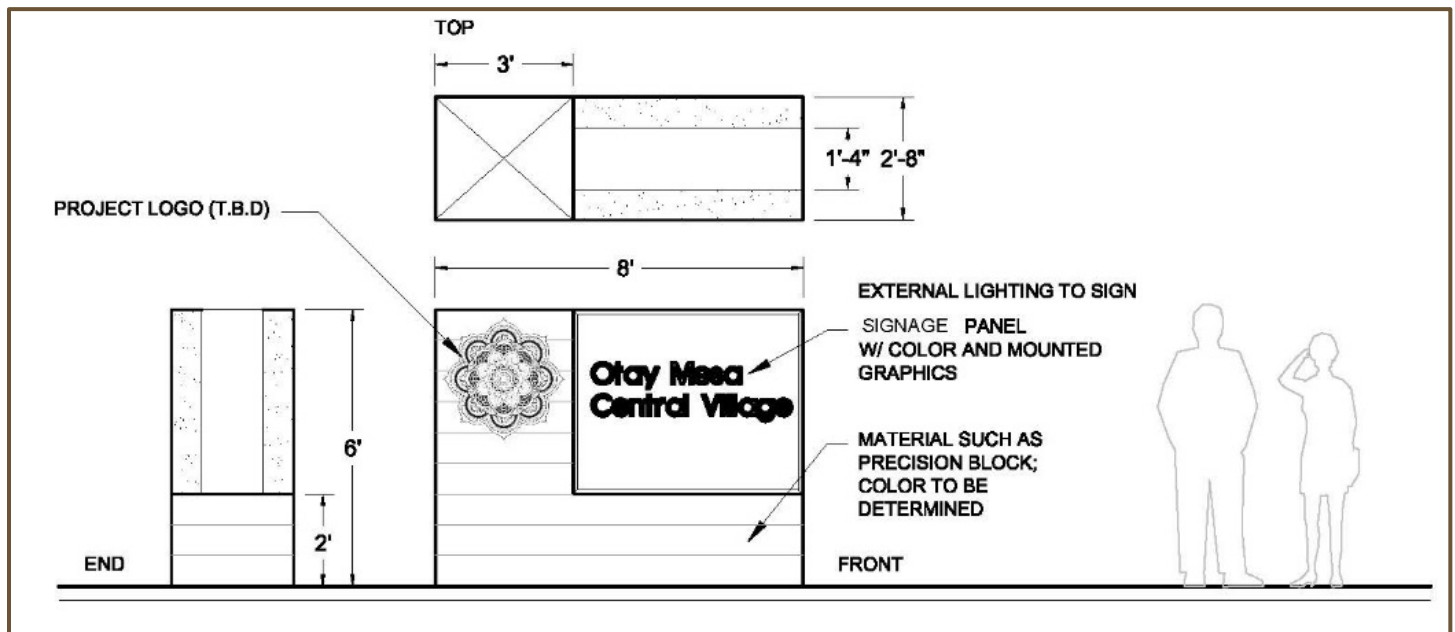

Figure 2.5-37 Major Entry Monument

B. Project Identity Marker

Project identity markers are placed around residential areas and retail and commercial areas. They are designed to complement the major entry monuments and incorporate similar design features, but on a slightly smaller scale. The following policies apply to project identity markers. Incorporate a signage panel and community logo to identify the specific project or area within CENTRAL VILLAGE.

Policy 2.5-128 Project identity markers should be designed to substantially conform to Figure 2.5-38, *Project Identity Marker*.



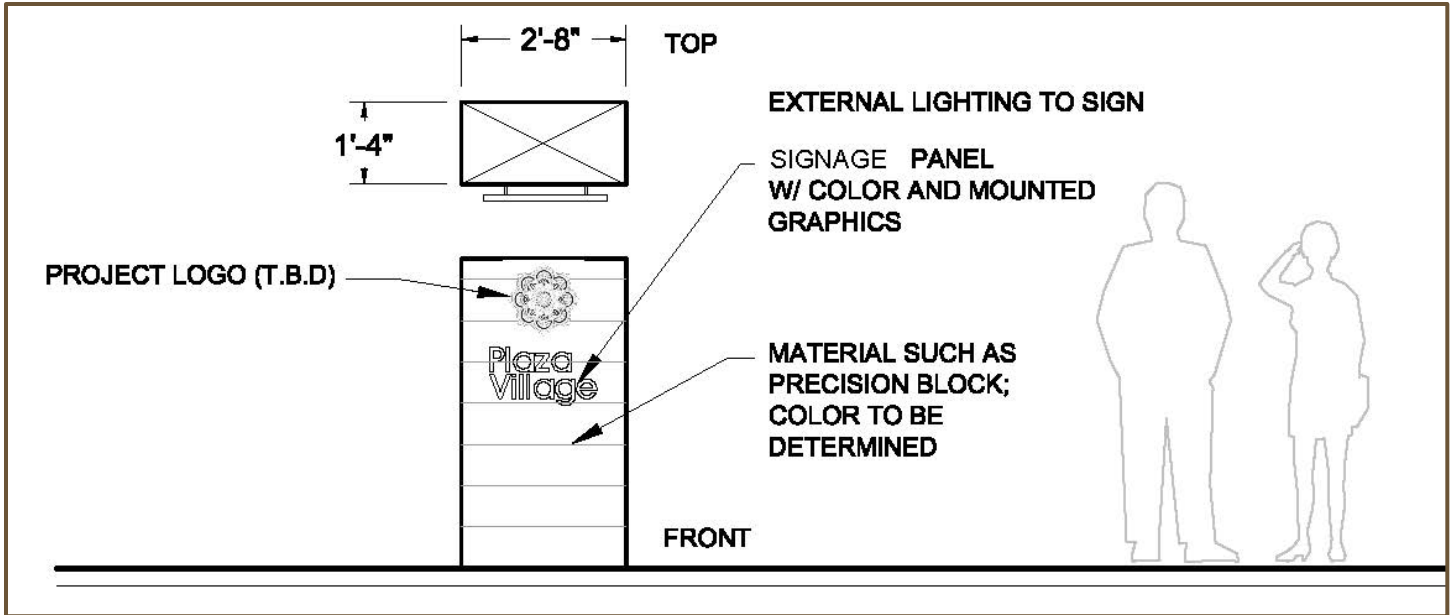

Figure 2.5-38 Project Identity Marker

C. Specific Identity Marker

Specific entity markers are placed at numerous locations within CENTRAL VILLAGE to identify the school and trail heads, and complement the major entry monuments and project identity markers. The following policies apply to specific identity markers.

Policy 2.5-129 Design specific identity markers to be approximately 3.5-feet high and 6-feet wide, while still complying with Policy 2.5-120 regarding sight distance.

Policy 2.5-130 Incorporate public art and/or cultural elements.

Policy 2.5-131 Design specific entity markers to be pedestrian scaled and highly visible.

Policy 2.5-132 Specific entity marker should be designed to substantially conform to Figure 2.5-39, *Specific Identity Marker*.

D. Village Core Intersection Monument

Village core intersection monuments are provided along Central Main Street to enhance the community’s identity and emphasize a sense of arrival into the heart of the CENTRAL VILLAGE. The following policies apply to village core intersection monuments.

Policy 2.5-133 Design intersection monuments to be approximately 6-feet high and contain a 10-foot wide signage panel with color and mounted graphics, while still complying with Policy 2.5-120 regarding sight distance.

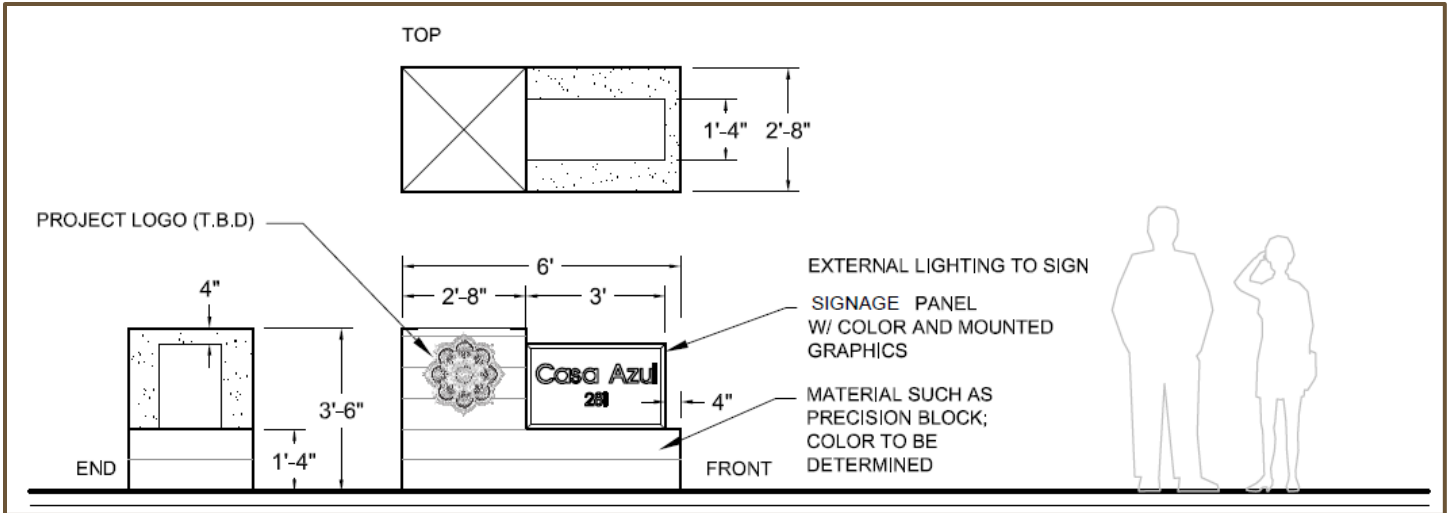

Figure 2.5-39 Specific Identity Marker

Policy 2.5-134 Village Core Intersection Monuments should be designed to substantially conform to Figure 2.5-40, *Village Core Intersection Monument*.

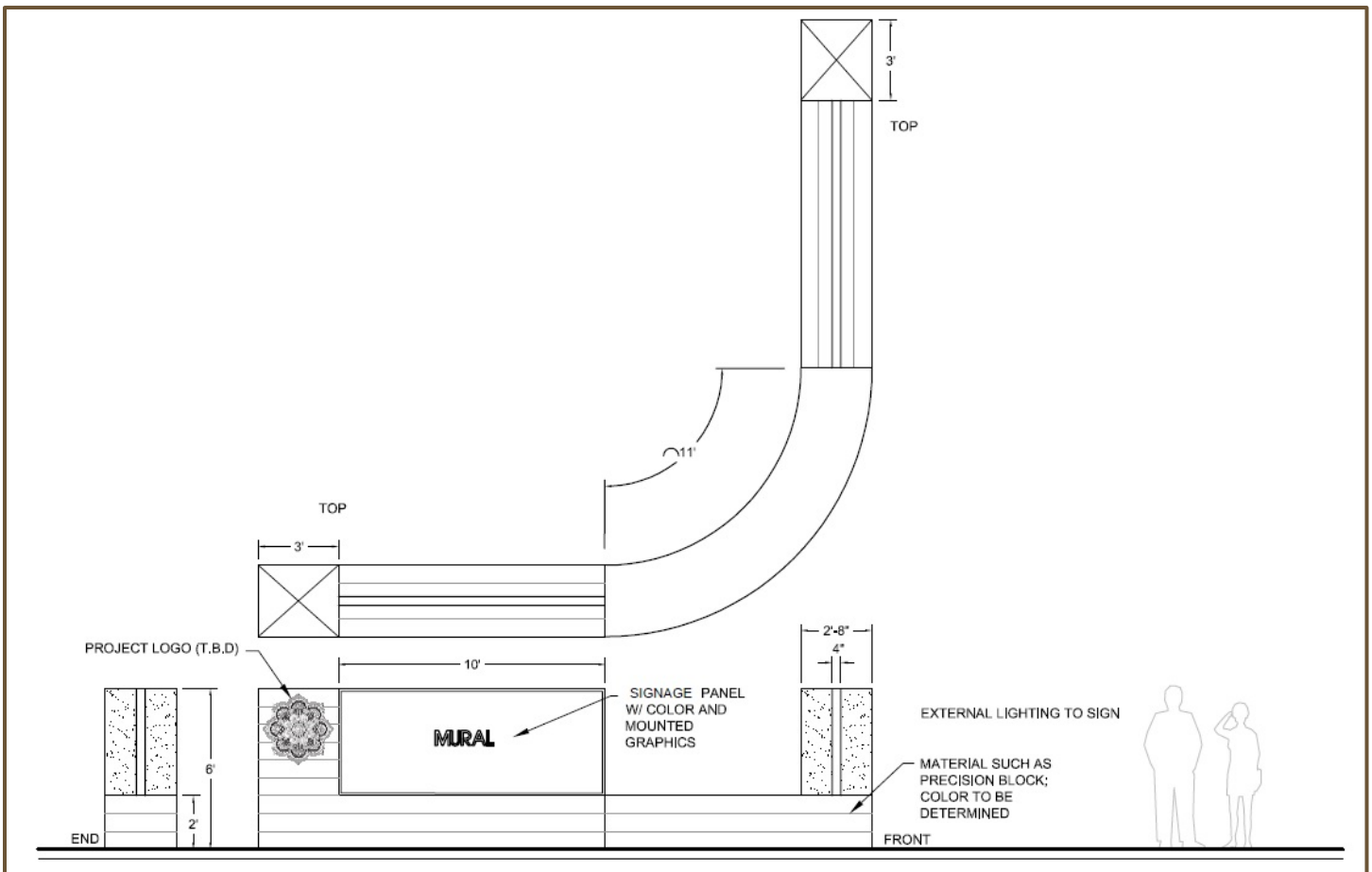

Figure 2.5-40 Village Core Intersection Monument



2.5.3.4 Walls and Fencing

The CENTRAL VILLAGE comprises a number of individual development parcels and land uses including multi-family, commercial, retail, and park uses. Security and controlled access throughout the village will be a tiered design of passive and active barriers including walls, fences, and entry monuments. In addition to providing security, these elements help to unify a community's character and overall design theme. Final locations and the specific design of active and passive barriers are not determined at this phase. The specific design of the walls and fences will be determined during approval of implementing tract maps. However, walls will be located in areas that do not adversely affect non-vehicular mobility within the CENTRAL VILLAGE, particularly the various pedestrian nodes, paseo network, trail connections, trails, and bicycle paths conceptually depicted on Figure 2.3-4, *Alternative Transportation Plan* (previously presented).

The following design standards and policies apply to all walls and fencing within CENTRAL VILLAGE.

Design Standard 2.5-5 Locate and design walls to not obscure sight distance and visibility for drivers, pedestrians, and bicycles as determined by the Development Services Department.

Policy 2.5-135 In order to establish design continuity throughout the CENTRAL VILLAGE, publicly visible walls and fences should be composed of design styles, materials, and colors that are complimentary and consistent with the CENTRAL VILLAGE design theme.

Design Standard 2.5-6 Do not locate walls and fences in areas that obstruct public pedestrian and bicyclist connectivity throughout the CENTRAL VILLAGE, as determined by the Development Services Department.

Policy 2.5-136 Wall and fence Policies are provided for each type of wall and fence provided within the village. These guidelines will be used to determine the final design of walls and fencing to be developed within the CENTRAL VILLAGE.

A. *Masonry Project Theme Wall*

Masonry project theme walls are integral to the identification, wayfinding, and character of development within CENTRAL VILLAGE. The following policies apply to masonry project theme walls.

Policy 2.5-137 Acceptable materials for masonry project theme walls consist of concrete block with a pre-determined masonry styled theme.

Policy 2.5-138 Locate masonry project theme walls where needed to screen from heavy traffic volumes; industrial uses and attendant truck traffic; or where individual development projects require separate identification from each other.

Policy 2.5-139 There is no set dimension or scale to these walls; however, these walls should match and conform to the general design of the overall design theme. A conceptual design of a masonry project theme wall is shown on Figure 2.5-41, *Masonry Project Theme Wall*.

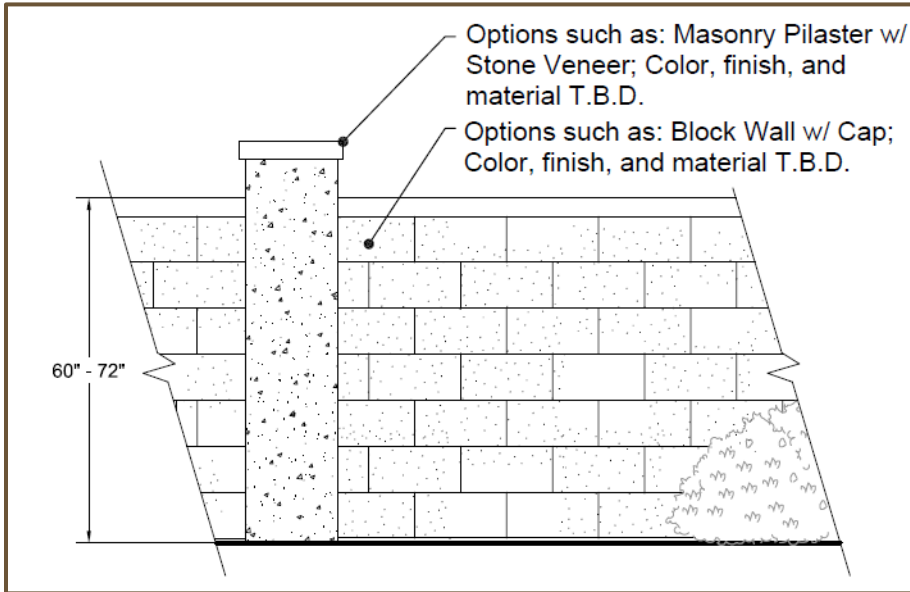

Figure 2.5-41 *Masonry Project Theme Wall*

B. Noise Attenuation Wall

Noise attenuation walls are only used when a minimal sound level standard (decibels) is exceeded due to traffic noise or similar overreaching sound generation. Noise impacts can typically be abated by four basic methods: reducing the sound level of the noise generator, interrupting the noise path between the source and receiver, increasing the distance between the source and receiver, and insulating the receiver (building material and construction methods). All of the methods help to reduce interior noise levels, but only the first three help to reduce outside noise levels (with the exception of aircraft noise). In addition to General Plan Noise Element Policies NE-1.1 through NE-1.4, the following policies also apply to a noise attenuation walls, where required.

Policy 2.5-140 The use of berms, landscaping, setbacks, and architectural design is encouraged where appropriate and effective, rather than conventional wall barriers, to enhance aesthetics.



Policy 2.5-141 Where berms, setbacks, and architectural design are inadequate to achieve required interior or exterior noise levels, physical noise walls may be provided at a maximum height of 120 inches.

Policy 2.5-142 Where noise attenuation walls are required, materials may consist of concrete block, with stone veneer masonry pilaster treatments and a color finish. Materials for the block wall and pilasters will be determined during the tentative map stage.

Policy 2.5-143 Materials and the character of the walls should incorporate thematic elements evident on other walls in the community and/or should be compatible with the overall design theme selected for the CENTRAL VILLAGE.

Policy 2.5-144 Noise attenuation walls, where required, should be designed to substantially conform to Figure 2.5-42, *Noise Attenuation Wall*.

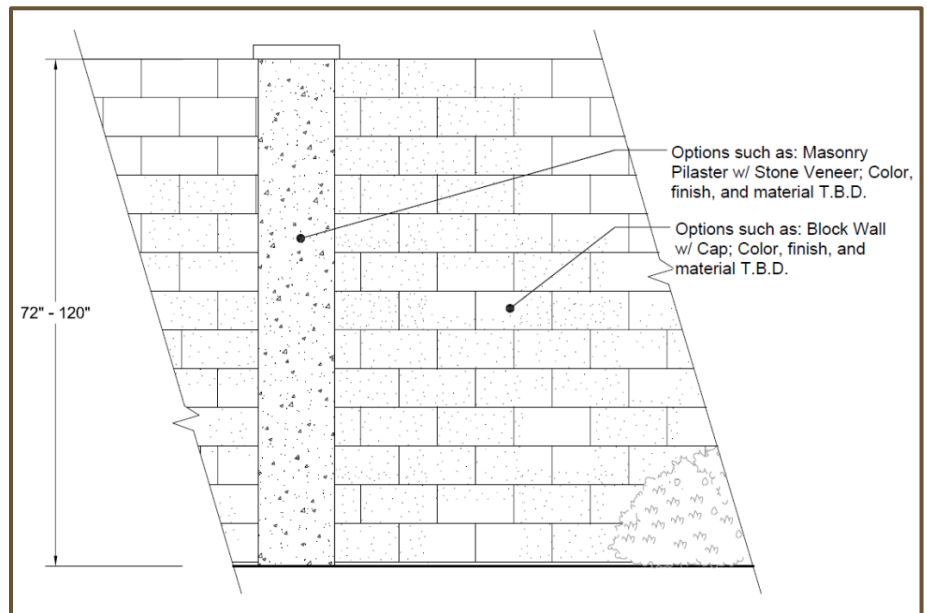

Figure 2.5-42 Noise Attenuation Wall

C. Solid View Wall

Solid view walls provide an active barrier while preserving community character and views. The following policies apply to solid view walls.

Policy 2.5-145 Design solid view walls to range from 60 to 72 inches in height.

Policy 2.5-146 Locate walls where residential areas abut MHPA boundaries to help keep domestic pets from MHPA areas, where required by the MSCP Sub-Area Plan.

Policy 2.5-147 Materials may consist of concrete block for pilasters and 1-hour fire rated solid clear panels for view use. A conceptual design of a solid view wall is shown on Figure 2.5-43, *Solid View Wall*.

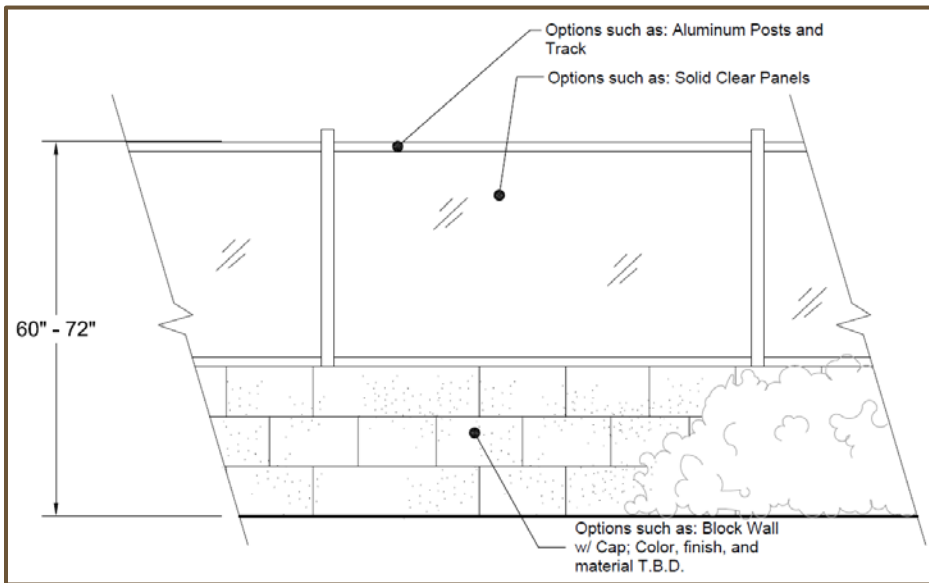

Figure 2.5-43 *Solid View Wall*

D. *Partial View Wall*

Partial view walls are used where views are desirable, but more substantial active barriers are required. The following policies apply to partial view walls.

Policy 2.5-148 Design partial view walls to range from 60 to 72 inches in height.

Policy 2.5-149 Design the top portion of the wall to be open for view use and the bottom portion (one-third of the fence height) of the wall to be solid for screening.

Policy 2.5-150 Residential areas adjacent to open space are encouraged to use partial view fencing along the open space boundary.

Policy 2.5-151 Acceptable materials for partial wall include concrete block tubular metal pickets for the top portion and concrete block for the bottom portion. A conceptual design of a partial view wall is shown on Figure 2.5-44, *Partial View Wall*.

E. *View Wall*

View walls are used to provide an active barrier while preserving the community's character and prominent views. The following policies apply to view walls.



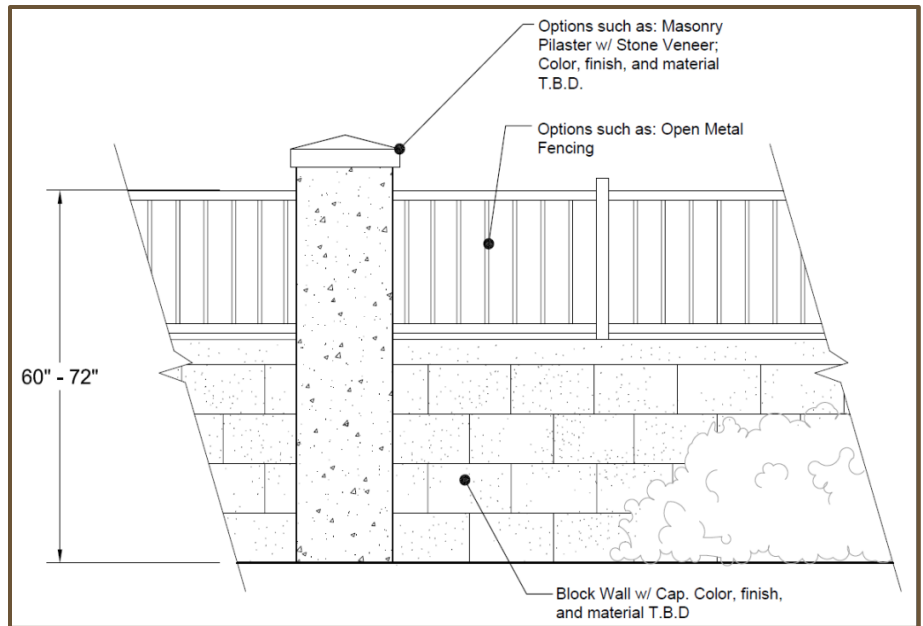

Figure 2.5-44 Partial View Wall

Policy 2.5-152 Design view walls to range from 60 to 72 inches in height.

Policy 2.5-153 Residential areas adjacent to open space areas are encouraged to use non-combustible, 1-hour fire rated view fencing along the open space boundary. Long continuous runs of fencing may be broken up with pilasters, jogs in the fence line, varying heights, and materials, and/or landscaping.

Policy 2.5-154 Acceptable materials for view walls include concrete block for pilasters and open metal fencing for view use. A conceptual design of a view wall is shown on Figure 2.5-45, *View Wall*.

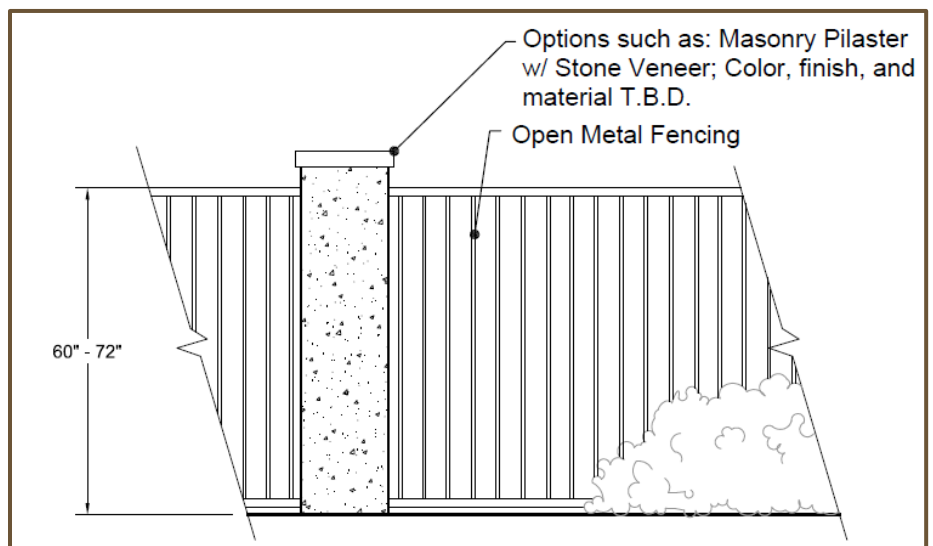

Figure 2.5-45 View Wall

F. Trail and Open Space Fencing

Fencing within the project' open space lots and along project trails provides guidance and controlled access into sensitive preserved habitat areas within and adjacent to CENTRAL VILLAGE. These fences act as passive barriers along trails and preserve and enhance the natural character of the open space areas within and surrounding CENTRAL VILLAGE. The following policies apply to trail and open space fencing.

Policy 2.5-155 Acceptable materials include heavy timber or 1-hour fire rated wood posts and lodge pole type railings.

Policy 2.5-156 A conceptual design of a trail and open space fence is shown on Figure 2.5-46, *Trail and Open Space Fencing*.

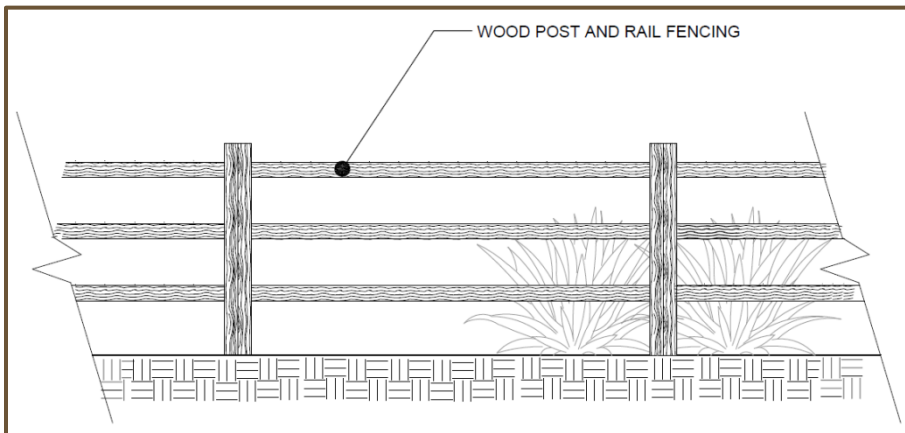

Figure 2.5-46 Trail and Open Space Fencing

G. General Wall and Fencing Policies

Policy 2.5-157 Setback fences and walls a minimum of three feet from the back of sidewalks to provide area for construction and maintenance of footings and allow for landscaping.

Policy 2.5-158 Provide emergency gates at required fire access locations to be determined by the Fire Marshall at the time of final development permit processing.

Policy 2.5-159 Walls and fencing that are required between parks, the school, and residential development sites will be coordinated with the City and the San Ysidro School District to ensure safety measures are addressed for active or passive barrier requirements. The final design of these fence and/or wall locations will be the responsibility of the individual residential developers surrounding each park or school.



2.5.3.5 Brush Management Zones

Brush management zones are required by the City for buildings that are within 100 feet of undisturbed vegetation to reduce fire hazards around structures and to help firefighters protect life and property when fires occur. Brush management zones, where required, shall be provided in a manner consistent with the provisions of San Diego Land Development Code Section 142.0412, as conceptually shown on Figure 2.5-47, *Brush Management Zones*.

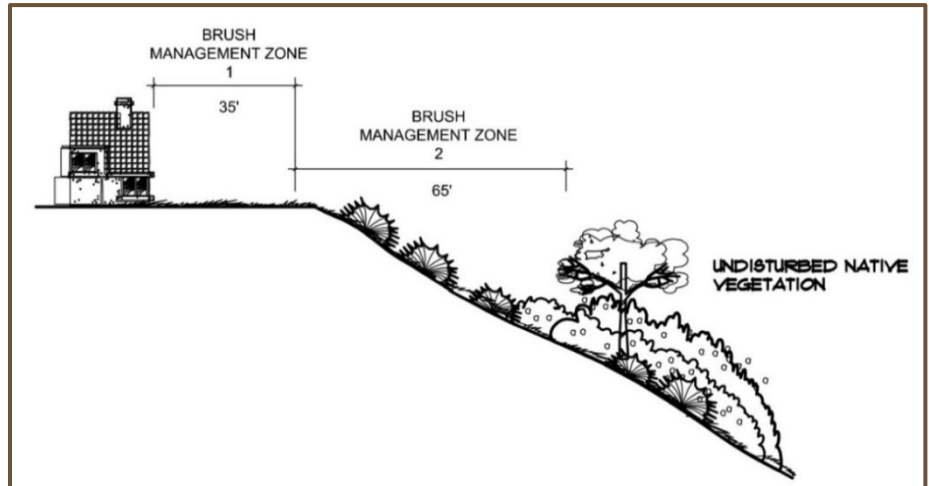

Figure 2.5-47 *Brush Management Zones*

2.5.3.6 Slope Plantings

A. Erosion Control Methods

Erosion control methods are applied to modified slopes located on the perimeter of development (external slopes) and within the development area (internal slopes). These slopes are stabilized to control erosion by utilizing a combination of in place stabilizing methods and new landscape plantings. The following erosion control methods apply to slope plantings within CENTRAL VILLAGE.



Hay wattles located at 15-foot intervals to stabilize slopes and control erosion.

Policy 2.5-160 In place stabilizers should consist of hay wattles, staked in place, and located perpendicular to the grade of the slope at 15-foot intervals.

Policy 2.5-161 Landscaping plantings for external slopes should include a combination of hydro-seeding and container planting of native plant species and should be irrigated on an initial and interim basis (i.e., until the plants are established) through an above grade system. The system should be removed from site within five years of planting and after ample plant establishment is achieved.

Policy 2.5-162 Landscape plantings for internal slopes should include a combination of hydro-seeding and container planting of select low water use ornamental plant species that are irrigated on a permanent basis. The irrigation systems located on internal slopes should be installed below grade. The use of this system should be gradually reduced to periodic operation during severe high temperature periods.

B. Natural Slopes

Natural slopes within and adjacent to CENTRAL VILLAGE are sensitive environmental features that are susceptible to erosion and landslides. Disturbing natural slopes present risks to structures, water quality, and public safety. The following design standards apply to natural slopes within CENTRAL VILLAGE.

Design Standard 2.5-7 Natural slopes shall be protected in place, where feasible. If unstable soil conditions occur, the use of hay wattles, as described under erosion control methods (see Section 2.5.3.6.A), shall be used to stabilize natural slope areas.

Design Standard 2.5-8 Existing slope plantings shall remain in place and supplemental hand planting, such as container plants, and hydro-seeding shall occur as outlined and directed by the project biologist.

Design Standard 2.5-9 Measures must be taken to protect existing planting, including coverage, during the hydro-seeding process and to prevent root zone disturbance.

C. Slope Maintenance

The following design standards apply to slopes within CENTRAL VILLAGE.

Design Standard 2.5-10 Slopes within private lots shall be maintained by the individual property owner.

Design Standard 2.5-11 Slopes within common areas are maintained by a master or single development Homeowners Association or other similar private maintenance entity.

Design Standard 2.5-12 Publically held slopes (not part of private or common area ownership) shall be maintained by a publically funded maintenance district or other similar public maintenance entity.

2.5.3.7 Lighting

Lighting plays an important role in the design of CENTRAL VILLAGE by encouraging walkability, reinforcing community identity, and promoting pedestrian safety in residential and business areas, especially at night time. A well-designed lighting program can also strengthen the village's character



Natural slopes shall be protected in place, where feasible.



and identity through establishing a common thread of light fixtures, placement, and scale of lighting.

The following lighting design standards and policies apply to lighting within CENTRAL VILLAGE.

Design Standard 2.5-13 All lighting adjacent to natural open space shall comply with Multiple Species Conservation Program (MSCP) adjacency guidelines.

Design Standard 2.5-14 Lighting bollards shall not be located within bike facilities or within areas designated for sidewalks. Bollards at the edge of the sidewalk within the landscaped parkway are allowed.

In addition, the following policies apply to lighting within the CENTRAL VILLAGE:

Policy 2.5-163 Provide safe lighting levels with ample ambient coverage to all areas of development.

Policy 2.5-164 Encourage lighting fixtures that conserve energy and reduce long-term maintenance.

Policy 2.5-165 Incorporate simple and authentic materials that are moderate in cost while maintaining a highly durable design character that contributes to the overall design theme of CENTRAL VILLAGE.

Policy 2.5-166 Poles and bases should be integral and comprised of materials such as concrete and metal based materials to provide for a highly durable and clean design at various heights and styles.

Policy 2.5-167 Light fixtures should provide adequate lighting for the safety of community residents and visitors.

Policy 2.5-168 Accessory arms for seasonal banners and community art may be incorporated into the overall design.

Policy 2.5-169 Pedestrian scaled lighting, such as low profile bollards, should be selected from highly durable materials that contribute to the overall design theme of CENTRAL VILLAGE.

Policy 2.5-170 Bollards should be highly durable to withstand impacts from foot and smaller mobility platforms (skateboards) and vandalism.

Policy 2.5-171 Street and parking lot lighting fixtures should match the character of the village and provide a desirable level of illumination.



Bollard fixture along pedestrian pathways.



Accessory arms used to display seasonal banners and community art.

Policy 2.5-172 Park Lighting should be designed to avoid glare for nearby residential areas, and should be consistent with the City's Consultant's Guide to Park Design and Development document

2.5.3.8 Irrigation and Water Conservation

Irrigation water for CENTRAL VILLAGE area will be provided by the Otay Water District. Water resources and distribution are managed by the San Diego County Water Authority (SDCWA). The SDCWA obtains imported water supply from the Metropolitan Water District (MWD).

Development within the CENTRAL VILLAGE will promote overall water conservation through the use of low water use plumbing fixtures, highly efficient irrigation system design standards, and the use of reclaimed water as a non-potable resource if made available to this location. If reclaimed water is made available, it would be utilized as the sole source for the irrigation of parks, open space slopes, schools, parkway landscaping, and multi-family residential common areas, and commercial sites. The use of reclaimed water for irrigation would also allow for the landscape design, composition, and final plant palette selections to use the least amount of water necessary for sustainable development.

Landscape design in CENTRAL VILLAGE addresses current drought conditions and the City's requirements for controlling stormwater run-off and pollution. CENTRAL VILLAGE incorporates green streets as a water conservation method to address drought conditions and stormwater control. Green streets provide optimum conditions for street tree growth integrated with systems that collect and treat runoff water prior to entering the stormwater system, and eventually drain into the canyons, streams, and ocean.

In addition to the requirements set forth in Land Development Code Chapter 14, Article 2, Division 4, the following irrigation and water conservation policies apply to landscaping within CENTRAL VILLAGE.

Policy 2.5-173 Use a combination of drip, bubblers, and spray irrigation methods to avoid overwatering in all planting areas.

Policy 2.5-174 Utilize a drip irrigation system in medians eight-feet wide and smaller and parkway planter areas adjacent to detached sidewalks. The use of turf within these areas is discouraged.

Policy 2.5-175 Water conservation methods, such as harvesting water from building rooftops, condensation from mechanical systems, and gray



water from residential uses, may be incorporated into architectural and building design.

Policy 2.5-176 Incorporate Low Impact Development (LID) controls throughout the CENTRAL VILLAGE.

Policy 2.5-177 Automatically controlled irrigation systems that utilize evapotranspiration monitoring, automatic watering adjustments, night-time water windows, and high-flow monitoring capabilities are encouraged to reduce and manage the community's watering needs.

2.5.3.9 Landscape Maintenance

Policy 2.5-178 Public right-of-way and City-owned park landscapes and facilities requiring a level of maintenance above City standard levels, may utilize a property assessment funding mechanism, such as a Maintenance Assessment District (MAD), for maintenance. The scope of services and method of apportionment to be provided by a MAD would be determined by a qualified assessment engineer, and may be formed at the time the CENTRAL VILLAGE is built. The City should require the developer to sign a Landscape Maintenance Agreement guaranteeing the maintenance of the assets until maintenance responsibility can be transferred to a Homeowners' Association (HOA), MAD, or other entity. Areas outside of the public right-of-way should be maintained by a master association and/or individual residential HOA (see Section 3.11 for a detailed summary of maintenance responsibilities within CENTRAL VILLAGE).

2.6 INFRASTRUCTURE ELEMENT

Infrastructure improvements necessary within the CENTRAL VILLAGE include water, sewer, and storm water drainage systems. These improvements plans ensure that these systems operate efficiently and provide adequate service levels to meet future demand. The infrastructure plans included in this subsection are conceptual and show how water, sewer, and drainage systems will be incorporated into the CENTRAL VILLAGE area and provide adequate levels of service. Therefore, the specifications provided in this subsection may be subject to change based on the outcome of final design and engineering performed at the individual tract map/implementation stage.

2.6.1 WATER AND SEWER

2.6.1.1 Water and Irrigation

As shown on Figure 2.6-1, *Conceptual Water Plan*, the CENTRAL VILLAGE domestic water system is composed of a backbone system within major internal roadways. Water and irrigation service to the CENTRAL VILLAGE would be provided via an existing 10-inch water line in Cactus Road and/or existing facilities within Airway Road (east of Cactus) that include an existing 14-inch water line and an existing 16-inch water line. The CENTRAL VILLAGE Specific Plan accommodates 12-inch water lines within Heritage Road (south of Airway Road), Central Main Street, Streets A through D, Village Way, and Park Way. Airway Road (west of Village Way) also includes a 12-inch water line, although east of Village Way this 12-inch line transitions to a 16-inch line.

Although Planning Areas 1 and 2 are located within the City of San Diego's service area for potable water, the water plan envisioned for the CENTRAL VILLAGE anticipates that water service for the entire 229.2-acre Village will be accommodated by the Otay Water District. Water service for Planning Areas 1, 2, and a portion of Planning Area 15 will be accommodated by a revision of the Otay Water District's service boundaries, or through a service agreement between the City of San Diego and the Otay Water District.

2.6.1.2 Sewer

The CENTRAL VILLAGE sewer plan is depicted on Figure 2.6-2, *Conceptual Sewer Plan*. The CENTRAL VILLAGE utilizes a sewer system to convey wastewater from each planning area within the village toward wastewater treatment facilities. Sewer flows generated in the portions of the site located west of Cactus Road, as well as portions of Planning Areas 10 and



13, would be conveyed to a gravity main located underneath Cactus Road extending from Siempre Viva Road to just north of Street C. Flows from Cactus Road are conveyed to Pump Station 23T located near the intersection of Cactus and Siempre Viva Roads, and are pumped to the Otay Valley Trunk Sewer in Otay Mesa Road. Flows from Planning Areas 11 and 12, as well as portions of Planning Areas 10 and 13, would be conveyed by an existing sewer line extending through proposed Street D, along Continental Road, and within Airway Road east of Continental Road. These flows also ultimately would discharge to the Otay Valley Trunk Sewer in Otay Mesa Road. The on-site sewer mains are located within major internal roadways, and will be sized to adequately convey peak flows generated by the Village. The sewer mains shall be installed at adequate depths to serve all planning areas within the CENTRAL VILLAGE. Prior to approval of a Tentative Map or any other discretionary entitlement approval, a sewer study will be required to analyze its sewer basin and the contribution of others in the basin. The sewer study shall comply with the Public Utilities Department's Sewer Design Guide, latest edition. In cases where an implementing development project is required to install sewer lines at a greater depth and/or at an increased size than is required to service the development for the purpose of accommodating gravity sewer service to another property, the Reimbursement Financing for Water and Sewer Facilities approved in the Otay Mesa Public Facilities Financing Plan (City Council Resolution #R-308811) may be implemented.

2.6.1.3 Water and Sewer Design Standards

The following design standards apply to water and sewer facilities within CENTRAL VILLAGE.

Design Standard 2.6-1 Water service for Planning Areas 1, 2, and a portion of Planning Area 15 is anticipated to be accommodated by a revision of the Otay Water District's service boundaries, or through a service agreement between the City of San Diego and the Otay Water District.

Design Standard 2.6-2 All water and sewer facilities shall be designed per the requirements of the City of San Diego. Facility sizes and locations presented in this Specific Plan are conceptual and may be larger or smaller than indicated on Figure 2.6-1, *Conceptual Water Plan*, and Figure 2.6-2, *Conceptual Sewer Plan*. Additionally, the exact siting of these facilities will be determined through technical studies associated with the processing of future development permits to ensure future development within the CENTRAL VILLAGE complies with the policies and the intent of the CENTRAL VILLAGE Specific Plan.

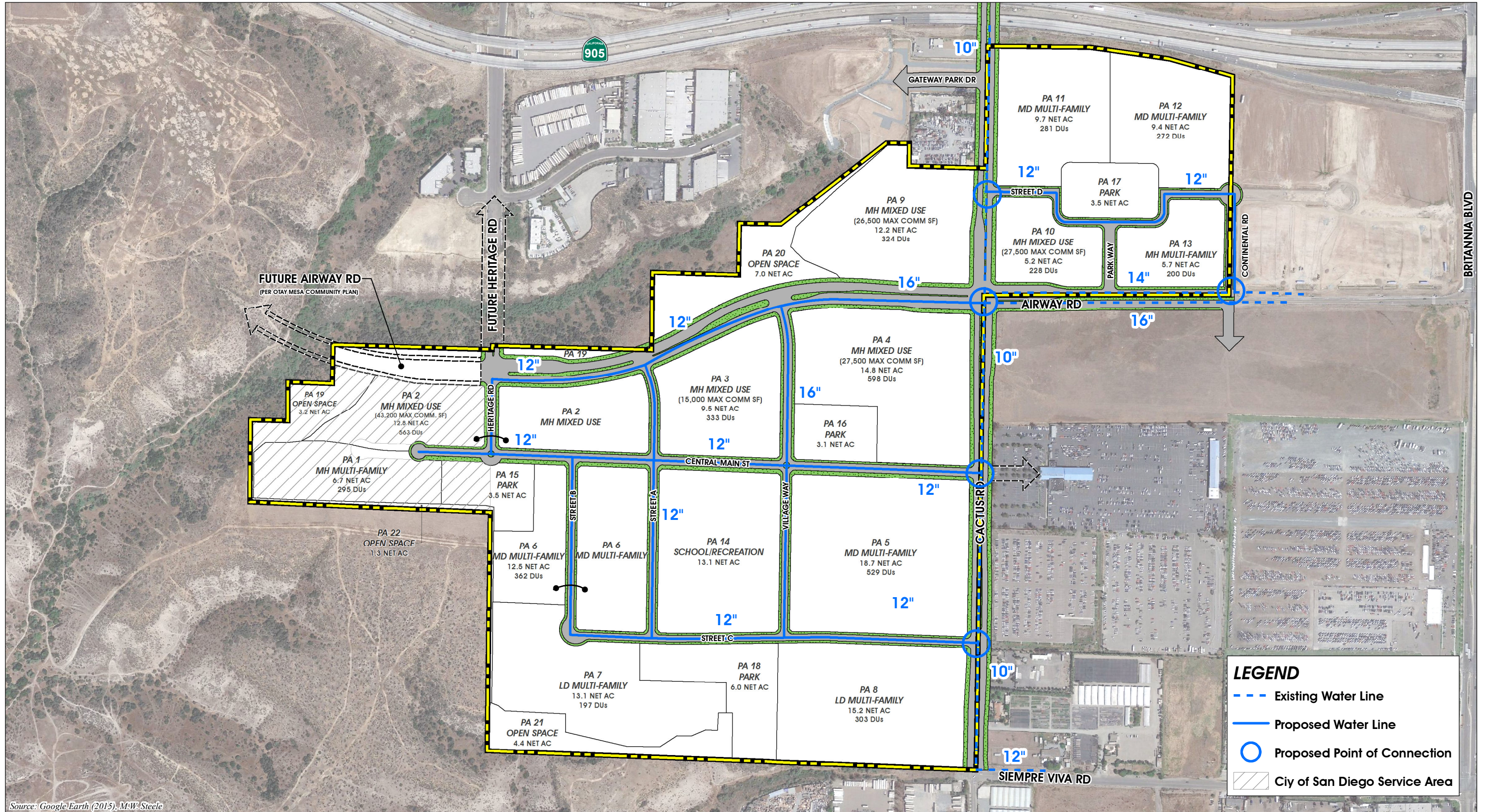

Source: Google Earth (2015), M.W. Steele

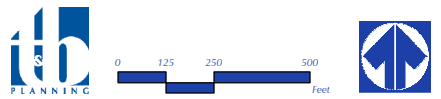
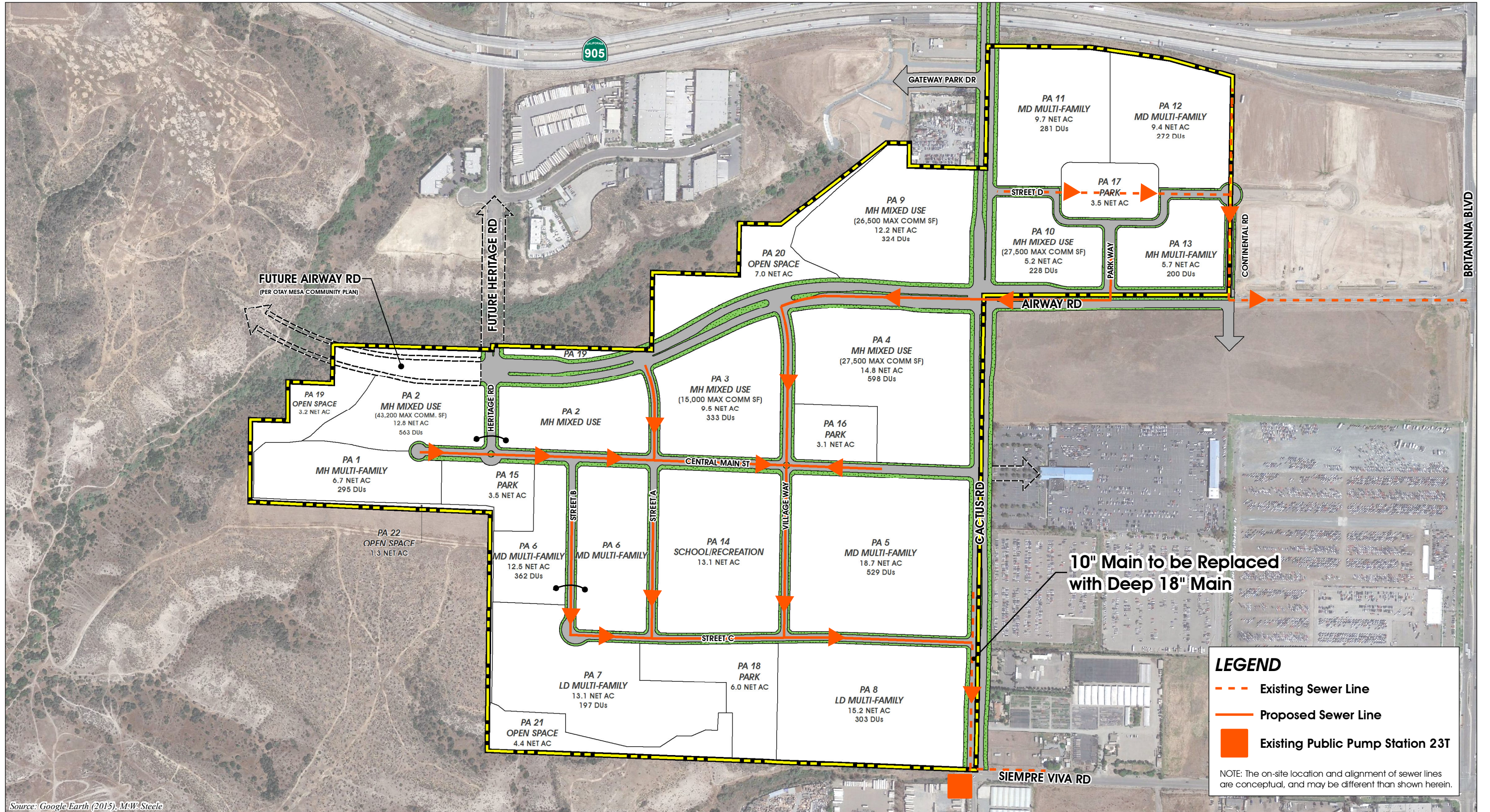

Figure 2.6-1

CONCEPTUAL WATER PLAN



This page intentionally left blank.



LEGEND

- - - Existing Sewer Line
- Proposed Sewer Line
- Existing Public Pump Station 231

NOTE: The on-site location and alignment of sewer lines are conceptual, and may be different than shown herein.

Source: Google Earth (2015), M.W. Steele

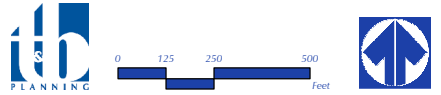

Figure 2.6-2

CONCEPTUAL SEWER PLAN



This page intentionally left blank.

Design Standard 2.6-3 All water and sewer improvements needed to serve each development phase within the CENTRAL VILLAGE shall be in place and fully operational prior to the issuance of occupancy permits.

Design Standard 2.6-4 Water and sewer facilities shall be installed in accordance with the requirements and specifications of the City of San Diego and the State of California, Department of Public Health.

2.6.2 DRAINAGE

Based on a hydrological analysis, the drainage system design for the CENTRAL VILLAGE Specific Plan is illustrated on Figure 2.6-3, *Conceptual Drainage Plan*. The CENTRAL VILLAGE drainage system is designed to utilize the property's natural drainage courses to the extent feasible. Anticipated locations of master storm drain facilities and outfall locations are shown in Figure 2.6-3, although the exact siting of these facilities will be determined during future site planning efforts. Storm drain lines, channels, detention basins, water quality treatment features, and other components of the drainage system shown in Figure 2.6-3 are based on the existing drainage patterns of the Specific Plan area and the anticipated needs of the drainage system.

Best Management Practices (BMPs) will also be incorporated into future implementing projects in accordance with the City's Storm Water Standards, and may include regional-serving BMPs. Mechanical as well as natural treatment control facilities may be used to accomplish water detention purposes and to satisfy Low Impact Development (LID) requirements. The final BMP strategy will be determined during future site planning efforts.

A hydrology study conducted for this Specific Plan recommended five BMP strategy options that implementing projects are to consider, which include:

- 1) Incorporate LID and water pollutant control requirements in a combined LID/biofiltration basin at the downstream end of each regional drainage area.
- 2) Implement LID BMPs in series and provide a downstream water pollutant control BMP at the downstream end of each regional drainage area.
- 3) Implement LID controls on each lot or planning area and in public roadway rights-of-way separately and address pollutant control requirements in a downstream BMP at the downstream end of each regional drainage area.



- 4) Implement both LID controls and pollutant control requirements on each lot or planning area and in public roadway rights-of-way separately.
- 5) Implement controls in any of the above categories and also participate in an alternative compliance project to minimize the necessity of constructing extensive LID controls and water pollutant control BMPs in the CENTRAL VILLAGE area.

2.6.2.1 Drainage Design Standards

In 1987, the City Council approved a contract to prepare the Otay Mesa Master Drainage Plan and published a Notice to “All Private Engineers” that established drainage requirements for development within the East Watershed of Otay Mesa. (Refer to page 2 of the Otay Mesa Community Plan Update [OMCPU] Drainage Study). The Notice required no increase in the rate of stormwater runoff from the property after development, by construction of stormwater detention basins. Most of the drainage analysis associated with the OMCPU Drainage Study focused on the East Watershed, but the OMCPU Drainage Study also addressed the other areas within the CPU boundary. The CENTRAL VILLAGE Specific Plan is within the West Watershed, which is less developed than the East Watershed but still has some of the same drainage challenges. The West Watershed consists of smaller Mesa-top watersheds that drain into the tributary canyons of Spring Canyon. All of the flow from the watershed flows into Mexico at the Spring Canyon concentration point. Although the drainage infrastructure system will be further defined in association with implementing development applications, per Section VII of the OMCPU Drainage report, drainage within the CENTRAL VILLAGE must comply with the following drainage design standards, consistent with the Otay Mesa Master Drainage Plan requirements for the West Watershed (which includes the CENTRAL VILLAGE).

Design Standard 2.6-5 Detention basins shall be required to reduce the post-development peak flows to predevelopment levels for the 50-year and 100-year storm.

Design Standard 2.6-6 If the detention basins concentrate flows at the upper edge of canyons, care must be taken to ensure that erosion potential is not increased downstream.

Design Standard 2.6-7 While developments in the East watershed requires conformance with the Notice to “All Private Engineers”, the West watershed is not subject to the same requirements, but it is subject to the 50-year and 100-year storm detention requirement, as outlined in Design Standard 2.6-5.



Source: Google Earth (2015), M.W. Steele

Figure 2.6-3

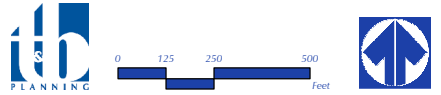

This page intentionally left blank.

Design Standard 2.6-8 The drainage system is obligated to be consistent with the overall goals and design criteria of the Otay Mesa Community Plan Update (CPU) Drainage Study. In particular, the CPU Drainage Study requires detention of post-development peak flows so that runoff is less than or equal to pre-development peak flows for both the 50-year and the 100-year storm.

Design Standard 2.6-9 The drainage system shall conform with the conditions and standards set by the City's "Drainage Design Manual."

Design Standard 2.6-10 The drainage system shall satisfy the requirements of the City's Storm Water Standards Manual.

Design Standard 2.6-11 All projects proposing construction activities including: clearing, grading, or excavation that results in the disturbance of at least one acre total land area, or activity which is part of a larger common plan of development of one acre or greater, shall comply with the appropriate National Pollutant Discharge Elimination System (NPDES) construction permit and pay the appropriate fees. All development within the Specific Plan boundaries shall be subject to future requirements adopted by the City of San Diego to implement the NPDES program. Mitigation measures may include, but are not limited to: on-site retention; covered storage of all outside storage facilities; vegetated swales; monitoring programs; etc.

Design Standard 2.6-12 Incorporate Best Management Practices (BMP) strategies into all future developments as part of site-specific hydrology and water quality studies.

The following policies also apply to drainage within the CENTRAL VILLAGE.

Policy 2.6-1 Incorporate water conservation methods in street design and architectural design to address stormwater control throughout CENTRAL VILLAGE (refer to Section 2.5.3.8).

Policy 2.6-2 Use Low Impact Development (LID) controls where feasible to aid stormwater control.



This page intentionally left blank.

3.0 CENTRAL VILLAGE SPECIFIC PLAN IMPLEMENTATION

3.1 PURPOSE

Approval of this Specific Plan indicates acceptance by the City of San Diego of a general development framework for the CENTRAL VILLAGE. Development of the CENTRAL VILLAGE will be implemented through the City's approval of subsequent Development Permits and approvals that are consistent with this Specific Plan and that meet other applicable City requirements. The implementation process described herein provides the mechanisms for review and approval of permits that will be necessary to implement this Specific Plan.

The implementation approach provides for the orderly development of the CENTRAL VILLAGE, while allowing some flexibility to enable Specific Plan implementers to respond to changes in the economic marketplace and other fluid conditions. The successful implementation of the CENTRAL VILLAGE Specific Plan will require cooperation and coordination among many parties, including but not limited to the City of San Diego, regional, state and federal agencies, property owners and investors, utility providers, the San Ysidro School District, financing and maintenance entities, and design professionals such as engineers, architects, landscape architects and others.

3.2 SEVERABILITY

All regulations, conditions, standards, and guidelines contained in this Specific Plan shall be deemed distinct and independent provisions of the Specific Plan. If any section, clause, phrase, or portion of this document is for any reason determined to be invalid by the decision of any federal or state court of competent jurisdiction, such decision shall not affect the validity of the remaining portions of this Specific Plan.

3.3 ADMINISTRATION

The standards and other requirements of this chapter shall be administered and enforced by the City of San Diego Development Services Department and other City departments in the same manner as the provisions of the City of San Diego Land Development Code (LDC) and in conjunction with the Policies and Design Standards contained in Chapter 2.0 of this Specific Plan. Unless specified otherwise, where the provisions contained herein differ from those in the City of San Diego Land Development Code, the provisions of this Specific Plan shall take precedence. Where the Specific Plan is silent on a topic, the Land Development Code requirements shall remain in force.



3.4 CENTRAL VILLAGE ZONING

3.4.1 PLANNING DISTRICTS

CENTRAL VILLAGE is divided into five planning districts. Planning districts work in concert with the Specific Plan Land Use Plan to establish zoning and development standards for each land use. The location of each planning district is shown on Figure 3-1, *Planning Districts Map*. The Planning Districts are described below.

Planning District 1 is the Moderate to High Density Mixed Use District (MH Mixed Use), which accommodates a mixture of commercial and residential uses integrated either horizontally or vertically. Typically, buildings are medium-scaled and integrated into a vertical and/or horizontal mixed use arrangement. MH Mixed Use areas accommodate medium-scale retail, housing, office, civic and entertainment uses, as well as compact and compatible condominium/ apartment buildings. The MH Mixed Use areas will permit a maximum of 2,046 homes, within an allowable density range of 15 to 44 dwelling units per acre (du/ac).

Planning District 2 is the Moderate to High Multi-Family District (MH Multi-Family), which accommodates multi-family neighborhoods planned near mixed use areas at the western and eastern entrances of CENTRAL VILLAGE. These neighborhoods consist of compact and complementary-designed townhomes and condominium/ apartment buildings. The MH Multi-Family areas will permit a maximum of 495 homes, within an allowable density range of 15 to 44 du/ac.

Planning District 3 includes Low Density (LD) and Medium Density (MD) Multi-Family Zones. LD multi-family residential uses are planned in the southern and northeastern portions of the CENTRAL VILLAGE and allow for the development of small lot town homes and row homes. MD multi-family residential uses are planned in the south-central portion of the CENTRAL VILLAGE, between the LD multi-family neighborhoods in the south and the HD Mixed Use planning areas along Airway Road. These neighborhoods consist of town homes and garden apartments/ condominiums. The LD and MD multi-family areas will permit a maximum of 1,944 homes, within an allowable density range of 10 to 29 du/ac.

Planning District 4 is the Parks District for population based parks. These parks are neighborhood-serving parks, which may include picnic areas, children's play areas, multi-purpose courts and turf areas, paths and

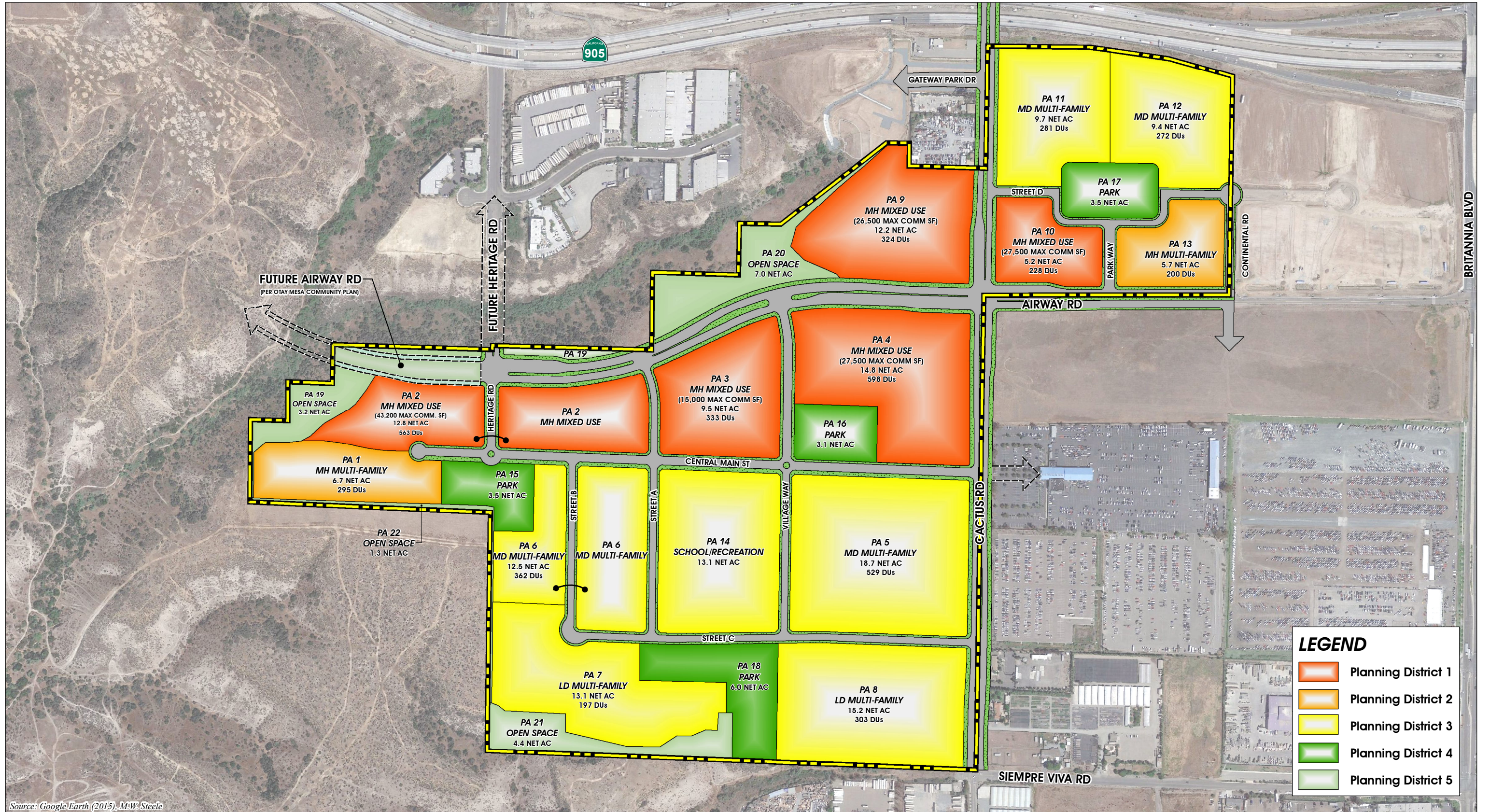
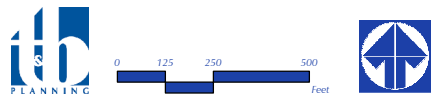

Figure 3-1

PLANNING DISTRICTS MAP



This page intentionally left blank.

walkways, landscaping, and plazas. These parks may also include public art.

Planning District 5 is the Open Space District for open space uses. Open Space areas for natural habitat preservation occur in the same locations and configurations as called for by the Otay Mesa Community Plan. Primarily, natural open space is provided on the canyon and mesa edges in the southwest and northwest portions of the Village. In addition, these areas accommodate scenic overlooks and access to existing trails.

3.4.2 ALLOWABLE USES

A lot or building within the Specific Plan area shall only be occupied by the permitted and conditionally permitted uses allowed by the underlying Base Zone. The Base Zones are listed below and found in the City's Land Development Code, as modified by Section 3.4.3. Table 3-1, *Central Village Specific Plan Supplemental Use Regulations*, identifies the underlying base zones for each of the Planning Districts depicted on Figure 3-1. As shown in Table 3-1, the underlying Base Zone for each Planning District is as follows:

Planning District	Base Zone
Planning District One	CC-3-6
Planning District Two	RM-3-7
Planning District Three	RM-2-5
Planning District Four	OP-1-1
Planning District Five	OR-1-2

Table 3-1 also identifies Use Regulation modifications to the underlying Base Zone for each Planning District. All uses permitted or conditionally permitted by the underlying Base Zone shall apply except as modified by Table 3-1. In cases where Table 3-1 does not list or modify the underlying Use Regulations, the Use Regulations of the underlying Base Zone shall apply pursuant to Chapter 13, Article 1 of the City's Land Development Code.

3.4.3 DEVELOPMENT REGULATIONS

All property within the CENTRAL VILLAGE Specific Plan boundaries is subject to the City of San Diego Land Development Code, including Land Development Code Chapter 13, *Zones*. In addition, applicability of the standards contained in this Section 3.4.3 is specified by both the Planning Districts Map (Figure 3-1) and the land use designations depicted on the Specific Plan Land Use Plan (Figure 2.2-1). Table 3-2, *Central Village Supplemental Development Regulations*, summarizes the development standard requirements that apply throughout the CENTRAL VILLAGE. Additional design standards and policies are



Table 3-1 CENTRAL VILLAGE SPECIFIC PLAN SUPPLEMENTAL USE REGULATIONS

Use Categories/ Subcategories	Planning District 1	Planning District 2	Planning District 3	Planning District 4	Planning District 5
Base Zone (LDC Section Reference)	CC-3-6 (Ch.13, Art.1, Div. 5)	RM-3-7 (Ch.13, Art.1, Div. 4)	RM-2-5 (Ch.13, Art.1, Div. 4)	OP-1-1 (Ch.13, Art.1, Div. 2)	OR-1-2 (Ch.13, Art.1, Div. 2)
LEGEND: P = Permitted by Right; C = Conditional Use Permit Required; -- = Use Not Permitted; L = Limited Use; N = Neighborhood Use Permit Required. Note: Text shown below in bold and italicized fonts represents a modification to the Use Regulations for the Base Zone; text not shown in bold and italics reflect the Use Regulations for the underlying Base Zone (no modifications). Additionally, for any land uses that are identified in the underlying Base Zone but are not referenced below, the Use Regulations of the underlying Base Zone shall apply.					
OPEN SPACE					
Active Recreation	P	P	P	P	--
Passive Recreation	P	P	P	P	p ¹
Natural Resources Preservation	P	P	P	P	P
AGRICULTURE					
Aquaculture Facilities	--	--	--	--	--
Raising & Harvesting Crops	--	--	--	--	--
Raising, Maintaining, & Keeping of Animals	--	--	--	--	--
SEPARATELY REGULATED AGRICULTURE USES					
Commercial Stables	--	--	--	--	--
Community Gardens	L ²	L ²	L ²	L²	--
Open Air Markets for the Sale of Agriculture-Related Products & Flowers	--	--	--	--	--
RESIDENTIAL					
Single Dwelling Units	L³	L³	L³	--	--
SEPARATELY REGULATED RESIDENTIAL USES					
<i>Boarder & Lodger Accommodations</i>	L	L	L	--	--
Companion Units	--	L	L	--	--
Garage, Yard, & Estate Sales	L	L	L	--	--
Guest Quarters	--	--	--	--	--
Home Occupations	L	L	L	--	--
Live/Work Quarters	P	--	--	--	--
Residential Care Facilities:					
6 of Fewer Persons	P	P	P	--	--
7 or More Persons	C	C	C	--	--
Transitional Housing:					
6 of Fewer Persons	P	P	P	--	--
7 or More Persons	C	C	C	--	--
SEPARATELY REGULATED INSTITUTIONAL USES					
Educational Facilities:					
<i>Kindergarten through Grade 12</i>	P	P	P	--	--
<i>Vocational/Trade School</i>	C	--	--	--	--
Electric Vehicle Charging Stations	L	L	L	L	--
Flood Control Facilities	L	L	L	L	--

Table 3-1: CENTRAL VILLAGE SPECIFIC PLAN SUPPLEMENTAL USE REGULATIONS (CONT'D)

Use Categories/ Subcategories	Planning District 1	Planning District 2	Planning District 3	Planning District 4	Planning District 5
Base Zone (LDC Section Reference)	CC-3-6 (Ch.13, Art.1, Div. 5)	RM-3-7 (Ch.13, Art.1, Div. 4)	RM-2-5 (Ch.13, Art.1, Div. 4)	OP-1-1 (Ch.13, Art.1, Div. 2)	OR-1-2 (Ch.13, Art.1, Div. 2)
LEGEND: P = Permitted by Right; C = Conditional Use Permit Required; -- = Use Not Permitted; L = Limited Use; N = Neighborhood Use Permit Required.					
Note: Text shown below in bold and italicized fonts represents modification to the Use Regulations for the Base Zone; text not shown in bold and italics reflect the Use Regulations for the underlying Base Zone (no modifications). Additionally, for any land uses that are identified in the underlying Base Zone but are not referenced below, the Use Regulations of the underlying Base Zone shall apply.					
<i>Satellite Antennas</i>	L	L	L	L	--
Solar Energy Systems	L	L	L	L	--
SEPARATELY REGULATED RETAIL SALES USES					
Farmers' Markets:					
<i>Weekly Farmers' Markets</i>	L	L⁴	--	L⁴	--
COMMERCIAL SERVICES					
Animal Grooming & Veterinary Offices	P	--	--	--	--
Assembly & Entertainment	P	--	--	--	--
<i>With Live Entertainment</i>	N	--	--	--	--
<i>With Outdoor Use Area</i>	N	--	--	--	--
Artist's Studios	P	--	--	--	--
Building Services	P	--	--	--	--
Outdoor Activities	N	--	--	--	--
SEPARATELY REGULATED COMMERCIAL SERVICES USES					
Bed & Breakfast Establishments:					
1-2 Guest Rooms	P	L	L	--	--
3-5 Guest Rooms	P	L	N	--	--
6+ Guest Rooms	P	N	N	--	--
<i>Child Care Facilities:</i>					
Large Family Child Care Homes	L	L	L	--	--
Small Family Child Care Homes	L	L	L	--	--
Golf Courses, Driving Ranges, and Pitch & Putt Courses	C	C	C	C	--
SEPARATELY REGULATED OFFICE USES					
Real Estate Sales Offices & Model Homes	P	P	P	--	--
SEPARATELY REGULATED WHOLESALE, DISTRIBUTION, AND STORAGE USES					
Temporary Construction Storage Yards	N	N	N	N	--
SEPARATELY REGULATED INDUSTRIAL USES					
Mining and Extractive Industries	C	--	--	--	--
SEPARATELY REGULATED SIGN USES					
Neighborhood Identification Signs	N	N	N	--	--
Reallocation of Sign Area Allowance	N	--	--	--	--



Footnotes for Table 3-1:

1. The Director of the Development Services Department or his/her designee will determine if a particular use is appropriate as a passive use in conformance with an approved development plan, park plan, or other plans applicable to the property.
2. Land Development Code Section 141.0203 shall apply, except that on-site sales are not permitted. Community gardens within public parks shall be allowed if recommended through the City's public park development process.
3. Development of a small lot subdivision is permitted in accordance with Land Development Code Section 143.0365. For purposes of this section, the "base zoning" designations for Planning District 1 shall be CC-3-6, the base zoning designation for Planning District 2 shall be RM-3-7, and the base zoning designation for Planning District 3 shall be RM-2-5.
4. Farmers' markets are allowed in parks within the CENTRAL VILLAGE only if recommended through the City's public park development process.

Table 3-2 CENTRAL VILLAGE SUPPLEMENTAL DEVELOPMENT REGULATIONS

DEVELOPMENT STANDARDS	PLANNING DISTRICT:	1	2	3	4	5
	LAND USE DESIGNATION:	MH Mixed Use	MH Multi-Family	LD & MD Multi-Family	Park	Open Space
	BASE ZONE:	CC-3-6	RM-3-7	RM-2-5	OP-1-1	OR-1-2
	ALLOWABLE DENSITY:	15-44 du/ac	15-44 du/ac	10-29 du/ac	--	--

Note: The Development Regulations for the CENTRAL VILLAGE are as established by the underlying Base Zone, except as specifically modified below. Asterisk "*" indicates that the indicated Development Regulations of the OR-1-2 Base Zone shall not apply to open space areas within the CENTRAL VILLAGE. Hyphens "--" indicate no changes to the Development Regulations for the underlying Base Zone; in such cases, the requirements of Land Development Code Chapter 13, Article 1 shall apply for the relevant Base Zone.

Site Requirements	Minimum Lot Area	--	--	1,600 s.f.	--	*
Setback Requirements	Minimum Front Setback	--	--	5 ft.	--	*
	Minimum Side Setback					
	<i>Side Setback</i>	5 ft. ¹	--	--	--	*
	<i>Street Side Setback</i>	--	10 ft. ²	5 ft. ²	--	*
	<i>Alley Setback</i>	--	--	2 ft.	--	*
	Minimum Rear Setback					
	<i>Rear Setback</i>	5 ft.	--	5 ft.	--	*
	<i>Alley Setback</i>	--	--	2 ft.	--	*
	Maximum Floor Area Ratio	2.5	2.5	1.5	--	*
	Maximum Structure Height	75 ft.	75 ft.	45 ft. ³	--	*
	Ground-Floor Height	⁴	--	--	--	*
	Storage Requirements	--	--	Applies ⁵	--	*
	Private Exterior Open Space	Applies ⁶	Applies ⁶	Applies ⁶	--	*
	Common Open Space	25 s.f. per dwelling ^{7,8}	25 s.f. per dwelling ^{7,8}	25 s.f. per dwelling ^{7,8}	--	*
Architectural Projections and Encroachments	Applies ^{9,10}	Applies ^{9,10}	Applies ^{9,10}	--	*	
Supplemental Requirements	Applies ^{11,12,13,14,15,16}	Applies ^{11,12,13,14,16}	Applies ^{11,12,13,14,16}	17	18	

Legend: s.f.= square feet; ft. = feet



Table 3-2 Footnotes:

The footnotes listed herein supersede and replace the footnotes from the City of San Diego Land Development Code Table 131-05E for Planning District 1 and shall supersede the footnotes in Land Development Code Table 131-04G for residential Planning Districts 2 and 3, and shall supersede and replace the footnotes from City of San Diego Land Development Code Table 131-02C for non-residential Planning Districts 4 and 5. Only the footnotes listed herein shall apply to the CENTRAL VILLAGE Planning Districts.

1. Up to 50 percent of the length of the building adjacent to the side yard may abut the side property line, provided that no encroaching element shall exceed 30 feet in length, that encroaching elements are separated by at least 6 feet, and that each dwelling unit has access to either the front or rear of the lot.
2. Up to 50 percent of the building façade length may encroach up to 5 feet into the required street side yard. The encroachment may occur on a floor-by-floor-basis.
3. Land Development Code Section 131.0444 shall not apply.
4. Land Development Code Section 131.0548 shall not apply.
5. Each dwelling unit shall have a fully enclosed, personal storage area that is at least 240 cubic feet with a minimum 7-foot horizontal dimension along one plane. For Planning District 3, the storage area may be accommodated in the garage area and/or in overhead storage within the garage; or in enclosed and lockable closets on balconies/patios.
6. At least 50 square feet of usable, private, exterior open space abutting each dwelling unit with a minimum dimension of 4 feet. The open space may be located in the required front, side, and rear yards.
7. Refer to City of San Diego Land Development Code Section 131.0456 for design requirements for common open space.
8. The minimum width for common open space between buildings is 20 feet.
9. For front and rear yards, encroaching elements shall be separated by at least 10 feet. A minimum setback is not required between the encroachment and the property line. City of San Diego Land Development Code Section 131.0461(c)(4) & (5) for encroachment regulations for garages and non-habitable accessory buildings and projection regulations for dormers shall not apply.
10. For side yards, encroaching elements shall be separated by at least 10 feet. For front and rear yards, encroaching elements shall be separated by at least 10 feet. A minimum of 3 feet must be provided between the encroachment and the property line. Refer to City of San Diego Land Development Code Section 131.0461(c)(4) & (5) for encroachment regulations for garages and non-habitable accessory buildings and projection regulations for dormers.
11. When the ground floor of a building is used for parking and the parking is adjacent to a required yard, the parking area must be screened by a minimum 6-foot-high fence or 6-foot-high landscaping. A pedestrian entry to the building from each street must be provided.
12. For lots with a width of 50 feet or less and buildings facing a public street, at least 40 percent of the length of the building façade on the ground floor must enclose habitable area (not a garage or parking entrance); for lots greater than 50 feet in width and buildings facing a public street, at least 50 percent of the length of the building façade on the ground floor must enclose habitable area.
13. Lots located on a designated Green Street (Central Main Street and Park Way) shall provide landscaped strip with trees planted adjacent to the right-of-way, as shown in Figure 2-10.
14. Where lots are adjacent to open space, setbacks shall include Brush Management Zone 1(See Section 2.5.3.5).
15. Land Development Code Section 131.0540 shall not apply.
16. Land Development Code Section 131.0446(e) & (f) shall not apply.
17. Any structure built within a Planning District 4 lot adjacent to open space shall observe a setback to comply with Brush Management zone regulations.
18. Any structure built within a Planning District 5 lot adjacent to open space shall observe a setback to comply with Brush Management zone regulations.

provided in Section 2.5, *Urban Design Element*, which also apply in addition to the development standards listed in Table 3-2. Any Development Regulation of the underlying Base Zone that is not specifically modified by Table 3-2 shall apply to future development within the CENTRAL VILLAGE.

3.5 CONSTRUCTION AND DEVELOPMENT PERMITS

Applications for Development Permits and Construction Permits, as defined by the San Diego Land Development Code, shall be acted upon in accordance with one of five decision processes established in Chapter 11, Article 2, Division 5 and depicted on Diagram 112-05A of the San Diego Land Development Code.

No Construction Permit shall be issued for the erection, construction, conversion, establishment, alteration, or enlargement of any buildings or structure or for the grading of any site within the CENTRAL VILLAGE until a Neighborhood Development Permit is approved that governs the site. The Neighborhood Development Permit shall be processed in accordance with Process Two as set forth in Land Development Code Chapter 11, Article 2 (Required Steps in Processing) and Chapter 12, Article 6, Division 4 (Neighborhood Development Permit Procedures). However, in the event that implementing Neighborhood Development Permits propose the vacation of dedicated roadway right-of-way, then such applications shall instead be processed according to Process Five, as required by Land Development Code Chapter 12, Article 5, Division 9 (Public Right-of-Way Vacations). Neighborhood Development Permits shall be required in addition to other permits (e.g., Subdivision Maps). All other Development Permits proposed within the CENTRAL VILLAGE shall comply with the applicable requirements of San Diego Land Development Code Chapter 12, *Land Development Reviews*, for the applicable permit type.

The development, maintenance, and operation of previously conforming premises and uses shall be subject to the provisions of Land Development Code Chapter 12, Article 7, Division 1 (Previously Conforming Premises and Uses). Maintenance, repair, alteration, or replacement of a structure with a previously conforming structural envelope is permitted in accordance with Land Development Code §§ 127.0104 through 127.0109.



3.6 TRANSFER OF DWELLING UNITS

The total CENTRAL VILLAGE Specific Plan area shall be developed with a maximum of 4,485 residential dwelling units¹ on 229.2 acres, as illustrated in Figure 2.2-1, *Specific Plan Land Use Plan*. The statistical abstract on Figure 2-1 assigns each residential planning area a “General Plan Land Use,” “Target Dwelling Unit,” and “Target Density.”

The “General Plan Land Use” establishes the minimum and maximum residential density, expressed in number of dwelling units per acre (du/ac).

The “Target Dwelling Unit” total is the maximum number of dwelling units allocated, by right, to each planning area as allocated by this Specific Plan.

The “Target Density” is the target number of dwelling units per acre that are expected in the planning area, considering the permitted du/ac density range for the planning area’s land use designation, and the requirements for the planning area set forth by the design standards and policies contained in this Specific Plan.

The number of dwelling units allowed by each Neighborhood Development Permit may be greater or fewer than the “Target Dwelling Units” allocated to the planning area by this Specific Plan, without necessitating a Specific Plan Amendment provided that:

- a) A “Receiving Planning Area(s)” and a “Donor Planning Area(s)” are identified and included in the application for the Neighborhood Development Permit, and the affected property owners of those planning areas consent in writing to the transfer;
- b) The proposed number of dwelling units in the planning area receiving the density transfer (“Receiving Planning Area”) does not exceed the maximum residential density specified by the planning area’s “General Plan Land Use”;
- c) Following the density transfer, the residential density within the planning area where units would be transferred from (“Donor Planning Area”) does not fall below the minimum density range as specified for that planning area’s “General Plan Land Use”; and
- d) The total number of dwelling units for the entire Specific Plan (4,485 dwelling units)¹ is not exceeded.

¹ In the event Planning Area 14 is developed with residential uses in lieu of school uses, then up to 4,682 dwelling units could be developed within the CENTRAL VILLAGE.

Proposed density transfers may only be allowed if a site-specific traffic impact analysis and water and sewer study are prepared to evaluate what new impacts, if any, could result from the transfer of dwelling units between planning areas within the CENTRAL VILLAGE. The required traffic impact analysis shall identify all improvements needed to achieve an acceptable level of service (LOS) at all study area locations for the development phase in question, inclusive of the proposed transfer of dwelling units. If any impacts not previously disclosed by the Otay Mesa Community Plan Update EIR (SCH No. 2004651076) or a subsequently certified EIR are identified that cannot be mitigated to a level below significant, the proposed density transfer shall not be allowed.

Any implementing development application that proposes a dwelling unit transfer shall be accompanied by a revised tabulation of dwelling unit allocations within the Specific Plan. Revised tabulations shall be shown on each implementing Development Permit application. The tabulations required for each implementing development that proposes a density transfer shall account for the following:

- i) The number of dwelling units allocated to each planning area, if any, as part of approved implementing discretionary actions within the CENTRAL VILLAGE, along with the City's Project Tracking System Numbers associated with each action;
- ii) For planning areas that are not subject to any approved implementing discretionary actions, the number of dwelling units allocated to each planning area by the CENTRAL VILLAGE Specific Plan; and
- iii) A tabulation of the proposed dwelling unit transfer, demonstrating that with the proposed transfer, and in consideration of previously-approved implementing discretionary actions and remaining unit allocations within the CENTRAL VILLAGE Specific Plan, the total number of dwelling units within the CENTRAL VILLAGE will not exceed 4,485 homes¹.

3.7 TRANSFER OF COMMERCIAL SQUARE FOOTAGE

Similar to the transfer of dwelling units, the transfer of commercial square footage as provided in the implementing Development Permit is permitted without requiring a Specific Plan Amendment provided that:

- a) A "Receiving Planning Area(s)" and a "Donor Planning Area(s)" are identified and included in the application for the Neighborhood Development Permit as detailed in Section 3.5 of this Specific Plan, and



the affected property owners of those planning areas consent in writing to the transfer.

- b) A minimum of 5,000 s.f. of commercial use remains allocated to each planning area designated for “High Density Mixed Use” on Figure 2.2-1.
- c) Commercial square footage may only be transferred to planning areas that are designated by the CENTRAL VILLAGE Specific Plan for “High Density Mixed Use” (refer to Figure 2.2-1).
- d) The maximum amount of commercial square footage (139,700 s.f.) for the entire Specific Plan is not exceeded.

Proposed transfers of commercial square footage may only be allowed if a site-specific traffic impact analysis and water and sewer study are prepared to evaluate what new impacts, if any, could result from the transfer of commercial square footage between planning areas within the CENTRAL VILLAGE. The required traffic impact analysis shall identify all improvements needed to achieve an acceptable level of service (LOS) at all study area locations for the development phase in question, inclusive of the proposed transfer of commercial square footage. If any impacts not previously disclosed by the Otay Mesa Community Plan Update EIR (SCH No. 2004651076) or a subsequently certified EIR are identified that cannot be mitigated to a level below significant, the proposed transfer of commercial square footage shall not be allowed.

Any implementing development application that proposes a transfer of commercial square footage shall be accompanied by a revised tabulation of commercial square footage allocations within the Specific Plan (refer to Table 2.2-1, *Maximum Permitted Commercial Area*). The tabulations required for each implementing development that proposes a transfer of commercial square footage shall account for the following:

- i) The amount of commercial square footage allocated to each planning area, if any, as part of approved implementing discretionary actions within the CENTRAL VILLAGE, along with the City’s Project Tracking System Numbers associated with each action;
- ii) For planning areas that are not subject to any approved implementing discretionary actions, the amount of commercial square footage allocated to each planning area by the CENTRAL VILLAGE Specific Plan; and
- iii) A tabulation of the proposed commercial square footage transfer, demonstrating that with the proposed transfer, and in consideration of previously-approved implementing discretionary actions and

remaining commercial square footage allocations within the CENTRAL VILLAGE Specific Plan, the total amount of commercial area within the CENTRAL VILLAGE will not exceed 139,700 square feet.

3.8 MINOR MODIFICATIONS

The following minor modifications to the Specific Plan do not require a Specific Plan Amendment and are subject to review and approval by the Director of the Development Services Department or his/her designee. The decision of the Director of the Development Services Department may be appealed to the Planning Commission pursuant to § 112.0504 of the Land Development Code.

It should be noted that although a formal amendment to the Specific Plan is not required in the following cases, any such minor modifications shall be identified as part of the required Neighborhood Development Permit identified in Section 3.5. Minor modifications to this Specific Plan that would not require an amendment to this Specific Plan include the following:

- ❖ Decrease in overall Specific Plan density and intensity provided that the density and intensity for each planning area remains within the density range of the planning area's General Plan Land Use designation as applied by the CENTRAL VILLAGE Specific Plan.
- ❖ Adjustment in the size of planning areas, provided that:
 - The adjustment results from more accurate estimates of parcel sizes within the CENTRAL VILLAGE;
 - The total acreage of that planning area does not decrease or increase by more than 15% of that stated within this Specific Plan;
 - The resulting density and intensity of development for each planning area remains within the density range of the planning area's General Plan Land Use as applied by the CENTRAL VILLAGE Specific Plan;
 - Any adjustment to park acreage shall be accompanied by an analysis demonstrating that the revised park acreage within the CENTRAL VILLAGE either will not be less than the net useable acreage identified in Table 2.2-1 and Design Standard 2.2-1, or that less parkland acreage is allowed based on any reduction of residential development intensity; and



- Any adjustment to open space acreage shall demonstrate that the revised open space boundaries comply with the open space designations shown within the CENTRAL VILLAGE by the Otay Mesa Community Plan Land Use Plan, unless a Specific Plan Amendment is processed pursuant to Section 3.9 and is subjected to review under CEQA.
- ❖ Transfer of dwelling units between planning areas, as specified in Section 3.6.
- ❖ Transfer of commercial square footage between planning areas, as set forth in Section 3.7.
- ❖ Consolidation of Planning Areas, provided that:
 - The Planning Areas are contiguous;
 - The Planning Areas are within the same Planning District (see Figure 3-1, *Planning Districts Map*) and have the same zoning designation, as shown on the City of San Diego Official Zoning Map;
 - Planning Areas have the same General Plan Land Use designations (see Figure 2.2-1, *Specific Plan Land Use Plan*); and
 - The consolidated Planning Area will have the same development intensity allowance (e.g., number of residential dwelling units and/or commercial square footage) than the total of the individual Planning Areas before they were combined.
- ❖ Any minor modifications of the On-Site Park Development Requirements as shown in Table 3-3 and Table 3-4.
- ❖ Minor changes to or deviations from design standards and policies specified in this Specific Plan, such as paving treatments, architectural details, landscape treatments, fencing, lighting, and entry treatment as determined by the Director of Development Services Department or his/her designee.
- ❖ Final sizing and precise location of water, sewer, storm drainage, and other like infrastructure improvements with concurrence of the City Engineer.
- ❖ Change in utility and/or infrastructure servicing agencies.

- ❖ Landscape, wall material, wall alignment and streetscape design modifications, which substantially conform to the intent of the design standards and policies contained in this Specific Plan as determined by the Director of Development Services Department or his/her designee.
- ❖ Modifications of a similar nature to those listed above, which the Director of the Development Services Department or his/her designee deems minor, which are in keeping with the intent of the Specific Plan and which are in conformance with the vision of the CENTRAL VILLAGE as described in the Otay Mesa Community Plan.
- ❖ Any other proposed changes that are determined by the Director of the Development Services Department or his/her designee to comprise minor modifications.

3.9 FORMAL AMENDMENTS

All substantive Specific Plan modifications, which do not meet the criteria of a Minor Modification as defined in Section 3.8 above, shall be deemed to require a Formal Specific Plan Amendment. In addition, an Amendment of the Specific Plan shall be required in the event residential and recreational uses are proposed in lieu of a school within Planning Area 14. This Specific Plan was prepared pursuant to City of San Diego Land Development Code § 122.0107. Amendments to the Specific Plan shall be processed in accordance with applicable requirements of law.

Formal Amendments shall be processed pursuant to Process Five, as established in Division 5, Article 2, Chapter 11, requiring the review and approval of the City Council. The Planning Commission shall first hear and consider all applications for Formal Amendments to the Specific Plan. The Planning Commission shall prepare a recommendation and findings on all applications for Formal Specific Plan Amendments to the City Council. As required by the California Government Code, all agencies significantly affected by the Formal Amendment shall be notified of the proposed action prior to the approval of the Formal Amendment. In addition, Formal Amendments shall be submitted to the Airport Land Use Commission to provide an Airport Land Use Compatibility Plan (ALUCP) consistency determination.

Any Formal Amendment to this Specific Plan initiated by an applicant shall comply with the applicable procedures and requirements of City of San Diego



Land Development Code § 122.0107, as they relate to proposed revisions to adopted Land Use Plans.

3.10 PHASING

The City shall provide a certain amount of flexibility in the sequence (phasing) of development in the CENTRAL VILLAGE, provided it can be demonstrated that all infrastructure improvements and public facilities required for the phase of development in question are in place or are proposed as part of the implementing project, including any transportation improvements that may be warranted by transportation impact studies required by the City for implementing Development Permits. Given the diversity of ownership and number of property owners within the CENTRAL VILLAGE, it is likely that the CENTRAL VILLAGE will develop in multiple phases over time. Development within the CENTRAL VILLAGE may occur in any order, subject to the following standards:

- 1) Implementing projects shall demonstrate that adequate infrastructure (i.e., water facilities, sewer facilities, storm drain facilities, roadways, and dry utilities) exist to serve the proposed development phase, or that such facilities will be constructed concurrent with the proposed development phase to adequately serve that phase of development. Refer to Specific Plan Section 2.3, *Mobility Element*, for roadway Design Standards and Section 2.6, *Infrastructure Element*, for water, sewer, and storm drain Design Standards.
- 2) A transportation impact analysis shall be prepared for each implementing Development Permit and subdivision to identify the transportation and circulation improvements needed to serve the Development Phase.
- 3) In accordance with Design Standard 2.4-1, on-site recreational areas needed to serve future residents of the CENTRAL VILLAGE Specific Plan shall be developed concurrent with the residential uses as indicated in Table 3-3, *Central Village Park Assumptions*, and Table 3-4, *Central Village On-Site Park Development Requirements – Dwelling Unit Thresholds*. Pursuant to San Diego Land Development Code 142.0640(f) development impact fees may be used for a Developer Reimbursement Agreement for development of the recreational areas identified in the CENTRAL VILLAGE Specific Plan. Any recreational areas that are not

Table 3-3 CENTRAL VILLAGE PARK ASSUMPTIONS						
<i>Planning Areas</i>	<i>Park Planning Area (PPA)</i>	<i>Estimated Dwelling Units</i>	<i>Estimated Population</i>	<i>Total Park Acre Requirement</i>	<i>On-site Park Acre Improvements (At time build out)¹</i>	<i>Grand Park Acres² (Dev. Impact Fee)</i>
1,2	15	858	2,960	8.29	3.50	4.79
3,6,7	18a	892	3,078	8.62	3.20	5.42
4,9	16	922	3,181	8.91	3.10	5.81
5,8	18b	832	2,870	8.04	2.80	5.24
10,11,12,13	17	981	3,384	9.48	3.50	5.98
TOTAL		4,485	15,473	43.34	16.1	27.24

¹ The On-Site Park Development Requirements may be modified with the approval of the City of San Diego Director of the Development Services Department as the result of a delay not within the reasonable control of the Developer. Due to the public park development processes as set forth by Council Policy 600-33, park improvements need not be in place at the time of residential occupancy. Any modification of the On-Site Park Development Requirements shall be made without amending the CENTRAL VILLAGE Specific Plan.

² Grand Park a 36-acre planned park located east of Cactus Road, off-site from the CENTRAL VILLAGE Specific Plan. The Otay Mesa Community Plan Update allocates 27.9 acres of the 36 acre park to the CENTRAL VILLAGE Specific Plan’s parkland requirements.

Table 3-4 CENTRAL VILLAGE ON-SITE PARK DEVELOPMENT REQUIREMENTS – DWELLING UNIT THRESHOLDS¹					
On-Site Park Development Requirements	Park Planning Area (PPA)				
	15	16	17	18a	18b
	Dwelling Unit Threshold				
Park land acquisition shall be completed by: (40% of PPA)	343	369	392	357	333
Park Development Agreement shall be approved by: (65% of PPA)	558	599	638	580	541
Park General Development Plan shall be approved following San Diego City Council Policy 600-33 by: (75% of PPA)	644	692	736	669	624
All park improvements shall be completed and open to the public by: (85% of PPA)	729	784	834	758	707

¹ The On-Site Park Development Requirements may be modified with the approval of the City of San Diego Director of the Development Services Department as the result of a delay not within the reasonable control of the Developer. Due to the public park development processes as set forth by Council Policy 600-33, park improvements need not be in place at the time of residential occupancy. Any modification of the On-Site Park Development Requirements shall be made without amending the CENTRAL VILLAGE Specific Plan.

identified and located within the CENTRAL VILLAGE Specific Plan and that are required to serve future residents, shall be subject to payment of development impact fees to the City of San Diego pursuant to San Diego Land Development Code, to be used by the City to acquire and/or improve public parks. Required parkland shall be calculated per the General Plan standard of 2.8 net usable acres per 1,000 residents, based on the Otay Mesa



Community Plan household population estimate of 3.45 persons per dwelling unit.

The park phasing requirements shall be completed to the satisfaction of the City of San Diego Director of the Development Services Department or his/her designee before residential development is permitted beyond the dwelling unit threshold as specified in Table 3-4, *Central Village On-Site Park Development Requirements – Dwelling Unit Thresholds*.

- 4) Conditions of approval of individual projects (i.e., Subdivision Map, Neighborhood Development Permit) shall include a final internal circulation plan and a final pedestrian mobility plan. Individual projects must be substantially consistent with Specific Plan Design Standards, and demonstrate that both roadways and paseos align in linear a fashion as possible with paseos and roadways planned in adjacent planning areas.
- 5) In the event an implementing development application is filed with the Development Services Department for property internal to the Specific Plan and for which road access to Cactus Road or Airway Road has not already been provided, only frontage improvements of Specific Plan roadways (Figure 2.3-1) shall be required unless the implementing Neighborhood Development Permit's site-specific transportation impact study shows otherwise. Temporary road access may be required to be constructed to minimum City standards from the property to the existing public street network, subject to approval by the City Engineer.
- 6) For applications involving only a portion of a Planning Area that has multiple underlying landowners, the number of units shall be proportionally allocated based on the size of the portion of the Planning Area affected by the applications in relation to the total net acreage for the Planning Area. For example, if a landowner submits applications covering 50% of the total net acreage of a given Planning Area, then the maximum number of units shall be 50% of the number of units allocated to the Planning Area. If the quotient resulting from this calculation exceeds a whole number by 0.50 or more, the number of dwelling units shall be increased to the next whole number.

3.11 MAINTENANCE

Table 3-5, *Maintenance Responsibilities*, summarizes the anticipated long-term maintenance responsibilities for the CENTRAL VILLAGE.

Table 3-5 MAINTENANCE RESPONSIBILITIES					
Facility	City of San Diego	San Ysidro School District	Master Maintenance Association	Otay Water District	Maintenance Assessment District (MAD)
Public Common Open Space (Including Common Area Slopes)			✓		
Private Common Open Space (Including Common Area Slopes)			✓		
Public Roadways (including standard public road improvements)	✓				
Public Roadways Landscape Elements (including landscaped parkways, roundabouts, lighting elements, and medians occurring within the Public ROW, and other non-standard public road improvements)			✓		✓



Table 3-5 MAINTENANCE RESPONSIBILITIES					
Facility	City of San Diego	San Ysidro School District	Master Maintenance Association	Otay Water District	Maintenance Assessment District (MAD)
Private Streets (including landscaped parkways and street lighting)			✓		
School Site		✓			
City-Owned Parks and Trails	✓				✓
Privately-Owned Parks and Trails			✓		
Pedestrian Paseos (outside the Public ROW)			✓		
Natural Open Space			✓		
Community Monuments and Hardscape Elements (within the Public ROW)					✓
Community Monuments and Hardscape Elements (outside the Public ROW)			✓		
Brush Management Zones			✓		
Potable Water Facilities				✓	
Recycled Water Facilities				✓	
Wastewater Treatment and Conveyance Facilities	✓				

Table 3-5 MAINTENANCE RESPONSIBILITIES					
<i>Facility</i>	<i>City of San Diego</i>	<i>San Ysidro School District</i>	<i>Master Maintenance Association</i>	<i>Otay Water District</i>	<i>Maintenance Assessment District (MAD)</i>
Storm Drain Facilities (within the Public ROW)	✓				
Storm Drain Facilities (within private streets)			✓		
Detention/ Water Quality Basins			✓		
Lighting (within the Public ROW)			✓		
Lighting (in common areas outside the Public ROW)			✓		



This page intentionally left blank.

4.0 GENERAL PLAN CONSISTENCY

4.1 GENERAL PLAN CONSISTENCY OVERVIEW

Pursuant to City of San Diego Land Development Code § 122.0107, specific plans do not have to rigidly conform to the general plan, but must demonstrate consistency with the goals and policies set forth in the local general plan to demonstrate that the specific plan and the general plan are in general harmony. This chapter demonstrates that the CENTRAL VILLAGE Specific Plan is consistent with, and results in the implementation of, applicable primary goals and policies of the City of San Diego’s General Plan and the Otay Mesa Community Plan.

4.1.1 SAN DIEGO GENERAL PLAN

Table 4-1 SAN DIEGO GENERAL PLAN CONSISTENCY	
SAN DIEGO GENERAL PLAN POLICY	SPECIFIC PLAN CONSISTENCY
LAND USE ELEMENT	
<p>City of Villages Strategy LU-A.2 Identify sites suitable for mixed-use village development that will complement the existing community fabric or help achieve desired community character, with input from recognized community planning groups and the general public.</p> <p>LU-A.9 Integrate public gathering spaces and civic uses into village design.</p>	<p>The CENTRAL VILLAGE Specific Plan incorporates a mixture of land uses including residential, commercial, civic (i.e. school), parks, and open space. The combination of these uses in a grid pattern street network establishes a development pattern that achieves the desired village character for the CENTRAL VILLAGE as set forth in the Otay Mesa Community Plan. The Otay Mesa Community Planning Group, property owners, and other members of the public were extensively engaged during the preparation of this Specific Plan, and the content of this Specific Plan was influenced by comments and input received during the outreach process. Accordingly, the CENTRAL VILLAGE Specific Plan is consistent with this policy.</p> <p>Specific Plan Figure 2.3-4 presents the non-vehicular mobility plan for the CENTRAL VILLAGE, while Section 2.5.1.3 provides design guidelines for outdoor common spaces and gathering areas within individual planning areas. A public school and park site are centrally located in the village. Also, as shown on Figure 2.3-4, the CENTRAL VILLAGE Specific Plan incorporates a number of pedestrian nodes that provide public gathering spaces throughout the village. Village Plaza is designed to serve as a “village core” reflecting a village plaza or town square character. Accordingly, the CENTRAL VILLAGE Specific Plan is consistent with this policy.</p>



Table 4-1 SAN DIEGO GENERAL PLAN CONSISTENCY	
SAN DIEGO GENERAL PLAN POLICY	SPECIFIC PLAN CONSISTENCY
<p>General Plan Land Use Categories</p> <p>LU-B.2 Identify a more refined street system than is included in the General Plan Land Use and Streets Map through the community plan update and amendment process.</p> <p>LU-B.3 Plan for and develop mixed-use projects where a site or sites are developed in an integrated, compatible, and comprehensively planned manner involving two or more land uses.</p>	<p>Specific Plan Figure 2.3-1 presents the vehicular mobility plan for the CENTRAL VILLAGE, which refines the Otay Mesa Community Plan Mobility Element to identify alignments for collector roadways within the village. Figure 2.3-1 also conceptually identifies the alignments for roadways internal to each planning area. Accordingly, the CENTRAL VILLAGE Specific Plan is consistent with this policy.</p> <p>The CENTRAL VILLAGE incorporates a mixture of land uses including residential, commercial, civic (i.e. school), parks, and open space. The CENTRAL VILLAGE Specific Plan sets forth a comprehensive mixed use plan for the 229.2-acre CENTRAL VILLAGE. Accordingly, the CENTRAL VILLAGE Specific Plan is consistent with this policy.</p>
<p>Balanced Communities and Equitable Development</p> <p>LU-H.1 Promote development of balanced communities that take into account communitywide involvement, participation, and needs.</p> <p>LU-H.6 Provide linkages among employment sites, housing, and villages via an integrated transit system and a well-defined pedestrian and bicycle network.</p>	<p>The CENTRAL VILLAGE Specific Plan comprehensively provides for a balanced community that serves the needs of its residents. The Specific Plan offers housing, a school, parks, mixed use areas that offer neighborhood-serving commercial enterprises, and trail linkages into adjacent open space areas. Industrial and business areas are located outside of the village, but in close proximity. The CENTRAL VILLAGE Specific Plan sets forth a design that is walkable and connected, which encourages residents and visitors to circulate in the community, socialize, and make a life with family and friends. The Otay Mesa Community Planning Group, property owners, and other members of the public were extensively engaged during the preparation of this Specific Plan, and this Specific Plan is the result of comments and input received during the outreach process. Accordingly, the CENTRAL VILLAGE Specific Plan is consistent with this policy.</p> <p>As shown in Figure 2.3-4 of the CENTRAL VILLAGE Specific Plan, <i>Alternative Transportation Plan</i>, the non-vehicular mobility network consists of potential transit stations along Airway Road, bicycle facilities, and pedestrian connections including pedestrian paseos, pedestrian nodes, and a trail located along the southern boundary of the village. Additionally, bike lanes are provided along Airway Road, Cactus Road, Heritage Road, village entries, and</p>

Table 4-1 SAN DIEGO GENERAL PLAN CONSISTENCY	
SAN DIEGO GENERAL PLAN POLICY	SPECIFIC PLAN CONSISTENCY
<p>LU-H.7 Provide a variety of different types of land uses within a community in order to offer opportunities for a diverse mix of uses and to help create a balance of land uses within a community.</p>	<p>green streets. Accordingly, the CENTRAL VILLAGE Specific Plan is consistent with this policy.</p> <p>The CENTRAL VILLAGE Specific Plan provides for a balance of land uses, including residential, commercial, civic (i.e. school), parks, and open space. Within residential areas, the Specific Plan also promotes variety among the types of residential product types. Residential development within the CENTRAL VILLAGE would range from 10 du/ac in the southern portion of the village to up to 44 du/ac in the high density multi-family and mixed use areas, which are largely clustered around Airway Road. As such, and in conformance with this policy, the CENTRAL VILLAGE accommodates a diverse and balanced mix of land uses.</p>
<p>Environmental Justice</p> <p>LU-I.14 As part of community plan updates or amendments that involve land use or intensity changes, evaluate public health risks associated with identified sources of hazardous substances and toxic air emissions (see also Conservation Element, Section F). Create adequate distance separation, based on documents such as those recommended by the California Air Resources Board and site specific analysis, between sensitive receptor land use designations and potential identified sources of hazardous substances such as freeways, industrial operations or areas such as warehouses, train depots, port facilities, etc.</p>	<p>The CENTRAL VILLAGE Specific Plan provides for the development of a mixed use village in a location and at an intensity called for by the Otay Mesa Community Plan. Regardless, to ensure that future residents of the CENTRAL VILLAGE are not exposed to any inequitable health risks associated with the property’s location and community design, the village’s location in context to surrounding land uses and potential health risk hazards was considered. Because the CENTRAL VILLAGE Specific Plan area is located near industrial land uses to the east and Cactus Road and south of Siempre Viva Road, a wide landscaped area is planned along Cactus Road and Specific Plan Chapter 2 includes design standards and policies that encourage building orientation toward the interior of the village in this area. In addition, because tailpipe emissions from diesel-fueled vehicles can pose health risks, the Specific Plan also requires residential setbacks and landscaped buffers at interfaces between residential uses and major roadways, including but not limited to Airway Road and SR-905. The CENTRAL VILLAGE Specific Plan is therefore consistent with Policy LU-I.14.</p>



Table 4-1 SAN DIEGO GENERAL PLAN CONSISTENCY	
SAN DIEGO GENERAL PLAN POLICY	SPECIFIC PLAN CONSISTENCY
MOBILITY ELEMENT	
Walkable Communities	
<p>ME-A.1 Design and operate sidewalks, streets, and intersections to emphasize pedestrian safety and comfort through a variety of street design and traffic management solutions.</p>	<p>The CENTRAL VILLAGE Specific Plan includes a grid-pattern system of streets, paseos, and trails that connect the CENTRAL VILLAGE’s planning areas to one another and to surrounding areas. The village design results in compact blocks that support walking and connectivity. In conformance with this policy, design standards and policies are provided in Chapter 2 that address pedestrian safety, including safety at street crossings.</p>
<p>ME-A.6 Work toward achieving a complete, functional, and interconnected pedestrian network.</p>	<p>As depicted on Specific Plan Figure 2.3-4, and in conformance with Policy ME-A.6, the CENTRAL VILLAGE provides an interconnected system of paseos, sidewalks, and trails that create a safe and pleasant pedestrian environment while providing connections between residential areas and commercial, recreation, school, and open space amenities within the community. The pedestrian system is designed to be complete, functional, and interconnected.</p>
<p>ME-A.8 Encourage a mix of uses in villages, commercial centers, transit corridors, employment centers and other areas as identified in community plans so that it is possible for a greater number of short trips to be made by walking.</p>	<p>The CENTRAL VILLAGE Specific Plan incorporates a mixture of land uses including residential, commercial, civic (i.e. school), parks, and open space, with commercial and higher density residential uses along Airway Road, which is planned as a future rapid transit corridor. As depicted on Specific Plan Figure 2.3-4, the CENTRAL VILLAGE provides an interconnected system of paseos, sidewalks, and trails that create a safe and pleasant pedestrian environment. The design of the CENTRAL VILLAGE limits block sizes and requires a grid-pattern network of internal streets that are walkable and connected. Accordingly, the CENTRAL VILLAGE Specific Plan is consistent with Policy ME-A.8.</p>
Transit First	
<p>ME-B.3 Design and locate transit stops/stations to provide convenient access to high activity/density areas, respect neighborhood and activity center character, implement community plan recommendations, enhance the users’ personal experience of each neighborhood/center, and contain comfortable walk and wait environments for customers</p>	<p>As shown in Figure 2.3-4, <i>Alternative Transportation Plan</i>, a future rapid transit route is accommodated along Airway Road to link commercial and high density residential uses within the CENTRAL VILLAGE with other key activity centers and employment nodes within Otay Mesa. By orienting higher density residential uses towards Airway Road instead of Cactus Road, the CENTRAL VILLAGE land use concept places residents and retail uses in close proximity to future transit uses. The village’s overall design and the location and number of pedestrian pathways and amenities ensures comfortable wait and walk environments for</p>

Table 4-1 SAN DIEGO GENERAL PLAN CONSISTENCY	
SAN DIEGO GENERAL PLAN POLICY	SPECIFIC PLAN CONSISTENCY
	those who will walk to the parks, gathering spaces, school, and commercial establishments in the village. As demonstrated in Table 4-2, <i>Otay Mesa Community Plan Consistency</i> , the CENTRAL VILLAGE Specific Plan is consistent with all applicable policies and requirements set forth in the Otay Mesa Community Plan relating to walkability and transit. The CENTRAL VILLAGE Specific Plan is consistent with Policy ME-B.3.
<p>Streets and Freeway System</p> <p>ME-C.6 Locate and design new streets and freeways and, to the extent practicable, improve existing facilities to: respect the natural environment, scenic character, and community character of the area traversed; and to meet safety standards.</p>	With exception of the future extension of Airway Road to the west and Heritage Road to the north, most roadways planned for the CENTRAL VILLAGE occur in areas that have been subject to past disturbance associated with crop production and goat husbandry. The construction of Future Airway Road to the west would not occur until a final grade and alignment study is conducted. Accordingly, The CENTRAL VILLAGE Specific Plan is consistent with Policy ME-C.6.
<p>Bicycling</p> <p>ME-F.2 Identify and implement a network of bikeways that are feasible, fundable, and serve bicyclists’ needs, especially for travel to employment centers, village centers, schools, commercial districts, transit stations, and institutions.</p>	As discussed in Section 2.3.2.2 of the CENTRAL VILLAGE Specific Plan, bike lanes are provided along Airway Road, Cactus Road, Future Heritage Road (north of Airway Road), village entries, and green streets. Bike facilities accommodated by the CENTRAL VILLAGE Specific Plan include Class 1 and Class 2 bike lanes, with both types of bike lanes accommodated along Airway Road. These bike facilities connect village residents to employment centers, the village center, the school, commercial uses, and transit stops. Accordingly, the CENTRAL VILLAGE Specific Plan is consistent with Policy ME-F.2.
<p>Parking Management</p> <p>ME-G.5 Implement parking strategies that are designed to help reduce the number and length of automobile trips. Reduced automobile trips would lessen traffic and air quality impacts, including greenhouse gas emissions.</p>	The CENTRAL VILLAGE Specific Plan is designed to promote walking, biking, and transit use to reduce the number and length of automobile trips. As shown on Specific Plan Figures 2.3-2 and 2.3-3, with exception of Airway Road, Cactus Road, and Future Heritage Road (north of Airway Road), all roadways within the village, including internal roadways, feature parallel parking on both sides of the street. Furthermore, Specific Plan Section 2.5.2 and Section 2.5.3 incorporate a number of guidelines related to sustainability that serve to reduce the CENTRAL VILLAGE’s greenhouse gas emissions. The CENTRAL VILLAGE Specific Plan is therefore consistent with General Plan Policy ME-G.5.
<p>Regional Coordination and Financing</p> <p>ME-K.4 Determine necessary transportation improvements to serve new</p>	The CENTRAL VILLAGE Specific Plan implements the major transportation



Table 4-1 SAN DIEGO GENERAL PLAN CONSISTENCY	
SAN DIEGO GENERAL PLAN POLICY	SPECIFIC PLAN CONSISTENCY
<p>development at the community plan level, and where necessary, at the project level.</p>	<p>improvements called for in the area by the Otay Mesa Community Plan. A transportation facilities trigger analysis was prepared concurrent with the adoption of this Specific Plan, and identifies site access and other required improvements to on- and off-site roadway facilities. The analysis identified transportation improvements warranted upon buildout of the Specific Plan area and identified the triggering project trip generation for roadway facilities needed to serve the various phases of the Project. In addition, all future individual developments within the CENTRAL VILLAGE Specific Plan would be required to prepare a site specific transportation impact study to assess impacts. The results of the analysis showed the CENTRAL VILLAGE Specific Plan would generate 20% less traffic than was assumed by the Otay Mesa Community Plan Update.</p>
URBAN DESIGN ELEMENT	
<p>General Urban Design UD-A.1 Preserve and protect natural landforms and features.</p> <p>a) Protect the integrity of community plan designated open spaces.</p> <p>b) Continue to implement the Multiple Species Conservation Program (MSCP) to conserve San Diego’s natural environment and create a linked open space system. Preserve and enhance remaining naturally occurring features such as wetlands, riparian zones, canyons, and ridge lines.</p> <p>UD-A.2 Use open space and landscape to define and link communities.</p> <p>b) Preserve and encourage preservation of physical connectivity and access to open space.</p>	<p>As shown on Specific Plan Figure 2.2-1, the land use plan for the CENTRAL VILLAGE designates open space areas in the same places and configurations as called for by the Otay Mesa Community Plan. With exception of small encroachments into Community Plan-designated open space to accommodate the required construction of Airway Road in a feasible alignment that conforms to engineering requirements, the CENTRAL VILLAGE Specific Plan protects and avoids impacts to MHPA areas. This Specific Plan also incorporates MSCP criteria for fuel management, landscaping, and physical barriers adjacent to the MHPA to protect the open space areas from indirect effects associated with adjacent development. Accordingly, the CENTRAL VILLAGE Specific Plan is consistent with Policy UD-A.1.</p> <p>As described in Section 2.4.2 of the CENTRAL VILLAGE Specific Plan, the CENTRAL VILLAGE accommodates approximately 15.9 acres of open space in a manner that is consistent with the Otay Mesa Community Plan Land Use Plan. Disturbances to open space are minimized along the interface between open space areas and proposed residential development. The CENTRAL VILLAGE Specific Plan Land Use Map is consistent with and implements the Otay Mesa Community Plan Land Use Map, which was designed, in part, to encourage preservation of physical connectivity and access to open space. Additionally,</p>

Table 4-1 SAN DIEGO GENERAL PLAN CONSISTENCY	
SAN DIEGO GENERAL PLAN POLICY	SPECIFIC PLAN CONSISTENCY
<p>UD-A.6 Create street frontages with architectural and landscape interest to provide visual appeal to the streetscape and enhance the pedestrian experience.</p>	<p>Specific Plan Figure 2.3-4 depicts the trail connections and access points accommodated by the CENTRAL VILLAGE Specific Plan. Accordingly, the CENTRAL VILLAGE Specific Plan is consistent with Policy UD-A.1.</p>
<p>UD-A.8 Landscape materials and design should enhance structures, create and define public and private spaces, and provide shade, aesthetic appeal, and environmental benefits.</p>	<p>As discussed extensively in Specific Plan Section 2.5.2 and in conformance with Policy UD-A.6, street frontages are designed to provide visual appeal to the streetscape and enhance the pedestrian experience.</p>
<p>UD-A.9 Incorporate existing and proposed transit stops or stations into project design.</p>	<p>In accordance with Policy UD-A.8, and as discussed in Specific Plan Section 2.3.2.3 and Section 2.5.1.4, the CENTRAL VILLAGE Specific Plan promotes the use of specialty paving, landscaping, shade structures, seating areas, and other enhancements to provide an improved pedestrian experience along the pedestrian circulation network. Additionally, the majority of tree species listed in the Specific Plan’s plant palette were selected for their ability to provide ample shade over pedestrian walkways, streetscapes, and gathering spaces. Landscape materials identified in the CENTRAL VILLAGE plant palette (refer to Table 2.5-2) are composed primarily of drought-tolerant plant species, thereby reducing water demand for irrigation purposes. Based on the foregoing discussion, the Specific Plan is consistent with Policy UD-A.8.</p>
<p>UD-A.10 Design or retrofit streets to improve walkability, bicycling, and transit integration; to strengthen connectivity; and to enhance community identity. Streets are an important aspect of Urban Design as referenced in the Mobility Element.</p>	<p>As shown on CENTRAL VILLAGE Specific Plan Figure 2.3-4, <i>Alternative Transportation Plan</i>, bus stops are accommodated in three locations along Airway Road through the CENTRAL VILLAGE. Additional transit stops may be identified in the future along internal collector roadways as the Metropolitan Transit System (MTS) expands service in the area. Accordingly, the CENTRAL VILLAGE Specific Plan is consistent with Policy UD-A.9.</p>
	<p>As shown on Figure 2.3-4 of the CENTRAL VILLAGE Specific Plan, <i>Alternative Transportation Plan</i>, the mobility system consists of transit stops along Airway Road, bicycle facilities, and pedestrian connections including pedestrian paseos, pedestrian nodes, and a trail located along the southern boundary of the village. Additionally, bike lanes are provided along Airway Road, Cactus Road, Heritage Road (north of Airway Road), village entries, and green streets. For improved walkability, a pedestrian paseo network is one of the connective</p>



Table 4-1 SAN DIEGO GENERAL PLAN CONSISTENCY	
SAN DIEGO GENERAL PLAN POLICY	SPECIFIC PLAN CONSISTENCY
<p>UD-A.13 Provide lighting from a variety of sources at appropriate intensities and qualities for safety.</p>	<p>fabrics of the CENTRAL VILLAGE, connecting pedestrian nodes positioned where there are higher pedestrian densities. As such, the CENTRAL VILLAGE Specific Plan is consistent with Policy UD-A.10.</p> <p>In conformance with Policy UD-A.10, Section 2.5.3.9 of the CENTRAL VILLAGE Specific Plan contains design guidelines to establish a well-designed lighting program. A coordinated illumination and light fixture design also strengthens the village’s character. Lighting levels with ample ambient coverage in consideration of public safety are provided for in all areas of the village, except for open space areas. Accordingly, the CENTRAL VILLAGE Specific Plan is consistent with Policy UD-A.13.</p>
<p>Distinctive Neighborhoods and Residential Design UD-B.8 Provide useable open space for play, recreation, and social or cultural activities in multifamily as well as single family projects.</p>	<p>In conformance with Policy UD-B.8, the CENTRAL VILLAGE Specific Plan designates four park facilities that range in size from 3.1 net acres to 6.0 net acres in size. Each park is designed to serve and complement its surrounding context. Vista Park and Trails Park (Planning Areas 15 and 18, respectively) are oriented towards the open space areas to the south and southwest. Village Park provides a local neighborhood facility to serve the medium and high density residential uses within Planning Areas 10 through 13. Village Central Park provides an active space between residential and commercial uses. The remainder of the CENTRAL VILLAGE’s population-based park requirements will be met by the adjacent Grand Park, which is planned by the Otay Mesa Community Plan as a regional facility complete with formal ball fields. Accordingly, the CENTRAL VILLAGE Specific Plan is consistent with Policy UD-A.10.</p>
<p>Mixed Use Villages and Commercial Areas UD-C.1 In villages and transit corridors identified in community plans, provide a mix of uses that create vibrant, active places in villages.</p>	<p>The CENTRAL VILLAGE Specific Plan is designed as a master-planned, compact, pedestrian-oriented village anchored by two activity nodes. The design promotes vibrancy and outdoor activity. Streets are activated by orienting development along the primary roadways and incorporating streetscapes that accommodate multiple modes of transportation, including walking, biking, and transit. The two activity nodes are connected by Central Main Street, which ties the village together from east to west and provides access to additional parks, residential and mixed use planning areas, and a school. Within the village is a mixture of residential, commercial, civic (i.e., school), recreational,</p>

Table 4-1 SAN DIEGO GENERAL PLAN CONSISTENCY	
SAN DIEGO GENERAL PLAN POLICY	SPECIFIC PLAN CONSISTENCY
<p>UD-C.3 Develop and apply building design guidelines and regulations that create diversity rather than homogeneity, and improve the quality of infill development.</p> <p>UD-C.4 Create pedestrian-friendly village centers.</p> <p>UD-C.5 Design village centers as civic focal points for public gatherings with public spaces.</p>	<p>and open space land uses, with higher intensity uses oriented around Airway Road, which accommodates bus rapid transit facilities. The CENTRAL VILLAGE Specific Plan supports the bus rapid transit route by identifying three bus station locations within the CENTRAL VILLAGE, located near the activity centers of the community. Accordingly, the CENTRAL VILLAGE Specific Plan is consistent with Policy UD-C.1.</p> <p>Section 2.5.2 the CENTRAL VILLAGE Specific Plan sets forth a series of building design guidelines that provide a defined palette of design elements, such as recessed windows, pop-outs, bay windows, decorative trim, and other treatments to add visual interest to the façade and avoid homogeneity. Accordingly, the CENTRAL VILLAGE Specific Plan is consistent with Policy UD-C.3.</p> <p>As demonstrated throughout the CENTRAL VILLAGE Specific Plan, the village is pedestrian-oriented and its design minimizes conflicts between motorists and pedestrians. The Specific Plan provides for an attractive mixed use community setting that encourages social interaction while meeting the day-to-day needs of residents and visitors through the inclusion of parks, outdoor common areas and gathering spaces, and neighborhood-serving commercial uses. Accordingly, the CENTRAL VILLAGE Specific Plan is consistent with Policy UD-C.4.</p> <p>CENTRAL VILLAGE Specific Plan Figure 2.3-4 depicts the interconnected system of paseos, sidewalks, and trails accommodated within the village. A safe and pleasant pedestrian environment is created, while providing for a series of pedestrian nodes to encourage social interaction. In addition, positive frontage is encouraged around streets, the school, and parks, with tucked away parking that is internal to the block wherever possible. These concepts encourage residents and visitors to use the streetscapes, outdoor common areas, pedestrian nodes, parks, and other gathering spaces to interact and socialize. The Specific Plan also promotes the design and arrangement of buildings to create well-defined common areas. For example, by clustering buildings around courtyards, greenways, paseos, and plazas to encourage their use as defined outdoor gathering spaces. As such, the Specific Plan is consistent with this policy.</p>



Table 4-1 SAN DIEGO GENERAL PLAN CONSISTENCY	
SAN DIEGO GENERAL PLAN POLICY	SPECIFIC PLAN CONSISTENCY
<p>UD-C.6 Design project circulation systems for walkability.</p>	<p>The CENTRAL VILLAGE Specific Plan is designed as a walkable community that features a number of paseos, trails, and other enhanced amenities for pedestrian users. CENTRAL VILLAGE Specific Plan Figure 2.3-4 depicts the interconnected system of paseos, sidewalks, and trails accommodated within the village. Accordingly, the CENTRAL VILLAGE Specific Plan is consistent with Policy UD-C.6.</p>
ECONOMIC PROSPERITY ELEMENT	
<p>Commercial Land Use</p> <p>EP-B.3 Concentrate commercial development in Neighborhood, Community, and Urban Villages, and in Transit Corridors.</p> <p>EP-B.9 Design new community commercial centers with consideration for: traffic patterns; compatibility with surrounding land uses; site planning that reinforces pedestrian movement to and through the site; superior architecture and landscape design; and sustainable design.</p>	<p>In conformance with Policy EP-B.3, the CENTRAL VILLAGE Specific Plan, which is identified as a Neighborhood and Community Village by the Otay Mesa Community Plan, accommodates commercial development clustered along Airway Road, a planned transit corridor.</p> <p>The CENTRAL VILLAGE Specific Plan features a mixed use design with a grid-pattern street system that responds to and carefully considers traffic patterns and surrounding land uses. The CENTRAL VILLAGE’s vehicular and non-vehicular mobility plans reinforce pedestrian movement along streets and in a well-developed paseo network. Commercial enterprises in the mixed use planning areas will be walkable from residential areas and welcoming to the pedestrian. Architecture and landscape design, as discussed in Specific Plan Sections 2.5.2 and 2.5.3; and sustainable design elements, through adherence to the sustainable design criteria contained within these sections, will make the commercial uses inviting and compatible with their context. Accordingly, the CENTRAL VILLAGE Specific Plan is consistent with Policy EP-B.9.</p>
PUBLIC FACILITIES, SERVICES, AND SAFETY ELEMENT	
<p>Wastewater</p> <p>PF-F.6 Coordinate land use planning and wastewater infrastructure planning to provide for future development and maintain adequate service level.</p>	<p>During the development of the CENTRAL VILLAGE Specific Plan, consideration was given to wastewater infrastructure planning, as reflected in the design of CENTRAL VILLAGE’s sewer plan (refer to Section 2.6.1 and Figure 2.6-2). As such, the Specific Plan is consistent with Policy PF-F.6.</p>
RECREATION ELEMENT	
<p>Park and Recreation Guidelines</p> <p>RE-A.3 Take advantage of recreational opportunities presented by the natural</p>	<p>In accordance with Policy RE-A.3, and as depicted on Figure 2.4-1, <i>Parks and</i></p>

Table 4-1 SAN DIEGO GENERAL PLAN CONSISTENCY	
SAN DIEGO GENERAL PLAN POLICY	SPECIFIC PLAN CONSISTENCY
<p>environment in particular beach/ocean access and open space.</p> <p>RE-A.8 Provide population-based parks at a minimum ratio of 2.8 useable acres per 1,000 residents.</p>	<p><i>Open Space Plan</i>, the CENTRAL VILLAGE includes two park facilities, Vista Park (Planning Area 15) and Trails Park (Planning Area 18), both of which are oriented towards the open space located south and west of the village area. Additional view corridors are available along the trail system within Planning Area 21.</p> <p>The CENTRAL VILLAGE accommodates up to 4,485 homes, which, if fully built out in accordance with the Specific Plan Land Use Plan depicted on Figure 2.2-1, results in a future population of approximately 15,473 people, at 3.45 persons per household. Based on the required ratio of 2.8 useable park acres per 1,000 residents, the CENTRAL VILLAGE generates a maximum demand for 43.3 useable acres of parkland. As shown on Figure 2.2-1, the CENTRAL VILLAGE accommodates 16.1 net usable acres of parkland. The remainder of the CENTRAL VILLAGE population-based parkland requirement (27.2 acres) is accommodated in the Grand Park. As planned by the Otay Mesa Community Plan, the Grand Park will meet this portion of the population-based park requirements for the CENTRAL VILLAGE. Accordingly, the CENTRAL VILLAGE Specific Plan is consistent with Policy RE-A.8.</p>
<p>Accessibility</p> <p>RE-D.1 Provide new and upgraded park and recreation facilities that employ barrier-free design principles that make them accessible to San Diegans regardless of age or physical ability, giving priority to economically disadvantaged communities.</p> <p>RE-D.2 Provide barrier-free trails and outdoor experiences and opportunities for persons with disabilities where feasible.</p> <p>RE-D.6 Provide safe and convenient linkages to, and within, park and recreation facilities and open space areas.</p>	<p>Four parks are provided in the CENTRAL VILLAGE, all of which are designed to meet the needs of the entire community, regardless of age or physical ability. The CENTRAL VILLAGE is not located in an economically disadvantaged community, as Otay Mesa is only partially developed and contains very little residential development. The CENTRAL VILLAGE Specific Plan is consistent with Policy RE-D.1.</p> <p>The design of two of the park facilities accommodated within the CENTRAL VILLAGE, Village Park and Village Plaza, incorporate hardscape elements that are accessible to persons with disabilities. Accordingly, the CENTRAL VILLAGE Specific Plan is consistent with Policy RE-D.2.</p> <p>In conformance with Policy RE-D.6, and as depicted on Figure 2.3-4, all four of the parks within the CENTRAL VILLAGE are connected by a series of pedestrian paseos, bike routes, and sidewalks. The two parks adjacent to open space also</p>



Table 4-1 SAN DIEGO GENERAL PLAN CONSISTENCY	
SAN DIEGO GENERAL PLAN POLICY	SPECIFIC PLAN CONSISTENCY
	are connected by trails. Accordingly, the CENTRAL VILLAGE Specific Plan is consistent with Policy RE-D.6.
<p>Open Space Lands and Resource-Based Parks RE-F.7 Create or enhance open space multi-use trails to accommodate, where appropriate, pedestrians/hikers, bicyclists, and equestrians.</p>	In accordance with General Plan Policy RE-F.7, trails in the village will accommodate hikers and bicyclists
CONSERVATION ELEMENT	
<p>Climate Change and Sustainable Development CE-A.2 Reduce the City's carbon footprint. Develop and adopt new or amended regulations, programs, and incentives as appropriate to implement the goals and policies set forth in the General Plan to:</p> <ul style="list-style-type: none"> • Create sustainable and efficient land use patterns to reduce vehicular trips and preserve open space. • Reduce the Urban Heat island effect through sustainable design and building practices, as well as planting trees 	Sections 2.5.2 and 2.5.3 of the CENTRAL VILLAGE Specific Plan incorporate sustainability guidelines that apply to all development within the CENTRAL VILLAGE, and serve to reduce the carbon footprint of the CENTRAL VILLAGE. The CENTRAL VILLAGE Land Use Plan, as depicted on Figure 2.2-1, creates an efficient land use pattern by clustering higher density and commercial uses along Airway Road, which is a planned transit corridor. Additionally, the CENTRAL VILLAGE preserves as open space all areas designated for open space by the Otay Mesa Community Plan. The streetscapes for the CENTRAL VILLAGE, provided in Section 2.5.3.2 of the Specific Plan, provides for single and dual rows of trees along all streets to reduce the urban heat island effect. Landscape setbacks, which occur along the frontage with Cactus Road and the northern portions of Planning Areas 9, 11, and 12, also incorporate landscaping to help reduce the heat island effect. Other measures included in Section 2.5.3.2 include reducing the amount of site paving; providing paving material that remains cool and allows water to filter through the soil; increasing landscaped areas; and providing shade throughout the site in order to reduce ambient temperatures and solar heat gain on constructed surfaces. Based on the foregoing analysis, the CENTRAL VILLAGE Specific Plan is consistent with Policy CE-A.2.
<p>Open Space and Landform Preservation CE-B.6 Provide an appropriate defensible space between open space and urban areas through the management of brush, the- use of transitional landscaping, and the design of structures.</p>	Section 2.5.3.5 of the CENTRAL VILLAGE Specific Plan provides requirements for the management of brush between residential uses on-site and natural open space located both on- and off-site. The standards provided are consistent with the requirements set forth in San Diego Land Development Code Section 142.0412. Accordingly, the CENTRAL VILLAGE Specific Plan is consistent with Policy CE-B.6.

Table 4-1 SAN DIEGO GENERAL PLAN CONSISTENCY	
SAN DIEGO GENERAL PLAN POLICY	SPECIFIC PLAN CONSISTENCY
<p>Water Resources Management</p> <p>CE-D.1 Implement a balanced, water conservation strategy as an effective way to manage demand by: reducing dependence on imported water supplies; maximizing the efficiency of existing urban water and agricultural supplies through conservation measures/programs; and developing alternative, reliable sources to sustain present and future water needs.</p>	<p>Specific Plan Sections 2.5.2 and 2.5.3 incorporate sustainable design principles that include measures that reduce water demand, including the use of drought-tolerant plants. Section 2.5.3.8 mandates compliance with the City’s Landscaping Water Conservation Ordinance, which promotes overall water conservation through the use of low water use plumbing fixtures, highly efficient irrigation system design standards, and the use of reclaimed water as a non-potable resource if made available. Additional policies also are included in Section 2.5.3.8 to further reduce the CENTRAL VILLAGE’s demand for water resources. As such, the CENTRAL VILLAGE Specific Plan is consistent with Policy CE-D.1.</p>
<p>Urban Runoff Management Goals</p> <p>CE-E.2 Apply water quality protection measures to land development projects early in the process-during project design, permitting, construction, and operations-in order to minimize the quantity of runoff generated on-site, the disruption of natural water flows and the contamination of storm water runoff.</p> <p>g) Apply land use, site development, and zoning regulations that limit impacts on, and protect the natural integrity of topography, drainage systems, and water bodies.</p>	<p>A preliminary drainage and water quality report was prepared in conjunction with the CENTRAL VILLAGE Specific Plan, which sets forth conceptual water quality and LID strategies. The drainage system is designed to utilize the property’s natural drainage courses to the extent feasible. As discussed in Specific Plan Section 2.6.2, best management practices are required to filter pollutants from storm water before the water is discharged from the village. The exact siting of these facilities will be determined during future site planning efforts. The hydrology and water quality report informed development of the Specific Plan Land Use Plan (Figure 2.2-1). Accordingly, the CENTRAL VILLAGE Specific Plan is consistent with Policy CE-E.2.</p>
<p>Biological Diversity</p> <p>CE-G.3 Implement the conservation goals/policies of the City’s MSCP Subarea Plan, such as providing connectivity between habitats and limiting recreational access and use to appropriate areas.</p>	<p>The CENTRAL VILLAGE Specific Plan Land Use Map is consistent with and implements the Otay Mesa Community Plan Land Use Map and the MSCP Subarea Plan. In accordance with Policy CE-G.3, the CENTRAL VILLAGE Specific Plan provides for open space in the same places called for by the Otay Mesa Community Plan, which ensures connectivity between habitats. This Specific Plan also incorporates MSCP criteria for fuel management, landscaping, and physical barriers adjacent to the MHPA to protect the open space areas from indirect effects associated with adjacent development. A trail system is provided in the open space in the southern portion of the village and signage is required that will direct people to stay on the trails and keep away from sensitive habitat.</p>



Table 4-1 SAN DIEGO GENERAL PLAN CONSISTENCY	
SAN DIEGO GENERAL PLAN POLICY	SPECIFIC PLAN CONSISTENCY
NOISE ELEMENT	
<p>Motor Vehicle Traffic Noise NE-B.7 Promote the use of berms, landscaping, setbacks, and architectural design where appropriate and effective, rather than conventional wall barriers to enhance aesthetics.</p>	<p>In compliance with Policy NE B-7, Sections 2.5.1.6 and 2.5.3.4 of the CENTRAL VILLAGE Specific Plan require that noise attenuation be addressed through the use of berms, planting, setbacks, and architectural design rather than with conventional wall barriers for developments next to industrial uses, highways or other potential noise-generating uses.</p>
<p>Commercial and Mixed-Use Activity Noise NE-E.1 Encourage the design and construction of commercial and mixed-use structures with noise attenuation methods to minimize excessive noise to residential and other noise sensitive land uses.</p>	<p>In conformance with OMCP Policy NE-E.1, landscaping screening and/or walls are provided throughout CENTRAL VILLAGE to reduce noise impacts and protect the privacy of residential units along high-traffic streets and intense uses. In addition, insulating materials and landscaping is encouraged on commercial sites to attenuate the noises generated within and outside the Specific Plan area.</p>

4.1.2 OTAY MESA COMMUNITY PLAN

Table 4-2 OTAY MESA COMMUNITY PLAN CONSISTENCY	
OTAY MESA COMMUNITY PLAN POLICY	SPECIFIC PLAN CONSISTENCY
LAND USE ELEMENT	
Specific Plan Uses	
<p>LU-2.1-2 Achieve sustainable and efficient land use patterns with comprehensive neighborhood and community village development through Specific Plans that:</p> <p>a) Respect the natural topography and sensitive habitat areas with growth patterns that balance development with preservation of natural resources.</p> <p>b) Provide a land use map that illustrates the detailed land use designations, including any lands set aside for resource conservation, consistent with the MSCP Subarea Plan and any future Vernal Pool Habitat Conservation Plan. The specific plan land use map will refine the Otay Mesa Community Plan Land Use Map (Figure 2-1) as part of the specific plan approval process.</p> <p>c) Illustrate the complete circulation system that, where possible, follows a grid pattern, and indicate how the system will relate to the overall Otay Mesa circulation system.</p> <p>d) Strive for block sizes along local and collector streets to have a maximum</p>	<p>As discussed in Sections 2.5.1.6 and 2.5.3.4 of the CENTRAL VILLAGE Specific Plan, natural areas are preserved and disturbances are minimized along the interface between open space areas and proposed development. The interface between open space and residential uses include walls or fencing that precludes residents from accessing open space areas. In addition, where disturbance occurs within open space areas to build the village, native species will be used to revegetate disturbed lands and restore them to a natural condition. The plant palette is consistent with the requirements of the MSCP Sub-Area Plan. Additionally, sensitive zones within CENTRAL VILLAGE, such as fuel modification zones, are given special care.</p> <p>A Land Use Map is provided in the CENTRAL VILLAGE Specific Plan (refer to Figure 2.2-1). The CENTRAL VILLAGE Specific Plan Land Use Map is consistent with and implements the Otay Mesa Community Plan Land Use Map and the MSCP Subarea Plan. A Vernal Pool Habitat Conservation Plan is currently being developed in coordination with the wildlife Resource Agencies. There are no existing vernal pool resources located within the CENTRAL VILLAGE Specific Plan Area. Disturbances to MHPA areas are addressed in a manner consistent with the MSCP Subarea Plan by identifying areas for preservation within the MHPA to offset impacts to MHPA areas.</p> <p>A Circulation/Mobility Plan is provided in Section 2.3 of the CENTRAL VILLAGE Specific Plan (refer to Figure 2.3-1) that illustrates the grid pattern proposed for the CENTRAL VILLAGE. The planned mobility network provides for maximum connectivity within the CENTRAL VILLAGE. The grid-pattern system of streets connects the CENTRAL VILLAGE to surrounding areas, resulting in compact blocks that support walkability and enhanced connectivity throughout the CENTRAL VILLAGE.</p> <p>Section 2.5.1.4 of the CENTRAL VILLAGE Specific Plan restricts the perimeter of</p>



Table 4-2 OTAY MESA COMMUNITY PLAN CONSISTENCY	
OTAY MESA COMMUNITY PLAN POLICY	SPECIFIC PLAN CONSISTENCY
<p>perimeter of 1,800 feet.</p> <p>e) Illustrate a separate system of pedestrian and bicycle facilities and pathways linking the activity centers with the residential areas, public facilities, and open space systems.</p> <p>f) Distribute parks comprehensively throughout the village area.</p> <p>g) Identify specific locations for schools, parks, pedestrian pathways and trails. <ol style="list-style-type: none"> 1. Site schools and parks adjacent to each other to create activity centers within neighborhoods. 2. Include pathways and trails that connect public facilities with each other and to residential areas. </p> <p>j) Provide development at densities that support transit as an integral component of village areas and corridors.</p>	<p>blocks within the CENTRAL VILLAGE to a maximum of 1,800 feet, consistent with this policy.</p> <p>As shown in Figure 2.3-4 of the CENTRAL VILLAGE Specific Plan, <i>Alternative Transportation Plan</i>, the mobility system consists of potential transit stations along Airway Road, bicycle facilities, and pedestrian connections including pedestrian paseos, pedestrian nodes, and a trail located along the southern boundary of the village. Additionally, bike lanes are provided along Airway Road, Cactus Road, Heritage Road, village entries, and green streets. For improved walkability, a grid of paseos serve as the connective fabric of the CENTRAL VILLAGE. Pedestrian nodes occur where there are higher pedestrian densities.</p> <p>As shown in Section 2.4 of the CENTRAL VILLAGE Specific Plan and in Figure 2.4-1, the CENTRAL VILLAGE includes four parks: Village Park, Village Central Park, Vista Park, and Trails Park. These parks are linked together through a system of paseos, pedestrian nodes, and trails, and are distributed comprehensively throughout the CENTRAL VILLAGE.</p> <p>A combined school/park is accommodated within Planning Area 14 (refer to Figure 2.2-1). The school is planned as a K-8 school on approximately 13 acres, with 5 acres of recreation fields and facilities that may be used jointly by the school and village residents, subject to approval by the San Ysidro School District. Additionally, Specific Plan Section 2.3.2 provides for a comprehensive non-vehicular mobility system that connects residents and visitors to homes, shopping, parks, trails, and the school (refer to Figure 2.3-3, <i>Alternative Transportation Plan</i>).</p> <p>The CENTRAL VILLAGE Specific Plan accommodates a variety of housing types ranging in density from 10 du/ac to 44 du/ac. These densities support transit along Airway Road as well potential future transit routes along interior collector roads.</p>

Table 4-2 OTAY MESA COMMUNITY PLAN CONSISTENCY	
OTAY MESA COMMUNITY PLAN POLICY	SPECIFIC PLAN CONSISTENCY
<p>k) Require a mixed-use residential/commercial component to be included within village core areas, with neighborhood-serving commercial uses such as food markets, restaurants, and other small retail shops. Encourage an anchor grocery store within each village area.</p>	<p>The CENTRAL VILLAGE Specific Plan designates seven planning areas within the community for mixed uses (i.e., residential and commercial). Development standards for commercial land uses within these planning areas allow for a variety of neighborhood-serving commercial land uses, including food markets, restaurants, small retail shops, and small grocery stores.</p>
<p>l) Identify centrally located mixed-use core areas within each village area adjacent to key roadways and transit stops. Require a minimum of 15 du/ac for core areas designated Neighborhood Village and 30 du/ac for core areas designated Community Village.</p>	<p>The CENTRAL VILLAGE Specific Plan accommodates mixed uses (commercial and residential) in seven planning areas, all of which are located adjacent to Airway Road where transit stops are planned. Areas planned for higher density residential uses are clustered along Airway Road instead of along Cactus Road, as called for by the Otay Mesa Community Plan. By orienting higher-density residential uses towards Airway Road instead of Cactus Road, the CENTRAL VILLAGE land use concept places residents and retail uses in close proximity to future transit uses. Additionally, although four planning areas in the southern portion of the Specific Plan area would allow for development at densities as low as 10 du/ac, these planning areas are constrained by topography and/or would be utilized for drainage and water quality purposes, thereby reducing the potential maximum number of dwelling units that would be feasible. Thus, while the gross density of these planning areas would be below 15 du/ac, the clustered residential uses in the unconstrained portions of these planning areas would yield residential product types that are similar in character to dwelling units constructed at 15 du/ac. Furthermore, these planning areas have a Target Density of 15-29 du/ac.</p>
<p>o) Include a detailed design plan for the mixed-use village core areas that identifies retail, convenience uses, and public spaces.</p>	<p>The CENTRAL VILLAGE Specific Plan land use concept and development standards provide for retail uses intermixed with high density residential uses, and accommodate ample public spaces both within the four planned park sites and throughout the community along the paseo and trail network.</p>
<p>p) Provide sufficient community serving commercial development within village core areas and along transit corridors that support the residents, workforce, and visitors as these areas develop</p>	<p>The CENTRAL VILLAGE Specific Plan accommodates up to 139,700 s.f. of commercial uses (including commercial retail), all of which is located along Airway Road where mass transit facilities are planned.</p>



Table 4-2 OTAY MESA COMMUNITY PLAN CONSISTENCY	
OTAY MESA COMMUNITY PLAN POLICY	SPECIFIC PLAN CONSISTENCY
<p>q) Provide refined architecture, urban design, and streetscape guidelines consistent with the policies in the Otay Mesa Community Plan and the General Plan.</p> <p>r) Include guidelines and illustrations for height, bulk, and scale of buildings and their relation to each other.</p> <p>s) Provide a street tree plan that utilizes species within the Otay Mesa Street Tree Plan.</p>	<p>Chapter 2 of the CENTRAL VILLAGE Specific Plan incorporates guidelines addressing architecture, urban design, and streetscapes, which were crafted to be consistent with the Otay Mesa Community Plan.</p> <p>Section 2.5.2 of the CENTRAL VILLAGE Specific Plan includes guidelines and illustrations addressing the height, bulk, and scale of buildings and their relation to each other.</p> <p>Section 2.5.3.1 of the CENTRAL VILLAGE Specific Plan includes a plant palette for landscape treatments along all roadways within the CENTRAL VILLAGE. Per the requirements of the Otay Mesa Community Plan, tree species specified for the streetscapes were selected from the City of San Diego’s Otay Mesa Street Tree Plan.</p> <p>Based on the discussion presented above, the CENTRAL VILLAGE Specific Plan is consistent with OMCP Policy LU-2.1-2.</p>
<p>Buffers LU-2.2-4 Provide adequate buffer uses/distance separation for residential proposals within a quarter mile of industrial uses with hazardous or toxic substances.</p>	<p>The CENTRAL VILLAGE accommodates landscaped buffers at interfaces between residential uses, major roadways, off-site industrial uses, and SR-905. Landscaped buffers and setbacks are provided along the frontage of Cactus Road to separate uses from heavy truck traffic and industrial uses east of Cactus Road. Standards are incorporated into Specific Plan Chapter 2 to require appropriate landscape buffers between Planning Areas 11-12 and SR-905. Lastly, the CENTRAL VILLAGE Specific Plan provides a landscaped buffer along the northern edge of Planning Area 9 in order to protect residents from potential future light industrial development north of Planning Area 9. Accordingly, the CENTRAL VILLAGE Specific Plan is consistent with OMCP Policy LU-2.2-4.</p>

Table 4-2 OTAY MESA COMMUNITY PLAN CONSISTENCY	
OTAY MESA COMMUNITY PLAN POLICY	SPECIFIC PLAN CONSISTENCY
<p>Open Space and Parks</p> <p>LU-2.6 Maintain the existing Open Space, and collaborate with the wildlife agencies, environmental groups and the public to ensure adequate conservation for sensitive biological resources and consistency with the City’s MSCP Subarea Plan.</p>	<p>The CENTRAL VILLAGE Land Use Plan is designed to provide consistency with the Otay Mesa Community Plan while also respecting the various sensitive biological resources that occur throughout Otay Mesa surrounding the village. The CENTRAL VILLAGE accommodates approximately 15.9 acres of open space in a manner that is consistent with the Otay Mesa Community Plan Land Use Plan. Additionally, and with exception of Airway Road – a General Plan and Community Plan Mobility Element facility – impacts to MHPA areas would be avoided. The CENTRAL VILLAGE Specific Plan also incorporates standards for interfaces between on-site development and adjacent MHPA areas. Accordingly, the CENTRAL VILLAGE is consistent with or otherwise would not conflict with OMCP Policy LU-2.6.</p>
MOBILITY ELEMENT	
<p>Walkability</p> <p>M-3.1 Provide a sidewalk and trail system with connections to villages, activity centers, and open spaces.</p> <p>a) Prioritize connections that link activity centers and create safe routes to schools, transit, and village areas.</p> <p>d) Improve the quality of the walking experience through streetscape, shading, and separation from travel lanes.</p> <p>f) Provide multi-use (equestrian, biking, pedestrian use) trails except where maintenance, resource protection or safety concerns warrant limiting use of one or more of the above user groups.</p> <p>M- 3.1-5 Implement the Community’s Street Tree Master Plan to contribute to more walkable, tree-lined streets, using identified drought tolerant species. (Urban Design Element Section 4.8)</p>	<p>As depicted on Figure 2.3-3 and discussed in Section 2.3.2.3, the CENTRAL VILLAGE provides an interconnected system of paseos, sidewalks, and trails that create a safe and pleasant pedestrian environment while providing connections between residential areas and commercial, recreation, school, and open space amenities within the village. The CENTRAL VILLAGE also incorporates specialty paving, landscaping, shade structures, seating areas, and other enhancements to provide an enhanced pedestrian experience along the pedestrian circulation network. Paseos and trails also accommodate bicycle and pedestrian use, with equestrian uses accommodated within the trail network planned in the on- and off-site open space areas, in a manner that is consistent with the MSCP Sub-Area Plan requirements.</p> <p>As discussed in Section 2.5.3.2, in order to enhance the pedestrian experience, tree species specified for the community’s streetscapes have been selected from the City of San Diego’s <i>Otay Mesa Street Tree Plan</i> and are provided along the village’s backbone roadway network. Compliance with the Otay Mesa Street Tree Plan will ensure drought-resistant plants are incorporated into the CENTRAL VILLAGE streetscapes to provide for an aesthetically enhanced pedestrian experience, in conformance with OMCP Policy M-3.1-5.</p>



Table 4-2 OTAY MESA COMMUNITY PLAN CONSISTENCY	
OTAY MESA COMMUNITY PLAN POLICY	SPECIFIC PLAN CONSISTENCY
<p>Transit M-3.3-14 Emphasize transit orientation in village development plans including but not limited to those identified on the Land Use Map, Figure 2-1.</p>	<p>In conformance with OMCP Policy M-3.3-14, Figure 2.3-4 of the CENTRAL VILLAGE Specific Plan depicts a future rapid transit route along Airway Road to link CENTRAL VILLAGE mixed use planning areas and high-density zones with other key activity centers and employment nodes within Otay Mesa.</p>
<p>Streets and Freeways M-3.3-1 Provide an interconnected network of public streets and internal project circulation systems as an organizing framework for development.</p> <p>c) Minimize the use of cul-de-sacs, and require pedestrian and bicycle connections to collector streets for any proposed cul-de-sacs.</p> <p>M-3.3-2 Avoid street design configurations that rely on free-flow turn lanes that conflict with bicycle and pedestrian movements.</p> <p>M-3.3-4 Provide adequate sidewalk width and separation from travel lanes for major pedestrian routes connecting activity centers.</p> <p>M-3.3-5 Plant drought tolerant trees adjacent to the curb in grates or parkways, as referenced in the Street Tree Plan.</p> <p>M-3.3-10 Utilize a grid or modified grid street system within village areas.</p>	<p>As depicted on Figure 2.3-1, the CENTRAL VILLAGE provides connectivity throughout each planning area by a system of interconnected streets and pedestrian paths generally oriented in a grid pattern that minimizes potential conflicts between pedestrians, bicyclists, and motorists. The Specific Plan avoids barriers to access by prohibiting cul-de-sacs; dead end streets; disconnected bike and pedestrian paths; wide streets that lack pedestrian support; and long blocks that discourage walking. Accordingly, the CENTRAL VILLAGE Specific Plan is consistent with OMCP Policies M-3.3-1, M-3.3-2, and M-3.3-4.</p> <p>In conformance with the City of San Diego’s <i>Otay Mesa Street Tree Plan</i>, and as discussed in Section 2.5.3.2, the Specific Plan incorporates drought resistant trees along streetscapes and parkways. All plant and tree species accommodated in the CENTRAL VILLAGE are fully consistent with the <i>Otay Mesa Street Tree Plan</i>, which was designed to maximize the use of drought-tolerant species. Accordingly, the CENTRAL VILLAGE Specific Plan is consistent with OMCP Policy M-3.3-5.</p> <p>As shown on Figure 2.3-1, the CENTRAL VILLAGE accommodates a grid system of streets and pedestrian pathways to create compact blocks that encourage walking and bike riding. Accordingly, the CENTRAL VILLAGE Specific Plan is consistent with OMCP Policy LU-3.3-10.</p>

Table 4-2 OTAY MESA COMMUNITY PLAN CONSISTENCY	
OTAY MESA COMMUNITY PLAN POLICY	SPECIFIC PLAN CONSISTENCY
<p>Bicycles</p> <p>M-3.4-1 Refine and implement the BMP in the Otay Mesa Community Plan area.</p> <p>a) Develop bicycle facilities that implement internal connectivity to activity areas within the community and links to regional bicycle network.</p> <p>e) Bikeways within the village areas should connect to trail heads with access to the canyon system trails and pathways.</p> <p>f) Provide secure bicycle parking, especially near transit and in the community village areas.</p>	<p>In accordance with the Otay Mesa Community Plan’s Bike Master Plan, Class 1 and/or Class 2 bicycle facilities are accommodated along Airway Road (Classes 1 and 2), Cactus Road (Class 2), Heritage Road (Class 2, both north and south of Airway Road), Central Main Street (Class 1), Park Way (Class 1), Village Way (Class 2 north of Central Main Street), and Continental Road (Class 2).</p> <p>In accordance with the Otay Mesa Community Plan Bike Master Plan, there are four linkages that connect the CENTRAL VILLAGE bike trails to the surrounding trailheads. These linkage allow bicyclists easy accessibility to canyon system trails and pathways.</p> <p>As discussed in Policy 2.5-21 of the Specific Plan, adequate, accessible, and conveniently located bicycle parking and storage areas are provided for throughout the CENTRAL VILLAGE.</p> <p>Based on the foregoing discussion, the CENTRAL VILLAGE Specific Plan is consistent with OMCP Policy M-3.4-1.</p>
URBAN DESIGN ELEMENT	
<p>Distinct Districts</p> <p>UD-4.1-4 Require development intensities that create active commercial centers, support transit, and encourage lively streetscapes.</p> <p>b) Provide pedestrian amenities and activities to activate streets.</p> <p>UD-4.1-8 Minimize exposure of residential uses from noise, traffic and air quality impacts associated with SR-905 and truck routes through: the orientation of buildings and site planning, the design of buildings, landscape treatments, and distance separation</p>	<p>The CENTRAL VILLAGE accommodates high density residential and commercial land uses concentrated along Airway Road, a planned transit corridor. As discussed in CENTRAL VILLAGE Specific Plan Section 2.3.2.3, a series of pedestrian nodes accommodated along the village’s extensive paseo network provide places for residents and visitors to sit, relax, and observe. Pedestrian nodes activate the pedestrian mobility network and add vibrancy to the CENTRAL VILLAGE. As such, the CENTRAL VILLAGE Specific Plan is consistent with OMCP Policy UD-4.1-4.</p> <p>The CENTRAL VILLAGE accommodates landscaped buffers at interfaces between residential uses, major roadways, off-site industrial uses, and SR-905. Specifically, landscaped buffers and setbacks are provided along the frontage of Cactus Road to separate uses from heavy truck traffic and industrial uses east of Cactus Road. Standards also are incorporated into Specific Plan</p>



Table 4-2 OTAY MESA COMMUNITY PLAN CONSISTENCY	
OTAY MESA COMMUNITY PLAN POLICY	SPECIFIC PLAN CONSISTENCY
<p>UD-4.1-9 Provide site specific use recommendations, which may include commercial, industrial, parking, and other non-residential uses, for development that will be adjacent to freeways and truck routes. Analyze air quality impacts for land uses along the freeways and truck routes.</p>	<p>Chapter 2 to require appropriate landscape buffers between Planning Areas 11-12 and SR-905 to minimize the adverse aesthetic, air quality, and noise effects from vehicular traffic along SR-905. Lastly, the CENTRAL VILLAGE Specific Plan provides a landscaped buffer along the northern edge of Planning Area 9 to protect future on-site residents from potential future light industrial development to the north. Accordingly, the CENTRAL VILLAGE Specific Plan is consistent with Policy UD-4.1-8.</p> <p>The CENTRAL VILLAGE abuts the SR-905 freeway, Cactus Road, and Airway Road, all of which are utilized to some degree for truck movement, although neither Cactus Road nor Airway Road are designated truck routes by the Otay Mesa Community Plan. Standards are incorporated into Specific Plan Chapter 2 to require appropriate landscape buffers between Planning Areas 11-12 and SR-905 to minimize the adverse aesthetic, air quality, and noise effects from vehicular traffic along SR-905. Accordingly, the CENTRAL VILLAGE Specific Plan is consistent with OMCP Policy UD-4.1-9.</p>
<p>Streetscapes UD-4.2-1 Implement pedestrian-oriented design principles at the project-level to activate the street and promote walkability.</p> <p>UD-4.2-2 Incorporate connectivity and walkability in the design of the street network.</p> <p>a) Apply traffic-calming techniques that address vehicular/truck and pedestrian movements where the truck routes are adjacent to village and park uses.</p> <p>g) Activate vibrant village cores using street furniture, sidewalk cafes, and public spaces.</p>	<p>The streetscapes within the CENTRAL VILLAGE Specific Plan (refer to Figure 2.3-4, <i>Alternative Transportation Plan</i>) focus on size, scale, landscaping, and traffic calming features to encourage pedestrian activity. The CENTRAL VILLAGE provides site furnishings such as benches, bicycle racks, bollards, kiosks, streetscape signage, and trash receptacles along streets that contain major pedestrian thoroughfares to create a lively and comfortable environment. As such, the CENTRAL VILLAGE Specific Plan complies with Policy UD-4.2-1.</p> <p>The grid-pattern system of streets depicted on Figure 2.3-1 results in compact blocks that support walkability and enhanced connectivity throughout the CENTRAL VILLAGE. There are no truck routes located within the CENTRAL VILLAGE, although buffers are incorporated to protect residential uses from truck traffic along Cactus Road, Airway Road, and SR-905, as well as buffering residential areas from the existing light industrial operations located north of Planning Area 9. The CENTRAL VILLAGE provides site furnishings such as benches, bicycle racks, bollards, kiosks, streetscape signage, and trash receptacles along streets that contain major pedestrian thoroughfares to create a lively and</p>

Table 4-2 OTAY MESA COMMUNITY PLAN CONSISTENCY	
OTAY MESA COMMUNITY PLAN POLICY	SPECIFIC PLAN CONSISTENCY
	comfortable environment. Based on the foregoing discussion, the CENTRAL VILLAGE is consistent with OMCP Policy UD-4.2-2.
<p><u>Building Character</u></p> <p>UD-4.3-2 Provide public space, parks, and scenic overlooks at the end of streets and adjacent to open space areas to take full advantage of scenic opportunities.</p> <p>UD-4.3-7 Create visual and physical linkages within villages, neighborhoods, and project site areas through a unified landscape theme.</p>	<p>In accordance with OMCP Policy UD-4.3-2, Section 2.4.2 of the CENTRAL VILLAGE Specific Plan designates Open Space in the locations called for by the Otay Mesa Community Plan. Scenic overlooks, staging areas, picnic areas, greenways and trails are provided for in Vista Park and Trails Park. (See also Figure 2.3-3, <i>Alternative Transportation Plan</i>)</p> <p>Figure 2.6-34 presents the locations of markers and monuments that are planned to provide a unified theme for the village. Additionally, Figures 2.3-1 and 2.3-4 depict the vehicular and non-vehicular circulation plans, respectively, which together provide the structure for physical linkages to and between the residential, commercial, park, civic (i.e., school), and open space uses within the CENTRAL VILLAGE. Accordingly, the CENTRAL VILLAGE Specific Plan is consistent with OMCP Policy UD-4.3-7.</p>
<p><u>Public Spaces</u></p> <p>UD-4.7-2 Activate public spaces with visual interest and community amenities.</p>	<p>As discussed in Section 2.5.2.1, streets within the CENTRAL VILLAGE are activated by orienting development along the primary roadways and incorporating streetscapes that accommodate multiple modes of transportation, including walking, biking, and transit. In addition, positive frontage is encouraged around streets, the school, and parks, with tucked away parking that is internal to the block wherever possible. Additionally, and as discussed in Specific Plan Section 2.3.2.3, pedestrian nodes provide places for residents and visitors to sit, relax, and observe; each node displays cohesive design elements, which help to tie the community together and reinforce its visual identity. Accordingly, the CENTRAL VILLAGE Specific Plan is consistent with Policy UD-4.7-2.</p>



Table 4-2 OTAY MESA COMMUNITY PLAN CONSISTENCY	
OTAY MESA COMMUNITY PLAN POLICY	SPECIFIC PLAN CONSISTENCY
<p><u>Street Trees</u> UD-4.8-1 Select street trees identified in Appendix B along all streets and roadways in the Street Tree Plan to create a unified theme for the street, provide effective canopy, and improve community aesthetics.</p>	<p>In accordance with OMCP Policy UD-4.8-1, Section 2.5.3.2 of the CENTRAL VILLAGE Specific Plan requires all street trees within CENTRAL VILLAGE to be selected from the Otay Mesa Community Plan Street Tree List (Otay Mesa Community Plan Appendix B, <i>Street Tree Plan</i>). By adhering to the Otay Mesa Street Tree Plan, street trees within the CENTRAL VILLAGE provide a unified theme, effective canopy, and improved community aesthetics. Accordingly, the CENTRAL VILLAGE Specific Plan is consistent with OMCP Policy UD-4.8-1.</p>
<p><u>Sustainability</u> UD-4.9-1 Design new development to have climate sensitive, energy efficient, and environmentally oriented site design.</p>	<p>Section 2.2.2.1 of the CENTRAL VILLAGE Specific Plan requires that buildings be oriented to take advantage of natural daylight and prevailing breezes for increased cross ventilation and reduce the need for mechanical air conditioning. Shade is also provided throughout the village to reduce ambient temperatures and solar heat gain on constructed surfaces. Incorporating climate sensitive, energy efficient, and environmentally oriented site design is a consideration throughout the CENTRAL VILLAGE Specific Plan and demonstrates consistency with OMCP Policy UD-4.9-1.</p>
<p><u>View Corridors</u> UD-4.12-3 Provide public views and vantage points to the surrounding canyon systems within the Southwest and Central Villages. Consider perimeter roads with no development on the canyon side to preserve public access.</p>	<p>In accordance with OMCP Policy UD-4.12-3 and as described in Section 2.4 of the CENTRAL VILLAGE Specific Plan, three primary view corridors are accommodated within the village: within the southern portion of Vista Park and Trails Park in Planning Areas 15 and 18, and along the trail segments that traverse Planning Area 21. As depicted on Figure 2.4-1, the trail network accommodated within the CENTRAL VILLAGE provides public access to all three view corridor locations. Accordingly, the CENTRAL VILLAGE Specific Plan is consistent with OMCP Policy UD-4.12-3.</p>
ECONOMIC PROSPERITY ELEMENT	
<p><u>Commercial Areas</u> EP-5.2-1 Require that each village include neighborhood-serving commercial uses such as food markets, restaurants, and other small retail shops. Encourage an anchor grocery store within each village area.</p>	<p>In accordance with OMCP Policy EP-5.2-1, the CENTRAL VILLAGE Specific Plan contains seven planning areas designated for mixed use, which allows commercial land uses such as food markets, restaurants, and other small retail shops.</p>

Table 4-2 OTAY MESA COMMUNITY PLAN CONSISTENCY	
OTAY MESA COMMUNITY PLAN POLICY	SPECIFIC PLAN CONSISTENCY
PUBLIC FACILITIES, SERVICES & SAFETY ELEMENT	
<p>Wastewater PFSS-6.2-1 Continue to coordinate with the development community to provide reasonable and adequate facilities in conjunction with future development.</p>	<p>Specific Plan Section 2.6 identifies the infrastructure improvements needed to serve development within the CENTRAL VILLAGE; necessary circulation, water, sewer, and drainage infrastructure improvements are required to be in place at the time of occupancy of future residential or commercial structures. Accordingly, the CENTRAL VILLAGE Specific Plan is consistent with OMCP Policy PFSS-6.2-1</p>
<p>Storm Water Infrastructure PFSS-6.3-4 Implement the City's Master Storm Water System Maintenance Plan to ensure storm water conveyance facilities remain free of invasive plants, sediments or other debris that can reduce their capacity.</p>	<p>As required by Section 2.5.3.1 of the CENTRAL VILLAGE Specific Plan, invasive plant species are prohibited throughout the CENTRAL VILLAGE. Additionally, and as discussed in Section 2.6.2, there are five options for addressing water quality concerns within the Specific Plan area, all of which require best management practices (BMPs) that preclude excessive sedimentation of downstream storm water conveyance facilities while preventing other debris (such as trash) that can reduce their capacity. Accordingly, the CENTRAL VILLAGE Specific Plan is consistent with OMCP Policy PFSS-6.3-4.</p>
<p>Water Infrastructure PFSS-6.4-1 Provide a water supply that adequately serves the future growth of Otay Mesa.</p> <p>PFSS-6.4-2 Encourage development that implements water conservation and pollution prevention measures that exceed minimum requirements.</p>	<p>Otay Water District (OWD) determined that an updated Water Supply Assessment (WSA) would not be required for the approval of the CENTRAL VILLAGE Specific Plan. Although the Specific Plan would result in a slight increase in the OWD service area, this slight increase was found by OWD to be in general conformance with the May 2013 water supply assessment for the OMCP Area. The OWD also indicated that future implementing developments within the CENTRAL VILLAGE area may be required to obtain updated WSAs at the individual project level of analysis.</p> <p>As discussed in Sections 2.5.3.8 of the CENTRAL VILLAGE Specific Plan, development within CENTRAL VILLAGE promotes overall water conservation through the use of low water use plumbing fixtures, highly efficient irrigation system design standards, drought-tolerant species in the CENTRAL VILLAGE landscape plant palette, and the use of reclaimed water as a non-potable resource (when available). Additionally, and as discussed in Section 2.6.2, there are five options for addressing water quality concerns within the Specific</p>



Table 4-2 OTAY MESA COMMUNITY PLAN CONSISTENCY	
OTAY MESA COMMUNITY PLAN POLICY	SPECIFIC PLAN CONSISTENCY
	Plan area, all of which require best management practices (BMPs) that substantially reduce the amount of pollutants in runoff. As such, the CENTRAL VILLAGE Specific Plan is consistent with OMCP Policy PFSS-6.4-2.
RECREATION ELEMENT	
<p>Park and Recreation Guidelines</p> <p>R-7.1-1 Use specific plans to determine the specific quantity, locations and acreages of population-based parks, based on General Plan standards, and to provide recommendations about specific park uses and design intent.</p> <p>R-7.1-5 Provide a diverse mix of neighborhood parks, mini parks, pocket parks and plazas.</p> <p>R-7.1-6 Locate neighborhood parks adjacent to schools and open space areas when possible. Consider additional joint use agreements to expand recreational opportunities beyond those planned to meet General Plan population-based park acreage requirements.</p>	<p>In accordance with OMCP Policy R-7.1-1, the CENTRAL VILLAGE Specific Plan specifies the quantity, location, and acreages of all population-based parks located within the CENTRAL VILLAGE (refer to Figure 2.2-1), and includes recommendations about design intent (refer to Specific Plan Section 2.4.1). The CENTRAL VILLAGE accommodates up to 4,485 homes, which, if fully built out in accordance with the Specific Plan Land Use Plan depicted on Figure 2.2-1, results in a future population of approximately 15,473 people at 3.45 persons per household. Based on the required ratio of 2.8 useable acres per 1,000 residents, the CENTRAL VILLAGE generates a demand for 43.3 useable acres of parkland. As shown on Figure 2.2-1, the CENTRAL VILLAGE accommodates 16.1 net usable acres of parkland. The remainder of the CENTRAL VILLAGE population-based parkland requirement (27.2 acres) is accommodated in the Grand Park. As planned by the Otay Mesa Community Plan, the Grand Park is intended to meet a portion of the population-based park requirements for the CENTRAL VILLAGE.</p> <p>As shown on Figure 2.4-1, the CENTRAL VILLAGE includes four parks: Village Park, Village Central Park, Vista Park, and Trails Park. As discussed in Section 2.4.1 of the CENTRAL VILLAGE Specific Plan, the character of each park is different and unique in a manner that is responsive to its location near and orientation to mixed use, residential, and open space land uses; thus, the CENTRAL VILLAGE Specific Plan provides a diverse mix of parks, in conformance with OMCP Policy R-7.1-5.</p> <p>A combined school/park may be accommodated within Planning Area 14 (refer to Figure 2.2-1), subject to approval by the San Ysidro School District. The school/park site consists of approximately 13.1 net acres, of which approximately 5 acres consist of play areas, multi-purpose turf areas and courts, sports fields, and parking, and are jointly used by the school and village</p>

Table 4-2 OTAY MESA COMMUNITY PLAN CONSISTENCY	
OTAY MESA COMMUNITY PLAN POLICY	SPECIFIC PLAN CONSISTENCY
<p>R-7.1-8 Locate new park and recreation areas so that they are readily accessible and can be reached through safe and convenient approaches.</p> <p>R-7.1-11 Provide improved public access from recreation facilities, canyons, open space, and community villages using sidewalks, pathways, and trails.</p>	<p>for recreation activities. It should be noted that, pursuant to the Otay Mesa Community Plan Recreation Element, any park uses that may be accommodated in the future within the school/park site would not count towards the CENTRAL VILLAGE population-based park requirement. In addition to the school/park, Vista Park (Planning Area 15) and Trails Park (Planning Area 18) are neighborhood parks comprising 9.5 net acres (combined), and are located adjacent to natural open space associated with Spring Canyon. Accordingly, the CENTRAL VILLAGE Specific Plan is consistent with OMCP Policy R-7.1-6.</p> <p>Specific Plan Section 2.3.2 provides for a comprehensive non-vehicular mobility system that connects residents and visitors to homes, retail, parks, trails, and the school (refer to Figure 2.3-3, <i>Alternative Transportation Plan</i>). Accordingly, the CENTRAL VILLAGE is consistent with OMCP Policy R-7.1-8.</p> <p>As discussed in Specific Plan Section 2.3.2.3, the CENTRAL VILLAGE includes a system of paseos, pedestrian nodes, trails, and curb-separated sidewalks that provide public access between residential areas, parks, open space, canyons, and the commercial uses clustered along Airway Road. Accordingly, the CENTRAL VILLAGE is consistent with OMCP Policy R-7.1-11.</p>
<p>Open Space Lands and Resource Based Parks</p> <p>R-7.2-2 Minimize activities that require alterations to the natural open space.</p>	<p>Open space areas within the Specific Plan area are located in the same positions and configurations as called for by the Otay Mesa Community Plan. Approximately one acre on the western edge of Planning Area 19 is designated for open space; but this appears to be the result of a mapping area error because the land is disturbed and is used for agricultural land uses under existing conditions. Therefore, the open space designation does not apply, and no violation would occur.</p> <p>Other than trails that may traverse the open space areas within the CENTRAL VILLAGE and the off-site open space areas, the CENTRAL VILLAGE Specific Plan envisions no major alterations to the natural open space. Trails within the CENTRAL VILLAGE comply with the MSCP Sub-Area Plan requirements for trails within the MHPA. Accordingly, the CENTRAL VILLAGE Specific Plan is consistent</p>



Table 4-2 OTAY MESA COMMUNITY PLAN CONSISTENCY	
OTAY MESA COMMUNITY PLAN POLICY	SPECIFIC PLAN CONSISTENCY
	with OMCP Policy R-7.2-2.
CONSERVATION ELEMENT	
Habitat and Sensitive Lands Protection	
<p>C-8.1-1 Implement the Environmentally Sensitive Lands Regulations related to biological resources and steep hillsides for all new development.</p> <p>C-8.1-3 Plan development to minimize grading and relate to the topography and natural features of Otay Mesa.</p>	<p>The CENTRAL VILLAGE Specific Plan, in accordance with OMCP Policy C-8.1-1, ensures that all future development will implement the Environmentally Sensitive Lands Regulations, and respect the sub-area MSCP, in relation to biological resources and steep hillsides.</p> <p>The CENTRAL VILLAGE Specific Plan, in accordance with OMCP Policy C-8.1-3, preserves topography and natural features in the open space areas called for by the Otay Mesa Community Plan within the village.</p>
Climate Change and Sustainable Development	
<p>C-8.2-4 Reduce project level greenhouse gas emissions to acceptable levels through project design, application of site-specific mitigation measures, or adherence to standardized measures outlined in the City’s adopted Citywide Climate Action Plan.</p>	<p>The CENTRAL VILLAGE Specific Plan Sections 2.5.2 and 2.5.3 incorporate sustainable design guidelines that are intended, in part, to reduce the level of greenhouse gas emissions generated by development within the CENTRAL VILLAGE. Additionally, because the village design promotes walking, biking, and transit use, greenhouse gas emissions associated with vehicle tailpipe emissions would be measurably reduced. Accordingly, the CENTRAL VILLAGE Specific Plan is consistent with OMCP Policy C-8.2-4.</p>
Water	
<p>C-8.3-3 Require new development and redeveloping properties to use water conserving plant material and techniques to comply with the landscape water budget of the Municipal Code.</p>	<p>CENTRAL VILLAGE Specific Plan Section 2.5.3.8 incorporates a series of design guidelines that reduce water usage associated with landscaping, including measures to ensure compliance with the Water Conservation provisions set forth in San Diego Land Development Code § 142.0413. Additionally, and as shown in Table 2.5-2, the CENTRAL VILLAGE incorporates a variety of plant species that are drought tolerant. Accordingly, the CENTRAL VILLAGE Specific Plan is consistent with OMCP Policy C-8.3-3.</p>
Air Quality	
<p>C-8.7-2 Implement a pattern of land uses that can be efficiently served by a multi-modal transportation system that directly and indirectly minimizes air pollutants.</p>	<p>The CENTRAL VILLAGE Specific Plan is designed to concentrate higher-intensity residential and commercial uses along Airway Road, which is planned as a bus rapid transit corridor. The CENTRAL VILLAGE also includes a series of pedestrian and bike paths and trails that link residential areas to the commercial uses, parks, and transit routes along Airway Road, thereby further reducing</p>

Table 4-2 OTAY MESA COMMUNITY PLAN CONSISTENCY	
OTAY MESA COMMUNITY PLAN POLICY	SPECIFIC PLAN CONSISTENCY
	vehicular trips and attendant air pollutants. Accordingly, the CENTRAL VILLAGE Specific Plan is consistent with OMCP Policy C-8.7-2.
NOISE ELEMENT	
<p>Commercial and Industrial Activity</p> <p>N-9.2-1 Encourage site design techniques for mixed-use village areas that help to reduce the effect of noise from commercial and industrial uses.</p> <p>N-9.2-3 Include noise reduction features in the design of any project with noise sources that may affect adjacent and/or sensitive uses.</p>	<p>The CENTRAL VILLAGE provides for landscaped buffers, setbacks, and walls where necessary to attenuate noise associated with nearby industrial uses. Wide parkways occur along both Airway Road and Cactus Road to help attenuate noise from traffic along these roadways. In cases where it is necessary, and as discussed in Section 2.5.3.4, sound attenuation walls and/or landscaped are provided to achieve the required noise level standards. Accordingly, the CENTRAL VILLAGE Specific Plan is consistent with OMCP Policies N-9.2-1 and N-9.2-3.</p>
HISTORIC PRESERVATION ELEMENT	
<p>Identification and Preservation of Historical Resources</p> <p>HP-10.1-1 Require archaeological surveys and consultation with interested Native Americans as part of future development within Otay Mesa.</p> <p>HP-10.1-2 Consider eligible for listing on the City’s Historical Resources Register any significant archaeological or Native American cultural sites that may be identified as part of future development within Otay Mesa.</p>	<p>The 229.2-acre CENTRAL VILLAGE property (prior to development pursuant to this Specific Plan) is predominantly used for agricultural crop production (i.e., oat production). The southeastern portion contains several scattered buildings and structures associated with on-going crop production and goat husbandry. No known historic resources or resources that would be eligible for listing on the City’s Historical Resources Register occur within the CENTRAL VILLAGE area. As a requirement of the Otay Mesa Community Plan Update Environmental Impact Report (EIR) archaeological surveys and consultation with interested Native American tribes are required before ground-disturbing development activities associated with the Specific Plan area can occur. If important resources are uncovered, they are required to be evaluated for listing in the City’s Historical Resources Register. These required actions demonstrate consistency with OMCP Policy HP-10.1-1 and HP-10.1-2.</p>



This page intentionally left blank.