

## REVISED DRAFT

This Document is a draft pending final approval. Please contact a CCDC Planner @ (619) 235-2200 to discuss your project.

# Centre City Streetscape Manual



Prepared for:  
Centre City Development Corporation  
401 B Street, Suite 400  
San Diego, CA 92101-4298  
(619) 235-2200  
[www.ccdc.com](http://www.ccdc.com)

Prepared by:  
Estrada Land Planning  
Nasland Engineering

Updated by:  
CCDC

# REVISED DRAFT

This Document is a draft pending final approval. Please contact a CCDC Planner at (619) 235-2200 to discuss your project.

## *Table of Contents*

<b>I. INTRODUCTION</b>	<b>1</b>
<b>II. ADMINISTRATION</b>	<b>1</b>
<b>III. DESIGN INTENT</b>	<b>2</b>
<b>IV. DESIGN STANDARDS</b>	<b>4</b>
Sidewalk Width	4
Standard Street Corner	4
Street Corner Pop-Outs	4
Curbs, Gutters & Pedestrian Ramps	6
Clear Zones	6
Street Lights	7
Street Light Conformance	7
Street Trees	7
Stoop and Planter Encroachment	10
Underground Parking or Basements	10
Utility Covers, Mechanical Equipment & Transformer Vaults	10
Sidewalk Under Drains	10
Litter Receptacles	11
Newspaper Vending Machines	11
Sidewalk Cafés	11
<b>V. SPECIFIC RECOMMENDATIONS</b>	<b>12</b>
<b>STREET TREES</b>	<b>12</b>
Permits for Removal and Addition of Street Trees	12
Tree Grates	12
Root Control Barriers	13
Structural Soil	13
Street Tree Irrigation	13
Street Tree Classifications	14
District Street Trees	14
Special Street Trees	15
Gateway Street Trees	18
Ceremonial Street Trees	18
Sidewalk Paving Classifications	21
District Sidewalk Paving	21
Special Sidewalk Paving	21
Gateway Sidewalk Paving	24
Ceremonial Sidewalk Paving	24
Street Lighting Classifications	27

# REVISED DRAFT

This Document is a draft pending final approval. Please contact a CCDC Planner at (619) 235-2200 to discuss your project.

District Street Lights	27
Special Street Lights	27
Gateway Street Lights	27
Ceremonial Street Lights	27
<b>VI. TECHNICAL APPENDIX</b>	<b>A-1</b>
<b>SIDEWALK PAVING</b>	<b>A-1</b>
Asian Pacific Paving	A-1
Ballpark District Paving	A-2
Broadway Paving	A-3
CCDC Standard Paving	A-4
CCDC Brick Paving	A-5
Children's Park Paving	A-5
Gaslamp Quarter Paving	A-6
Horton Plaza	A-7
Island Avenue Paving	A-8
Little Italy Paving	A-8
Marina Paving	A-9
Market Street Paving	A-9
Pacific Highway Paving	A-10
Park-to-Bay Paving	A-11
<b>TREE GRATES</b>	<b>A-13</b>
CCDC Standard Tree Gate	A-13
CCDC Standard Tree Gate	A-14
Special and Gateway Tree Gate	A-15
Special and Gateway Tree Gate	A-16
Ceremonial Tree Gate and Little Italy Tree Gate	A-17
Asian Pacific Tree Gate	A-18
Children's Park Tree Gate	A-19
Park to Bay Tree Gate	A-20
<b>STREET LIGHTING</b>	<b>A-21</b>
Standard Light	A-21
Enhanced Standard Light	A-24
Little Italy Enhanced Standard Light	A-26
Gateway Light	A-27
Gaslamp Light	A-30
Tear-Drop Fixture	A-32
Asian Pacific Fixture	A-34
Type 15 Cobra Head Fixture	A-37
<b>MISCELLANEOUS</b>	<b>A-38</b>
CCDC Standard Litter Receptacle	A-38
Gaslamp Litter Receptacle	A-39
Little Italy Litter Receptacle	A-39
Park to Bay Litter Receptacle	A-39
Anti-Graffiti Coating	A-39
Root Control Barrier	A-40

# REVISED DRAFT

This Document is a draft pending final approval. Please contact a CCDC Planner at (619) 235-2200 to discuss your project.

<b>VII. CONSTRUCTION DETAIL APPENDIX</b>	<b>B-1</b>
<b>Paving Details</b>	<b>B-1</b>
Typical Street Section	B-1
Brick Paving (Non-Vehicular)	B-2
Brick Paving (Vehicular)	B-3
Brick Paving at Pedestrian Ramp	B-4
Brick Paving at Street Light	B-4
Brick Paving at Fire Hydrant	B-6
Brick Paving at Parking Meter/Street Signs	B-7
Concrete Paving with Expansion Joint	B-8
Interlocking Pavers	B-9
<b>Planting</b>	<b>B-10</b>
Tree Well Detail	B-10
Root Barrier Installation	B-11
Tree Well Installation	B-12
Tree Well Framework	B-13
Tree Grate Attachment in Brick Paving	B-14
Tree Grate Attachment in Concrete	B-15
<b>IRRIGATION DETAILS</b>	<b>B-16</b>
Reduced Pressure Backflow Prevention Assembly	B-16
Globe Valve (Located in Paving Areas)	B-17
Automatic Control Valve (Located in Paving Areas)	B-18
Bubbler Heads At Tree Well	B-19
Quick Coupler Valve with Globe Valve	B-20
<b>VIII. SPECIFICATION APPENDIX</b>	<b>C-1</b>
Structural Soil	C-1
<b>IX. STREET TREE APPENDIX</b>	<b>D-1</b>
Cupaniopsis anacardioides–Carrotwood	D-2
Cupressus sempervirens–Italian Cypress	D-2
Fraxinus oxycarpa–Raywood Ash	D-2
Fraxinus uhdei–Evergreen Ash	D-2
Jacaranda mimosifolia–Jacaranda	D-3
Koelreuteria bipinnata–Chinese Flame Tree	D-3
Magnolia grandiflora–Southern Magnolia	D-3
Phoenix canariensis–Canary Island Date Palm	D-3
Pistacia chinensis–Chinese Pistache	D-4
Platanus acerifolia–London Plane Tree	D-4
Podocarpus gracilior–Fern Pine	D-4
Pyrus calleryana ‘Bradford–Bradford Pear	D-4



# REVISED DRAFT

This Document is a draft pending final approval. Please contact a CCDC Planner at (619) 235-2200 to discuss your project.

Pyrus calleryana ‘Chanticleer’–Chanticleer Pear _____	D-5
<i>Sapium sebiferum</i> –Chinese Tallow Tree _____	D-5
Syagrus romanzoffianum–Queen Palm _____	D-5
Tipuana tipu–Tipu Tree _____	D-5
Tristania conferta–Brisbane Box _____	D-6
<i>Ulmus parvifolia</i> –Chinese Evergreen Elm _____	D-6
Washingtonia robusta–Mexican Fan _____	D-6
Palm _____	D-6

## List of Figures

Figure 1: Neighborhood Districts.....	3
Figure 2: Standard Street Corner with Parking .....	4
Figure 3: Sidewalk Pop-Outs .....	5
Figure 4: Clear Zone .....	6
Figure 5: Typical Street Light Layout .....	8
Figure 6: Typical Tree Layout .....	9
Figure 7: Typical Receptacle Layout.....	11
Figure 8: District Street Trees .....	16
Figure 9: Special Street Trees .....	17
Figure 10: Gateway Street Trees.....	19
Figure 11: Ceremonial Street Trees.....	20
Figure 12: District Sidewalk Paving.....	22
Figure 13: Special Sidewalk Paving.....	23
Figure 14: Gateway Sidewalk Paving .....	25
Figure 15: Ceremonial Sidewalk Paving .....	26
Figure 16: District Street Lights.....	28
Figure 17: Special Street Lights.....	29
Figure 18: Gateway Street Lights .....	30
Figure 19: Ceremonial Street Lights .....	31

# REVISED DRAFT

This Document is a draft pending final approval. Please contact a CCDC Planner at (619) 235-2200 to discuss your project.

## List of Figures–T

<i>Figure T-1: Asian Pacific Paving</i>	A-1
<i>Figure T-2: Ballpark District Paving</i>	A-2
<i>Figure T-3: Broadway Paving</i>	A-3
<i>Figure T-4: CCDC Standard Paving with 4'x4' Grid</i>	A-4
<i>Figure T-5: CCDC Standard Paving with 5'x5' Grid</i>	A-4
<i>Figure T-6: Children's Park Paving</i>	A-5
<i>Figure T-7: Gaslamp Quarter Paving–Basket Weave Pattern</i>	A-6
<i>Figure T-8: Gaslamp Quarter Paving–Running Bond Pattern</i>	A-6
<i>Figure T- 9: Gaslamp Quarter Paving–Herringbone Pattern</i>	A-6
<i>Figure T-10: Horton Plaza Paving</i>	A-7
<i>Figure T-11: Island Avenue Paving</i>	A-8
<i>Figure T-12: Little Italy Paving</i>	A-8
<i>Figure T-13: Market Street Paving</i>	A-9
<i>Figure T-14: Pacific Highway Paving</i>	A-10
<i>Figure T-15: ParK-to-Bay Paver</i>	A-11
<i>Figure T-16: ParK-to-Bay Paver (Layout)</i>	A-12
<i>Figure T-17: CCDC Standard Tree Grate –Four (4) Foot by Six (6) Foot Size</i>	A-13
<i>Figure T-18: CCDC Standard Tree Grate–Five (5) Foot by Five (5) Foot Size</i>	A-14
<i>Figure T-19: Special and Gateway Tree Grate–Four (4) Foot by Six (6) Foot Size</i>	A-15
<i>Figure T-20: Special and Gateway Tree Grate–Five (5) Foot by Five (5) Foot Size</i>	A-16
<i>Figure T-21: Ceremonial Tree Grate</i>	A-17
<i>Figure T-22: Asian Pacific Tree Grate</i>	A-18
<i>Figure T-23: Children's Park Tree Grate</i>	A-19
<i>Figure T-24: Park-to-Bay Tree Grate</i>	A-20
<i>Figure T-25: Standard Light (Type C)</i>	A-21
<i>Figure T-26: Enhanced Standard Light</i>	A-24
<i>Figure T-27: Gateway Light (Type A)</i>	A-27
<i>Figure T-28: Gaslamp Light</i>	A-30
<i>Figure T-29: Tear-Drop Fixture</i>	A-32
<i>Figure T-30: Asian Pacific Street Light Pole</i>	A-34
<i>Figure T-31: Asian Pacific Light</i>	A-36
<i>Figure T-32: CCDC Standard Litter Receptacle (Victor Stanley SD-42)</i>	A-38

# REVISED DRAFT

This Document is a draft pending final approval. Please contact a CCDC Planner at (619) 235-2200 to discuss your project.

## *I. INTRODUCTION*

The Centre City Streetscape Manual ("Manual") applies throughout the Centre City Community Plan Area and provides design standards for off-site improvements within the public right-of-way. This Manual supplements the City of San Diego Street Design Manual. All projects requiring building permits with a valuation that exceeds \$250,000, or those projects of lesser valuation, which involve new construction on vacant properties (either unimproved properties or where all existing structures have been removed), shall construct public improvements along the frontage(s) of the project pursuant to the design standards of this Manual. In addition, all work performed in the right-of-way, whether publicly or privately constructed, shall meet the standards of this Manual.

Public improvements are also guided by various planning documents and focus plans adopted by the City of San Diego City Council ("City Council") and the City of San Diego Redevelopment Agency. In the event of discrepancies or conflicts among the various plans or manuals, the standards of this Manual shall prevail. The President of the Centre City Development Corporation (CCDC), or the appropriate assignee, shall have the final decision regarding interpretation of this Manual.

Off-site improvement standards are administered by CCDC in cooperation with the City of San Diego Development Services Department and are reviewed at three stages: Basic Concept/Schematic level, fifty percent (50%) Design Development drawings, and Final Construction Drawings. In general, all items in the public right-of-way that are designed and constructed to the standards contained in this Manual will require a permit from the City of San Diego ("City").

In Centre City, the intensity of development is greater than in other areas of San Diego. This creates an opportunity to link activities by a network of pedestrian-oriented streets, public walkways, and public open spaces. A well-designed and planned public right-of-way will enhance the city's image, improve urban vitality and provide an efficient circulation system.

The objectives of this Manual are to:

1. Functionally and aesthetically integrate private development with the public rights-of-way;
2. Implement an aesthetically pleasing streetscape improvement program that establishes a sense of visual continuity throughout Centre City, and;
3. Create a pedestrian-oriented downtown area by requiring the construction of improvements that enhance the quality of the pedestrian environment, increases pedestrian safety and convenience, and encourages walking

## *II. ADMINISTRATION*

The President of CCDC, or the appropriate assignee, shall have the authority to grant exceptions to the standards contained in this Manual. Parties wishing an exception should apply in writing to the President, identifying the provision and location for which an exception is requested and clearly describing the design or material that the applicant wishes to substitute. Applicants shall not proceed with design or improvements without a written response from the President or the appropriate assignee.

# REVISED DRAFT

This Document is a draft pending final approval. Please contact a CCDC Planner at (619) 235-2200 to discuss your project.

## ***III. DESIGN INTENT***

The existing downtown neighborhoods are the basis for establishing the Manual planning areas. Each neighborhood reflects its own character through the use of street trees, sidewalk paving, and street lighting in the public right-of-way. The downtown neighborhoods include: the Ballpark District, Columbia, Core, Cortez, East Village, Gaslamp Quarter, Horton Plaza, Little Italy, and the Marina Sub Area (Figure 1). The Asian Pacific Thematic Historic District is a distinct area that overlaps several downtown neighborhoods. General recommendations for the Asian Pacific District are presented in this Manual; however the specific design standards for the Asian Pacific District are available from CCDC.

Each downtown street has been classified as a Neighborhood Street, Special Street, Gateway Street, or Ceremonial Street. These classifications were derived from the varying associated land uses, architecture, scale, and vehicular traffic that can be found in the downtown area. A particular street or project location should be checked to see what classification applies for each Improvement Category (Street Trees, Sidewalk Paving, and Street Lighting). All three Improvement Categories may not have the same classification on a street. For example, a street may be classified as a Special Street due to having special street trees designated, but still recommend standard paving and street lighting. Harbor Drive is under the jurisdiction of the San Diego Unified Port District, therefore improvements for Harbor Drive are not addressed in this Manual.

**Neighborhood Streets** are defined as the streets within each neighborhood that are not classified as being Special, Gateway, or Ceremonial. These streets are the basis for creating the character of that particular neighborhood.

**Special Streets** are designated due to the street having a unique character, purpose, or use that is needed on that particular street that helps describe that neighborhood. An example of this would be India Street in Little Italy, which is special because it creates a unique pedestrian-oriented environment in the heart of the Little Italy neighborhood.

**Gateway Streets** are defined as the major vehicular access routes into and out of the downtown area. The street character not only is designed to be perceived from a vehicle, but also from a pedestrian-oriented perspective.

**Ceremonial Streets** are defined as streets that are of symbolic and civic importance to the downtown area and create a significant and unique streetscape experience.

The street classifications defined in this Manual are unique to this Manual and should not be confused or interpreted as part of other ordinances, guidelines, or community plans used in the downtown area.

# REVISED DRAFT

This Document is a draft pending final approval. Please contact a CCDC Planner at (619) 235-2200 to discuss your project.

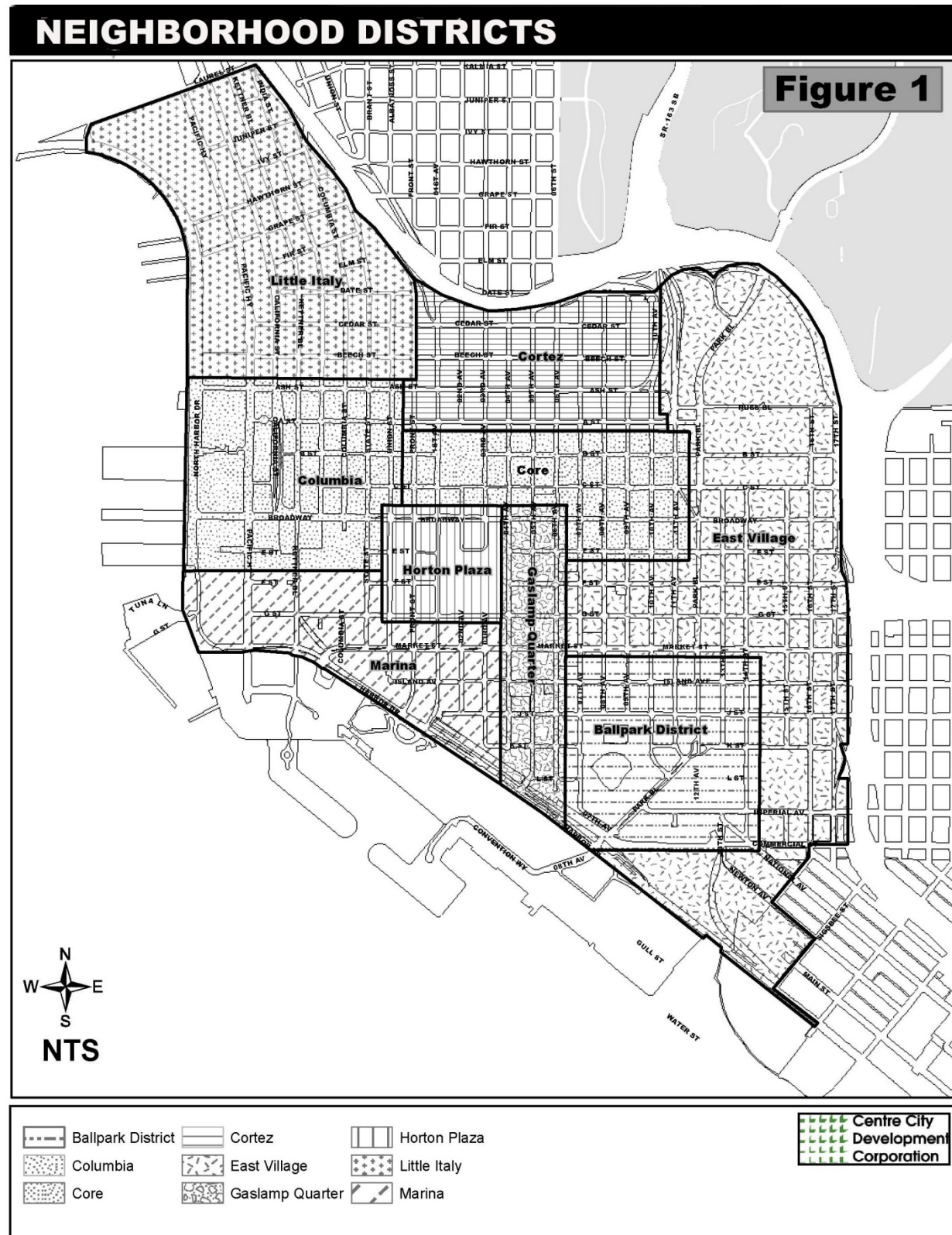

Figure 1: Neighborhood Districts

# REVISED DRAFT

This Document is a draft pending final approval. Please contact a CCDC Planner at (619) 235-2200 to discuss your project.

## IV. DESIGN STANDARDS

The following design standards apply to all streets regardless of their classification. See the street classifications under each category for the specific treatment of the sidewalk paving, street trees, and street lighting and the Technical Appendix for the specific product types to be installed. Site features not mentioned in this Manual shall be reviewed by CCDC on a project-by-project basis.

### Sidewalk Width

The predominant sidewalk width dimensions in downtown are **fourteen (14) to fifteen (15) feet**. Either width can accommodate pedestrians, street tree planting, and street furniture in compliance with the Americans with Disabilities Act (ADA) and Title 24. However, north-south streets west of Front Street typically have **twelve (12) foot** wide sidewalks. Given the existing historical development pattern in these areas, additional right-of-way dedication to widen sidewalks is not recommended.

### Standard Street Corner

Curbs for a standard street corner shall have a maximum **twenty (20) foot** radius. The curb radius may be reduced, upon approval by CCDC, where warranted by existing conditions. Parking should be prohibited within **ten (10) feet** from the point of return of the curb radius, with the curb painted red per City of San Diego standards (Figure 2).

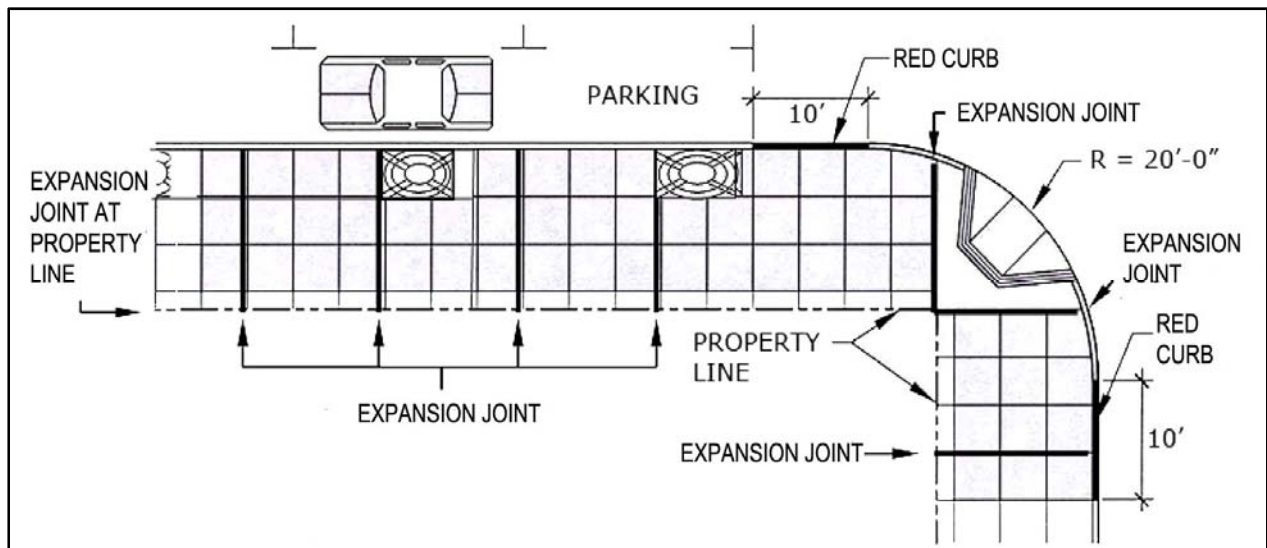

Figure 2: Standard Street Corner with Parking

### Street Corner Pop-Outs

Street corner pop-outs may be used on streets to emphasize pedestrian activity, mitigate traffic impacts, or enhance the streetscape. They should be used on streets and in areas where they are shown in a Master Plan and not on a project-by-project basis. Street corner pop-outs are permitted provided they meet the **twenty (20) foot** curb radius standard and provide for drainage and street sweeping equipment.

# REVISED DRAFT

This Document is a draft pending final approval. Please contact a CCDC Planner at (619) 235-2200 to discuss your project.

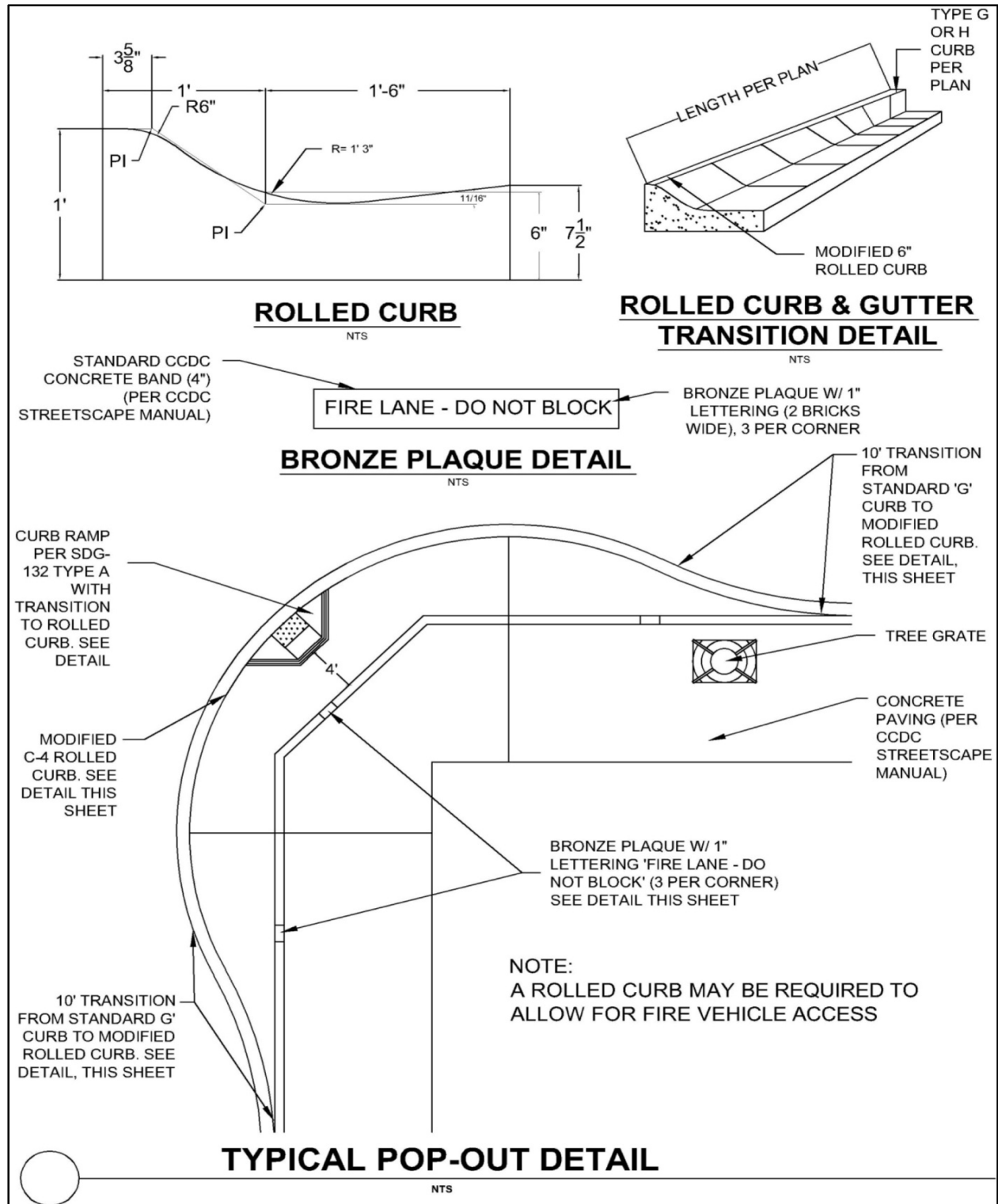

Figure 3: Sidewalk Pop-Outs

# REVISED DRAFT

This Document is a draft pending final approval. Please contact a CCDC Planner at (619) 235-2200 to discuss your project.

## Curbs, Gutters & Pedestrian Ramps

The design of curbs, gutters and pedestrian ramps should meet City of San Diego standard drawings. The pedestrian ramps should also meet current ADA and Title 24 standards. All curbs, gutters, and pedestrian ramps shall be colored per the CCDC Standard Paving found in the Technical Appendix and shall receive a heavy broom finish. Curb returns for vehicular access are not permitted at driveways.

## Clear Zones

A clear zone is designated at all street corners to permit unobstructed pedestrian circulation and increase visibility for both pedestrians and vehicles. The clear zone shall be defined as the area created by extending a line from each respective property line at the corner to the curb (Figure 4).

Within this clear zone, all lights, traffic control boxes, transformers, litter containers, mail and mail storage boxes, newspaper vending machines and booths, push carts, landscaping and planters, and pedestrian information signs are prohibited. The clear zone shall be kept free of traffic signals to the extent feasible.

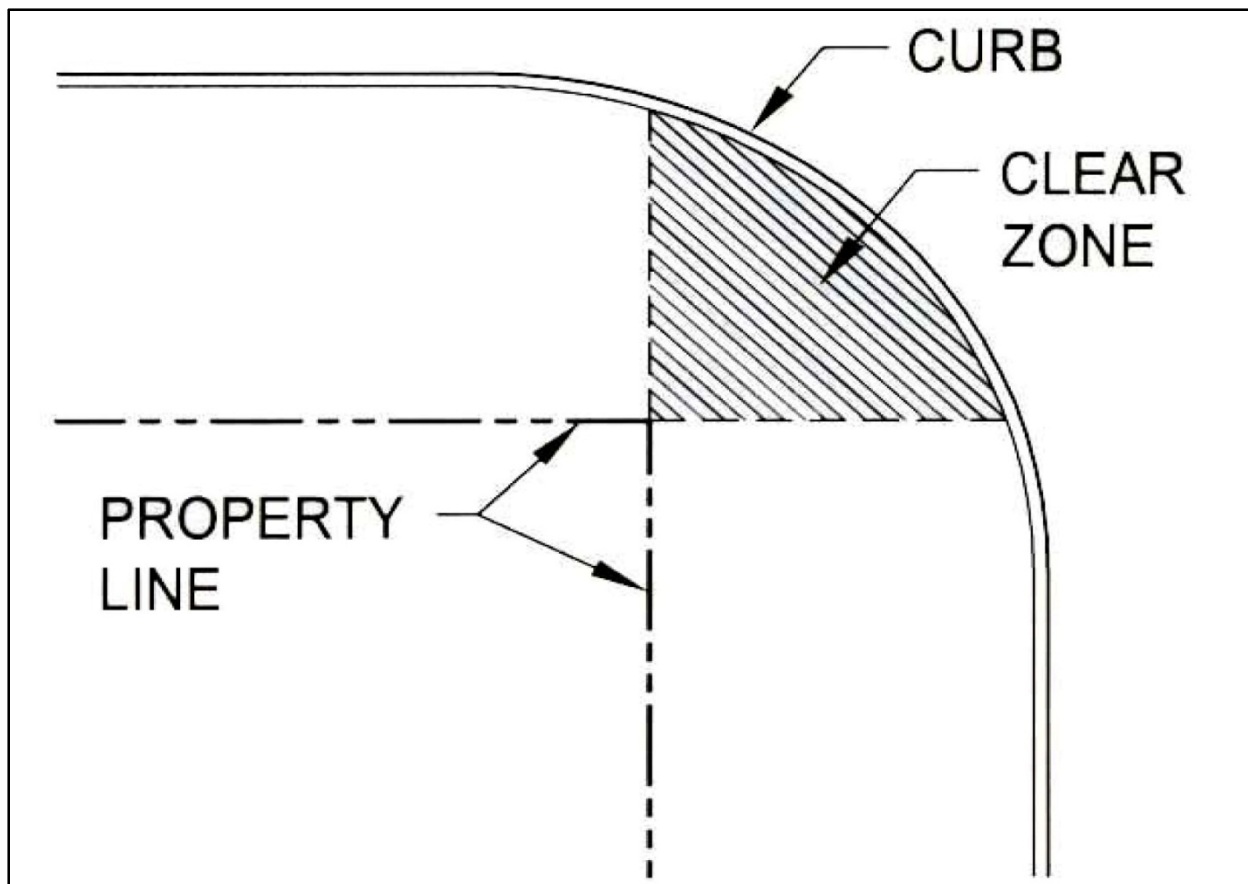

Figure 4: Clear Zone



# REVISED DRAFT

This Document is a draft pending final approval. Please contact a CCDC Planner at (619) 235-2200 to discuss your project.

## Street Lights

Street lights should be located approximately **seventy-five (75) to ninety-five (95) feet apart**; with three lights located on each 200-foot block frontage and four lights located on each 300-foot block frontage. Street lights should be triangulated on opposite sides of the street (Figure 5). When installed near street trees using **four (4) foot by six (6) foot** tree grates, the street lights are to be installed **two (2) feet** from the back of curb, measured from the back of curb to center of the pole base. When installed near street trees using **five (5) foot by five (5) foot** tree grates, the street lights are to be installed **two and a half (2½) feet** from the back of curb, measured from the back of curb to center of the pole base.

## Street Light Conformance

Design of street lighting systems shall conform to Section 209 Electrical Components of the "Greenbook" Standard Specifications for Public Works Construction, National Electric Code, Standard Special Provisions for Street Lighting and Traffic Signal Systems for the City of San Diego, Caltrans Standard Plans, applicable amendments, and this Manual. Gateway, Standard, Enhanced Standard, Type 15, and Tear-Drop light fixtures shall be induction. All acorn fixtures shall be Cutoff Optics (FCO) Type Fixture. An FCO Type Fixture is a luminaire or light fixture that, by design of the housing, reflector, lens and lamp assembly, does not allow any light dispersion or direct glare to shine above the horizontal plane measured from the lowest light emitting portion of the fixture as installed. The Gaslamp Fixture shall utilize induction lighting. See the Technical Appendix for precise specifications for the light standards proposed for the Centre City area.

## Street Trees

Generally, street trees should be spaced a maximum of **twenty-five (25) feet** on center and a minimum of **twenty (20) feet** on center along a street frontage. Double rows of trees on specified sidewalks shall be spaced appropriately. The tree spacing should be equal between the street lights. However, trees can be grouped and do not have to be equally spaced if alternative layouts are warranted due to conflicts with driveways, utilities, or other design elements, including design compatibility and tree species from an adjoining development. The trees must be spaced based on the following standards, as measured from the center of the tree trunk (Figure 6):

- **fifteen (15) feet** minimum from street lights
- **five (5) feet** minimum from driveway apron flares
- **twenty (20) feet** minimum from the front of any traffic signal or stop sign
- **ten (10) feet** minimum from the back of any traffic signal or stop sign
- **five (5) feet** minimum from underground utilities
- **ten (10) feet** minimum from sewer lines

When using **four (4) foot by six (6) foot** tree grates, street trees are to be installed **two (2) feet** from the back of curb, measured from the back of curb to the center of the trunk. When using **five (5) foot by five (5) foot** tree grates, street trees are to be installed **two and a half (2½) feet** from the back of curb, measured from the back of curb to the center of the trunk. In all cases, the tree should be centered in the tree grate. Street trees must be installed with an irrigation system designed by a registered Landscape Architect, root control barriers, and the tree grate that is specified for that particular street classification. Utilization of structural soil (see section 5) would allow for the elimination of the root control barrier and use of a smaller tree grate.

# REVISED DRAFT

This Document is a draft pending final approval. Please contact a CCDC Planner at (619) 235-2200 to discuss your project.

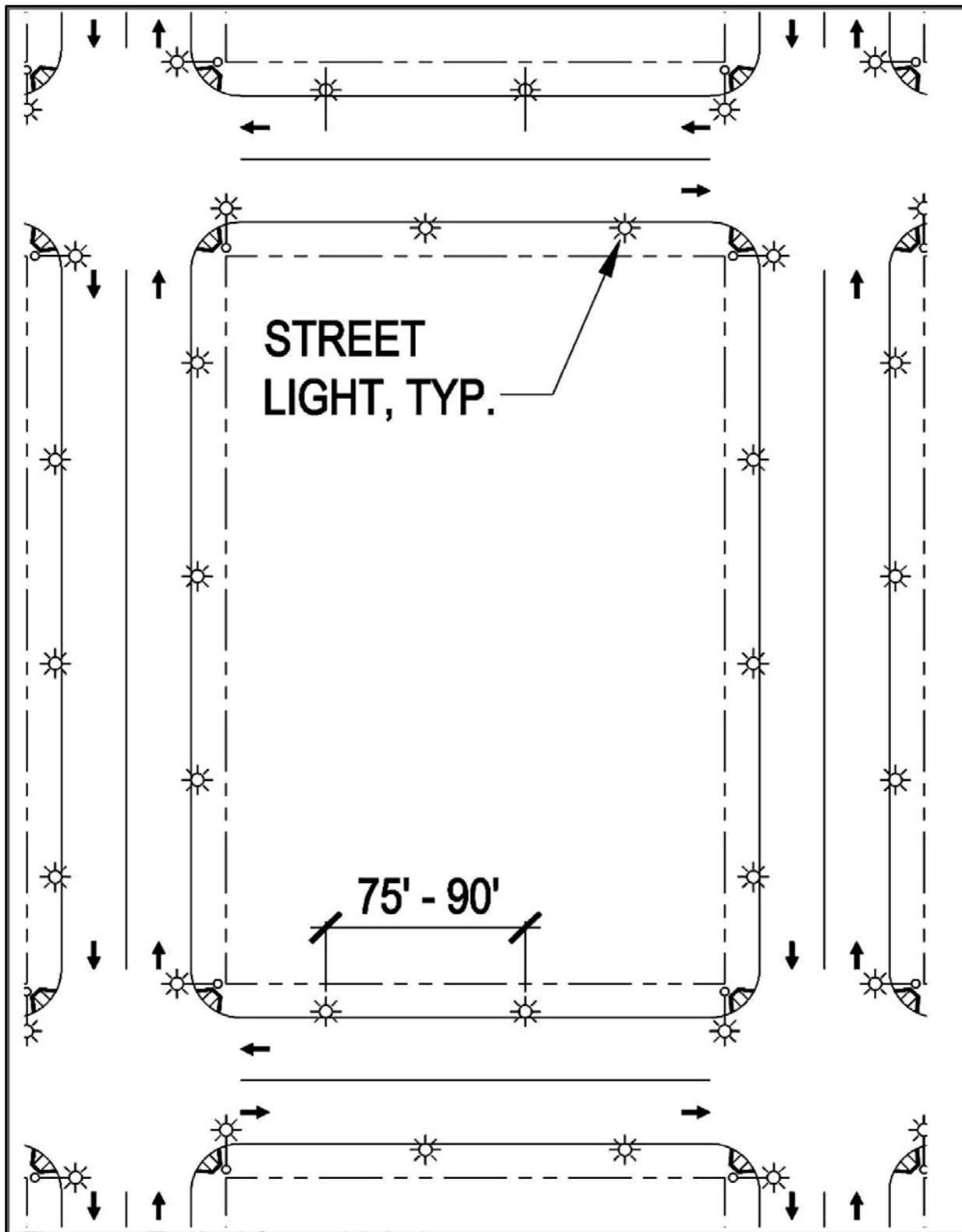

Figure 5: Typical Street Light Layout

# REVISED DRAFT

This Document is a draft pending final approval. Please contact a CCDC Planner at (619) 235-2200 to discuss your project.

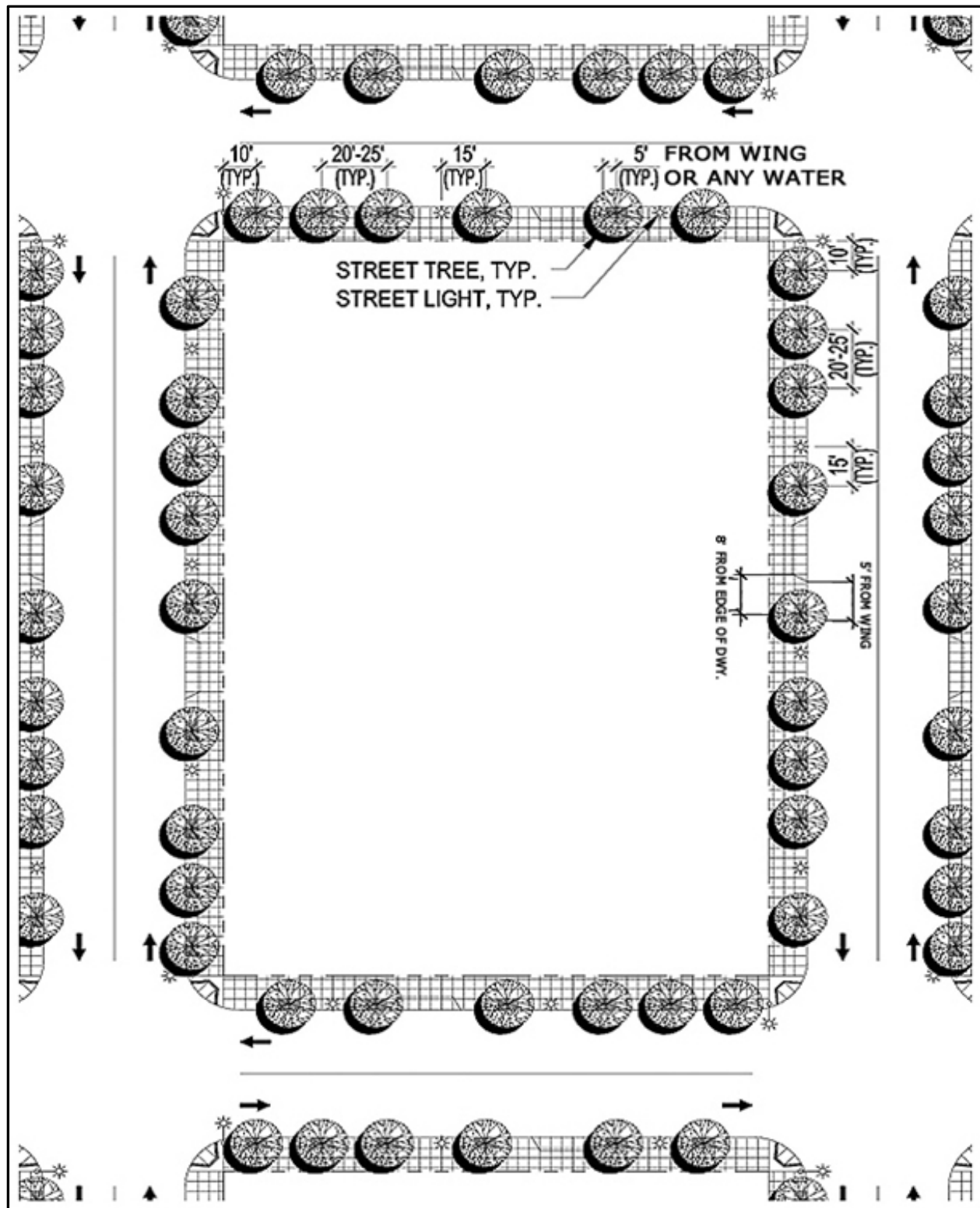

Figure 6: Typical Tree Layout

# REVISED DRAFT

This Document is a draft pending final approval. Please contact a CCDC Planner at (619) 235-2200 to discuss your project.

## Stoop and Planter Encroachment

For residential projects, minor encroachments into the right-of-way can provide enhanced pedestrian interest and a better interface between residential uses and busy downtown streets.

Stoop encroachments into individual residential units may be allowed if the unit is also provided with an accessible entry consistent with all applicable building codes. At-grade planters (maximum height is **two (2) feet**) may also be permitted. No fencing, gates, or other devices that privatize the area of encroachment shall be permitted. Stoop and planter encroachments may not exceed **three (3) feet** in depth for **fourteen (14) foot or wider** sidewalks (measured from property line to back of curb) or **two (2) feet** in depth for **twelve (12) to fourteen (14) foot** sidewalks (measured from property line to back of curb). No pots, plants, banners, railings, etc. shall hang over beyond the encroachment limit. All encroachments must be approved by a permit from the City.

## Underground Parking or Basements

Underground parking or basements, including any necessary shoring outside of the wall, shall be set back at least **six (6) feet** from the face of curb to provide adequate space for tree planting pits. All encroachments must be approved through the issuance of an Encroachment Maintenance and Removal Agreement (EMRA) or other documentation required by the City Development Services Department.

## Utility Covers, Mechanical Equipment & Transformer Vaults

Subsurface franchise utility equipment can be located under the sidewalk with the approval of CCDC and the City Engineer. All utility covers shall be cast-iron.

If practical, large covers shall be a fill-type lid covered with matching sidewalk material. Elevators and air exhaust and intake vents are prohibited in all new construction within the right-of-way.

Transformer vaults shall be placed within buildings. Pad-mounted transformers shall be installed on private property and an easement provided on the property. When unavoidable, pad-mounted transformers and other above-ground utility enclosures shall be located within five feet of the curb, preferably centered 2 feet from the back of curb to align with street lights and street trees unless approved otherwise by CCDC.

City traffic signal maintenance staff has authorized medium gray traffic signal cabinets (stainless steel should not be painted).

## Sidewalk Under Drains

Sidewalk underdrains shall be **three (3) inch** PVC or concrete per the City's Regional Standard Drawing D-27. For underdrains in brick paver, tile, or interlocking paver sidewalks, where the clearance for the Regional Standard underdrains is not achievable, a rectilinear under drain may be used. All manifolds from downspouts to underdrains shall be outside of the public right-of-way. Underdrain sizing shall be dependent on the drainage flow determined in the project hydrology study. All underdrains shall run perpendicular/45° to the sidewalk and align with a scoreline or expansion joint. D-25 Storm drains shall be constructed of the same sidewalk concrete to match the surrounding sidewalk in appearance.

# REVISED DRAFT

This Document is a draft pending final approval. Please contact a CCDC Planner at (619) 235-2200 to discuss your project.

## Litter Receptacles

Litter receptacles are required for new development exceeding **one hundred (100) linear feet** or more of street frontage. The perimeter of each full block shall have at least **four (4)** litter receptacles located on each corner of the Clear Zone. Midblock litter receptacles shall be placed only on north and south streets when located on a designee main or commercial street. Litter receptacles shall be installed with the steel door facing away from the street.

## Newspaper Vending Machines

Newspaper vending machines are prohibited from all clear zones and transit stops and shall not restrict the loading and unloading of passengers or freight where curbs are marked for such activities. Newspaper vending machines should be located next to a red curb not marked for a bus stop or in niches in the building facade. See the San Diego Municipal Code, Chapter 6: Article 2, Division 10. Special cases may be made for multiple enclosures. Newspaper vending machines in the Gaslamp District are located in the newspaper corrals per City Ordinance

## Sidewalk Cafés

Sidewalk café within the public right-of-way are subject to CCDC approval and the regulations in Chapter 14: Article 1, Division 6 of the City's Land Development Code.

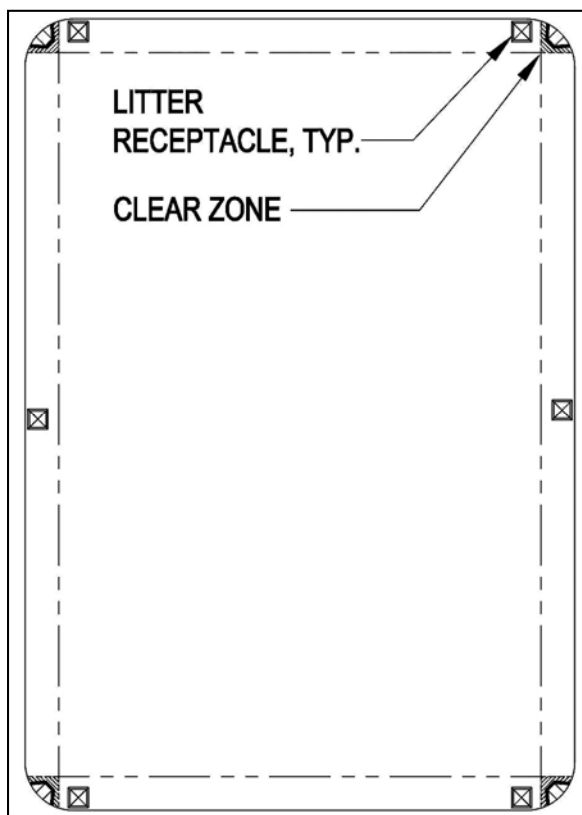

Figure 7: Typical Receptacle Layout

# REVISED DRAFT

This Document is a draft pending final approval. Please contact a CCDC Planner at (619) 235-2200 to discuss your project.

## ***V. SPECIFIC RECOMMENDATIONS***

Street trees, sidewalk paving, and street lighting are the key elements used to create the urban character for each of the street classifications. The specific recommendations below are divided into three basic categories, Street Trees, Sidewalk Paving and Street Lighting.

### **STREET TREES**

The street tree program was developed to emphasize the individual neighborhoods of the downtown area and highlight the Special, Gateway, and Ceremonial streets through distinctive tree plantings. Existing mature, healthy trees, regardless of the proposed street tree designation, may be retained based on a case-by-case evaluation by CCDC, in consultation with City staff.

The minimum size street tree shall be a **thirty-six (36) inch** boxed tree or **fifteen (15) foot** brown trunk height for palms. Planter spaces should be a minimum interior dimension of **four (4) feet by six (6) feet** or **five (5) feet by five (5)**, be flush with the sidewalk, and have a tree grate. All trees shall be planted in the ground. Above-ground planter boxes are not permitted unless existing conditions prevent in-ground planting.

#### ***Permits for Removal and Addition of Street Trees***

The permit process for removal and addition of street trees within downtown areas shall follow the City guidelines. Per the City Street Division Services website (<http://www.sandiego.gov/street-div/maintenance.shtml>), it states:

"Only dead trees, or trees deemed an immediate hazard are removed from the right-of-way as soon as possible. All other removal requests are evaluated for preservation or removal, per Council Policy 200-5. If the City determines the tree must be removed in order to repair other infrastructure, concurrence of the abutting property owner is required. The tree will be included on a list of proposed street tree removals, which is sent monthly to the City Council, Community Forest Advisory Board and all community planning groups. If no objection to the proposed removal is received, the tree will be removed by City contractors. This includes full stump grinding. It can take up to 48 months from the determination date for the City to remove the tree and make any permanent concrete repairs. During this period, temporary asphalt ramping will be installed to alleviate any hazards in the public right-of-way. Property owners may expedite this process by agreeing to repair any associated damages from the tree if removal meets criteria in Council Policy 200-5."

#### ***Tree Grates***

Tree grates shall meet safety requirements of ADA and Title 24 of the State Administrative Code. The tree grate shall be installed flush with adjacent paving in a one-piece steel frame unit embedded in concrete and be anti-pilfer equipped (two-piece steel frame units will be allowed when installed around existing trees). The standard size tree grates shall be either **four (4) foot by six (6) foot** or **five (5) foot by five (5) foot** designs. Edges of tree grates should be aligned with score lines and/or expansion joints and adjacent to the concrete curb and gutter. Metal grates shall be factory primed and painted black. See the Technical Appendix for product requirements and the Construction Detail Appendix for standard installation.

# REVISED DRAFT

This Document is a draft pending final approval. Please contact a CCDC Planner at (619) 235-2200 to discuss your project.

Tree grates shall correspond to the following classifications:

District Streets	CCDC Standard Tree Grate
Special Streets	Special Tree Grate
Gateway Street	Gateway Tree Grate
Ceremonial Street	Ceremonial Tree Grate
Asian Pacific Paving	Asian Pacific Tree Grate
Children's Park Paving	Children's Park Tree Grate
Little Italy Paving	Little Italy Tree Grate
Park-to-Bay Paving	Park-to-Bay Tree Grate

## *Root Control Barriers*

A root control barrier shall be provided for each tree to avoid possible root damage to sidewalks, surrounding buildings, and other elements of the public right-of-way or surrounding buildings. Root control barriers shall be installed at the edge of paving or building, not around the rootball. See the Technical Appendix for product requirements and the Construction Detail Appendix for standard installation.

## *Structural Soil*

Structural soil may be specified when the tree planting area is less than **twenty-four (24) square feet**, in lieu of utilizing a root control barrier, or as approved by CCDC due to restrictive site conditions. The structural soil shall be installed to a **twenty four (24) inch to thirty-six (36) inch** depth from the back of curb to the property line. Installing structural soil would allow the use of a **four (4) foot by four (4) foot** tree grate instead of the standard tree grate sizes. See the Specification Appendix for standard installation and product requirements.

## *Street Tree Irrigation*

A permanent irrigation system for street trees shall be designed by a registered Landscape Architect and shall include:

1. A separate irrigation water meter used solely for landscaping within the right-of-way, with the meter fees paid for by the property owner.
2. A backflow prevention device installed immediately downstream of the water meter. All private backflow prevention devices shall be installed outside of the right-of-way, and within a lockable, steel enclosure or locked utility room.
3. An automatic controller within a lockable stainless steel enclosure. All private automatic irrigation controllers shall be located outside of the right-of-way within the building in a lockable, steel enclosure or locked utility room. If a solar controller is specified, it may be located in the right-of-way in a location that does not interfere with pedestrian circulation or vehicular visibility.
4. Pipe shall be in place prior to installing the sidewalk paving. Irrigation pipe under paving shall be sleeved with Schedule 40 PVC that is twice the diameter of the pipe it serves and shall only have one pipe per sleeve. Irrigation shall meet the requirements of the City's Land Development Code.
5. A minimum of **two (2)** bubbler-type heads or approved equal per street tree.

# REVISED DRAFT

This Document is a draft pending final approval. Please contact a CCDC Planner at (619) 235-2200 to discuss your project.

6. Pop-up spray irrigation heads or a drip irrigation system for shrub and groundcover planting areas.
7. Remote control valves with a brass body and located in individual concrete valve boxes. If the water flow is below **five (5)** gallons per minute, a plastic body valve may be used.
8. Globe valves to divide the system into controllable units, with a brass body and installed in a concrete valve box.
9. Quick coupling valves located at **one hundred (100)** foot intervals or as needed to service the area and be installed in a concrete valve box.
10. A rain sensing device located outside of the right-of-way, with the device unobstructed to the sky.
11. Concrete valve boxes with cast-iron lids. The clevis pin and sheet metal clip shall be replaced with a marine type, stainless steel machine bolt and self-locking nut.

*Street Tree Classifications (see Appendix for photographs of designated trees)*

*District Street Trees (see Figure 8):*

DISTRICT	STREET TREES
Ballpark District	see <b>Special Street Trees</b> (Figure 9)
Columbia, Core	<b>Fern Pine</b> ( <i>Podocarpus gracillior</i> )
Cortez (Hill)	<b>Jacaranda</b> ( <i>Jacaranda mimosifolia</i> )
Cortez (West)	<b>Carrot Wood</b> ( <i>Cupaniopsis anacardioides</i> )
East Village, Horton Plaza	<b>Chinese Evergreen Elm</b> ( <i>Ulmus parvifolia</i> )
Gaslamp Quarter	<b>Bradford Pear</b> ( <i>Pyrus calleryana</i> 'Bradford')
Little Italy	see <b>Special Street Trees</b> (Figure 9)
Marina	<b>Raywood Ash</b> ( <i>Fraxinus oxycarpa</i> )



# REVISED DRAFT

This Document is a draft pending final approval. Please contact a CCDC Planner at (619) 235-2200 to discuss your project.

## *Special Street Trees (see Figure 9):*

<b>STREET</b>	<b>STREET TREES</b>
1 <sup>st</sup> Ave. (Harbor Dr. to G St.), Front St. (Harbor Dr. to G St.)	Raywood Ash ( <i>Fraxinus oxycarpa</i> ), Double Row
3 <sup>rd</sup> Ave. (Market St. to J St.), Island Ave. (2 <sup>nd</sup> Ave. to 6 <sup>th</sup> Ave.), L St. (5 <sup>th</sup> Ave. to 6 <sup>th</sup> Ave. on south side of street and 6 <sup>th</sup> Ave. to 7 <sup>th</sup> Ave. on north side of street), State St. (north of Ash St.)	Chinese Flame Tree ( <i>Koelreutaria bipinnata</i> )
7 <sup>th</sup> Ave. (south of Market St.), 8 <sup>th</sup> Ave. (south of Market St.), 9 <sup>th</sup> Ave. (south of Market St.)	Brisbane Box ( <i>Tristania conferta</i> )
12 <sup>th</sup> Ave. (K St. to Imperial Ave.), Beech St. (Pacific Highway to Union St.), Date St., Elm St., Fir St., Ivy St., Juniper St., K St. (10 <sup>th</sup> Ave. to 14 <sup>th</sup> St.), Kalmia St., Kettner Blvd. (Ash St. to Date St.)	Jacaranda ( <i>Jacaranda mimosifolia</i> )
13 <sup>th</sup> St. (south of Market St.), 14 <sup>th</sup> St. (south of Market St.)	Evergreen Ash ( <i>Fraxinus uhdei</i> )
C St. (west of Park Blvd.)	Carrot Wood ( <i>Cupaniopsis anacardioides</i> )
Cedar St. (Pacific Highway to Columbia St.)	Double row of Jacaranda ( <i>Jacaranda mimosifolia</i> )
Columbia St. (north of Ash St.), Commercial St. (west of 14 <sup>th</sup> St.), J St. (east of 4 <sup>th</sup> Ave.), K St. (between 4 <sup>th</sup> Ave. and 7 <sup>th</sup> Ave.), L St. (east of 14 <sup>th</sup> St.), Union St. (north of Ash St.)	Raywood Ash ( <i>Fraxinus oxycarpa</i> )
Frontage Rd.	Chanticleer Pear ( <i>Pyrus calleryana</i> 'Chanticleer')
India St. (Ash St. to Laurel St.)	Chinese Tallow ( <i>Sapium sebiferum</i> )
Island Ave. (east of 6 <sup>th</sup> Ave.)	Chinese Evergreen Elm ( <i>Ulmus parvifolia</i> )
L St. (5 <sup>th</sup> Ave. to 6 <sup>th</sup> Ave. on north side of street, and 6 <sup>th</sup> Ave. to 7 <sup>th</sup> Ave. on south side of street)	Mexican Fan Palm ( <i>Washingtonia robusta</i> )
Kettner Blvd. (Date St. to Laurel St.)	Queen Palm ( <i>Syagrus romanzoffianum</i> ) and Chinese Pistache ( <i>Pistacia chinensis</i> ) alternating

\* Raywood Ash (*Fraxinus oxycarpa*) may be planted in areas to match/replace existing Palo Alto trees.

# REVISED DRAFT

This Document is a draft pending final approval. Please contact a CCDC Planner at (619) 235-2200 to discuss your project.

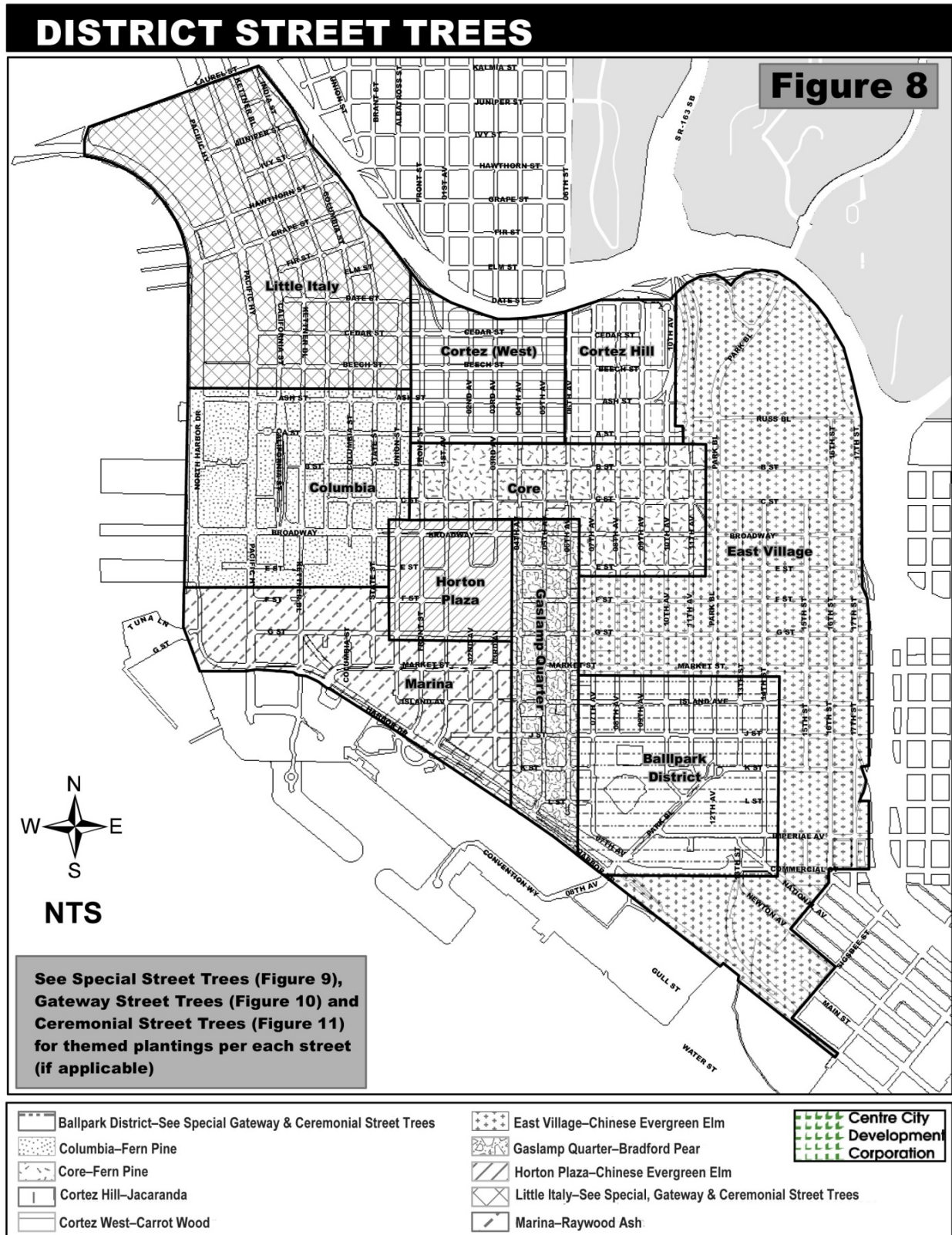
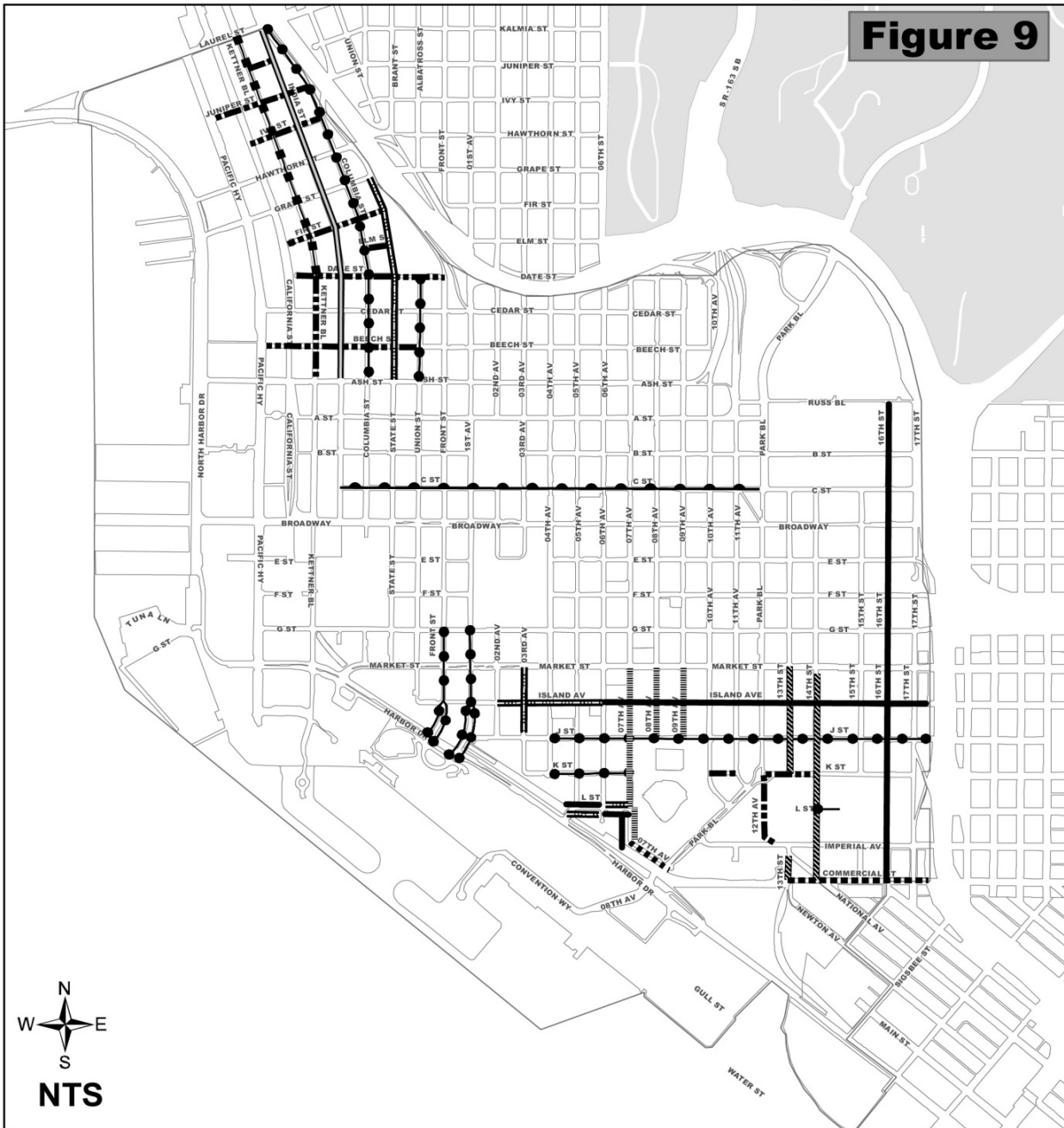

**Figure 8: District Street Trees**

# REVISED DRAFT

This Document is a draft pending final approval. Please contact a CCDC Planner at (619) 235-2200 to discuss your project.

## SPECIAL STREET TREES



**Figure 9**

	Chinese Pistache		Chinese Tallow (Mix of trees no. of Grape/City Approval)	
	Brisbane Box		Evergreen Ash	
	Carrot Wood		Jacaranda	
	Chanticleer Pear		London Plane	
	Chinese Evergreen Elm		Raywood Ash	
	Chinese Flame Tree			

Figure 9: Special Street Trees

# REVISED DRAFT

This Document is a draft pending final approval. Please contact a CCDC Planner at (619) 235-2200 to discuss your project.

## *Gateway Street Trees (see Figure 10):*

STREET	STREET TREES
1st Ave. (north of G St.), 10th Ave. (south of Ash St.), 11th St., A St., Ash St., Front St. (north of G St.)	Jacaranda ( <i>Jacaranda mimosifolia</i> )
F St. (east of 6th Ave.), G St. (west of 4th Ave. and east of 6th Ave.)	Chinese Flame Tree ( <i>Koelreutaria bipinnata</i> )
Pacific Highway	Mexican Fan Palm ( <i>Washingtonia robusta</i> )
Grape St.	Mexican Fan Palm ( <i>Washingtonia robusta</i> ), Jacaranda ( <i>Jacaranda mimosifolia</i> ) alternating
Hawthorn St.	Mexican Fan Palm ( <i>Washingtonia robusta</i> ), Raywood Ash ( <i>Fraxinus oxycarpa</i> ) alternating
Laurel St.	Queen Palm ( <i>Syagrus romanzoffianum</i> )

## *Ceremonial Street Trees (see Figure 11):*

STREET	STREET TREES
Broadway	Southern Magnolia ( <i>Magnolia grandiflora</i> )
Cedar St. (west of 1st Ave.)	Jacaranda ( <i>Jacaranda mimosifolia</i> ) Double row west of Columbia St.
Imperial Ave., Market St. (west of 4th Ave. and east of 6th Ave.)	Raywood Ash ( <i>Fraxinus oxycarpa</i> )
13th St., Park Boulevard (north of K St.)	Yarwood London Plane Tree ( <i>Platanus acerifolia</i> 'Yarwood')
Park Boulevard (south of K St.)	Tipu Tree ( <i>Tipuana tipu</i> )

# REVISED DRAFT

This Document is a draft pending final approval. Please contact a CCDC Planner at (619) 235-2200 to discuss your project.

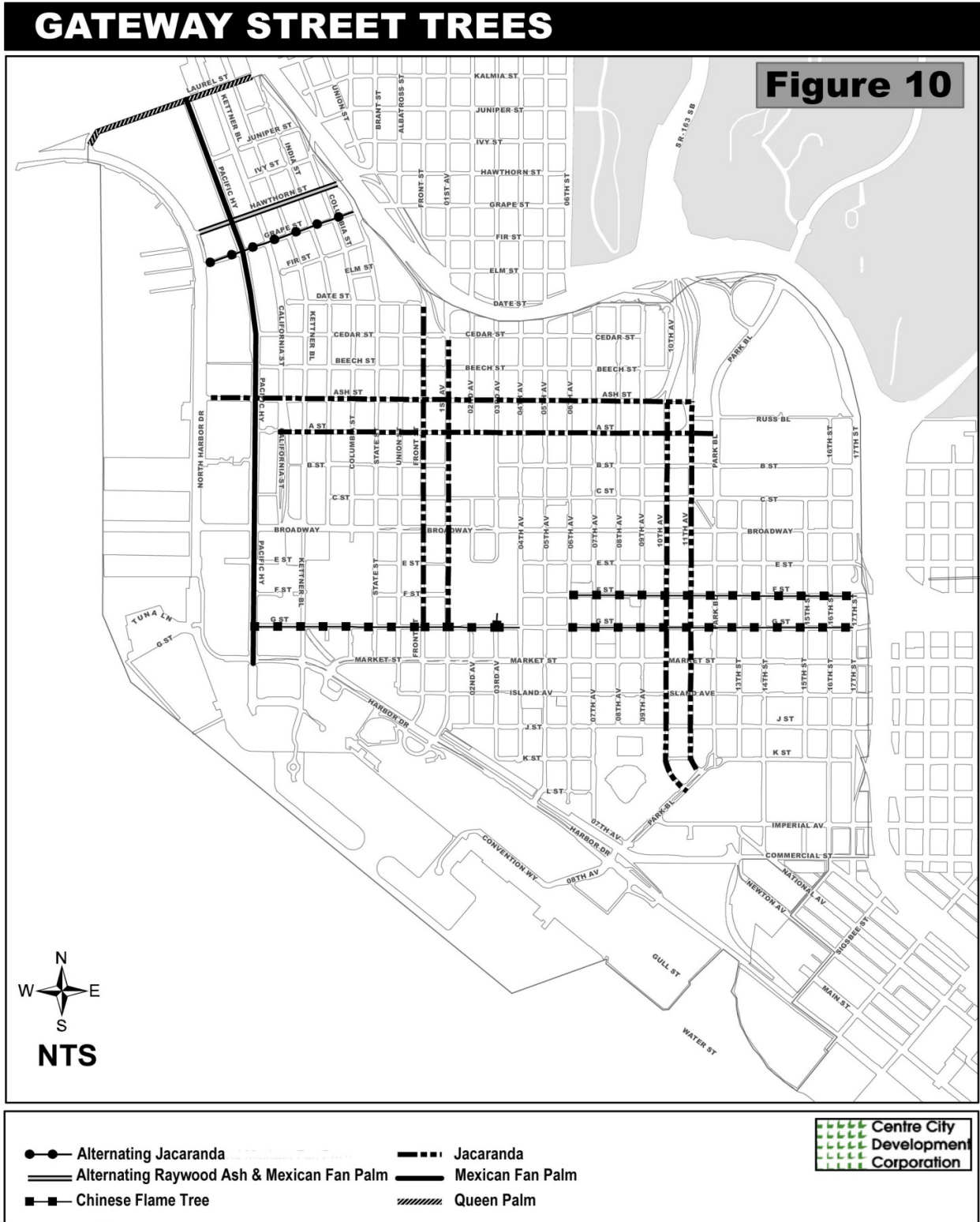

Figure 10: Gateway Street Trees



# REVISED DRAFT

This Document is a draft pending final approval. Please contact a CCDC Planner at (619) 235-2200 to discuss your project.

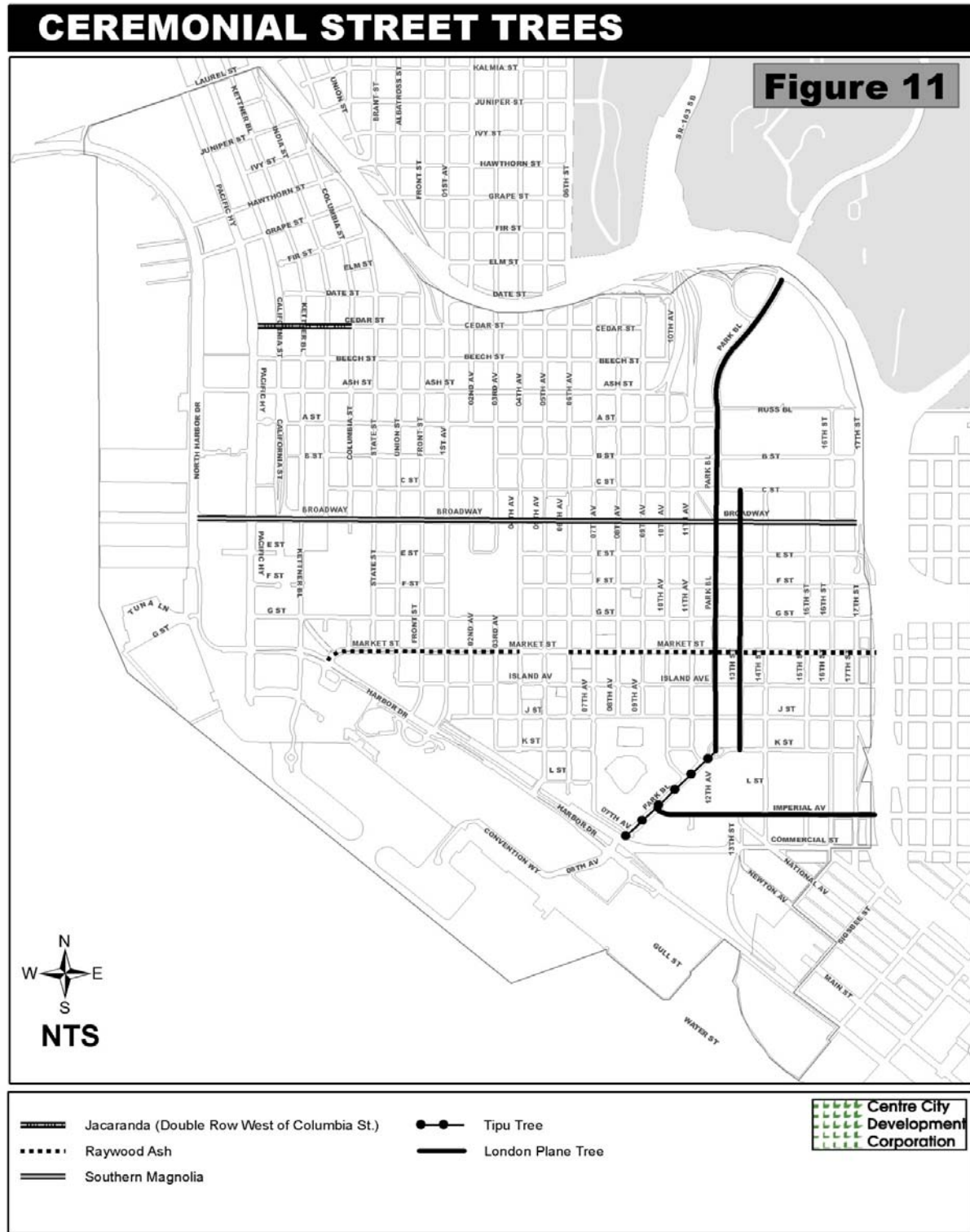

Figure 11: Ceremonial Street Trees

# REVISED DRAFT

This Document is a draft pending final approval. Please contact a CCDC Planner at (619) 235-2200 to discuss your project.

## SIDEWALK PAVING

The design of sidewalk paving should be carefully coordinated between on-and off-site areas. The objective is to design paved surfaces that flow together, thus avoiding sharp changes in design, color, quality and materials at the property line.

Each project shall meet the minimum standards, although the actual design should vary to meet conditions of individual sites. However, the materials, colors and surface textures should be precisely consistent with those specified for each class of improvement. The driveway apron and curb inlet top should continue the sidewalk paving pattern materials.

The sidewalk paving program for downtown is structured to allow the paving to compliment the surrounding architecture and to emphasize the Special, Gateway, and Ceremonial Streets.

### *Sidewalk Paving Classifications:*

Each paving classification below is described in detail in the Technical Appendix:

#### *District Sidewalk Paving* (see Figure 12):

DISTRICT	SIDEWALK PAVING
Ballpark District	Ballpark District Paving (Figure T-2)
Columbia, Core, Cortez, East Village	CCDC Standard Paving (Figure T-Error! Reference source not found.4 and Figure T-5)
Gaslamp Quarter	Gaslamp Quarter Paving (Figure T-7, Figure T-8 and Figure T-9)
Horton Plaza	Horton Plaza Paving (Figure T-10)
Little Italy	Little Italy Paving (Figure T-12)
Marina	Marina Paving

#### *Special Sidewalk Paving* (see Figure 13).

STREET	SIDEWALK PAVING
1 <sup>st</sup> Ave. (Harbor Dr. to G St.), Front St. (Harbor Dr. to G St.),	Children's Park Paving (Figure T-6)
3 <sup>rd</sup> Ave. (Market St. to J St.), Island Ave. (2 <sup>nd</sup> Ave. to 6 <sup>th</sup> Ave.)	Asian Pacific Paving (Figure T-1)
4 <sup>th</sup> Ave. (Broadway to C St.), 5 <sup>th</sup> Ave. (Broadway to C St.), 6 <sup>th</sup> Ave. (Broadway to C St.)	Broadway Paving (T-3)
C St. (west of Park Blvd.)	Terra Cotta Tile Paving
Island Ave. (east of 6 <sup>th</sup> Ave.)	Island Avenue Paving (Figure T-11)

# REVISED DRAFT

This Document is a draft pending final approval. Please contact a CCDC Planner at (619) 235-2200 to discuss your project.

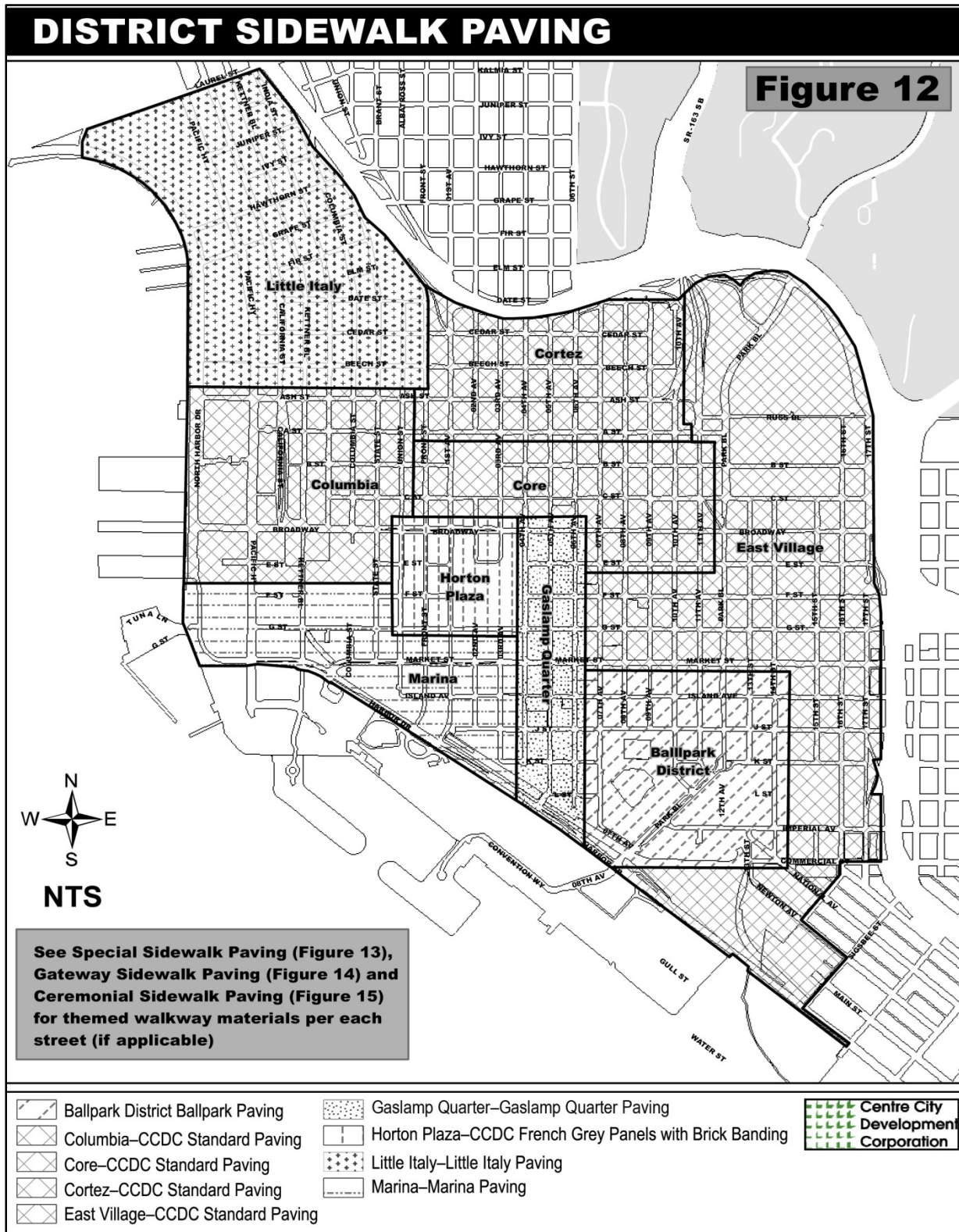

Figure 12: District Sidewalk Paving



# REVISED DRAFT

This Document is a draft pending final approval. Please contact a CCDC Planner at (619) 235-2200 to discuss your project.

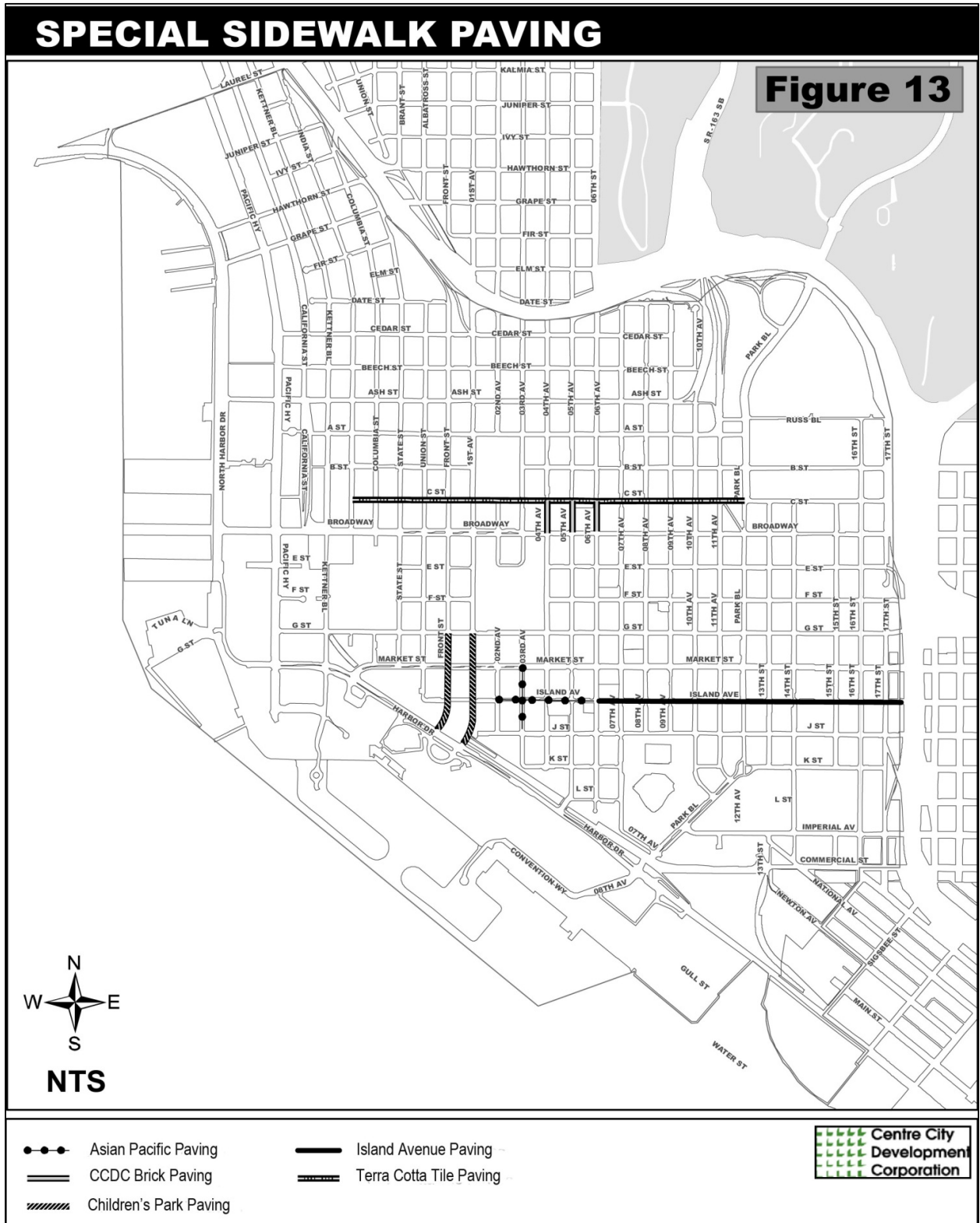

Figure 13: Special Sidewalk Paving

# REVISED DRAFT

This Document is a draft pending final approval. Please contact a CCDC Planner at (619) 235-2200 to discuss your project.

## *Gateway Sidewalk Paving* (see Figure 14):

<b>STREET</b>	<b>SIDEWALK PAVING</b>
10 <sup>th</sup> Ave. (Ash St. to Market St.), 11 <sup>th</sup> Ave. (north of Market St.), A St., F St. (east of 6 <sup>th</sup> Ave.), G St. (west of 4 <sup>th</sup> Ave. and east of 6 <sup>th</sup> Ave.)	Gateway Sidewalk Paving (Figure 14)
Ash St.	CCDC Brick Paving
Pacific Highway (south of Ash St.)	Pacific Highway Paving (Figure T-14)

## *Ceremonial Sidewalk Paving* (see Figure 15):

<b>STREET</b>	<b>SIDEWALK PAVING</b>
Broadway	Broadway Paving (Figure T-3)
Harbor Dr.	under Port of San Diego jurisdiction
Imperial Ave.	Ballpark Paving (Figure T-2)
Market St. (west of 4 <sup>th</sup> Ave, and east of 6 <sup>th</sup> Ave.)	Market St. Paving (Figure T-13)
Park Boulevard (north of K St.)	Park-to-Bay Paving (Figure T-15 and Figure T-16)

# REVISED DRAFT

This Document is a draft pending final approval. Please contact a CCDC Planner at (619) 235-2200 to discuss your project.

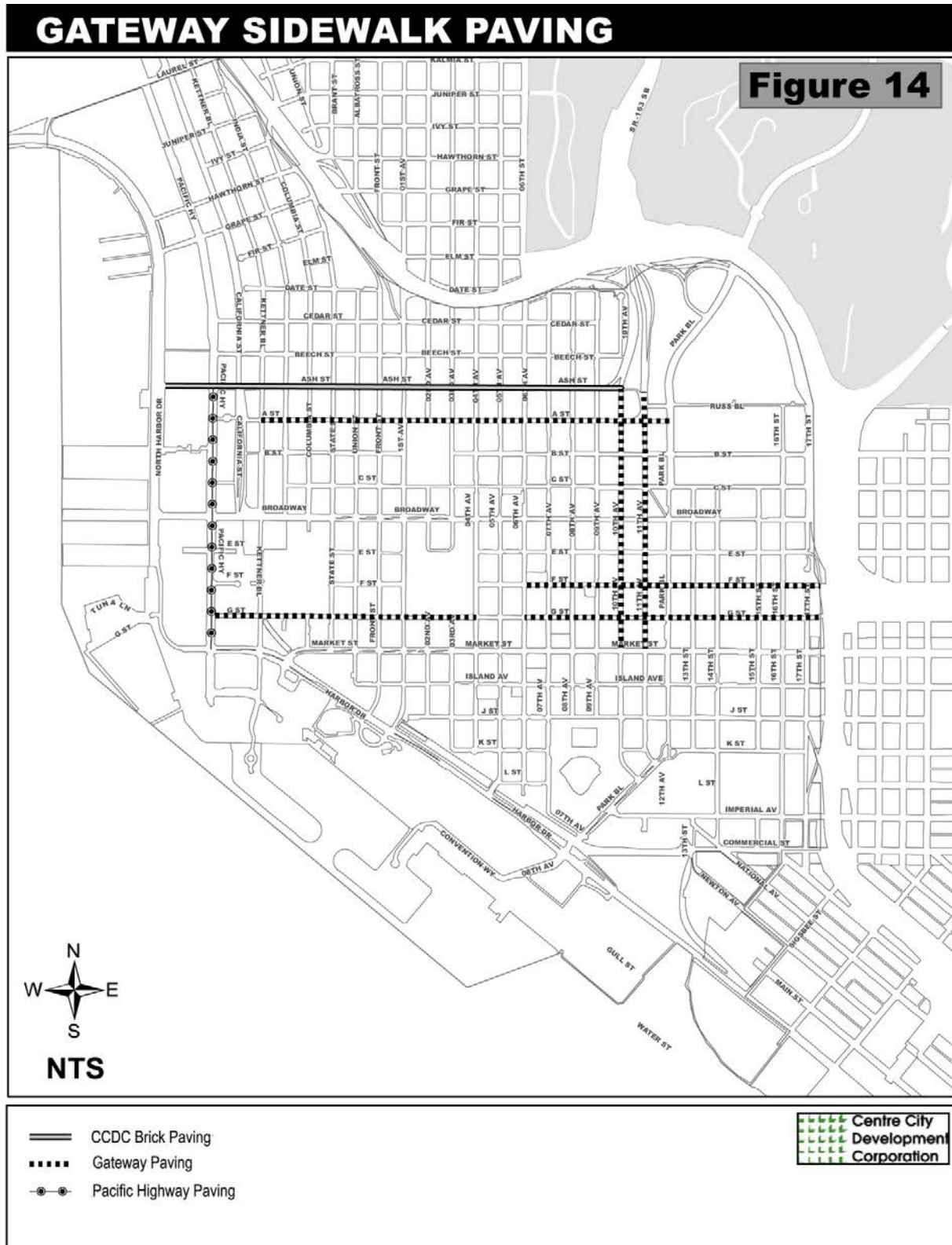

Figure 14: Gateway Sidewalk Paving

# REVISED DRAFT

This Document is a draft pending final approval. Please contact a CCDC Planner at (619) 235-2200 to discuss your project.

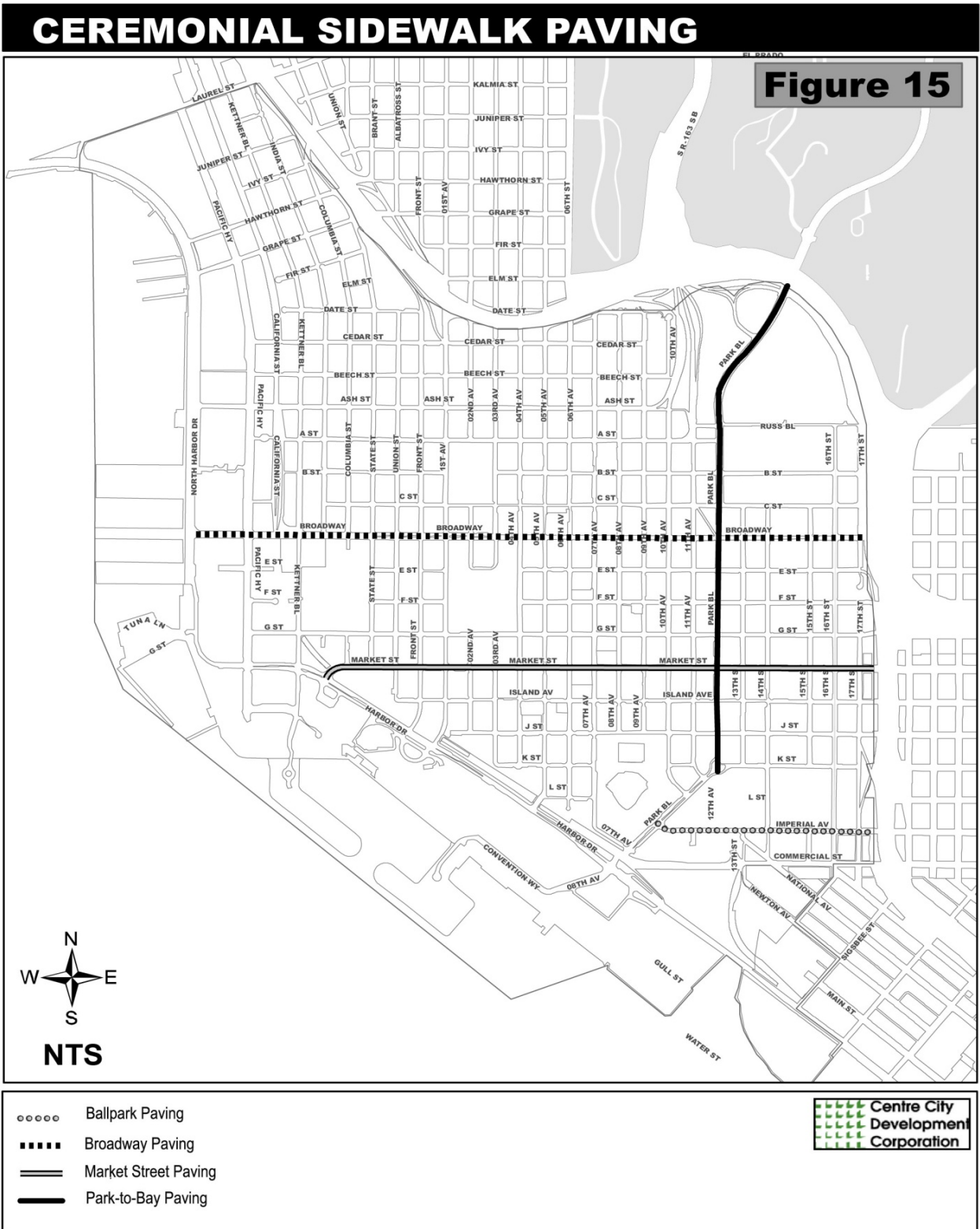

Figure 15: Ceremonial Sidewalk Paving

# REVISED DRAFT

This Document is a draft pending final approval. Please contact a CCDC Planner at (619) 235-2200 to discuss your project.

## ***STREET LIGHTING***

The street lighting program for downtown includes Standard, Enhanced Standard, Gateway, Gaslamp, Asian Pacific and Tear-Drop Lights. These light standards are designed primarily for mid-block lighting. All signalized intersections shall utilize Type 15 cobra head fixtures per City requirements. Operation of the street light systems shall be photo-electric control unit unless otherwise shown.

### ***Street Lighting Classifications:***

***District Street Lights*** (see Figure 16):

<b>DISTRICT</b>	<b>STREET LIGHT</b>
Ballpark District, Columbia, Core, Cortez, East Village, Marina	Standard Light —Type C (Figure T-25))
Gaslamp Quarter	Gaslamp Light (Figure T-28)
Horton Plaza	Gateway Light—Type A (Figure T-27)
Little Italy	Enhanced Standard Light (Figure T-26)

***Special Street Lights*** (see Figure 17):

<b>STREET</b>	<b>STREET LIGHT</b>
4th Ave. (Broadway to C St.), 5th Ave. (Broadway to C St.), 6th Ave. (Broadway to C St.), Kettner Blvd. (Ash St. to Laurel St.)	Enhanced Standard Light (Figure T-26)
3rd Ave. (Market St. to J St.), Island Ave. (2nd Ave. to 6th Ave.)	Asian Pacific Light (Figure T-30 and Figure T-31)
C St. (west of Park Blvd.)	Special per MTDB (Induction Shoebox Lights)
J St. (6th Ave. to 14th St.)	Gateway Light—Type A (Figure T-27)

***Gateway Street Lights*** (see Figure 18):

<b>STREET</b>	<b>STREET LIGHT</b>
1st Ave., 10th Ave. (south of Ash St.), 11th Ave., A St., Ash St., F St. (east of 6th Ave.), Front St., G St. (west of 4th Ave. and east of 6th Ave.), Grape St., Hawthorn St., Laurel St., Pacific Highway	Gateway Light —Type A (Figure T-27)

***Ceremonial Street Lights*** (see Figure 19):

<b>STREET</b>	<b>STREET LIGHT</b>
Broadway, Cedar St. (west of 1st Ave.), Imperial Ave., Market St. (west of 4th Ave. and east of 6th Ave.)	Gateway Light —Type A (Figure T-27)
Harbor Dr.	under Port of San Diego jurisdiction
Park Blvd.	Tear-Drop Light (Figure T-29)



# REVISED DRAFT

This Document is a draft pending final approval. Please contact a CCDC Planner at (619) 235-2200 to discuss your project.

## DISTRICT STREET LIGHTS

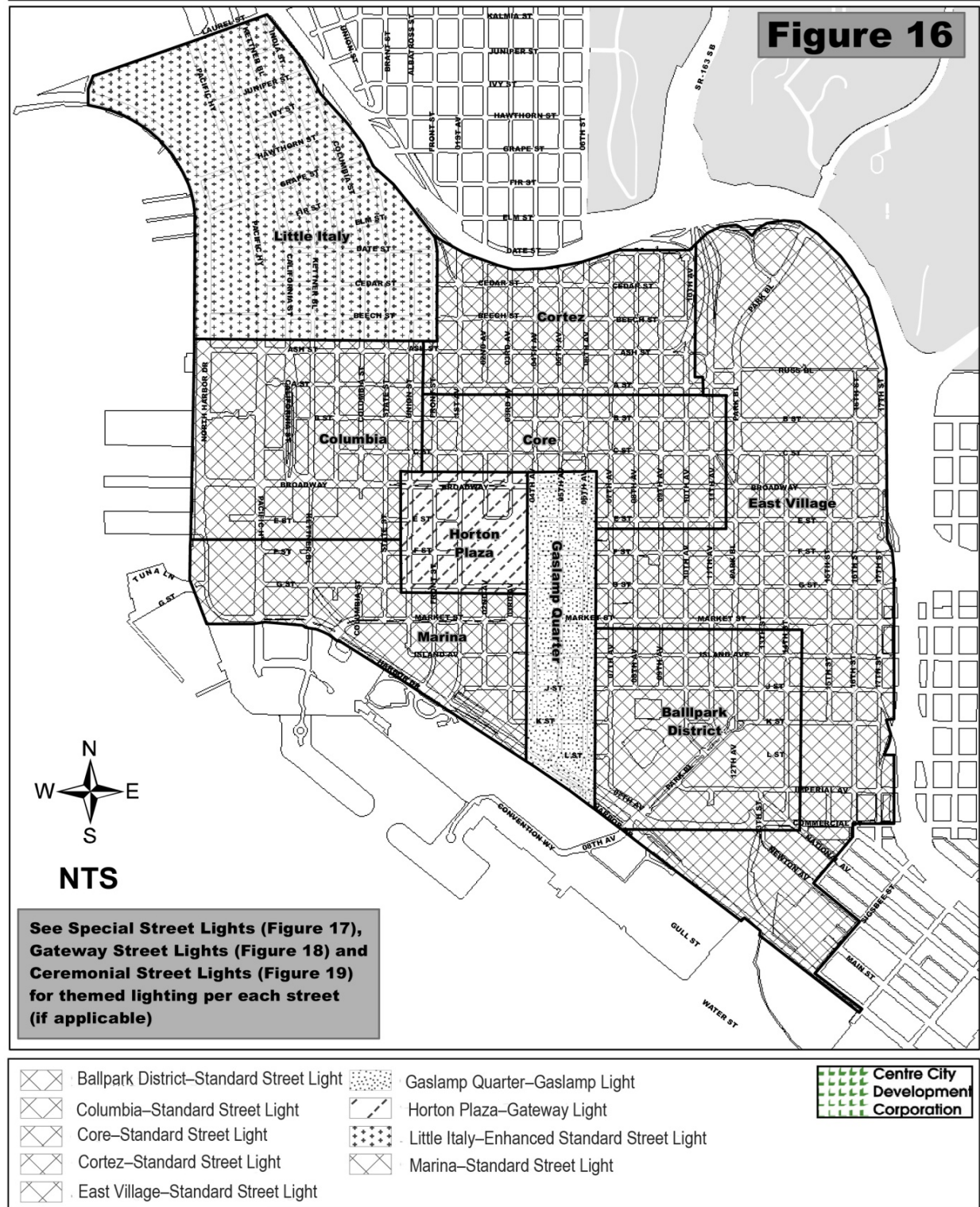

Figure 16: District Street Lights

# REVISED DRAFT

This Document is a draft pending final approval. Please contact a CDCD Planner at (619) 235-2200 to discuss your project.

## SPECIAL STREET LIGHTS

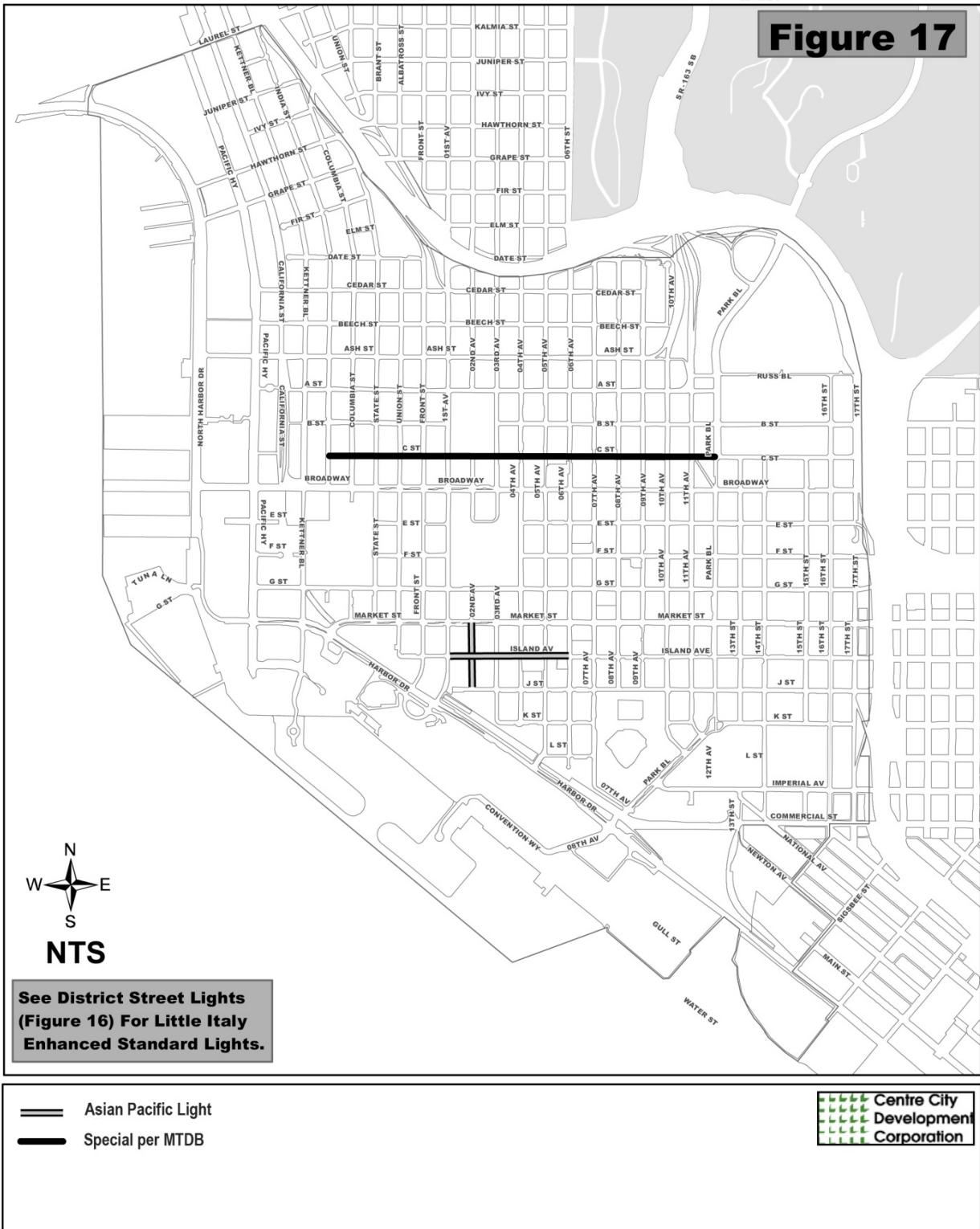

Figure 17: Special Street Lights

# REVISED DRAFT

This Document is a draft pending final approval. Please contact a CCDC Planner at (619) 235-2200 to discuss your project.

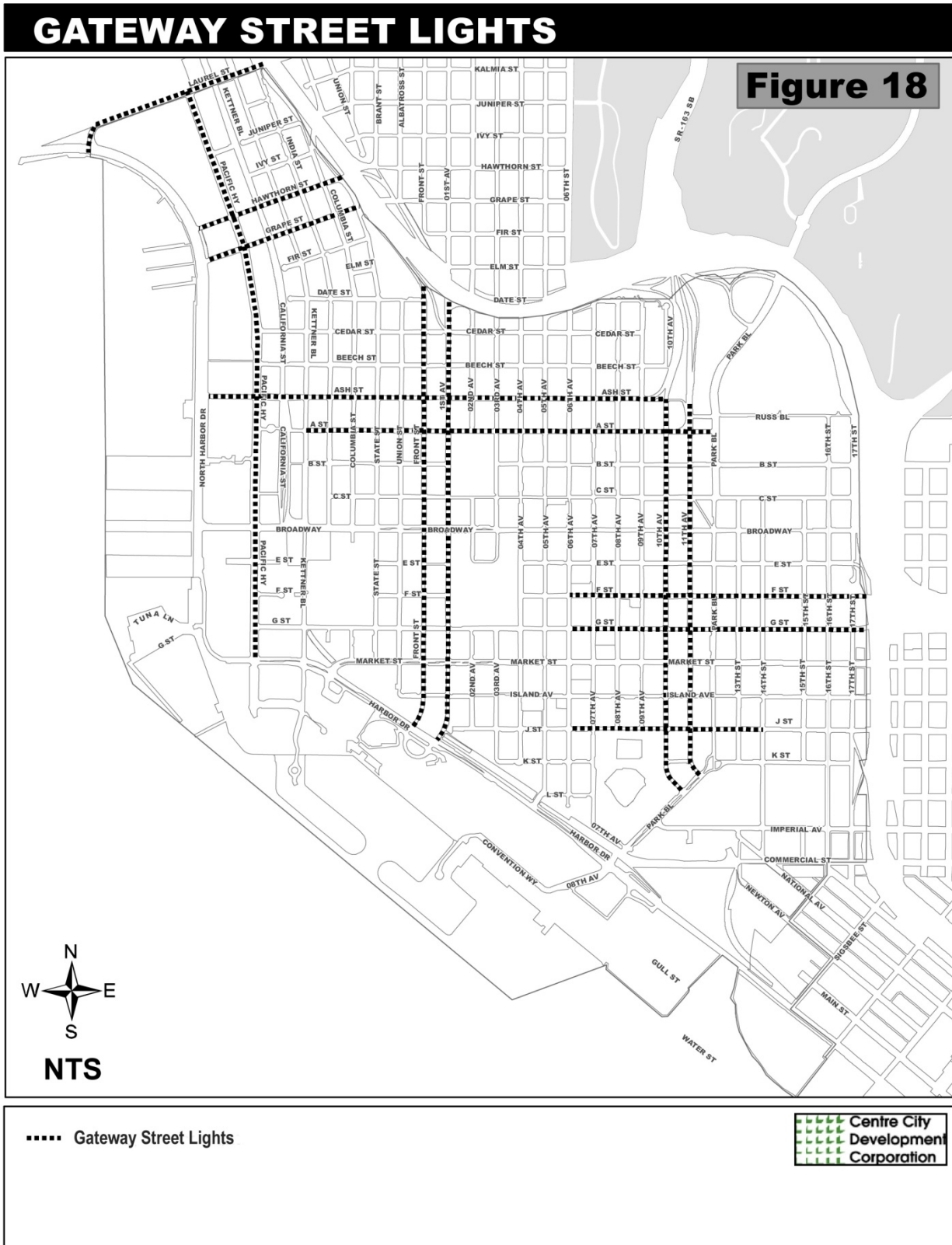

Figure 18: Gateway Street Lights



# REVISED DRAFT

This Document is a draft pending final approval. Please contact a CCDC Planner at (619) 235-2200 to discuss your project.

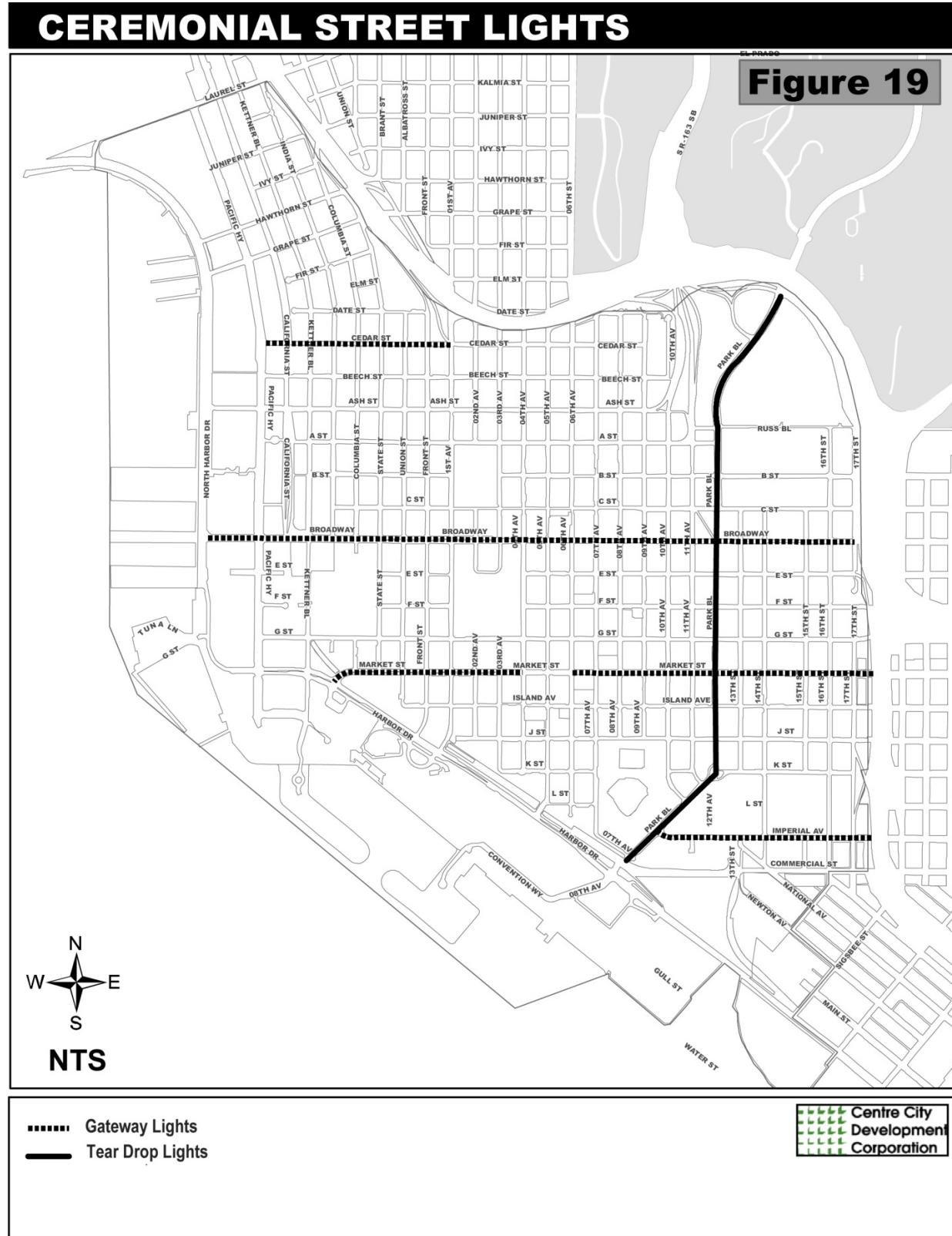

Figure 19: Ceremonial Street Lights

# REVISED DRAFT

This Document is a draft pending final approval. Please contact a CCDC Planner @ (619) 235-2200 to discuss your project.

## VI. TECHNICAL APPENDIX

This Appendix is not a part of the adopted Manual. It is for reference only and may be updated by CCDC without requiring the Manual to be officially amended.

### SIDEWALK PAVING

All projects involving sidewalk and curb and gutter work that require streetwork per the City's "Schedule J" shall include Street Typical Section.

#### *Asian Pacific Paving*

The Asian Pacific Paving shall be a brick sidewalk consisting of CCDC Brick Paving with 'Ironspot' finish and random tile insets. The tile insets shall be coarse textured, **eight (8) inches** by **eight (8) inches** by Arizona Tile- Sangria, Dusk Sky, and Spruce. The tiles shall be cut to **seven and five-eighths (7<sup>5</sup>/<sub>8</sub>) inches** by **seven and five-eighths (7<sup>5</sup>/<sub>8</sub>) inches** to fit between the bricks. **Nine (9) tiles, three (3) of each color**, shall be installed for every one hundred (100) square feet of brick (Figure T-1).

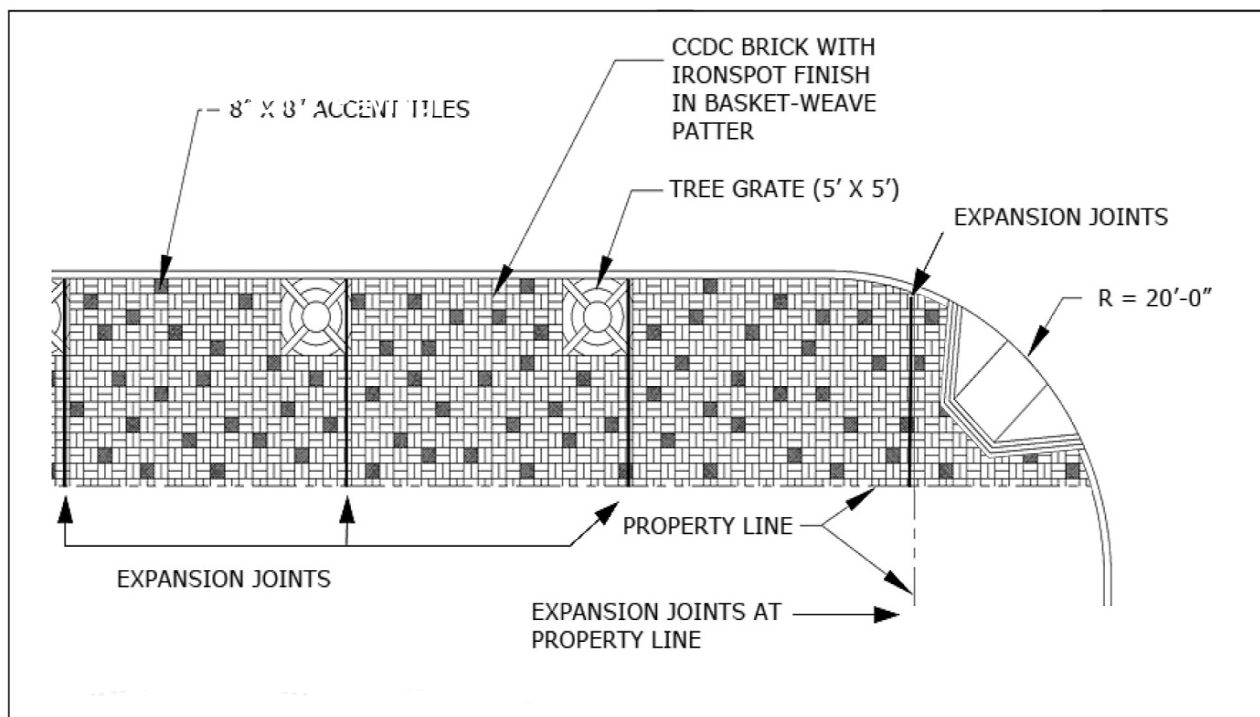

FigureT-1: Asian Pacific Paving

# REVISED DRAFT

This Document is a draft pending final approval. Please contact a CCDC Planner @ (619) 235-2200 to discuss your project.

## Ballpark District Paving

The Ballpark District Paving shall be a concrete sidewalk with scorelines creating a **five (5) foot by five (5) foot** grid pattern with a **three-eighths (3/8) inch** Carroll Canyon exposed aggregate from KRC Rock or approved equal. The aggregate shall be integrally mixed into the concrete at the concrete batch plant, covered with plastic sheeting for approximately **twelve (12) hours**, and washed with clean water to remove cement between the aggregate in a uniform manner to a depth of approximately **one-sixteenth (1/16) of an inch** (Figure T-2). See the Construction Detail Appendix for concrete paving installation.

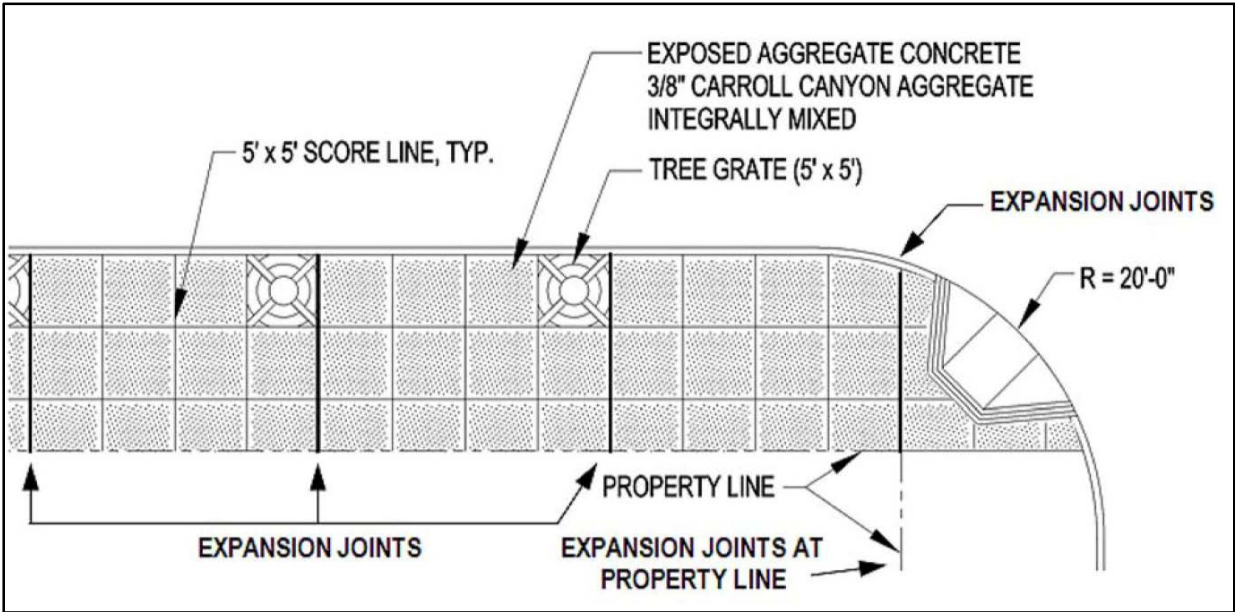

Figure T-2: Ballpark District Paving

# REVISED DRAFT

This Document is a draft pending final approval. Please contact a CCDC Planner @ (619) 235-2200 to discuss your project.

## Broadway Paving

The Broadway Paving shall be a brick sidewalk consisting of CCDC Brick Paving and black accent brick. The black brick shall comply with ASTM C216, Type FXB and shall be **seven and five-eighths (7<sup>5</sup>/<sub>8</sub>) inches by three and five-eighths (3<sup>5</sup>/<sub>8</sub>) inches by one and a quarter (1<sup>1</sup>/<sub>4</sub>) inches** in size, 'Manganese Ironspot' color, wire-cut texture, by Endicott Clay Products Company or approved equal, shall conform to coefficient of friction SE871, and shall exceed the minimum requirements set by ASTM C216.75A for severe weather. The black brick shall be used in a single soldier course along the curb and gutter, around tree grates, and around pedestrian ramps. A double soldier course band shall be located approximately every **ten (10) feet** and at the property line near street corners. A single or double soldier course should be used as necessary at the property line to accommodate building pop-outs or entries. CCDC Brick shall be used in a single running bond course adjacent to the black bands, in a pin-wheel pattern with a half-size black brick in the center, and in a herringbone pattern between the bands (Figure T-3).

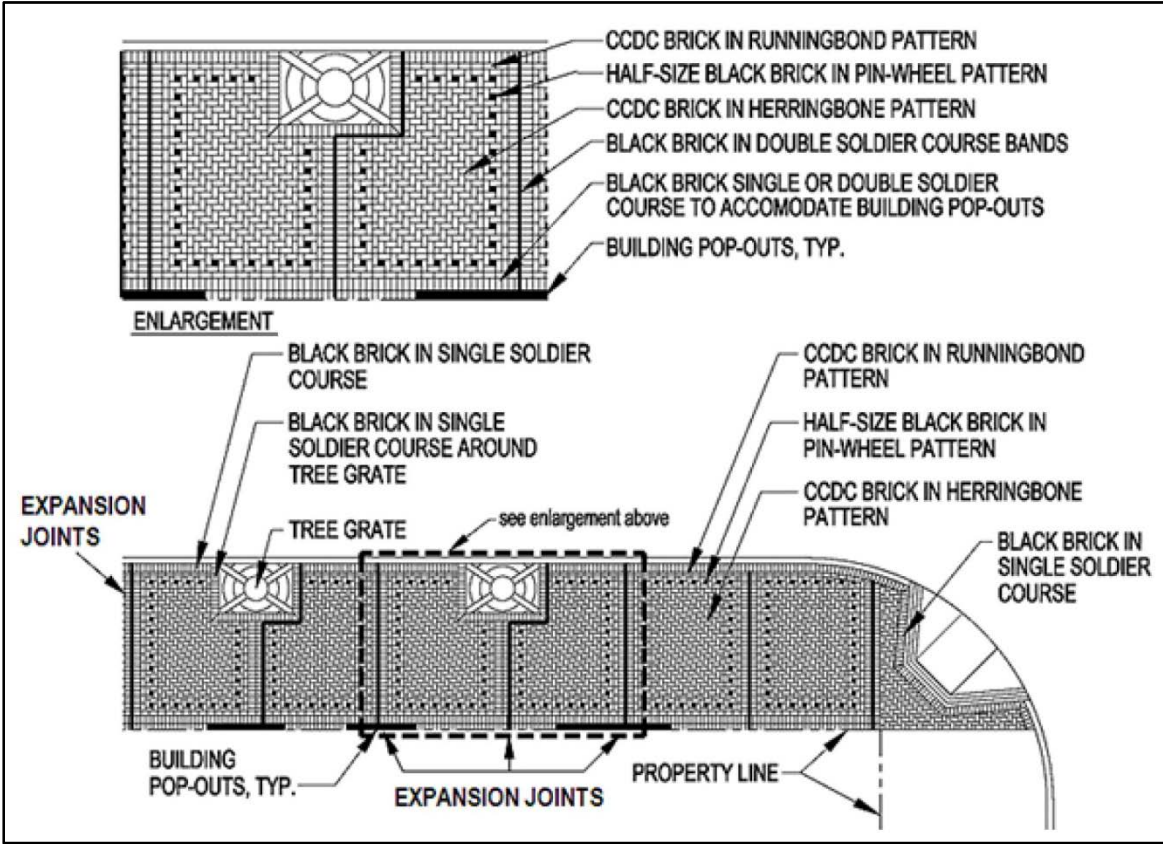

Figure T-3: Broadway Paving

# REVISED DRAFT

This Document is a draft pending final approval. Please contact a CCDC Planner @ (619) 235-2200 to discuss your project.

## CCDC Standard Paving

CCDC Standard Paving shall be a concrete sidewalk with scorelines creating either a **four (4) foot by four (4) foot** or a **five (5) foot by five (5) foot** grid pattern. Inside of each scoreline shall be a **four-inch** smooth shiner band. The concrete field surface shall be a medium broom finish, brushed perpendicular to curb. The concrete shall be integrally colored French Gray (C-14) by Scofield, Solomon "Old Gray," Davis "Light Gray" or approved equal (Figure T-4 and Figure T-5). See the Construction Detail Appendix for concrete paving installation.

Additional materials, such as granite pavers, brick, or ceramic tiles shall not be incorporated into the Standard CCDC Sidewalk paving. Concrete surface treatments, such as exposed aggregate, sandblasting, stamping, etc. shall not be allowed.

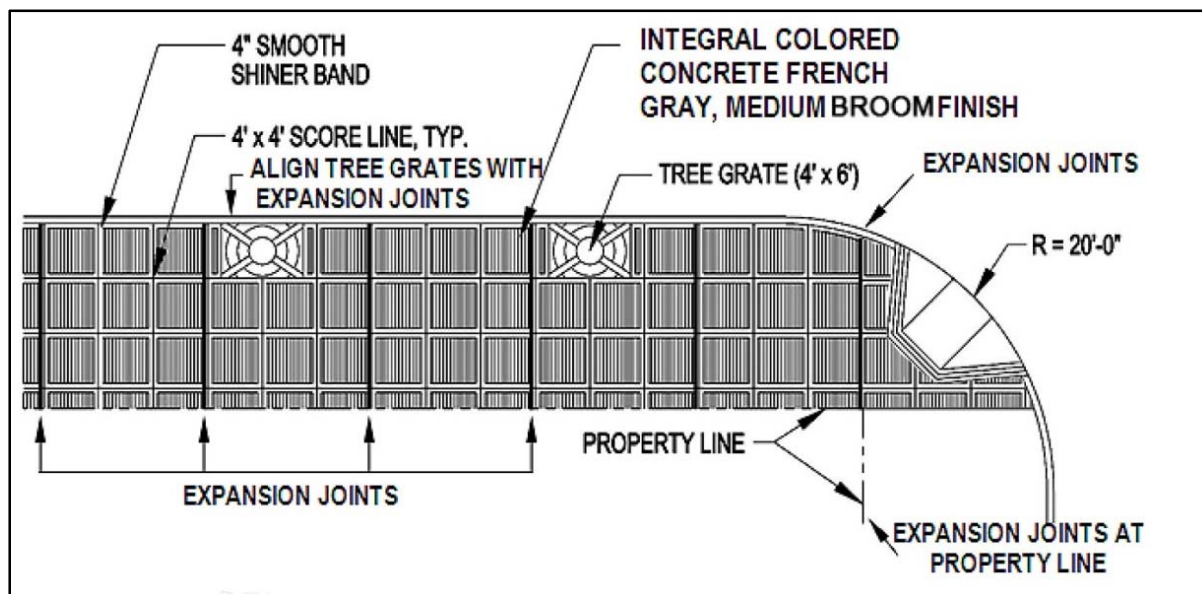

Figure T-4: CCDC Standard Paving with 4'x4' Grid

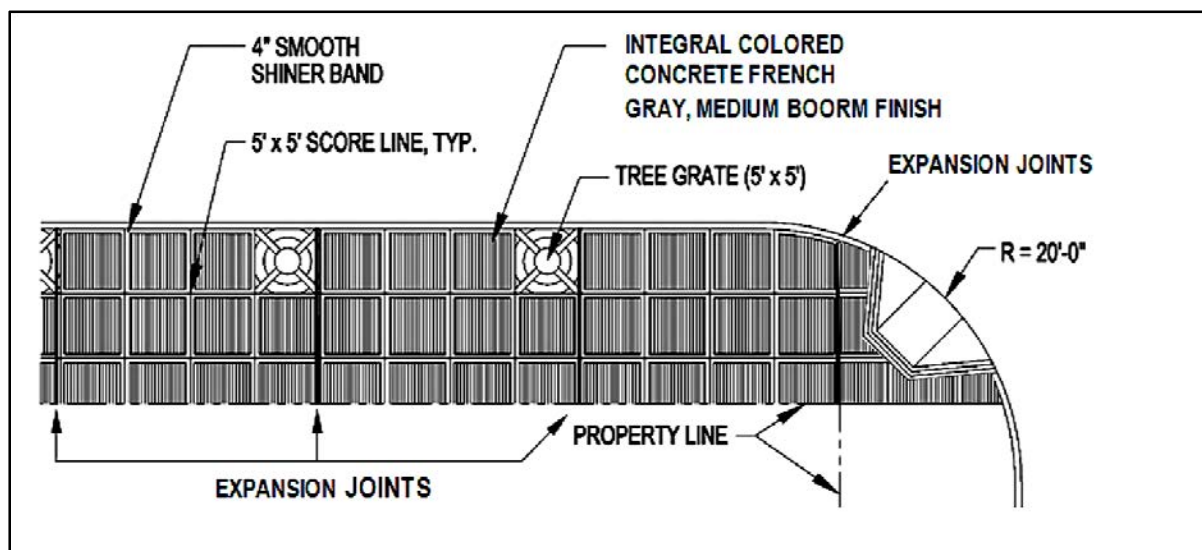

Figure T-5: CCDC Standard Paving with 5'x5' Grid



# REVISED DRAFT

This Document is a draft pending final approval. Please contact a CCDC Planner @ (619) 235-2200 to discuss your project.

## CCDC Brick Paving

The CCDC Brick Paving shall be a brick sidewalk. The brick shall comply with ASTM C216, Type FXB and shall be **seven and five-eighths (7<sup>5</sup>/<sub>8</sub>) inches by three and five-eighths (3<sup>5</sup>/<sub>8</sub>) inches by one and a quarter (1<sup>1</sup>/<sub>4</sub>) inches** in size, 'Rose Blend' color, wire cut texture, by Endicott Clay Products Company(619.977.5955), Pacific Clay (619)674-2131) or approved equal, shall conform to coefficient of friction SE871, and shall exceed the minimum requirements set by ASTM C216.75A for severe weather. Driveway Bricks shall be two and one quarter (2<sup>1</sup>/<sub>4</sub>" ) **thick**. Full size samples shall be provided to the Resident Engineer for approval prior to construction. The brick design for street corners should be in a herringbone pattern per the Brick Paving at Pedestrian Ramps detail in the Construction Detail Appendix.

CCDC Brick Paving shall be installed on a concrete base on a mortar bed, per the details shown in the Construction Detail Appendix. Expansion joints for the concrete base shall be located a maximum of **forty-five (45) feet** apart and shall have a grout joint between the brick pavers.

Grout shall meet or exceed ANSI A118.6 and CTI 85-8 latex Portland cement grout. Grout shall have a compressive strength of **3000 PSI** in **seven (7) days** and a water absorption rate of **five percent (5%)**. Grout shall be colored French Gray (C-14) by Scofield or approved equal and shall be a minimum of **three-eighths (3<sup>8</sup>/<sub>8</sub>) of an inch** in width and a maximum of **seven-sixteenths (7/16) of an inch**.

## Children's Park Paving

The Children's Park Paving shall be alternating, dark and light, **four (4) foot** bands of integrally colored concrete, running perpendicular to the curb, with the Children's Park Tree Grate. The dark color shall be Dark Gray (C-34) by Scofield or approved equal, with a medium broom finish running perpendicular to the curb and the light color shall be naturally colored concrete with a medium broom finish running perpendicular to the curb (Figure T-6).

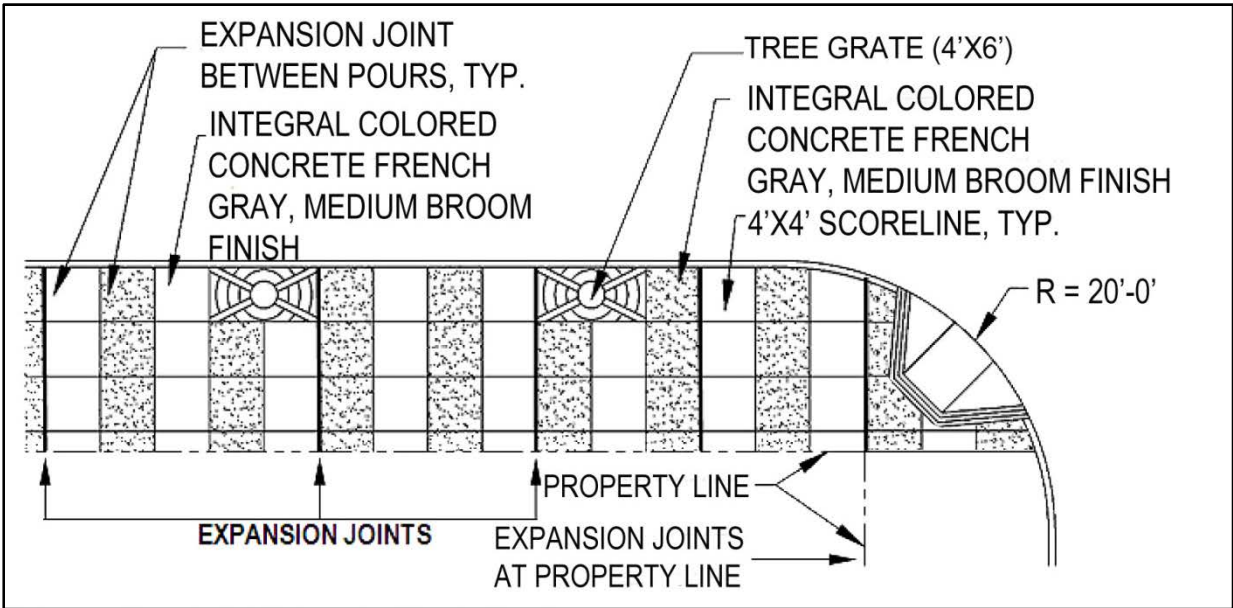

Figure T-6: Children's Park Paving

# REVISED DRAFT

This Document is a draft pending final approval. Please contact a CCDC Planner @ (619) 235-2200 to discuss your project.

## Gaslamp Quarter Paving

The Gaslamp Quarter paving shall be various patterns of CCDC brick paving. The paving patterns shall change every twenty-five to fifty feet (25-50') and shall be separated by a four foot (4") wide concrete band, integrally colored French Gray (C-14) by Scofield or approved equal. Final decisions regarding locations of pattern changes shall be made by CCDC. Some of the existing brick patterns in downtown are basket weave, herringbone, running bond and variations based on these designs (Figure T-7, Figure T-8 and Figure T-9).

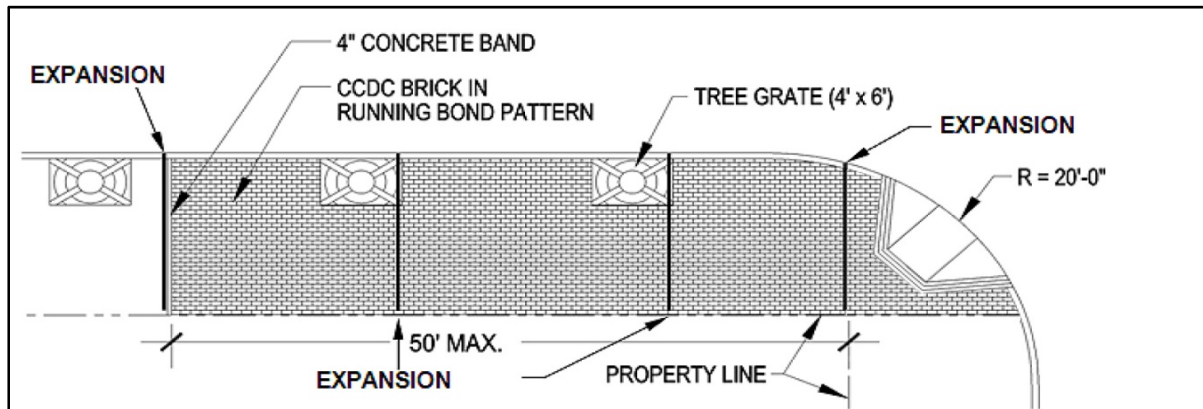

**Figure T-7: Gaslamp Quarter Paving–Basket Weave Pattern**

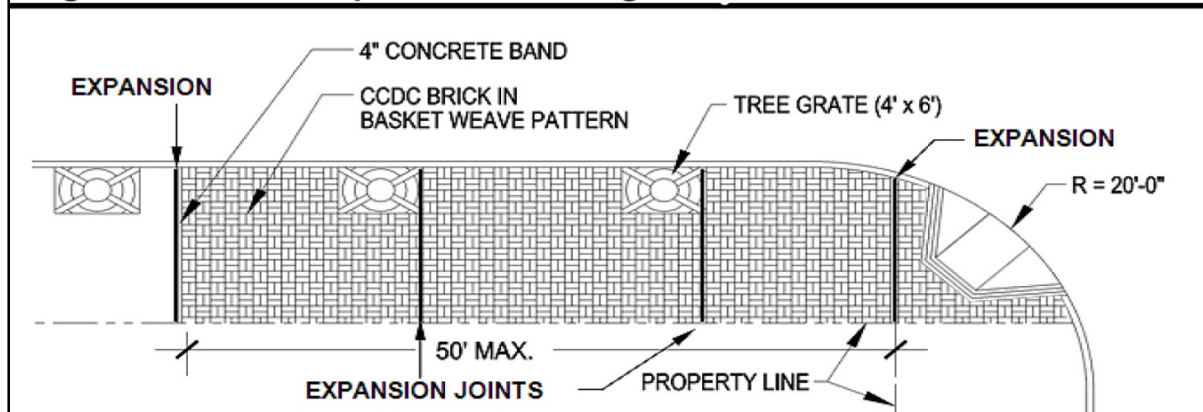

**Figure T-8: Gaslamp Quarter Paving–Running Bond Pattern**

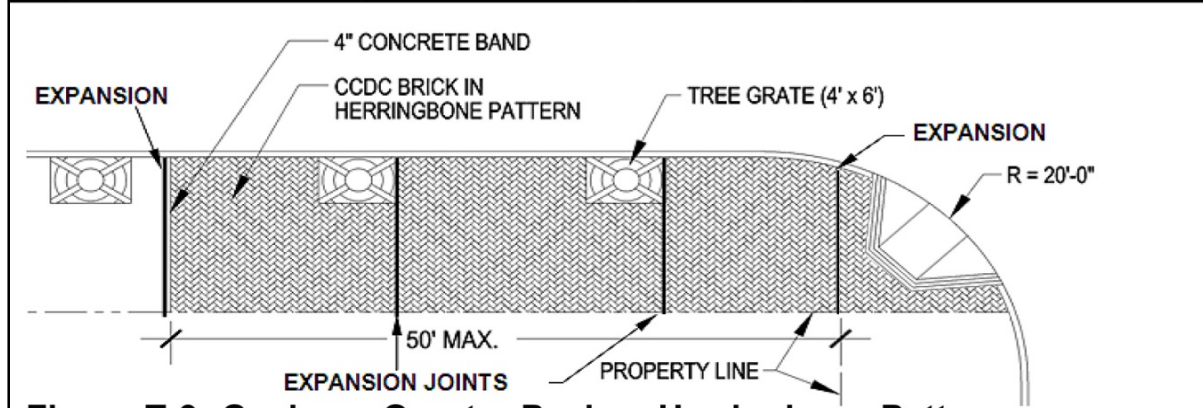

**Figure T-9: Gaslamp Quarter Paving–Herringbone Pattern**

# REVISED DRAFT

This Document is a draft pending final approval. Please contact a CCDC Planner @ (619) 235-2200 to discuss your project.

## Gateway Paving

The Gateway Paving shall be an upgraded concrete sidewalk that is approved by CCDC on a case-by-case basis. Concrete surface treatments, such as exposed aggregate, sandblasting, circular broom finishing, etc. must be used to upgrade the sidewalk to make it sufficiently different from the Standard CCDC Paving. Additional materials, such as granite pavers, brick or ceramic tiles, may also be incorporated in the paving when it helps enhance the surrounding architecture. Stamped concrete surfaces shall not be allowed.

## Horton Plaza

Horton Plaza Paving to be used in Horton Plaza Neighborhood, directly adjacent to Horton Plaza only (Figure A-7).

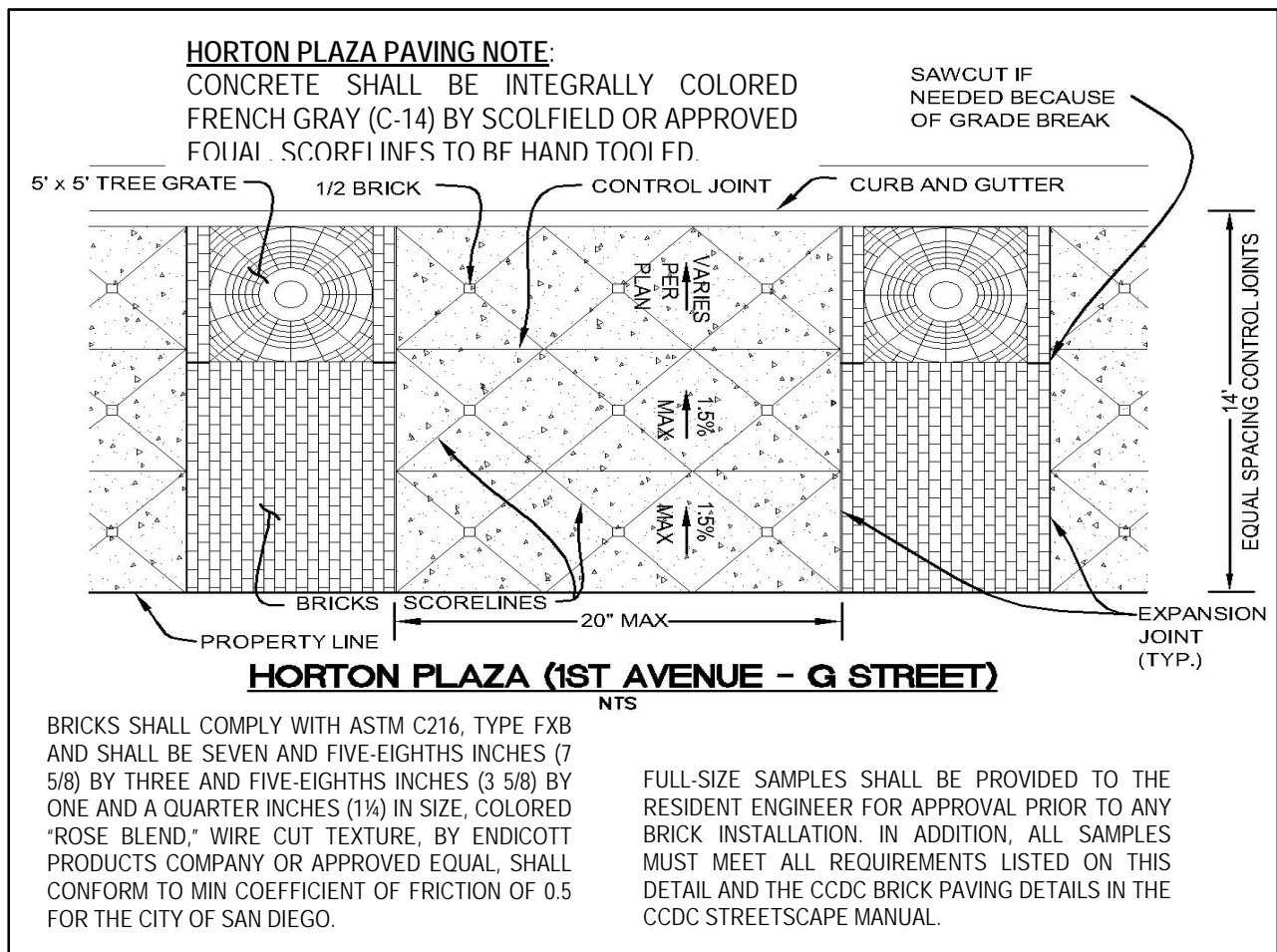

Figure T-10: Horton Plaza Paving



# REVISED DRAFT

This Document is a draft pending final approval. Please contact a CCDC Planner @ (619) 235-2200 to discuss your project.

## *Island Avenue Paving* – east of 6th Avenue only

The Island Avenue Paving shall be a concrete sidewalk with scorelines creating a two (2) foot by two (2) foot grid, with **three-eighths (3/8) inch** 'Carroll Canyon' exposed aggregate from KRC Rock or approved equal, and CCDC Brick Paving used to create double-soldier course bands and trim course. The concrete does not require the use of integral color. The aggregate shall be integrally mixed into the concrete at the concrete batch plant, treated with a surface retardant and power-washed within 24 hours to expose the aggregate. Street corners shall be CCDC Brick Paving in a herringbone pattern (Figure T-11). See the Construction Detail Appendix for concrete paving and brick paving installation.

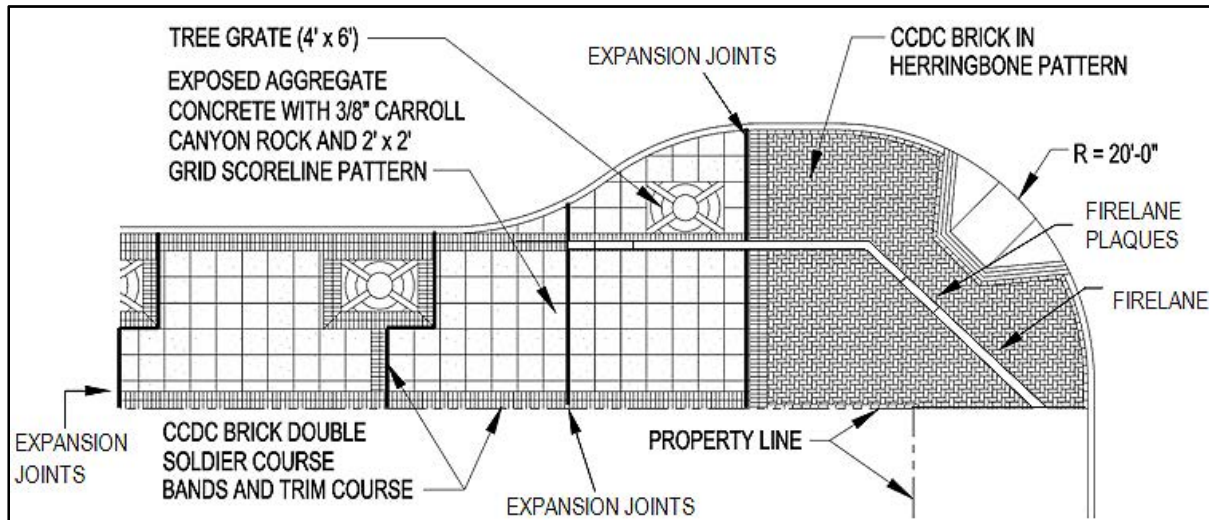

Figure T-11: Island Avenue Paving

## *Little Italy Paving*

The Little Italy Paving shall be a concrete sidewalk with scorelines creating a two (2) foot by two (2) foot grid, integrally colored French Gray (C-14) by Scofield or approved equal, and a medium broom finish with a light pressure wash (Figure T-12). See the Construction Detail Appendix for concrete paving installation.

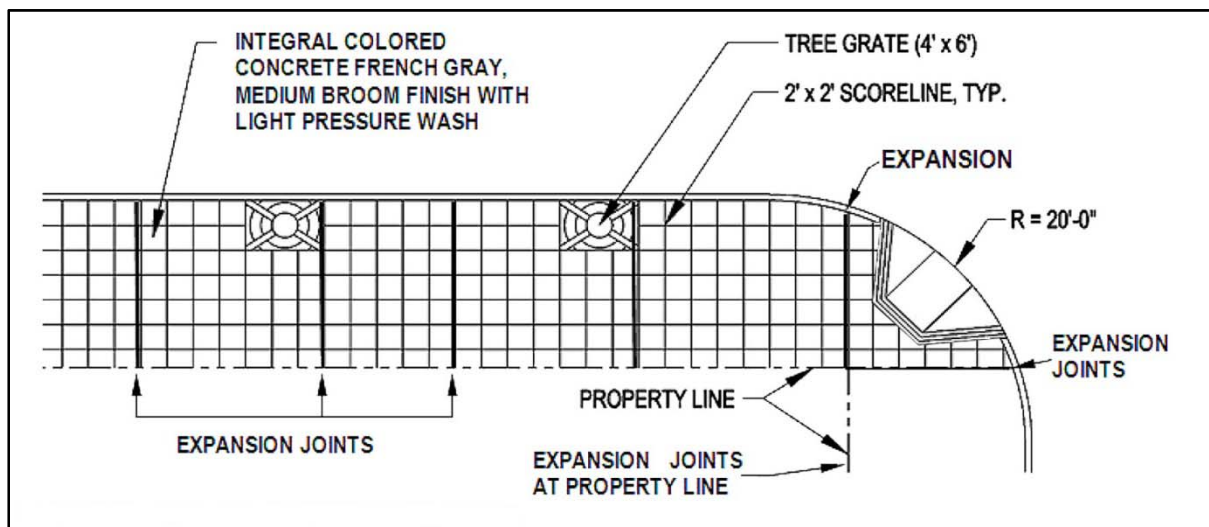

Figure T-12: Little Italy Paving

# REVISED DRAFT

This Document is a draft pending final approval. Please contact a CCDC Planner @ (619) 235-2200 to discuss your project.

## *Marina Paving*

The Marina Paving shall be a six (6) inch by twelve (12) inch by eighty (80) millimeter solid, interlocking, concrete paver, 'Antique Red' color, by Ackerstone or approved equal. The paver should be laid in a herringbone pattern ninety (90) degrees to the curb although some differentiation in pattern may be permitted. See the Construction Detail Appendix and Specification Appendix for standard interlocking paver installation.

## *Market Street Paving*

The Market Street Paving shall be a concrete sidewalk, integrally colored French Gray (C-14) by Scofield or approved equal, with **three-eighths (3/8) inch** 'Carroll Canyon' exposed aggregate from KRC Rock or approved equal, and CCDC Brick Paving used to create triple soldier course bands and quadruple soldier course trim course (Figure T-13). The concrete does not require the use of integral color. The aggregate shall be integrally mixed into the concrete at the concrete batch plant, treated with a surface retardant, and power-washed within 24 hours to expose the aggregate. See the Construction Detail Appendix for standard concrete paving and brick paving installation.

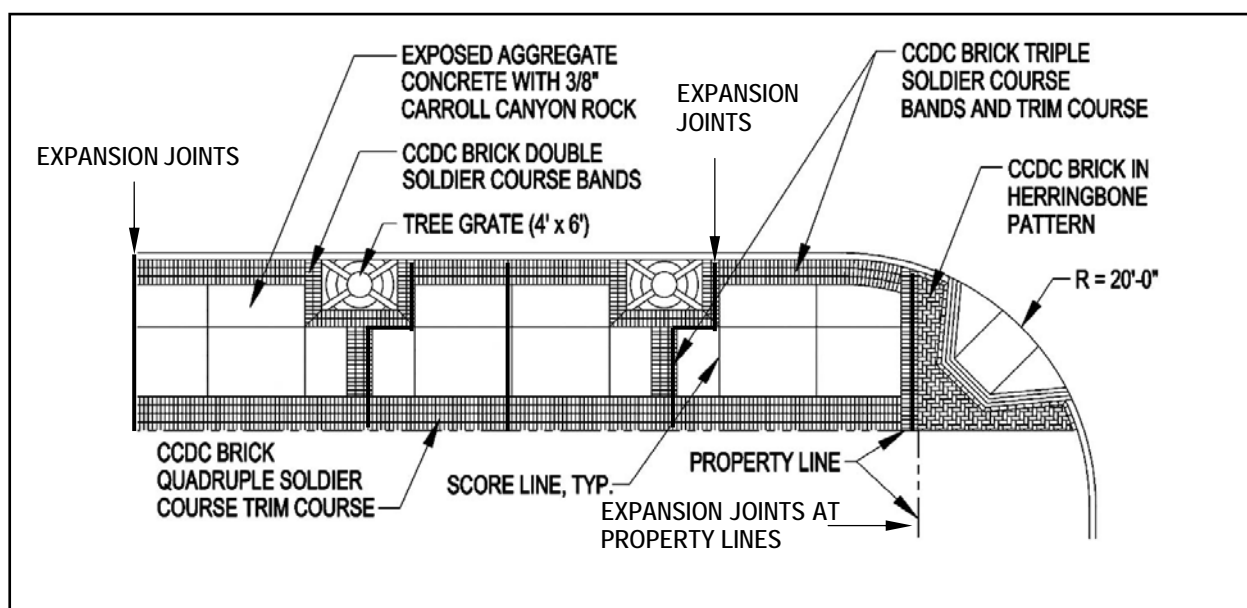

Figure T-13: Market Street Paving

# REVISED DRAFT

This Document is a draft pending final approval. Please contact a CCDC Planner @ (619) 235-2200 to discuss your project.

## *Pacific Highway Paving*

The Pacific Highway Paving shall be a natural gray concrete sidewalk, with **one-quarter to one-half (¼-½) inch** Arizona River Rock exposed aggregate from KRC Rock or approved equal, and interlocking paver decorative bands, trimcourse, and **six (6) foot by six (6) foot** square inserts. The interlocking pavers shall be **six (6) inch by twelve (12) inch by eighty (80) millimeters** solid, interlocking, concrete paver, color 'Antique Red' by Ackerstone or approved equal (Figure T-14).

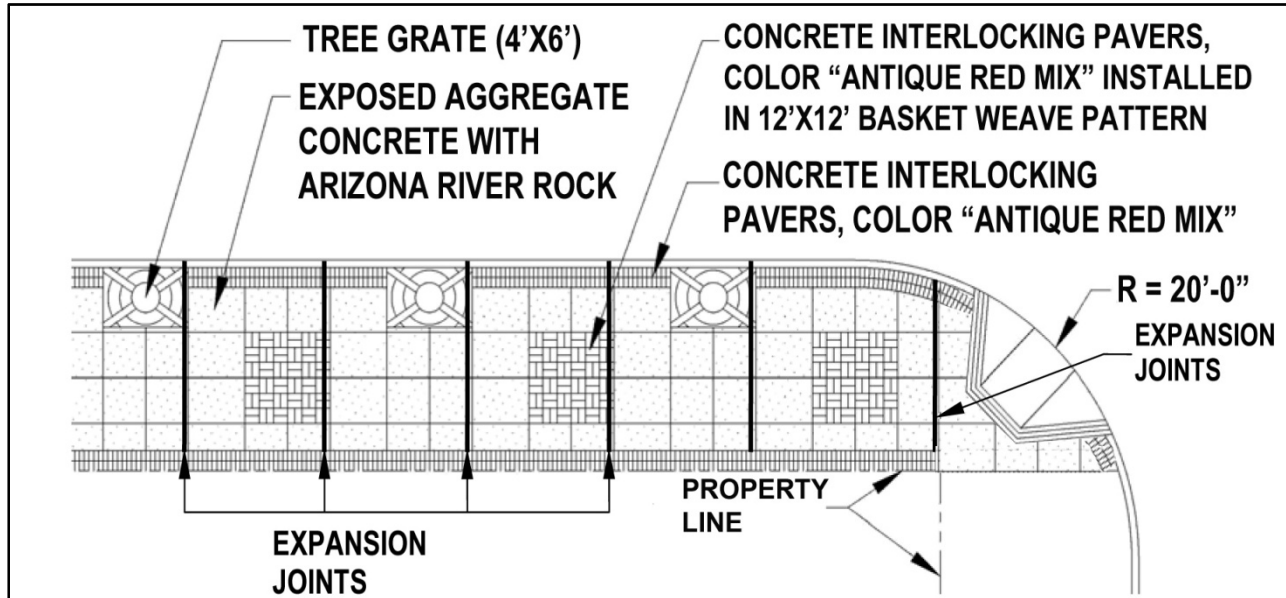

Figure T-14: Pacific Highway Paving

## *Terra Cotta Tile Paving*

Terra Cotta Paving will be specified to match existing pavers on C Street west of Park Boulevard.

# REVISED DRAFT

This Document is a draft pending final approval. Please contact a CCDC Planner @ (619) 235-2200 to discuss your project.

## Park-to-Bay Paving

The Park-to-Bay Paving shall be a concrete sidewalk, integrally colored with French Gray (C-14) by Scofield or approved equal, with **eight (8) foot wide bands of three-eighths (3/8) inch 'Carroll Canyon' exposed aggregate** from KRC Rock or approved equal, and two **eight (8) inch wide concrete pavers shall be eight (8) inches by eight (8) inches** in size, divided diagonally in half with alternating colors to create a zigzag color pattern. Blue colors shall be pointed south (towards the Bay) and Green colors shall be pointed north (towards Balboa Park) (Figure T-14 and Figure T-15).

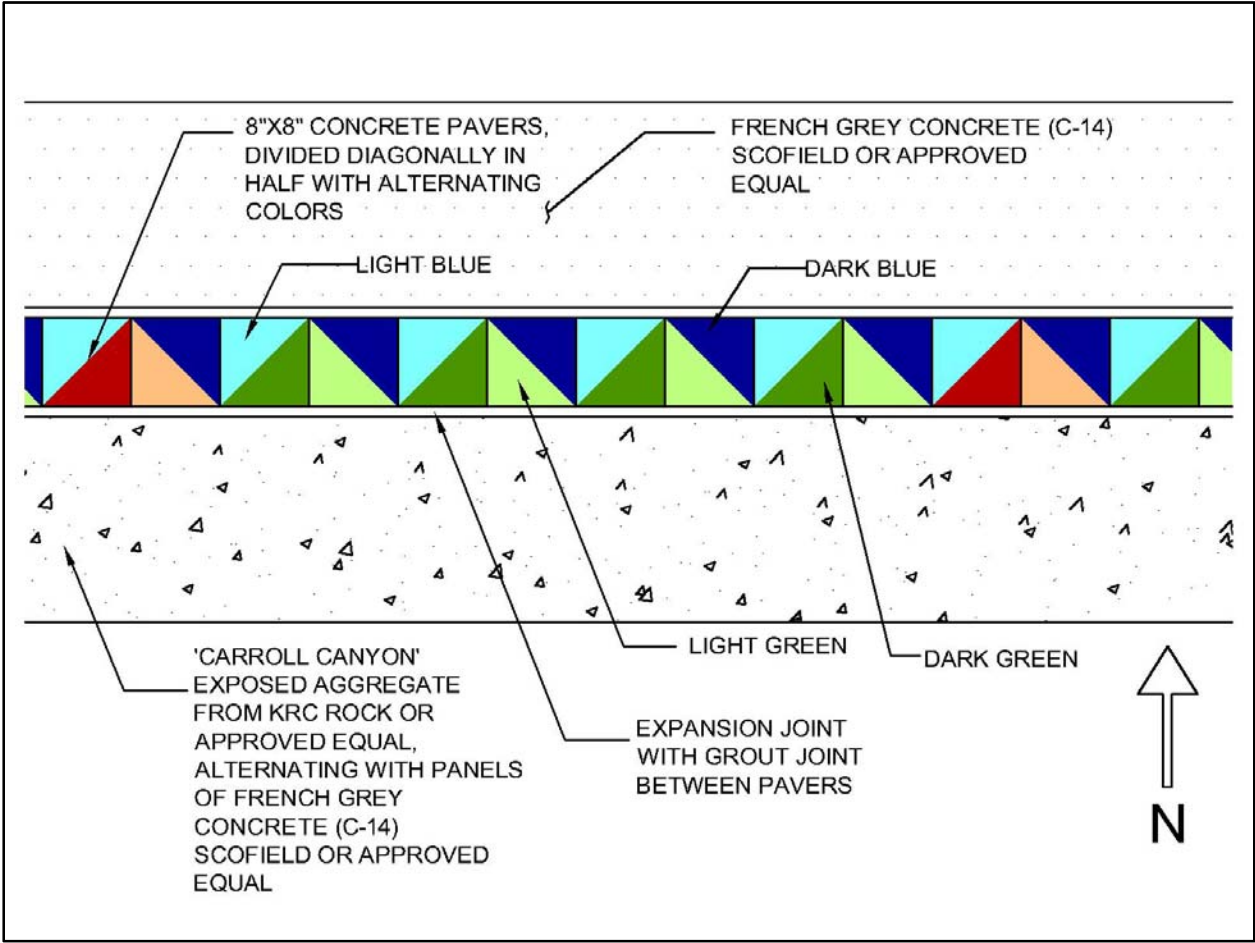

Figure T-15: Park-to-Bay Paving

# REVISED DRAFT

This Document is a draft pending final approval. Please contact a CCDC Planner @ (619) 235-2200 to discuss your project.

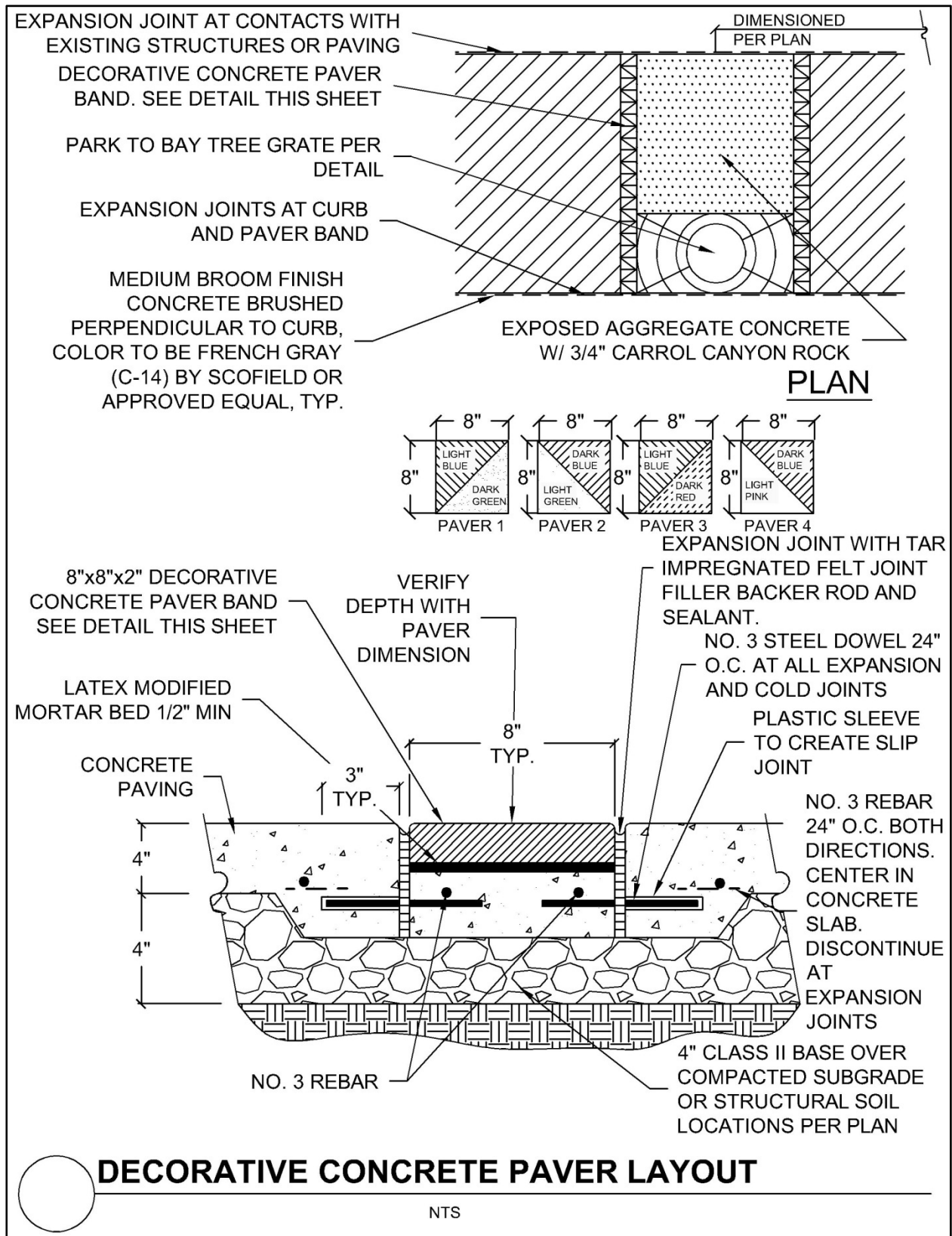

Figure T-16: Park-to-Bay Paver (Layout)



# REVISED DRAFT

This Document is a draft pending final approval. Please contact a CCDC Planner @ (619) 235-2200 to discuss your project.

## TREE GRATES

### General Notes:

All Tree Grates shall have factory-applied finishes, consisting of a minimum of one coat primer and one coat black enamel. Top finish shall be a slip-resistant coating such as 'SharkGrip' by Sherwin Williams or approved equal. When applied following manufacturer's instructions, the slip-resistant coating shall provide a minimum static coefficient of 0.6 or the minimum recommendation for compliance with California Title 24 or the ADAAG requirements, whichever is most stringent. The tree grate shall have a minimum uniform live load of 250 pounds per square foot in sidewalks, and have a method of symmetrical interior expandable rings/openings.

### *CCDC Standard Tree Grate—Four (4) Foot by Six (6) Foot Size*

The CCDC Standard Tree Grate—**four (4) foot by six (6) foot size**—shall be the Starburst Series 2, **three-eighths (3/8) inch** slots, model number M7222-2, **forty-eight (48) inches by seventy-two (72) inches**, two pieces, with one-piece steel frame unit, factory primed and painted black, by Ironsmith or approved equal (Figure T-17).

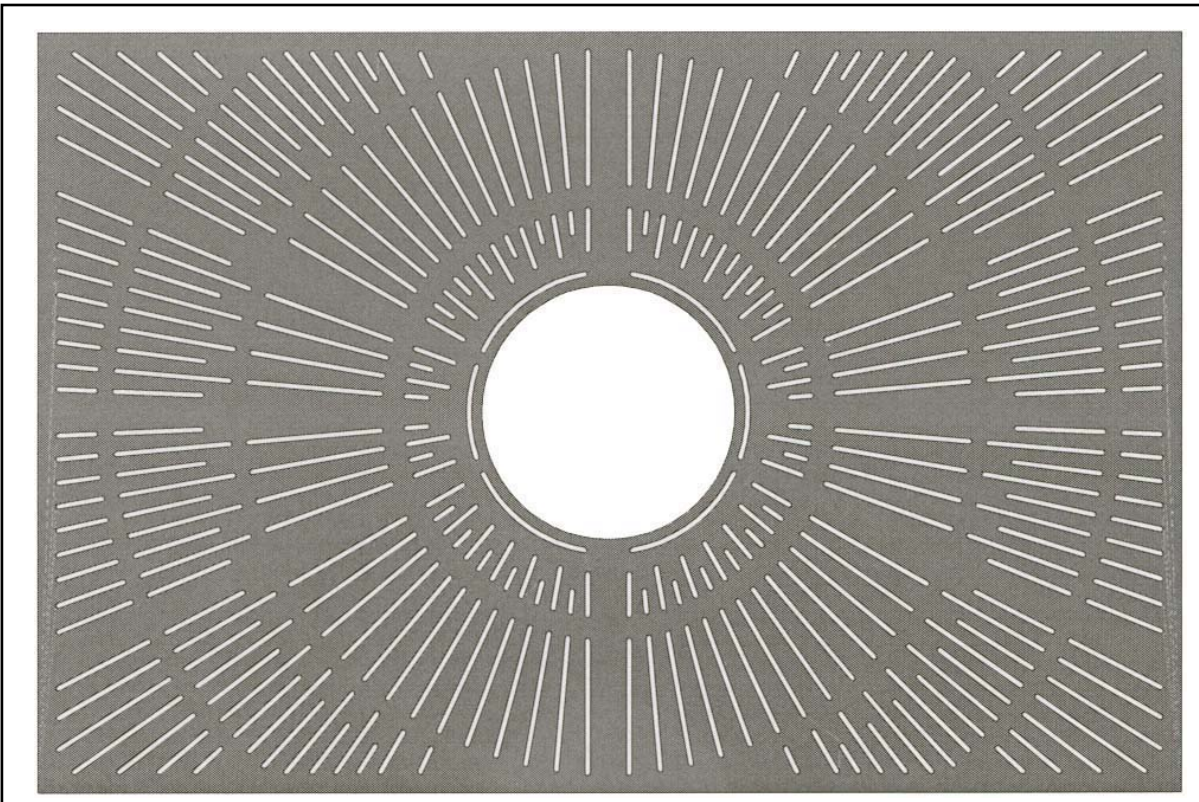

Figure T-17: CCDC Standard Tree Grate—Four (4) foot by six (6) foot size

# REVISED DRAFT

This Document is a draft pending final approval. Please contact a CCDC Planner @ (619) 235-2200 to discuss your project.

*CCDC Standard Tree Grate*—Five (5) Foot by Five (5) Foot Size

The **CCDC Standard Tree Grate**—five (5) foot by five (5) foot size—**shall be the Starburst Series 2**, three-eighths ( $\frac{3}{8}$ ) inch slots, model number M6018, two pieces, with one-piece steel frame unit, factory primed and painted black, by Ironsmith or approved equal (Figure T-18).

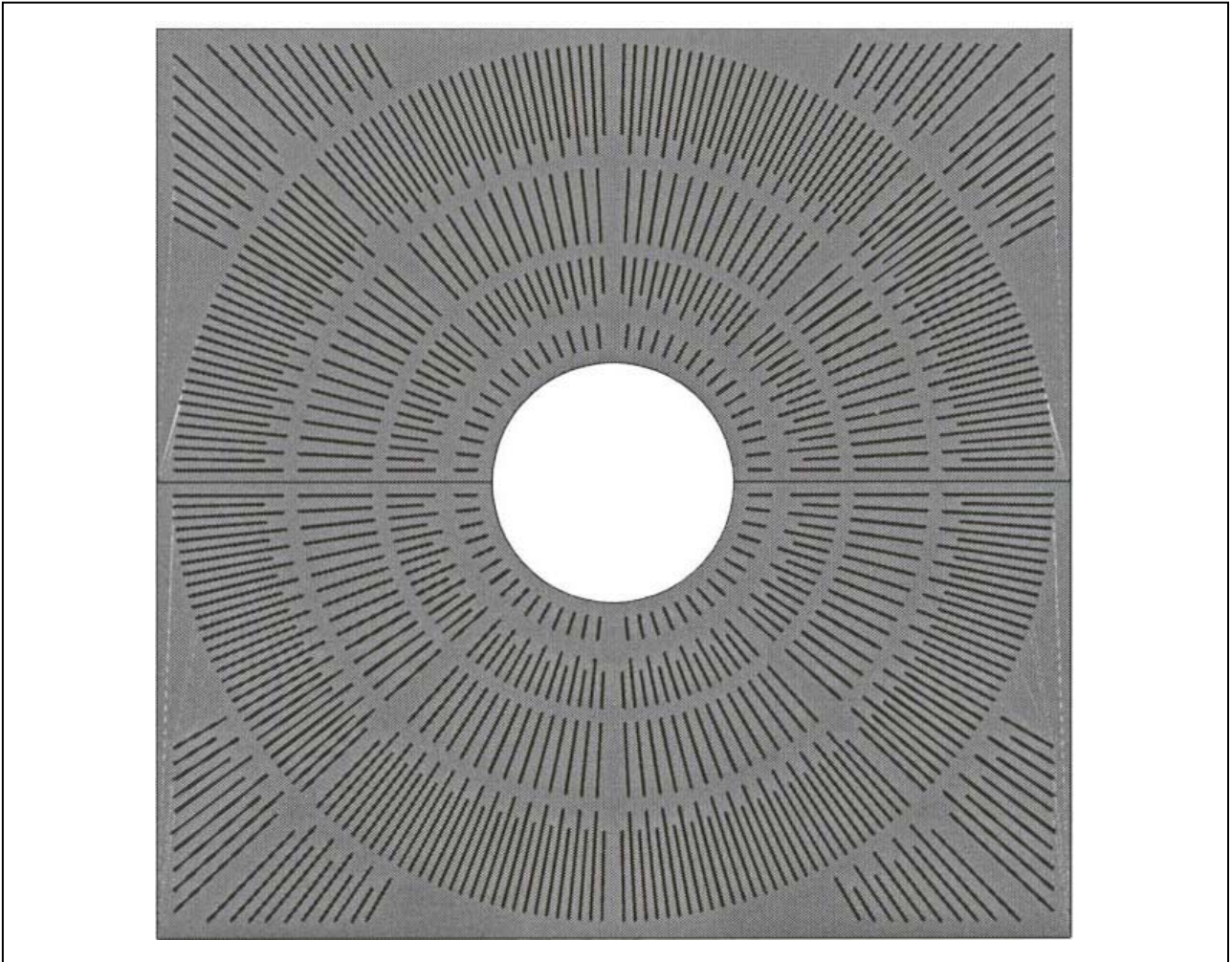

Figure T-18: CCDC Standard Tree Grate—Five (5) Foot by Five (5) Foot Size



# REVISED DRAFT

This Document is a draft pending final approval. Please contact a CCDC Planner @ (619) 235-2200 to discuss your project.

## *Special and Gateway Tree Grate*—Four (4) Foot by Six (6) Foot Size

The Special Tree and Gateway Tree Grate—**four (4) foot by six (6) foot** size—shall be model number R-8811 from the Boulevard Collection, two pieces, with one-piece steel frame unit, factory primed and painted black, by Neenah Foundry or approved equal (Figure T-19).

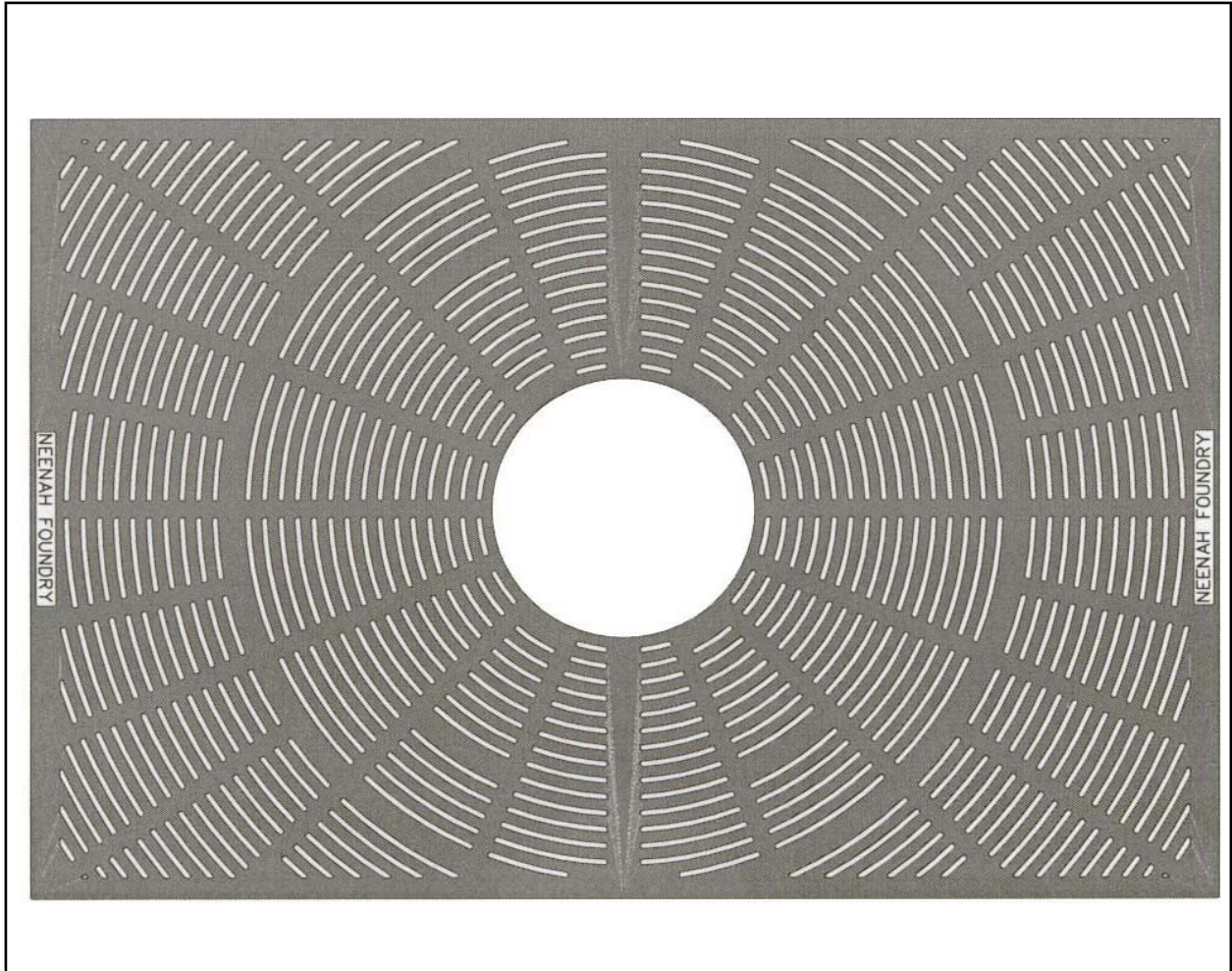

Figure T-19: Special and Gateway Tree Grate—Four (4) Foot by Six (6) Foot Size



# REVISED DRAFT

This Document is a draft pending final approval. Please contact a CCDC Planner @ (619) 235-2200 to discuss your project.

## *Special and Gateway Tree Grate*—Five (5) Foot by Five (5) Foot Size

The Special Tree and Gateway Tree Grate—**five (5) foot by five (5) foot size**—shall be model number R-8712 from the Avenue Collection, two pieces, with one-piece steel frame unit, factory primed and painted black, by Neenah Foundry or approved equal (Figure T-20).

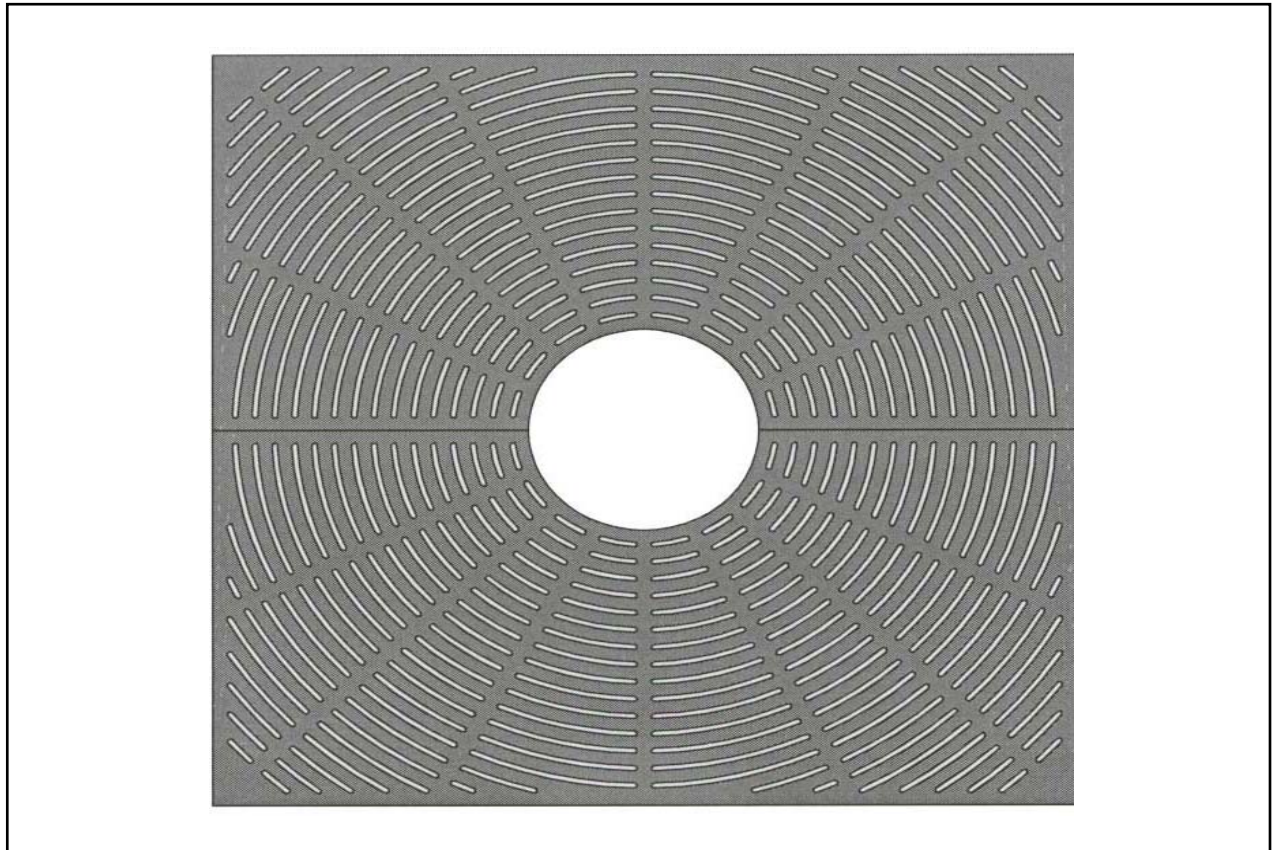

Figure T-20: Special and Gateway Tree Grate—Five (5) Foot by Five (5) Foot Size

# REVISED DRAFT

This Document is a draft pending final approval. Please contact a CCDC Planner @ (619) 235-2200 to discuss your project.

## *Ceremonial Tree Grate and Little Italy Tree Grate*

The Ceremonial Tree Grate shall be **four (4) foot** by **six (6) foot**, model Chinook 4x6 RCT, four pieces with one-piece steel frame, factory primed and painted black, by Urban Accessories or approved equal (Figure T-21).

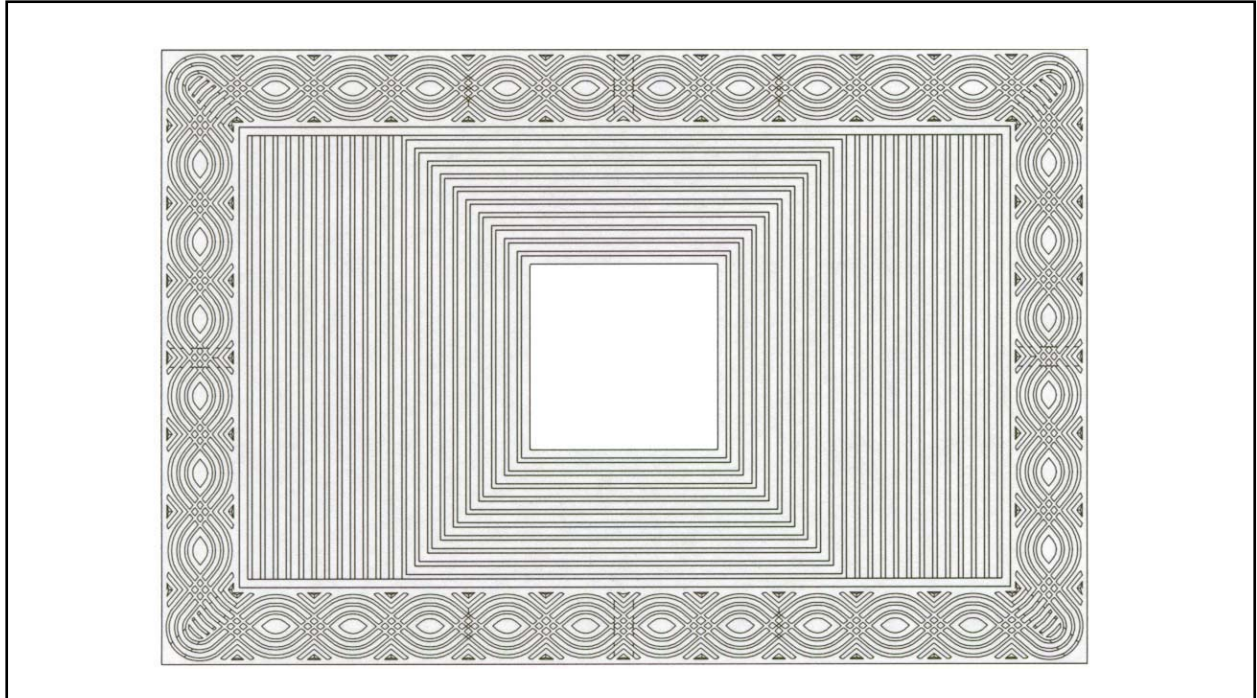

Figure T-21: Ceremonial Tree Grate and Little Italy Tree Grate

# REVISED DRAFT

This Document is a draft pending final approval. Please contact a CCDC Planner @ (619) 235-2200 to discuss your project.

## *Asian Pacific Tree Grate*

The Asian Pacific Tree Grate shall be **five (5) foot by five (5) foot**, model 5' SQ OT-T24, four pieces with one-piece steel frame, factory primed and painted black, by Urban Accessories or approved equal (Figure T-22).

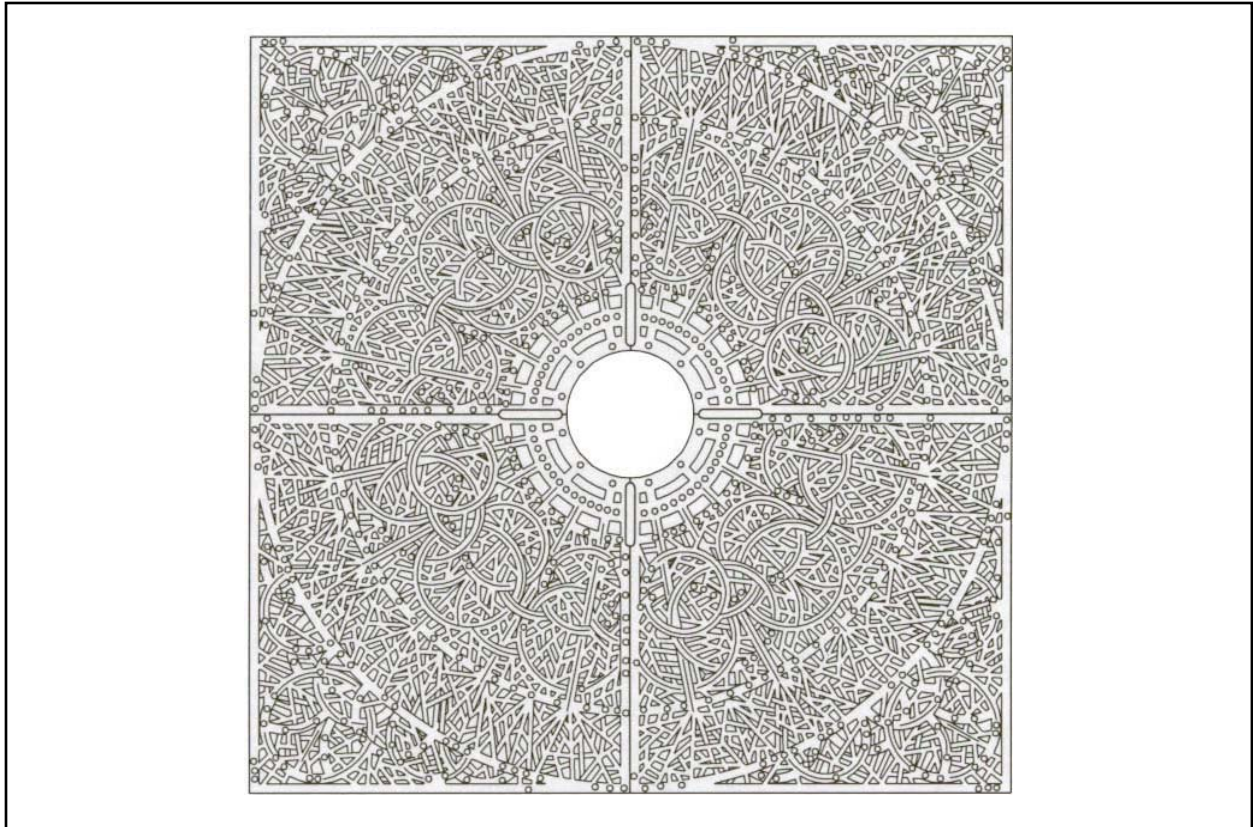

Figure T-22: Asian Pacific Tree Grate



# REVISED DRAFT

This Document is a draft pending final approval. Please contact a CCDC Planner @ (619) 235-2200 to discuss your project.

## *Children's Park Tree Grate*

The Children's Park Tree Grate shall be the Starburst Series 2: **three-eighths ( $\frac{3}{8}$ ) inch** slots, model number M9606-2, **four (4) foot by eight (8) foot**, two pieces, with one-piece steel frame unit, factory primed and painted black, by Ironsmith or approved equal (Figure T-23).

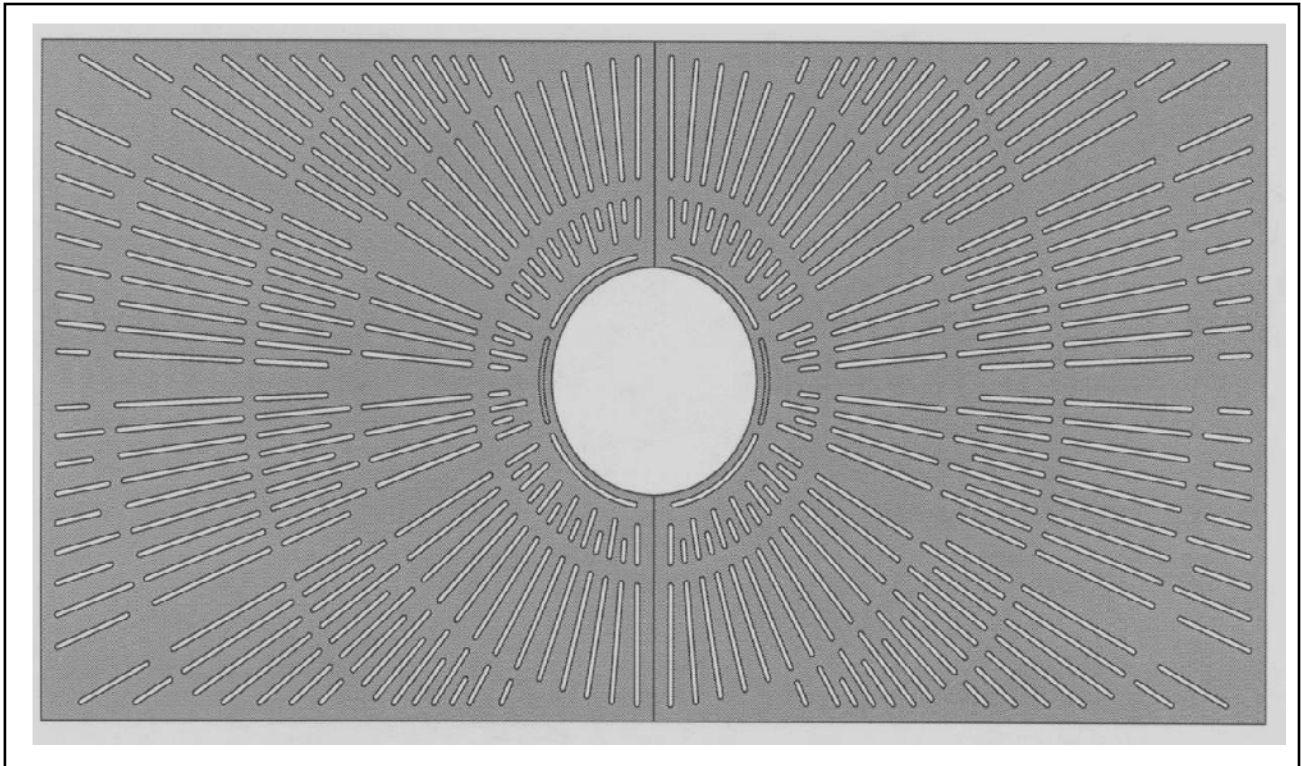

Figure T-23: Children's Park Tree Grate

# REVISED DRAFT

This Document is a draft pending final approval. Please contact a CCDC Planner @ (619) 235-2200 to discuss your project.

## *Park-to-Bay Tree Grate*

The Park-to-Bay Tree Grate shall be the Olympian, ¼-inch maximum slot openings, model number M9624-2, **four (4) foot by eight (8) foot**, two pieces, with one-piece steel frame unit, factory primed and painted black, by Ironsmith or approved equal (Figure T-24).

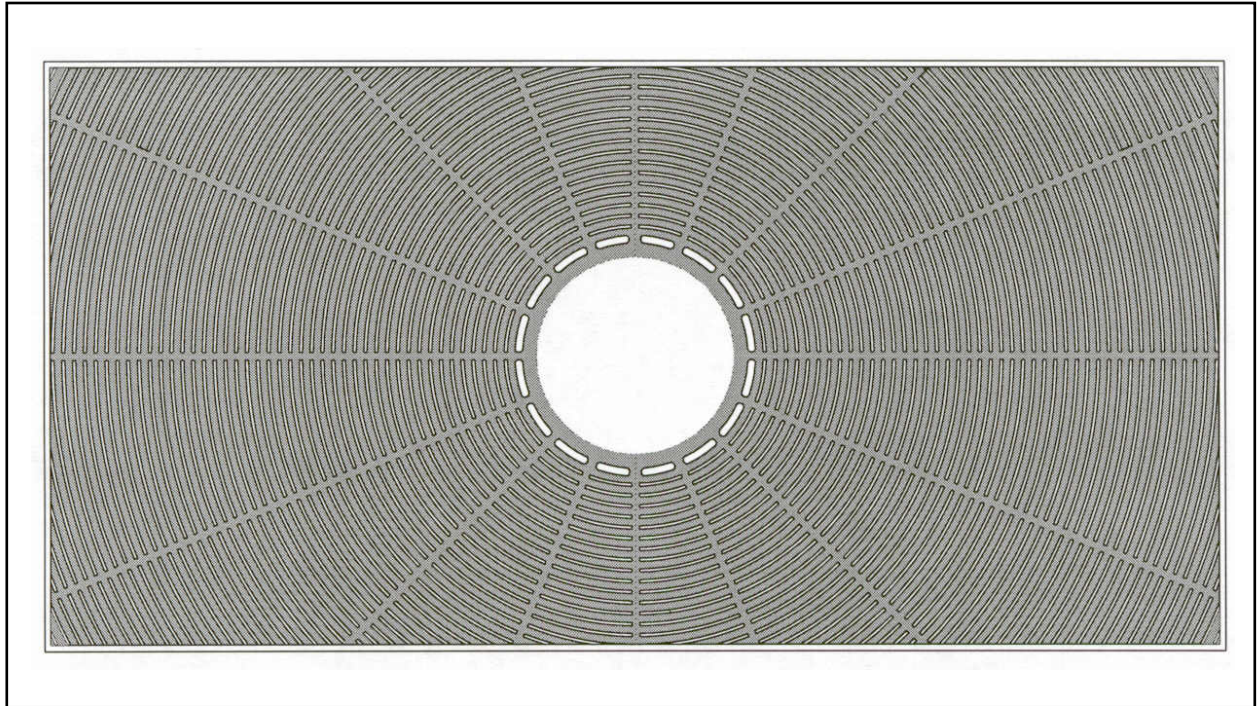

Figure T-24: Park-to-Bay Tree Grate

# REVISED DRAFT

This Document is a draft pending final approval. Please contact a CCDC Planner @ (619) 235-2200 to discuss your project.

## STREET LIGHTING

### General Notes:

Contractor shall submit all street light specifications to CCDC's Construction Engineer for review and approval before ordering/installing new street lights in the public right-of-way. Contact CCDC at 619.235.2200.

### *Standard Light*

The Standard Light (Type C) pole shaft and base shall be equal to the products as manufactured by Valley Iron and Steel (VISCO), Holophane Outdoor Architectural Lighting, South Bay Foundry, or Antique. For any other substitution, detailed shop drawings together with complete photometrics shall be submitted for approval with the initial submittal of Street Lighting Improvement Plans.

The height of the Standard light fixture shall be **twelve (12) feet** measured from the bottom of the base to the center of the light source (Figure T-25).

The Pole Assembly shall be all cast aluminum or iron and supplied in one-piece unitized construction. The complete pole assembly shall be composed of the following:

1. Pole shaft shall be a one-piece steel fluted **eleven (11) gauge** pole approximately **six (6) inches** at the bottom and tapered toward the top. The pole base shall be a one-piece aluminum or iron casting with a **.500-inch** average wall thickness. The shaft shall have **sixteen (16)** uniform and sharply defined flutes extending approximately **ninety-two (92) inches** long and shall have a cast in tenon **three (3) inches** in diameter by three **(3) inches** high.
2. Base plate shall be of structural grade A36 steel. The pole shaft will telescope the base plate and be circumferentially welded at top and bottom. The base plate shall be approximately **nine (9) inches** square and with an approximately **eight and a half (8-1/2) inch** bolt circle for attachment to anchor bolts.

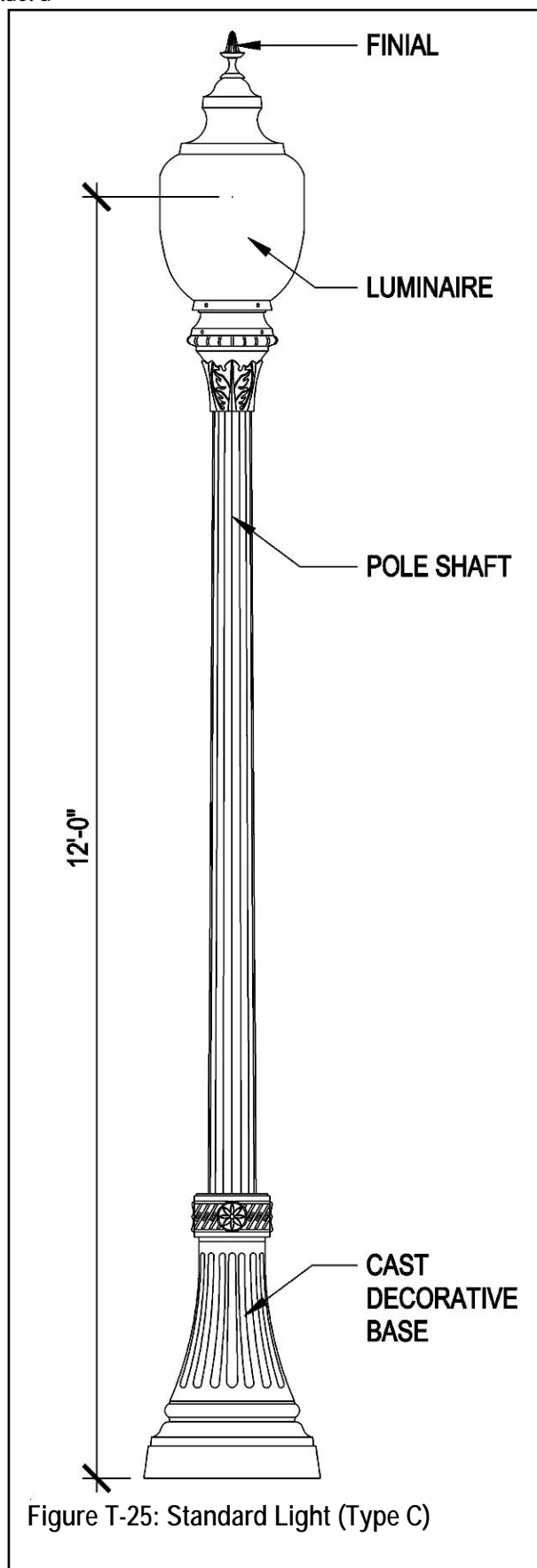

# REVISED DRAFT

This Document is a draft pending final approval. Please contact a CCDC Planner @ (619) 235-2200 to discuss your project.

3. Anchor bolts shall be fabricated from a structural hot-rolled bar of special quality A36 material and shall conform to (ASTM A307) specifications. All anchor bolts shall have an L-bend at the bottom, the length of which shall not exceed four times the thickness of the bolt. All anchor bolts shall be hot dipped galvanized according to ASTM-153 galvanizing specifications. Each anchor bolt shall be supplied with one hex nut for leveling, one hex nut for securing base, and two flat washers.
4. Hand hole shall be a **three (3) inch by five (5) inch** rectangle with locking cover located in the pole shaft. The hand hole shall be located below decorative base cover and aligned with base access door facing the street. A grounding lug shall be provided inside the hand hole for bonding of equipment ground conductors.
5. Cast decorative base shall be approximately **thirty-two (32) inches** high and a base width of approximately **nineteen (19) inches**. The base shall be cast aluminum, iron, or steel with an average thickness of **.500 inches**. The decorative base shall have **sixteen (16) flutes** each approximately **one (1) inch by thirteen and a half (13½) inches** long. The flutes shall have a uniform and well-defined shape. The top of the fluted base shall have a **four (4) flowered decorative bezel** approximately **eight (8) inches** in diameter by **five (5) inches** high. There shall be flutes on the inside diameter to match the pole.

Base to have decorative fairing (reduced collar) approximately **eight and three-quarter (8¾) inches** inside diameter (I.D.) mounted to base top. At completion of job, the contractor shall caulk with silicone between fluted shaft and collar near base.

6. Luminaire with **eighty five (85) Watt Induction 4000K QL Phillips** shall be **forty-three and seven-eighths (43¾) inches** in overall height with a maximum diameter of **seventeen and one-quarter (17¼) inches**, mounted atop the pole on arm assembly. Assembly shall be equal to the product as manufactured by Holophane Outdoor Architectural Lighting, Visco, Powerlux or approved equal. All luminaires will come with a minimum 10-year full warranty.

All fixtures shall be Full Cutoff Optics (FCO) Type Fixture. An FCO Type Fixture is a luminaire or light fixture that, by design of the housing, reflector, lens and lamp assembly, does not allow any light dispersion or direct glare to shine above the horizontal plane measured from the lowest light emitting portion of the fixture as installed. Each luminaire shall be composed of the following:

- a. Decorative globe holder of cast aluminum or iron (356.1 ingot) with a **.500-inch** nominal wall thickness. Luminaire housing shall have a decorative leaf-style detailing.
- b. Each luminaire base described above shall house the required QL Phillips voltage ballast assembly, a borosilicate glass prismatic acorn refractor and globe holder. The luminaries shall utilize tool-less entry for ease of maintenance. The fixture shall be U.L. wet-listed and U.L. listed 40 degrees C.
- c. The optical system consists of a precisely molded thermal-resistant borosilicate glass refractor and reflector. The upper portion of this system incorporates a series of reflecting prisms that redirects the upward light into the controlling refractor while allowing a soft upright component to define the traditional acorn shape of the luminaire. A **five (5) inch** finial crowns the top and a stainless steel hinge and latch allow easy access for relamping. The lower refractor uses precisely molded prisms to maximize pole spacing while maintaining uniform illuminance.
- d. The ballast housing contains the ballast and other electrical components. The housing is cast of copper-free, certified 356.1 ingot aluminum alloy with a raised leaf pattern and is designed to flow gracefully from a **four (4) to five (5) inch** diameter decorative post. The slipfitter will accept **three**



# REVISED DRAFT

This Document is a draft pending final approval. Please contact a CCDC Planner @ (619) 235-2200 to discuss your project.

(3) inch high by two and seven-eighths (2-7/8) to **three and one-eighth (3 1/8) inch** outside diameter (O.D.) tenon and is secured by four hex screws. Four (4) uniquely designed stainless steel spring clips enclosed in a clear polyvinyl chloride sleeve and adjusted by **two (2) captive 1/4-20** stainless steel, hex-head bolts securely cradle the optical assembly.

- e. House Shields shall be required in residential areas as required by the specific project.

An alternative luminaire to the Borosilicate Glass Acorn shall be the #737 Acrylic Type III Acorn Globe manufactured by Valley Iron and Steel (VISCO), Powerlux or approved equal. All specifications and dimensions shall be equivalent to those as specified in this section.

- 7. Color shall be "CCDC Blue" PLS6 1008F blue TGIC by Sherwin Williams or approved equal. For paint substitution, a paint chip shall be submitted to CCDC for approval. All parts shall be finish-coated to match the specified custom color. The coating shall be a premium TGIC polyester powder coat. An acceptable alternative to powder coating shall be priming and painting. The light standard shall be factory primed. The finished paint shall be applied per the painting specifications either in the factory or after erected at the job site. If the finished coat is applied at the factory, any scrapes, chips or other damage caused by installation must be sanded, feathered, primed and then touched up, with the specified paint after reinstallation to eliminate any noticeable patches.
- 8. Concrete foundation shall be a minimum of **twenty-six (26) inches** in diameter and a minimum of **four (4) feet** deep. Concrete shall be as specified in "Standard Specifications for Public Works Construction" (Latest Edition). Grounding shall consist of a copper wire installed per the City of San Diego requirements and the "Standard Specifications for Public Works Construction" (Latest Edition)

# REVISED DRAFT

This Document is a draft pending final approval. Please contact a CCDC Planner @ (619) 235-2200 to discuss your project.

## *Enhanced Standard Light (Octagonal Base)*

The pole shall be manufactured by Valley Iron and Steel (VISCO) model number VI-C-1-F/12, or Union Metal Pacific Corporation model number #B 1775, or South Bay Foundry, or Antique, or approved equal (Figure T-26).

The height of the Enhanced Standard light fixture shall be **sixteen (16) feet** measured from the bottom of the base to the center of the light source.

The Enhanced Standard Light shall be composed of the following:

1. Pole shaft shall be a one-piece steel fluted **eleven (11) gauge** pole approximately **eight (8) inches** at the bottom and tapered toward the top. The pole base shall be a one-piece aluminum or iron casting with a .500-inch average wall thickness. The shaft shall have **sixteen (16)** uniform and sharply defined flutes and shall have a cast in tenon **three (3) inches** in diameter by **three (3) inches** high.
2. Decorative base shall be constructed of two-piece split cast iron ASTM-A48, Class 30, with an octagonal base **twenty-four (24) inches** in diameter.
3. Anchor bolts shall be fabricated per ASTM-A36M55 specifications. All anchor bolts shall have an L-bend at the bottom, the length of which shall not exceed four times the thickness of the bolt. All anchor bolts shall be hot dipped galvanized according to ASTM-153 galvanizing specifications. Each anchor bolt to be supplied with one hex nut for leveling, one hex nut for securing base and two flat washers. The anchor bolt thickness shall be **one (1) inch** by **thirty (30) inches**.
4. Hand hole shall be a minimum of **three (3) inch** by **five (5) inch** rectangle with locking cover located in the base. Hand hole shall be located below decorative

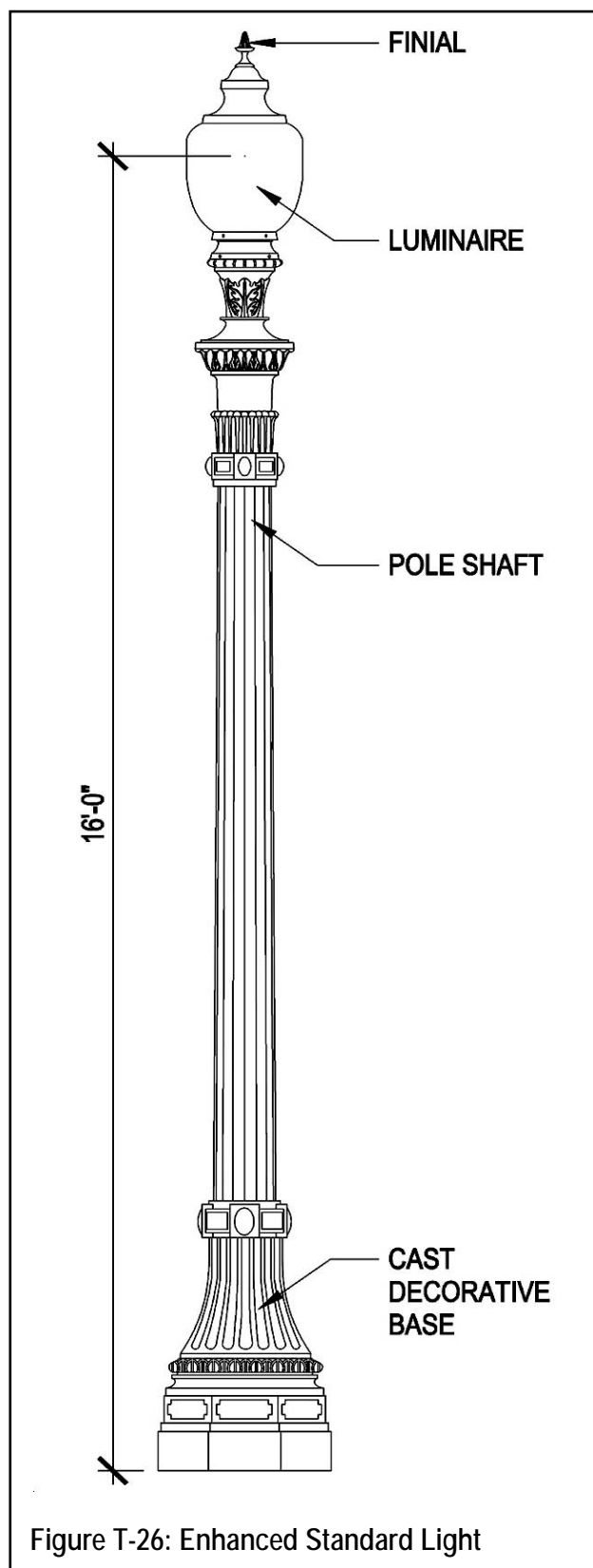

Figure T-26: Enhanced Standard Light

# REVISED DRAFT

This Document is a draft pending final approval. Please contact a CCDC Planner @ (619) 235-2200 to discuss your project.

base cover and aligned with base access door facing the street. A grounding lug shall be provided inside the hand hole for bonding of equipment ground conductors.

5. Luminaire with **eighty five (85) Watt Induction 4000K QL Phillips** shall be **forty-three and seven-eighths (43 $\frac{7}{8}$ ) inches** in overall height with a maximum diameter of **seventeen and one-quarter (17 $\frac{1}{4}$ ) inches**, mounted atop the pole on arm assembly. Assembly shall be equal to the product as manufactured by Holophane Outdoor Architectural Lighting, Visco, Powerlux or approved equal. All luminaires will come with a minimum 10-year full warranty.

All fixtures shall be Full Cutoff Optics (FCO) Type Fixture. An FCO Type Fixture is a luminaire or light fixture that, by design of the housing, reflector, lens and lamp assembly, does not allow any light dispersion or direct glare to shine above the horizontal plane measured from the lowest light emitting portion of the fixture as installed. Each luminaire shall be composed of the following:

- a. Decorative globe holder of cast aluminum or iron (356.1 ingot) with a .500-inch nominal wall thickness. Luminaire housing shall have a decorative leaf style detailing.
- b. House shields shall be required in residential areas as required by the specific project.
- c. Each luminaire base described above shall house the required QL Phillips voltage assembly, a borosilicate glass prismatic acorn refractor and globe holder. The luminaire shall utilize tool-less entry for ease of maintenance. The fixture shall be U.L. wet listed and U.L. listed at 40 degrees C.
- d. The optical system consists of a precisely molded thermal resistant borosilicate glass refractor and reflector. The upper portion of this system incorporates a series of reflecting prisms that redirects the upward light into the controlling refractor while allowing a soft upright component to define the traditional acorn shape of the luminaire. A **five (5) inch** finial crowns the top and a stainless steel hinge and latch allow easy access for relamping. The lower refractor uses precisely molded prisms to maximize pole spacing while maintaining uniform illuminance. The ballast housing contains the ballast and other electrical components. The housing is cast of copper-free, certified 356.1ingot aluminum alloy with a raised leaf pattern and is designated to flow gracefully from a **four (4) inch to five (5) inch** diameter decorative post. The slipfitter will accept **three (3) inch** high, **two and seven-eighths (2 $\frac{7}{8}$ ) to three and one-eighth (3 $\frac{1}{8}$ ) inch** O.D. tenon and is secured by four hex screws. **Four (4)** uniquely designed stainless steel spring clips enclosed in a clear polyvinyl chloride sleeve and adjusted by hex head stainless steel 1/4-20 bolts securely cradle the optical assembly.
- e. House Shields shall be required in residential areas as required by the specific project.

An alternative luminaire to the Borosilicate Glass Acorn shall be the #737 Acrylic Type III Acorn Globe manufactured by Valley Iron and Steel (VISCO), Powerlux or approved equal. All specifications and dimensions shall be equivalent to those as specified in this section.

6. Color shall be "CCDC Blue" PLS6 1008F blue TGIC by Sherwin Williams or approved equal. All parts shall be finish-coated to match the specified custom color. The coating shall be a premium TGIC polyester powder coat. An acceptable alternative to powder coating shall be priming and painting. The light standard shall be factory primed. The finished paint shall be applied per the

# REVISED DRAFT

This Document is a draft pending final approval. Please contact a CCDC Planner @ (619) 235-2200 to discuss your project.

painting specifications either in the factory or after erected at the job site. If the finished coat is applied at the factory, any scrapes, chips or other damage caused by installation must be sanded, feathered, primed and then touched up, with the specified paint after reinstallation to eliminate any noticeable patches.

7. Concrete foundation shall be a minimum of **thirty-one (31) inches** diameter and a minimum of **four (4) feet** deep. Concrete shall be as specified in "Standard Specifications for Public Works Construction" (Latest Edition). Grounding shall consist of a copper wire installed per the City requirements and the "Standard Specifications for Public Works Construction" (Latest Edition).

## *Little Italy Enhanced Standard Light*

The Little Italy Enhanced Standard Light shall meet all of the same requirements as the Enhanced Standard Light (Figure T-26) but shall be Tiger Drylac RAL #6005 Powder Coat (Dark Green) or approved equal for the Little Italy Neighborhood. For paint substitution, a paint chip shall be submitted to CCDC for approval. All parts shall be finish-coated to match the specified custom color. The coating shall be a premium TGIC polyester powder coat. An acceptable alternative to powder coating shall be priming and painting. The light standard shall be factory primed. The finished paint shall be applied per the painting specifications either in the factory or after erected at the job site. If the finished coat is applied at the factory, any scrapes, chips or other damage caused by installation must be first sanded, feathered, primed and then touched up, with the specified paint after reinstallation to eliminate any noticeable patches.

# REVISED DRAFT

This Document is a draft pending final approval. Please contact a CCDC Planner @ (619) 235-2200 to discuss your project.

## Gateway Light

The Gateway Light (Type A) pole shaft and base shall be equal to the product as manufactured by Valley Iron and Steel (VISCO) model number VI-C-C2-F/16 or Union Metal Pacific Corporation model number B1747, or by South Bay Foundry, Continental or Antique. For any other substitution, detailed shop drawings together with complete photometrics shall be submitted for approval with the initial submittal of Street Lighting Improvement Plans.

The height of the Gateway light fixture shall be **twenty-one and a half (21½) feet** measured from the bottom of the base to the center of the light source (Figure T-27).

1. Pole shaft shall be one-piece steel tapered **sixteen (16) fluted, eleven (11) gauge** pole with base plate welded to pole. Pole shall be circumferentially welded to base plate. Shaft diameter shall not vary more than two inches from top to bottom.
2. Base plate shall be structural grade A36 steel. The pole shaft will telescope the base plate and be circumferentially welded at top and bottom. Base plate shall be approximately **twelve (12) inches** square and with an approximately **eleven and one-half (1½) inch** bolt circle for attachment to anchor bolts.
3. Anchor bolts shall be fabricated from a structural hot-rolled bar of special quality A36 material and shall conform to (ASTM A307) specifications. All anchor bolts shall have an L-bend at the bottom, the length of which shall not exceed four times the thickness of the bolt. All anchor bolts shall be hot-dipped galvanized according to ASTM-153 galvanizing specifications. Each anchor bolt to be supplied with one hex nut for leveling, one hex nut for securing base and two flat washers. Hand hole shall be a **three (3) inch by five (5) inch** rectangle with locking cover located in the pole shaft. Hand hole in pole shaft shall be located below decorative base cover and aligned with base access door facing the street. A grounding lug shall be provided inside the hand hole for bonding of equipment ground conductors.

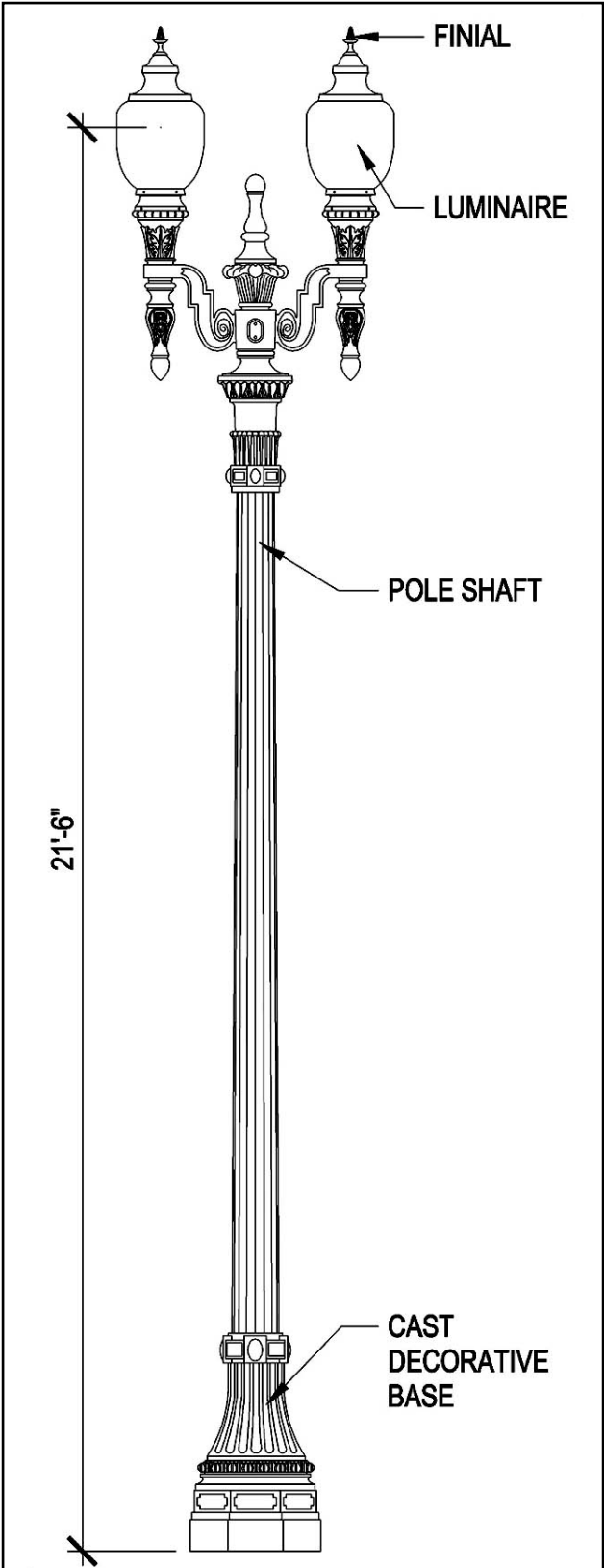

Figure T-27: Gateway Light (Type A)

# REVISED DRAFT

This Document is a draft pending final approval. Please contact a CCDC Planner @ (619) 235-2200 to discuss your project.

4. Cast decorative base shall have overall dimensions of approximately **forty (40) inches** high and approximately **twenty-four (24) inches** across the bottom. Base shall be cast aluminum or iron and conform in all details and dimensions to that of base detailed on drawing. Case base to be average minimum wall thickness of **.500 inch** and shall have an opening for access to hand hole. Base shall be secured to pole to provide adequate support to pole. All connections to be vandal-proof utilizing flush Allen-head screws. Volume II Base to have decorative fairing (reducer collar) approximately **eight and three-quarter (8¾) inches** I.D. mounted to base top. At completion of job, contractor shall caulk with silicone between fluted shaft and collar near base.
5. Luminaire with **two (2) one hundred sixty five (165) Watt Induction 4000K QL Phillips lamps** shall be **forty-three and seven-eighths (43⅞) inches** in overall height with a maximum diameter of **seventeen and one-quarter (17¼) inches**, mounted atop the pole on Arm Assembly. Assembly shall be equal to the product as manufactured by Holophane Outdoor Architectural Lighting, VISCO, Powerlux or approved equal. One photocell to be installed for each set of two luminaires, with shielding as required for correct photocell operation. All luminaires will come with a minimum ten (10) year full warranty.

All fixtures shall be Full Cutoff Optics (FCO) Type Fixture. An FCO Type Fixture is a luminaire or light fixture that, by design of the housing, reflector, lens and lamp assembly, does not allow any light dispersion or direct glare to shine above the horizontal plane measured from the lowest light emitting portion of the fixture as installed. Each luminaire shall be composed of the following:

- a. Decorative globe holder of cast aluminum (356.1 ingot) with a **.250-inch** nominal wall thickness. Luminaire housing shall have a decorative leaf style detailing.
- b. House shields shall be required in residential areas as required by the specific project.
- c. Each luminaire base described above shall house the required voltage QL Phillips assembly, a borosilicate glass prismatic acorn refractor and globe holder. The luminaire shall utilize tool-less entry for ease of maintenance. The fixture shall be U.L. wet listed and U.L. listed at 40 degrees C.
- d. The optical system consists of a precisely molded thermal-resistant borosilicate glass refractor and reflector. The upper portion of this system incorporates a series of reflecting prisms that redirects the upward light into the controlling refractor while allowing a soft upright component to define the traditional acorn shape of the luminaire. A **five (5) inch** finial crowns the top and a stainless steel hinge and latch allow easy access for relamping. The lower refractor uses precisely molded prisms to maximize pole spacing while maintaining uniform illumination.
- e. The ballast housing contains the ballast and other electrical components. The housing flow gracefully from a **four (4) to five (5) inch** diameter decorative post. The slipfitter will accept **three (3) inch** high, **two and seven-eighths (2⅞) to three and one-eighth (3⅛) inch** O.D. tenon and is secured by four hex screws. Four uniquely designed stainless steel spring clips enclosed in a clear polyvinyl chloride sleeve and adjusted by hex head stainless steel 1/4-20 bolts securely cradle the optical assembly.

An alternative luminaire to the Borosilicate Glass Acorn shall be the #737 Acrylic Type III Acorn Globe manufactured by Valley Iron and Steel (VISCO), Powerlux or approved



# REVISED DRAFT

This Document is a draft pending final approval. Please contact a CCDC Planner @ (619) 235-2200 to discuss your project.

equal. All specifications and dimensions shall be equivalent to those as specified in this section.

Note: The photometric performances are for each luminaire, i.e. the twin street light standard photometric performance shall be twice the stated values for double globes.

6. Arm assembly shall be of cast aluminum or iron, **.500-inch** nominal wall thickness with exterior appearance as detailed on drawing. It shall be mounted atop the pole and be secured with four stainless steel Allen-head set screws. Arm assembly shall have internal wireway suitable for wiring to the luminaries and shall be accessible by removal of side door on arm.
7. Color shall be "CCDC Blue" PLS6 1008F blue TGIC by Sherwin Williams or approved equal. For paint substitution, a paint chip shall be submitted to CCDC for approval. All parts shall be finish-coated to match the specified custom color. The coating shall be a premium TGIC polyester powder coat. An acceptable alternative to powder coating shall be priming and painting. The light standard shall be factory primed. The finished paint shall be applied per the painting specifications either in the factory or after erected at the job site. If the finished coat is applied at the factory, any scrapes, chips or other damage caused by installation must be sanded, feathered, primed and then touched up with the specified paint after reinstallation to eliminate any noticeable patches.
8. Concrete foundation shall be a minimum of a **thirty-one (31) inches** diameter and a minimum of **five (5) feet** deep. Concrete shall be as specified in "Standard Specifications for Public Works Construction" (Latest Edition). Grounding shall consist of a copper wire installed per the City of San Diego requirements and the "Standard Specifications for Public Works Construction" (Latest Edition).

# REVISED DRAFT

This Document is a draft pending final approval. Please contact a CCDC Planner @ (619) 235-2200 to discuss your project.

## Gaslamp Light

The Gaslamp Light shall be equal to the product as manufactured by Holophane Outdoor Architectural Lighting. For any other substitution, detailed shop drawings together with complete photometrics shall be submitted for approval with the initial submittal of Street Lighting Improvement Plans.

Luminaire shall consist of **five (5)** lighting fixtures mounted together on a decorative cluster bracket, each such luminaire assembly suitable for mounting atop an existing or new pole and rigidly secured by four hex screws. The mounting height of the new fixture shall be **eighteen (18)** feet to center of light source of upper luminaire (Figure T-28).

Where mounted atop an existing pole, a new luminaire shall have a fitter (designed for slipover complete with four set screws). Each luminaire shall consist of a **fifty-five (55) Watt 4000K QL Induction** land lighting fixture equal to Holophane Prismsphere Series Luminaire with opal outer sphere, come with a minimum ten (10) year full warranty, and the following:

1. Decorative globe holder of cast aluminum (356.1 ingot) with a .250-inch nominal wall thickness. Luminaire shall have convex octagon style detailing.
2. Each luminaire base described above shall house a HF generator, power coupler and globe holder. The luminaire shall utilize tool-less entry for ease of maintenance.
3. The globe shall be injection-molded acrylic, with opal outer sphere, which shall have a cast aluminum-mounting ring. Nominal dimension shall be **eighteen (18)** inches in diameter.
4. Luminaire shall be U.L. listed for wet locations and of maximum 25 degrees C ambient temp.

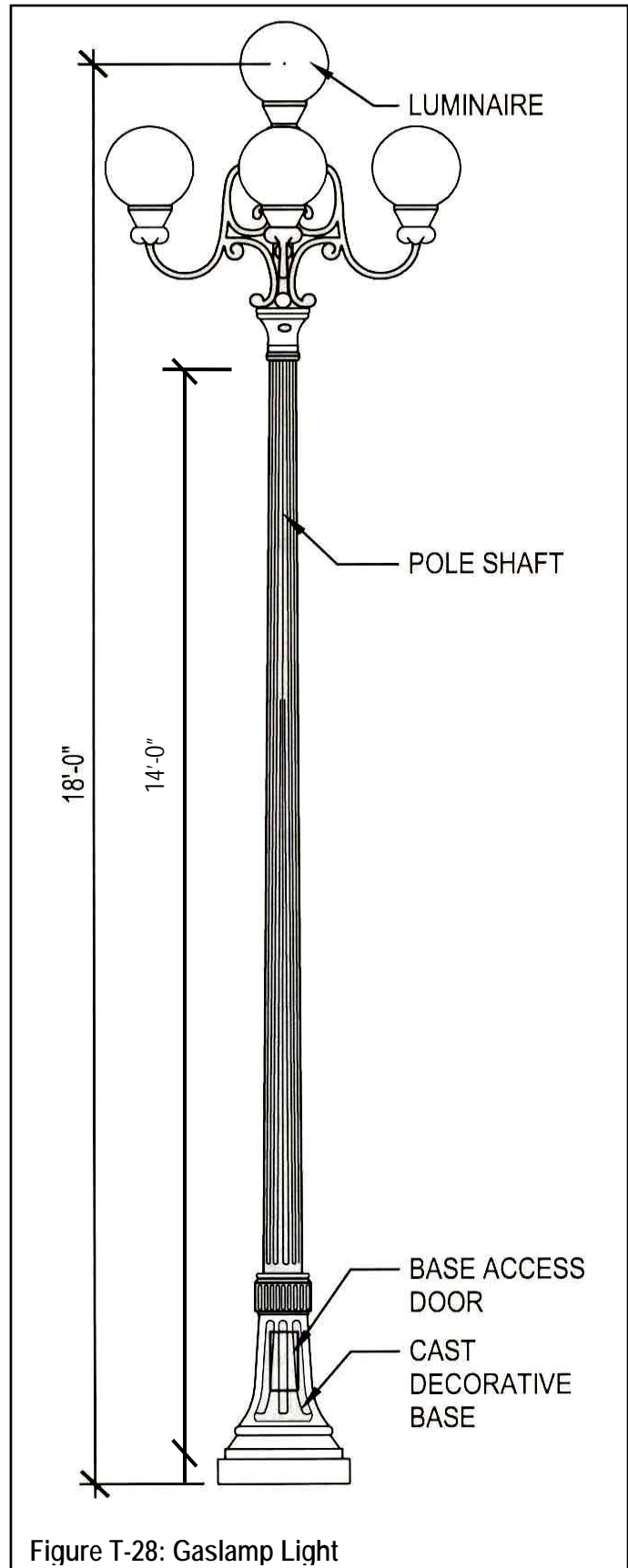

Figure T-28: Gaslamp Light

# REVISED DRAFT

This Document is a draft pending final approval. Please contact a CCDC Planner @ (619) 235-2200 to discuss your project.

The decorative cluster bracket shall be of one-piece cast aluminum or iron with nominal wall thickness of ½ inch and enclosing a ¼ inch diameter internal wireway to each of the five (5) lighting fixtures; each wireway shall be pre-wired with 90 C THHN/CU conductor, #10 AWG, from fixture base to pole top fitter and, in addition, an extra 15 feet of unspliced slack length of conductors shall be provided for drop down inside pole to remote splice compartment. All electrical components shall be U.L. listed and entire assembly shall be constructed as suitable for installation of outdoor wet locations.

1. Concrete foundation shall be a minimum of **two (2) feet** in diameter and a minimum of **five (5) feet** deep. Concrete shall be as specified in "Standard Specifications for Public Works Construction" (Latest Edition). Grounding shall consist of a copper wire installed per the City requirements and the "Standard Specifications for Public Works Construction" (Latest Edition).
2. Color shall be Federal Standard Color 27038 "Black" PBS2-40001 GIC by Sherwin Williams or approved equal. For paint substitution, a paint chip shall be submitted to CCDC for approval. All parts shall be finish-coated to match the specified custom color. The coating shall be a premium TGIC polyester powder coat. An acceptable alternative to powder coating shall be priming and painting. The light standard shall be factory primed. The finished paint shall be applied per the painting specifications either in the factory or after erected at the job site. If the finished coat is applied at the factory, any scrapes, chips or other damage caused by installation must first be sanded, feathered, primed and then touched up with the specified paint, after installation to eliminate any noticeable patches.

# REVISED DRAFT

This Document is a draft pending final approval. Please contact a CCDC Planner @ (619) 235-2200 to discuss your project.

## *Tear-Drop Fixture*

The Tear-Drop fixture shall be equal to the product as manufactured by Holophane Outdoor Architectural Products. For any other substitution, detailed shop drawings together with complete photometrics shall be submitted for approval.

The height of the Tear-Drop fixture shall be **twenty-two (22) feet** measured from the bottom of the base to the top of the light source. The total pole height shall be **twenty-four (24) feet and eight (8) inches**. The fixture shall contain banner arms with a **thirty (30) inch** span at heights of **twelve (12) feet and seventeen (17) feet** from the base. The fixture shall consist of a decorative, octagonal clamshell base, a tapered, octagonal shaft with 2 banner arms, a twin-arm crossarm with an octagonal pattern, and Holophane Memphis style luminaires. Fixture details shall be as follows (Figure T-29).

1. Post base shall be a cast-iron (ASTM A48, class 30) construction two-piece clamshell with a collar at the base to shaft transition. Two doors (with tamper-resistant hardware) are to be provided in the base.
2. Shaft shall be tapered octagonal **seven (7) gauge** steel with a steel tenon for cross-arm mounting, and a **twelve (12) inch** square steel anchor plate. Shaft shall taper from **eight and five-eighths (8<sup>5</sup>/<sub>8</sub>) inches** (flat-to-flat) at the anchor plate at **0.14 inch/foot**.
3. Cross-arm shall be cast aluminum (356.1 ingot alloy) construction and measure **forty-eight (48) inches** between luminaire centers and have a **one and a half (1½) inch** NPT fitting provided for luminaire mounting.
4. Banner arm shall be a **three-quarter (¾) inch** schedule 80 steel pipe construction with a half-sphere finial. The arm shall mount to a coupling welded to the shaft.

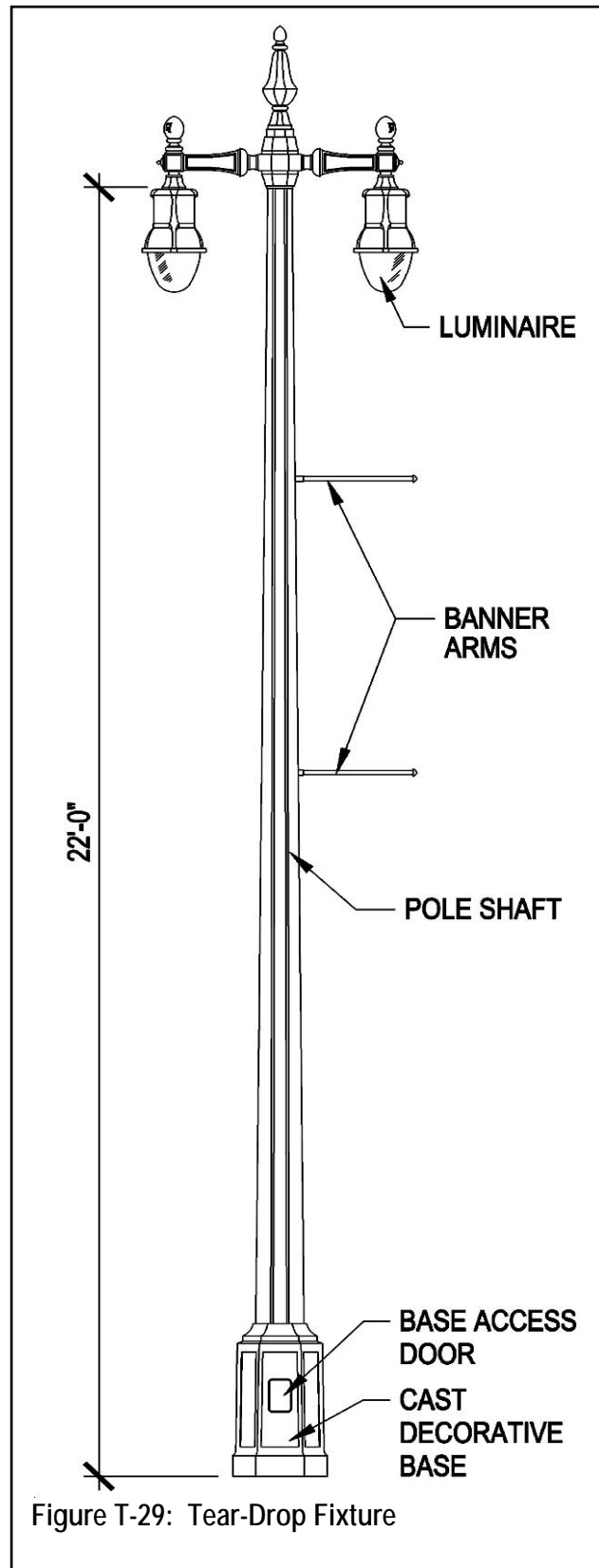

Figure T-29: Tear-Drop Fixture

# REVISED DRAFT

This Document is a draft pending final approval. Please contact a CCDC Planner @ (619) 235-2200 to discuss your project.

5. The finish shall be prime painted for a TNEMEC finish. Color shall be "CCDC Blue" PLS6 1008F blue TGIC by Sherwin Williams or approved equal.
6. Luminaire shall be a **one hundred sixty five (165) watt 4000K** Induction QL Phillips tear-drop style. The cast aluminum door shall cradle the tear-drop shaped thermal resistant borosilicate glass refractor that controls the light to provide an I.E.S. type III cut-off distribution. The refractor assembly shall hinge from the electrical/refractor assembly. All luminaires will come with a minimum ten (10) year full warranty.

# REVISED DRAFT

This Document is a draft pending final approval. Please contact a CCDC Planner @ (619) 235-2200 to discuss your project.

## *Asian Pacific Fixture*

Pole shaft and base shall be as manufactured by Valley Iron and Steel (VISCO) or Holophane Outdoor Architectural Lighting or approved equal.

The height of the Standard light fixture shall be **fourteen (14) feet** measured from the bottom of the base to the center of the light fixture.

The Pole Assembly shall be all cast aluminum or iron and supplied in one-piece unitized construction. The complete pole assembly shall be composed of the following (Figure T-30).

1. Pole Shaft shall be one-piece steel fluted **eleven (11) gauge** pole approximately **six (6) inches** at the bottom and tapered toward the top. The pole shaft shall be a one-piece aluminum or steel casting with a **.200 inch** average wall thickness. The shaft shall have **sixteen (16)** uniform and sharply defined flutes extending approximately **ninety-two (92) inches** long and shall have a cast-in tenon **three (3) inches** in diameter by **three (3) inches** high.
2. Base plate shall be constructed of structural grade A36 steel. The pole shaft will telescope the base plate and be circumferentially welded at top and bottom. Base plate shall be approximately **nine (9) inches** square and with an **approximately eight and one-half (8½) inch** bolt circle for attachment to anchor bolts.
3. Anchor Bolts shall be fabricated from a structural hot-rolled bar of special quality A36 material and shall conform to ASTM A307 specifications. All anchor bolts shall have an L-bend at the bottom, the length of which shall not exceed four times the thickness of the bolt. All anchor bolts shall be hot-dipped galvanized according to ASTM-153 galvanizing specifications. Each anchor bolt shall be supplied with one hex nut for leveling, one hex nut for securing base, and two flat washers.

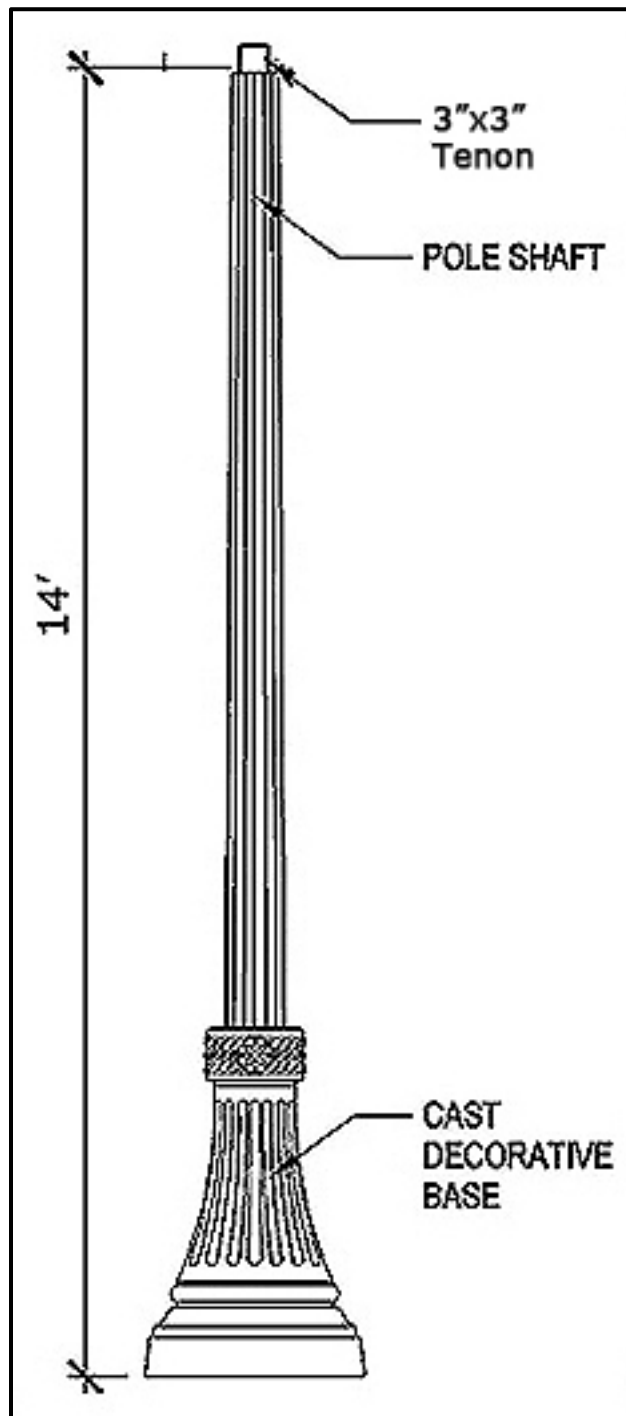

Figure T-30: Asian Pacific Street Light Pole



# REVISED DRAFT

This Document is a draft pending final approval. Please contact a CCDC Planner @ (619) 235-2200 to discuss your project.

4. Hand hole shall be a **three (3) inch** by **five (5) inch** rectangle with locking cover located in shaft. Hand hole shall be located below decorative base cover and aligned with base access door facing the street. A grounding lug shall be provided inside the hand hole for bonding of equipment ground conductors.
5. Cast Decorative Base shall be approximately **twenty-six (26) inches** high and a base width of approximately **nineteen (19) inches**. The base shall be cast aluminum, iron or steel with an average thickness of **.200 inches**. The decorative base shall have **sixteen (16) flutes** each approximately **one (1) inch** by **thirteen and one-half (13½) inches** long. The top of the flutes base shall have a **four (4) flowered decorative bezel** approximately **eight (8) inches** in diameter by **five (5) inches** high. Base to have decorative fairing (reduced collar) approximately **eight and three-quarters (8¾) inches** (I.D.) mounted to base top. At completion of job, contractor shall caulk with silicone between fluted shaft and color near base.
6. Color shall be Tiger Drylac RAL#6028 or approved equal. All parts shall be finish-coated to match the specified custom color. The coating shall be a premium TGIC polyester powder coat.

# REVISED DRAFT

This Document is a draft pending final approval. Please contact a CCDC Planner @ (619) 235-2200 to discuss your project.

## Asian Pacific Light

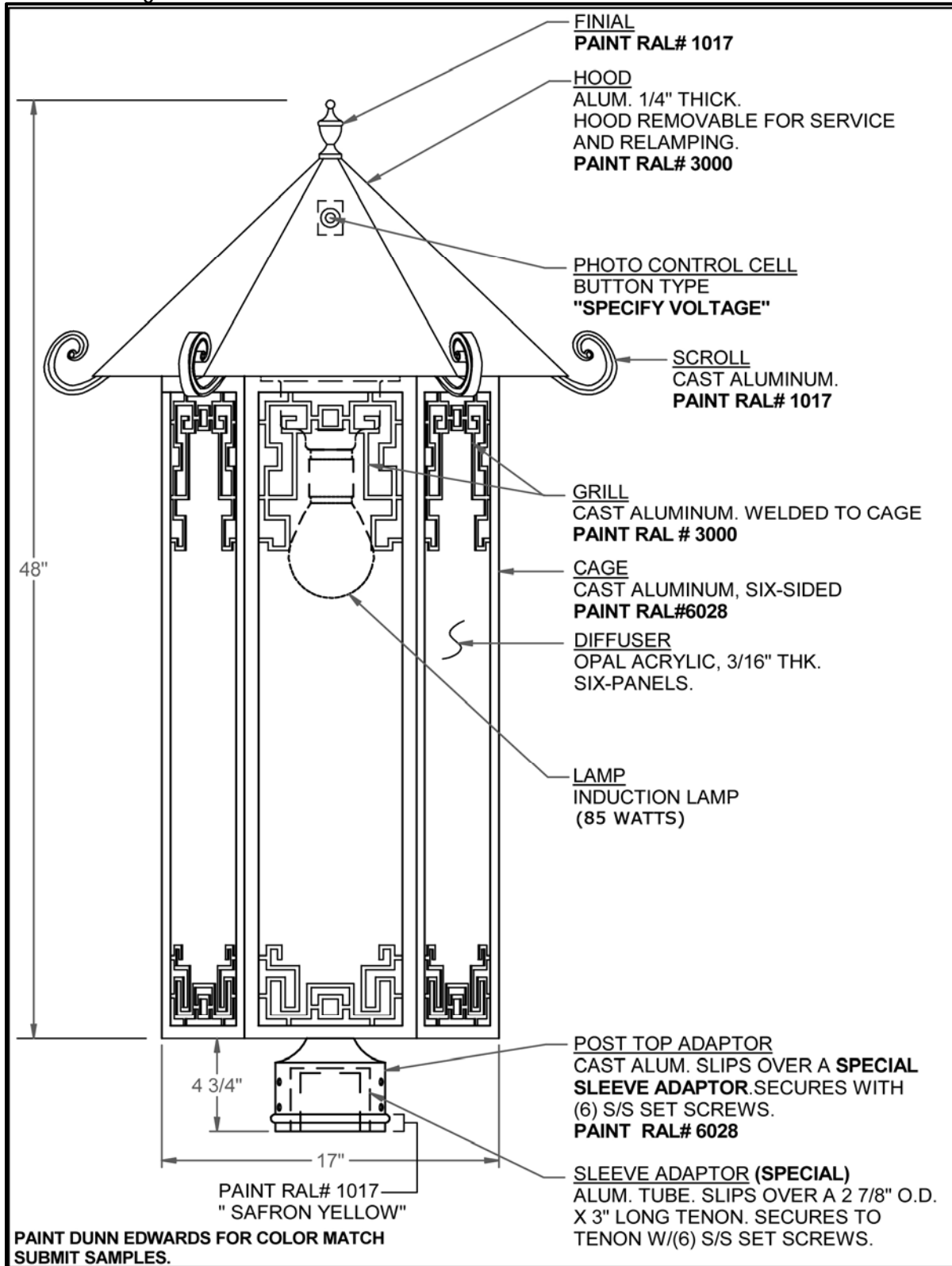

Figure T-31: Asian Pacific Light

# REVISED DRAFT

This Document is a draft pending final approval. Please contact a CCDC Planner @ (619) 235-2200 to discuss your project.

The light fixture shall be the Asian Pacific District lamp manufactured by architectural area lighting (c95a-1020) or approved equal. Lamp height shall be forty-eight (48) inches and width shall be seventeen (17) inches. Asian Pacific District lamp shall be composed of the following components:

1. Cage shall be **six (6)** sided cast aluminum. Paint shall be DE 409 UI 'Emerald Black' from Dunn-Edwards.
2. Diffuser shall contain six panels **three-sixteenths (3/16) inches** thick opal tinted acrylic.
3. Grill shall be cast aluminum, welded to the cage. Tracery shall be painted DE 874 U3 'Wineberry' from Dunn-Edwards.
4. Hood shall be **one-quarter (1/4) inch** Aluminum. Paint shall be DE 874 U3 'Wineberry'. Hood shall be removable for fixture re-lamping. Finial on top of hood shall be painted DE 1022 M3 from Dunn-Edwards.
5. Scroll shall be cast aluminum painted DE 1022 M3.
6. Lamp shall be **eighty five (85) Watt 4000K** induction QL Phillips, with twist lock photocell. Lamp holder voltage one **hundred twenty (120) volt** or **two hundred forty (240) volt** per field requirements. All luminaires will come with a minimum ten (10) year full warranty.

Concrete foundation shall be a minimum of **thirty-one (31) inches** diameter and a minimum of **four (4) feet** deep. Concrete shall be as specified in "Standard Specifications for Public Works Construction" (Latest Edition). Grounding shall consist of a copper wire installed per the City of San Diego requirements and the "Standard Specifications for Public Works Construction" (Latest Edition)

## *Type 15 Cobra Head Fixture*

Type 15 Cobra Head Fixture shall be a steel pole with a **twelve (12) foot** mast arm. Specifications and installation shall be per the requirements of the City of San Diego and the "Standard Specifications for Public Works Construction" (Latest Edition) with induction QL Phillips, with a minimum ten (10) year warranty or approved equivalent.

Color shall be "CCDC Blue" PLS6 1008F blue TGIC by Sherwin Williams or approved equal. All parts shall be finish-coated to match the specified custom color. The coating shall be a premium TGIC polyester powder coat. An acceptable alternative to powder coating shall be priming and painting. The light standard shall be factory primed. The finished paint shall be applied per the painting specifications either in the factory or after erected at the job site. If the finished coat is applied at the factory, any scrapes, chips or other damage caused by installation must be sanded, feathered, primed and then touched up with the specified paint after installation to eliminate any noticeable patches.

# REVISED DRAFT

This Document is a draft pending final approval. Please contact a CCDC Planner @ (619) 235-2200 to discuss your project.

## MISCELLANEOUS

### *CCDC Standard Litter Receptacle*

The CCDC Standard Litter Receptacle shall be Victor Stanley SD-42- (Dark Blue) or equal as determined by CCDC. All metal parts shall be primed and factory powder coated with CCDC Blue, see page A-39 for Litter Receptacle Colors for specific neighborhoods (Sherwin Williams # PLS6-10008F, RAL 5011). The wet paint equivalent for touch-up is Sherwin Williams B66T104 (Figure T-32).

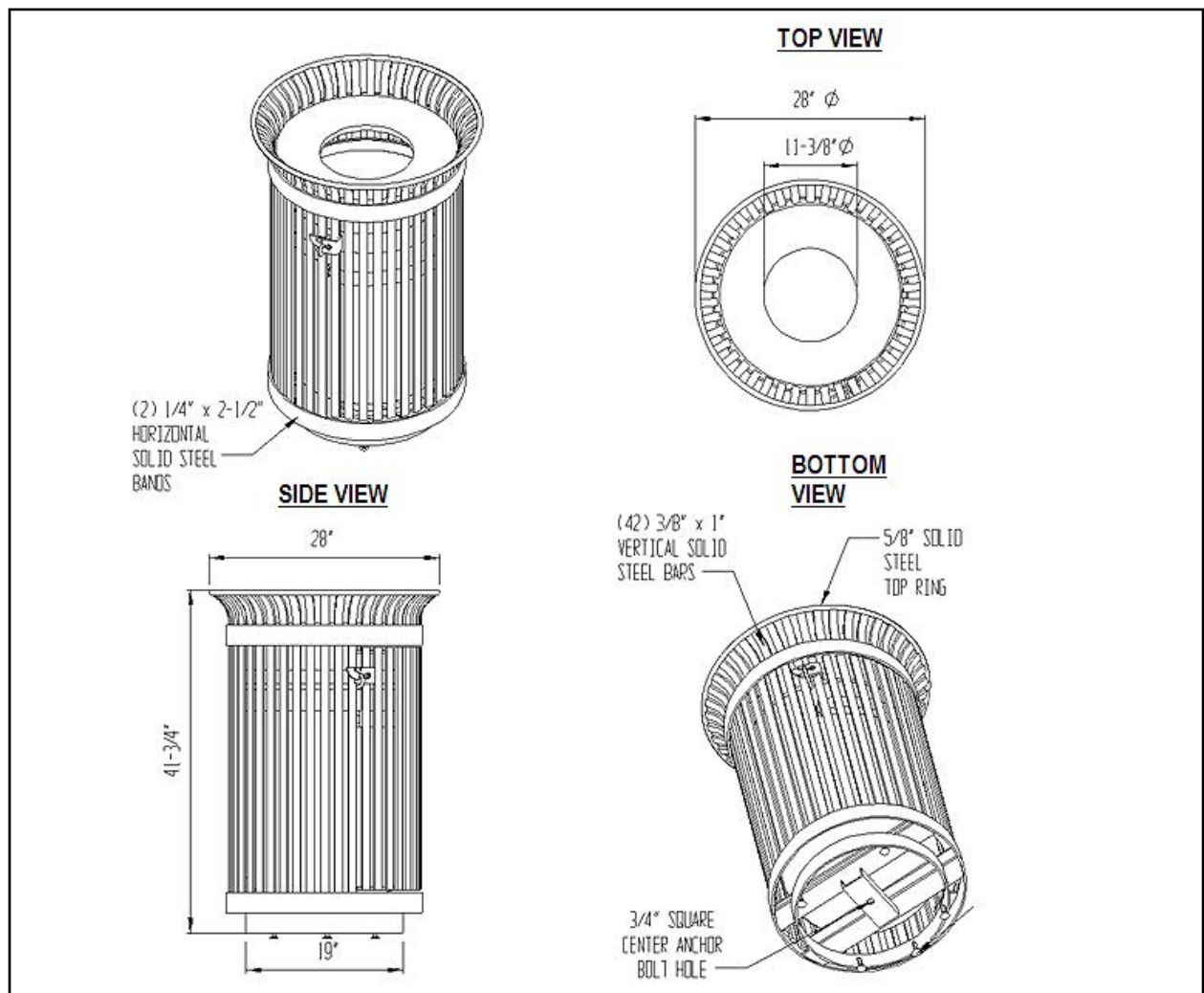

Figure T-32: CCDC Standard Litter Receptacle (Victor Stanley SD-42 or Approved Equal)

# REVISED DRAFT

This Document is a draft pending final approval. Please contact a CCDC Planner @ (619) 235-2200 to discuss your project.

## *Gaslamp Litter Receptacle*

The Gaslamp Litter Receptacle shall be Victor Stanley SD-42- Black RAL 9017 (Figure T-32).

## *Little Italy Litter Receptacle*

The Little Italy Litter Receptacle shall be Victor Stanley SD-42- Green, Tiger Drylac RAL 6005 (Figure T-32).

## *Park to Bay Litter Receptacle*

The Park to Bay Litter Receptacle shall be Victor Stanley SD-42- Dark Blue RAL 5011 (Figure T-32).

## *Anti-Graffiti Coating*

Anti-Graffiti Coating shall consist of a durable, silicone emulsion based, water repellent, non-yellowing, non-sacrificial coating and shall be "Ultrasield" with "Okon Sealer" by Dunn Edwards or approved equal. Graffiti removal shall be achieved with graffiti remover and hosing with water. See manufacturer's specifications and recommendations for application. The anti-graffiti coating shall be used on items determined by CCDC that need graffiti protection.

# REVISED DRAFT

This Document is a draft pending final approval. Please contact a CCDC Planner @ (619) 235-2200 to discuss your project.

## *Root Control Barrier*

Root barriers shall be a long-term root control barrier system consisting of **twenty-four (24) inch** height molded recycled plastic panels with a thickness of **.080-inches**. Panels shall be formed with **four (4), nine-sixteenths (9/16) inch**, integral external ribs per panel. The panels shall be connected with a locking strip as specified by the root barrier manufacturer.

Root barrier shall be by Bumblebee, Root Solution, and Century or approved equal.



# REVISED DRAFT

This Document is a draft pending final approval. Please contact a CCDC Planner @ (619) 235-2200 to discuss your project.

This Page Intentionally Left Blank

# REVISED DRAFT

This Document is a draft pending final approval. Please contact a CCDC Planner @ (619) 235-2200 to discuss your project.

## VII. CONSTRUCTION DETAIL APPENDIX

This appendix is not a part of the adopted Streetscape Manual. It is for reference only and may be updated by CCDC without requiring the Manual to be officially amended.

### Paving Details

All projects involving sidewalk and curb and gutter work that require streetwork per the City of San Diego "Schedule J" shall include street typical section.

*Typical Street Section*

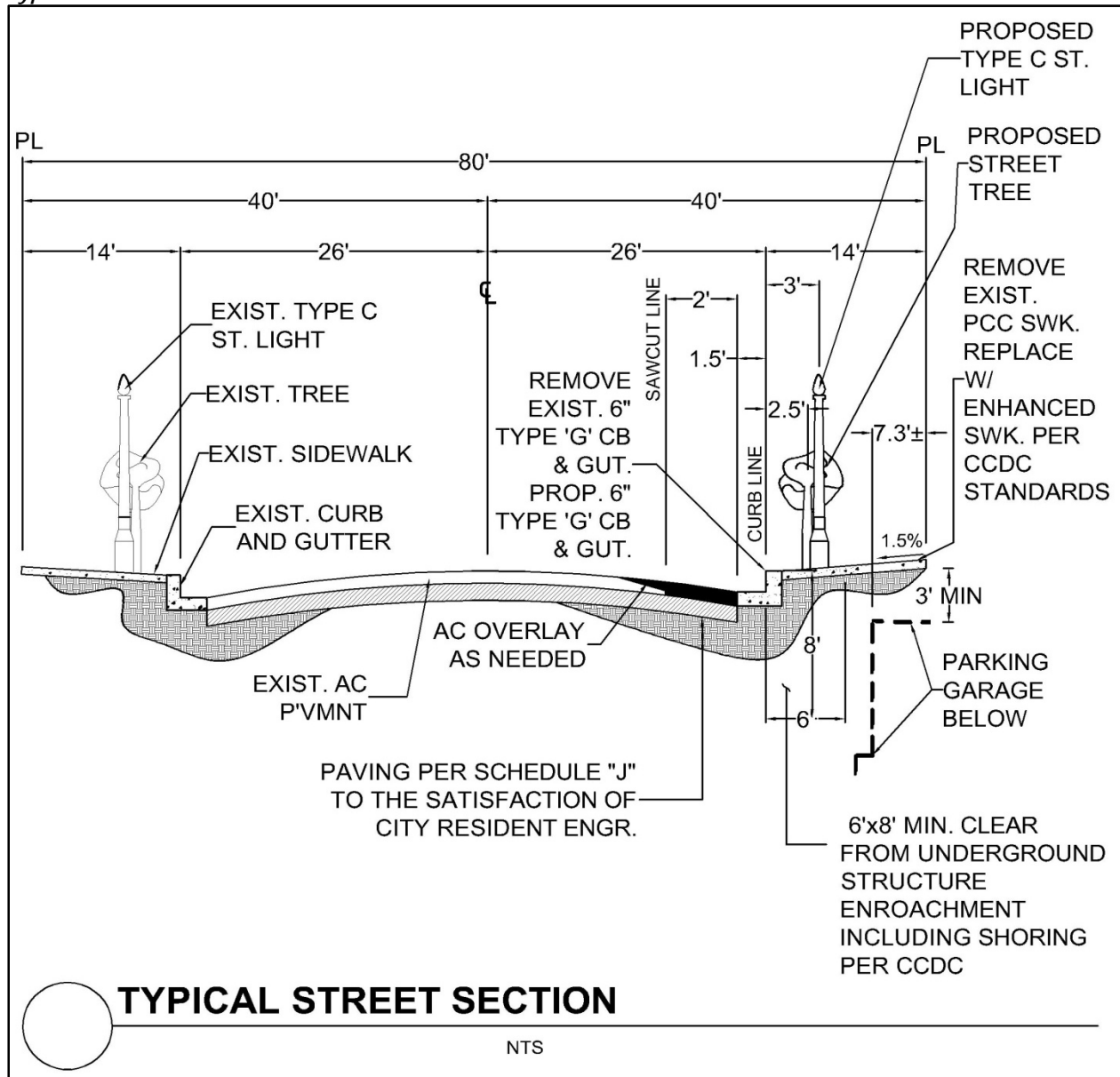

# REVISED DRAFT

This Document is a draft pending final approval. Please contact a CCDC Planner @ (619) 235-2200 to discuss your project.

## Brick Paving (Non-Vehicular)

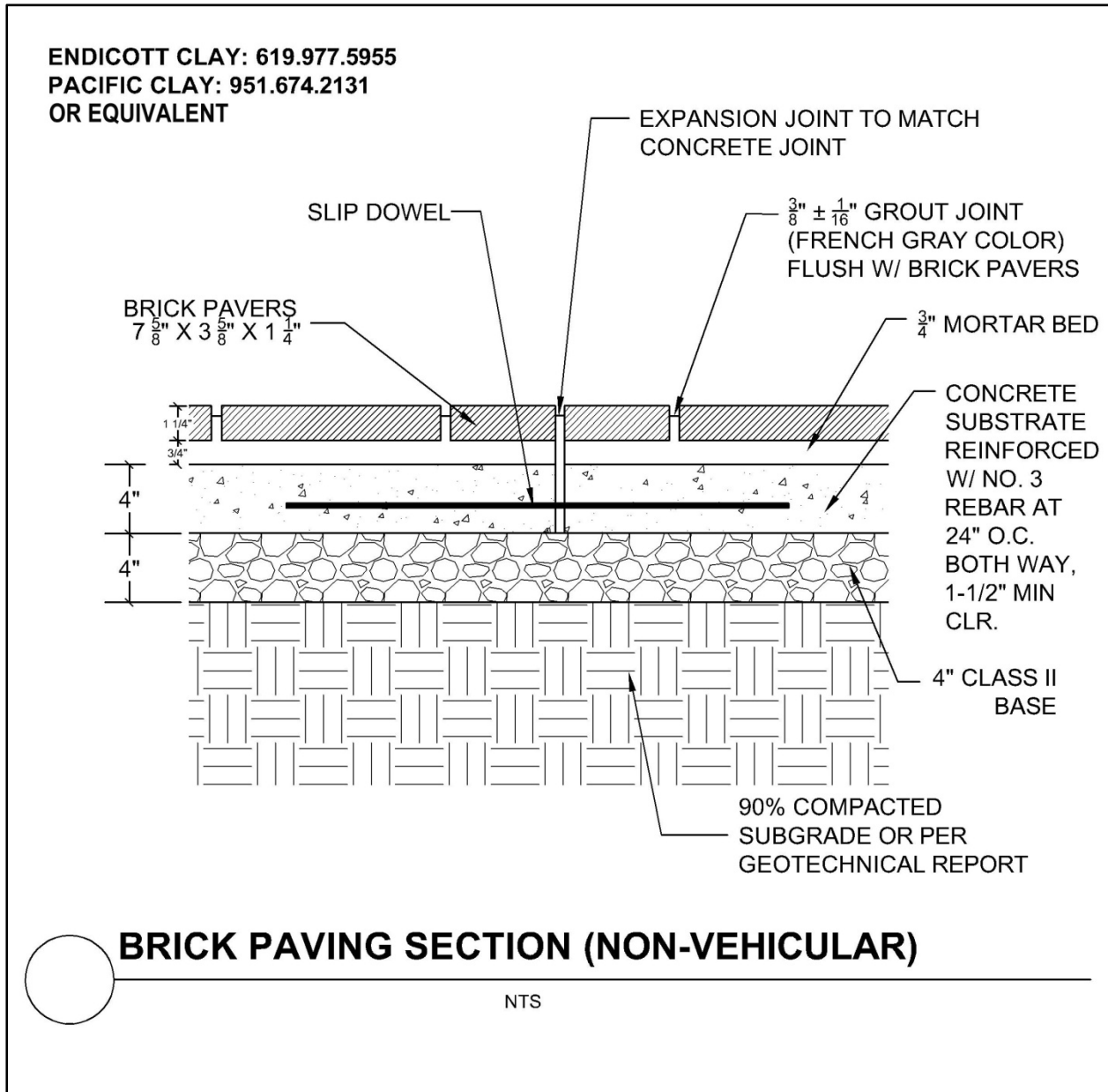

# REVISED DRAFT

This Document is a draft pending final approval. Please contact a CCDC Planner @ (619) 235-2200 to discuss your project.

## Brick Paving (Vehicular)

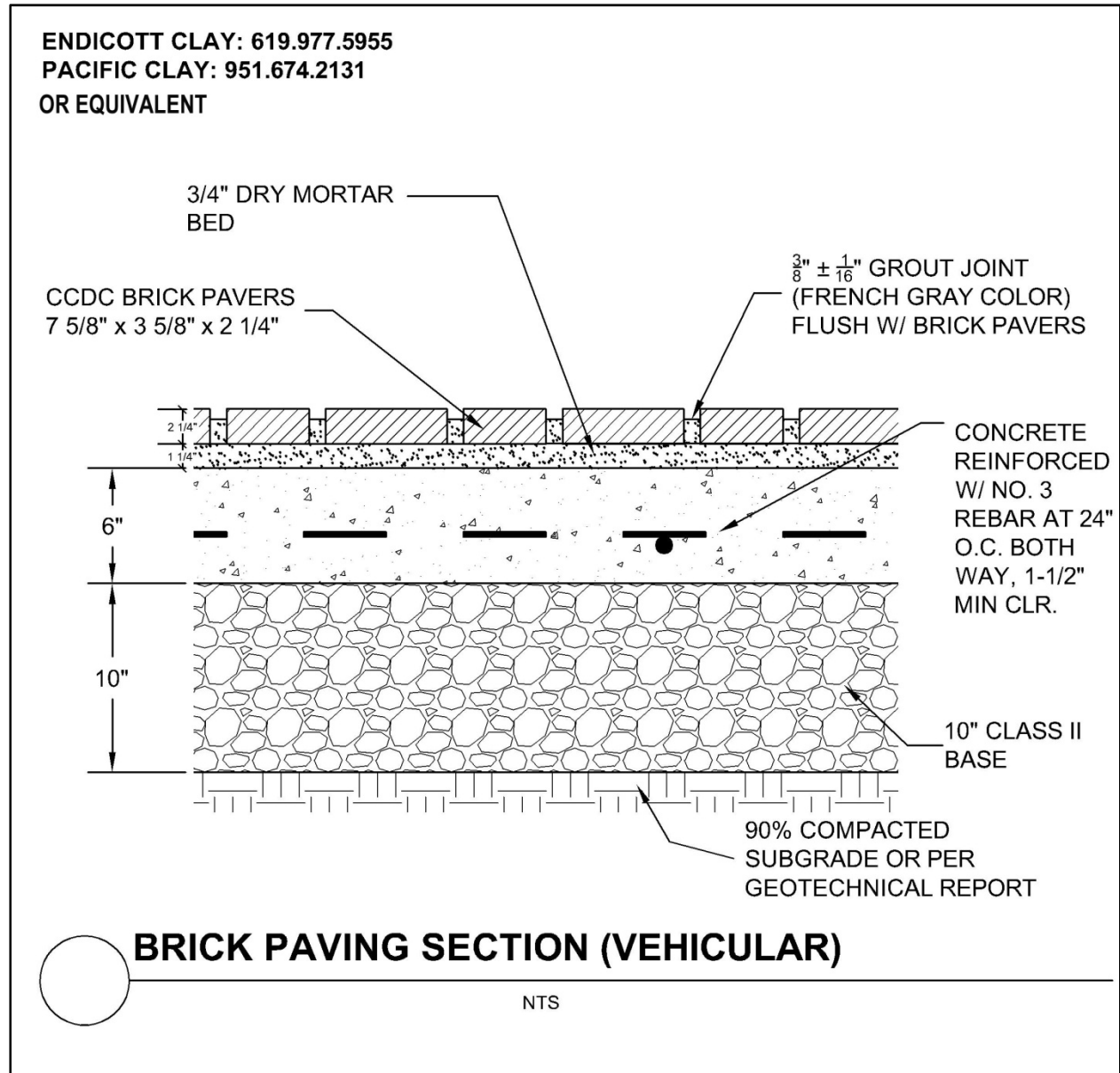

# REVISED DRAFT

This Document is a draft pending final approval. Please contact a CCDC Planner @ (619) 235-2200 to discuss your project.

## Brick Paving at Pedestrian Ramp

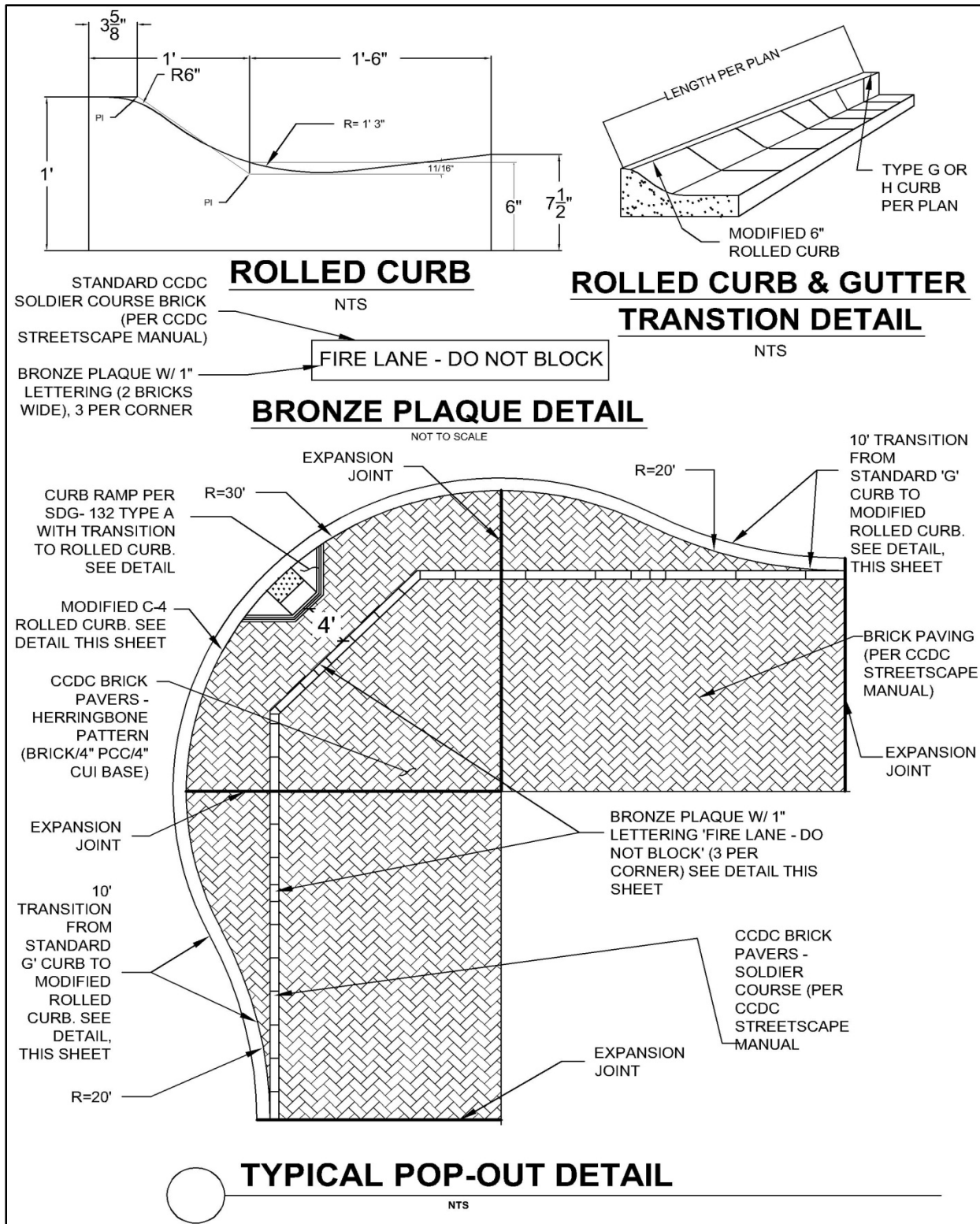



# REVISED DRAFT

This Document is a draft pending final approval. Please contact a CCDC Planner @ (619) 235-2200 to discuss your project.

## Brick Paving at Street Light

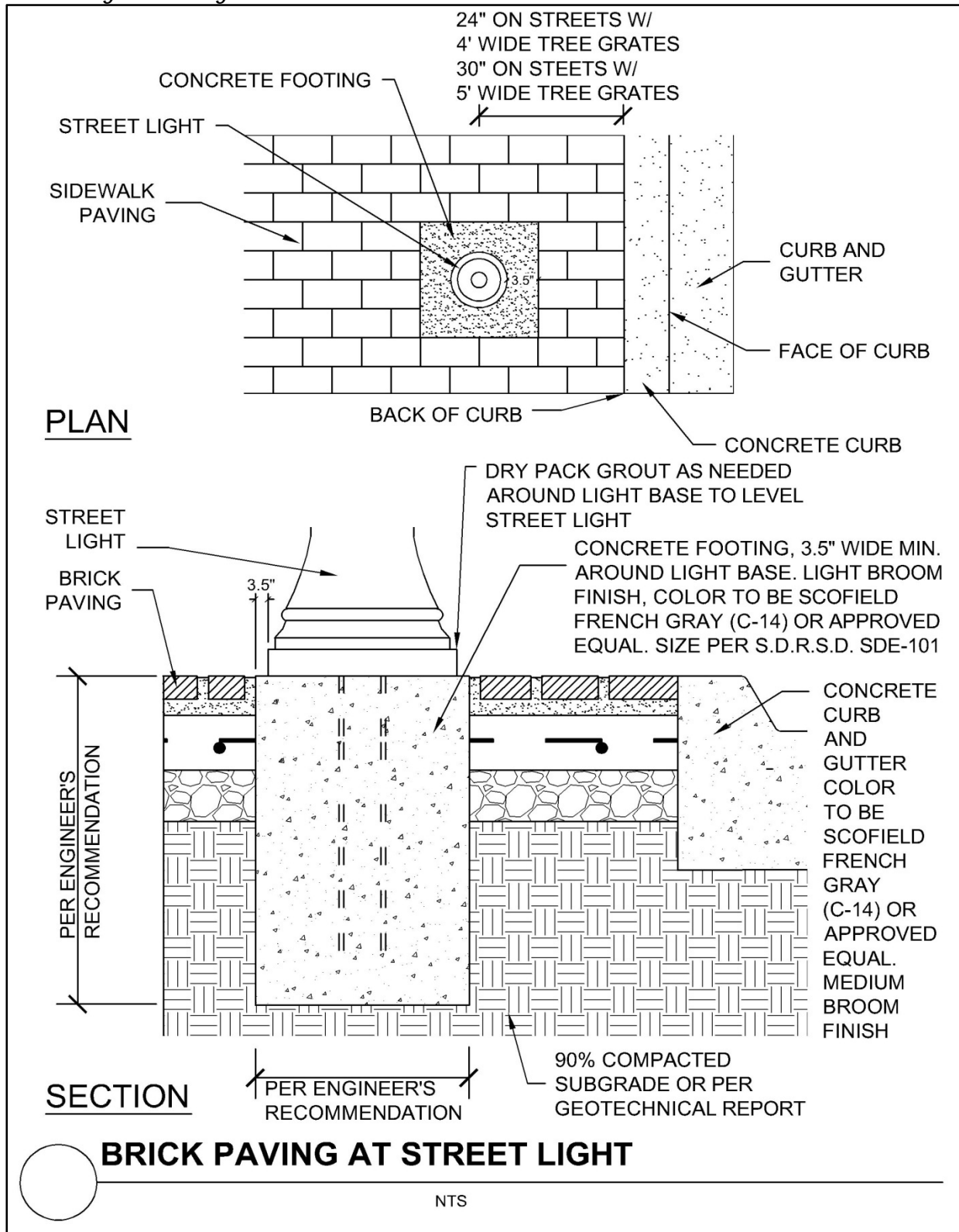

# REVISED DRAFT

This Document is a draft pending final approval. Please contact a CCDC Planner @ (619) 235-2200 to discuss your project.

## Brick Paving at Fire Hydrant

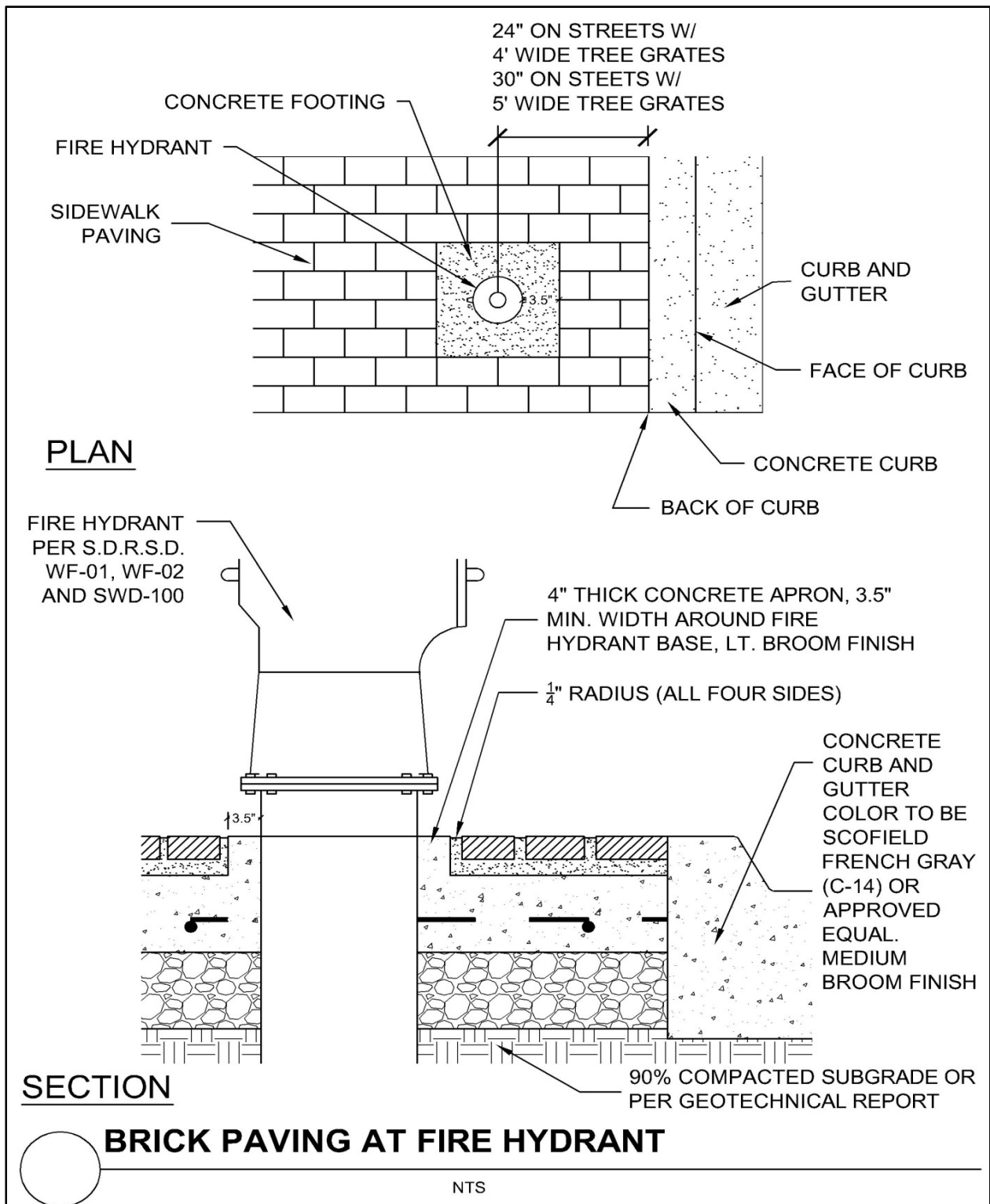

# REVISED DRAFT

This Document is a draft pending final approval. Please contact a CCDC Planner @ (619) 235-2200 to discuss your project.

## Brick Paving at Parking Meter/Street Signs

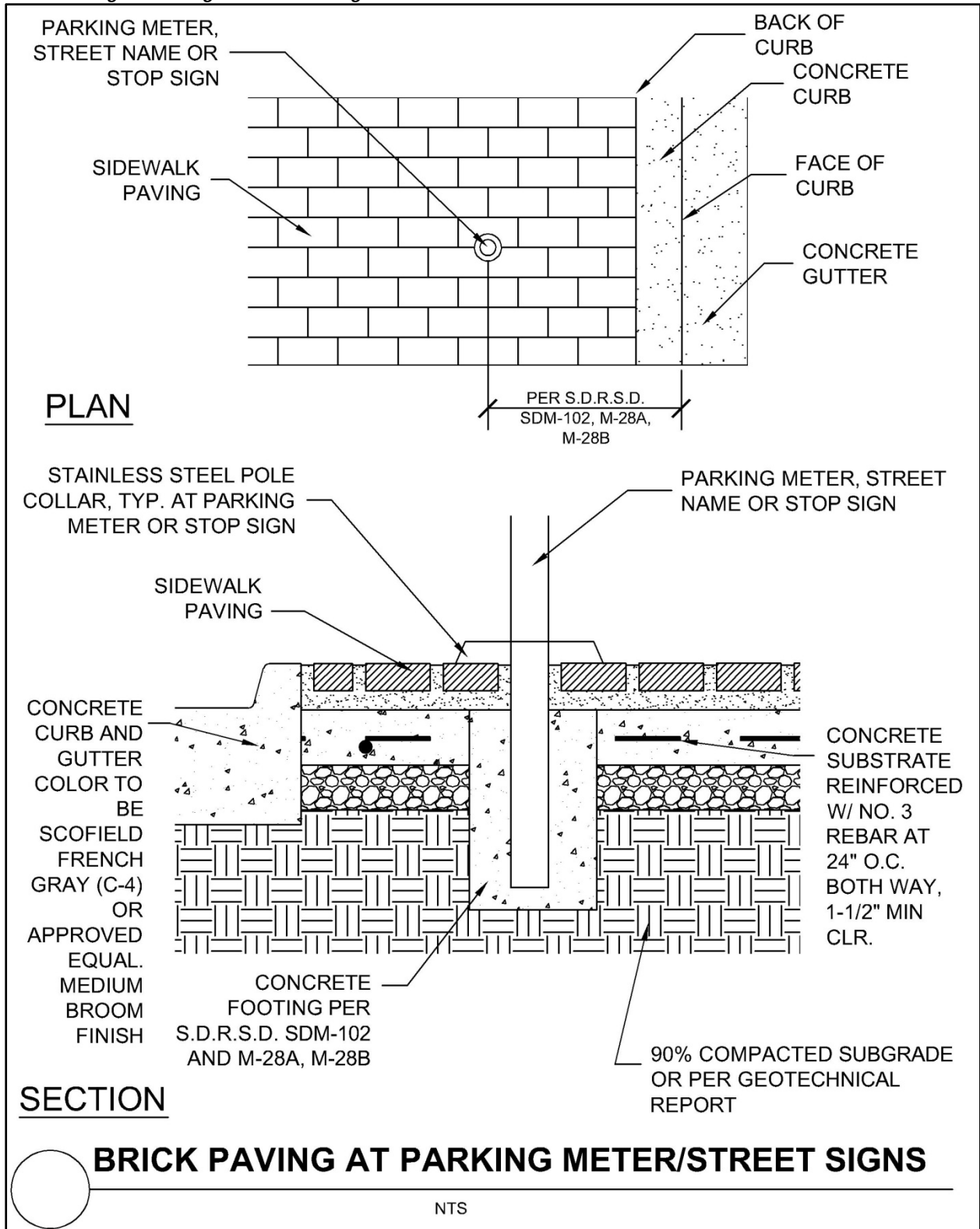

# REVISED DRAFT

This Document is a draft pending final approval. Please contact a CCDC Planner @ (619) 235-2200 to discuss your project.

## Concrete Paving with Expansion Joint

**NOTES:**

1. INSTALL DOWELED EXPANSION JOINT BETWEEN SEPERATE CONCRETE POURS.
2. CONTRACTOR MAY SUBMIT ALTERNATIVE METHODS TO SLIP DOWEL TO PREVENT LONG TERM VERTICAL MOVEMENT AT COLD/EXPANION JOINTS

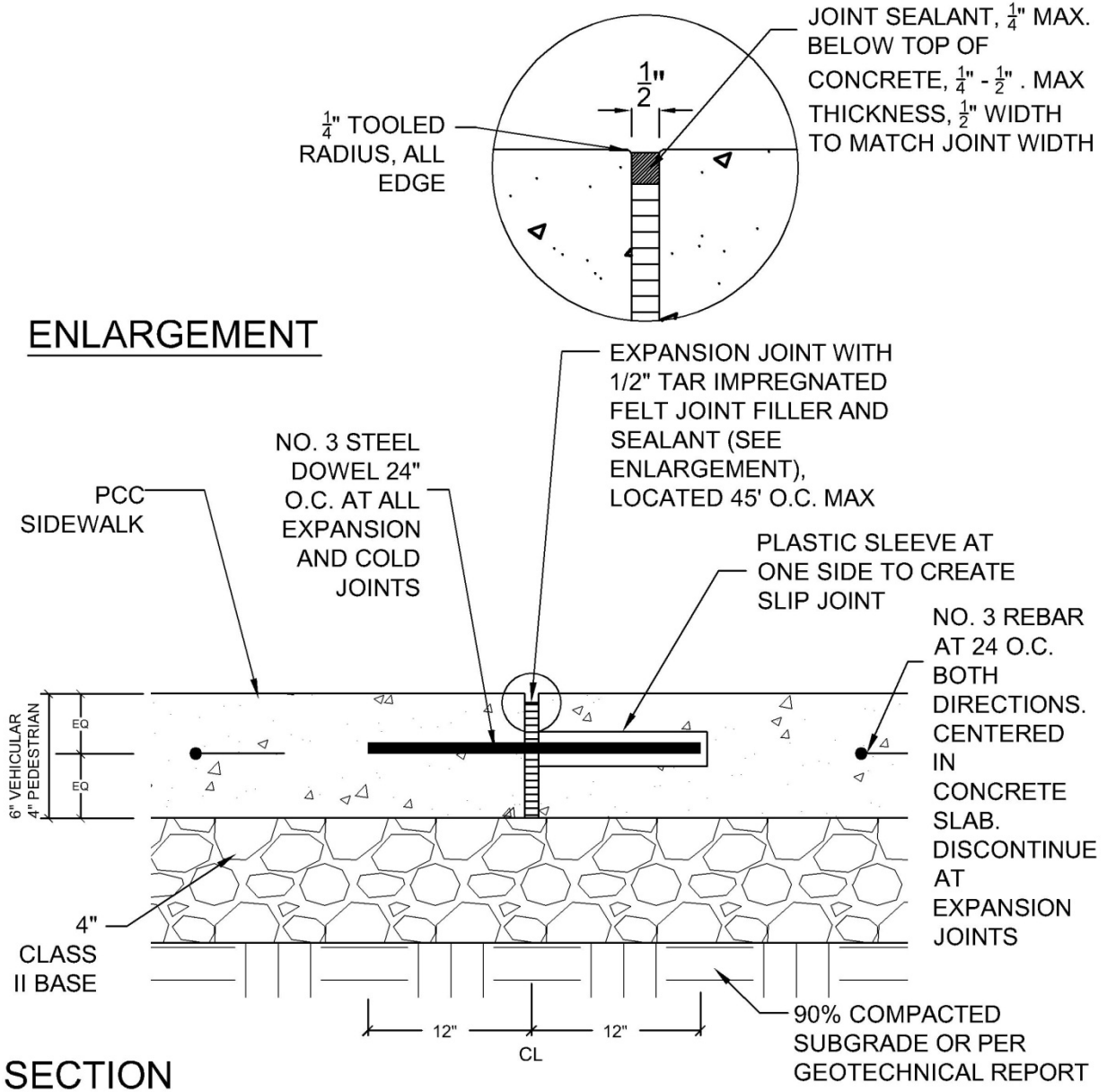

**ENLARGEMENT**

**SECTION**

**CONCRETE PAVING W/ EXPANSION JOINT**  
NTS

# REVISED DRAFT

This Document is a draft pending final approval. Please contact a CCDC Planner @ (619) 235-2200 to discuss your project.

## Interlocking Pavers

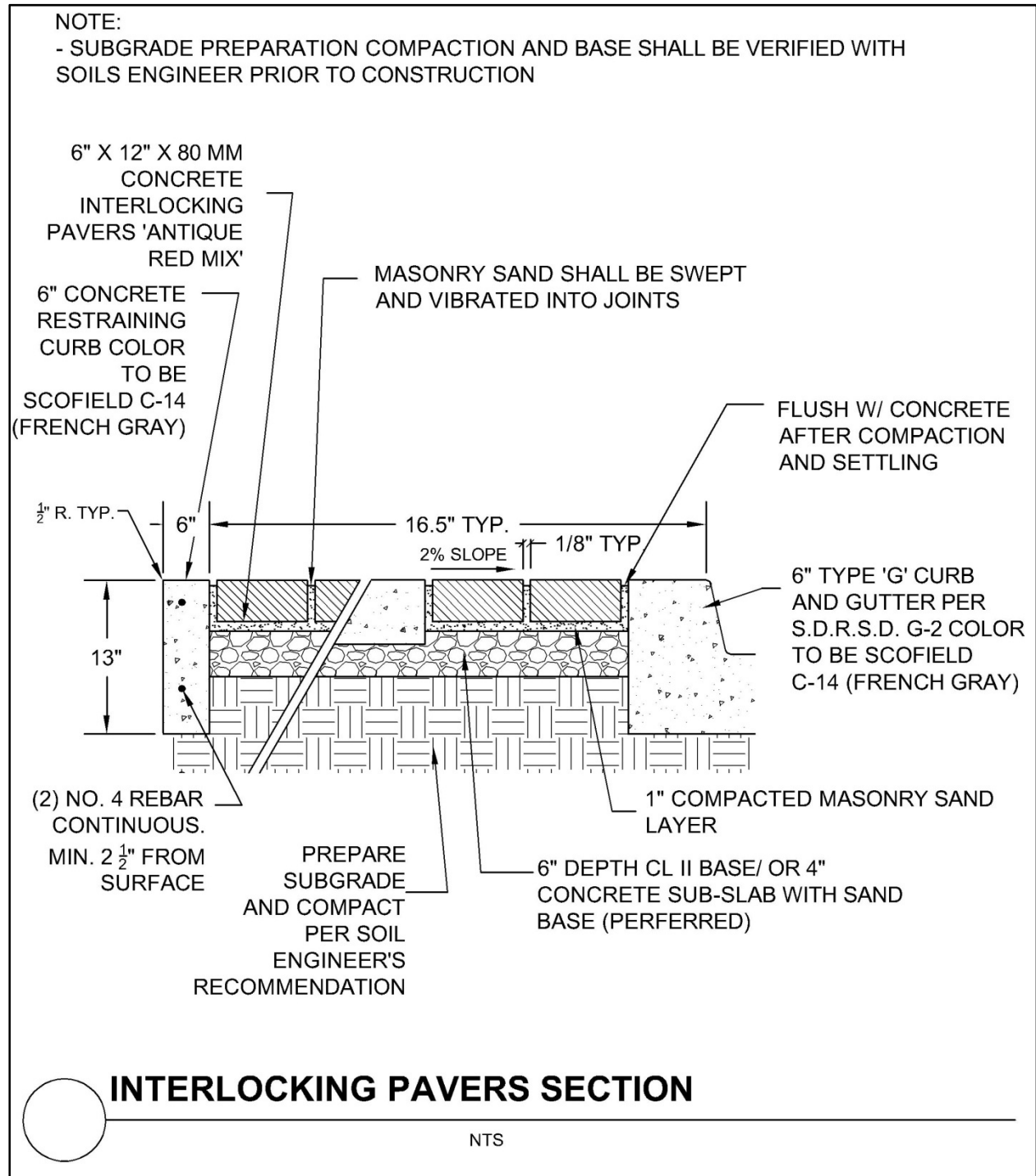



# REVISED DRAFT

This Document is a draft pending final approval. Please contact a CCDC Planner @ (619) 235-2200 to discuss your project.

## Planting

### Tree Well Detail

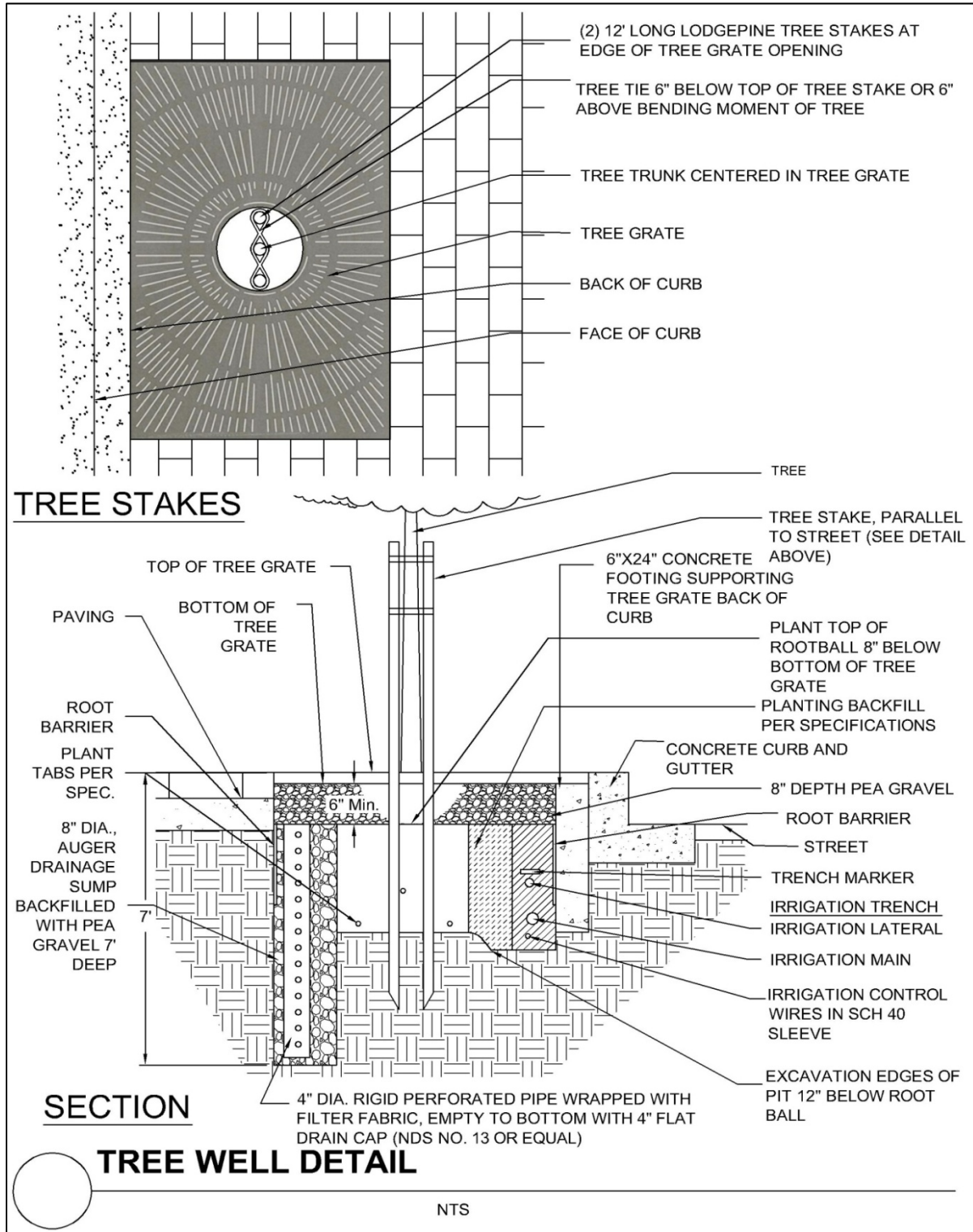

# REVISED DRAFT

This Document is a draft pending final approval. Please contact a CCDC Planner @ (619) 235-2200 to discuss your project.

## Root Barrier Installation

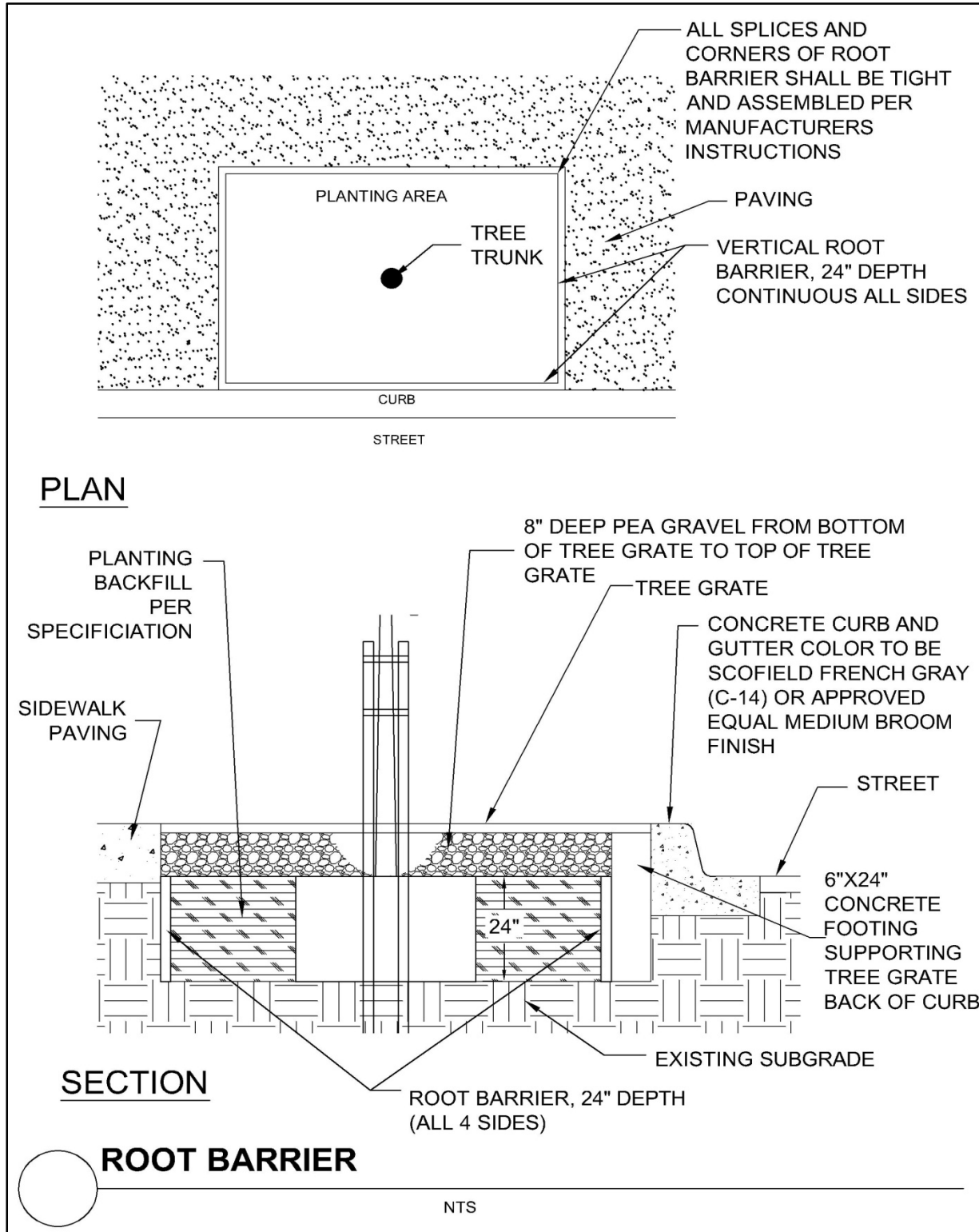

# REVISED DRAFT

This Document is a draft pending final approval. Please contact a CCDC Planner @ (619) 235-2200 to discuss your project.

## Tree Well Installation

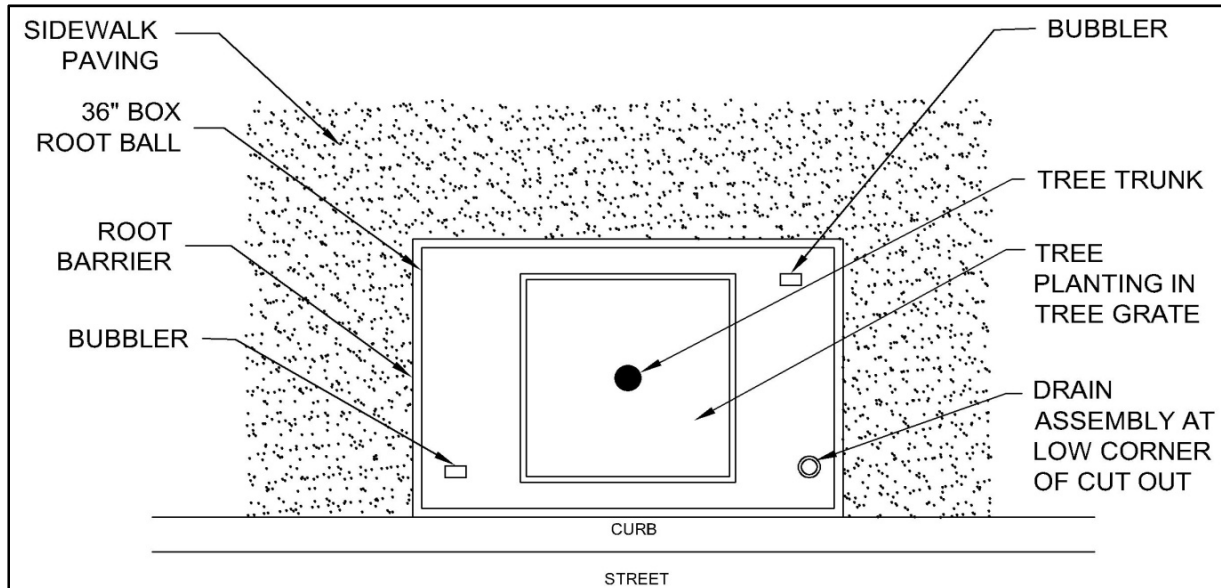

### PLAN

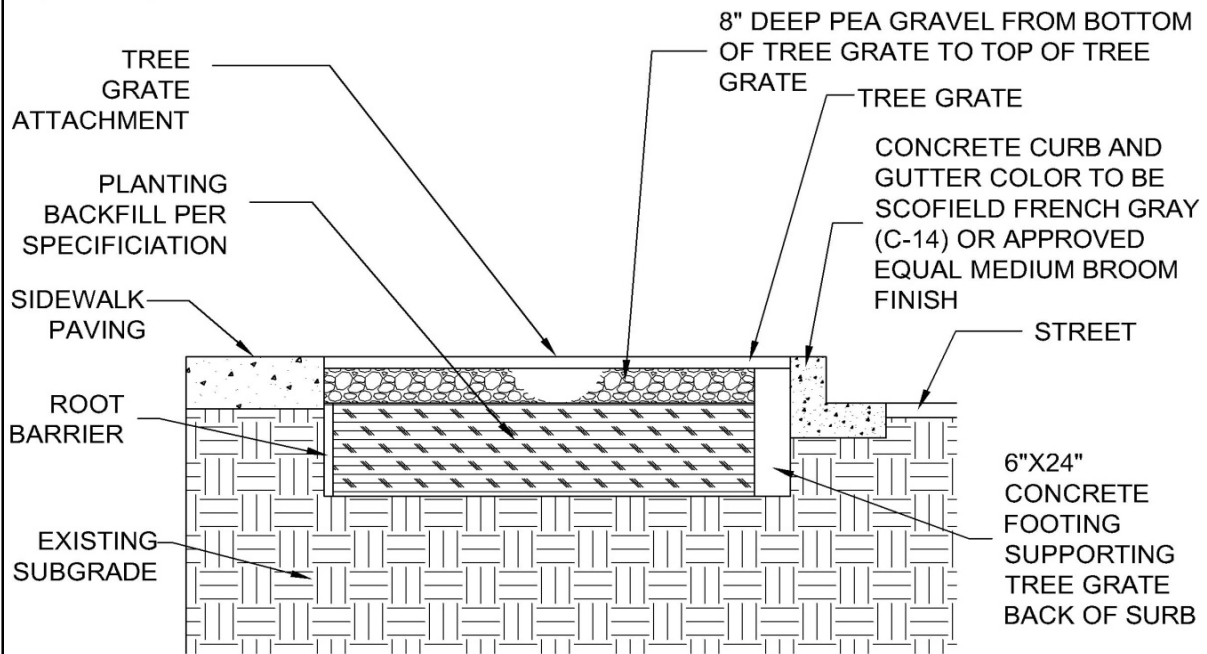

### SECTION

NOTE:  
SEE NEXT FIGURE FOR FRAME DETAILS

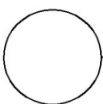

## TREE WELL INSTALLATION

NTS

# REVISED DRAFT

This Document is a draft pending final approval. Please contact a CCDC Planner @ (619) 235-2200 to discuss your project.

## Tree Well Framework

60 3/4" O.D.  
60 3/4" I.D.

1/4"

A

B

60 3/4" O.D.  
60 3/4" I.D.

REMOVEABLE SUPPORT CHANNEL

#4 REBAR ANCHOR (TYP)

1" X 1" X 1/4" ANGLE (TYP)

1" X 1" X 1" SQ BAR LUG (TYP)

REV	DESCRIPTION	APP	DATE

NOTES:

- ORDER 1 EA. SBF ID# D00BD "BOLT DOWN KIT" FOR EVERY 5 TREE GRATE FRAMES TO BE INSTALLED. (EACH KIT INCLUDES #7 DRILL BIT, T-30 TORX® DRIVER BIT, AND 20 TORX® 1/4" X 1-1/2" SCREWS FOR 5 TREE GRATE FRAMES)
- INSTALLER TO DRILL FRAME AND BOLT DOWN BLOCK IN FIELD.

**STYLE CI**  
FOR NEW SLAB INSTALLATION

SECTION A-A

**BOLT DOWN**  
FOR ANTI-PILFER INSTALLATION

SECTION B-B

SALES DWG

PRODUCTION APPROVAL	NOMENCLATURE	TOLERANCES	<p><b>SOUTH BAY FOUNDRY</b> 9444 ABRAHAM SANTEE, CA 92071, USA.</p>				
APPROVAL STATUS	DATE	UNITS: INCHES					
APPROVED BY:	PROCESS: STEEL FAB	.XX= .06	<table border="1" style="width: 100%; border-collapse: collapse;"> <tr> <td style="width: 50%;">TITLE: 60" SQUARE CI STYLE TREE GRATE FRAME</td> <td style="width: 50%;">REV -</td> </tr> <tr> <td>I.D.# DTF6060-CI</td> <td>DATE: 6/18/2006 SHEET: 1 OF 1</td> </tr> </table>	TITLE: 60" SQUARE CI STYLE TREE GRATE FRAME	REV -	I.D.# DTF6060-CI	DATE: 6/18/2006 SHEET: 1 OF 1
TITLE: 60" SQUARE CI STYLE TREE GRATE FRAME	REV -						
I.D.# DTF6060-CI	DATE: 6/18/2006 SHEET: 1 OF 1						
	MATERIAL: ASTM A36	.XXX= .031					
	FINISH: PER CUST REQ	ANGLES= ±1°					
	WEIGHT:						

**TREE WELL FRAMEWORK**

NTS

# REVISED DRAFT

This Document is a draft pending final approval. Please contact a CCDC Planner @ (619) 235-2200 to discuss your project.

## Tree Grate Attachment in Brick Paving

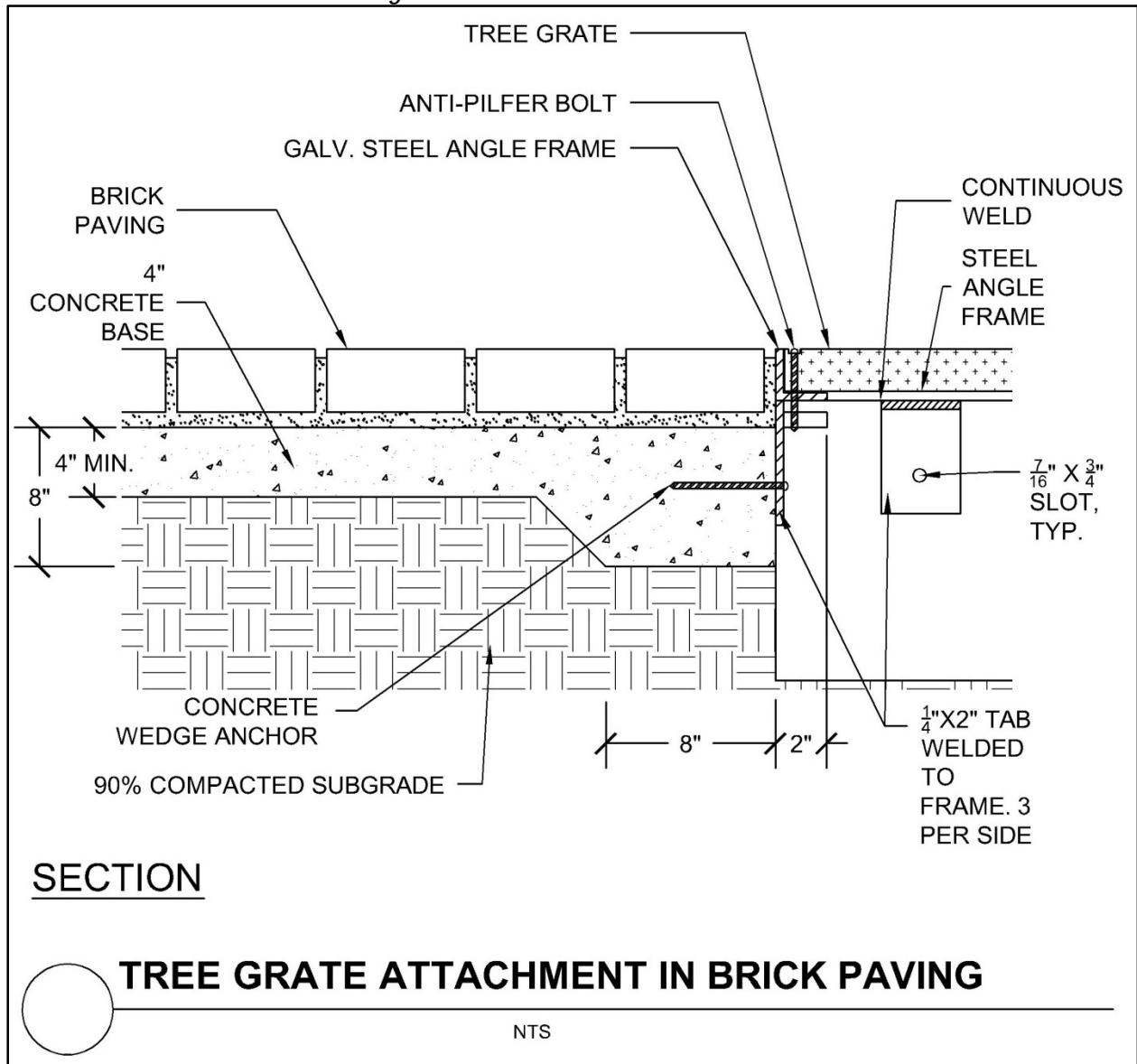

# REVISED DRAFT

This Document is a draft pending final approval. Please contact a CCDC Planner @ (619) 235-2200 to discuss your project.

## Tree Grate Attachment in Concrete

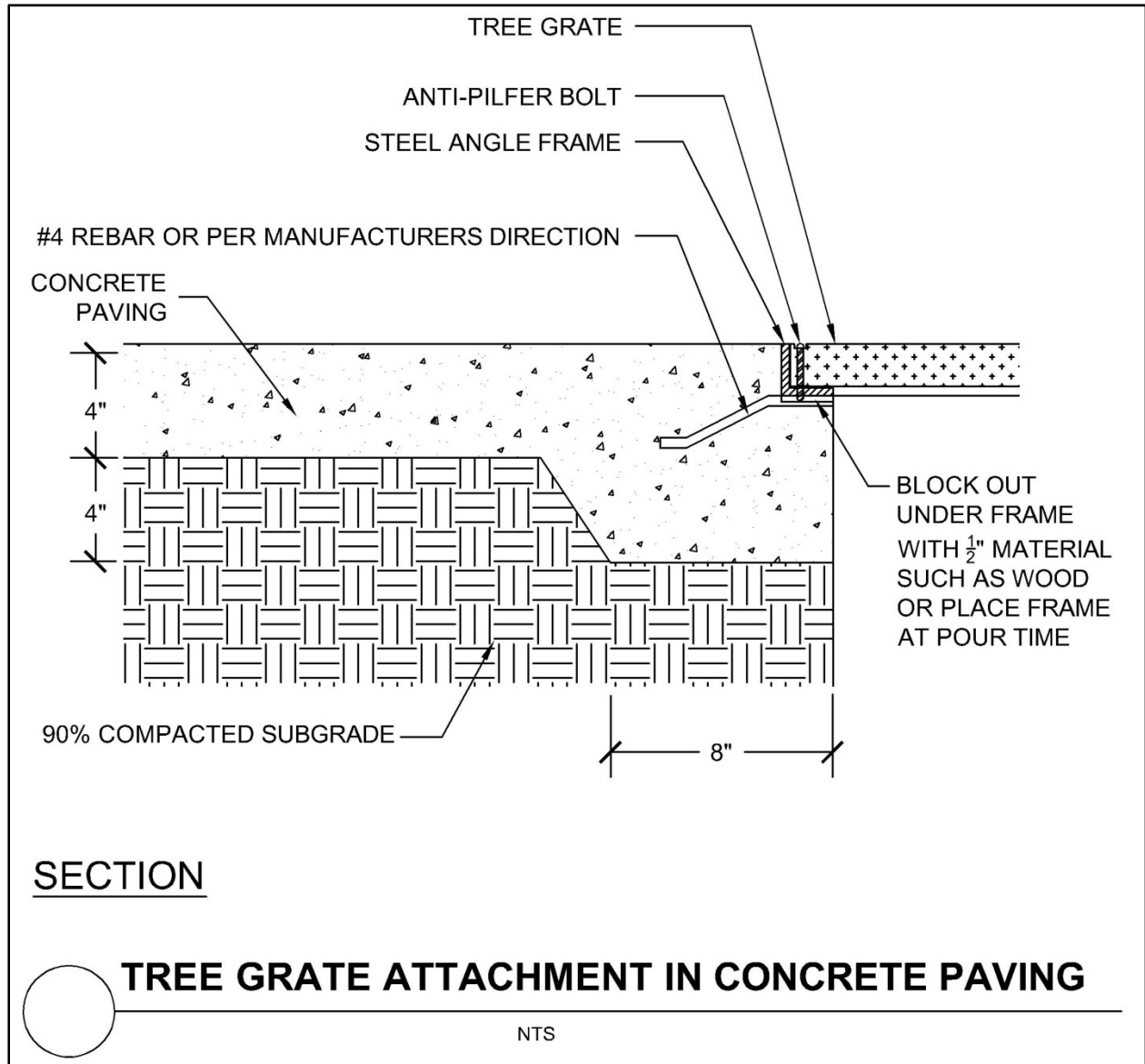



# REVISED DRAFT

This Document is a draft pending final approval. Please contact a CCDC Planner @ (619) 235-2200 to discuss your project.

## IRRIGATION DETAILS

### *Reduced Pressure Backflow Prevention Assembly*

**NOTES:**

1. ALL RISERS, UNIONS, ELBOWS AND NIPPLES SHALL BE RED BRASS
2. CLOSE NIPPLES SHALL NOT BE USED.
3. TEFLON TAPE 3/4" WIDE SHALL BE USED ON ALL THREADED CONNECTIONS.
4. CONCRETE PAD SHALL BE 18" WIDE, MINIMUM.
5. BACKFLOW PREVENTER ASSEMBLY SHALL BE TESTED UPON INSTALLATION BY A CERTIFIED BACKFLOW DEVICE TESTER. CONTRACTOR SHALL PROVIDE THE ENGINEER WITH WRITTEN TEST RESULTS COMPLETE BY CERTIFIED BACKFLOW TESTER PRIOR TO THE BACKFLOW PREVENTER ASSEMBLY'S ACCEPTANCE BY THE ENGINEER

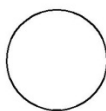
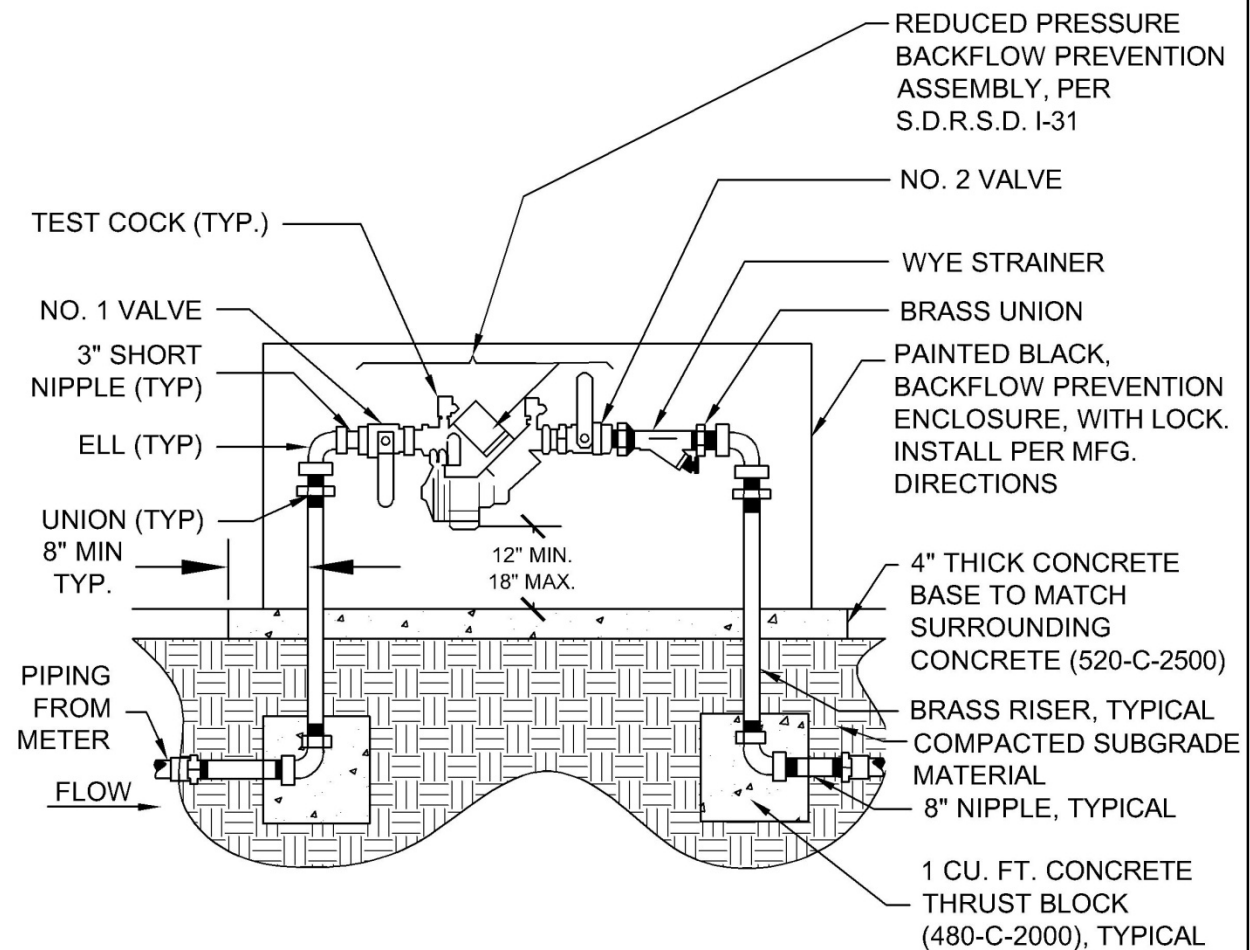

## **REDUCED PRESSURE BACKFLOW PREVENTION ASSEMBLY**

NTS

# REVISED DRAFT

This Document is a draft pending final approval. Please contact a CCDC Planner @ (619) 235-2200 to discuss your project.

## Globe Valve (Located in Paving Areas)

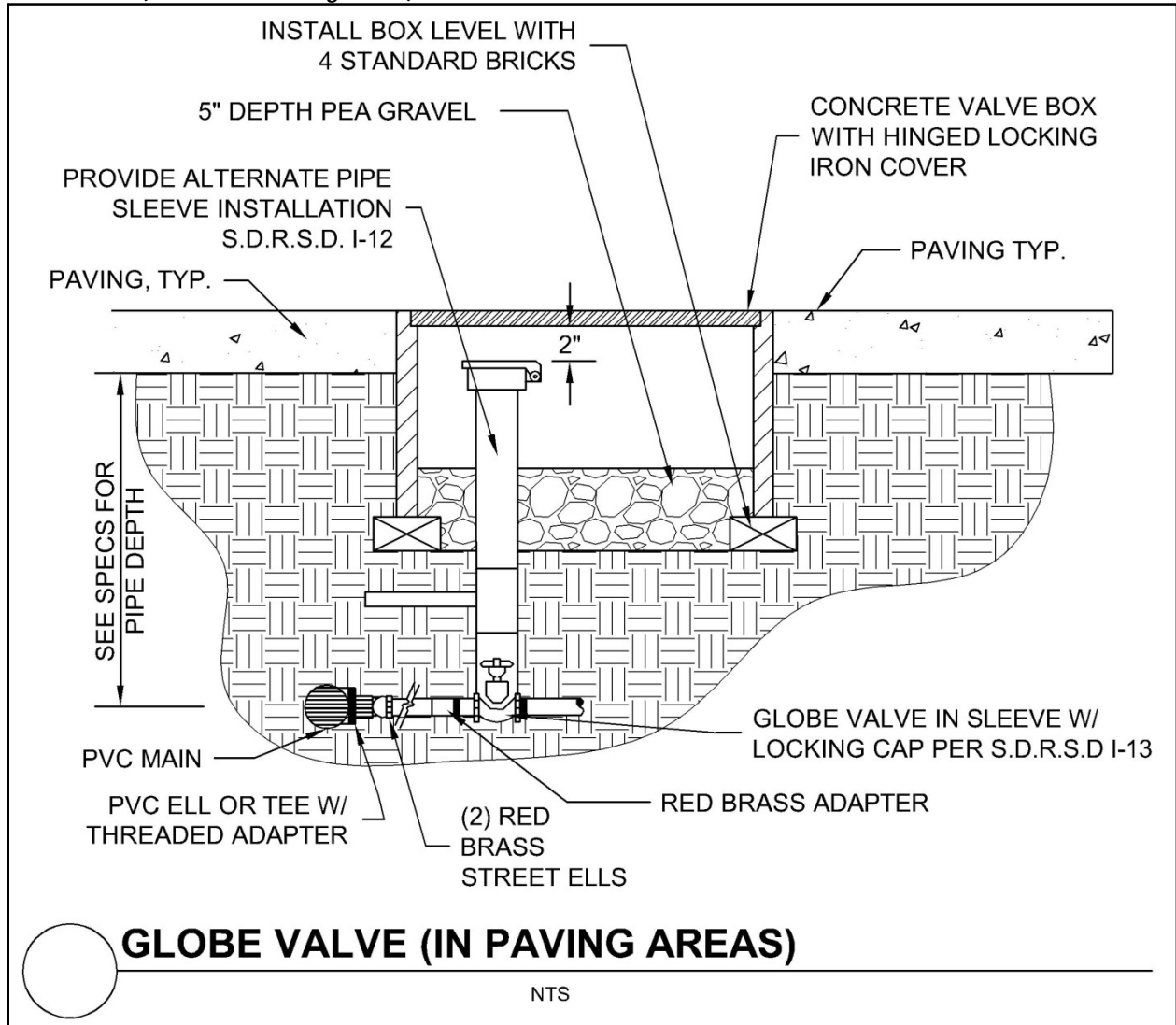

# REVISED DRAFT

This Document is a draft pending final approval. Please contact a CCDC Planner @ (619) 235-2200 to discuss your project.

## *Automatic Control Valve (Located in Paving Areas)*

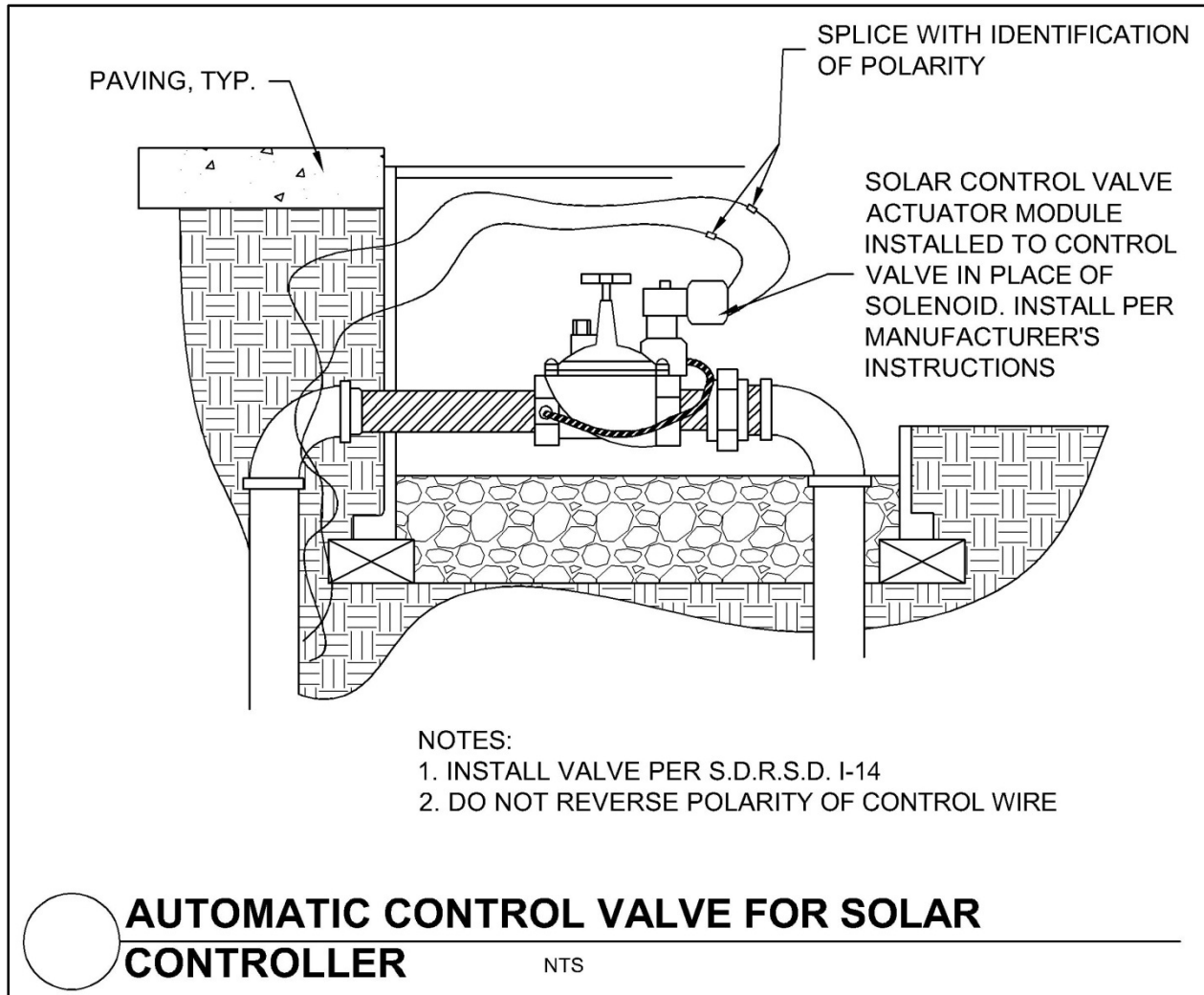

# REVISED DRAFT

This Document is a draft pending final approval. Please contact a CCDC Planner @ (619) 235-2200 to discuss your project.

## *Bubbler Heads At Tree Well*

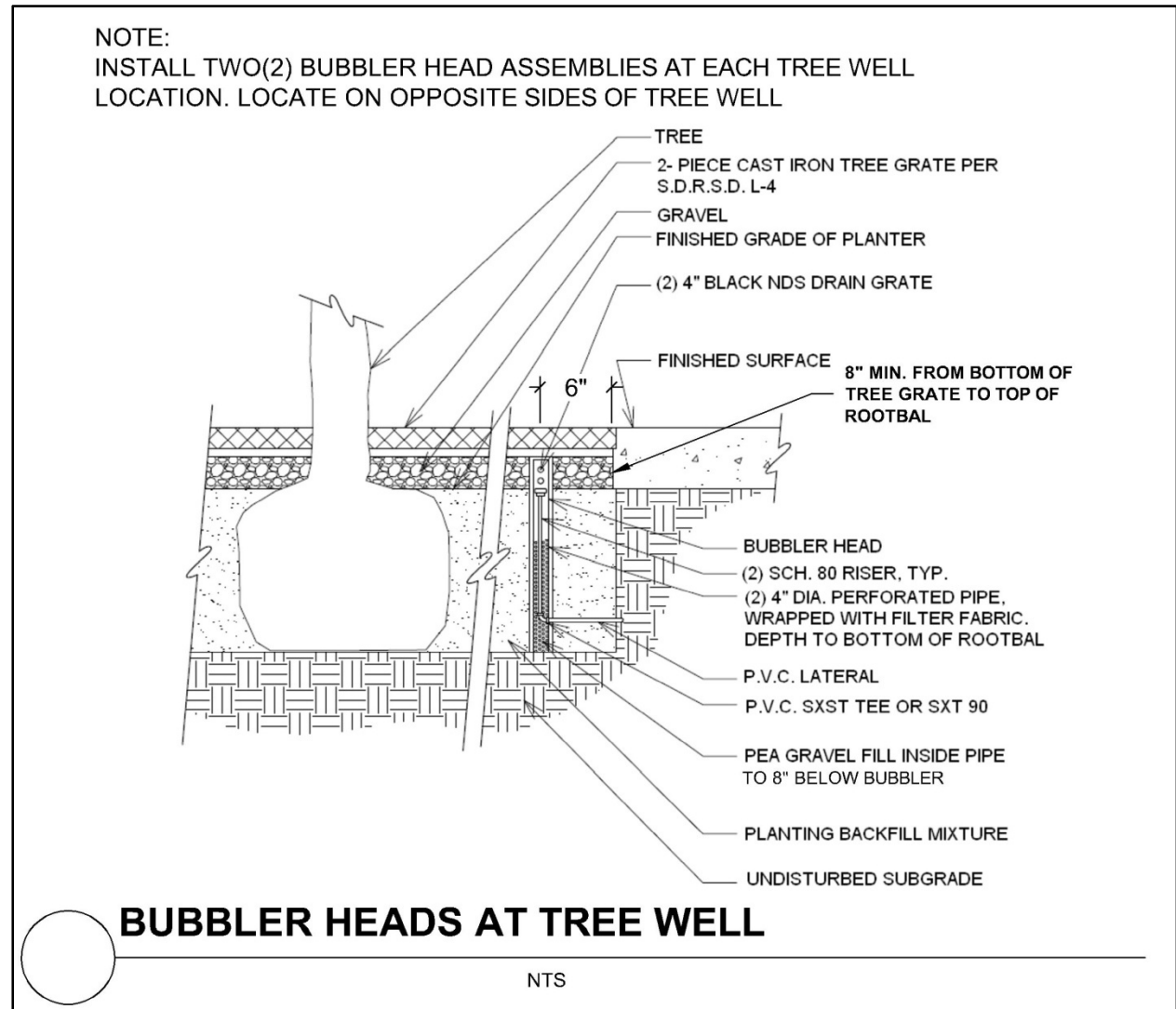

# REVISED DRAFT

This Document is a draft pending final approval. Please contact a CCDC Planner @ (619) 235-2200 to discuss your project.

## Quick Coupler Valve with Globe Valve (Located in Paving Areas)

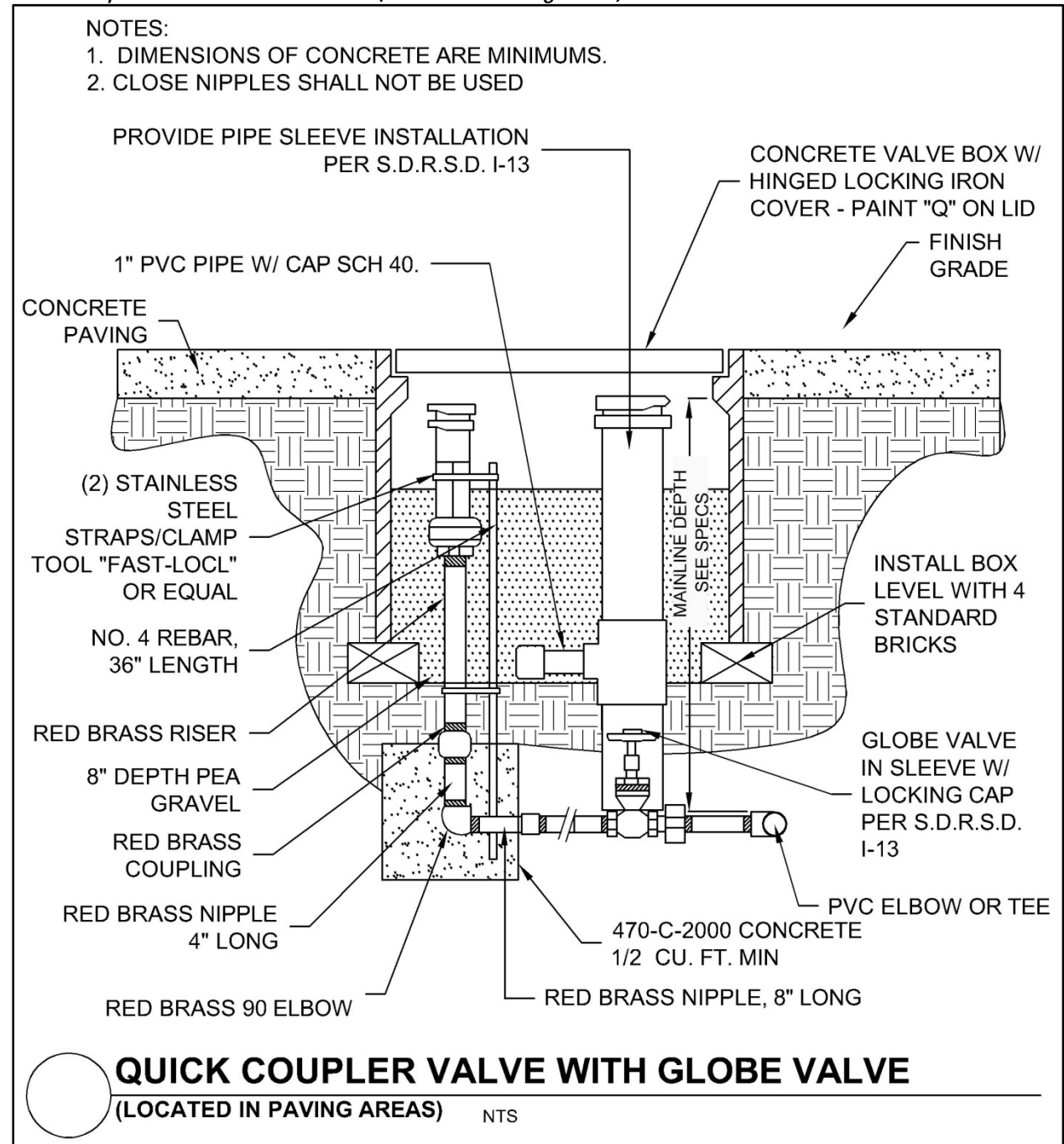

# REVISED DRAFT

This Document is a draft pending final approval. Please contact a CCDC Planner @ (619) 235-2200 to discuss your project.

This Page Intentionally left Blank



# REVISED DRAFT

This Document is a draft pending final approval. Please contact a CCDC Planner @ (619) 235-2200 to discuss your project.

## ***VIII. SPECIFICATION APPENDIX***

This Appendix is not a part of the adopted Manual; it is for reference only and may be updated by CCDC without requiring the Manual to be officially amended. Also, it is just a general guide for consultant use, as structural soil specifications should be modified for each project site.

### **Structural Soil**

This section describes the specification and mixing of a gap-graded material targeted to conform to a GP-GM material as defined by the Unified Soil Classification system with a minimum California Bearing Ratio exceeding 50 when properly compacted.

The intent is to form a two phase system a rigid, high-bearing capacity stone skeleton and a viable rooting zone for planted material suspended within the voids of the stone skeleton. This is achieved by mixing an angular stone of known size and shape with a soil predominately passing #200 sieve. The object is to minimize or eliminate all size fractions between 0.75 inches and medium sand, 0.16 in. as defined by the USDA soil classification system.

The material is designed to function as a sub-base material under pedestrian traffic or light vehicular traffic with the ability to withstand loading of emergency and/or maintenance vehicles. Its intended purpose is for establishing trees in areas where the tree is totally surrounded by pavement and space limitations or other factors preclude the use of non-paved trees or large tree planting containerized areas.

#### Part1 General

##### 1.01 Scope of Work

The work of this section consists of all structural soil work and related items as indicated on the Drawings or as specified herein and includes, but is not limited to, the following:

- A. Structural Soil shall be CU Soil by Amereq Inc. or approved equal.

##### 1.02 References and Standards

The following references are used herein and shall mean:

ASTM: American Society of Testing Materials.

USDA: United States Department of Agriculture.

AASHTO: American Association of State Highway and Transportation Officials.

Standard Specifications: "Green book" Standard Specifications for Public Works Construction

AOAC: Association of Official Agricultural Chemists.

##### 1.03 Samples and Submittals

- A. At least thirty (30) days prior to ordering materials, the Contractor shall submit to the Resident Engineer samples, certificates, manufacturer's literature and certified tests for materials specified

# REVISED DRAFT

This Document is a draft pending final approval. Please contact a CCDC Planner @ (619) 235-2200 to discuss your project.

below. No materials shall be ordered until the required samples, certificates, manufacturer's literature and test results have been reviewed and approved by the Resident Engineer. Delivered materials shall closely match the approved samples. Approval shall not constitute final acceptance. The Resident Engineer reserves the right to reject, on or after delivery, any material that does not meet these specifications.

- B. Submit two (2) one-half cubic foot representative sample of Clayton loam and two (2) two cubic foot representative samples Structural Soil mixes in this section for testing, analysis and approval. Submit one set of samples for every 500 CY of material to be delivered. In the event of multiple source fields for Clay Loam, submit a minimum of one set of samples per source field or stockpile. Samples shall be taken randomly throughout the field or stockpile at locations as directed by the Resident Engineer and packaged in the same presence of the resident engineer. Contractor shall deliver all the samples to testing laboratories and shall have the test results sent directly to the Resident Engineer. Samples shall be labeled to include the location of the source of the material, the date of the sample and the contractor's name. One of the two samples is to be used by the laboratory for testing purposes. The second sample of all Clay Loam and Structural Soil shall be submitted to the Resident Engineer at the same time as test analysis as a record of the soil color and texture.
  1. Submit the locations of all source fields for Clay Loam.
  2. Submit a list of all chemicals and herbicides applied to the Clay Loam for the last five years and a list of all crops grown in the Clay Loam source fields for the last three years.
- C. Submit soil test analysis reports from each sample of Clay Loam and Structural Soil from an approved soil testing laboratory. The test results shall report the following:
  1. The soil testing laboratory shall be approved by the Resident Engineer. The testing laboratory for particle size and chemical analysis may be a public agricultural extension service agency or agricultural experiment station.
  2. Submit a bulk density of the sample and a particle size analysis including the following gradient of mineral content:

USDA Designation Size in mm.  
Gravel +2 mm  
Sand 0.05 -2 mm  
Silt 0.002-0.05 mm  
Clay minus 0.002 mm

Sieve analysis shall be performed and compared to USDA Soil Classification System. Sieve analysis shall be done by a combined hydrometer and wet sieving using sodium hexametaphosphate as a dispersant in compliance with ASTM D422 after destruction of organic matter by hydrogen peroxide.
  3. Submit a chemical analysis, performed in accordance with current AOAC Standards, including the following:
    - a. pH and Buffer pH.

# REVISED DRAFT

This Document is a draft pending final approval. Please contact a CCDC Planner @ (619) 235-2200 to discuss your project.

- b. Percent organic matter as determined by the loss on ignition of oven-dried samples. Test samples shall be oven-dried to a constant weight at a temperature of 230 degrees F, plus or minus 9 degrees.
  - c. Analysis of nutrient levels by parts per million including nitrate nitrogen, ammonium nitrogen, phosphorus, potassium, magnesium, manganese, iron, zinc, calcium and extractable aluminum. Nutrient test shall include the testing laboratory recommendations for supplemental additions to the soil as calculated by the amount of material to be added per volume.
  - d. Analysis for levels of toxic elements and compounds including arsenic, boron, cadmium, chromium, copper, lead mercury, molybdenum, nickel, zinc and PCB. Test results shall be cited in milligrams per kilogram.
  - e. Soluble salt by electrical conductivity of a 1:2 soil/water sample measured in Milliohm per cm.
  - f. Cation Exchange Capacity (CEC).
  - g. Carbon/Nitrogen Ratio.
4. Submit 5-point minimum moisture density cure AASHTO T 99 test results for each Structural Soil sample without removing oversized aggregate.
  5. Submit California Bearing Ratio test results for each Structural Soil sample compacted to peak standard density. The soaked CBR shall equal or exceed a value of 50.
  6. Submit measured dry-weight percentage of stone in the mixture.
  7. The approved Structural Soil samples shall be the standard for each lot of 500 cubic yards of material.
  8. All testing and analysis shall be at the expense of the Contractor.
- D. Maintenance instructions: Prior to the time of Final Acceptance of the Work, submit maintenance instructions for the use, removal and replacement of Structural soil for the Owner's use. The instructions shall be reviewed by the Resident Engineer as a precondition for Final Acceptance of the Work.
- E. Submit to the Resident Engineer for review a proposed plan and vertical section layout of all Structural Soil.
- F. Submit one cubic foot sample per each 500 cubic yards of required material, and of each sample, the following analysis for all Crushed Stone. The soil testing laboratory shall be approved by the Resident Engineer.
1. Provide a particle size analysis including the following gradient of material content:

# REVISED DRAFT

This Document is a draft pending final approval. Please contact a CCDC Planner @ (619) 235-2200 to discuss your project.

## USDA Designation Size in mm.

3 2 +76mm  
2-1/2 @ 63-76mm  
2 @ 50-63mm  
1-1/2 @ 37-50mm  
1 @ 25-37mm  
3/4 @ 19-25mm  
Fine gravel 2-19 mm  
Sand 0.05-2 mm  
Silt 0.002-0.05 mm  
Clay minus 0.002 mm

2. Provide the manufacturer's analysis of the following:
  - a. Loose and rodded unit weight.
  - b. Bulk specific gravity and absorbency.
  - c. Stone dimension and surface texture description.
  - d. Documentation of acceptance for use as DOT approved aggregate by the appropriate regional DOT.

3. Provide a percentage pore space analysis defined as follows:

$(1\text{-Rodded Unit Weight divided by the Bulk Specific Gravity}) \times 100$

- G. Submit one pound sample of each type of fertilizer and 3 certificates showing composition and analysis. Submit the purchasing receipt for each fertilizer showing the total quantity purchased for the project prior to installation.
- H. Submit the Landscape or Pavement Material Contractor's qualifications outlining projects or similar quality, schedule requirements and construction detailing over the last five years. Qualifications shall include: The names of all similar projects, year completed, location, description of scope of work including the types and quantities of planting mix/pavements material installed and the name, address and telephone number of the owner or the owner's representative.

## 1.04 Delivery, Storage, and Handling

- A. Do not deliver or place soils in frozen, wet, or muddy condition. Material shall be delivered at or near optimum compaction moisture content as determined by AASHTO T 99 (ASTM D 698). Do not deliver or place materials in an excessively moist condition (beyond 2 percent above optimum compaction moisture content as determined by AASHTO T 99 (ASTM D 698)).
- B. Protect soils and mixes from absorbing excess water and from erosion at all times. Do not store materials unprotected from large rainfall events. Do not allow excess water to enter site prior to compaction. If water is introduced into material after grading, allowing material to drain or aerate to optimum compaction moisture content.

# REVISED DRAFT

This Document is a draft pending final approval. Please contact a CCDC Planner @ (619) 235-2200 to discuss your project.

## 1.05 Examination of Conditions

- A. All areas to receive Structural Soil shall be inspected by the Contractor before starting work and all defects such as incorrect grading, compaction and inadequate drainage etc. shall be reported to the Resident Engineer prior to beginning this work.
- B. The Contractor shall be responsible for judging the full extent of work requirements involved, including, but not limited to, the potential need for temporary storage and staging of soils, including moving soil stick piles at the site to accommodate scheduling of other work and the need to protect installed soils from compaction, erosion and contamination.

## 1.06 Quality Assurance

- A. Qualifications of Landscape or pavement material Contractors: The work of this section shall be performed by a Landscape Contracting firm which has a minimum of five years experience successfully installing planting mixes or pavement materials of a similar quality, schedule requirement and construction detailing to this project. Proof of this experience shall be submitted as per paragraph, SAMPLES AND SUBMITTALS, of this Section.

# REVISED DRAFT

This Document is a draft pending final approval. Please contact a CCDC Planner @ (619) 235-2200 to discuss your project.

## Part 2 Materials

### 2.01 Clay Loam

A. Clay Loam shall be a "clay loam" based on the "USDA classification system" as determined by mechanical analysis (ASTM D-422) and it shall be of uniform composition, without admixtures of subsoil. It shall be free of stones greater than one-half inch, lumps, plants and their roots, debris and other extraneous matter over one inch in diameter or excess of smaller pieces of the same materials as determined by the Resident Engineer. It shall not contain toxic substances harmful to plant growth. It shall be obtained from naturally well-drained area, which have never been stripped of top soil before and have a history of satisfactory vegetative growth. Clay Loam shall contain not less than two percent (2%) nor more than five percent (5%) organic matter as determined by the loss on ignition of oven-dried samples. Test samples shall be oven-dried to a constant weight at a temperature of 230 degrees F., plus or minus nine (9) degrees.

B. Mechanical analysis for a Loam/Clay Loam shall be as follows:

Textural Class % of total weight

Gravel less than 5%

Sand 20 – 45%

Silt 20 – 50%

Clay 20 – 40%

C. Chemical analysis: Meet or be amended to meet the following criteria.

1. pH between 5.5 to 6.5

2. Percent organic matter 2-5% by dry weight.

3. Nutrient levels as required by the testing laboratory recommendations for the type of plants to be grown in the soil.

4. Toxic elements and compounds below United States Environmental protection Agency Standards for Exceptional Quality sludge or local standard, whichever is more stringent.

5. Soluble slat less than 1.0 Milliohm per cm.

6. Cation Exchange Capacity (CEC) greater than ten (10).

7. Carbon/Nitrogen Ratio less than 33:1.

D. Clay Loam shall be the product of a commercial processing facility specializing in production of stripped natural topsoil. No topsoil shall come from USDA-classified prime farmland.



# REVISED DRAFT

This Document is a draft pending final approval. Please contact a CCDC Planner @ (619) 235-2200 to discuss your project.

## 2.02 Fertilizer (if needed)

- A. Commercial fertilizer complying with State and United States fertilizer laws. Deliver fertilizer in original unopened containers, which shall bear the manufacturer's certificate of compliance covering analysis, which shall be furnished to the Resident Engineer. Fertilizer shall be formulated for mixing into the soil and be certified by the manufacturer to provide controlled release of nitrogen continuously from a period of no less than nine (9) months and no more than twelve (12) months.
- B. Fertilizer percentages of weight of ingredients and application rates shall be as recommended by the soil testing results.

## 2.03 Sulfur (if needed)

- A. Sulfur shall be commercial granular, ninety-six percent (96%) pure sulfur, delivered in containers with the name of the manufacturer, material and analysis appearing in the container
- B. Sulfur used to lower soil pH but remaining above six point five (6.5) shall be ferrous sulfate formulation.

## 2.04 Lime (if needed)

- A. Agricultural limestone containing a minimum of eighty-five percent (85%) carbonates. Minimum gradation: one hundred percent (100%) passing ten (10) mesh sieve; ninety-eight percent (98%) passing twenty (20) mesh sieve; fifty-five percent (55%) passing sixty (60) mesh sieve and forty percent (40%) passing one-hundred (100) mesh sieve.

## 2.05 Crushed Stone

- A. Crushed Stone shall be a DOT certified crushed stone. A non-limestone aggregate will be preferred. The maximum allowable aggregate able to pass the half (½) inch sieve is ten (10) percent. A ratio of normal maximum to nominal minimum particle size shall be 2:1.
- B. Acceptable aggregate dimensions will not exceed 2.5:1.0 for any two dimensions chosen.
- C. Minimum of ninety percent (90%) with one fractured face, minimum seventy-five percent (75%) with two (2) or more fractured faces.
- D. Results of Aggregate Soundness Loss test shall not exceed eighteen percent(18%).
- E. Losses from LA Abrasion tests shall not exceed forty percent (40%).

## 2.06 Hydrogel

- A. Hydrogel shall be a potassium propionate - propenamide copolymer Hydrogel as manufactured by Gelscape by Amereq Corporation (800) 832-8788 or approved equal.

# REVISED DRAFT

This Document is a draft pending final approval. Please contact a CCDC Planner @ (619) 235-2200 to discuss your project.

## 2.07 Water

- A. The Contractor shall be responsible to furnish his own supply of water to the site at no extra cost. All work that is injured or damaged due to the lack of water or the use of too much water shall be the contractor's responsibility to repair or replace in-kind material. Water shall be free from impurities which may damage vegetation.

## 2.08 Structural Soil

- A. A uniformly blended mixture of Crushed Stone, Clay Loam and Hydrogel, mixed to the following proportion:

### MATERIAL UNIT OF WEIGHT

Crushed Stone 100 units dry weight

Loam (dry) (Approx. 20) determined by the test of the mix.

Hydrogel 0.03 units dry weight

Total moisture (AASHTO T-99 optimum moisture)

- B. The initial mix design for testing shall be determined by adjusting the ratio between the Crushed Stone and the Clay Loam. Adjust final mix dry weight mixing portion to decrease soil in mixture if CBR test results fail to meet acceptance (CBR #50).

## Part 3 Construction Methods

### 3.01 Mix Design

- A. Prepare sample Structural Soil mixes to determine the ratio of mix components. Submit for approval.
  - 1. Submit samples and the test results of each mix component for approval. Based on samples and the analysis of the mix components, the Resident Engineer and the Contractor will jointly determine a mix ratio for each Clay Loam or Crushed Stone where the testing indicates a significant difference in physical analysis of the Clay Loam or Crushed Stone as determined by the Resident Engineer.
  - 2. The Contractor shall prepare the samples of the proposed mix ratio options and obtain soil test as described in paragraph 1.04 C. Submit the samples of each of the mixes with the test results.
  - 3. The Resident Engineer may request additional Structural Soil mix ratio samples to be tested in the event that further refinement of the mix is necessary.
  - 4. Submit to the Resident Engineer proposed fertility amendment recommendations including amounts and types of fertilizers and pH adjustments for each mix ratio. Fertility adjustments shall be included as part of the mixing process.

# REVISED DRAFT

This Document is a draft pending final approval. Please contact a CCDC Planner @ (619) 235-2200 to discuss your project.

## 3.02 Soil Mixing and Quality Control Testing

- A. All Structural Soil mixing shall be performed at the Contractor's yard using appropriate soil measuring, mixing and shredding equipment of sufficient capacity and capability to assure proper quality control and consistent mix ratios. No mixing of Structural Soil at project site shall be permitted. Portable pugging may be used.
  1. Maintain adequate moisture content during the mixing process. Soils and mix components shall easily shred and break down without clumping. Soil clods shall easily break down into a fine crumbly texture. Soils shall not be overly wet or dry. The contractor shall measure and monitor the amount of soil moisture at the mixing site periodically during the mixing process.
  2. A mixing procedure for front-end loader shall be as follows:
    - a. On a flat asphalt or concrete paved surface, spread an 8-inch to 12-inch layer of Crushed Stone.
    - b. Soread evenly over the stone the specified amount of dry hydrogel.
    - c. Spread over the dry hydrogel and Crushed Stone a proportional amount of Clay Loam according to the mix design.
    - d. Blend the entire amount by turning, using a front-end loader or other suitable equipment until a consistent blend is produced.
    - e. Add moisture gradually and evenly during the blending turning operation as required to achieve the required moisture content. Delay applications of moisture for 10 minutes prior to successive applications. Once established, mixing should produce a material one percent (1%) of the optimum moisture level for compaction.
  3. Pugging operation mixing procedure may also be as follows:
    - a. Feed a known weight of Crushed Stone into the mixing trough.
    - b. Add hydrogel as a slurry into trough and mix slurry and stone into a uniform blend.
    - c. Meter in soil in proper proportion of Clay Loam soil while stone-slurry mixture is in motion.
    - d. Add water to bring mixture to target moisture content after factoring in water from the slurry and the Clay Loam moisture.
    - e. Auger out to stockpile or transport vehicle (or into pit if using a portable pugging operation).

# REVISED DRAFT

This Document is a draft pending final approval. Please contact a CCDC Planner @ (619) 235-2200 to discuss your project.

4. Add soil amendments to alter soil fertility including fertilizers and pH adjustment at the time of mixing at the rates recommended by the soils test.
    - a. Soil pH shall be adjusted to fall with a value of 5.5 and 6.5 two months after mixing if the material is stored, unless mixing with a high pH stone. Once pavement is laid, no adjustment should be imposed.
    - b. Soil component Carbon/nitrogen ratio shall be adjusted to be less than 33:1 within two months after mixing.
  - B. The Contractor shall mix sufficient material in advance of the time needed at the job site to allow adequate time for final quality control testing as required by the progress of the work. Structural Soil shall be stored in piles of approximately 500 cubic yards and each pile shall be protected from rain and erosion by covering with plastic sheeting.
  - C. During the mixing process, the Contractor shall take two (2) one cubic foot quality control samples per 500 cubic yards of production from the final Structural Soil. The samples shall be taken from random locations in the numbered stockpiles as required by paragraph 1.03.B of this specification. Each sample shall be tested for particle size analysis and chemical analysis as described in Paragraph 1.03 C.2 and 3 above. Submit the results directly to the Resident Engineer for review and approval.
  - D. The quality control sample Clay Loam – Crushed Stone ratio's shall be two percent (2%) of the approved test sample as determined by splitting a known weight of oven dried material on a #4 sieve. In the event that the quality control samples vary significantly from the approved Structural Soil sample (as determined by the Resident Engineer) remix and retest any samples that fail by making adjustments to the mixing ratios and procedures to achieve the approved consistency.
- 3.03 Underground Utilities and Subsurface Conditions
- A. Notify the Resident Engineer of any subsurface conditions, which will affect the Contractor's ability to complete the work.
  - B. Locate and confirm the location of all underground utility lines and structures prior to the start of any excavation.
  - C. Repair any underground utilities or foundations damaged by the Contractor during the progress of this work. The cost of all repairs shall be at the Contractor's expense.
- 3.04 Site Preparation
- A. Do not proceed with the installation of the Structural Soil material until all walls, curb footings and utility work in the area have been installed. For site elements dependent on Structural Soil for foundation support, postpone installation until immediately after the installation of Structural Soil.
  - B. Install subsurface drain lines as shown on the drawings prior to installation of Structural Soil material.

# REVISED DRAFT

This Document is a draft pending final approval. Please contact a CCDC Planner @ (619) 235-2200 to discuss your project.

- C. Excavate and compact the proposed sub-grade to depths, slopes and widths as shown on the drawings. Maintain all required angles of repose of the adjacent materials as shown on the drawings. Do not over-excavate compacted sub-grades of adjacent pavement or structures.
- D. Confirm that the sub-grade is at the proper elevation and compacted as required. Sub-grade elevations shall slope parallel to the finished grade and/or toward the subsurface drain lines as shown on the drawings.
- E. Clear all construction debris, trash, rubble, and any foreign material. In the event that fuels, oils, concrete washout silts or other material harmful to plants have been spilled into the sub-grade material, excavate the soil to remove sufficiently to remove the harmful material. Fill any over-excavation with approved fill and compact that the required sub-grade compaction.
- F. Do not proceed with the installation of Structural Soil until all utility work in the area has been installed. All subsurface drainage systems shall be operational prior to installation of Structural Soils.
- G. Protect adjacent walls, walks and utilities from damage or staining by the soil. Use ½ -inch plywood and or plastic sheeting as directed to cover existing concrete, metal and masonry work and other items as directed during the progress of the work.
- H. Clean up all trash and any soil or dirt spilled on any paved surface at the end of each working day.
- I. Any damage to the paving or architectural work caused by the soils installation Contractor shall be repaired by the general Contractor at the soils installation Contractor's expense. Maintain all silt and sediment control devices required by applicable regulations. Provide adequate methods to assure that trucks and other equipment do not track soil from the site onto adjacent property and the public right-of-way.

## 3.05 Installation of Structural Soil Materials

- A. Install Structural Soil in six (6) inch lifts and compact each lift.
- B. Compact all materials to peak dry density from standard AASHTO compaction curve (AASHTO T 99). No compaction shall occur when moisture content exceeds maximum as listed herein. Delay compaction twenty-four (24) hours if moisture content exceed maximum allowable and protect Structural Soil during delay in compaction with plastic or plywood as directed by the Resident Engineer.
- C. Bring Structural soils to finished grades as shown on the drawings. Immediately protect the Structural Soil material from contamination by toxic materials, trash, debris, water containing cement, clay, silt or materials that will alter the particle size distribution of the mix with plastic or plywood as directed by the Resident Engineer
- D. The Resident Engineer may periodically check the material being delivered and installed at the site for color and texture consistency with the approved sample provided by the Contractor as part of the submittal for Structural soil. In the event that the installed material varies significantly from the approved sample, the Resident Engineer may request that the Contractor test the installed Structural Soil. Any soil which varies significantly from the approved testing results, as determined

# REVISED DRAFT

This Document is a draft pending final approval. Please contact a CCDC Planner @ (619) 235-2200 to discuss your project.

by the Resident Engineer, shall be removed and new Structural Soil installed that meets these specifications.

## 3.06 Fine Grading

- A. After the initial placement and rough grading of the Structural Soil but prior to the start of fine grading, the Contractor shall request review of the rough grading by the Resident Engineer. The contractor shall set sufficient grade stakes for checking the finished grades.
- B. Adjust the finish grades to meet field conditions as directed.
  - 1. Provide smooth transitions between slopes of different gradients and direction.
  - 2. Fill dips and remove any bumps in the overall plane slope.
    - a. The tolerance for dips and bumps in Structural Soil areas shall be a three (3) inch deviation from the plane ten (10").
  - 3. All fine grading shall be inspected and approved by the Resident Engineer prior to the installation of other items to be placed on the Structural Soil.
- C. The Resident Engineer will inspect the work upon the request of the Contractor. Request for inspection shall be received by the Resident Engineer at least ten (10) days before the anticipated date of inspection.

## 3.07 Acceptance Standards

- A. The Resident Engineer will inspect the work upon request of the Contractor. Request for inspection shall be received by the Resident Engineer at least ten (10) days before the anticipated date of inspection.

## 3.08 Clean Up

- A. Upon completion of the Structural Soil installation operations, clean areas within the contract limits. Remove all excess fills, soils and mix stockpiles and legally dispose of all waste materials, trash and debris. Remove all tools and equipment and provide a clean, clear site. Sweep, do not wash, all paving and other exposed surfaces of dirt and mud until the paving has been installed over the Structural Soil material. Do not wash until finished materials covering Structural Soil material are in place.



# REVISED DRAFT

This Document is a draft pending final approval. Please contact a CCDC Planner @ (619) 235-2200 to discuss your project.

This page intentionally left blank

# REVISED DRAFT

This Document is a draft pending final approval. Please contact a  
CCDC Planner @ (619) 235-2200 to discuss your project.

This page intentionally left blank

## ***IX. STREET TREE APPENDIX***

UPDATED: January 1, 2011

The following images of street trees are for reference only.

COLOR STREET TREE APPENDIX



*Cupaniopsis anacardioides* –  
Carrotwood



*Cupressus sempervirens* – Italian  
Cypress



*Fraxinus oxycarpa*- Raywood Ash



*Fraxinus uhdei* – Evergreen Ash





*Jacaranda mimosifolia* - **Jacaranda**



*Koelreuteria bipinnata* – **Chinese Flame Tree**



*Magnolia grandiflora* – **Southern Magnolia**



*Phoenix canariensis* – **Canary Island Date Palm**





*Pistacia chinensis* – Chinese Pistache



*Platanus acerifolia* – London Plane Tree



*Podocarpus gracilior* – Fern Pine



*Pyrus calleryana* 'Bradford' – Bradford Pear





*Pyrus calleryana* 'Chanticleer'-  
Chanticleer Pear



*Sapium sebiferum* – Chinese Tallow  
Tree



*Syagrus romanzoffianum* – Queen Palm



*Tipuana tipu* – Tipu Tree





*Tristania conferta* – Brisbane Box



*Ulmus parvifolia* – Chinese Evergreen Elm



*Washingtonia robusta* – Mexican Fan Palm

This page intentionally left blank