

City of San Diego

CONTRACTOR'S NAME: De La Fuente Construction, Inc.
ADDRESS: 121 E. 31st St., Suite C, National City, CA 91950
TELEPHONE NO.: 619-512-5505 **FAX NO.:** 619-878-2980
CITY CONTACT: Brittany Friedenreich, Contract Specialist, Email: BFriedenreic@san Diego.gov
Phone No. (619) 533-3104
M. Gonzalez / R. Bustamante / LJI

BIDDING DOCUMENTS



FOR

POINT LOMA OCEAN OUTFALL REPAIR

BID NO.: L-18-1710-DBB-1
SAP NO. (WBS/IO/CC): 21004004
CLIENT DEPARTMENT: 2012
COUNCIL DISTRICT: 2
PROJECT TYPE: BO

THIS CONTRACT WILL BE SUBJECT TO THE FOLLOWING:

- THE CITY'S SUBCONTRACTING PARTICIPATION REQUIREMENTS FOR SLBE PROGRAM.
- COMPETITION RESTRICTED TO: SLBE-ELBE or ELBE FIRMS ONLY .
- PREVAILING WAGE RATES: STATE FEDERAL
- APPRENTICESHIP

BID DUE DATE:

**1:30 PM
MARCH 22, 2018
CITY OF SAN DIEGO
PUBLIC WORKS CONTRACTS
525 B STREET, SUITE 750, MS 908A
SAN DIEGO, CA 92101**

DEPUTY CITY ENGINEER

The engineering Specifications and Special Provisions contained herein have been prepared by or under the direction of the following Registered Engineer:



Registered Engineer
For City Engineer

2/9/18

Date

Seal:



TABLE OF CONTENTS

| SECTION | PAGE |
|---|-------------|
| 1. NOTICE INVITING BIDS | 4 |
| 2. INSTRUCTIONS TO BIDDERS | 7 |
| 3. PERFORMANCE AND PAYMENT BONDS | 17 |
| 4. ATTACHMENTS: | |
| A. SCOPE OF WORK | 20 |
| B. INTENTIONALLY LEFT BLANK | 22 |
| C. INTENTIONALLY LEFT BLANK | 23 |
| D. PREVAILING WAGES | 24 |
| E. SUPPLEMENTARY SPECIAL PROVISIONS | 29 |
| 1. Appendix A - Notice of Exemption | 45 |
| 2. Appendix B - Intentionally Left Blank | 48 |
| 3. Appendix C - Materials Typically Accepted by Certificate of Compliance | 49 |
| 4. Appendix D - Sample City Invoice with Spend Curve | 51 |
| 5. Appendix E - Location Map | 54 |
| 6. Appendix F - As-Built and References | 56 |
| F. INTENTIONALLY LEFT BLANK | 60 |
| G. CONTRACT AGREEMENT | 61 |
| 5. CERTIFICATIONS AND FORMS | 64 |

NOTICE INVITING BIDS

1. **SUMMARY OF WORK:** This is the City of San Diego's (City) solicitation process to acquire Construction services for **POINT LOMA OCEAN OUTFALL REPAIR**. For additional information refer to Attachment A.
2. **LIMITED COMPETITION:** This contract may only be bid by the Contractors on the City's approved Prequalified Contractor's List **and** SLBE-ELBE Construction Limited Competition Contractors List in accordance with the designation stated on the cover page. For information regarding the SLBE-ELBE Construction Program and registration visit the City's web site: <http://www.sandiego.gov>.
3. **ESTIMATED CONSTRUCTION COST:** The City's estimated construction cost for this project is **\$230,000**.
4. **BID DUE DATE AND TIME ARE: March 22, 2018 at 1:30 PM.**
5. **PREVAILING WAGE RATES APPLY TO THIS CONTRACT:** Refer to Attachment D.
6. **LICENSE REQUIREMENT:** The City has determined that the following licensing classification is required for this contract: **A**
7. **ADDITIONAL CERTIFICATION REQUIREMENTS:** And Association of Diving Contractors (ADC) Certified.
8. **SUBCONTRACTING PARTICIPATION PERCENTAGES:** Subcontracting participation percentages apply to this contract.
 - 8.1. The City has incorporated **voluntary** subcontractor participation percentage to enhance competition and maximize subcontracting opportunities as follows.
 - 8.2. The following voluntary subcontractor participation percentage for DBE, DVBE, WBE, MBE, SLBE, and ELBE certified Subcontractors shall apply to this contract:

Total voluntary subcontractor participation percentage for this project is 5%.

9. **PRE-BID SITE VISIT:** All those wishing to submit a bid are **encouraged** to visit the Work Site with the Engineer. The purpose of the Site visit is to acquaint Bidders with the Site conditions. To request a sign language or oral interpreter for this visit, call the Public Works Contracts at (619) 533-3450 at least 5 Working Days prior to the meeting to ensure availability. The Pre-Bid Site Visit is scheduled as follows:

Time: 10:00 AM
Date: March 1, 2018
Location: Point Loma Wastewater Treatment Plant
1902 Gatchell Road
San Diego, CA 92106

10. **AWARD PROCESS:**

- 10.1. The Award of this contract is contingent upon the Contractor's compliance with all conditions of Award as stated within these documents and within the Notice of Intent to Award.
- 10.2. Upon acceptance of bids and determination of the apparent low bidder, the City will prepare the contract documents for execution within approximately 21 days of the date of the bid opening. The City will then award the contract upon receipt of properly signed Contract, bonds, and insurance documents.
- 10.3. This contract will be deemed executed and effective only upon the signing of the Contract by the Mayor or his designee and approval as to form by the City Attorney's Office.
- 10.4. The low Bid will be determined by Base Bid alone.
- 10.5. Once the low bid has been determined, the City may, at its sole discretion, award the contract for the Base bid alone.

11. **SUBMISSION OF QUESTIONS:**

- 11.1. The Director (or Designee) of the Public Works Department is responsible for opening, examining, and evaluating the competitive Bids submitted to the City for the acquisition, construction and completion of any public improvement except when otherwise set forth in these documents. Any questions related to this solicitation shall be submitted to:

Public Works Contracts
525 B Street, Suite 750, MS 908A
San Diego, California, 92101
Attention: Brittany Friedenreich

OR:

BFriedenreic@sandiego.gov

- 11.2.** Questions received less than 14 days prior to the date for opening of Bids may not be considered.
- 11.3.** Questions or clarifications deemed by the City to be material shall be answered via issuance of an addendum and posted to the City's online bidding service.
- 11.4.** Only questions answered by formal written addenda shall be binding. Oral and other interpretations or clarifications shall be without legal effect. It is the Bidder's responsibility to be informed of any addenda that have been issued and to include all such information in its Bid.

INSTRUCTIONS TO BIDDERS

1. PREQUALIFICATION OF CONTRACTORS:

- 1.1. Contractors submitting a Bid must be pre-qualified for the total amount proposed, including all alternate items, prior to the date of submittal. Bids from contractors who have not been pre-qualified as applicable and Bids that exceed the maximum dollar amount at which contractors are pre-qualified may be deemed **non-responsive** and ineligible for award. Complete information and links to the on-line prequalification application are available at:

<http://www.sandiego.gov/cip/bidopps/prequalification.shtml>

- 1.2. The completed application must be submitted online no later than 2 weeks prior to the bid opening.
- 1.3. Due to the City's responsibility to protect the confidentiality of the contractors' information, City staff will not be able to provide information regarding contractors' prequalification status over the telephone. Contractors may access real-time information about their prequalification status via their vendor profile on [PlanetBids™](#).

2. ELECTRONIC FORMAT RECEIPT AND OPENING OF BIDS: Bids will be received in electronic format (eBids) EXCLUSIVELY at the City of San Diego's electronic bidding (eBidding) site, at: <http://www.sandiego.gov/cip/bidopps/index.shtml> and are due by the date, and time shown on the cover of this solicitation.

- 2.1. **BIDDERS MUST BE PRE-REGISTERED** with the City's bidding system and possess a system-assigned Digital ID in order to submit and electronic bid.
- 2.2. The City's bidding system will automatically track information submitted to the site including IP addresses, browsers being used and the URLs from which information was submitted. In addition, the City's bidding system will keep a history of every login instance including the time of login, and other information about the user's computer configuration such as the operating system, browser type, version, and more. Because of these security features, Contractors who disable their browsers' cookies will not be able to log in and use the City's bidding system.
- 2.3. The City's electronic bidding system is responsible for bid tabulations. Upon the bidder's or proposer's entry of their bid, the system will ensure that all required fields are entered. **The system will not accept a bid for which any required information is missing.** This includes all necessary pricing, subcontractor listing(s) and any other essential documentation and supporting materials and forms requested or contained in these solicitation documents.

- 2.4. BIDS REMAIN SEALED UNTIL BID DEADLINE.** eBids are transmitted into the City's bidding system via hypertext transfer protocol secure (https) mechanism using SSL 128-256 bit security certificates issued from Verisign/Thawte which encrypts data being transferred from client to server. Bids submitted prior to the "Bid Due Date and Time" are not available for review by anyone other than the submitter which has until the "Bid Due Date and Time" to change, rescind or retrieve its proposal should it desire to do so.
- 2.5. BIDS MUST BE SUBMITTED BY BID DUE DATE AND TIME.** Once the bid deadline is reached, no further submissions are accepted into the system. Once the Bid Due Date and Time has lapsed, bidders, proposers, the general public, and City staff are able to immediately see the results on line. City staff may then begin reviewing the submissions for responsiveness, EOCB compliance and other issues. The City may require any Bidder to furnish statement of experience, financial responsibility, technical ability, equipment, and references.
- 2.6. RECAPITULATION OF THE WORK.** Bids shall not contain any recapitulation of the Work. Conditional Bids may be rejected as being non-responsive. Alternative proposals will not be considered unless called for.
- 2.7. BIDS MAY BE WITHDRAWN** by the Bidder only up to the bid due date and time.
- 2.7.1. Important Note:** Submission of the electronic bid into the system may not be instantaneous. Due to the speed and capabilities of the user's internet service provider (ISP), bandwidth, computer hardware and other variables, it may take time for the bidder's submission to upload and be received by the City's eBidding system. It is the bidder's sole responsibility to ensure their bids are received on time by the City's eBidding system. The City of San Diego is not responsible for bids that do not arrive by the required date and time.
- 2.8. ACCESSIBILITY AND AMERICANS WITH DISABILITIES ACT (ADA) COMPLIANCE:** To request a copy of this solicitation in an alternative format, contact the Public Works Contract Specialist listed on the cover of this solicitation at least five (5) working days prior to the Bid/Proposal due date to ensure availability.

3. ELECTRONIC BID SUBMISSIONS CARRY FULL FORCE AND EFFECT

- 3.1.** The bidder, by submitting its electronic bid, acknowledges that doing so carries the same force and full legal effect as a paper submission with a longhand (wet) signature.
- 3.2.** By submitting an electronic bid, the bidder certifies that the bidder has thoroughly examined and understands the entire Contract Documents (which consist of the plans and specifications, drawings, forms, affidavits and the solicitation documents), and that by submitting the eBid as its bid proposal, the bidder acknowledges, agrees to and is bound by the entire Contract Documents, including any addenda issued thereto, and incorporated by reference in the Contract Documents.

- 3.3.** The Bidder, by submitting its electronic bid, agrees to and certifies under penalty of perjury under the laws of the State of California, that the certification, forms and affidavits submitted as part of this bid are true and correct.
- 3.4.** The Bidder agrees to the construction of the project as described in Attachment “A – Scope of Work” for the City of San Diego, in accordance with the requirements set forth herein for the electronically submitted prices. The Bidder guarantees the Contract Price for a period of 120 days (90 days for federally funded contracts and contracts valued at \$500,000 or less) from the date of Bid opening. The duration of the Contract Price guarantee shall be extended by the number of days required for the City to obtain all items necessary to fulfill all conditions precedent.
- 4. BIDS ARE PUBLIC RECORDS:** Upon receipt by the City, Bids shall become public records subject to public disclosure. It is the responsibility of the respondent to clearly identify any confidential, proprietary, trade secret or otherwise legally privileged information contained within the Bid. General references to sections of the California Public Records Act (PRA) will not suffice. If the Contractor does not provide applicable case law that clearly establishes that the requested information is exempt from the disclosure requirements of the PRA, the City shall be free to release the information when required in accordance with the PRA, pursuant to any other applicable law, or by order of any court or government agency, and the Contractor will hold the City harmless for release of this information.
- 5. CONTRACTOR REGISTRATION AND ELECTRONIC REPORTING SYSTEM:**
- 5.1.** **Prior** to the Award of the Contract or Task Order, you and your Subcontractors and Suppliers must register with the City’s web-based vendor registration and bid management system. For additional information go to:

<http://www.sandiego.gov/purchasing/bids-contracts/vendorreg.shtml>.
- 5.2.** The City may not award the contract until registration of all subcontractors and suppliers is complete. In the event this requirement is not met within the time frame specified in the Notice of Intent to Award letter, the City reserves the right to rescind the Notice of Award / Intent to Award and to make the award to the next responsive and responsible bidder / proposer.
- 6. JOINT VENTURE CONTRACTORS:** Provide a copy of the Joint Venture agreement and the Joint Venture license to the City within 10 Working Days after receiving the Contract forms. See 7-6, “The Contractors Representative” in The GREENBOOK and 7-6.1 in The WHITEBOOK.
- 7. PREVAILING WAGE RATES WILL APPLY:** Refer to Attachment D.
- 8. SUBCONTRACTING PARTICIPATION PERCENTAGES:** Subcontracting participation percentages apply to this contract. Refer to Attachment E.

9. INSURANCE REQUIREMENTS:

- 9.1. All certificates of insurance and endorsements required by the contract are to be provided upon issuance of the City's Notice of Intent to Award letter.
- 9.2. Refer to sections 7-3, "LIABILITY INSURANCE", and 7-4, "WORKERS' COMPENSATION INSURANCE" of the Supplementary Special Provisions (SSP) for the insurance requirements which must be met.

10. REFERENCE STANDARDS: Except as otherwise noted or specified, the Work shall be completed in accordance with the following standards:

| Title | Edition | Document Number |
|---|---------|-----------------|
| Standard Specifications for Public Works Construction ("The GREENBOOK") http://www.greenbookspecs.org/ | 2015 | PWPI070116-01 |
| City of San Diego Standard Specifications for Public Works Construction ("The WHITEBOOK")* https://www.sandiego.gov/publicworks/edocref/greenbook | 2015 | PWPI070116-02 |
| City of San Diego Standard Drawings* https://www.sandiego.gov/publicworks/edocref/standarddraw | 2016 | PWPI070116-03 |
| Citywide Computer Aided Design and Drafting (CADD) Standards https://www.sandiego.gov/publicworks/edocref/drawings | 2016 | PWPI092816-04 |
| California Department of Transportation (CALTRANS) Standard Specifications – http://www.dot.ca.gov/des/oe/construction-contract-standards.html | 2015 | PWPI092816-05 |
| CALTRANS Standard Plans http://www.dot.ca.gov/des/oe/construction-contract-standards.html | 2015 | PWPI092816-06 |
| California Manual on Uniform Traffic Control Devices Revision 1 (CA MUTCD Rev 1) - http://www.dot.ca.gov/trafficops/camutcd/ | 2014 | PWPI092816-07 |
| NOTE: *Available online under Engineering Documents and References at: http://www.sandiego.gov/publicworks/edocref/index.shtml | | |

11. CITY'S RESPONSES AND ADDENDA: The City, at its discretion, may respond to any or all questions submitted in writing via the City's eBidding web site in the **form of an addendum**. No other responses to questions, oral or written shall be of any force or effect with respect to this solicitation. The changes to the Contract Documents through addenda are made effective as though originally issued with the Bid. The Bidders shall acknowledge the receipt of Addenda at the time of bid submission.

- 12. CITY'S RIGHTS RESERVED:** The City reserves the right to cancel the Notice Inviting Bids at any time, and further reserves the right to reject submitted Bids, without giving any reason for such action, at its sole discretion and without liability. Costs incurred by the Bidder(s) as a result of preparing Bids under the Notice Inviting Bids shall be the sole responsibility of each bidder. The Notice Inviting Bids creates or imposes no obligation upon the City to enter a contract.
- 13. CONTRACT PRICING:** This solicitation is for a Lump Sum contract with Unit Price provisions as set forth herein. The Bidder agrees to perform construction services for the City of San Diego in accordance with these contract documents for the prices listed below. The Bidder further agrees to guarantee the Contract Price for a period of 120 days from the date of Bid opening. The duration of the Contract Price guarantee may be extended, by mutual consent of the parties, by the number of days required for the City to obtain all items necessary to fulfill all contractual conditions.
- 14. SUBCONTRACTOR INFORMATION:**
- 14.1. LISTING OF SUBCONTRACTORS.** In accordance with the requirements provided in the "Subletting and Subcontracting Fair Practices Act" of the California Public Contract Code, the Bidder shall provide the **NAME** and **ADDRESS** of each Subcontractor who will perform work, labor, render services or who specially fabricates and installs a portion [type] of the work or improvement, in an amount in excess of 0.5% of the Contractor's total Bid. The Bidder shall also state within the description, whether the subcontractor is a **CONSTRUCTOR, CONSULTANT** or **SUPPLIER**. The Bidder shall state the **DIR REGISTRATION NUMBER** for all subcontractors and shall further state within the description, the **PORTION** of the work which will be performed by each subcontractor under this Contract. The Contractor shall list only one Subcontractor for each portion of the Work. The **DOLLAR VALUE** of the total Bid to be performed shall be stated for all subcontractors listed. Failure to comply with this requirement may result in the Bid being rejected as **non-responsive** and ineligible for award. The Bidder's attention is directed to the Special Provisions - General; Paragraph 2-3, "Subcontracts", which stipulates the percent of the Work to be performed with the Bidders' own forces. The Bidder shall list all SLBE, ELBE, DBE, DVBE, MBE, WBE, OBE, SDB, WoSB, HUBZone, and SDVOSB Subcontractors for which Bidders are seeking recognition towards achieving any mandatory, voluntary (or both) subcontracting participation goals.
- 14.2. LISTING OF SUPPLIERS.** Any Bidder seeking the recognition of Suppliers of equipment, materials, or supplies obtained from third party Suppliers towards achieving any mandatory or voluntary (or both) subcontracting participation goals shall provide, at a minimum, the **NAME, LOCATION (CITY), DIR REGISTRATION NUMBER** and the **DOLLAR VALUE** of each supplier. The Bidder will be credited up to 60% of the amount to be paid to the Suppliers for materials and supplies unless vendor manufactures or substantially alters materials and supplies, in which case, 100% will be credited. The Bidder is to indicate within the description whether the listed firm is a supplier or manufacturer. If no indication is provided, the listed firm will be credited at 60% of the listed dollar value for purposes of calculating the Subcontractor Participation Percentage.

- 14.3. LISTING OF SUBCONTRACTORS OR SUPPLIERS FOR ALTERNATES.** For subcontractors or suppliers to be used on additive or deductive alternate items, in addition to the above requirements, bidder shall further note "ALTERNATE" and alternate item number within the description.
- 15. SUBMITTAL OF "OR EQUAL" ITEMS:** See Section 4-1.6, "Trade Names or Equals" in The WHITEBOOK and as amended in the SSP.
- 16. AWARD:**
- 16.1.** The Award of this contract is contingent upon the Contractor's compliance with all conditions precedent to Award.
- 16.2.** Upon acceptance of a Bid, the City will prepare contract documents for execution within approximately 21 days of the date of the Bid opening and award the Contract approximately within 7 days of receipt of properly executed Contract, bonds, and insurance documents.
- 16.3.** This contract will be deemed executed and effective only upon the signing of the Contract by the Mayor or his designee and approval as to form the City Attorney's Office.
- 17. SUBCONTRACT LIMITATIONS:** The Bidder's attention is directed to Standard Specifications for Public Works Construction, Section 2-3, "SUBCONTRACTS" in The GREENBOOK and as amended in the SSP which requires the Contractor to self-perform not less than the specified amount. Failure to comply with this requirement shall render the bid **non-responsive** and ineligible for award.
- 18. AVAILABILITY OF PLANS AND SPECIFICATIONS:** Contract Documents may be obtained by visiting the City's website: <http://www.sandiego.gov/cip/>. Plans and Specifications for this contract are also available for review in the office of the City Clerk or Public Works Contracts.
- 19. ONLY ONE BID PER CONTRACTOR SHALL BE ACCEPTED:** No person, firm, or corporation shall be allowed to make, file, or be interested in more than one (1) Bid for the same work unless alternate Bids are called for. A person, firm or corporation who has submitted a sub-proposal to a Bidder, or who has quoted prices on materials to a Bidder, is not hereby disqualified from submitting a sub-proposal or quoting prices to other Bidders or from submitting a Bid in its own behalf. Any Bidder who submits more than one bid will result in the rejection of all bids submitted.
- 20. SAN DIEGO BUSINESS TAX CERTIFICATE:** The Contractor and Subcontractors, not already having a City of San Diego Business Tax Certificate for the work contemplated shall secure the appropriate certificate from the City Treasurer, Civic Center Plaza, First floor and submit to the Contract Specialist upon request or as specified in the Contract Documents. Tax Identification numbers for both the Bidder and the listed Subcontractors must be submitted on the City provided forms within these documents.

21. BIDDER'S GUARANTEE OF GOOD FAITH (BID SECURITY) FOR DESIGN-BID-BUILD CONTRACTS:

- 21.1.** For bids \$250,000 and above, bidders shall submit Bid Security at bid time. Bid Security shall be in one of the following forms: a cashier's check, or a properly certified check upon some responsible bank; or an approved corporate surety bond payable to the City of San Diego for an amount of not less than 10% of the total bid amount.
- 21.2.** This check or bond, and the monies represented thereby, will be held by the City as a guarantee that the Bidder, if awarded the contract, will in good faith enter into the contract and furnish the required final performance and payment bonds.
- 21.3.** The Bidder agrees that in the event of the Bidder's failure to execute this contract and provide the required final bonds, the money represented by the cashier's or certified check will remain the property of the City; and the Surety agrees that it will pay to the City the damages, not exceeding the sum of 10% of the amount of the Bid, that the City may suffer as a result of such failure.
- 21.4.** At the time of bid submission, bidders must upload and submit an electronic PDF copy of the aforementioned bid security. Whether in the form of a cashier's check, a properly certified check or an approved corporate surety bond payable to the City of San Diego, the bid security must be uploaded to the City's eBidding system. Within twenty-four (24) hours after the bid due date and time, the first five (5) apparent low bidders must provide the City with the original bid security.
- 21.5.** Failure to submit the electronic version of the bid security at the time of bid submission AND failure to provide the original within twenty-four (24) hours may cause the bid to be rejected and deemed **non-responsive**.

22. AWARD OF CONTRACT OR REJECTION OF BIDS:

- 22.1.** This contract may be awarded to the lowest responsible and reliable Bidder.
- 22.2.** Bidders shall complete ALL eBid forms as required by this solicitation. Incomplete eBids will not be accepted.
- 22.3.** The City reserves the right to reject any or all Bids, to waive any informality or technicality in Bids received, and to waive any requirements of these specifications as to bidding procedure.
- 22.4.** Bidders will not be released on account of their errors of judgment. Bidders may be released only upon receipt by the City within 3 Working Days of the bid opening, written notice from the Bidder which shows proof of honest, credible, clerical error of a material nature, free from fraud or fraudulent intent; and of evidence that reasonable care was observed in the preparation of the Bid.

- 22.5. A bidder who is not selected for contract award may protest the award of a contract to another bidder by submitting a written protest in accordance with the San Diego Municipal Code.
- 22.6. The City of San Diego will not discriminate in the award of contracts with regard to race, religion, creed, color, national origin, ancestry, physical handicap, marital status, sex or age.
- 22.7. Each Bid package properly signed as required by these specifications shall constitute a firm offer which may be accepted by the City within the time specified herein.
- 22.8. The City reserves the right to evaluate all Bids and determine the lowest Bidder on the basis of the base bid and any proposed alternates or options as detailed herein.

23. BID RESULTS:

- 23.1. The availability of the bids on the City's eBidding system shall constitute the public announcement of the apparent low bidder. In the event that the apparent low bidder is subsequently deemed non-responsive or non-responsible, a notation of such will be made on the eBidding system. The new ranking and apparent low bidder will be adjusted accordingly.
- 23.2. To obtain the bid results, view the results on the City's web site, or request the results by U.S. mail and provide a self-addressed, stamped envelope. If requesting by mail, be sure to reference the bid name and number. The bid tabulations will be mailed to you upon their completion. The results will not be given over the telephone.

24. THE CONTRACT:

- 24.1. The Bidder to whom award is made shall execute a written contract with the City of San Diego and furnish good and approved bonds and insurance certificates specified by the City within 14 days after receipt by Bidder of a form of contract for execution unless an extension of time is granted to the Bidder in writing.
- 24.2. If the Bidder takes longer than 14 days to fulfill these requirements, then the additional time taken shall be added to the Bid guarantee. The Contract shall be made in the form adopted by the City, which includes the provision that no claim or suit whatsoever shall be made or brought by Contractor against any officer, agent, or employee of the City for or on account of anything done or omitted to be done in connection with this contract, nor shall any such officer, agent, or employee be liable hereunder.
- 24.3. If the Bidder to whom the award is made fails to enter into the contract as herein provided, the award may be annulled and the Bidder's Guarantee of Good Faith will be subject to forfeiture. An award may be made to the next lowest responsible and reliable Bidder who shall fulfill every stipulation embraced herein as if it were the party to whom the first award was made.

- 24.4.** Pursuant to the San Diego City Charter section 94, the City may only award a public works contract to the lowest responsible and reliable Bidder. The City will require the Apparent Low Bidder to (i) submit information to determine the Bidder's responsibility and reliability, (ii) execute the Contract in form provided by the City, and (iii) furnish good and approved bonds and insurance certificates specified by the City within 14 Days, unless otherwise approved by the City, in writing after the Bidder receives notification from the City, designating the Bidder as the Apparent Low Bidder and formally requesting the above mentioned items.
- 24.5.** The award of the Contract is contingent upon the satisfactory completion of the above-mentioned items and becomes effective upon the signing of the Contract by the Mayor or designee and approval as to form the City Attorney's Office. If the Apparent Low Bidder does not execute the Contract or submit required documents and information, the City may award the Contract to the next lowest responsible and reliable Bidder who shall fulfill every condition precedent to award. A corporation designated as the Apparent Low Bidder shall furnish evidence of its corporate existence and evidence that the officer signing the Contract and bond for the corporation is duly authorized to do so.
- 25. EXAMINATION OF PLANS, SPECIFICATIONS, AND SITE OF WORK:** The Bidder shall examine carefully the Project Site, the Plans and Specifications, other materials as described in the Special Provisions, Section 2-7, and the proposal forms (e.g., Bidding Documents). The submission of a Bid shall be conclusive evidence that the Bidder has investigated and is satisfied as to the conditions to be encountered, as to the character, quality, and scope of Work, the quantities of materials to be furnished, and as to the requirements of the Bidding Documents Proposal, Plans, and Specifications.
- 26. CITY STANDARD PROVISIONS:** This contract is subject to the following standard provisions. See The WHITEBOOK for details.
- 26.1.** The City of San Diego Resolution No. R-277952 adopted on May 20, 1991 for a Drug-Free Workplace.
- 26.2.** The City of San Diego Resolution No. R-282153 adopted on June 14, 1993 related to the Americans with Disabilities Act.
- 26.3.** The City of San Diego Municipal Code §22.3004 for Contractor Standards.
- 26.4.** The City of San Diego's Labor Compliance Program and the State of California Labor Code §§1771.5(b) and 1776.
- 26.5.** Sections 1777.5, 1777.6, and 1777.7 of the State of California Labor Code concerning the employment of apprentices by contractors and subcontractors performing public works contracts.
- 26.6.** The City's Equal Benefits Ordinance (EBO), Chapter 2, Article 2, Division 43 of The San Diego Municipal Code (SDMC).
- 26.7.** The City's Information Security Policy (ISP) as defined in the City's Administrative Regulation 90.63.

27. PRE-AWARD ACTIVITIES:

- 27.1.** The contractor selected by the City to execute a contract for this Work shall submit the required documentation as specified in the herein and in the Notice of Award. Failure to provide the information as specified may result in the Bid being rejected as **non-responsive**.
- 27.2.** The decision that bid is non-responsive for failure to provide the information required within the time specified shall be at the sole discretion of the City.

FAITHFUL PERFORMANCE BOND AND LABOR AND MATERIALMEN'S BOND:

De La Fuente Construction, Inc. _____, a corporation, as principal, and
The Gray Insurance Company _____, a corporation authorized to do
business in the State of California, as Surety, hereby obligate themselves, their successors
and assigns, jointly and severally, to The City of San Diego a municipal corporation in the
sum of **One Hundred Eighty Six Thousand Seven Hundred Seventy Seven Dollars and Zero
Cents, (\$186,777.00)**, for the faithful performance of the annexed contract, and in the sum
of **One Hundred Eighty Six Thousand Seven Hundred Seventy Seven Dollars and Zero
Cents, (\$186,777.00)**, for the benefit of laborers and materialmen designated below.

Conditions:

If the Principal shall faithfully perform the annexed contract with the City of San Diego,
California, then the obligation herein with respect to a faithful performance shall be void; otherwise
it shall remain in full force.

If the Principal shall promptly pay all persons, firms and corporations furnishing materials
for or performing labor in the execution of this contract, and shall pay all amounts due under the
California Unemployment Insurance Act then the obligation herein with respect to laborers and
materialmen shall be void; otherwise it shall remain in full force.

The obligation herein with respect to laborers and materialmen shall inure to the benefit of
all persons, firms and corporations entitled to file claims under the provisions of Article 2. Claimants,
(iii) public works of improvement commencing with Civil Code Section 9100 of the Civil Code of the
State of California.

Changes in the terms of the annexed contract or specifications accompanying same or
referred to therein shall not affect the Surety's obligation on this bond, and the Surety hereby
waives notice of same.

PERFORMANCE BOND, LABOR AND MATERIALMEN'S BOND (continued)

The Surety shall pay reasonable attorney's fees should suit be brought to enforce the provisions of this bond.

Dated March 28, 2018

Approved as to Form

De La Fuente Construction, Inc.

Principal

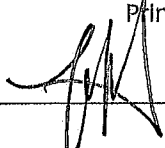
By 

Jorge Diaz

Printed Name of Person Signing for Principal

Mara W. Elliott, City Attorney

By 

Deputy City Attorney

The Gray Insurance Company

Surety

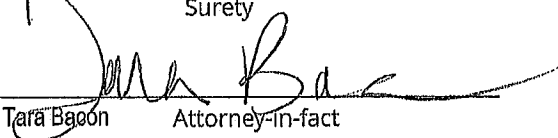
By 

Tara Bacon Attorney-in-fact

Approved:

10040 N. 25th Ave., Suite 118

Local Address of Surety

By Brittany Friedenreich

Brittany Friedenreich
Contract Specialist
Public Works Department

Phoenix, AZ 85021

Local Address (City, State) of Surety

(602) 354-3117

Local Telephone No. of Surety

Premium \$ 3,736.00

Bond No. GSM35335

CALIFORNIA ALL-PURPOSE ACKNOWLEDGMENT

CIVIL CODE § 1189

A notary public or other officer completing this certificate verifies only the identity of the individual who signed the document to which this certificate is attached, and not the truthfulness, accuracy, or validity of that document.

State of California
County of San Diego)

On March 28, 2018 before me, Diana Kai Murphy, Notary Public
(insert name and title of the officer)

personally appeared Tara Bacon,
who proved to me on the basis of satisfactory evidence to be the person(s) whose name(s) is/are subscribed to the within instrument and acknowledged to me that he/she/they executed the same in his/her/their authorized capacity(ies), and that by his/her/their signature(s) on the instrument the person(s), or the entity upon behalf of which the person(s) acted, executed the instrument.

I certify under PENALTY OF PERJURY under the laws of the State of California that the foregoing paragraph is true and correct.

WITNESS my hand and official seal.

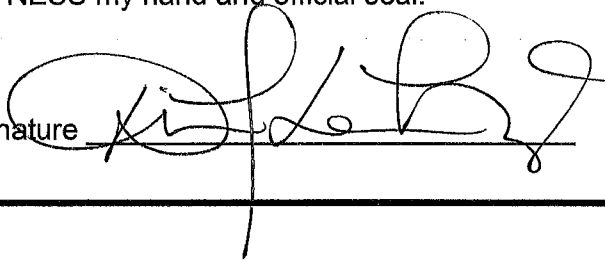
Signature  (Seal)



THE GRAY CASUALTY & SURETY COMPANY

THE GRAY INSURANCE COMPANY

214360

GENERAL POWER OF ATTORNEY

KNOW ALL BY THESE PRESENTS, THAT The Gray Insurance Company and The Gray Casualty & Surety Company, corporations duly organized and existing under the laws of Louisiana, and having their principal offices in Metairie, Louisiana, do hereby make, constitute, and appoint Tara Bacon, Minna Huoivila, Kyle King and John R. Qualin of San Diego, California jointly and severally on behalf of each of the Companies named above its true and lawful Attorney(s)-in-Fact, to make, execute, seal and deliver, for and on its behalf and as its deed, bonds, or other writings obligatory in the nature of a bond, as surety, contracts of suretyship as are or may be required or permitted by law, regulation, contract or otherwise, provided that no bond or undertaking or contract of suretyship executed under this authority shall exceed the amount of \$10,000,000.00

This Power of Attorney is granted and is signed by facsimile under and by the authority of the following Resolutions adopted by the Boards of Directors of both The Gray Insurance Company and The Gray Casualty & Surety Company at meetings duly called and held on the 26th day of June, 2003.

"RESOLV ED, that the President, Executive Vice President, any Vice President, or the Secretary be and each or any of them hereby is authorized to execute a power of Attorney qualifying the attorney named in the given Power of Attorney to execute on behalf of the Company bonds, undertakings, and all contracts of surety, and that each or any of them is hereby authorized to attest to the execution of such Power of Attorney, and to attach the seal of the Company; and it is

FURTHER RESOLVED, that the signature of such officers and the seal of the Company may be affixed to any such Power of Attorney or to any certificate relating thereto by facsimile, and any such Power of Attorney or certificate bearing such facsimile signature or facsimile seal shall be binding upon the Company now and in the future when so affixed with regard to any bond, undertaking or contract of surety to which it is attached.

IN WITNESS WHEREOF, The Gray Insurance Company and The Gray Casualty & Surety Company have caused their official seals to be hereinto affixed, and these presents to be signed by their authorized officers this 12th day of September, 2011.



By:

Michael T. Gray

Michael T. Gray
President, The Gray Insurance Company
and
Vice President,
The Gray Casualty & Surety Company

Attest:

Mark S. Manguno

Mark S. Manguno
Secretary,
The Gray Insurance Company,
The Gray Casualty & Surety Company



State of Louisiana

ss:

Parish of Jefferson

On this 12th day of September, 2011, before me, a Notary Public, personally appeared Michael T. Gray, President of The Gray Insurance Company and Vice President of The Gray Casualty & Surety Company, and Mark S. Manguno, Secretary of The Gray Insurance Company and The Gray Casualty & Surety Company, personally known to me, being duly sworn, acknowledged that they signed the above Power of Attorney and affixed the seals of the companies as officers of, and acknowledged said instrument to be the voluntary act and deed, of their companies.

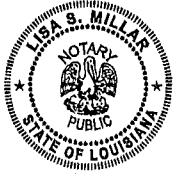

Lisa S. Millar

Lisa S. Millar, Notary Public, Parish of Orleans
State of Louisiana
My Commission is for Life

I, Mark S. Manguno, Secretary of The Gray Insurance Company and The Gray Casualty & Surety Company, do hereby certify that the above and forgoing is a true and correct copy of a Power of Attorney given by the companies, which is still in full force and effect.

IN WITNESS WHEREOF, I have set my hand and affixed the seals of the Companies this

28th day of March

2018



Mark S. Manguno

Mark S. Manguno, Secretary
The Gray Insurance Company
The Gray Casualty & Surety Company

ATTACHMENTS

ATTACHMENT A
SCOPE OF WORK

SCOPE OF WORK

- 1. SCOPE OF WORK:** Contract with an ocean diving company to install a Weko seal, repair grout and provide a damage assessment of a spalled section within the Point Loma Ocean Outfall. For further information, see Supplementary Special Provisions, Section 318.
 - 1.1.** The Work shall be performed in accordance with:
 - 1.1.1.** The Notice Inviting Bids, inclusive.
- 2. ESTIMATED CONSTRUCTION COST:** The City's estimated construction cost for this project is **\$230,000.**
- 3. LOCATION OF WORK: The location of the Work is as follows:**

1902 Gatchell Rd., San Diego, CA 92106
- 4. CONTRACT TIME:** The Contract Time for completion of the Work shall be **90 Working Days.**

ATTACHMENT B
INTENTIONALLY LEFT BLANK

ATTACHMENT C
INTENTIONALLY LEFT BLANK

ATTACHMENT D
PREVAILING WAGES

PREVAILING WAGES

1. **PREVAILING WAGE RATES:** Pursuant to San Diego Municipal Code section 22.3019, construction, alteration, demolition, repair and maintenance work performed under this Contract is subject to State prevailing wage laws. For construction work performed under this Contract cumulatively exceeding \$25,000 and for alteration, demolition, repair and maintenance work performed under this Contract cumulatively exceeding \$15,000, the Contractor and its subcontractors shall comply with State prevailing wage laws including, but not limited to, the requirements listed below.
 - 1.1. **Compliance with Prevailing Wage Requirements.** Pursuant to sections 1720 through 1861 of the California Labor Code, the Contractor and its subcontractors shall ensure that all workers who perform work under this Contract are paid not less than the prevailing rate of per diem wages as determined by the Director of the California Department of Industrial Relations (DIR). This includes work performed during the design and preconstruction phases of construction including, but not limited to, inspection and land surveying work.
 - 1.1.1. Copies of such prevailing rate of per diem wages are on file at the City and are available for inspection to any interested party on request. Copies of the prevailing rate of per diem wages also may be found at <http://www.dir.ca.gov/OPRL/DPreWageDetermination.htm>. Contractor and its subcontractors shall post a copy of the prevailing rate of per diem wages determination at each job site and shall make them available to any interested party upon request.
 - 1.1.2. The wage rates determined by the DIR refer to expiration dates. If the published wage rate does not refer to a predetermined wage rate to be paid after the expiration date, then the published rate of wage shall be in effect for the life of this Contract. If the published wage rate refers to a predetermined wage rate to become effective upon expiration of the published wage rate and the predetermined wage rate is on file with the DIR, such predetermined wage rate shall become effective on the date following the expiration date and shall apply to this Contract in the same manner as if it had been published in said publication. If the predetermined wage rate refers to one or more additional expiration dates with additional predetermined wage rates, which expiration dates occur during the life of this Contract, each successive predetermined wage rate shall apply to this Contract on the date following the expiration date of the previous wage rate. If the last of such predetermined wage rates expires during the life of this Contract, such wage rate shall apply to the balance of the Contract.
 - 1.2. **Penalties for Violations.** Contractor and its subcontractors shall comply with California Labor Code section 1775 in the event a worker is paid less than the prevailing wage rate for the work or craft in which the worker is employed. This shall be in addition to any other applicable penalties allowed under Labor Code sections 1720 – 1861.

1.3. Payroll Records. Contractor and its subcontractors shall comply with California Labor Code section 1776, which generally requires keeping accurate payroll records, verifying and certifying payroll records, and making them available for inspection. Contractor shall require its subcontractors to also comply with section 1776. Contractor and its subcontractors shall submit weekly certified payroll records online via the City's web-based Labor Compliance Program. Contractor is responsible for ensuring its subcontractors submit certified payroll records to the City.

1.3.1. Contractor and their subcontractors shall also furnish records specified in Labor Code section 1776 directly to the Labor Commissioner in the manner required by Labor Code section 1771.4.

1.4. Apprentices. Contractor and its subcontractors shall comply with California Labor Code sections 1777.5, 1777.6 and 1777.7 concerning the employment and wages of apprentices. Contractor is held responsible for the compliance of their subcontractors with sections 1777.5, 1777.6 and 1777.7.

1.5. Working Hours. Contractor and their subcontractors shall comply with California Labor Code sections 1810 through 1815, including but not limited to: (i) restrict working hours on public works contracts to eight hours a day and forty hours a week, unless all hours worked in excess of 8 hours per day are compensated at not less than 1½ times the basic rate of pay; and (ii) specify penalties to be imposed on contractors and subcontractors of \$25 per worker per day for each day the worker works more than 8 hours per day and 40 hours per week in violation of California Labor Code sections 1810 through 1815.

1.6. Required Provisions for Subcontracts. Contractor shall include at a minimum a copy of the following provisions in any contract they enter into with a subcontractor: California Labor Code sections 1771, 1771.1, 1775, 1776, 1777.5, 1810, 1813, 1815, 1860 and 1861.

1.7. Labor Code Section 1861 Certification. Contractor in accordance with California Labor Code section 3700 is required to secure the payment of compensation of its employees and by signing this Contract, Contractor certifies that "I am aware of the provisions of Section 3700 of the California Labor Code which require every employer to be insured against liability for workers' compensation or to undertake self-insurance in accordance with the provisions of that code, and I will comply with such provisions before commencing the performance of the work of this Contract."

1.8. Labor Compliance Program. The City has its own Labor Compliance Program authorized in August 2011 by the DIR. The City will withhold contract payments when payroll records are delinquent or deemed inadequate by the City or other governmental entity, or it has been established after an investigation by the City or other governmental entity that underpayment(s) have occurred. For questions or assistance, please contact the City of San Diego's Equal Opportunity Contracting Department at 619-236-6000.

- 1.9. Contractor and Subcontractor Registration Requirements.** This project is subject to compliance monitoring and enforcement by the DIR. A contractor or subcontractor shall not be qualified to bid on, be listed in a bid or proposal, subject to the requirements of section 4104 of the Public Contract Code, or engage in the performance of any contract for public work, unless currently registered and qualified to perform public work pursuant to Labor Code section 1725.5. It is not a violation of this section for an unregistered contractor to submit a bid that is authorized by Section 7029.1 of the Business and Professions code or by Section 10164 or 20103.5 of the Public Contract Code, provided the contractor is registered to perform public work pursuant to Section 1725.5 at the time the contract is awarded.
- 1.9.1.** A Contractor's inadvertent error in listing a subcontractor who is not registered pursuant to Labor Code section 1725.5 in response to a solicitation shall not be grounds for filing a bid protest or grounds for considering the bid non-responsive provided that any of the following apply: (1) the subcontractor is registered prior to bid opening; (2) within twenty-four hours after the bid opening, the subcontractor is registered and has paid the penalty registration fee specified in Labor Code section 1725.5; or (3) the subcontractor is replaced by another registered subcontractor pursuant to Public Contract Code section 4107.
- 1.9.2.** By submitting a bid or proposal to the City, Contractor is certifying that he or she has verified that all subcontractors used on this public work project are registered with the DIR in compliance with Labor Code sections 1771.1 and 1725.5, and Contractor shall provide proof of registration for themselves and all listed subcontractors to the City at the time of bid or proposal due date or upon request.
- 1.10. Stop Order.** For Contractor or its subcontractors engaging in the performance of any public work contract without having been registered in violation of Labor Code sections 1725.5 or 1771.1, the Labor Commissioner shall issue and serve a stop order prohibiting the use of the unregistered contractors or unregistered subcontractor(s) on ALL public works until the unregistered contractor or unregistered subcontractor(s) is registered. Failure to observe a stop order is a misdemeanor.
- 1.11. List of all Subcontractors.** The City may ask Contractor for the most current list of subcontractors (regardless of tier), along with their DIR registration numbers, utilized on this Agreement at any time during performance of this contract, and Contractor shall provide the list within ten (10) working days of the City's request. Additionally, Contractor shall provide the City with a complete list of all subcontractors utilized on this contract (regardless of tier), within ten working days of the completion of the contract, along with their DIR registration numbers. The City shall withhold final payment to Contractor until at least 30 days after this information is provided to the City.
- 1.12. Exemptions for Small Projects.** There are limited exemptions for installation, alteration, demolition, or repair work done on projects of \$25,000 or less. The Contractor shall still comply with Labor Code sections 1720 et. seq. The only recognized exemptions are listed below:

- 1.12.1.** Registration. The Contractor will not be required to register with the DIR for small projects. (Labor Code section 1771.1)
- 1.12.2.** Certified Payroll Records. The records required in Labor Code section 1776 shall be required to be kept and submitted to the City of San Diego, but will not be required to be submitted online with the DIR directly. The Contractor will need to keep those records for at least three years following the completion of the Contract. (Labor Code section 1771.4).
- 1.12.3.** List of all Subcontractors. The Contractor shall not be required to hire only registered subcontractors and is exempt from submitting the list of all subcontractors that is required in section 4.20.11 above. (Labor code section 1773.3).

ATTACHMENT E
SUPPLEMENTARY SPECIAL PROVISIONS

SUPPLEMENTARY SPECIAL PROVISIONS

The following Supplementary Special Provisions (SSP) modifies the following documents:

1. The **2015 Edition** of the Standard Specifications for Public Works Construction (The "GREENBOOK").
2. The **2015 Edition** of the City of San Diego Standard Specifications for Public Works Construction (The "WHITEBOOK"), including the following:
 - a) General Provisions (A) for all Contracts.

SECTION 1 – TERMS, DEFINITIONS, ABBREVIATIONS, UNITS OF MEASURE, AND SYMBOLS

- 1-2 TERMS AND DEFINITIONS.** To the "WHITEBOOK", item 54, "Normal Working Hours", ADD the following:

The **Normal Working Hours** are 5:00 PM to 5:00 AM. See **SECTION 7-23, AFTER HOURS ACCESS TO JOB SITE.**

SECTION 2 - SCOPE AND CONTROL OF WORK

- 2-3.2 Self Performance.** To the "GREENBOOK", DELETE in its entirety and SUBSTITUTE with the following:

1. You shall perform, with your own organization, Contract Work amounting to at least 50% of the base Bid **AND** 50% of any alternates.

ADD:

- 2-10 AUTHORITY OF THE BOARD AND THE ENGINEER.** To the "GREENBOOK", Paragraph (2), DELETE in its entirety and SUBSTITUTE with the following:

The decision of the Engineer is final and binding on all questions relating to: quantities; acceptability of material, equipment, or work; execution, progress or sequence of work; requests for information (RFI), and interpretation of the Plans, Specifications, or other Contract Documents. This shall be precedent to any payment under the Contract. The Engineer shall be the single point of contact and shall be included in all communications.

- 2-16 CONTRACTOR REGISTRATION AND ELECTRONIC REPORTING SYSTEM.** To the "WHITEBOOK", item 1, DELETE in its entirety.

SECTION 3 – CHANGES IN WORK

3-5.1 **Claims.** To the “WHITEBOOK”, DELETE in its entirety and SUBSTITUTE with the following:

**ADD:
3-5.1**

Claims.

1. A Claim is a written demand by you that seeks an adjustment in the Contract Price, Contract Time, or other relief associated with a dispute arising under or relating to the Contract, including a breach of any provision thereof. A voucher, invoice, or other routine request for payment is not a Claim.
2. A Claim shall conform to these specifications and may be considered after the City has previously denied a request by you for a Change Order seeking the demanded relief.
3. You shall submit a Claim to the Engineer if a dispute occurs that arises from or relates to the Contract. The Claim shall seek all relief to which you assert you are entitled as a result of the event(s) giving rise to the dispute. Your failure to process a Claim in accordance with these specifications shall constitute a waiver of all relief associated with the dispute. Claims are subject to 6-11, “Right to Audit”.
4. You shall continue to perform the Services and Work and shall maintain the Schedule during any dispute proceedings. The Engineer will continue to make payments for undisputed Services and Work.
5. The City’s Claims process specified herein shall not relieve you of your statutory obligations to present claims prior to any action under the California Government Code.

3-5.1.1 **Initiation of Claim.**

1. You shall promptly, but no later than 30 Days after the event(s) giving rise to the Claim, deliver the Claim to the Engineer.
2. You shall not process a Claim unless the Engineer has previously denied a request by you for a Change Order that sought the relief to be pursued in the claim.

3-5.1.1.1 **Claim Certification Submittal.**

1. If your Claim seeks an increase in the Contract Price, the Contract Time, or both, submit with the Claim an affidavit certifying the following:
 - a) The Claim is made in good faith and covers all costs and delays to which you are entitled as a result of the event(s) giving rise to the Claim.
 - b) The amount claimed accurately reflects the adjustments in the Contract Price, the Contract Time, or both to which you believe you are entitled.

- c) All supporting costs and pricing data are current, accurate, and complete to the best of your knowledge. The cost breakdown per item of Work shall be supplied.
- d) You shall ensure that the affidavit is executed by an official who has the authority to legally bind you.

3-5.1.2 Initial Determination.

- 1. The Engineer will respond in writing to your Claim within 30 Days of receipt of the Claim.

3-5.1.3 Settlement Meeting.

- 1. If you disagree with the Initial Determination, you shall request a Settlement Meeting within 30 Days. Upon receipt of this request, the Engineer will schedule the Settlement Meeting within 15 Working Days.

3-5.1.4 City's Final Determination.

- 1. If a settle agreement is not reached, the City shall make a written Final Determination within 10 Working Days after the Settlement Meeting.
- 2. If you disagree with the City's Final Determination, notify the Engineer in writing of your objection within 15 Working Days after receipt of the written determination and file a "Request for Mediation" in accordance with 3-5.2, "Dispute Resolution Process".
- 3. Failure to give notice of objection within the 15 Working Days period shall waive your right to pursue the Claim.

3-5.1.5 Mandatory Assistance.

- 1. If a third party dispute, litigation, or both arises out of or relates in any way to the Services provided under the Contract, upon the City's request, you shall agree to assist in resolving the dispute or litigation. Your assistance includes, but is not limited to the following:
 - a) Providing professional consultations.
 - b) Attending mediations, arbitrations, depositions, trials, or any event related to the dispute resolution and litigation.

3-5.1.5.1 Compensation for Mandatory Assistance.

- 1. The City will reimburse you for reasonable fees and expenses incurred by you for any required assistance rendered in accordance with 3-5.1.8, "Mandatory Assistance" as Extra Work.

2. The Engineer will determine whether these fees and expenses were necessary due to your conduct or failure to act.
3. If the Engineer determines that the basis of the dispute or litigation in which these fees and expenses were incurred were the result of your conduct or your failure to act in part or in whole, you shall reimburse the City for any payments made for these fees and expenses.
4. Reimbursement may be through any legal means necessary, including the City's withholding of your payment.

3-5.2.3 Selection of Mediator. To the "WHITEBOOK", DELETE in its entirety and SUBSTITUTE with the following:

1. A single mediator, knowledgeable in construction aspects and acceptable to both parties, shall be used to mediate the dispute.
2. To initiate mediation, the initiating party shall serve a Request for Mediation at the American Arbitration Association (AAA) on the opposing party.
3. If AAA is used, the initiating party shall concurrently file with AAA a "Request for Mediation" along with the appropriate fees, a copy of requested mediators marked in preference order, and a preference for available dates.
4. If AAA is selected to coordinate the mediation (Administrator), within 10 Working Days from the receipt of the initiating party's Request for Mediation, the opposing party shall file the following:
 - a) A copy of the list of the preferred mediators listed in preference order after striking any mediators to which they have any objection.
 - b) A preference for available dates.
 - c) Appropriate fees.
5. If the parties cannot agree on a mediator, then each party shall select a mediator and those mediators shall select the neutral third party to mediate the matter.

3-5.3 Forum of Litigation. To the "WHITEBOOK", DELETE in its entirety and SUBSTITUTE with the following:

1. It is the express intention that all legal actions and proceedings related to the Contract or Agreement with the City or to any rights or any relationship between the parties arising therefrom shall be solely and exclusively initiated and maintained in courts of the State of California for the County of San Diego.

SECTION 4 - CONTROL OF MATERIALS

4-1.1 General. To the "GREENBOOK", ADD the following:

1. The City of San Diego requires all vendors supplying chemicals to comply with the Globally Harmonized System (GHS) adopted for manufacturers and distributors. All bidders must have onsite 1 additional copy, for a total of 2 copies of the material safety data sheet (SDS) for each product onsite. Only those products whose SDS clearly state contents, hazard potential(s), and protective measures required shall be considered for bid. Contractor must also send with each equipment one (1) copy of SDS for each item shipped. Failure to comply with this procedure will cause for immediate termination of the contract for violation of safety procedures. An electronic version of the SDS for each chemical on this contract shall be furnished to the Contract Administrator, or designee, as required. Updates must be provided as soon as they become available. Failure to comply with this requirement may be grounds for termination of contract.
2. All work shall be performed in accordance with the best practices and shall be in keeping with the high aesthetic level of the facility being maintained. The contractor shall provide comprehensive ongoing inspection of the job site (s). The inspection shall be performed by the field supervisor as well as a non-working supervisor who shall report any findings to the City.

4-1.3.5 Special Inspection. To the "WHITEBOOK", ADD the following:

5. The payment for special inspection Work specified under this section shall be paid in accordance with 4-1.3.4.1, "Payment".

4-1.3.6 Preapproved Materials. To the "WHITEBOOK", ADD the following:

3. You shall submit in writing a list of all products to be incorporated in the Work that are on the AML.

4-1.6 Trade Names or Equals. To the "WHITEBOOK", ADD the following:

11. You shall submit your list of proposed substitutions for an "equal" item **no less than 15 Working Days prior to the Bid due date** and on the City's Product Submittal Form available at:

<http://www.sandiego.gov/publicworks/edocref/index.shtml>

SECTION 6 - PROSECUTION, PROGRESS AND ACCEPTANCE OF WORK

6-1 CONSTRUCTION SCHEDULE AND COMMENCEMENT OF WORK. To the "WHITEBOOK", ADD the following:

1. Timelines for submittal of Job Safety Analysis (JSA) delivery and installation shall be presented by contractor at the pre-construction meeting.

2. Submittals shall be provided by the contractor for all phases of work to be completed at the pre-construction meeting. Submittals shall include but are not limited to the following:

Schedule of Work

Weko-Seal

Job Safety Analysis

Sikadur-UA Concrete Fix

Splash Zone Underwater Epoxy Paste product number 2702

6-1.1 Construction Schedule. To the "WHITEBOOK", item 22, subsection b, DELETE in its entirety and SUBSTITUTE with the following:

- b) A curve value percentage comparison between the Contract Price and the updated cash flow forecast for each Project ID included in the Contract Documents. Curve values shall be set on a scale from 0% to 100% in intervals of 5% of the Contract Time. Refer to the Sample City Invoice materials in the Contract Documents and use the format shown. Your invoice amounts shall be supported by this curve value percentage. For previous periods, use the actual values and percentages and update the curve value percentages accordingly.

ADD:

6-3.2.1.1 Environmental Document.

1. The City of San Diego has prepared a **Notice of Exemption** for **Point Loma Wastewater Treatment Plant Ocean Outfall Repair, Project No. / SCH No. 21004004**, as referenced in the Contract Appendix. You shall comply with all requirements of the **Notice of Exemption** as set forth in **Appendix A**.
2. Compliance with the City's environmental document shall be included in the Contract Price.

SECTION 7 - RESPONSIBILITIES OF THE CONTRACTOR

7-1.1 Equipment Requirement. To the "GREENBOOK", ADD the following:

1. The City will provide electrical to 20 amp 110 volt and $\frac{3}{4}$ inch potable water supply utilities for use by the contractor.

7-3 INSURANCE. To the "GREENBOOK", DELETE in its entirety and SUBSTITUTE with the following:

7-3 INSURANCE.

1. The insurance provisions herein shall not be construed to limit your indemnity obligations contained in the Contract.

7-3.1

Policies and Procedures.

1. You shall procure the insurance described below, at its sole cost and expense, to provide coverage against claims for loss including injuries to persons or damage to property, which may arise out of or in connection with the performance of the Work by you, your agents, representatives, officers, employees or Subcontractors.
2. Insurance coverage for property damage resulting from your operations is on a replacement cost valuation. The market value will not be accepted.
3. You shall maintain this insurance for the duration of this Contract and at all times thereafter when you are correcting, removing, or replacing Work in accordance with this Contract. Your liabilities under the Contract, e.g., your indemnity obligations, is not deemed limited to the insurance coverage required by this Contract.
4. The payment for insurance shall be included in the Contract Price as bid by you. Except as specifically agreed to by the City in writing, you are not entitled to any additional payment. Do not begin any Work under this Contract until you have provided and the City has approved all required insurance.
5. Policies of insurance shall provide that the City is entitled to 30 Days (10 Days for cancellation due to non-payment of premium) prior written notice of cancellation or non-renewal of the policy. Maintenance of specified insurance coverage is a material element of the Contract. Your failure to maintain or renew coverage or to provide evidence of renewal during the term of the Contract may be treated by the City as a material breach of the Contract.

7-3.2

Types of Insurance.

7-3.2.1

Commercial General Liability Insurance.

1. Commercial General Liability Insurance shall be written on the current version of the ISO Occurrence form CG 00 01 07 98 or an equivalent form providing coverage at least as broad.
2. The policy shall cover liability arising from premises and operations, XCU (explosions, underground, and collapse), independent contractors, products/completed operations, personal injury and advertising injury, bodily injury, property damage, and liability assumed under an insured's contract (including the tort liability of another assumed in a business contract).
3. There shall be no endorsement or modification limiting the scope of coverage for either "insured vs. insured" claims or contractual liability. You shall maintain the same or equivalent insurance for at least 10 years following completion of the Work.
4. All costs of defense shall be outside the policy limits. Policy coverage shall be in liability limits of not less than the following:

| <u>General Annual Aggregate Limit</u> | <u>Limits of Liability</u> |
|---|----------------------------|
| Other than Products/Completed Operations | \$2,000,000 |
| Products/Completed Operations Aggregate Limit | \$2,000,000 |
| Personal Injury Limit | \$1,000,000 |
| Each Occurrence | \$1,000,000 |

7-3.2.2 Commercial Automobile Liability Insurance.

1. You shall provide a policy or policies of Commercial Automobile Liability Insurance written on the current version of the ISO form CA 00 01 12 90 or later version or equivalent form providing coverage at least as broad in the amount of \$1,000,000 combined single limit per accident, covering bodily injury and property damage for owned, non-owned, and hired automobiles ("Any Auto").
2. All costs of defense shall be outside the limits of the policy.

7-3.3 Rating Requirements. Except for the State Compensation Insurance Fund, all insurance required by this Contract as described herein shall be carried only by responsible insurance companies with a rating of, or equivalent to, at least "A-, VI" by A.M. Best Company, that are authorized by the California Insurance Commissioner to do business in the State, and that have been approved by the City.

7-3.3.1 Non-Admitted Carriers. The City will accept insurance provided by non-admitted, "surplus lines" carriers only if the carrier is authorized to do business in the State and is included on the List of Approved Surplus Lines Insurers (LASLI list).

All policies of insurance carried by non-admitted carriers shall be subject to all of the requirements for policies of insurance provided by admitted carriers described herein.

7-3.4 Evidence of Insurance. Furnish to the City documents e.g., certificates of insurance and endorsements evidencing the insurance required herein, and furnish renewal documentation prior to expiration of this insurance. Each required document shall be signed by the insurer or a person authorized by the insurer to bind coverage on its behalf. We reserve the right to require complete, certified copies of all insurance policies required herein.

7-3.5 Policy Endorsements.

7-3.5.1 Commercial General Liability Insurance.

7-3.5.1.1 Additional Insured.

1. You shall provide at your expense policy endorsement written on the current version of the ISO Occurrence form CG 20 10 11 85 or an equivalent form providing coverage at least as broad.

2. To the fullest extent allowed by law e.g., California Insurance Code §11580.04, the policy shall be endorsed to include the City and its respective elected officials, officers, employees, agents, and representatives as additional insured.
3. The additional insured coverage for projects for which the Engineer's Estimate is \$1,000,000 or more shall include liability arising out of:
 - a) Ongoing operations performed by you or on your behalf,
 - b) your products,
 - c) your Work, e.g., your completed operations performed by you or on your behalf, or
 - d) premises owned, leased, controlled, or used by you.
4. The additional insured coverage for projects for which the Engineer's Estimate is less than \$1,000,000 shall include liability arising out of:
 - a) Ongoing operations performed by you or on your behalf,
 - b) your products, or
 - c) premises owned, leased, controlled, or used by you.

7-3.5.1.2 Primary and Non-Contributory Coverage. The policy shall be endorsed to provide that the coverage with respect to operations, including the completed operations, if appropriate, of the Named Insured is primary to any insurance or self-insurance of the City and its elected officials, officers, employees, agents and representatives. Further, it shall provide that any insurance maintained by the City and its elected officials, officers, employees, agents and representatives shall be in excess of your insurance and shall not contribute to it.

7-3.5.1.3 Project General Aggregate Limit. The policy or policies shall be endorsed to provide a Designated Construction Project General Aggregate Limit that will apply only to the Work. Only claims payments which arise from the Work shall reduce the Designated Construction Project General Aggregate Limit. The Designated Construction Project General Aggregate Limit shall be in addition to the aggregate limit provided for the products-completed operations hazard.

7-3.5.2 Commercial Automobile Liability Insurance.

7-3.5.2.1 Additional Insured. Unless the policy or policies of Commercial Auto Liability Insurance are written on an ISO form CA 00 01 12 90 or a later version of this form or equivalent form providing coverage at least as broad, the policy shall be endorsed to include the City and its respective elected officials, officers, employees, agents, and representatives as additional insured, with respect to liability arising out of automobiles owned, leased, hired or borrowed by you or on your behalf. This endorsement is limited to the obligations permitted by California Insurance Code §11580.04.

7-3.6 Deductibles and Self-Insured Retentions. You shall pay for all deductibles and self-insured retentions. You shall disclose deductibles and self-insured retentions to the City at the time the evidence of insurance is provided.

7-3.7 Reservation of Rights. The City reserves the right, from time to time, to review your insurance coverage, limits, deductibles and self-insured retentions to determine if they are acceptable to the City. The City will reimburse you, without overhead, profit, or any other markup, for the cost of additional premium for any coverage requested by the Engineer but not required by this Contract.

7-3.8 Notice of Changes to Insurance. You shall notify the City 30 Days prior to any material change to the policies of insurance provided under this Contract.

7-3.9 Excess Insurance. Policies providing excess coverage shall follow the form of the primary policy or policies e.g., all endorsements.

7-4 NOT USED. To the "GREENBOOK", DELETE in its entirety and SUBSTITUTE with the following:

7-4 WORKERS' COMPENSATION INSURANCE AND EMPLOYERS LIABILITY INSURANCE.

1. In accordance with the provisions of §3700 of the California Labor Code, you shall provide at your expense Workers' Compensation Insurance and Employers Liability Insurance to protect you against all claims under applicable state workers compensation laws. The City, its elected officials, and employees will not be responsible for any claims in law or equity occasioned by your failure to comply with the requirements of this section.

2. Limits for this insurance shall be not less than the following:

| <u>Workers' Compensation</u> | <u>Statutory Employers Liability</u> |
|------------------------------|--------------------------------------|
| Bodily Injury by Accident | \$1,000,000 each accident |
| Bodily Injury by Disease | \$1,000,000 each employee |
| Bodily Injury by Disease | \$1,000,000 policy limit |

3. By signing and returning the Contract you certify that you are aware of the provisions of §3700 of the Labor Code which requires every employer to be insured against liability for worker's compensation or to undertake self-insurance in accordance with the provisions of that code and you shall comply with such provisions before commencing the Work as required by §1861 of the California Labor Code.

7-4.1 Waiver of Subrogation. The policy or policies shall be endorsed to provide that the insurer will waive all rights of subrogation against the City and its respective elected officials, officers, employees, agents, and representatives for losses paid under the

7-4.2 Workers' Compensation Insurance for Work In, Over, or Alongside Navigable Waters. In addition to the Workers' Compensation Insurance required under the General Conditions of this contract, the you shall provide additional insurance coverage for claims brought under the Longshore and Harbor Workers' Compensation Act, the Jones Act, general maritime law, and any other federal or state laws, resulting from the your Work in, over, or alongside navigable waters.

7-6.2.1 Contractor's Responsibilities. To "GREENBOOK", ADD the following:

1. **Emergency Calls**

A supervisor OR Service Lead shall respond to emergency telephone calls within fifteen (15) minutes of the call being placed. All actions required to resolve the emergency shall be completed within four (4) hours. Emergency calls are defined as those where the Contract Administrator, or designee, states an emergency exists and notifies the Contractor's office of such emergency. Failure to take appropriate corrective action for emergencies within the time frame specified may result in termination of the contract.

2. **Non-Emergency Calls**

A supervisor or Service Lead shall respond to non-emergency calls, or emails within one (1) hour. All actions required to resolve the non-emergency issue (s) or deficiencies must be completed by the next business day unless otherwise directed by the contractor Administrator, or designee. Failure to respond and/or take appropriate corrective action within the time frame specified may result in termination of the contract.

7-8.1 General. To the "WHITEBOOK", ADD the following:

2. The Contractor shall be aware of the environment while working at the site under contract which means keeping the site clean, recycling when possible, turning of lights if you are the last one to leave, and reporting any environmental issues. Please contact the Facility Environmental Coordinator at the telephone number (858) 292-6482 to report any environmental issues or to obtain additional information regarding this policy.

All removed material will be recycled and placed onsite in City Bins. In addition, proper stewardship regarding the application of paint products, storage and disposal post-consumption will adhere to an environmentally sound and cost-effective manner.

7-10.4.1 Work Site Safety. To the "WHITEBOOK", ADD the following:

1. The Contractor shall provide a Job Safety Analysis (JSA) for review by the City. The JSA shall outline the sequence of the work, equipment that will be used, identify hazards that may exist or may be created and what procedures and/or safety equipment will be used to eliminate or reduce these hazards. A job specific, Scope of Work, JSA shall be prepared and submitted to the City two weeks in advance of the start of work. The name and qualifying documents of the "Competent Person" assigned to this project will be included in the JSA.

2. Any and all employees of the Contractor or Sub-contractor(s) who will be working on site at the PLWWTP shall attend a mandatory "Site Specific Safety Training Class" provided by the City Operations staff. This on-half (1/2) hour maximum class will be held at the PLWWTP Engineering Building Conference Room, on a date and time convenient for both parties.

7-13.4 Contractor Standards and Pledge of Compliance. To the "WHITEBOOK", DELETE in its entirety and SUBSTITUTE with the following:

1. The Contract is subject to City's Municipal Code §22.3004 as amended 10/29/13 by ordinance O-20316.
2. You shall complete a Pledge of Compliance attesting under penalty of perjury that you complied with the requirements of this section.
3. You shall ensure that all Subcontractors complete a Pledge of Compliance attesting under penalty of perjury that they complied with the requirements of this section.
4. You may access the Pledge of Compliance at:
http://www.sandiego.gov/purchasing/pdf/contractor_standards_questionnaire.pdf
5. You shall require in each subcontract that the Subcontractor shall abide by the provisions of the City's Municipal Code §22.3004. A sample provision is as follows:

"Compliance with San Diego Municipal Code §22.3004: The Subcontractor acknowledges that it is familiar with the requirements of San Diego Municipal Code §22.3004 ("Contractor Standards"), and agrees to comply with requirements of that section. The Subcontractor further agrees to complete the Pledge of Compliance, incorporated herein by reference."

**ADD:
7-13.8**

Equal Pay Ordinance.

1. You shall comply with the Equal Pay Ordinance (EPO) codified in the San Diego Municipal Code (SDMC) in section 22.4801 through 22.4809, unless compliance is not required based on an exception listed in SDMC section 22.4804.
2. You shall require all of your Subcontractors to certify compliance with the EPO in their written subcontracts.
3. You shall post a notice informing your employees of their rights under the EPO in the workplace or job site.
4. By signing this Contract with the City of San Diego, you acknowledge the EPO requirements and pledge ongoing compliance with the requirements of SDMC Division 48, section 22.4801 et seq., throughout the duration of this Contract.

7-20 ELECTRONIC COMMUNICATION. To the "WHITEBOOK", ADD the following:

2. Virtual Project Manager shall be used on this Contract.

7-21.1 General. To the "WHITEBOOK", item 3, DELETE in its entirety and SUBSTITUTE with the following:

3. During the construction phase of projects, the minimum waste management reduction goal is 90% of the inert material (a material not subject to decomposition such as concrete, asphalt, brick, rock, block, dirt, metal, glass, and etc.) and 65% of the remaining project waste. You shall provide appropriate documentation, including a Waste Management Form attached as an appendix, and evidence of recycling and reuse of materials to meet the waste reduction goals specified.

**ADD:
7-23**

AFTER HOURS ACCESS TO JOB SITE.

1. After-hours Access

After-hours (5pm-5am) access to the PLWWTP is controlled by the US Navy Security Gate at the end of Catalina Boulevard. Information requested by the US Navy for all Contractor and Subcontractor personnel as well as vehicle information will be required two (2) weeks in advance of the start of work to allow after-hours access to the plant. This information may include, but shall not be limited to: Names, Birthdates, Driver's License Information, last 4 digits of Social Security Numbers, and verification of insurance.

2. Contractor Staff Reporting Procedures.

Contractor personnel, including all supervisors conducting inspections, shall sign in upon reporting for work and shall sign out prior to leaving work on a log provided by the Contract Administrator, or designee. Contractor personnel are to sign in and out based on actual arrival and departure times versus scheduled times. Supervisors shall write "Supervisor" beside their name. The log will be kept in a designated area identified by the Contract Administrator, or designee.

3. Security Precautions

Contractor personnel shall not allow anyone on the premises unless that person is specifically assigned by the Contractor to perform work at the PLWWTP facility. This rule will be strictly enforced and non-compliance shall be cause for termination of the contract.

**ADD:
9-3.7**

Compensation Adjustments for Price Index Fluctuations. To the "WHITEBOOK" ADD the following:

5. This Contract is not subject to the provisions of The "WHITEBOOK" for Compensation Adjustments for Price Index Fluctuations for paving asphalt.

ADD:

SECTION 318 – OUTFALL REPAIR

318.1

REPAIR PROCESS. Repairs will be conducted inside the pipe between 2:00 AM and 5:00 AM for as many nights as are required to complete the scope of work. The contractor may mobilize/demobilize onsite each day before and after this time frame. The phasing of work activities should be made in consideration of the operational difficulty to hold the flow at PLWWTP and any repair effort should be coordinated with PLWWTP operations as the windows of time available to accomplish the repairs is limited. The operation window will provide a safe diving time based on consultation with City staff. The divers will enter the outfall as soon as the flow is subsided and is safe to enter. A crane with basket will be used to hoist the divers into the outfall through the vortex structure. The City will be responsible for removing the Vortex lid and installing a temporary wood lid before the work begins. The contractor shall remove and replace the temporary lid at the beginning and end of each shift. The City will reinstall the permanent Vortex lid after completion of the work.

The repair work shall include;

- A. Removal of broken and loose anodes in the steel pipe transition segment of the ocean outfall. Some of the twelve (12) 3" x 7' long anodes have come loose and are damaged. Any anodes still tightly secured to the pipe can be left in place. This Scope of Work (SOW) covers the removal of up to 6 anodes located between the bottom of the Vortex elbow and station 4+50.
- B. Remove the accumulated debris and damaged Weko-Seal at station 3+27 and install a new Weko-Seal to cover the 7/8 inch joint gap. The damaged Weko-Seal is 10-inch to 12-inch in width, and there is only one band left on the downstream side. Installation shall be performed by authorized installer.
- C. Patch the concrete pipe joint gaps at station 3+05 (open void in the pipe at 12 o' clock, 12-inch long, 1.25-inch long, 4-inch deep, with sand and mud trapped), utilizing different materials that can be monitored for performance at the next inspection in 2021. Repairs shall be made with one each of the following; Sikadur-UA Concrete Fix and Splash Zone Underwater Epoxy Paste product number 2702.
- D. Measure the size of the spalled area at station 7+10 and 12+40 so they can be monitored for changes during next inspection in 2021. Contractor shall measure the depth of the spalling in one foot increments in length and width at these locations.

EQUAL OPPORTUNITY CONTRACTING PROGRAM (EOCP) SECTION A – GENERAL REQUIREMENTS

4.1

Nondiscrimination in Contracting Ordinance. To the "WHITEBOOK", subsection 4.1.1, paragraph (2), sentence (1), DELETE in its entirety and SUBSTITUTE with the following:

You shall not discriminate on the basis of race, gender, gender expression, gender identity, religion, national origin, ethnicity, sexual orientation, age, or disability in the solicitation, selection, hiring, or treatment of subcontractors, vendors, or suppliers.

END OF SUPPLEMENTARY SPECIAL PROVISIONS (SSP)

SUPPLEMENTARY SPECIAL PROVISIONS
APPENDICES

APPENDIX A
NOTICE OF EXEMPTION

NOTICE OF EXEMPTION

(Check one or both)

TO: Recorder/County Clerk
P.O. Box 1750, MS A-33
1600 Pacific Hwy, Room 260
San Diego, CA 92101-2400

FROM: City of San Diego
Public Works Department
525 B Street, Suite 750, MS 908A
San Diego, CA 92101

Office of Planning and Research
1400 Tenth Street, Room 121
Sacramento, CA 95814

Project Name: Point Loma Wastewater Treatment Plant Ocean Outfall Repair **Project No. / SCH No.:** 21004004

Project Location-Specific: Point Loma Wastewater Treatment Plant Ocean Outfall (1902 Gatchell Road)

Project Location-City/County: San Diego/San Diego

Description of nature and purpose of the Project: Perform repair work on the Point Loma Ocean Outfall (PLOO), a 4.5-mile long, 108-inch diameter reinforced concrete pipe (RCP), based on the results of a 2016 outfall inspection. Repairs will include: removal of broken or loose anodes within the steel pipe transition segment of the ocean outfall, removal of accumulated debris, replacement of a damaged Weko-Seal, patching concrete pipe joint gaps, and measurement of the size of spalled areas to better monitor changes during the next outfall inspection. The outfall will be accessed by divers through the PLOO vortex structure. All work related to this outfall repair will comply with the conditions and constraints of the Point Loma Wastewater Treatment Plant's modified NPDES Permit #CA0107409, as applicable. Work will be contained within the PLOO structure and thus no impacts to environmentally sensitive lands (ESL) will occur.

Name of Public Agency Approving Project: City of San Diego

Name of Person or Agency Carrying Out Project: City of San Diego Public Works Department,
Contact: Jerry Jakubauskas; Phone: (619) 533-3755
525 B Street, Suite 750 (MS 908A), San Diego, CA

Exempt Status: (CHECK ONE)

- Ministerial (Sec. 21080(b)(1); 15268);
- Declared Emergency (Sec. 21080(b)(3); 15269(a));
- Emergency Project (Sec. 21080(b)(4); 15269 (b)(c))
- Categorical Exemption: 15301(b) [Existing Facilities]

Reasons why project is exempt: The City of San Diego conducted an environmental review which determined that the project meets the categorical exemption criteria set forth in CEQA State Guidelines, Section 15301(b) [Existing Facilities] which allows for the operation, repair, maintenance, or minor alternation of existing public or private facilities including facilities of both investor and publicly owned utilities used to provide electric power, natural gas, sewerage, or other public utility services; involving negligible or no expansion of use beyond that existing at the time of the lead agency's determination; and where the exceptions listed in Section 15300.2 would not apply.

Lead Agency Contact Person: Jerry Jakubauskas

Telephone: (619) 533-3755

If filed by applicant:

1. Attach certified document of exemption finding.
2. Has a notice of exemption been filed by the public agency approving the project? Yes No

Revised May 2016

It is hereby certified that the City of San Diego has determined the above activity to be exempt from CEQA

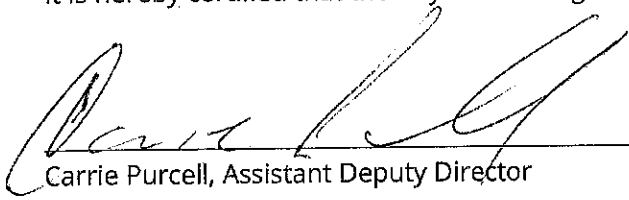

Carrie Purcell, Assistant Deputy Director

9/8/2017
Date

Check One:

Signed By Lead Agency

Signed by Applicant

Date Received for Filing with County Clerk or OPR:

APPENDIX B
INTENTIONALLY LEFT BLANK

APPENDIX C

MATERIALS TYPICALLY ACCEPTED BY CERTIFICATE OF COMPLIANCE

MATERIALS TYPICALLY ACCEPTED BY CERTIFICATE OF COMPLIANCE

1. Soil amendment
2. Fiber mulch
3. PVC or PE pipe up to 16 inch diameter
4. Stabilizing emulsion
5. Lime
6. Preformed elastomeric joint seal
7. Plain and fabric reinforced elastomeric bearing pads
8. Steel reinforced elastomeric bearing pads
9. Waterstops (Special Condition)
10. Epoxy coated bar reinforcement
11. Plain and reinforcing steel
12. Structural steel
13. Structural timber and lumber
14. Treated timber and lumber
15. Lumber and timber
16. Aluminum pipe and aluminum pipe arch
17. Corrugated steel pipe and corrugated steel pipe arch
18. Structural metal plate pipe arches and pipe arches
19. Perforated steel pipe
20. Aluminum underdrain pipe
21. Aluminum or steel entrance tapers, pipe downdrains, reducers, coupling bands and slip joints
22. Metal target plates
23. Paint (traffic striping)
24. Conductors
25. Painting of electrical equipment
26. Electrical components
27. Engineering fabric
28. Portland Cement
29. PCC admixtures
30. Minor concrete, asphalt
31. Asphalt (oil)
32. Liquid asphalt emulsion
33. Epoxy

APPENDIX D

SAMPLE CITY INVOICE WITH SPEND CURVE

Sample Project Spend Curve

Sample Date Entries Required

Incremental Curve Value
Duration % Increment

| | | | | | | | | | | | | | | | | | | | | |
|------|------|------|------|------|------|------|------|------|------|------|------|------|------|------|------|------|------|------|------|------|
| 0.0% | 3.5% | 3.5% | 3.5% | 3.5% | 3.5% | 3.5% | 3.5% | 3.5% | 3.5% | 3.5% | 6.5% | 6.5% | 6.5% | 6.5% | 6.5% | 6.5% | 6.5% | 6.5% | 6.5% | 6.5% |
| 0% | 5% | 10% | 15% | 20% | 25% | 30% | 35% | 40% | 45% | 50% | 55% | 60% | 65% | 70% | 75% | 80% | 85% | 90% | 95% | 100% |

Sample Screenshot from Primavera P6

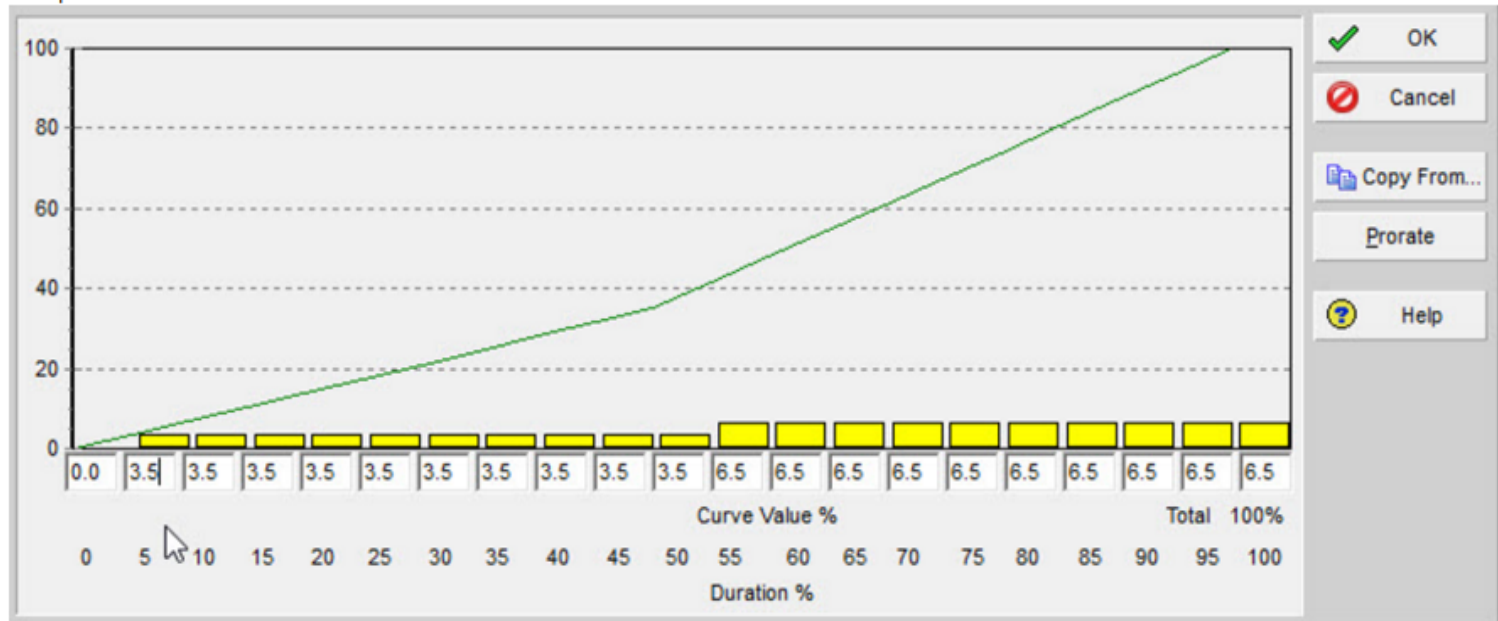

APPENDIX E
LOCATION MAP

Point Loma Wastewater Treatment Plant
Ocean Outfall Repair

SENIOR ENGINEER
 Jong Choi
 619-533-5493

PROJECT MANAGER
 Manuel Gonzalez
 619-533-3471

FOR QUESTIONS ABOUT THIS PROJECT
 Call: 619-533-4207
 Email: engineering@sandiego.gov

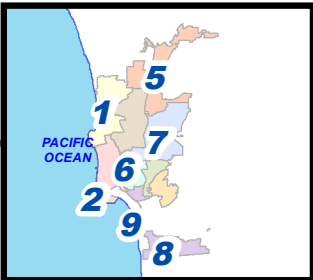

Legend

 Limits of Work

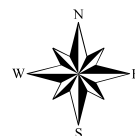

THIS MAP/DATA IS PROVIDED WITHOUT WARRANTY OF ANY KIND, EITHER EXPRESS OR IMPLIED, INCLUDING, BUT NOT LIMITED TO, THE IMPLIED WARRANTIES OR MERCHANTABILITY AND FITNESS FOR A PARTICULAR PURPOSE. Note: This product may contain information reproduced with permission granted by RAND MCNALLY & COMPANY to SanGIS. This map is copyrighted by RAND MCNALLY & COMPANY. It is unlawful to copy or reproduce all or any part thereof, whether for personal use or resale, without the prior, written permission of RAND MCNALLY & COMPANY.

APPENDIX F
AS-BUILT AND REFERENCES



Vortex Location

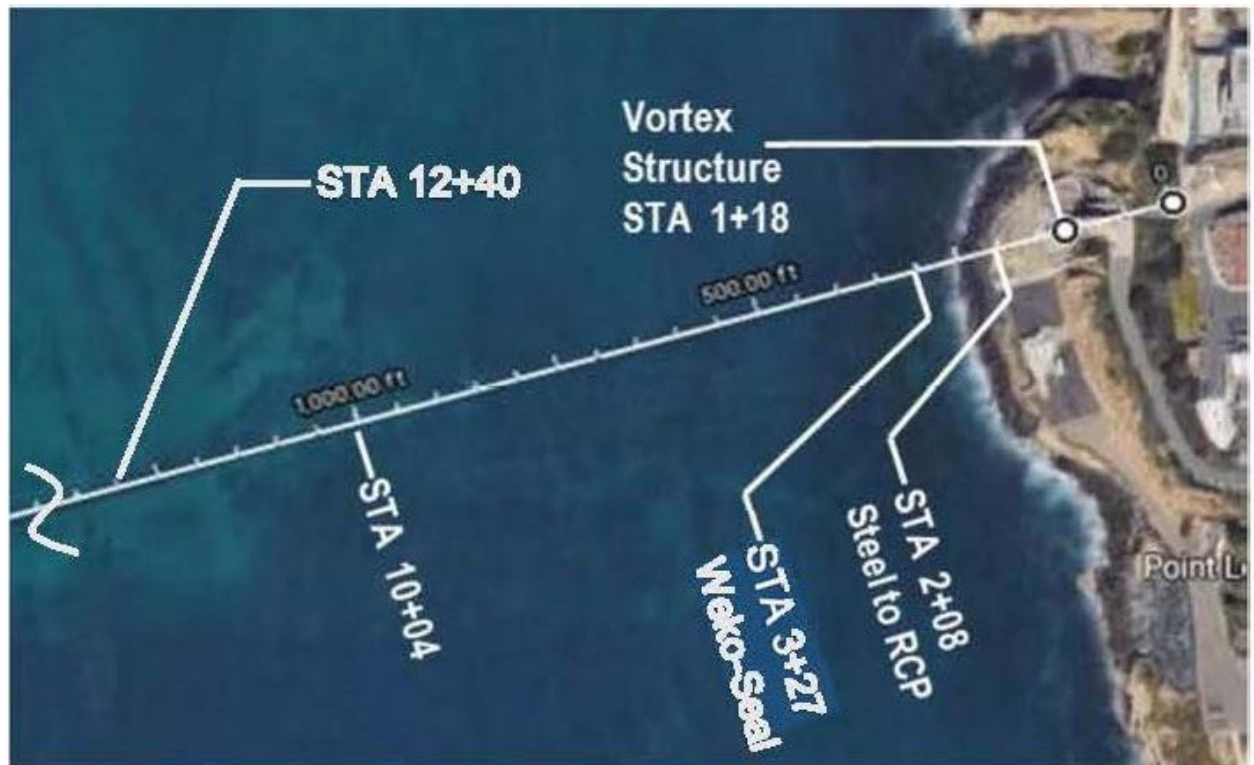

Outfall Stationing

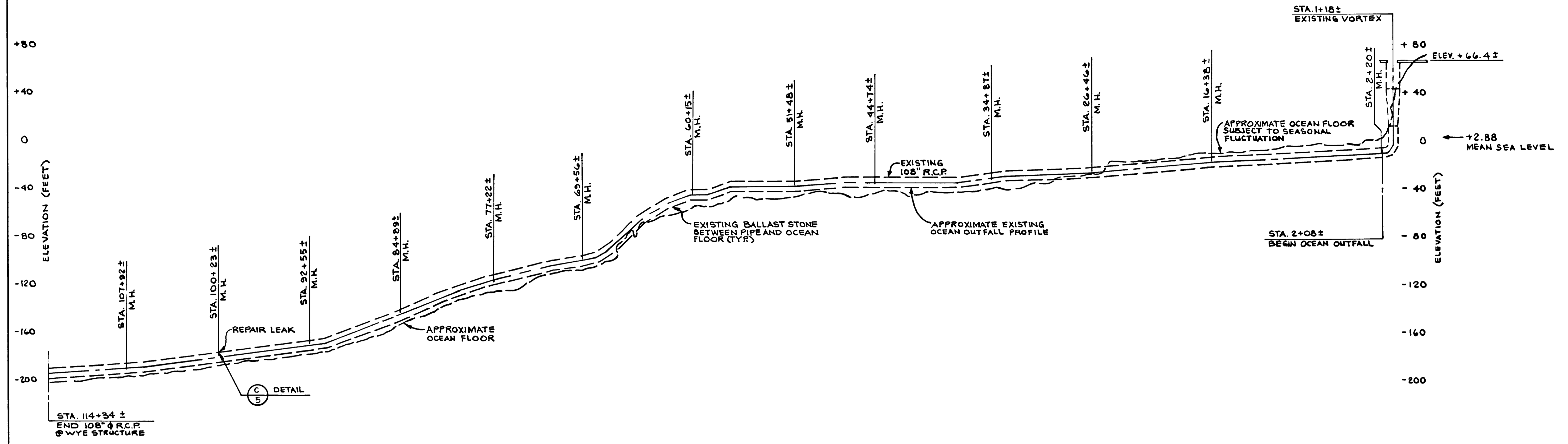

PROFILE
 SCALE: HORIZ. 1" = 400'
 VERT. 1" = 40'

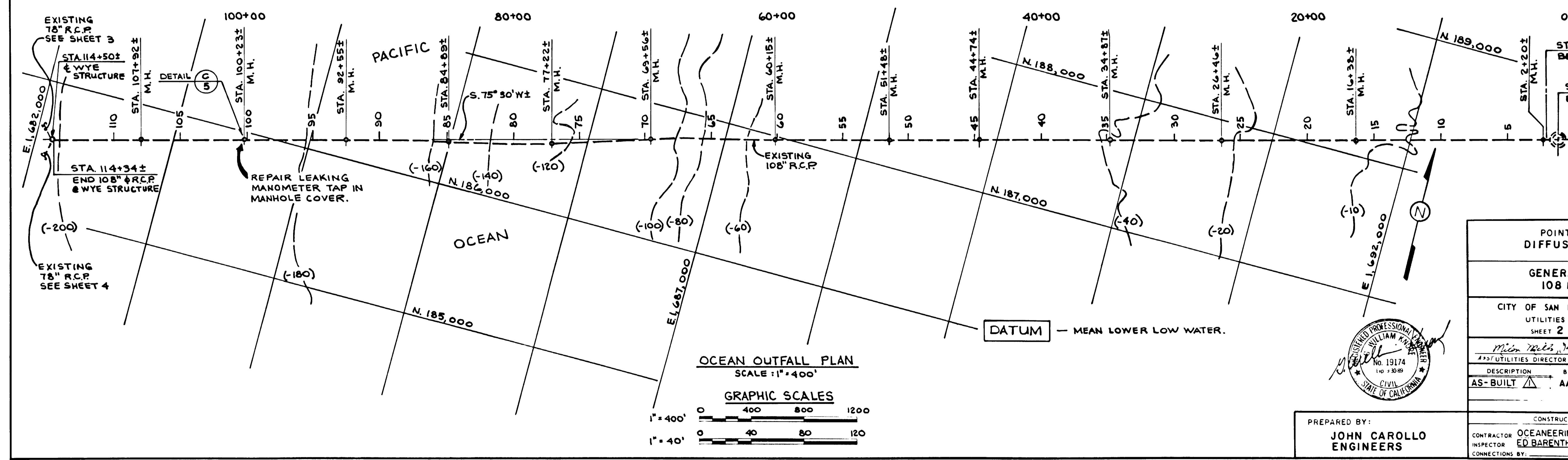

OCEAN OUTFALL PLAN
 SCALE: 1" = 400'

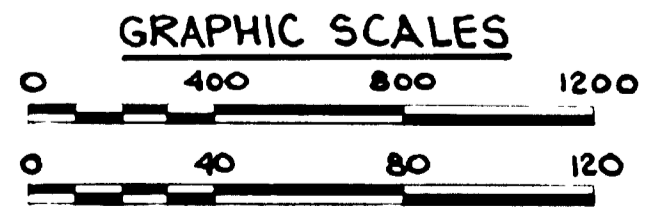

| | |
|--|---|
| POINT LOMA OCEAN OUTFALL DIFFUSER LEG MODIFICATIONS | |
| GENERAL PLAN AND PROFILE 108 INCH OCEAN OUTFALL | |
| CITY OF SAN DIEGO, CALIFORNIA UTILITIES DEPARTMENT SHEET 2 OF 5 SHEETS | E.W.O. 170081 U.W.O. 170081 |
| <i>Milton Wells</i> ASST. UTILITIES DIRECTOR DATE: 1-1-87 | ENGINEERING SUPERINTENDENT <i>John H. Havelly</i> DESIGN ENGINEER DATE: 2-5-87 |
| DESCRIPTION: AS-BUILT BY: AA APPROVED: <i>Ed Barentin</i> FILMED: | CONTROL CERTIFICATION _____ LAWBERT COORDINATES |
| PREPARED BY: JOHN CAROLLO ENGINEERS | CONSTRUCTION RECORD CONTRACTOR: OCEANEERING INSPECTOR: ED BARENTIN DATE STARTED: 8-8-87 DATE COMPLETED: 8-18-87 |
| 23618-2-D | |



AS-BUILT

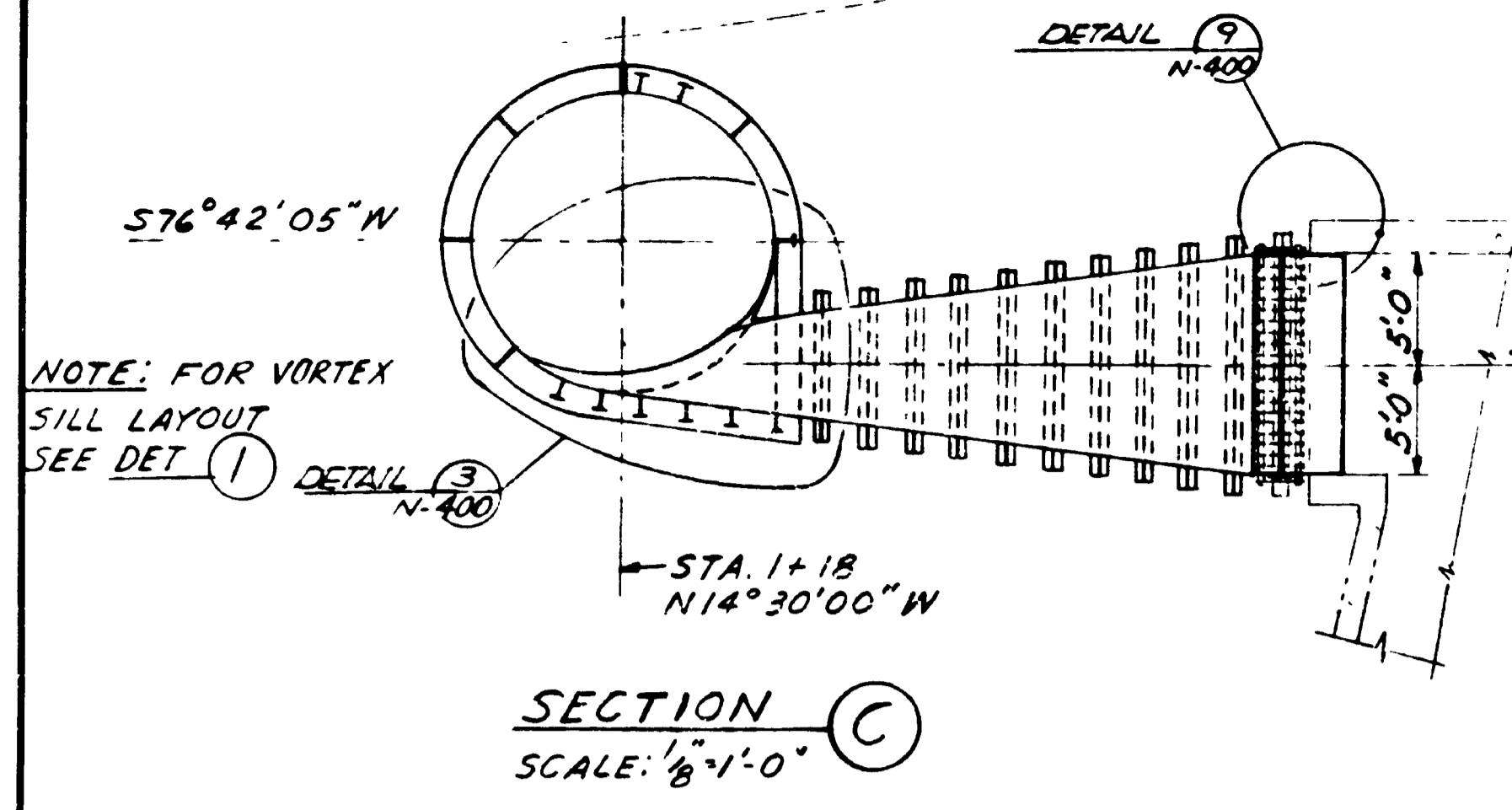

NOTE: FOR VORTEX SILL LAYOUT SEE DET. 1

SECTION C
SCALE: 1/8" = 1'-0"

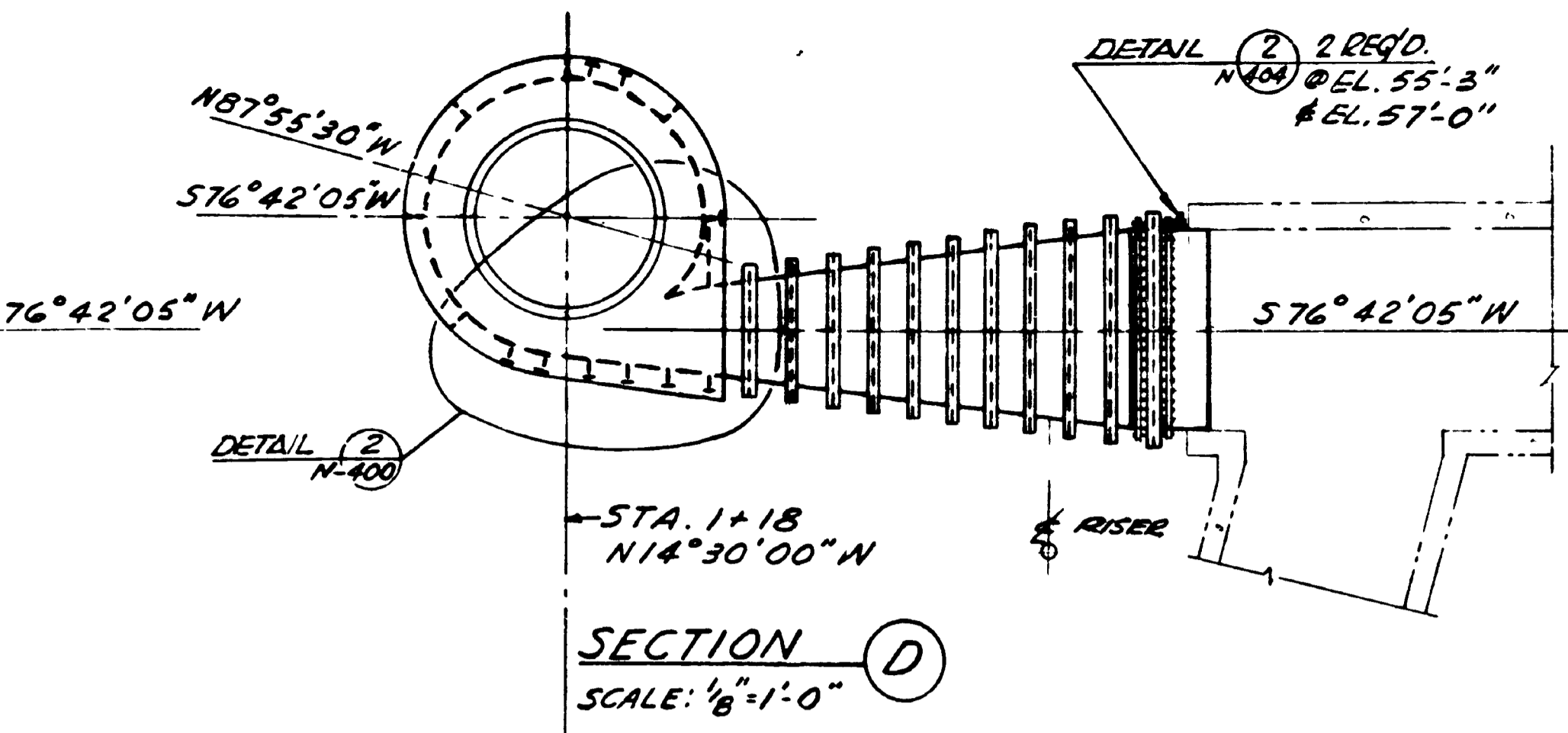

SECTION D
SCALE: 1/8" = 1'-0"

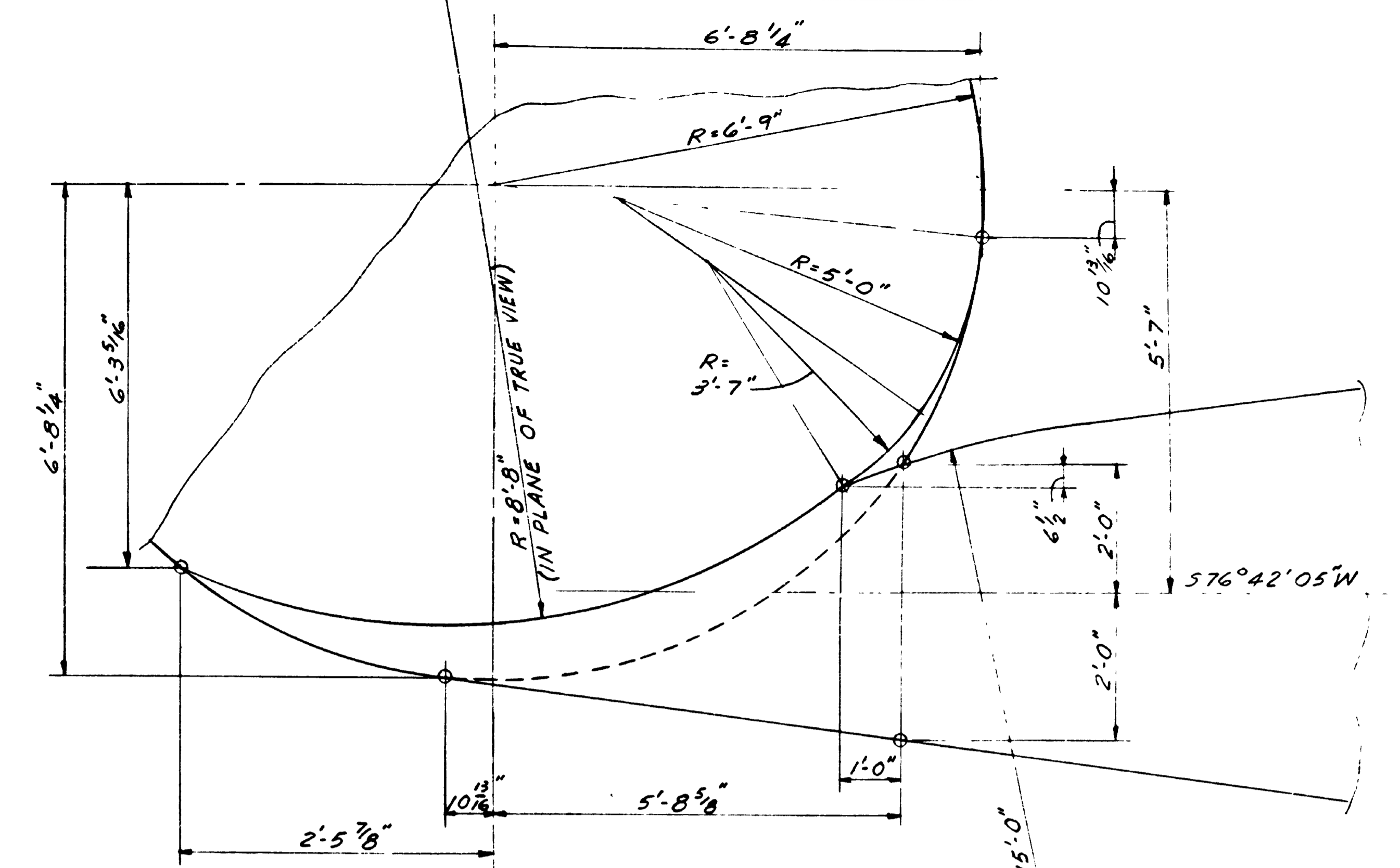

VORTEX SILL LAYOUT-DETAIL 1
NO SCALE

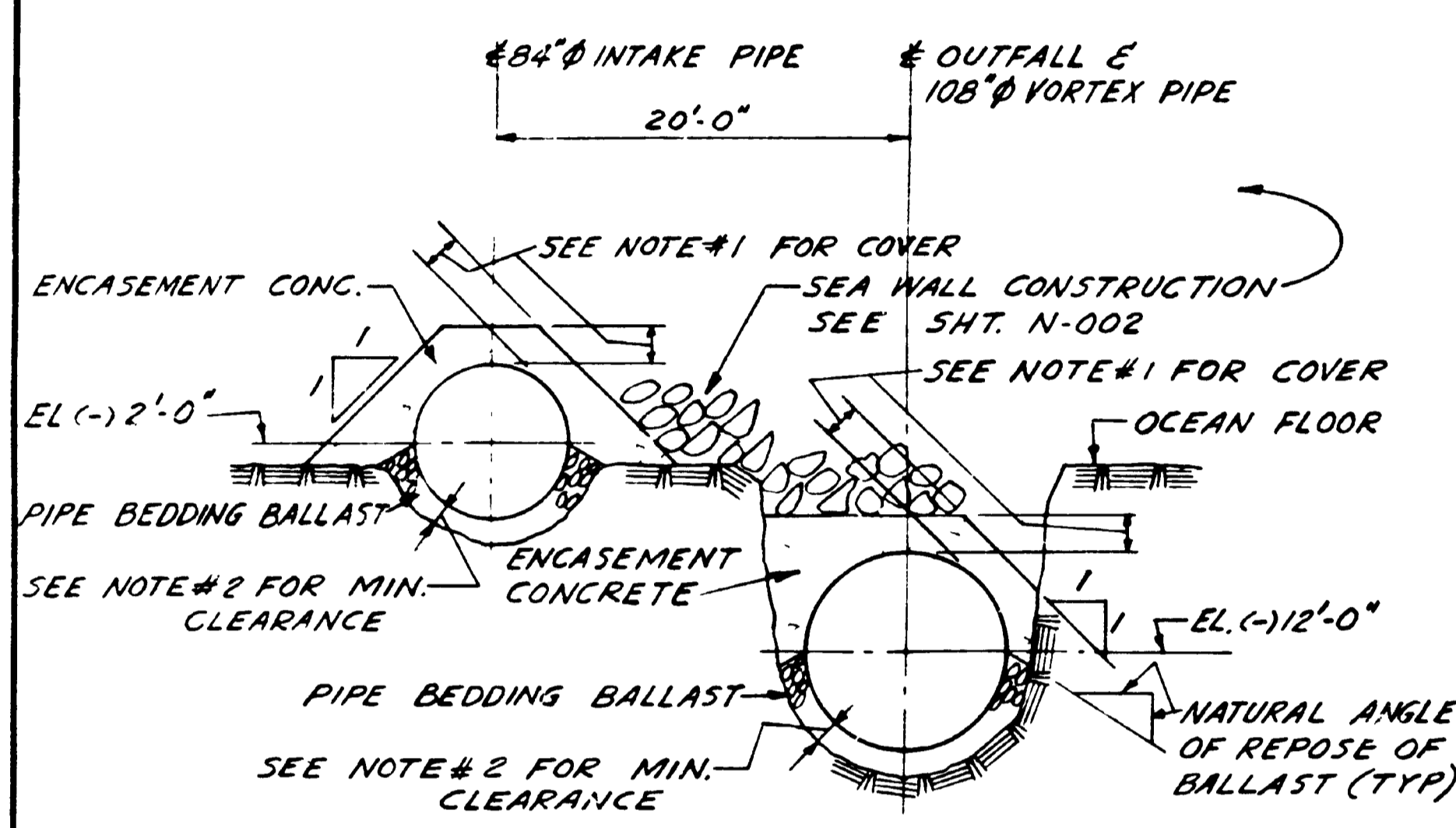

CONSTRUCTION SECTION E
SCALE: 1/8" = 1'-0"

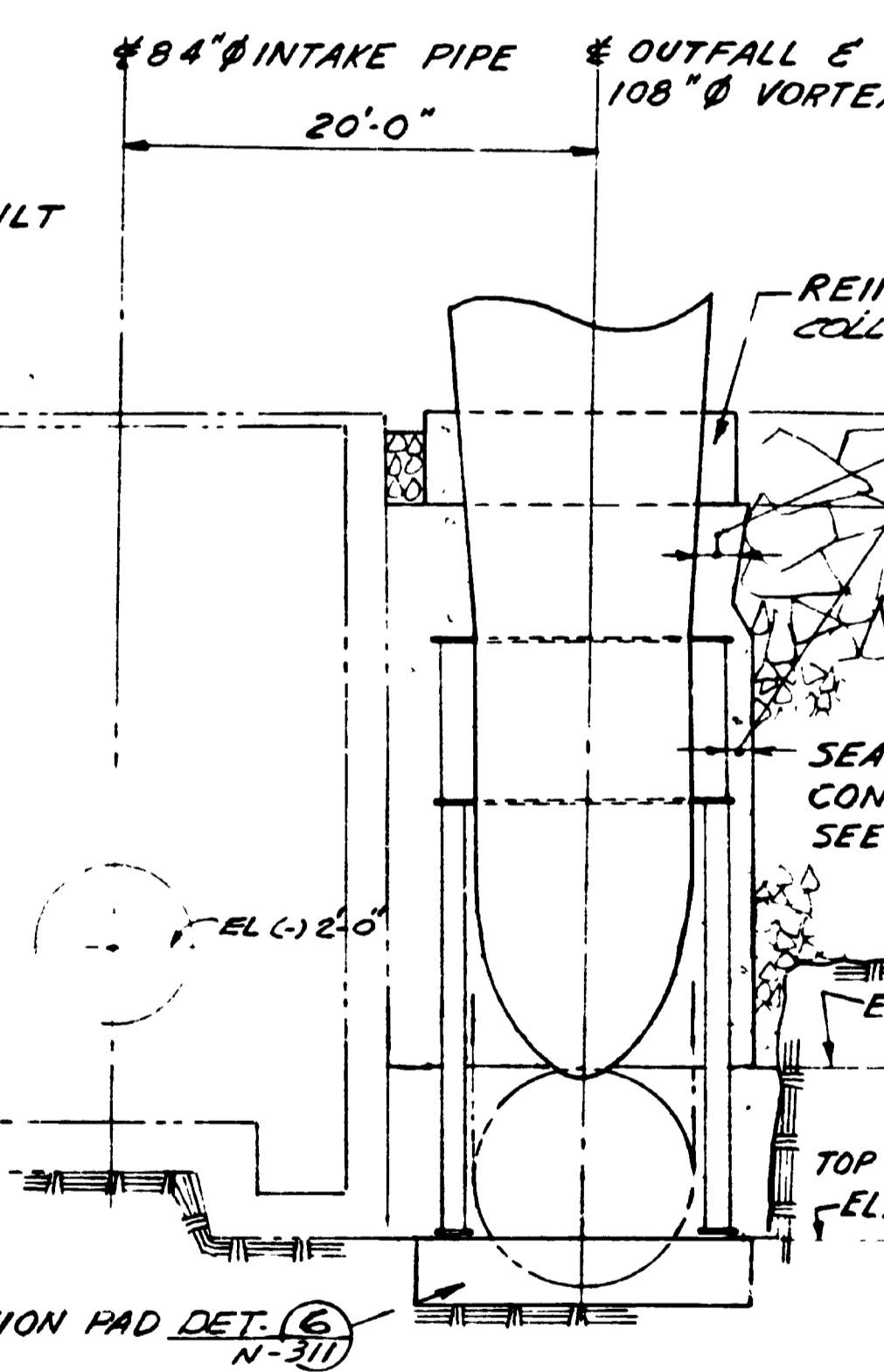
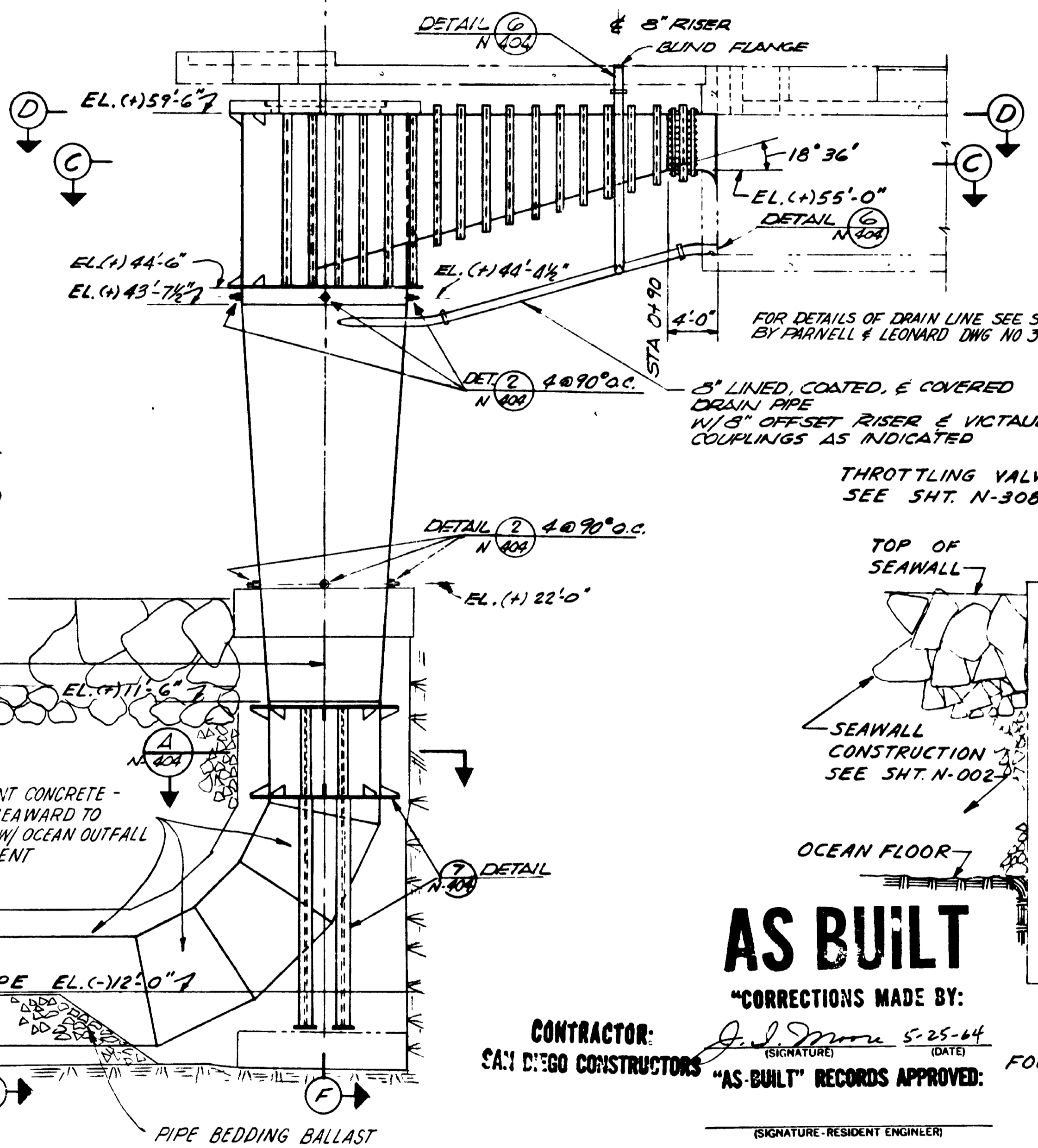

CONSTRUCTION SECTION F
SCALE: 1/8" = 1'-0"

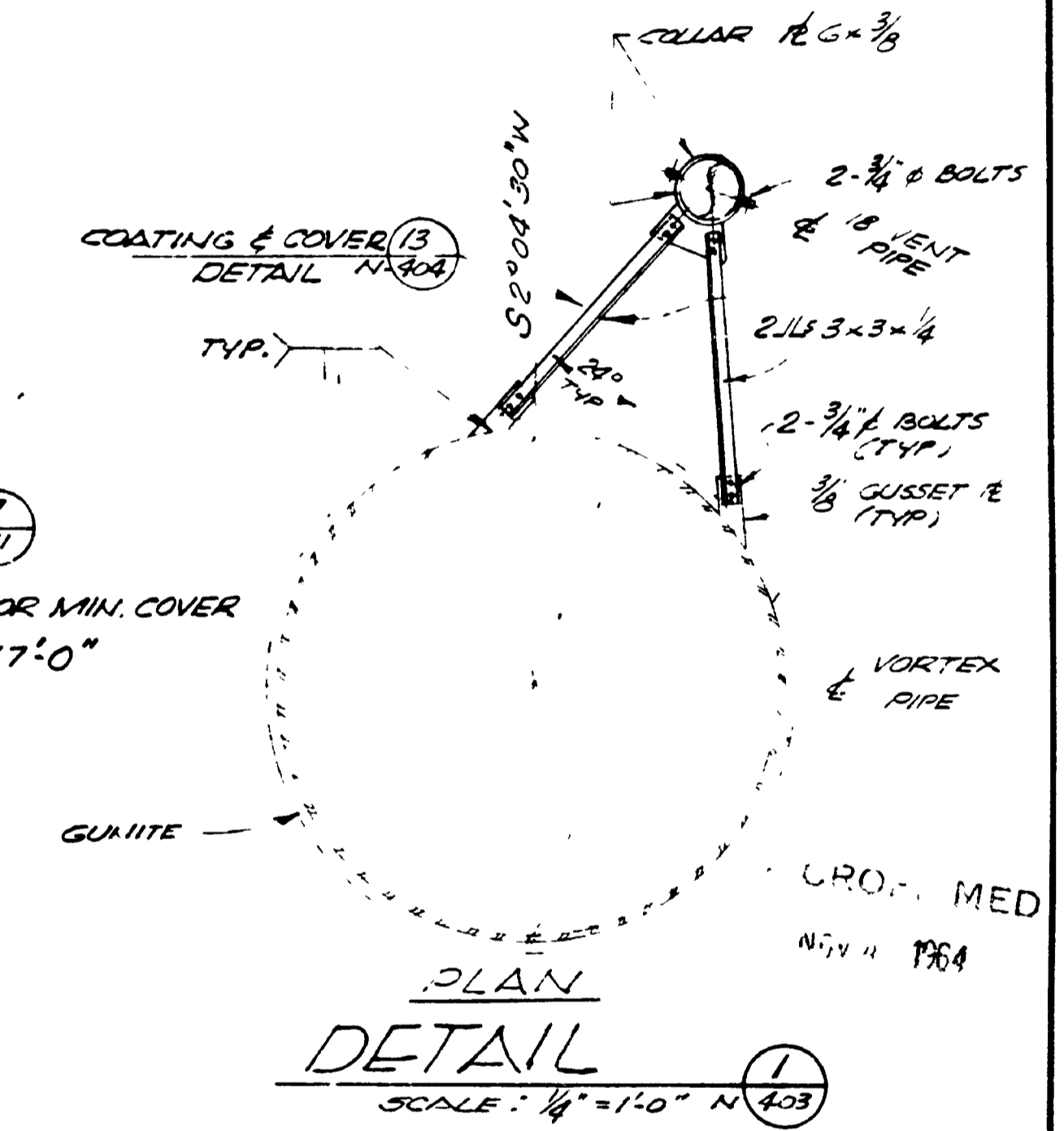

PLAN DETAIL 1
SCALE: 1/4" = 1'-0" N-403

AS BUILT

CONTRACTOR: SAN DIEGO CONSTRUCTORS
"AS-BUILT" RECORDS APPROVED:

- NOTES:
- ENCASEMENT CONCRETE COVER:
 - PIPE BARREL — 2'-0" MIN.
 - PROJECTIONS FROM BARREL — 1'-0" MIN.
 - MINIMUM CLEARANCE FROM PIPE BARREL TO LINE OF MINIMUM EXCAVATION SHALL NOT BE LESS THAN 1'-6".

SECTION B
SCALE: 1/8" = 1'-0"

FOR DETAILS OF VORTEX INLET & PIPE SEE SHOP DWG. PREP'D BY MOSHER STEEL CO. DWG NO. 4002A SHEET E1X REV 4, 2 REV 4, 4 REV 5, 8 REV 1 & 9 REV 1

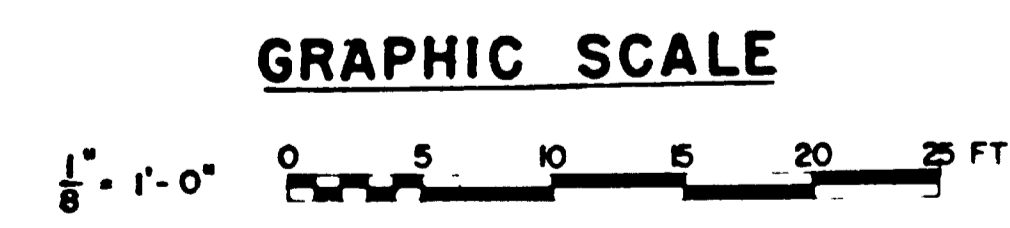

| REVISION | DATE | DESCRIPTION |
|--|------|-------------------------------------|
| CITY OF SAN DIEGO SEWAGE COLLECTION, TREATMENT, & DISPOSAL SYSTEM | | |
| HOLMES & NARVER - MONTGOMERY | | |
| HOLMES & NARVER INC 828 SO FIGUEROA ST. LOS ANGELES 17, CALIF | | J. M. MONTGOMERY CONSULTING ENGR |
| OCEAN OUTFALL INTAKE VORTEX PIPE PLANS & ELEVATIONS | | |
| SUBMITTED JUNE 15, 1964 | | |
| DESIGNED BY | DATE | SCALE |
| DRAWN BY | DATE | PROJECT NO. |
| CHECKED BY | DATE | DRAWING NO. |
| | | SH NO. |
| | | AS SHOWN |
| | | 11054-19-D |
| | | N-401 |
| | | SHT 19 OF 24 SHTS |

ATTACHMENT F
INTENTIONALLY LEFT BLANK

ATTACHMENT G
CONTRACT AGREEMENT

CONTRACT AGREEMENT

CONSTRUCTION CONTRACT

This contract is made and entered into between THE CITY OF SAN DIEGO, a municipal corporation, herein called "City", and De La Fuente Construction, Inc., herein called "Contractor" for construction of **POINT LOMA OCEAN OUTFALL REPAIR**; Bid No. **L-18-1710-DBB-1**; in the amount of **One Hundred Eighty Six Thousand Seven Hundred Seventy Seven Dollars and Zero Cents (\$186,777.00)**, which is comprised of the Base Bid.

IN CONSIDERATION of the payments to be made hereunder and the mutual undertakings of the parties hereto, City and Contractor agree as follows:

1. The following are incorporated into this contract as though fully set forth herein:
 - (a) The attached Faithful Performance and Payment Bonds.
 - (b) The attached Proposal included in the Bid documents by the Contractor.
 - (c) Reference Standards listed in the Instruction to Bidders and the Supplementary Special Provisions (SSP).
 - (d) That certain documents entitled **POINT LOMA OCEAN OUTFALL REPAIR**, on file in the office of Public Works Contracts as Document No. **21004004**, as well as all matters referenced therein.
2. The Contractor shall perform and be bound by all the terms and conditions of this contract and in strict conformity therewith shall perform and complete in a good and workmanlike manner **POINT LOMA OCEAN OUTFALL REPAIR**, Bid No. **L-18-1710-DBB-1**, San Diego, California.
3. For such performances, the City shall pay to Contractor the amounts set forth at the times and in the manner and with such additions or deductions as are provided for in this contract, and the Contractor shall accept such payment in full satisfaction of all claims incident to such performances.
4. No claim or suit whatsoever shall be made or brought by Contractor against any officer, agent, or employee of the City for or on account of anything done or omitted to be done in connection with this contract, nor shall any such officer, agent, or employee be liable hereunder.
5. This contract is effective as of the date that the Mayor or designee signs the agreement.

CONTRACT AGREEMENT (continued)

IN WITNESS WHEREOF, this Agreement is signed by the City of San Diego, acting by and through its Mayor or designee, pursuant to Municipal Code §22.3102 authorizing such execution.

THE CITY OF SAN DIEGO

APPROVED AS TO FORM

Mara W. Elliott, City Attorney

By Brittany Friedenreich

By Leone

Print Name: Brittany Friedenreich
Contract Specialist
Public Works Department

Print Name: Christine Leone
Deputy City Attorney

Date: 4/20/18

Date: 4/24/18

CONTRACTOR

By [Signature]

Print Name: Jorge E. Diaz De La Fuente

Title: President

Date: 3/27/18

City of San Diego License No.: B2010035758

State Contractor's License No.: 919666

DEPARTMENT OF INDUSTRIAL RELATIONS (DIR) REGISTRATION NUMBER: 1000043346

CERTIFICATIONS AND FORMS

The Bidder / Proposer, by submitting its electronic bid or proposal, agrees to and certifies under penalty of perjury under the laws of the State of California, that the certifications, forms and affidavits submitted as part of this submission are true and correct.

BIDDER'S GENERAL INFORMATION

To the City of San Diego:

Pursuant to "Notice Inviting Bids", specifications, and requirements on file with the City Clerk, and subject to all provisions of the Charter and Ordinances of the City of San Diego and applicable laws and regulations of the United States and the State of California, the undersigned hereby proposes to furnish to the City of San Diego, complete at the prices stated herein, the items or services hereinafter mentioned. The undersigned further warrants that this bid is not made in the interest of, or on behalf of, any undisclosed person, partnership, company, association, organization, or corporation; that the bid is genuine and not collusive or sham; that the bidder has not directly or indirectly induced or solicited any other bidder to put in a false or sham bid, and has not directly or indirectly colluded, conspired, connived, or agreed with any bidder or anyone else to put in a sham bid, or that anyone shall refrain from bidding; that the bidder has not in any manner, directly or indirectly, sought by agreement, communication, or conference with anyone to fix the bid price of the bidder or any other bidder, or to fix any overhead, profit, or cost element of the bid price, or of that of any other bidder, or to secure any advantage against the public body awarding the contract of anyone interested in the proposed contract; that all statements contained in the bid are true; and, further, that the bidder has not, directly or indirectly, submitted his or her bid price or any breakdown thereof, or the contents thereof, or divulged information or data relative thereto, or paid, and will not pay, any fee to any corporation, partnership, company, association, organization, bid depository, or to any member or agent thereof to effectuate a collusive or sham bid.

The undersigned bidder(s) further warrants that bidder(s) has thoroughly examined and understands the entire Contract Documents (plans and specifications) and the Bidding Documents therefore, and that by submitting said Bidding Documents as its bid proposal, bidder(s) acknowledges and is bound by the entire Contract Documents, including any addenda issued thereto, as such Contract Documents incorporated by reference in the Bidding Documents.

**NON-COLLUSION AFFIDAVIT TO BE EXECUTED BY BIDDER AND SUBMITTED WITH BID
UNDER 23 UNITED STATES CODE 112 AND PUBLIC CONTRACT CODE 7106**

State of California

County of San Diego

The bidder, being first duly sworn, deposes and says that he or she is authorized by the party making the foregoing bid that the bid is not made in the interest of, or on behalf of, any undisclosed person, partnership, company, association, organization, or corporation; that the bid is genuine and not collusive or sham; that the bidder has not directly or indirectly induced or solicited any other bidder to put in a false or sham bid, and has not directly or indirectly colluded, conspired, connived, or agreed with any bidder or anyone else to put in a sham bid, or that anyone shall refrain from bidding; that the bidder has not in any manner, directly or indirectly, sought by agreement, communication, or conference with anyone to fix the bid price of the bidder or any other bidder, or to fix any overhead, profit, or cost element of the bid price, or of that of any other bidder, or to secure any advantage against the public body awarding the contract of anyone interested in the proposed contract; that all statements contained in the bid are true; and further, that the bidder has not, directly or indirectly, submitted his or her bid price or any breakdown thereof, or the contents thereof, or divulged information or data relative thereto, or paid, and will not pay, any fee to any corporation, partnership, company association, organization, bid depository, or to any member or agent thereof to effectuate a collusive or sham bid.

CONTRACTOR CERTIFICATION

DRUG-FREE WORKPLACE

I hereby certify that I am familiar with the requirements of San Diego City Council Policy No. 100-17 regarding Drug-Free Workplace as outlined in the WHITEBOOK, Section 7-13.3, "Drug-Free Workplace", of the project specifications, and that;

This company_has in place a drug-free workplace program that complies with said policy. I further certify that each subcontract agreement for this project contains language which indicates the subcontractor's agreement to abide by the provisions of subdivisions a) through c) of the policy as outlined.

CONTRACTOR CERTIFICATION

AMERICAN WITH DISABILITIES ACT (ADA) COMPLIANCE CERTIFICATION

I hereby certify that I am familiar with the requirements of San Diego City Council Policy No. 100-4 regarding the American With Disabilities Act (ADA) outlined in the WHITEBOOK, Section 7-13.2, "American With Disabilities Act", of the project specifications, and that:

This company has in place workplace program that complies with said policy. I further certify that each subcontract agreement for this project contains language which indicates the subcontractor's agreement to abide by the provisions of the policy as outlined.

CONTRACTOR CERTIFICATION

CONTRACTOR STANDARDS – PLEDGE OF COMPLIANCE

I declare under penalty of perjury that I am authorized to make this certification on behalf of the company submitting this bid/proposal, that as Contractor, I am familiar with the requirements of City of San Diego Municipal Code § 22.3004 regarding Contractor Standards as outlined in the WHITEBOOK, Section 7-13.4, ("Contractor Standards"), of the project specifications, and that Contractor has complied with those requirements.

I further certify that each of the Contractor's subcontractors has completed a Pledge of Compliance attesting under penalty of perjury of having complied with City of San Diego Municipal Code § 22.3004.

CONTRACTOR CERTIFICATION

EQUAL BENEFITS ORDINANCE CERTIFICATION

I declare under penalty of perjury that I am familiar with the requirements of and in compliance with the City of San Diego Municipal Code § 22.4300 regarding Equal Benefits Ordinance.

CONTRACTOR CERTIFICATION

EQUAL PAY ORDINANCE CERTIFICATION

Contractor shall comply with the Equal Pay Ordinance (EPO) codified in the San Diego Municipal Code (SDMC) at section 22.4801 through 22.4809, unless compliance is not required based on an exception listed in SDMC section 22.4804.

Contractor shall require all of its subcontractors to certify compliance with the EPO in their written subcontracts.

Contractor must post a notice informing its employees of their rights under the EPO in the workplace or job site.

By signing this Contract with the City of San Diego, Contractor acknowledges the EPO requirements and pledges ongoing compliance with the requirements of SDMC Division 48, section 22.4801 et seq., throughout the duration of this Contract.

AFFIDAVIT OF DISPOSAL

(To be submitted upon completion of Construction pursuant to the contracts Certificate of Completion)

WHEREAS, on the _____ DAY OF _____, 2____ the undersigned entered into and executed a contract with the City of San Diego, a municipal corporation, for:

POINT LOMA OCEAN OUTFALL REPAIR

(Project Title)

as particularly described in said contract and identified as Bid No. **L-18-1710-DBB-1**; SAP No. (WBS/IO/CC) **21004004**; and **WHEREAS**, the specification of said contract requires the Contractor to affirm that "all brush, trash, debris, and surplus materials resulting from this project have been disposed of in a legal manner"; and **WHEREAS**, said contract has been completed and all surplus materials disposed of:

NOW, THEREFORE, in consideration of the final payment by the City of San Diego to said Contractor under the terms of said contract, the undersigned Contractor, does hereby affirm that all surplus materials as described in said contract have been disposed of at the following location(s)

and that they have been disposed of according to all applicable laws and regulations.

Dated this _____ DAY OF _____, _____.

By: _____
Contractor

ATTEST:

State of _____ County of _____

On this _____ DAY OF _____, 2____, before the undersigned, a Notary Public in and for said County and State, duly commissioned and sworn, personally appeared _____ known to me to be the _____ Contractor named in the foregoing Release, and whose name is subscribed thereto, and acknowledged to me that said Contractor executed the said Release.

Notary Public in and for said County and State

LIST OF SUBCONTRACTORS

***** PROVIDED FOR ILLUSTRATIVE PURPOSES ONLY *** TO BE SUBMITTED IN ELECTRONIC FORMAT ONLY *** SEE INSTRUCTIONS TO BIDDERS, FOR FURTHER INFORMATION**

In accordance with the requirements of the "Subletting and Subcontracting Fair Practices Act", Section 4100, of the California Public Contract Code (PCC), the Bidder is to list below the name, address and license number of each Subcontractor who will perform work, labor, render services or specially fabricate and install a portion [type] of the work or improvement, in an amount of or in excess of 0.5% of the Contractor's total Bid. Failure to comply with this requirement may result in the Bid being rejected as non-responsive. The Contractor is to list only one Subcontractor for each portion of the Work. The Bidder's attention is directed to the Special Provisions - General; Paragraph 2-3 Subcontracts, which stipulates the percentage of the Work to be performed with the Bidder's own forces. The Bidder is to also list all SLBE, ELBE, DBE, DVBE, MBE, WBE, OBE, SDB, WoSB, HUBZone, and SDVOSB Subcontractors for which the Bidders are seeking recognition towards achieving any mandatory, voluntary, or both subcontracting participation percentages.

| NAME, ADDRESS AND TELEPHONE NUMBER OF SUBCONTRACTOR | DIR Registration Number | CONSTRUCTOR OR DESIGNER | SUBCONTRACTOR LICENSE NUMBER | TYPE OF WORK | DOLLAR VALUE OF SUBCONTRACT | MBE, WBE, DBE, DVBE, OBE, ELBE, SLBE, SDB, WoSB, HUBZone, OR SDVOSB® | WHERE CERTIFIED ② | CHECK IF JOINT VENTURE PARTNERSHIP |
|--|-------------------------|-------------------------|------------------------------|--------------|-----------------------------|--|----------------------|------------------------------------|
| Name: _____ Address: _____ City: _____ State: _____ Zip: _____ Phone: _____ Email: _____ | | | | | | | | |
| Name: _____ Address: _____ City: _____ State: _____ Zip: _____ Phone: _____ Email: _____ | | | | | | | | |

- ① As appropriate, Bidder shall identify Subcontractor as one of the following and shall include a valid proof of certification (except for OBE, SLBE and ELBE):
- | | | | |
|---|--------|--|---------|
| Certified Minority Business Enterprise | MBE | Certified Woman Business Enterprise | WBE |
| Certified Disadvantaged Business Enterprise | DBE | Certified Disabled Veteran Business Enterprise | DVBE |
| Other Business Enterprise | OBE | Certified Emerging Local Business Enterprise | ELBE |
| Certified Small Local Business Enterprise | SLBE | Small Disadvantaged Business | SDB |
| Woman-Owned Small Business | WoSB | HUBZone Business | HUBZone |
| Service-Disabled Veteran Owned Small Business | SDVOSB | | |
- ② As appropriate, Bidder shall indicate if Subcontractor is certified by:
- | | | | |
|--|--------|--|----------|
| City of San Diego | CITY | State of California Department of Transportation | CALTRANS |
| California Public Utilities Commission | CPUC | | |
| State of California's Department of General Services | CADoGS | City of Los Angeles | LA |
| State of California | CA | U.S. Small Business Administration | SBA |

The Bidder will not receive any subcontracting participation percentages if the Bidder fails to submit the required proof of certification.

NAMED EQUIPMENT/MATERIAL SUPPLIER LIST

***** PROVIDED FOR ILLUSTRATIVE PURPOSES ONLY *** TO BE SUBMITTED IN ELECTRONIC FORMAT ONLY *** SEE INSTRUCTIONS TO BIDDERS FOR FURTHER INFORMATION**

| NAME, ADDRESS AND TELEPHONE NUMBER OF VENDOR/SUPPLIER | DIR Registration Number | MATERIALS OR SUPPLIES | DOLLAR VALUE OF MATERIAL OR SUPPLIES | SUPPLIER (Yes/No) | MANUFACTURER (Yes/No) | MBE, WBE, DBE, DVBE, OBE, ELBE, SLBE, SDB, WoSB, HUBZone, OR SDVOSB ^① | WHERE CERTIFIED ^② |
|--|-------------------------|-----------------------|--------------------------------------|-------------------|-----------------------|--|------------------------------|
| Name: _____ Address: _____ City: _____ State: _____ Zip: _____ Phone: _____ Email: _____ | | | | | | | |
| Name: _____ Address: _____ City: _____ State: _____ Zip: _____ Phone: _____ Email: _____ | | | | | | | |

- ① As appropriate, Bidder shall identify Vendor/Supplier as one of the following and shall include a valid proof of certification (except for OBE, SLBE and ELBE):
- | | | | |
|---|--------|--|---------|
| Certified Minority Business Enterprise | MBE | Certified Woman Business Enterprise | WBE |
| Certified Disadvantaged Business Enterprise | DBE | Certified Disabled Veteran Business Enterprise | DVBE |
| Other Business Enterprise | OBE | Certified Emerging Local Business Enterprise | ELBE |
| Certified Small Local Business Enterprise | SLBE | Small Disadvantaged Business | SDB |
| Woman-Owned Small Business | WoSB | HUBZone Business | HUBZone |
| Service-Disabled Veteran Owned Small Business | SDVOSB | | |
- ② As appropriate, Bidder shall indicate if Vendor/Supplier is certified by:
- | | | | |
|--|--------|--|----------|
| City of San Diego | CITY | State of California Department of Transportation | CALTRANS |
| California Public Utilities Commission | CPUC | | |
| State of California's Department of General Services | CADoGS | City of Los Angeles | LA |
| State of California | CA | U.S. Small Business Administration | SBA |

The Bidder will not receive any subcontracting participation percentages if the Bidder fails to submit the required proof of certification.

ELECTRONICALLY SUBMITTED FORMS

THE FOLLOWING FORMS MUST BE SUBMITTED IN PDF FORMAT WITH BID SUBMISSION

The following forms are to be completed by the bidder and submitted (uploaded) electronically with the bid in PlanetBids.

A. CONTRACTOR'S CERTIFICATION OF PENDING ACTIONS

Bids will not be accepted until ALL the above-named forms are submitted as part of the bid submittal

CONTRACTOR'S CERTIFICATION OF PENDING ACTIONS

As part of its bid or proposal (Non-Price Proposal in the case of Design-Build contracts), the Bidder shall provide to the City a list of all instances within the past 10 years where a complaint was filed or pending against the Bidder in a legal or administrative proceeding alleging that Bidder discriminated against its employees, subcontractors, vendors or suppliers, and a description of the status or resolution of that complaint, including any remedial action taken.

CHECK ONE BOX ONLY.

- The undersigned certifies that within the past 10 years the Bidder has NOT been the subject of a complaint or pending action in a legal administrative proceeding alleging that Bidder discriminated against its employees, subcontractors, vendors or suppliers.

- The undersigned certifies that within the past 10 years the Bidder has been the subject of a complaint or pending action in a legal administrative proceeding alleging that Bidder discriminated against its employees, subcontractors, vendors or suppliers. A description of the status or resolution of that complaint, including any remedial action taken and the applicable dates is as follows:

| DATE OF CLAIM | LOCATION | DESCRIPTION OF CLAIM | LITIGATION (Y/N) | STATUS | RESOLUTION/REMEDIAL ACTION TAKEN |
|---------------|----------|----------------------|------------------|--------|----------------------------------|
| N/A | N/A | N/A | N/A | N/A | N/A |
| | | | | | |
| | | | | | |
| | | | | | |
| | | | | | |
| | | | | | |

Contractor Name: De La Fuente Construction Inc.

Certified By Jorge Diaz De La Fuente Title CEO & President
 Name

 Signature Date 03/22/18

USE ADDITIONAL FORMS AS NECESSARY

Mandatory Disclosure of Business Interests Form

BIDDER/PROPOSER INFORMATION

De La Fuente Construction, Inc.

| | | | |
|---|--------------------|-------|--------------|
| Legal Name | DBA | | |
| 121 E 31st. Street Suite C. National City, CA 91950 | | | |
| Street Address | City | State | Zip |
| Jorge Diaz, President | 619.512.5505 ext#2 | | 619.878.2980 |
| Contact Person, Title | Phone | Fax | |

Provide the name, identity, and precise nature of the interest* of all persons who are directly or indirectly involved** in this proposed transaction (SDMC § 21.0103).

* The precise nature of the interest includes:

- the percentage ownership interest in a party to the transaction,
- the percentage ownership interest in any firm, corporation, or partnership that will receive funds from the transaction,
- the value of any financial interest in the transaction,
- any contingent interest in the transaction and the value of such interest should the contingency be satisfied, and
- any philanthropic, scientific, artistic, or property interest in the transaction.

** Directly or indirectly involved means pursuing the transaction by:

- communicating or negotiating with City officers or employees,
- submitting or preparing applications, bids, proposals or other documents for purposes of contracting with the City, or
- directing or supervising the actions of persons engaged in the above activity.

| | |
|---------------------------------|--|
| Jorge Enrique Diaz De La Fuente | President |
| Name | Title/Position |
| San Diego, CA | |
| City and State of Residence | Employer (if different than Bidder/Proposer) |
| General Contractor | |
| Interest in the transaction | |

| | |
|-----------------------------|--|
| Name | Title/Position |
| City and State of Residence | Employer (if different than Bidder/Proposer) |
| Interest in the transaction | |

| | |
|-----------------------------|--|
| Name | Title/Position |
| City and State of Residence | Employer (if different than Bidder/Proposer) |
| Interest in the transaction | |

| | |
|-----------------------------|--|
| Name | Title/Position |
| City and State of Residence | Employer (if different than Bidder/Proposer) |
| Interest in the transaction | |

| | |
|-----------------------------|--|
| Name | Title/Position |
| City and State of Residence | Employer (if different than Bidder/Proposer) |
| Interest in the transaction | |
| Name | Title/Position |
| City and State of Residence | Employer (if different than Bidder/Proposer) |
| Interest in the transaction | |
| Name | Title/Position |
| City and State of Residence | Employer (if different than Bidder/Proposer) |
| Interest in the transaction | |
| Name | Title/Position |
| City and State of Residence | Employer (if different than Bidder/Proposer) |
| Interest in the transaction | |
| Name | Title/Position |
| City and State of Residence | Employer (if different than Bidder/Proposer) |
| Interest in the transaction | |

*** Use Additional Pages if Necessary ***

Under penalty of perjury under the laws of the State of California, I certify that I am responsible for the completeness and accuracy of the responses contained herein, and that all information provided is true, full and complete to the best of my knowledge and belief. I agree to provide written notice to the Mayor or Designee within five (5) business days if, at any time, I learn that any portion of this Mandatory Disclosure of Business Interests Form requires an updated response. Failure to timely provide the Purchasing Agent with written notice is grounds for Contract termination.

| | | |
|---------------------------------|---|------------|
| Jorge Enrique Diaz De La Fuente |  | 04-20-2018 |
| Print Name, Title | Signature | Date |

Failure to sign and submit this form with the bid/proposal shall make the bid/proposal non-responsive. In the case of an informal solicitation, the contract will not be awarded unless a signed and completed Mandatory Disclosure of Business Interests Form is submitted.

City of San Diego

CITY CONTACT: Brittany Friedenreich, Contract Specialist, Email: BFriedenreic@sandiego.gov
Phone No. (619) 533-3104

ADDENDUM A



FOR

POINT LOMA OCEAN OUTFALL REPAIR

BID NO.: L-18-1710-DBB-1
SAP NO. (WBS/IO/CC): 21004004
CLIENT DEPARTMENT: 2012
COUNCIL DISTRICT: 2
PROJECT TYPE: BO

BID DUE DATE:

**1:30 PM
MARCH 22, 2018
CITY OF SAN DIEGO
PUBLIC WORKS CONTRACTS
525 B STREET, SUITE 750, MS 908A
SAN DIEGO, CA 92101**

A. CHANGES TO CONTRACT DOCUMENTS

The following changes to the Contract Documents are hereby made effective as though originally issued with the bid package. Bidders are reminded that all previous requirements to this solicitation remain in full force and effect.

B. CLARIFICATIONS

Per Section 21.1 of the Solicitation, for bids \$250,000 and above, bidders shall submit Bid Security at bid time.

C. CERTIFICATIONS AND FORMS

1. To Certifications and Forms, **ADD** Bid Bond page 3 of 3 of this Addendum.

James Nagelvoort, Director
Public Works Department

Dated: *March 19, 2018*
San Diego, California

JN/RWB/lji

BID BOND

**See Instructions to Bidders, Bidder Guarantee of Good Faith
(Bid Security)**

KNOW ALL MEN BY THESE PRESENTS,

That _____ as Principal, and _____ as Surety, are held and firmly bound unto The City of San Diego hereinafter called "OWNER," in the sum of **10% OF THE TOTAL BID AMOUNT** for the payment of which sum, well and truly to be made, we bind ourselves, our heirs, executors, administrators, successors, and assigns, jointly and severally, firmly by these presents.

WHEREAS, said Principal has submitted a Bid to said OWNER to perform the WORK required under the bidding schedule(s) of the OWNER's Contract Documents entitled

NOW THEREFORE, if said Principal is awarded a contract by said OWNER and, within the time and in the manner required in the "Notice Inviting Bids" enters into a written Agreement on the form of agreement bound with said Contract Documents, furnishes the required certificates of insurance, and furnishes the required Performance Bond and Payment Bond, then this obligation shall be null and void, otherwise it shall remain in full force and effect. In the event suit is brought upon this bond by said OWNER and OWNER prevails, said Surety shall pay all costs incurred by said OWNER in such suit, including a reasonable attorney's fee to be fixed by the court.

SIGNED AND SEALED, this _____ day of _____, 20_____

(Principal) (SEAL)

(Surety) (SEAL)

By: _____
(Signature)

By: _____
(Signature)

(SEAL AND NOTARIAL ACKNOWLEDGEMENT OF SURETY)

Bid Results

Bidder Details

Vendor Name De La Fuente Construction, Inc.
Address 121 E. 31st Street, Suite C
 National City, CA 91950
 United States
Respondee Joe Abueg
Respondee Title Senior Project Manager
Phone 619-517-4250 Ext.
Email joea@dlfci.com
Vendor Type LAT,MALE,ELBE,PQUAL,MBE,CADIR,SDB,Local
License # 919666
CADIR

Bid Detail

Bid Format Electronic
Submitted March 21, 2018 4:13:32 PM (Pacific)
Delivery Method
Bid Responsive
Bid Status Submitted
Confirmation # 134420
Ranking 0

Respondee Comment

Buyer Comment

Attachments

| File Title | File Name | File Type |
|---|---|---|
| Contractor Certification of Pending Actions | DLF Certification of Pending Actions Signed.pdf | Contractor's Certification of Pending Actions |
| In Lieu of Bid Bond | In Lieu of Bid Bond (Addendum A) Comments.pdf | Bid Bond |

Line Items

| Type | Item Code | UOM | Qty | Unit Price | Line Total | Comment |
|-----------------|---------------------------------|-----|-----|--------------|--------------|---------|
| Main Bid | | | | | | |
| 1 | Bonds (Payment and Performance) | | | | | |
| | 524126 | LS | 1 | \$4,669.00 | \$4,669.00 | |
| 2 | WPCP Development | | | | | |
| | 541330 | LS | 1 | \$1,000.00 | \$1,000.00 | |
| 3 | WPCP Implementation | | | | | |
| | 238990 | LS | 1 | \$3,500.00 | \$3,500.00 | |
| 4 | Outfall Repair | | | | | |
| | 238990 | LS | 1 | \$150,137.00 | \$150,137.00 | |
| 5 | Mobilization | | | | | |
| | 238990 | LS | 1 | \$7,471.00 | \$7,471.00 | |

Bid Results

| Type | Item Code | UOM | Qty | Unit Price | Line Total | Comment |
|-----------------|----------------------------|-----|-----|-------------|---------------------|---------|
| 6 | Field Orders (EOC Type II) | AL | 1 | \$20,000.00 | \$20,000.00 | |
| Subtotal | | | | | \$186,777.00 | |
| Total | | | | | \$186,777.00 | |

Subcontractors

| Name & Address | Description | License Num | CADIR | Amount | Type |
|--|-----------------------------------|-------------|------------|-------------|-----------------|
| C&W Diving Services Inc 1706 Hoover Ave National City , CA 91950 United States | Diving Services and related work. | A-389407 | 1000009794 | \$85,150.00 | Asian,MALE,DVBE |