

City of San Diego

ORIGINAL

CONTRACTOR'S NAME: Crest Equipment Inc.
ADDRESS: 161 Scottford Dr., El Cajon, CA 92021
TELEPHONE NO.: 619-444-5064 FAX NO.: _____
CITY CONTACT: Clementina Giordano, Contract Specialist, Email: Cgiordano@sanidiego.gov
Phone No. (619) 533-3481, Fax No. (619) 533-3633
S. Cochinwala / A. Rekani / LJI

BIDDING DOCUMENTS



FOR

Group Job 13I North Park DIF CR

BID NO.: L-17-1524-DBB-1
SAP NO. (WBS/IO/CC): B-13111
CLIENT DEPARTMENT: 1300
COUNCIL DISTRICT: 3
PROJECT TYPE: IJ, CA

THIS CONTRACT WILL BE SUBJECT TO THE FOLLOWING:

- COMPETITION RESTRICTED TO: SLBE-ELBE or ELBE FIRMS ONLY .
- PREVAILING WAGE RATES: STATE FEDERAL
- APPRENTICESHIP

BID DUE DATE:

**1:30 PM
NOVEMBER 22, 2016
CITY OF SAN DIEGO
PUBLIC WORKS CONTRACTS
1010 SECOND AVENUE, 14th FLOOR, MS 614C
SAN DIEGO, CA 92101**

ENGINEER OF WORK

The engineering Specifications and Special Provisions contained herein have been prepared by or under the direction of the following Registered Engineer:



For City Engineer

10/12/2016
Date

Seal

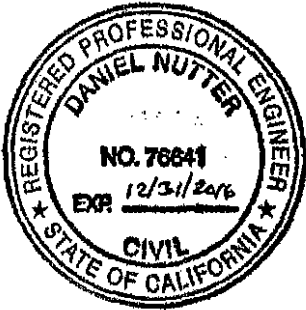

TABLE OF CONTENTS

SECTION	PAGE
1. NOTICE INVITING BIDS	4
2. INSTRUCTIONS TO BIDDERS	6
3. PERFORMANCE BOND, LABOR AND MATERIALMEN'S BONDS.....	16
4. ATTACHMENTS:	
A. SCOPE OF WORK.....	19
B. INTENTIONALLY LEFT BLANK.....	21
C. INTENTIONALLY LEFT BLANK.....	22
D. PREVAILING WAGES.....	23
E. SUPPLEMENTARY SPECIAL PROVISIONS	27
1. Appendix A - Notice of Exemption	44
2. Appendix B - Fire Hydrant Meter Program.....	47
3. Appendix C - Materials Typically Accepted by Certificate of Compliance.....	61
4. Appendix D - Sample City Invoice.....	63
5. Appendix E - Location Map.....	65
6. Appendix F - Adjacent Project.....	67
7. Appendix G - Sample of Public Notices.....	69
8. Appendix H - Advanced Metering Infrastructure (AMI) Device Protection.....	71
9. Appendix I - Private Property Permit	78
F. INTENTIONALLY LEFT BLANK.....	81
G. CONTRACT AGREEMENT	82
5. CERTIFICATIONS AND FORMS.....	85

NOTICE INVITING BIDS

1. **SUMMARY OF WORK:** This is the City of San Diego's (City) solicitation process to acquire Construction services for **Group Job 13I North Park DIF CR**. For additional information refer to Attachment A.
2. **LIMITED COMPETITION:** This contract may only be bid by the Contractors on the City's approved Prequalified Contractor's List **and** SLBE-ELBE Construction Limited Competition Contractors List in accordance with the designation stated on the cover page. For information regarding the SLBE-ELBE Construction Program and registration visit the City's web site: <http://www.sandiego.gov>.
3. **ESTIMATED CONSTRUCTION COST:** The City's estimated construction cost for this project is **\$165,000**.
4. **BID DUE DATE AND TIME ARE:** November 22, 2016 at 1:30 PM.
5. **PREVAILING WAGE RATES APPLY TO THIS CONTRACT:** Refer to Attachment D.
6. **LICENSE REQUIREMENT:** The City has determined that the following licensing classification(s) are required for this contract: **A**
7. **SUBCONTRACTING PARTICIPATION PERCENTAGES**
 - 7.1. The City has incorporated voluntary subcontractor participation percentage to enhance competition and maximize subcontracting opportunities as follows.
 - 7.2. The following voluntary subcontractor participation percentage for DBE, DVBE, WBE, MBE, SLBE, and ELBE certified Subcontractors shall apply to this contract:

Total voluntary subcontractor participation percentage for this project is 33.3%.
8. **PRE-BID MEETING:**
 - 8.1. Prospective Bidders are encouraged to attend the Pre-Bid Meeting. The purpose of the meeting is to discuss the scope of the Project, submittal requirements, the pre-qualification process and any Equal Opportunity Contracting Program requirements and reporting procedures. To request a sign language or oral interpreter for this visit, call the Public Works Contracts Division at (619) 533-3450 at least 5 Working Days prior to the meeting to ensure availability. The Pre-Bid meeting is scheduled as follows:

Date: November 2, 2016
Time 10:00 AM
Location: 1010 Second Avenue, Suite 1400, San Diego, CA 92101
(Large Conf. Rm)

Attendance at the Pre-Bid Meeting will be evidenced by the Bidder's representative's signature on the attendance roster. It is the responsibility of the Bidder's representative to complete and sign the attendance roster.

9. **AWARD PROCESS:**

- 9.1. The Award of this contract is contingent upon the Contractor's compliance with all conditions of Award as stated within these documents and within the Notice of Intent to Award.
- 9.2. Upon acceptance of a Bid, the City will prepare contract documents for execution within approximately 21 days of the date of the Bid opening. The City will then award the Contract within approximately 14 days of receipt of properly signed Contract, bonds, and insurance documents.
- 9.3. This contract will be deemed executed and effective only upon the signing of the Contract by the Mayor or his designee and approval as to form the City Attorney's Office.
- 9.4. The low Bid will be determined by Base Bid alone.
- 9.5. Once the low bid has been determined, the City may, at its sole discretion, award the contract for the Base bid alone.

10. **SUBMISSION OF QUESTIONS:**

- 10.1. The Public Works Department is responsible for opening, examining, and evaluating the competitive Bids submitted to the City for the acquisition, construction and completion of any public improvement except when otherwise set forth in these documents. All questions related to this solicitation shall be submitted to:

Public Works Contracts
1010 Second Avenue, 14th Floor
San Diego, California, 92101
Attention: Clementina Giordano

OR:

Clementina Giordano@sandiego.gov

- 10.2. Questions received less than 14 days prior to the date for opening of Bids may not be considered.
- 10.3. Questions or clarifications deemed by the City to be material shall be answered via issuance of an addendum and posted to the City's online bidding service.
- 10.4. Only questions answered by formal written addenda shall be binding. Oral and other interpretations or clarifications shall be without legal effect. It is the Bidder's responsibility to be informed of any addenda that have been issued and to include all such information in its Bid.

INSTRUCTIONS TO BIDDERS

1. PREQUALIFICATION OF CONTRACTORS:

- 1.1. Contractors submitting a Bid must be pre-qualified for the total amount proposed, including all alternate items, prior to the date of submittal. Bids from contractors who have not been pre-qualified as applicable and Bids that exceed the maximum dollar amount at which contractors are pre-qualified may be deemed **non-responsive** and ineligible for award. Complete information and links to the on-line prequalification application are available at:

<http://www.sandiego.gov/cip/bidopps/prequalification.shtml>

- 1.2. The completed application must be submitted online no later than 2 weeks prior to the bid opening. For additional information or the answer to questions about the prequalification program, contact David Stucky at 619-533-3474 or dstucky@sandiego.gov.
- 1.3. Due to the City's fiduciary requirement to safeguard vendor data, City staff will not be able to provide information regarding contractors' prequalification status over the telephone. Contractors may access real-time information about their prequalification status via their vendor profile on [PlanetBids™](#).

2. ELECTRONIC FORMAT RECEIPT AND OPENING OF BIDS: Bids will be received in electronic format (eBids) EXCLUSIVELY at the City of San Diego's electronic bidding (eBidding) site, at: <http://www.sandiego.gov/cip/bidopps/index.shtml> and are due by the date, and time shown on the cover of this solicitation.

- 2.1 BIDDERS MUST BE PRE-REGISTERED with the City's bidding system and possess a system-assigned Digital ID in order to submit an electronic bid.
- 2.2 The City's bidding system will automatically track information submitted to the site including IP addresses, browsers being used and the URLs from which information was submitted. In addition, the City's bidding system will keep a history of every login instance including the time of login, and other information about the user's computer configuration such as the operating system, browser type, version, and more. Because of these security features, Contractors who disable their browsers' cookies will not be able to log in and use the City's bidding system.
- 2.3 The City's electronic bidding system is responsible for bid tabulations. Upon the bidder's or proposer's entry of their bid, the system will ensure that all required fields are entered. **The system will not accept a bid for which any required information is missing.** This includes all necessary pricing, subcontractor listing(s) and any other essential documentation and supporting materials and forms requested or contained in these solicitation documents.

- 2.4 BIDS REMAIN SEALED UNTIL BID DEADLINE. eBids are transmitted into the City's bidding system via hypertext transfer protocol secure (https) mechanism using SSL 128-256 bit security certificates issued from Verisign/Thawte which encrypts data being transferred from client to server. Bids submitted prior to the "Bid Due Date and Time" are not available for review by anyone other than the submitter which has until the "Bid Due Date and Time" to change, rescind or retrieve its proposal should it desire to do so.
- 2.5 BIDS MUST BE SUBMITTED BY BID DUE DATE AND TIME. Once the bid deadline is reached, no further submissions are accepted into the system. Once the Bid Due Date and Time has lapsed, bidders, proposers, the general public, and City staff are able to immediately see the results on line. City staff may then begin reviewing the submissions for responsiveness, EOCP compliance and other issues. The City may require any Bidder to furnish statement of experience, financial responsibility, technical ability, equipment, and references.
- 2.6 RECAPITULATION OF THE WORK. Bids shall not contain any recapitulation of the Work. Conditional Bids may be rejected as being non-responsive. Alternative proposals will not be considered unless called for.
- 2.7 BIDS MAY BE WITHDRAWN by the Bidder only up to the bid due date and time.
- 2.7.1 Important Note:** Submission of the electronic bid into the system may not be instantaneous. Due to the speed and capabilities of the user's internet service provider (ISP), bandwidth, computer hardware and other variables, it may take time for the bidder's submission to upload and be received by the City's eBidding system. It is the bidder's sole responsibility to ensure their bids are received on time by the City's eBidding system. The City of San Diego is not responsible for bids that do not arrive by the required date and time.
- 2.8 ACCESSIBILITY AND AMERICANS WITH DISABILITIES ACT (ADA) COMPLIANCE. : To request a copy of this solicitation in an alternative format, contact the Public Works Contract Specialist listed in the cover of this solicitation at least five (5) working days prior to the Bid/Proposal due date to ensure availability.

3. ELECTRONIC BID SUBMISSIONS CARRY FULL FORCE AND EFFECT

- 3.1 The bidder, by submitting its electronic bid, acknowledges that doing so carries the same force and full legal effect as a paper submission with a longhand (wet) signature.
- 3.2 By submitting an electronic bid, the bidder certifies that the bidder has thoroughly examined and understands the entire Contract Documents (which consist of the plans and specifications, drawings, forms, affidavits and the solicitation documents), and that by submitting the eBid as its bid proposal, the

bidder acknowledges, agrees to and is bound by the entire Contract Documents, including any addenda issued thereto, and incorporated by reference in the Contract Documents.

3.3 The Bidder, by submitting its electronic bid, agrees to and certifies under penalty of perjury under the laws of the State of California, that the certification, forms and affidavits submitted as part of this bid are true and correct.

3.4 The Bidder agrees to the construction of the project as described in Attachment "A- Scope of Work" for the City of San Diego, in accordance with the requirements set forth herein for the electronically submitted prices. The Bidder guarantees the Contract Price for a period of 120 days (90 days for federally funded contracts and contracts valued at \$500,000 or less) from the date of Bid opening. The duration of the Contract Price guarantee shall be extended by the number of days required for the City to obtain all items necessary to fulfill all conditions precedent.

4. **BIDS ARE PUBLIC RECORDS:** Upon receipt by the City, Bids shall become public records subject to public disclosure. It is the responsibility of the respondent to clearly identify any confidential, proprietary, trade secret or otherwise legally privileged information contained within the Bid. General references to sections of the California Public Records Act (PRA) will not suffice. If the Contractor does not provide applicable case law that clearly establishes that the requested information is exempt from the disclosure requirements of the PRA, the City shall be free to release the information when required in accordance with the PRA, pursuant to any other applicable law, or by order of any court or government agency, and the Contractor will hold the City harmless for release of this information.

5. **CONTRACTOR REGISTRATION AND ELECTRONIC REPORTING SYSTEM:**

5.1 **Prior** to the Award of the Contract or Task Order, you and your Subcontractors and Suppliers must register with the City's web-based vendor registration and bid management system. For additional information go to:

<http://www.sandiego.gov/purchasing/bids-contracts/vendorreg.shtml>.

5.2 The City may not award the contract until registration of all subcontractors and suppliers is complete. In the event this requirement is not met within the time frame specified in the Notice of Intent to Award letter, the City reserves the right to rescind the Notice of Award / Intent to Award and to make the award to the next responsive and responsible bidder / proposer.

6. **JOINT VENTURE CONTRACTORS:** Provide a copy of the Joint Venture agreement and the Joint Venture license to the City within 10 Working Days after receiving the Contract forms. See 2-1.1.2, "Joint Venture Contractors" in The WHITEBOOK for details.

7. **PREVAILING WAGE RATES WILL APPLY:** Refer to Attachment D.

8. **SUBCONTRACTING PARTICIPATION PERCENTAGES:** Subcontracting participation percentages apply to this contract. Refer to Attachment E.

9. **INSURANCE REQUIREMENTS:**

9.1 All certificates of insurance and endorsements required by the contract are to be provided upon issuance of the City's Notice of Intent to Award letter.

9.2 Refer to sections 7-3, "LIABILITY INSURANCE", and 7-4, "WORKERS' COMPENSATION INSURANCE" of the Supplementary Special Provisions (SSP) for the insurance requirements which must be met.

10. **REFERENCE STANDARDS:** Except as otherwise noted or specified, the Work shall be completed in accordance with the following standards:

Title	Edition	Document
Standard Specifications for Public Works Construction ("The GREENBOOK") http://www.greenbookspecs.org/	2015	PWPI07011-01
City of San Diego Standard Specifications for Public Works Construction ("The WHITEBOOK")* http://www.sandiego.gov/publicworks/edocref/greenbook.shtml	2015	PWPI07011-02
City of San Diego Standard Drawings* http://www.sandiego.gov/publicworks/edocref/standarddraw/	2016	PWPI07011-03
Citywide Computer Aided Design and Drafting (CADD) Standards https://www.sandiego.gov/publicworks/edocref/drawings	2016	PWPI092816-04
California Department of Transportation (CALTRANS) Standard Specifications - http://www.dot.ca.gov/des/oe/construction-contract-standards.html	2015	PWPI092816-05
CALTRANS Standard Plans - http://www.dot.ca.gov/des/oe/construction-contract-standards.html	2015	PWPI092816-06
California Manual on Uniform Traffic Control Devices Revision 1 (CA MUTCD Rev 1) - http://www.dot.ca.gov/trafficops/camutcd/	2014	PWPI092816-07
NOTE: *Available online under Engineering Documents and References at: http://www.sandiego.gov/publicworks/edocref/index.shtml		

11. **CITY'S RESPONSES AND ADDENDA:** The City, at its discretion, may respond to any or all questions submitted in writing via the City's eBidding web site in the **form of an addendum**. No other responses to questions, oral or written shall be of any force or effect with respect to this solicitation. The changes to the Contract Documents through addenda are made effective as though originally issued with the Bid. The Bidders shall acknowledge the receipt of Addenda at the time of bid submission.

12. CITY'S RIGHTS RESERVED: The City reserves the right to cancel the Notice Inviting Bids at any time, and further reserves the right to reject submitted Bids, without giving any reason for such action, at its sole discretion and without liability. Costs incurred by the Bidder(s) as a result of preparing Bids under the Notice Inviting Bids shall be the sole responsibility of each bidder. The Notice Inviting Bids creates or imposes no obligation upon the City to enter a contract.

13. CONTRACT PRICING: This solicitation is for a Lump Sum contract with Unit Price provisions as set forth herein. The Bidder agrees to perform construction services for the City of San Diego in accordance with these contract documents for the prices listed below. The Bidder further agrees to guarantee the Contract Price for a period of 120 days from the date of Bid opening. The duration of the Contract Price guarantee may be extended, by mutual consent of the parties, by the number of days required for the City to obtain all items necessary to fulfill all contractual conditions.

14. SUBCONTRACTOR INFORMATION:

14.1 LISTING OF SUBCONTRACTORS. In accordance with the requirements provided in the "Subletting and Subcontracting Fair Practices Act" of the California Public Contract Code, the Bidder shall provide the **NAME** and **ADDRESS** of each Subcontractor who will perform work, labor, render services or who specially fabricates and installs a portion [type] of the work or improvement, in an amount in excess of 0.5% of the Contractor's total Bid. The Bidder shall also state within the description, whether the subcontractor is a **CONSTRUCTOR, CONSULTANT** or **SUPPLIER**. The Bidder shall further state within the description, the **PORTION** of the work which will be performed by each subcontractor under this Contract. The Contractor shall list only one Subcontractor for each portion of the Work. The **DOLLAR VALUE** of the total Bid to be performed shall be stated for all subcontractors listed. Failure to comply with this requirement may result in the Bid being rejected as **non-responsive** and ineligible for award. The Bidder's attention is directed to the Special Provisions - General; Paragraph 2-3 Subcontracts, which stipulates the percent of the Work to be performed with the Bidders' own forces. The Bidder shall list all SLBE, ELBE, DBE, DVBE, MBE, WBE, OBE, SDB, WoSB, HUBZone, and SDVOSB Subcontractors for which Bidders are seeking recognition towards achieving any mandatory, voluntary (or both) subcontracting participation goals.

14.2 LISTING OF SUPPLIERS. Any Bidder seeking the recognition of Suppliers of equipment, materials, or supplies obtained from third party Suppliers towards achieving any mandatory or voluntary (or both) subcontracting participation goals shall provide, at a minimum, the **NAME, LOCATION (CITY)** and the **DOLLAR VALUE** of each supplier. The Bidder will be credited up to 60% of the amount to be paid to the Suppliers for materials and supplies unless vendor manufactures or substantially alters materials and supplies, in which case, 100% will be credited. The Bidder is to indicate within the description whether the listed firm is a supplier

or manufacturer. If no indication is provided, the listed firm will be credited at 60% of the listed dollar value for purposes of calculating the Subcontractor Participation Percentage.

- 14.3 **LISTING OF SUBCONTRACTORS OR SUPPLIERS FOR ALTERNATES.** For subcontractors or suppliers to be used on additive or deductive alternate items, in addition to the above requirements, bidder shall further note "ALTERNATE" and alternate item number within the description.
15. **SUBMITTAL OF "OR EQUAL" ITEMS:** See Section 4-1.6, "Trade Names or Equals" in The WHITEBOOK and as amended in the SSP.
16. **AWARD PROCESS:**
- 16.1 The Award of this contract is contingent upon the Contractor's compliance with all conditions precedent to Award.
- 16.2 Upon acceptance of a Bid, the City will prepare contract documents for execution within approximately 21 days of the date of the Bid opening and award the Contract approximately within 7 days of receipt of properly executed Contract, bonds, and insurance documents.
- 16.3 This contract will be deemed executed and effective only upon the signing of the Contract by the Mayor or his designee and approval as to form the City Attorney's Office.
17. **SUBCONTRACT LIMITATIONS:** The Bidder's attention is directed to Standard Specifications for Public Works Construction, Section 2-3, "SUBCONTRACTS" in The GREENBOOK and as amended in the SSP which requires the Contractor to self-perform not less than the specified amount. Failure to comply with this requirement shall render the bid **non-responsive** and ineligible for award.
18. **AVAILABILITY OF PLANS AND SPECIFICATIONS:** Contract Documents may be obtained by visiting the City's website: <http://www.sandiego.gov/cip/>. Plans and Specifications for this contract are also available for review in the office of the City Clerk or Public Works Contracts.
19. **ONLY ONE BID PER CONTRACTOR SHALL BE ACCEPTED:** No person, firm, or corporation shall be allowed to make, file, or be interested in more than one (1) Bid for the same work unless alternate Bids are called for. A person, firm or corporation who has submitted a sub-proposal to a Bidder, or who has quoted prices on materials to a Bidder, is not hereby disqualified from submitting a sub-proposal or quoting prices to other Bidders or from submitting a Bid in its own behalf. Any Bidder who submits more than one bid will result in the rejection of all bids submitted.
20. **SAN DIEGO BUSINESS TAX CERTIFICATE:** The Contractor and Subcontractors, not already having a City of San Diego Business Tax Certificate for the work contemplated shall secure

the appropriate certificate from the City Treasurer, Civic Center Plaza, first floor and submit to the Contract Specialist upon request or as specified in the Contract Documents. Tax Identification numbers for both the Bidder and the listed Subcontractors must be submitted on the City provided forms within these documents.

21. BIDDER'S GUARANTEE OF GOOD FAITH (BID SECURITY):

- 21.1 For bids \$250,000 and above, bidders shall submit Bid Security at bid time. Bid Security shall be in one of the following forms: a cashier's check, or a properly certified check upon some responsible bank; or an approved corporate surety bond payable to the City of San Diego for an amount of not less than 10% of the total bid amount.
- 21.2 This check or bond, and the monies represented thereby, will be held by the City as a guarantee that the Bidder, if awarded the contract, will in good faith enter into the contract and furnish the required final performance and payment bonds.
- 21.3 The Bidder agrees that in the event of the Bidder's failure to execute this contract and provide the required final bonds, the money represented by the cashier's or certified check will remain the property of the City; and the Surety agrees that it will pay to the City the damages, not exceeding the sum of 10% of the amount of the Bid, that the City may suffer as a result of such failure.
- 21.4 At the time of bid submission, bidders must upload and submit an electronic PDF copy of the aforementioned bid security. Whether in the form of a cashier's check, a properly certified check or an approved corporate surety bond payable to the City of San Diego, the bid security must be uploaded to the City's eBidding system. Within twenty-four (24) hours after the bid due date and time, the first five (5) apparent low bidders must provide the City with the original bid security.
- 21.5 Failure to submit the electronic version of the bid security at the time of bid submission AND failure to provide the original within twenty-four (24) hours may cause the bid to be rejected and deemed **non-responsive**.

22. AWARD OF CONTRACT OR REJECTION OF BIDS:

- 22.1 This contract may be awarded to the lowest responsible and reliable Bidder.
- 22.2 Bidders shall complete ALL eBid forms as required by this solicitation. Incomplete eBids will not be accepted.
- 22.3 The City reserves the right to reject any or all Bids, to waive any informality or technicality in Bids received, and to waive any requirements of these specifications as to bidding procedure.
- 22.4 Bidders will not be released on account of their errors of judgment. Bidders may be released only upon receipt by the City within 3 Working Days of the bid opening, written notice from the Bidder which shows proof of honest, credible, clerical error of

a material nature, free from fraud or fraudulent intent; and of evidence that reasonable care was observed in the preparation of the Bid.

- 22.5 A bidder who is not selected for contract award may protest the award of a contract to another bidder by submitting a written protest in accordance with the San Diego Municipal Code.
- 22.6 The City of San Diego will not discriminate in the award of contracts with regard to race, religion creed, color, national origin, ancestry, physical handicap, marital status, sex or age.
- 22.7 Each Bid package properly signed as required by these specifications shall constitute a firm offer which may be accepted by the City within the time specified herein.
- 22.8 The City reserves the right to evaluate all Bids and determine the lowest Bidder on the basis of the base bid and any proposed alternates or options as detailed herein.

23. BID RESULTS:

- 23.1 The availability of the bids on the City's eBidding system shall constitute the public announcement of the apparent low bidder. In the event that the apparent low bidder is subsequently deemed non-responsive or non-responsible, a notation of such will be made on the eBidding system. The new ranking and apparent low bidder will be adjusted accordingly.
- 23.2 To obtain the bid results, view the results on the City's web site, or request the results by U.S. mail and provide a self-addressed, stamped envelope. If requesting by mail, be sure to reference the bid name and number. The bid tabulations will be mailed to you upon their completion. The results will not be given over the telephone.

24. THE CONTRACT:

- 24.1 The Bidder to whom award is made shall execute a written contract with the City of San Diego and furnish good and approved bonds and insurance certificates specified by the City within 14 days after receipt by Bidder of a form of contract for execution unless an extension of time is granted to the Bidder in writing.
- 24.2 If the Bidder takes longer than 14 days to fulfill these requirements, then the additional time taken shall be added to the Bid guarantee. The Contract shall be made in the form adopted by the City, which includes the provision that no claim or suit whatsoever shall be made or brought by Contractor against any officer, agent, or employee of the City for or on account of anything done or omitted to be done in connection with this contract, nor shall any such officer, agent, or employee be liable hereunder.
- 24.3 If the Bidder to whom the award is made fails to enter into the contract as herein provided, the award may be annulled and the Bidder's Guarantee of Good Faith will

be subject to forfeiture. An award may be made to the next lowest responsible and reliable Bidder who shall fulfill every stipulation embraced herein as if it were the party to whom the first award was made.

24.4 Pursuant to the San Diego City Charter section 94, the City may only award a public works contract to the lowest responsible and reliable Bidder. The City will require the Apparent Low Bidder to (i) submit information to determine the Bidder's responsibility and reliability, (ii) execute the Contract in form provided by the City, and (iii) furnish good and approved bonds and insurance certificates specified by the City within 14 Days, unless otherwise approved by the City, in writing after the Bidder receives notification from the City, designating the Bidder as the Apparent Low Bidder and formally requesting the above mentioned items.

24.5 The award of the Contract is contingent upon the satisfactory completion of the above mentioned items and becomes effective upon the signing of the Contract by the Mayor or designee and approval as to form the City Attorney's Office. If the Apparent Low Bidder does not execute the Contract or submit required documents and information, the City may award the Contract to the next lowest responsible and reliable Bidder who shall fulfill every condition precedent to award. A corporation designated as the Apparent Low Bidder shall furnish evidence of its corporate existence and evidence that the officer signing the Contract and bond for the corporation is duly authorized to do so.

25. EXAMINATION OF PLANS, SPECIFICATIONS, AND SITE OF WORK: The Bidder shall examine carefully the Project Site, the Plans and Specifications, other materials as described in the Special Provisions, Section 2-7, and the proposal forms (e.g., Bidding Documents). The submission of a Bid shall be conclusive evidence that the Bidder has investigated and is satisfied as to the conditions to be encountered, as to the character, quality, and scope of Work, the quantities of materials to be furnished, and as to the requirements of the Bidding Documents Proposal, Plans, and Specifications.

26. CITY STANDARD PROVISIONS: This contract is subject to the following standard provisions. See The WHITEBOOK for details.

26.1 The City of San Diego Resolution No. R-277952 adopted on May 20, 1991 for a Drug-Free Workplace.

26.2 The City of San Diego Resolution No. R-282153 adopted on June 14, 1993 related to the Americans with Disabilities Act.

26.3 The City of San Diego Municipal Code §22.3004 for Pledge of Compliance.

26.4 The City of San Diego's Labor Compliance Program and the State of California Labor Code §§1771.5(b) and 1776.

- 26.5 Sections 1777.5, 1777.6, and 1777.7 of the State of California Labor Code concerning the employment of apprentices by contractors and subcontractors performing public works contracts.
- 26.6 The City's Equal Benefits Ordinance (EBO), Chapter 2, Article 2, Division 43 of The San Diego Municipal Code (SDMC).
- 26.7 The City's Information Security Policy (ISP) as defined in the City's Administrative Regulation 90.63.

27. PRE-AWARD ACTIVITIES:

- 27.1 The contractor selected by the City to execute a contract for this Work shall submit the required documentation as specified in the herein and in the Notice of Award. Failure to provide the information as specified may result in the Bid being rejected as **non-responsive**.
- 27.2 The decision that bid is non-responsive for failure to provide the information required within the time specified shall be at the sole discretion of the City.

Issued in Triplicate

Premium will be adjusted
based on final contract price

Bond No.: 5225282
Premium: \$2,879.00

PERFORMANCE BOND, LABOR AND MATERIALMEN'S BOND

FAITHFUL PERFORMANCE BOND AND LABOR AND MATERIALMEN'S BOND:

Crest Equipment Inc., a corporation, as principal, and
SureTec Insurance Company, a corporation authorized to do
business in the State of California, as Surety, hereby obligate themselves, their successors and
assigns, jointly and severally, to The City of San Diego a municipal corporation in the sum of
One Hundred Twenty-Five Thousand Two Hundred Thirty-Five Dollars (\$125,235.00) for the
faithful performance of the annexed contract, and in the sum of One Hundred Twenty-Five
Thousand Two Hundred Thirty-Five Dollars (\$125,235.00) for the benefit of laborers and
materialmen designated below.

Conditions:

If the Principal shall faithfully perform the annexed contract with the City of San Diego,
California, then the obligation herein with respect to a faithful performance shall be void; otherwise
it shall remain in full force.

If the Principal shall promptly pay all persons, firms and corporations furnishing materials
for or performing labor in the execution of this contract, and shall pay all amounts due under the
California Unemployment Insurance Act then the obligation herein with respect to laborers and
materialmen shall be void; otherwise it shall remain in full force.

The obligation herein with respect to laborers and materialmen shall inure to the benefit of
all persons, firms and corporations entitled to file claims under the provisions of Article 2. Claimants,
(iii) public works of improvement commencing with Civil Code Section 9100 of the Civil Code of the
State of California.

Changes in the terms of the annexed contract or specifications accompanying same or
referred to therein shall not affect the Surety's obligation on this bond, and the Surety hereby waives
notice of same.

PERFORMANCE BOND, LABOR AND MATERIALMEN'S BOND (continued)

The Surety shall pay reasonable attorney's fees should suit be brought to enforce the provisions of this bond.

Dated December 2, 2016

Approved as to Form

Crest Equipment Inc.

Principal
By Wendy Belo

Wendy Belo

Printed Name of Person Signing for Principal

Mara W. Elliot, City Attorney

By [Signature]
Deputy City Attorney

SureTec Insurance Company

Surety
By [Signature]
Cyndi Beilman
Attorney-in-fact

Approved:

3033 5th Avenue #300

Local Address of Surety

By [Signature]

San Diego, CA 92103

Local Address (City, State) of Surety

Clementina Giordano, Contract Specialist
Public Works Contracting

619-400-4100

Local Telephone No. of Surety

Premium \$ 2,879.00

Bond No. 5225282

CALIFORNIA ALL-PURPOSE ACKNOWLEDGMENT

A notary public or other officer completing this certificate verifies only the identity of the individual who signed the document to which this certificate is attached, and not the truthfulness, accuracy, or validity of that document.

STATE OF CALIFORNIA

County of San Diego

On December 2, 2016 before me, Dana L. Michaelis, Notary Public,
Date Insert Name of Notary exactly as it appears on the official seal

personally appeared Cyndi Beilman

Name(s) of Signer(s)



Place Notary Seal Above

who proved to me on the basis of satisfactory evidence to be the person(s) whose name(s) is/are subscribed to the within instrument and acknowledged to me that he/she/they executed the same in his/her/their authorized capacity(ies), and that by his/her/their signature(s) on the instrument the person(s), or the entity upon behalf of which the person(s) acted, executed the instrument.

I certify under PENALTY OF PERJURY under the laws of the State of California that the foregoing paragraph is true and correct.

Witness my hand and official seal.

Signature Dana L. Michaelis
Signature of Notary Public Dana L. Michaelis

OPTIONAL

Though the information below is not required by law, it may prove valuable to persons relying on the document and could prevent fraudulent removal and reattachment of the form to another document.

Description of Attached Document

Title or Type of Document: _____

Document Date: _____ Number of Pages: _____

Signer(s) Other Than Named Above: _____

Capacity(ies) Claimed by Signer(s)

Signer's Name: _____

- Individual
- Corporate Officer — Title(s): _____
- Partner Limited General
- Attorney in Fact
- Trustee
- Guardian or Conservator
- Other: _____

RIGHT THUMBPRINT
OF SIGNER

Top of thumb here

Signer is Representing: _____

Signer's Name: _____

- Individual
- Corporate Officer — Title(s): _____
- Partner Limited General
- Attorney in Fact
- Trustee
- Guardian or Conservator
- Other: _____

RIGHT THUMBPRINT
OF SIGNER

Top of thumb here

Signer is Representing: _____

SureTec Insurance Company

LIMITED POWER OF ATTORNEY

Know All Men by These Presents, That SURETEC INSURANCE COMPANY (the "Company"), a corporation duly organized and existing under the laws of the State of Texas, and having its principal office in Houston, Harris County, Texas, does by these presents make, constitute and appoint

Anne Wright, Cyndi Bellman, Dana Michaelis

its true and lawful Attorney-in-fact, with full power and authority hereby conferred in its name, place and stead, to execute, acknowledge and deliver any and all bonds, recognizances, undertakings or other instruments or contracts of suretyship to include waivers to the conditions of contracts and consents of surety for:

Five Million and 00/100 Dollars (\$5,000,000.00)

and to bind the Company thereby as fully and to the same extent as if such bond were signed by the President, sealed with the corporate seal of the Company and duly attested by its Secretary, hereby ratifying and confirming all that the said Attorney-in-Fact may do in the premises. Said appointment shall continue in force until 05/18/2017 and is made under and by authority of the following resolutions of the Board of Directors of the SureTec Insurance Company:

Be it Resolved, that the President, any Vice-President, any Assistant Vice-President, any Secretary or any Assistant Secretary shall be and is hereby vested with full power and authority to appoint any one or more suitable persons as Attorney(s)-in-Fact to represent and act for and on behalf of the Company subject to the following provisions:

Attorney-in-Fact may be given full power and authority for and in the name of and of behalf of the Company, to execute, acknowledge and deliver, any and all bonds, recognizances, contracts, agreements or indemnity and other conditional or obligatory undertakings and any and all notices and documents canceling or terminating the Company's liability thereunder, and any such instruments so executed by any such Attorney-in-Fact shall be binding upon the Company as if signed by the President and sealed and effected by the Corporate Secretary.

Be it Resolved, that the signature of any authorized officer and seal of the Company heretofore or hereafter affixed to any power of attorney or any certificate relating thereto by facsimile, and any power of attorney or certificate bearing facsimile signature or facsimile seal shall be valid and binding upon the Company with respect to any bond or undertaking to which it is attached. *(Adopted at a meeting held on 20th of April, 1999.)*

In Witness Whereof, SURETEC INSURANCE COMPANY has caused these presents to be signed by its President, and its corporate seal to be hereto affixed this 21st day of March, A.D. 2013.

SURETEC INSURANCE COMPANY

By: [Signature]
John Knox Jr., President



State of Texas ss:
County of Harris

On this 21st day of March, A.D. 2013 before me personally came John Knox Jr., to me known, who, being by me duly sworn, did depose and say, that he resides in Houston, Texas, that he is President of SURETEC INSURANCE COMPANY, the company described in and which executed the above instrument; that he knows the seal of said Company; that the seal affixed to said instrument is such corporate seal; that it was so affixed by order of the Board of Directors of said Company; and that he signed his name thereto by like order.

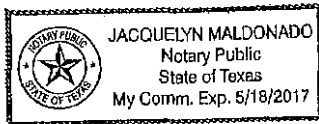

[Signature]
Jacquelyn Maldonado, Notary Public
My commission expires May 18, 2017

I, M. Brent Beaty, Assistant Secretary of SURETEC INSURANCE COMPANY, do hereby certify that the above and foregoing is a true and correct copy of a Power of Attorney, executed by said Company, which is still in full force and effect; and furthermore, the resolutions of the Board of Directors, set out in the Power of Attorney are in full force and effect.

Given under my hand and the seal of said Company at Houston, Texas this 6th day of Decemeber, 2016, A.D.

[Signature]
M. Brent Beaty, Assistant Secretary

Any instrument issued in excess of the penalty stated above is totally void and without any validity.
For verification of the authority of this power you may call (713) 812-0800 any business day between 8:00 am and 5:00 pm CST.

ATTACHMENTS

ATTACHMENT A
SCOPE OF WORK

SCOPE OF WORK

1. **SCOPE OF WORK:** Group Job 13I North Park will relocate the storm drain and install accessible curb ramps at the following intersections: University Avenue and Crestwood Place; 30th and Laurel Streets, 32nd and Thorn Streets. The work on University Avenue and Crestwood Place shall be completed as the first order of work.
 - 1.1. The Work shall be performed in accordance with:
 - 1.1.1. The Notice Inviting Bids and Plans numbered **38156-01-D** through **38156-05-D**, inclusive.
2. **ESTIMATED CONSTRUCTION COST:** The City's estimated construction cost for this project is **\$165,000**.
3. **LOCATION OF WORK: The location of the Work is as follows:** University Avenue and Crestwood Place, Laurel Street and 30th Street, and 32nd Street and Thorn Street. See location map in **Appendix E**.
4. **CONTRACT TIME:** The Contract Time for completion of the Work shall be **66 Working Days**.
 - 4.1. **CONTRACTOR'S LICENSE CLASSIFICATION:** In accordance with the provisions of California Law, the Contractor shall possess valid, appropriate license(s) at the time that the Bid is submitted. Failure to possess the specified license(s) may render the Bid as **non-responsive** and ineligible for award.
 - 4.2. The City has determined that the following licensing classification(s) are required for this contract:
 - CLASS A

ATTACHMENT B
INTENTIONALLY LEFT BLANK

ATTACHMENT C
INTENTIONALLY LEFT BLANK

ATTACHMENT D
PREVAILING WAGES

ATTACHMENT D
PREVAILING WAGES

1. **PREVAILING WAGE RATES:** Pursuant to San Diego Municipal Code section 22.3019, construction, alteration, demolition, repair and maintenance work performed under this Contract is subject to State prevailing wage laws. For construction work performed under this Contract cumulatively exceeding \$25,000 and for alteration, demolition, repair and maintenance work performed under this Contract cumulatively exceeding \$15,000, the Contractor and its subcontractors shall comply with State prevailing wage laws including, but not limited to, the requirements listed below.
 - 1.1. **Compliance with Prevailing Wage Requirements.** Pursuant to sections 1720 through 1861 of the California Labor Code, the Contractor and its subcontractors shall ensure that all workers who perform work under this Contract are paid not less than the prevailing rate of per diem wages as determined by the Director of the California Department of Industrial Relations (DIR). This includes work performed during the design and preconstruction phases of construction including, but not limited to, inspection and land surveying work.
 - 1.1.1. Copies of such prevailing rate of per diem wages are on file at the City and are available for inspection to any interested party on request. Copies of the prevailing rate of per diem wages also may be found at <http://www.dir.ca.gov/OPRL/DPreWageDetermination.htm>. Contractor and its subcontractors shall post a copy of the prevailing rate of per diem wages determination at each job site and shall make them available to any interested party upon request.
 - 1.1.2. The wage rates determined by the DIR refer to expiration dates. If the published wage rate does not refer to a predetermined wage rate to be paid after the expiration date, then the published rate of wage shall be in effect for the life of this Contract. If the published wage rate refers to a predetermined wage rate to become effective upon expiration of the published wage rate and the predetermined wage rate is on file with the DIR, such predetermined wage rate shall become effective on the date following the expiration date and shall apply to this Contract in the same manner as if it had been published in said publication. If the predetermined wage rate refers to one or more additional expiration dates with additional predetermined wage rates, which expiration dates occur during the life of this Contract, each successive predetermined wage rate shall apply to this Contract on the date following the expiration date of the previous wage rate. If the last of such predetermined wage rates expires during the life of this Contract, such wage rate shall apply to the balance of the Contract.
 - 1.2. **Penalties for Violations.** Contractor and its subcontractors shall comply with California Labor Code section 1775 in the event a worker is paid less than the prevailing wage rate for the work or craft in which the worker is employed.

- 1.3. Payroll Records.** Contractor and its subcontractors shall comply with California Labor Code section 1776, which generally requires keeping accurate payroll records, verifying and certifying payroll records, and making them available for inspection. Contractor shall require its subcontractors to also comply with section 1776. Contractor and its subcontractors shall submit weekly certified payroll records online via the City's web-based Labor Compliance Program. Contractor is responsible for ensuring its subcontractors submit certified payroll records to the City.
- 1.3.1.** For contracts entered into on or after April 1, 2015, Contractor and their subcontractors shall furnish records specified in Labor Code section 1776 directly to the Labor Commissioner in the manner required by Labor Code section 1771.4.
- 1.4. Apprentices.** Contractor and its subcontractors shall comply with California Labor Code sections 1777.5, 1777.6 and 1777.7 concerning the employment and wages of apprentices. Contractor is held responsible for the compliance of their subcontractors with sections 1777.5, 1777.6 and 1777.7.
- 1.5. Working Hours.** Contractor and their subcontractors shall comply with California Labor Code sections 1810 through 1815, including but not limited to: (i) restrict working hours on public works contracts to eight hours a day and forty hours a week, unless all hours worked in excess of 8 hours per day are compensated at not less than 1½ times the basic rate of pay; and (ii) specify penalties to be imposed on design professionals and subcontractors of \$25 per worker per day for each day the worker works more than 8 hours per day and 40 hours per week in violation of California Labor Code sections 1810 through 1815.
- 1.6. Required Provisions for Subcontracts.** Contractor shall include at a minimum a copy of the following provisions in any contract they enter into with a subcontractor: California Labor Code sections 1771, 1771.1, 1775, 1776, 1777.5, 1810, 1813, 1815, 1860 and 1861.
- 1.7. Labor Code Section 1861 Certification.** Contractor in accordance with California Labor Code section 3700 is required to secure the payment of compensation of its employees and by signing this Contract, Contractor certifies that "I am aware of the provisions of Section 3700 of the California Labor Code which require every employer to be insured against liability for workers' compensation or to undertake self-insurance in accordance with the provisions of that code, and I will comply with such provisions before commencing the performance of the work of this Contract."
- 1.8. Labor Compliance Program.** The City has its own Labor Compliance Program authorized in August 2011 by the DIR. The City will withhold contract payments when payroll records are delinquent or deemed inadequate by the City or other governmental entity, or it has been established after an investigation by the City or other governmental entity that underpayment(s) have occurred. For questions

or assistance, please contact the City of San Diego's Equal Opportunity Contracting Department at 619-236-6000.

1.9. Contractor and Subcontractor Registration Requirements. This project is subject to compliance monitoring and enforcement by the DIR. As of March 1, 2015, no contractor or subcontractor may be listed on a bid or proposal for a public works project unless registered with the DIR pursuant to Labor Code section 1725.5. As of April 1, 2015, a contractor or subcontractor shall not be qualified to bid on, be listed in a bid proposal, or enter into any contract for public work, unless currently registered and qualified to perform public work pursuant to Labor Code section 1725.5. By submitting a bid or proposal to the City, Contractor is certifying that he or she has verified that all subcontractors used on this public work project are registered with the DIR in compliance with Labor Code sections 1771.1 and 1725.5, and Contractor shall provide proof of registration to the City upon request.

1.9.1. A Contractor's inadvertent error in listing a subcontractor who is not registered pursuant to Labor Code section 1725.5 in response to a solicitation shall not be grounds for filing a bid protest or grounds for considering the bid non-responsive provided that any of the following apply: (1) the subcontractor is registered prior to bid opening; (2) within twenty-four hours after the bid opening, the subcontractor is registered and has paid the penalty registration fee specified in Labor Code section 1725.5; or (3) the subcontractor is replaced by another registered subcontractor pursuant to Public Contract Code section 4107.

ATTACHMENT E
SUPPLEMENTARY SPECIAL PROVISIONS

SUPPLEMENTARY SPECIAL PROVISIONS

The following Supplementary Special Provisions (SSP) modifies the following documents:

1. The **2015 Edition** of the Standard Specifications for Public Works Construction (The "GREENBOOK") currently in effect.
2. The **2015 Edition** of the City of San Diego Standard Specifications for Public Works Construction (The "WHITEBOOK"), addressed as the "City Supplement" herein, including the following:
 - a. General Provisions (A) for all Contracts.

SECTION 1 – TERMS, DEFINITIONS, ABBREVIATIONS, UNITS OF MEASURE, AND SYMBOLS

- 1-2 TERMS AND DEFINITIONS.** To the City Supplement, item 54, "Normal Working Hours", ADD the following:

The **Normal Working Hours** are **7:30 AM** to **3:30 PM**.

SECTION 2 - SCOPE AND CONTROL OF WORK

- 2-3.2 Self Performance.** DELETE in its entirety and SUBSTITUTE with the following:

1. You shall perform, with your own organization, Contract Work amounting to at least 50% of the base Bid **AND** 50% of any alternates.

- 2-14.3 Coordination.** To the City Supplement, ADD the following:

2. Other adjacent City projects are scheduled for construction for the same time period in the vicinity of University Avenue and Crestwood Place. See Appendix "F" for the approximate location. Coordinate the Work with the adjacent projects as listed below:
 - a) Georgia Street Bridge Improvements, Project Manager: Alex Sleiman, 619-533-4618; Field Senior Engineer: Frank Gaines, 858-627-3252

- 2-16 CONTRACTOR REGISTRATION AND ELECTRONIC REPORTING SYSTEM.** To the City Supplement, item 1, DELETE in its entirety.

SECTION 4 - CONTROL OF MATERIALS

ADD:

4-1.3.6

Preapproved Materials. To the City Supplement, ADD the following:

3. You shall submit in writing a list of all products to be incorporated in the Work that are on the AML.

4-1.6

Trade Names or Equals. To the City Supplement, ADD the following:

11. You shall submit your list of proposed substitutions for an "equal" item **no less than 15 Working Days prior to the Bid due date** and on the City's Product Submittal Form available at:

<http://www.sandiego.gov/publicworks/edocref/index.shtml>

SECTION 5 - UTILITIES

5-1.1

General. To the City Supplement, ADD the following:

9. When the actual elevation or position of any existing pipe, conduit, or other underground appurtenances, which is shown on the Plans, cannot be determined without excavation, the Contractor shall excavate and expose the existing improvement. Such excavation shall be considered as part of the excavation necessary for the open trench work and no additional compensation will be made therefore. The Engineer shall be given the opportunity to inspect the existing improvement when it is exposed. Any adjustments in line or grade, which may be necessary to accomplish the intent of the Plans, shall be made with the direction and approval of the Engineer, at no additional cost. Continuation of pipeline installation or structure construction for the remainder of project shall proceed only after Engineer provides necessary design adjustments. In the event obstructions are encountered during the progress of the work, which require a deviation from the line and grade shown on the Plans, the Engineer shall have the authority to change the Plans and order the necessary deviation from the line or grade. Contractor shall not make any deviation from the specified line or grade without approval by the Engineer.
10. All surface or groundwater shall be prevented from entering the pipe and shall be removed from the trench in an approved manner.
11. Contractor shall excavate and expose the existing improvements (potholes) at the locations as marked on the ground and any other locations deemed necessary by the Engineer. Such excavation shall be performed as part of the storm drain construction project. However, said utility potholing shall be performed far enough in advance of the storm drain pipe installation operation so as to allow the Engineer at least two

(2) working days to redesign the storm drain alignment, if so required, due to an unforeseen utility conflict. Failure to pothole all known existing utility crossings in advance of the open trench pipe and structure installation, to confirm their exact depth and location, shall not relieve the Contractor from the obligation to provide the Engineer adequate time for potential redesign or expose the City to any potential claims for related delays or related reconstruction of affected portions of storm drain improvements in the event that they are required to be constructed in a new alignment or profile.

5-2 PROTECTION. To the City Supplement, item 2, ADD the following:

- g) Refer to Appendix "H" for more information on the protection of AMI devices.

5-6 COOPERATION. ADD the following:

- 1. Notify SDG&E at least 10 Working Days prior to excavating within 10 feet of SDG&E Underground High Voltage Transmission Power Lines (69 KV and higher).

SECTION 6 - PROSECUTION, PROGRESS AND ACCEPTANCE OF WORK

6-3.2.1.1 Environmental Document.

- 1. The City of San Diego Development Services Department has prepared a Notice of Exemption for ADA Group 13I North Park DIF CR, B-13111.02.06, as referenced in the Contract Appendix. You shall comply with all requirements of the Notice of Exemption as set forth in Appendix A.
- 2. Compliance with the City's environmental document shall be included in the Contract Price, unless separate bid items have been provided.

6-7.1 General. To the City Supplement, ADD the following:

- 4. The work on University Avenue and Crestwood Place shall be completed as the first order of work.

SECTION 7 - RESPONSIBILITIES OF THE CONTRACTOR

7-3 INSURANCE. DELETE in its entirety and SUBSTITUTE with the following:

7-3 INSURANCE.

- 1. The insurance provisions herein shall not be construed to limit your indemnity obligations contained in the Contract.

7-3.1

Policies and Procedures.

1. You shall procure the insurance described below, at its sole cost and expense, to provide coverage against claims for loss including injuries to persons or damage to property, which may arise out of or in connection with the performance of the Work by you, your agents, representatives, officers, employees or Subcontractors.
2. Insurance coverage for property damage resulting from your operations is on a replacement cost valuation. The market value will not be accepted.
3. You shall maintain this insurance for the duration of this Contract and at all times thereafter when you are correcting, removing, or replacing Work in accordance with this Contract. Your liabilities under the Contract, e.g., your indemnity obligations, is not deemed limited to the insurance coverage required by this Contract.
4. The payment for insurance shall be included in the Contract Price as bid by you. Except as specifically agreed to by the City in writing, you are not entitled to any additional payment. Do not begin any Work under this Contract until you have provided and the City has approved all required insurance.
5. Policies of insurance shall provide that the City is entitled to 30 Days (10 Days for cancellation due to non-payment of premium) prior written notice of cancellation or non-renewal of the policy. Maintenance of specified insurance coverage is a material element of the Contract. Your failure to maintain or renew coverage or to provide evidence of renewal during the term of the Contract may be treated by the City as a material breach of the Contract.

7-3.2

Types of Insurance.

7-3.2.1

Commercial General Liability Insurance.

1. Commercial General Liability Insurance shall be written on the current version of the ISO Occurrence form CG 00 01 07 98 or an equivalent form providing coverage at least as broad.
2. The policy shall cover liability arising from premises and operations, XCU (explosions, underground, and collapse), independent contractors, products/completed operations, personal injury and advertising injury, bodily injury, property damage, and liability assumed under an insured's contract (including the tort liability of another assumed in a business contract).

3. There shall be no endorsement or modification limiting the scope of coverage for either "insured vs. insured" claims or contractual liability. You shall maintain the same or equivalent insurance for at least 10 years following completion of the Work.
4. All costs of defense shall be outside the policy limits. Policy coverage shall be in liability limits of not less than the following:

<u>General Annual Aggregate Limit</u>	<u>Limits of Liability</u>
Other than Products/Completed Operations	\$2,000,000
Products/Completed Operations Aggregate Limit	\$2,000,000
Personal Injury Limit	\$1,000,000
Each Occurrence	\$1,000,000

7-3.2.2 Commercial Automobile Liability Insurance.

1. You shall provide a policy or policies of Commercial Automobile Liability Insurance written on the current version of the ISO form CA 00 01 12 90 or later version or equivalent form providing coverage at least as broad in the amount of \$1,000,000 combined single limit per accident, covering bodily injury and property damage for owned, non-owned, and hired automobiles ("Any Auto").
2. All costs of defense shall be outside the limits of the policy.

7-3.3 Rating Requirements. Except for the State Compensation Insurance Fund, all insurance required by this Contract as described herein shall be carried only by responsible insurance companies with a rating of, or equivalent to, at least "A-, VI" by A.M. Best Company, that are authorized by the California Insurance Commissioner to do business in the State, and that have been approved by the City.

7-3.3.1 Non-Admitted Carriers. The City will accept insurance provided by non-admitted, "surplus lines" carriers only if the carrier is authorized to do business in the State and is included on the List of Approved Surplus Lines Insurers (LASLI list).

All policies of insurance carried by non-admitted carriers shall be subject to all of the requirements for policies of insurance provided by admitted carriers described herein.

7-3.4 Evidence of Insurance. Furnish to the City documents e.g., certificates of insurance and endorsements evidencing the insurance required herein, and furnish renewal documentation prior to expiration of this insurance. Each required document shall be signed by the insurer or a person authorized by the insurer to bind coverage on its behalf. We reserve the right to require complete, certified copies of all insurance policies required herein.

7-3.5 Policy Endorsements.

7-3.5.1 Commercial General Liability Insurance.

7-3.5.1.1 Additional Insured.

1. You shall provide at your expense policy endorsement written on the current version of the ISO Occurrence form CG 20 10 11 85 or an equivalent form providing coverage at least as broad.
2. To the fullest extent allowed by law e.g., California Insurance Code §11580.04, the policy shall be endorsed to include the City and its respective elected officials, officers, employees, agents, and representatives as additional insured.
3. The additional insured coverage for projects for which the Engineer's Estimate is \$1,000,000 or more shall include liability arising out of:
 - a) Ongoing operations performed by you or on your behalf,
 - b) your products,
 - c) your Work, e.g., your completed operations performed by you or on your behalf, or
 - d) premises owned, leased, controlled, or used by you.
4. The additional insured coverage for projects for which the Engineer's Estimate is less than \$1,000,000 shall include liability arising out of:
 - a) Ongoing operations performed by you or on your behalf,
 - b) your products, or
 - c) premises owned, leased, controlled, or used by you.

7-3.5.1.2 Primary and Non-Contributory Coverage. The policy shall be endorsed to provide that the coverage with respect to operations, including the completed operations, if appropriate, of the Named Insured is primary to any insurance or self-insurance of the City and its elected officials, officers, employees, agents and representatives. Further, it shall provide that any insurance maintained by the City and its elected officials, officers, employees, agents and representatives shall be in excess of your insurance and shall not contribute to it.

7-3.5.1.3 Project General Aggregate Limit. The policy or policies shall be endorsed to provide a Designated Construction Project General Aggregate Limit that will apply only to the Work. Only claims payments which arise from the Work shall reduce the Designated Construction Project General Aggregate Limit. The Designated Construction Project General Aggregate Limit shall be in addition to the aggregate limit provided for the products-completed operations hazard.

7-3.5.2 Commercial Automobile Liability Insurance.

7-3.5.2.1 Additional Insured. Unless the policy or policies of Commercial Auto Liability Insurance are written on an ISO form CA 00 01 12 90 or a later version of this form or equivalent form providing coverage at least as broad, the policy shall be endorsed to include the City and its respective elected officials, officers, employees, agents, and representatives as additional insured, with respect to liability arising out of automobiles owned, leased, hired or borrowed by you or on your behalf. This endorsement is limited to the obligations permitted by California Insurance Code §11580.04.

7-3.6 Deductibles and Self-Insured Retentions. You shall pay for all deductibles and self-insured retentions. You shall disclose deductibles and self-insured retentions to the City at the time the evidence of insurance is provided.

7-3.7 Reservation of Rights. The City reserves the right, from time to time, to review your insurance coverage, limits, deductibles and self-insured retentions to determine if they are acceptable to the City. The City will reimburse you, without overhead, profit, or any other markup, for the cost of additional premium for any coverage requested by the Engineer but not required by this Contract.

7-3.8 Notice of Changes to Insurance. You shall notify the City 30 Days prior to any material change to the policies of insurance provided under this Contract.

7-3.9 Excess Insurance. Policies providing excess coverage shall follow the form of the primary policy or policies e.g., all endorsements.

7-3.10 Architects and Engineers Professional Insurance (Errors and Omissions Insurance)

1. For Contracts with required engineering services (e.g., Design-Build, preparation of engineered Traffic Control Plans (TCP), and etc) by you, you shall keep or require all of your employees or Subcontractors, who provide professional engineering services under this contract, Professional Liability coverage with a limit of **\$1,000,000** per claim and **\$2,000,000** annual aggregate in full force and effect.
2. You shall ensure the following:
 - a) The policy retroactive date is on or before the date of commencement of the Project.
 - b) The policy will be maintained in force for a period of 3 years after completion of the Project or termination of this Contract, whichever occurs last. You agree that for the time period specified

above, there will be no changes or endorsements to the policy that affect the specified coverage.

3. If professional engineering services are to be provided solely by the Subcontractor, you shall:
 - a) Certify this to the City in writing and
 - b) Agree in writing to require the Subcontractor to procure Professional Liability coverage in accordance with the requirements set forth above.

7-4 **NOT USED.** DELETE in its entirety and SUBSTITUTE with the following:

7-4 **WORKERS' COMPENSATION INSURANCE AND EMPLOYERS LIABILITY INSURANCE.**

1. In accordance with the provisions of §3700 of the California Labor Code, you shall provide at your expense Workers' Compensation Insurance and Employers Liability Insurance to protect you against all claims under applicable state workers compensation laws. The City, its elected officials, and employees will not be responsible for any claims in law or equity occasioned by your failure to comply with the requirements of this section.

2. Limits for this insurance shall be not less than the following:

<u>Workers' Compensation</u>	<u>Statutory Employers Liability</u>
Bodily Injury by Accident	\$1,000,000 each accident
Bodily Injury by Disease	\$1,000,000 each employee
Bodily Injury by Disease	\$1,000,000 policy limit

3. By signing and returning the Contract you certify that you are aware of the provisions of §3700 of the Labor Code which requires every employer to be insured against liability for worker's compensation or to undertake self-insurance in accordance with the provisions of that code and you shall comply with such provisions before commencing the Work as required by §1861 of the California Labor Code.

7-4.1 **Waiver of Subrogation.** The policy or policies shall be endorsed to provide that the insurer will waive all rights of subrogation against the City and its respective elected officials, officers, employees, agents, and representatives for losses paid under the terms of the policy or policies and which arise from Work performed by the Named Insured for the City.

7-5 PERMITS, FEES, AND NOTICES. To the City Supplement, ADD the following:

2. The City will obtain, at no cost to you, the following permits:
 - a) Private Property Permit for University Avenue and Crestwood Place
 - b) Private Property Permit for Thorn Street and 32nd Street

7-10.5.3 Steel Plate Covers. To the City Supplement, ADD the following:

14. In the event the use of steel plating is necessary, the Contractor shall grind pavement (in areas of existing pavement) to a depth equal to the thickness of the steel plate used. Grinding limits shall encompass the width of the plate so as to create a flush surface transition. Temporary asphalt ramps at steel plates shall not be allowed. Payment for all materials used by the Contractor or ordered to be placed by the Engineer, including that used to maintain the temporary resurfacing until the permanent resurfacing is placed, will be considered to be included in the other items of work.

7-20 ELECTRONIC COMMUNICATION. To the City Supplement, ADD the following:

2. Virtual Project Manager shall be used on this Contract.

7-21.1 General. To the City Supplement, Item 3, DELETE in its entirety and SUBSTITUTE with the following:

3. During the construction phase of projects, the minimum waste management reduction goal is 90% of the inert material (a material not subject to decomposition such as concrete, asphalt, brick, rock, block, dirt, metal, glass, and etc.) and 65% of the remaining project waste. You shall provide appropriate documentation, including a Waste Management Form attached as an appendix, and evidence of recycling and reuse of materials to meet the waste reduction goals specified.

SECTION 9 - MEASUREMENT AND PAYMENT

ADD:

9-3.7 Compensation Adjustments for Price Index Fluctuations. To the City Supplement ADD the following:

5. This Contract is not subject to the provisions of The "WHITEBOOK" for Compensation Adjustments for Price Index Fluctuations for paving asphalt.

SECTION 300 – CLEARING AND GRUBBING

300-1.3.1 **General.** ADD the following:

The Contractor shall remove all debris from the project site by the end of each work day.

300-1.4 **Payment.** To the City Supplement, ADD the following:

8. The lump sum price for Clearing and Grubbing shall include full compensation for the sawcutting, demolition, removal, and disposal of all existing improvements (up to 24") including, but not limited to, soil, pavement (Asphalt Concrete, PCC, Base, Unclassified Materials, curb and gutter, signs and sign posts, inlets, cleanouts, and all other existing improvements that are in conflict with the proposed work, directed by the Engineer to be removed, or otherwise required to perform the work.

300-4.10 **Payment.** DELETE in its entirety and SUBSTITUTE with the following:

The contract unit price bid for Unclassified Excavation and Fill shall include full compensation for all cost necessary for excavating/grading pavement sections, unclassified fill material, placement, water, compaction, and grading to the lines, grades, and cross sections, excess dirt behind new sidewalks and driveways including the removal, sloping, grading, compaction, rounding tops and ends of excavation, treatment, storage, stockpiling, transportation within the project side, loading, disposal, export, and hauling of unsuitable, wet, or surplus material off site. Fill work shall include over-excavation and re-compaction of existing subgrade soils to achieve subgrade compaction prior to the placement of fill, placement, and filling and grading, stockpiling, loading, and hauling to final location and disposing of surplus material at a legal disposal site and all work included with this Section and Section 300-2. Payment for clearing and grubbing shall conform to 300-1.4 No additional payments will be made for chemical additives, bulking, subsidence, shrinkage, temporary erosion control measures, or benching.

SECTION 301 – TREATED SOIL, SUBGRADE PREPARATION, PLACEMENT OF BASE MATERIALS

301-1.7 **Payment.** To the City Supplement, ADD the following:

7. Payment for adjusting existing pull box to grade shall be made at the Contract Unit price for Adjust Pull Box to Grade.
8. Payment for adjusting existing parking meter to grade shall be made at the Contract Unit price for Adjust Parking Meter to Grade.

SECTION 302 – ROADWAY SURFACING

302-4.12.2.1 General. To the City Supplement, ADD the following:

3. When Type I is to be applied over Type III, corrective action in accordance with 302-4.11.1.2, "Reduction in Payment Based on WTAT" such as reductions in payment, non-payment, or removal of Type III material not meeting specifications as directed by the Engineer shall be executed prior to the application of the Type I material.

302-7.4 Payment. To the City Supplement, item 1, last sentence, DELETE in its entirety and SUBSTITUTE with the following:

Payment shall not be made for additional fabric for overlapped areas.

SECTION 303 – CONCRETE AND MASONRY CONSTRUCTION

303-5.9 Measurement and Payment. To the City Supplement, ADD the following:

7. The payment for the square foot bid item of Remove and Replace Existing Sidewalk shall include full compensation for all labor, materials, excavation, grading, equipment, and incidentals required to remove and install PCC Sidewalks per plan, per specifications, and as directed by the Resident Engineer.
8. Payment for linear feet of Type "G" Curb & Gutter per SDG-151 shall include full compensation for all labor, materials, grading, equipment, and incidentals required to install curb and gutter in all locations including adjacent to driveways and curb transitions from new curb to existing curb, per plan, per specifications, and as directed by the Engineer.
9. The lump sum price for Concrete Steps and handrails shall include full compensation for all labor, materials, excavation, grading, equipment, and incidentals required to install Concrete Steps and handrails, per plan, per specifications, and as directed by the Engineer.

303-5.10.1 Installation. To the City Supplement, ADD the following:

8. The Contractor shall be solely responsible for means and methods for laying out and verifying all proposed curb ramps' and appurtenances' grades, including all associated sidewalks, curbs, and gutter plates, in accordance with the City of San Diego Standard Drawings and as indicated in the construction documents. The final grades for all constructed curb ramps and appurtenances shall not exceed maximum grades indicated in City of San Diego Standard Drawings and the construction documents. There shall be no construction tolerances allowed. Any curb ramps or appurtenances constructed in excess of maximum grades as indicated in the aforementioned documents shall be removed and replaced at the Contractor's sole expense.

9. Removal and disposal of AC pavement, existing concrete including curb and gutter or portion of spandrel as occurs, and sidewalk necessary to construct the ramp shall be made as straight edges and by the full depth saw cutting only. Removal limits shall be agreed to in writing prior to the saw cutting operation for each ramp location.
10. The Contractor shall submit traffic control Working Drawing including pedestrian access through construction zone with the approved signage in accordance with 2-5.3, "Submittals." The Contractor shall notify residents adjacent to the construction area at least 10 Working Days prior to any sidewalk or Driveway demolition. The Contractor may demolish those curb ramps that can be replaced within the same Working Day.
11. Concrete within the curb ramps shall match existing concrete color per Section 303-7 Colored Concrete Installation.

303-5.10.2 Payment. To the City Supplement, items 1 and 2, DELETE in their entirety and SUBSTITUTE with the following:

1. The payment for each curb ramp shall include transition areas, landings, DWTs, demolition and disposal, forming, relocating or raising items in conflict to grade, protecting and preserving existing survey monuments and improvements, restoring pavement, removal of and construction of curb, curb and gutter, AC pavement, removal of existing ramps and sidewalk associated with ramp construction and construction of curb, gutter, and sidewalks in place, as necessary to achieve ADA compliant grades (regardless of replacement limits shown on the plans) and construction staking complete in place as specified in the special provisions and as directed by the Engineer.
2. The payment for each modified curb ramp shall include transition areas, landings, DWTs, demolition and disposal, forming, relocating or raising items in conflict to grade, protecting and preserving existing survey monuments and improvements, restoring pavement, removal of and construction of curb, curb and gutter, AC pavement, removal of existing ramps and sidewalk associated with ramp construction and construction of curb, gutter, and sidewalks in place, as necessary to achieve ADA compliant grades (regardless of replacement limits shown on the plans) and construction staking complete in place as specified in the special provisions and as directed by the Engineer.

303-5.10.2 Payment. To the City Supplement, ADD the following:

4. The payment for Curb Ramp Modified at Laurel Street and 30th Street Intersection shall include colored concrete transition areas, colored concrete landings, DWTs, demolition and disposal, forming, relocating or raising items in conflict to grade, protecting and preserving existing survey

monuments and improvements, restoring pavement, removal of and construction of colored curb, colored curb and gutter, AC pavement, removal of existing ramps and sidewalk associated with ramp construction and construction of colored curb, gutter, and sidewalks in place, as necessary to achieve ADA compliant grades (regardless of replacement limits shown on the plans) and construction staking complete in place as specified in the special provisions and as directed by the Engineer.

303-7.1 **General.** DELETE in its entirety and SUBSTITUTE with the following:

Colored concrete shall be produced by Method B. The Contractor shall provide two samples of color for each color specified of a size satisfactory to the Engineer at least two weeks prior to the completion of the colored concrete work. The sample shall be inspected and approved in writing by the Engineer before proceeding with the Work. Color for sidewalk, curb, gutter, and curb ramp transitions at the Laurel Street and 30th Street Intersection shall be Davis color Brick Red 160 or approved equal to match existing colored concrete.

303-7.2 **Method A (Dry Shake).** DELETE in its entirety.

SECTION 304 – METAL FABRICATION AND CONSTRUCTION

304-5 **PAYMENT.** To the City Supplement, REVISE section “304-5” to “304-6”.

SECTION 306 – OPEN TRENCH CONDUIT CONSTRUCTION

306-3.4 **Minimum and Maximum Pipe Zone Trench Width.** ADD the following:

For all RCP pipe sizes, the minimum trench width shall be the outside diameter of the pipe plus sixteen inches, and the maximum trench width shall be the outside diameter of the pipe plus twenty-four inches.

306-3.5 **Maximum Length of Open Trench.** DELETE in its entirety and SUBSTITUTE with the following:

Except by permission of the Engineer, the maximum length of open trench where prefabricated pipe is installed shall be the distance necessary to accommodate the amount of pipe installed in a single day. Opening up more trench than pipe can be completely installed in one day shall not be allowed.

306-6.1 **Bedding.** To the City Supplement, DELETE the last two paragraphs and SUBSTITUTE with the following:

The Contractor shall not perform open trench operations until storm drain pipe is present on-site. Trenching while pipe sections are in transit shall not be allowed.

The trench bottom shall be graded to provide a smooth, straight, firm and stable foundation at every point throughout the length of the pipe. At each joint in the pipe, the bedding shall be recessed in such manner as to relieve the bell, or coupling, if any, from all loads and to ensure continuous bearing along the pipe barrel. The recess shall be large enough to allow jointing of the pipe without foreign material entering the pipe.

If any trench, through the neglect of the Contractor, is excavated below the grade required by the Plans, Standard Specifications, and/or these Special Provisions, it shall be refilled to grade with additional acceptable bedding per these special provisions. Additional bedding shall be ¾-inch crushed rock in accordance with Section 200-2 of the Standard Specifications and these Special Provisions. The excess excavation and the additional bedding shall be at no expense to the City.

The trench bottom shall be over-excavated at least 6-inches below the proposed grade of the bottom of the pipe. The trench shall then be refilled with ¾" crushed aggregate and graded to provide a smooth, firm, and stable foundation along the entire length of the pipe. At each pipe joint, the bedding material shall be recessed so the pipe may be readily assembled and in such a manner as to relieve the bell or coupling from all load when assembling the joint and prevent foreign material from entering the pipe.

306-12.1 General. To the City Supplement, ADD the following

3. Soil removed from the excavation can be used for backfill, provided cobbles and boulders exceeding three inches in maximum dimension, and any organically contaminated soils, are removed. Imported material to be used for backfill shall not contain rocks, greater than three inches in maximum dimension or organic debris, and shall have a sand equivalent of 30 or greater.

All trench backfill and bedding shall be compacted to 95% relative compaction minimum. Jetting of backfill shall not be allowed.

306-13.2 Permanent Resurfacing. To the City Supplement, ADD the following:

3. Existing paved surfaces shall be cut 6 inches back beyond the edges of the trenches to form neat square cuts after backfill and before repaving is commenced. Should it be necessary to increase the width of permanent resurfacing due to pavement deterioration beyond areas within the trench, a secondary saw-cut and additional pavement removal may be required by the City prior to final patching of the pavement. Removal of such additional pavement areas will be included in the other bid items, and no additional compensation shall be made therefore.

306-15.2 Shoring and Bracing. To the City Supplement, Item 1, ADD the following:

Payment for trench shoring and bracing shall be made at the contract lump sum price and shall include full compensation for all shoring plans prepared by a registered engineer, labor, materials, tools, equipment and all costs relating to trench safety and shoring of excavations including temporary steel plating, temporary AC paving, all costs for obtaining said permit from the Division of Industrial Safety as described herein and all costs for additional customized structural calculations required by the contemplated improvements, and no additional compensation shall be allowed therefore.

SECTION 314 – TRAFFIC STRIPING, CURB AND PAVEMENT MARKINGS, AND PAVEMENT MARKERS

314-4.4.6 Payment. To the City Supplement, Item 1, DELETE and SUBSITUTE the following:

1. No separate payment shall be made for establishing alignment for stripes, layout Work, control points necessary to re-establish the striping and pavement markings to match existing striping and pavement markings, in their original locations or as shown on the plans (in the case of conflict, the plans shall take precedence).

The payment for removing and relocating signs shall be included in the bid item for "Remove and Relocate Traffic Signs"

EQUAL OPPORTUNITY CONTRACTING PROGRAM (EOCP) SECTION A – GENERAL REQUIREMENTS

4.1 Nondiscrimination in Contracting Ordinance. To the City Supplement, subsection 4.1.1, paragraph (2), sentence (1), DELETE in its entirety and SUBSTITUTE with the following:

You shall not discriminate on the basis of race, gender, gender expression, gender identity, religion, national origin, ethnicity, sexual orientation, age, or disability in the solicitation, selection, hiring, or treatment of subcontractors, vendors, or suppliers.

END OF SUPPLEMENTARY SPECIAL PROVISIONS (SSP)

SUPPLEMENTARY SPECIAL PROVISIONS

APPENDICES

APPENDIX A
NOTICE OF EXEMPTION

NOTICE OF EXEMPTION

(Check one or both)

TO: Recorder/County Clerk
P.O. Box 1750, MS A-33
1600 Pacific Hwy, Room 260
San Diego, CA 92101-2400

FROM: City of San Diego
Development Services Department
1222 First Avenue, MS 501
San Diego, CA 92101

Office of Planning and Research
1400 Tenth Street, Room 121
Sacramento, CA 95814

Project No.: B-13111.02.06

Project Title: ADA Group 13 | North Park DIF CR

Project Location-Specific: The project is located at the following intersections within the community of North Park (Council District 3): 32nd Street and Thorn Street, 30th Street and Laurel Street, and University Avenue and Crestwood Place. A portion of the work occurring at 30th Street and Laurel Street is located within the Burlingame Historic District.

Description of nature and purpose of the Project: The project would include upgrading the above three roadway intersections to meet ADA compliance for disabled paths of travel, as further described below.

Intersection of 32nd Street and Thorn Street:

Install a curb ramp, relocate an existing storm drain pipe and inlet, and resurface a street section and driveways. The existing storm drain inlet will be relocated approximately 20 feet north of the existing storm drain along the west side of 32nd Street. The new storm drain pipe will be 14' in length, and storm drain improvements will have a maximum depth of 9 feet. An existing storm drain cleanout will be replaced.

Intersection of 30th Street and Laurel Street:

Install four (4) ADA compliant curb ramps, remove and replace sidewalk and curb and gutter; relocate an existing street light; and relocate/adjust existing utilities, signs, and parking meters. No historic stamps would be impacted by the project improvements. However, the project will include requirements for preservation and relocation of historical stamps per City of San Diego Whitebook specifications, if necessary. Sidewalk, curb and gutter and curb ramp improvements would be required to match the existing sidewalk color and scoring patterns within the Burlingame historic district.

Intersection of University Avenue and Crestwood Place:

Install two (2) ADA compliant curb ramps, steps and alley apron; remove and replace sidewalk and curb and gutter; relocate/adjust existing utilities, signs, and parking meters; and preserve and relocate historical stamps per City of San Diego Whitebook specifications.

Name of Public Agency Approving Project: City of San Diego

Name of Person or Agency Carrying Out Project: City of San Diego Public Works Department
Sabeen Cochinwala, Project Manager
525 B Street, Suite 750,
San Diego, CA 92101
619.533.4661

Exempt Status: (CHECK ONE)

() Ministerial (Sec. 21080(b)(1); 15268);

- Declared Emergency (Sec. 21080(b)(3); 15269(a));
- Emergency Project (Sec. 21080(b)(4); 15269(b)(c))
- Categorical Exemption: Sec. 15301 (Existing Facilities), 15302 (Replacement or Reconstruction) and 15303 (New Construction)
- Statutory Exemptions:

REASONS WHY PROJECT IS EXEMPT: The City of San Diego conducted an environmental review and determined the project meets the categorical exemption criteria set forth in the CEQA State Guidelines §15301 (EXISTING FACILITIES), which allows for repair, maintenance, and minor alteration of existing public structures, facilities and mechanical equipment involving negligible or no expansion of use; §15302 (REPLACEMENT OR RECONSTRUCTION), which allows for replacement or reconstruction of existing structures and facilities where the new structure will be located on the same site as the structure replaced and will have substantially the same purpose and capacity as the structure replaced including public utility systems and street improvements; §15303 (NEW CONSTRUCTION), which includes construction of limited new, small facilities or structures including, but not limited to new public utility improvements; and does not trigger any of the exceptions to categorical exemptions found in CEQA Guidelines §15300.2. All work would occur within the developed public right of way within disturbed soils. Storm drain improvements would not occur within the City's mapped archaeological sensitivity area, and historical stamps would be preserved and relocated in accordance with the City's Whitebook specifications. Sidewalk, curb and gutter and curb ramp improvements would match the existing sidewalk color and scoring patterns within the Burlingame historic district. All improvements within the historic district would be consistent with the City's Historic Resources Regulations. Therefore, no adverse impacts to historical resources are anticipated.

Lead Agency Contact Person: James Arnhart, Senior Planner

Telephone: (619) 533-5275

If filed by applicant:

1. Attach certified document of exemption finding.
2. Has a notice of exemption been filed by the public agency approving the project? Yes No

It is hereby certified that the City of San Diego has determined the above activity to be exempt from CEQA

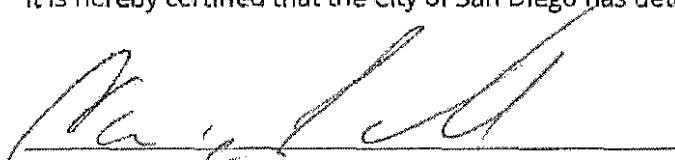

 Carrie Purcell, Principal Planner

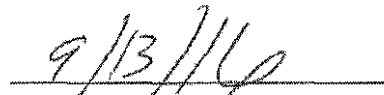

 Date

Check One:

- Signed By Lead Agency
- Signed by Applicant

Date Received for Filing with County Clerk or OPR:

APPENDIX B
FIRE HYDRANT METER PROGRAM

CITY OF SAN DIEGO CALIFORNIA DEPARTMENT INSTRUCTIONS	NUMBER DI 55.27	DEPARTMENT Water Department
SUBJECT FIRE HYDRANT METER PROGRAM (FORMERLY: CONSTRUCTION METER PROGRAM)	PAGE 1 OF 10	EFFECTIVE DATE October 15, 2002
	SUPERSEDES DI 55.27	DATED April 21, 2000

1. **PURPOSE**

- 1.1 To establish a Departmental policy and procedure for issuance, proper usage and charges for fire hydrant meters.

2. **AUTHORITY**

- 2.1 All authorities and references shall be current versions and revisions.
- 2.2 San Diego Municipal Code (NC) Chapter VI, Article 7, Sections 67.14 and 67.15
- 2.3 Code of Federal Regulations, Safe Drinking Water Act of 1986
- 2.4 California Code of Regulations, Titles 17 and 22
- 2.5 California State Penal Code, Section 498B.0
- 2.6 State of California Water Code, Section 110, 500-6, and 520-23
- 2.7 Water Department Director

Reference

- 2.8 State of California Guidance Manual for Cross Connection Programs
- 2.9 American Water Works Association Manual M-14, Recommended Practice for Backflow Prevention
- 2.10 American Water Works Association Standards for Water Meters
- 2.11 U.S.C. Foundation for Cross Connection Control and Hydraulic Research Manual

3. **DEFINITIONS**

- 3.1 **Fire Hydrant Meter:** A portable water meter which is connected to a fire hydrant for the purpose of temporary use. (These meters are sometimes referred to as Construction Meters.)

CITY OF SAN DIEGO CALIFORNIA DEPARTMENT INSTRUCTIONS	NUMBER DI 55.27	DEPARTMENT Water Department
SUBJECT FIRE HYDRANT METER PROGRAM (FORMERLY: CONSTRUCTION METER PROGRAM)	PAGE 2 OF 10	EFFECTIVE DATE October 15, 2002
	SUPERSEDES DI 55.27	DATED April 21, 2000

3.2 **Temporary Water Use:** Water provided to the customer for no longer than twelve (12) months.

3.3 **Backflow Preventor:** A Reduced Pressure Principal Assembly connected to the outlet side of a Fire Hydrant Meter.

4. **POLICY**

4.1 The Water Department shall collect a deposit from every customer requiring a fire hydrant meter and appurtenances prior to providing the meter and appurtenances (see Section 7.1 regarding the Fees and Deposit Schedule). The deposit is refundable upon the termination of use and return of equipment and appurtenances in good working condition.

4.2 Fire hydrant meters will have a 2 ½" swivel connection between the meter and fire hydrant. The meter shall not be connected to the 4" port on the hydrant. All Fire Hydrant Meters issued shall have a Reduced Pressure Principle Assembly (RP) as part of the installation. Spanner wrenches are the only tool allowed to turn on water at the fire hydrant.

4.3 The use of private hydrant meters on City hydrants is prohibited, with exceptions as noted below. All private fire hydrant meters are to be phased out of the City of San Diego. All customers who wish to continue to use their own fire hydrant meters must adhere to the following conditions:

a. Meters shall meet all City specifications and American Water Works Association (AWWA) standards.

b. Customers currently using private fire hydrant meters in the City of San Diego water system will be allowed to continue using the meter under the following conditions:

1. The customer must submit a current certificate of accuracy and calibration results for private meters and private backflows annually to the City of San Diego, Water Department, Meter Shop.

CITY OF SAN DIEGO CALIFORNIA DEPARTMENT INSTRUCTIONS	NUMBER DI 55.27	DEPARTMENT Water Department
SUBJECT FIRE HYDRANT METER PROGRAM (FORMERLY: CONSTRUCTION METER PROGRAM)	PAGE 3 OF 10	EFFECTIVE DATE October 15, 2002
	SUPERSEDES DI 55.27	DATED April 21, 2000

2. The meter must be properly identifiable with a clearly labeled serial number on the body of the fire hydrant meter. The serial number shall be plainly stamped on the register lid and the main casing. Serial numbers shall be visible from the top of the meter casing and the numbers shall be stamped on the top of the inlet casing flange.
3. All meters shall be locked to the fire hydrant by the Water Department, Meter Section (see Section 4.7).
4. All meters shall be read by the Water Department, Meter Section (see Section 4.7).
5. All meters shall be relocated by the Water Department, Meter Section (see Section 4.7).
6. These meters shall be tested on the anniversary of the original test date and proof of testing will be submitted to the Water Department, Meter Shop, on a yearly basis. If not tested, the meter will not be allowed for use in the City of San Diego.
7. All private fire hydrant meters shall have backflow devices attached when installed.
8. The customer must maintain and repair their own private meters and private backflows.
9. The customer must provide current test and calibration results to the Water Department, Meter Shop after any repairs.
10. When private meters are damaged beyond repair, these private meters will be replaced by City owned fire hydrant meters.

CITY OF SAN DIEGO CALIFORNIA DEPARTMENT INSTRUCTIONS	NUMBER DI 55.27	DEPARTMENT Water Department
SUBJECT FIRE HYDRANT METER PROGRAM (FORMERLY: CONSTRUCTION METER PROGRAM)	PAGE 4 OF 10	EFFECTIVE DATE October 15, 2002
	SUPERSEDES DI 55.27	DATED April 21, 2000

11. When a private meter malfunctions, the customer will be notified and the meter will be removed by the City and returned to the customer for repairs. Testing and calibration results shall be given to the City prior to any re-installation.
12. The register shall be hermetically sealed straight reading and shall be readable from the inlet side. Registration shall be in hundred cubic feet.
13. The outlet shall have a 2 ½ "National Standards Tested (NST) fire hydrant male coupling.
14. Private fire hydrant meters shall not be transferable from one contracting company to another (i.e. if a company goes out of business or is bought out by another company).

4.4 All fire hydrant meters and appurtenances shall be installed, relocated and removed by the City of San Diego, Water Department. All City owned fire hydrant meters and appurtenances shall be maintained by the City of San Diego, Water Department, Meter Services.

4.5 If any fire hydrant meter is used in violation of this Department Instruction, the violation will be reported to the Code Compliance Section for investigation and appropriate action. Any customer using a fire hydrant meter in violation of the requirements set forth above is subject to fines or penalties pursuant to the Municipal Code, Section 67.15 and Section 67.37.

4.6 Conditions and Processes for Issuance of a Fire Hydrant Meter

Process for Issuance

- a. Fire hydrant meters shall only be used for the following purposes:
 1. Temporary irrigation purposes not to exceed one year.

CITY OF SAN DIEGO CALIFORNIA DEPARTMENT INSTRUCTIONS	NUMBER DI 55.27	DEPARTMENT Water Department
SUBJECT FIRE HYDRANT METER PROGRAM (FORMERLY: CONSTRUCTION METER PROGRAM)	PAGE 5 OF 10	EFFECTIVE DATE October 15, 2002
	SUPERSEDES DI 55.27	DATED April 21, 2000

2. Construction and maintenance related activities (see Tab 2).
 - b. No customer inside or outside the boundaries of the City of San Diego Water Department shall resell any portion of the water delivered through a fire hydrant by the City of San Diego Water Department.
 - c. The City of San Diego allows for the issuance of a temporary fire hydrant meter for a period not to exceed 12 months (365 days). An extension can only be granted in writing from the Water Department Director for up to 90 additional days. A written request for an extension by the consumer must be submitted at least 30 days prior to the 12 month period ending. No extension shall be granted to any customer with a delinquent account with the Water Department. No further extensions shall be granted.
 - d. Any customer requesting the issuance of a fire hydrant meter shall file an application with the Meter Section. The customer must complete a "Fire Hydrant Meter Application" (Tab 1) which includes the name of the company, the party responsible for payment, Social Security number and/or California ID, requested location of the meter (a detailed map signifying an exact location), local contact person, local phone number, a contractor's license (or a business license), description of specific water use, duration of use at the site and full name and address of the person responsible for payment.
 - e. At the time of the application the customer will pay their fees according to the schedule set forth in the Rate Book of Fees and Charges, located in the City Clerk's Office. All fees must be paid by check, money order or cashiers check, made payable to the City Treasurer. Cash will not be accepted.
 - f. No fire hydrant meters shall be furnished or relocated for any customer with a delinquent account with the Water Department.
 - g. After the fees have been paid and an account has been created, the

CITY OF SAN DIEGO CALIFORNIA DEPARTMENT INSTRUCTIONS	NUMBER DI 55.27	DEPARTMENT Water Department
SUBJECT FIRE HYDRANT METER PROGRAM (FORMERLY: CONSTRUCTION METER PROGRAM)	PAGE 6 OF 10	EFFECTIVE DATE October 15, 2002
	SUPERSEDES DI 55.27	DATED April 21, 2000

meter shall be installed within 48 hours (by the second business day). For an additional fee, at overtime rates, meters can be installed within 24 hours (within one business day).

4.7 Relocation of Existing Fire Hydrant Meters

- a. The customer shall call the Fire Hydrant Meter Hotline (herein referred to as "Hotline"), a minimum of 24 hours in advance, to request the relocation of a meter. A fee will be charged to the existing account, which must be current before a work order is generated for the meter's relocation.
- b. The customer will supply in writing the address where the meter is to be relocated (map page, cross street, etc). The customer must update the original Fire Hydrant Meter Application with any changes as it applies to the new location.
- c. Fire hydrant meters shall be read on a monthly basis. While fire hydrant meters and backflow devices are in service, commodity, base fee and damage charges, if applicable, will be billed to the customer on a monthly basis. If the account becomes delinquent, the meter will be removed.

4.8 Disconnection of Fire Hydrant Meter

- a. After ten (10) months a "Notice of Discontinuation of Service" (Tab 3) will be issued to the site and the address of record to notify the customer of the date of discontinuance of service. An extension can only be granted in writing from the Water Department Director for up to 90 additional days (as stated in Section 4.6C) and a copy of the extension shall be forwarded to the Meter Shop Supervisor. If an extension has not been approved, the meter will be removed after twelve (12) months of use.
- b. Upon completion of the project the customer will notify the Meter Services office via the Hotline to request the removal of the fire hydrant meter and appurtenances. A work order will be generated

CITY OF SAN DIEGO CALIFORNIA DEPARTMENT INSTRUCTIONS	NUMBER DI 55.27	DEPARTMENT Water Department
SUBJECT FIRE HYDRANT METER PROGRAM (FORMERLY: CONSTRUCTION METER PROGRAM)	PAGE 7 OF 10	EFFECTIVE DATE October 15, 2002
	SUPERSEDES DI 55.27	DATED April 21, 2000

for removal of the meter.

- c. Meter Section staff will remove the meter and backflow prevention assembly and return it to the Meter Shop. Once returned to the Meter Shop the meter and backflow will be tested for accuracy and functionality.
- d. Meter Section Staff will contact and notify Customer Services of the final read and any charges resulting from damages to the meter and backflow or its appurtenance. These charges will be added on the customer's final bill and will be sent to the address of record. Any customer who has an outstanding balance will not receive additional meters.
- e. Outstanding balances due may be deducted from deposits and any balances refunded to the customer. Any outstanding balances will be turned over to the City Treasurer for collection. Outstanding balances may also be transferred to any other existing accounts.

5. **EXCEPTIONS**

- 5.1 Any request for exceptions to this policy shall be presented, in writing, to the Customer Support Deputy Director, or his/her designee for consideration.

6. **MOBILE METER**

- 6.1 Mobile meters will be allowed on a case by case basis. All mobile meters will be protected by an approved backflow assembly and the minimum requirement will be a Reduced Pressure Principal Assembly. The two types of Mobile Meters are vehicle mounted and floating meters. Each style of meters has separate guidelines that shall be followed for the customer to retain service and are described below:
 - a) **Vehicle Mounted Meters:** Customer applies for and receives a City owned Fire Hydrant Meter from the Meter Shop. The customer mounts the meter on the vehicle and brings it to the Meter Shop for

CITY OF SAN DIEGO CALIFORNIA DEPARTMENT INSTRUCTIONS	NUMBER DI 55.27	DEPARTMENT Water Department
SUBJECT FIRE HYDRANT METER PROGRAM (FORMERLY: CONSTRUCTION METER PROGRAM)	PAGE 8 OF 10	EFFECTIVE DATE October 15, 2002
	SUPERSEDES DI 55.27	DATED April 21, 2000

inspection. After installation is approved by the Meter Shop the vehicle and meter shall be brought to the Meter Shop on a monthly basis for meter reading and on a quarterly basis for testing of the backflow assembly. Meters mounted at the owner's expense shall have the one year contract expiration waived and shall have meter or backflow changed if either fails.

- b) **Floating Meters:** Floating Meters are meters that are not mounted to a vehicle. **(Note: All floating meters shall have an approved backflow assembly attached.)** The customer shall submit an application and a letter explaining the need for a floating meter to the Meter Shop. The Fire Hydrant Meter Administrator, after a thorough review of the needs of the customer, (i.e. number of jobsites per day, City contract work, lack of mounting area on work vehicle, etc.), may issue a floating meter. At the time of issue, it will be necessary for the customer to complete and sign the "Floating Fire Hydrant Meter Agreement" which states the following:

- 1) The meter will be brought to the Meter Shop at 2797 Caminito Chollas, San Diego on the third week of each month for the monthly read by Meter Shop personnel.
- 2) Every other month the meter will be read and the backflow will be tested. This date will be determined by the start date of the agreement.

If any of the conditions stated above are not met the Meter Shop has the right to cancel the contract for floating meter use and close the account associated with the meter. The Meter Shop will also exercise the right to refuse the issuance of another floating meter to the company in question.

Any Fire Hydrant Meter using reclaimed water shall not be allowed use again with any potable water supply. The customer shall incur the cost of replacing the meter and backflow device in this instance.

CITY OF SAN DIEGO CALIFORNIA DEPARTMENT INSTRUCTIONS	NUMBER DI 55.27	DEPARTMENT Water Department
SUBJECT FIRE HYDRANT METER PROGRAM (FORMERLY: CONSTRUCTION METER PROGRAM)	PAGE 9 OF 10	EFFECTIVE DATE October 15, 2002
	SUPERSEDES DI 55.27	DATED April 21, 2000

7. **FEE AND DEPOSIT SCHEDULES**

7.1 **Fees and Deposit Schedules:** The fees and deposits, as listed in the Rate Book of Fees and Charges, on file with the Office of the City Clerk, are based on actual reimbursement of costs of services performed, equipment and materials. These deposits and fees will be amended, as needed, based on actual costs. Deposits, will be refunded at the end of the use of the fire hydrant meter, upon return of equipment in good working condition and all outstanding balances on account are paid. Deposits can also be used to cover outstanding balances.

All fees for equipment, installation, testing, relocation and other costs related to this program are subject to change without prior notification. The Mayor and Council will be notified of any future changes.

8. **UNAUTHORIZED USE OF WATER FROM A HYDRANT**

8.1 Use of water from any fire hydrant without a properly issued and installed fire hydrant meter is theft of City property. Customers who use water for unauthorized purposes or without a City of San Diego issued meter will be prosecuted.

8.2 If any unauthorized connection, disconnection or relocation of a fire hydrant meter, or other connection device is made by anyone other than authorized Water Department personnel, the person making the connection will be prosecuted for a violation of San Diego Municipal Code, Section 67.15. In the case of a second offense, the customer's fire hydrant meter shall be confiscated and/or the deposit will be forfeited.

8.3 Unauthorized water use shall be billed to the responsible party. Water use charges shall be based on meter readings, or estimates when meter readings are not available.

8.4 In case of unauthorized water use, the customer shall be billed for all applicable charges as if proper authorization for the water use had been obtained, including but not limited to bi-monthly service charges, installation charges and removal charges.

CITY OF SAN DIEGO CALIFORNIA DEPARTMENT INSTRUCTIONS	NUMBER DI 55.27	DEPARTMENT Water Department
SUBJECT FIRE HYDRANT METER PROGRAM (FORMERLY: CONSTRUCTION METER PROGRAM)	PAGE 10 OF 10	EFFECTIVE DATE October 15, 2002
	SUPERSEDES DI 55.27	DATED April 21, 2000

8.5 If damage occurs to Water Department property (i.e. fire hydrant meter, backflow, various appurtenances), the cost of repairs or replacements will be charged to the customer of record (applicant).

**Larry Gardner
Water Department Director**

- Tabs: 1. Fire Hydrant Meter Application
2. Construction & Maintenance Related Activities With No Return To Sewer
3. Notice of Discontinuation of Service

APPENDIX

Administering Division: Customer Support Division

Subject Index: Construction Meters
Fire Hydrant
Fire Hydrant Meter Program
Meters, Floating or Vehicle Mounted
Mobile Meter
Program, Fire Hydrant Meter

Distribution: DI Manual Holders



Application for Fire Hydrant Meter (EXHIBIT A)

(For Office Use Only)

NS REQ	FACH
DATE	BY

METER SHOP (619) 527-7449

Application Date	Requested Install Date:
------------------	-------------------------

Meter Information

Fire Hydrant Location: (Attach Detailed Map//Thomas Bros. Map Location or Construction drawing.) Zip:	T.B.	G.B. (CITY USE)
Specific Use of Water:		
Any Return to Sewer or Storm Drain, if so, explain:		
Estimated Duration of Meter Use:		Check Box If Reclaimed Water

Company Information

Company Name:			
Mailing Address:			
City:	State:	Zip:	Phone: ()
*Business license#		*Contractor license#	
A Copy of the Contractor's license OR Business License is required at the time of meter issuance.			
Name and Title of Billing Agent: (PERSON IN ACCOUNTS PAYABLE)			Phone: ()
Site Contact Name and Title:			Phone: ()
Responsible Party Name:			Title:
Cal ID#			Phone: ()
Signature:		Date:	
Guarantees Payment of all Charges Resulting from the use of this Meter. Insures that employees of this Organization understand the proper use of Fire Hydrant Meter			

Fire Hydrant Meter Removal Request		Requested Removal Date:
Provide Current Meter Location If Different from Above:		
Signature:	Title:	Date:
Phone: ()	Pager: ()	

<input type="checkbox"/> City Meter	<input type="checkbox"/> Private Meter		
Contract Acct #:	Deposit Amount: \$ 936.00	Fees Amount: \$ 62.00	
Meter Serial #	Meter Size: 05	Meter Make and Style: 6-7	
Backflow #	Backflow Size:	Backflow Make and Style:	
Name:	Signature:	Date:	

WATER USES WITHOUT ANTICIPATED CHARGES FOR RETURN TO SEWER

Auto Detailing
Backfilling
Combination Cleaners (Vactors)
Compaction
Concrete Cutters
Construction Trailers
Cross Connection Testing
Dust Control
Flushing Water Mains
Hydro Blasting
Hydro Seeing
Irrigation (for establishing irrigation only; not continuing irrigation)
Mixing Concrete
Mobile Car Washing
Special Events
Street Sweeping
Water Tanks
Water Trucks
Window Washing

Note:

1. If there is any return to sewer or storm drain, then sewer and/or storm drain fees will be charges.

Date

Name of Responsible Party
Company Name and Address
Account Number: _____

Subject: Discontinuation of Fire Hydrant Meter Service

Dear Water Department Customer:

The authorization for use of Fire Hydrant Meter # _____, located at *(Meter Location Address)* ends in 60 days and will be removed on or after *(Date Authorization Expires)*. Extension requests for an additional 90 days must be submitted in writing for consideration 30 days prior to the discontinuation date. If you require an extension, please contact the Water Department, or mail your request for an extension to:

City of San Diego
Water Department
Attention: Meter Services
2797 Caminito Chollas
San Diego, CA 92105-5097

Should you have any questions regarding this matter, please call the Fire Hydrant Hotline at (619) _____ - _____.

Sincerely,

Water Department

APPENDIX C

MATERIALS TYPICALLY ACCEPTED BY CERTIFICATE OF COMPLIANCE

Materials Typically Accepted by Certificate of Compliance

1. Soil amendment
2. Fiber mulch
3. PVC or PE pipe up to 16 inch diameter
4. Stabilizing emulsion
5. Lime
6. Preformed elastomeric joint seal
7. Plain and fabric reinforced elastomeric bearing pads
8. Steel reinforced elastomeric bearing pads
9. Waterstops (Special Condition)
10. Epoxy coated bar reinforcement
11. Plain and reinforcing steel
12. Structural steel
13. Structural timber and lumber
14. Treated timber and lumber
15. Lumber and timber
16. Aluminum pipe and aluminum pipe arch
17. Corrugated steel pipe and corrugated steel pipe arch
18. Structural metal plate pipe arches and pipe arches
19. Perforated steel pipe
20. Aluminum underdrain pipe
21. Aluminum or steel entrance tapers, pipe downdrains, reducers, coupling bands and slip joints
22. Metal target plates
23. Paint (traffic striping)
24. Conductors
25. Painting of electrical equipment
26. Electrical components
27. Engineering fabric
28. Portland Cement
29. PCC admixtures
30. Minor concrete, asphalt
31. Asphalt (oil)
32. Liquid asphalt emulsion
33. Epoxy

APPENDIX D
SAMPLE CITY INVOICE

City of San Diego, Field Engineering Div., 9485 Aero Drive, SD CA 92123		Contractor's Name:	
Project Name:		Contractor's Address:	
Work Order No or Job Order No.			
City Purchase Order No.		Contractor's Phone #:	Invoice No.
Resident Engineer (RE):		Contractor's fax #:	Invoice Date:
RE Phone#:	Fax#:	Contact Name:	Billing Period: (to

Item #	Item Description	Contract Authorization				Previous Totals To Date		This Estimate		Totals to Date	
		Unit	Price	Qty	Extension	%/QTY	Amount	% / QTY	Amount	% / QTY	Amount
1					\$ -		\$ -		\$ -	0.00%	\$ -
2					\$ -		\$ -		\$ -	0.00%	\$ -
3					\$ -		\$ -		\$ -	0.00%	\$ -
4					\$ -		\$ -		\$ -	0.00%	\$ -
5					\$ -		\$ -		\$ -	0.00%	\$ -
6					\$ -		\$ -		\$ -	0.00%	\$ -
7					\$ -		\$ -		\$ -	0.00%	\$ -
8					\$ -		\$ -		\$ -	0.00%	\$ -
9					\$ -		\$ -		\$ -	0.00%	\$ -
10					\$ -		\$ -		\$ -	0.00%	\$ -
11					\$ -		\$ -		\$ -	0.00%	\$ -
12					\$ -		\$ -		\$ -	0.00%	\$ -
13					\$ -		\$ -		\$ -	0.00%	\$ -
14					\$ -		\$ -		\$ -	0.00%	\$ -
15					\$ -		\$ -		\$ -	0.00%	\$ -
16					\$ -		\$ -		\$ -	0.00%	\$ -
17	Field Orders				\$ -		\$ -		\$ -	0.00%	\$ -
18					\$ -		\$ -		\$ -	0.00%	\$ -
	CHANGE ORDER No.				\$ -		\$ -		\$ -	0.00%	\$ -
					\$ -		\$ -		\$ -	0.00%	\$ -
Total Authorized Amount (including approved Change Order)					\$ -		\$ -		\$ -	Total Billed	\$ -

SUMMARY

A. Original Contract Amount	\$ -
B. Approved Change Order #00 Thru #00	\$ -
C. Total Authorized Amount (A+B)	\$ -
D. Total Billed to Date	\$ -
E. Less Total Retention (5% of D)	\$ -
F. Less Total Previous Payments	\$ -
G. Payment Due Less Retention	\$0.00
H. Remaining Authorized Amount	\$0.00

I certify that the materials
have been received by me in
the quality and quantity specified

Resident Engineer

Construction Engineer

Retention and/or Escrow Payment Schedule

Total Retention Required as of this billing (Item E)	\$0.00
Previous Retention Withheld in PO or in Escrow	\$0.00
Add'l Amt to Withhold in PO/Transfer in Escrow:	\$0.00
Amt to Release to Contractor from PO/Escrow:	

Contractor Signature and Date: _____

APPENDIX E
LOCATION MAP

NORTH PARK DIF CR DS

CONSTRUCTION PROJECT
INFORMATION LINE
(619) 533-4207

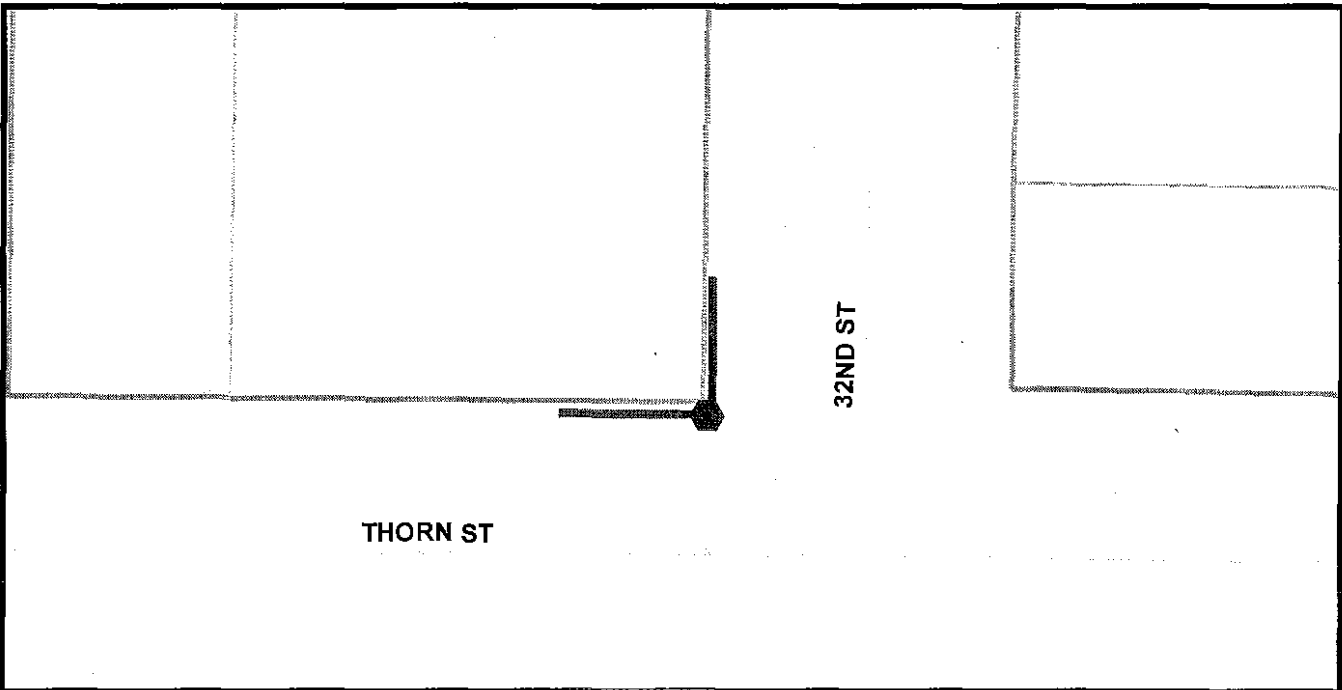
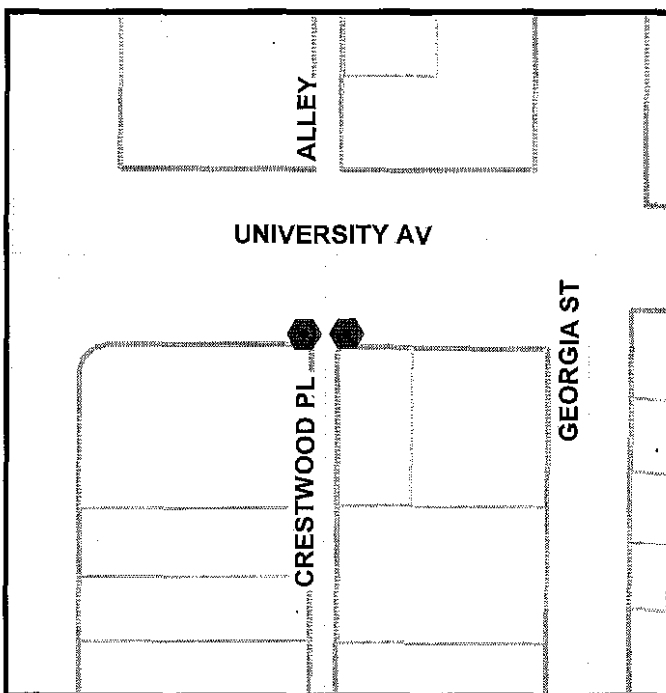
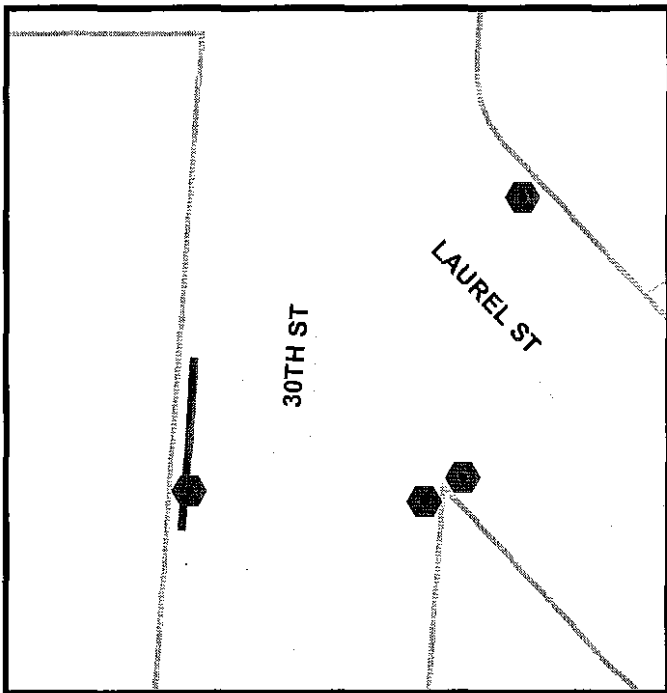
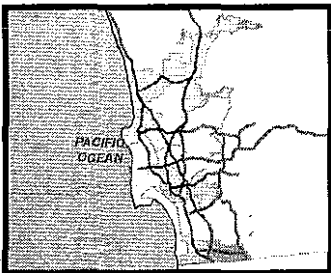

Legend

- Proposed Curb Ramp
- Proposed Sidewalk



THIS MAP/DATA IS PROVIDED WITHOUT WARRANTY OF ANY KIND, EITHER EXPRESS OR IMPLIED, INCLUDING, BUT NOT LIMITED TO, THE IMPLIED WARRANTIES OR MERCHANTABILITY AND FITNESS FOR A PARTICULAR PURPOSE. Note: This product may contain information reproduced with permission granted by RAND McNALLY & COMPANY® to SanGIS. This map is copyrighted by RAND McNALLY & COMPANY®. It is unlawful to copy or reproduce all or any part thereof, whether for personal use or resale, without the prior, written permission of RAND McNALLY & COMPANY.



APPENDIX F
ADJACENT PROJECT

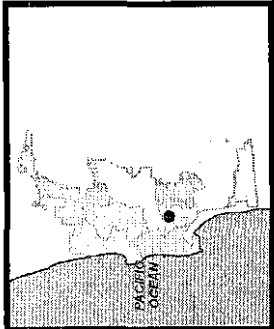



The City of **SAN DIEGO** Public Works

NORTH PARK DIF CR DS



Legend

 Georgia Street Bridge Improvement

 North Park DIF CR DS

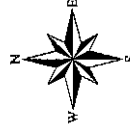

COMMUNITY NAME: NORTH PARK

COUNCIL DISTRICT: 3

SAP ID: B13111

Date: **September 9, 2016**
Group: **106131 North Park DIF CR** Appendix F - Adjacent Project (Rev. Sept. 2016)



THIS MAP/DATA IS PROVIDED WITHOUT WARRANTY OF ANY KIND, EITHER EXPRESS OR IMPLIED, INCLUDING, BUT NOT LIMITED TO, THE IMPLIED WARRANTIES OR MERCHANTABILITY AND FITNESS FOR A PARTICULAR PURPOSE. Note: This product may contain information from the SANDAG Regional Information System which cannot be reproduced without the written permission of SANDAG. This product may contain information reproduce with permission granted by RAND McNALLY & COMPANY® to SanGIS. This map is copyrighted by RAND McNALLY & COMPANY®. It is unlawful to copy or reproduce all or any part thereof, whether for personal use or resale, without the prior, written permission of RAND McNALLY & COMPANY

APPENDIX G
SAMPLE OF PUBLIC NOTICES



CONSTRUCTION NOTICE

PROJECT NAME

Trenching on your street is complete.

What you need to know:

- Pipe installation on your street is complete and construction crews are now installing new pipeline for this project at another location.
- You may see temporary trench plates or trench caps for some time –even after construction activities have concluded on your street.

Street resurfacing:

- Your Streets will be resurfaced once the entire pipeline project is complete.
- Concrete streets will not be resurfaced curb to curb; only the trench will be backfilled.
- Street resurfacing may be delayed due to the City's slurry seal moratorium.

Estimated resurfacing completion on your street:

(Insert Date-Month and Year)

For questions related to this work

Call: (619) 533-4207

Email: engineering@sandiego.gov

Visit: sandiego.gov/CIP



This information is available in alternative formats upon request.



APPENDIX H
ADVANCED METERING INFRASTRUCTURE (AMI) DEVICE PROTECTION

Protecting AMI Devices in Meter Boxes and on Street Lights

The Public Utilities Department (PUD) has begun the installation of the Advanced Metering Infrastructure (AMI) technology as a new tool to enhance water meter reading accuracy and efficiency, customer service and billing, and to be used by individual accounts to better manage the efficient use of water. **All AMI devices shall be protected per Section 5-2, "Protection", of the 2015 Whitebook.**

AMI technology allows water meters to be read electronically rather than through direct visual inspection by PUD field staff. This will assist PUD staff and customers in managing unusual consumption patterns which could indicate leaks or meter tampering on a customer's property.

Three of the main components of an AMI system are the:

- A. Endpoints, see Photo 1:

Photo 1

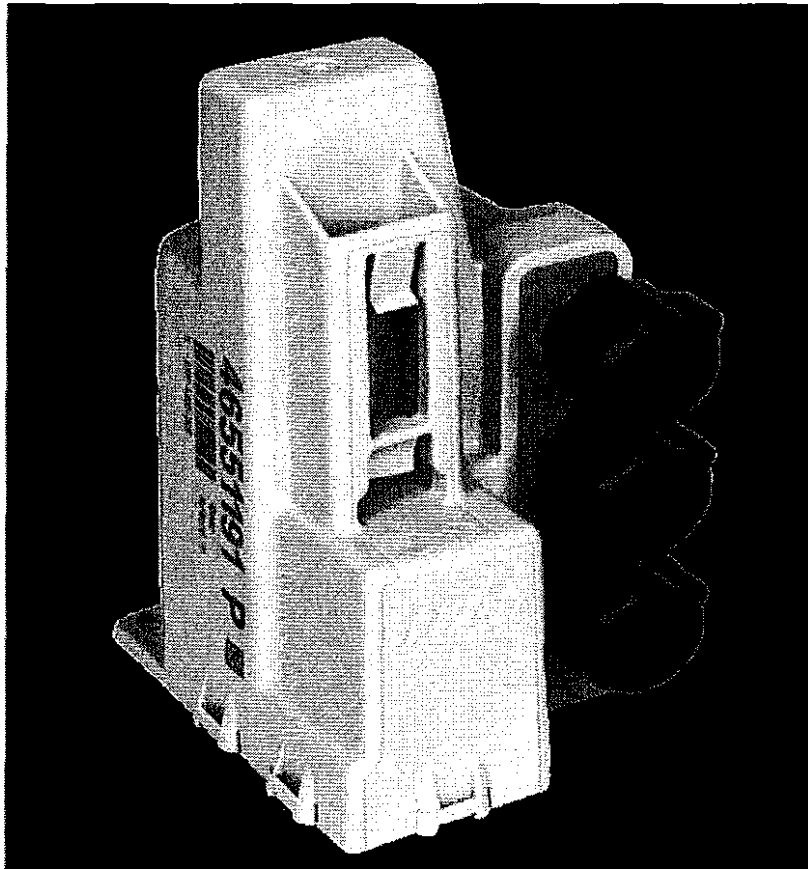

B. AMI Antenna attached to Endpoint (antenna not always required), see Photo 2:

Photo 2

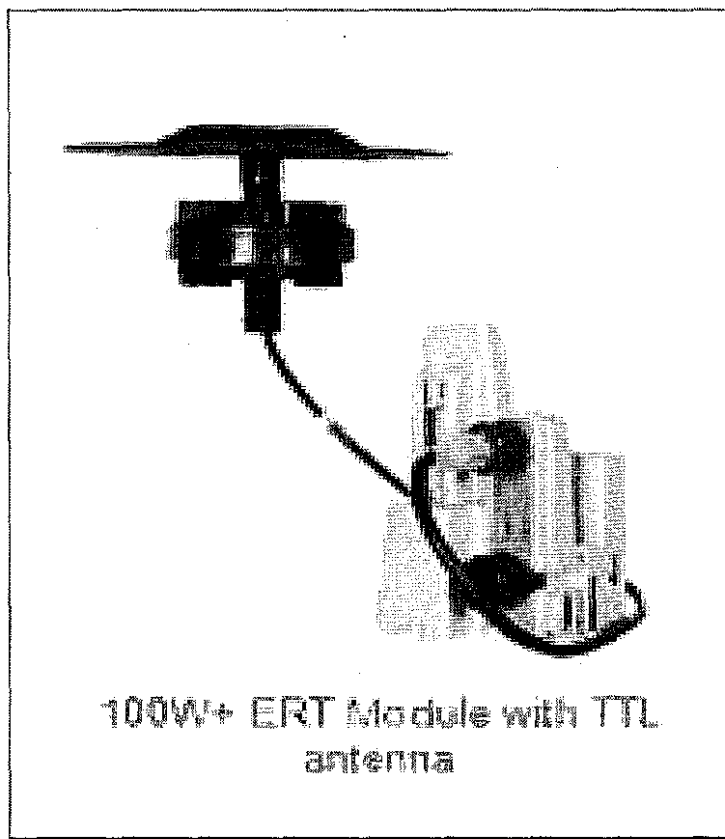

Network Devices, see Photo 3:

Photo 3

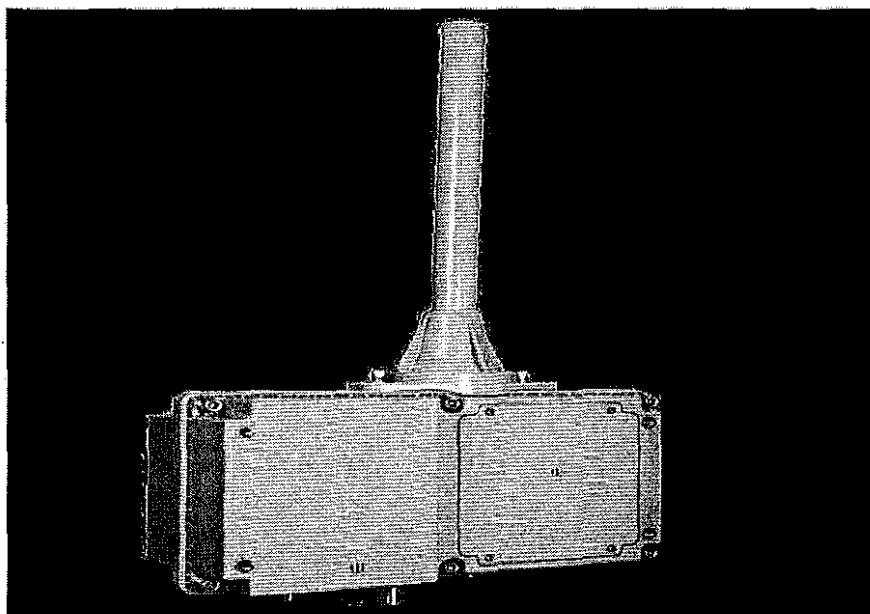

AMI endpoints transmit meter information to the AMI system and will soon be on the vast majority of meters in San Diego. These AMI devices provide interval consumption data to the PUD's Customer Support Division. If these devices are damaged or communication is interrupted, this Division will be alerted of the situation. The endpoints are installed in water meter boxes, coffins, and vaults adjacent to the meter. A separate flat round antenna may also be installed through the meter box lid. This antenna is connected to the endpoint via cable. The following proper installation shall be implemented when removing the lid to avoid damaging the antenna, cable, and/or endpoint. Photo 4 below demonstrates a diagram of the connection:

Photo 4

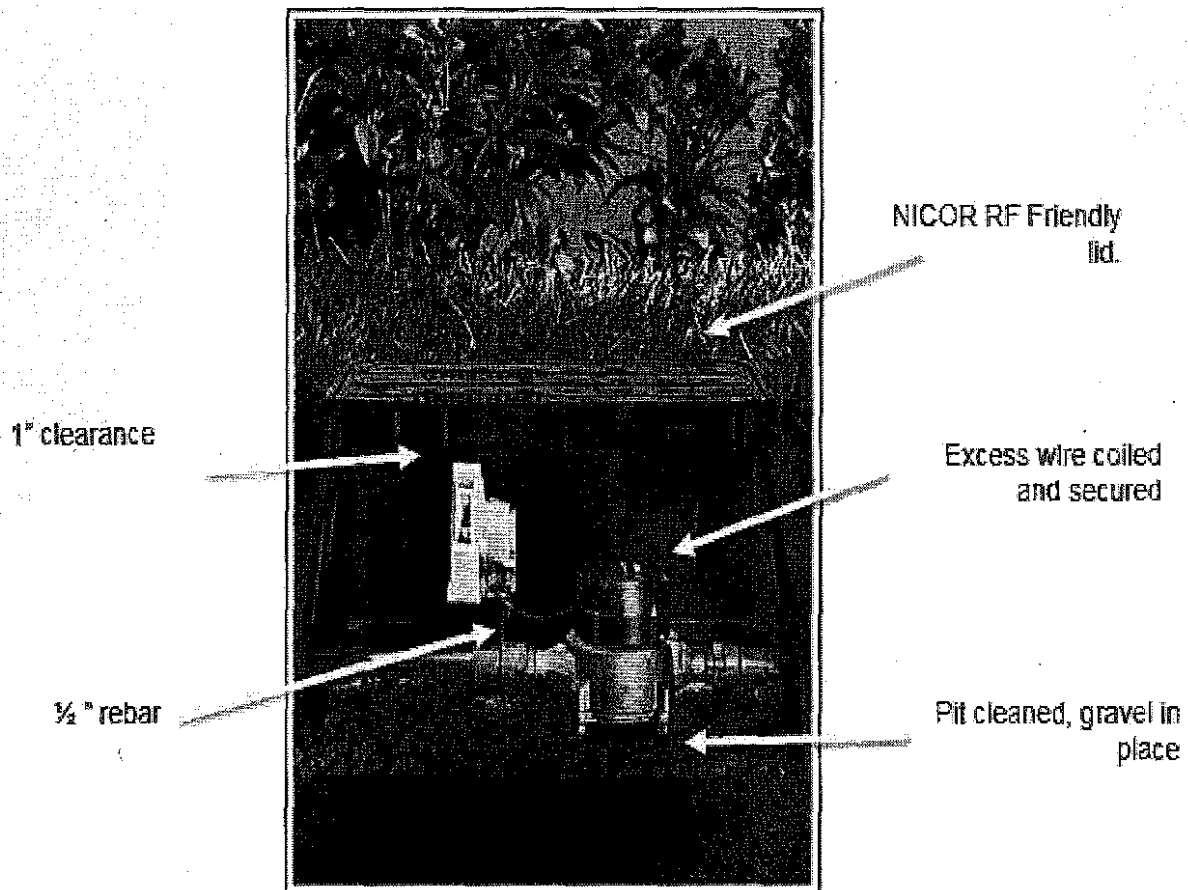

The AMI device ERT/Endpoint/Transmitter shall be positioned and installed as discussed in this Appendix. If the ERT/Endpoint/Transmitter is disturbed, it shall be re-installed and returned to its original installation with the end points pointed upwards as shown below in Photo 5.

The PUD's code compliance staff will issue citations and invoices to you for any damaged AMI devices that are not re-installed as discussed in the Contract Document

Photo 5 below shows a typical installation of an AMI endpoint on a water meter.

Photo 5

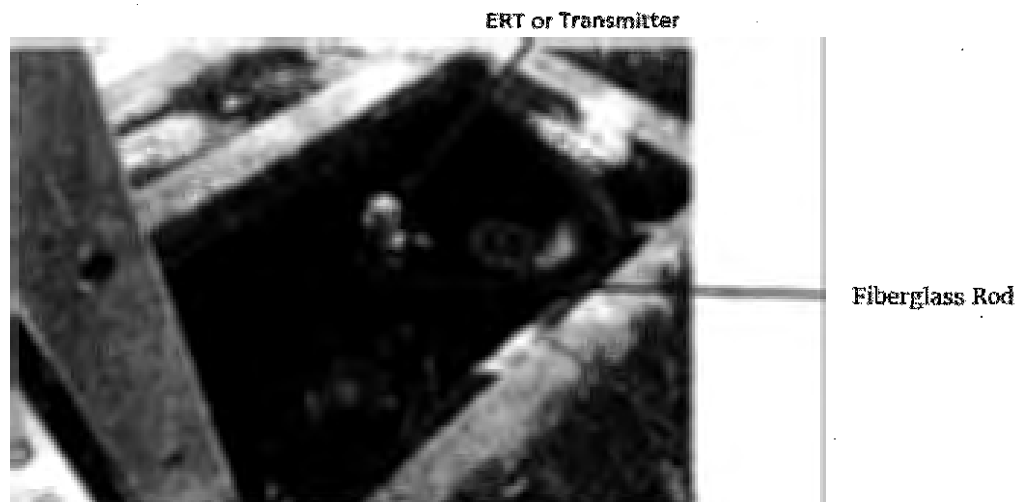
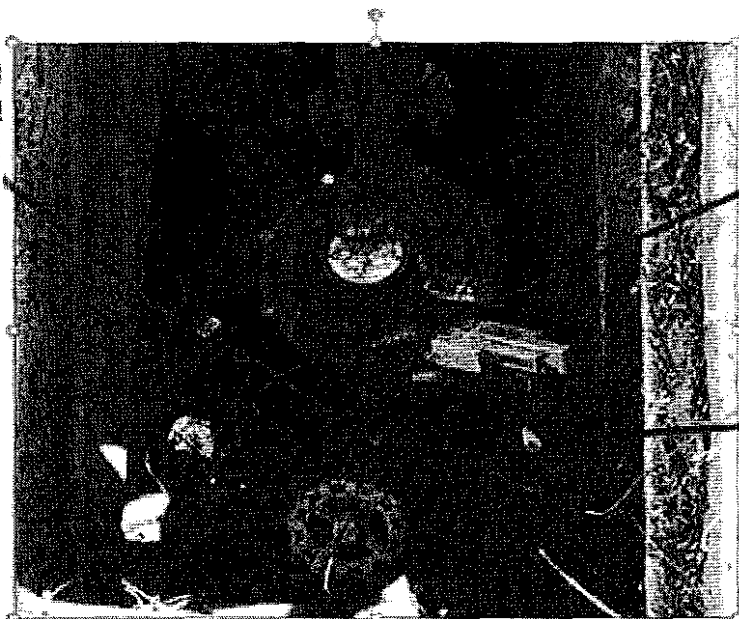

Photo 6 below is an example of disturbance that shall be avoided:

Photo 6

The antenna was drilled into the lid and now it is removed



You are responsible when working in and around meter boxes. If you encounter these endpoints, use proper care and do not disconnect them from the registers on top of the water meter. If the lid has an antenna drilled through, do not change or tamper with the lid and inform the Resident Engineer immediately about the location of that lid. Refer to Photo 7 below:

Photo 7



Another component of the AMI system are the Network Devices. The Network Devices are strategically placed units (mainly on street light poles) that collect interval meter reading data from multiple meters for transmission to the Department Control Computer. **If you come across any of these devices on street lights that will be removed or replaced (refer to Photos 8 and 9 below), notify AMI Project Manager Arwa Sayed at (619) 362-0121 immediately.**

Photo 8 shows an installed network device on a street light. On the back of each Network Device is a sticker with contact information. See Photo 9. **Call PUD Water Emergency Repairs at 619-515-3525 if your work will impact these street lights.** These are assets that belong to the City of San Diego and you shall be responsible for any costs of disruption of this network.

Photo 8



Network Device

Photo 9



If you encounter any bad installations, disconnected/broken/buried endpoints, or inadvertently damage any AMI devices or cables, notify the Resident Engineer immediately. The Resident Engineer will then immediately contact the AMI Project Manager, Arwa Sayed, at (619) 362-0121.

APPENDIX I
PRIVATE PROPERTY PERMIT

THE CITY OF SAN DIEGO

PERMIT TO DO WORK ON PRIVATE PROPERTY

WBS #: B-13111

Date: June 27, 2016

Property Owner(s): Phillips Investment Corp of California

Property Owner(s) Address: 3843 Park Blvd San Diego, CA 92103

Address and legal description of where the work is to be done: Address: 1825 University Avenue San Diego, CA 92103

Assessor's Parcel Number: 452-201-22-00

Project Title: Group Job 131 North Park Project

Description of the work to be done: The proposed project includes installation of curb ramps at the intersections of University Ave. & Crestwood Pl., Laurel St. & 30th St., and Thorn St. and 32nd St. The project is located in the North Park community of Council District 3. Due to the installation of new curb ramps at the intersection of University Ave. and Crestwood Pl., a portion of the existing sidewalk on the property located at 1825 University Avenue will need to be removed and replaced with new sidewalk, steps and rails by the City in order to match the new elevations.

THE UNDERSIGNED PROPERTY OWNERS DO HEREBY GRANT to the City of San Diego, its agents and representatives, on behalf of said property owner(s) and their successors and assigns, and in consideration of the benefits to accrue to the subject real property, permission to enter upon the subject real property for the purpose of doing the work stated above, in accordance with the standards of the City of San Diego and the following terms and conditions:

- 1) the undersigned Property Owner(s) shall provide the City of San Diego, its agents and representatives, reasonable access to the above-described property to perform the necessary work; and
- 2) the permission herein granted shall terminate upon the date of completion of said work, as completion date is determined by the City of San Diego; and
- 3) in accord with project specifications, any private improvements damaged or disturbed during completion of the above-stated work, will be replaced in kind, and Property Owner(s) shall not be held liable for any damage to equipment or injury to personnel of the City of San Diego, its agents or employees, incurred in performance of said work.

PHILLIPS INVESTMENT CORPORATION OF CALIF. by Robert W. Phillips OR OTHER OFFICER
 Property Owner Date 7/28/16 President

This Permit is Requested, and Terms Approved, for the City by:

Name	Title	Department	Date
------	-------	------------	------

Handwritten signature and date: RWD 7/28/16

THE CITY OF SAN DIEGO

PERMIT TO DO WORK ON PRIVATE PROPERTY

WBS #: B-13111

Date: June 27, 2016

Property Owner(s): Saad & Wasan Ewdish

Property Owner(s) Address: 3302 32nd Street San Diego, CA 92104

Address and legal description of where the work is to be done: Address: 3302 32nd Street San Diego, CA 92104

Assessor's Parcel Number: 453-502-15-00

Project Title: Group Job 13I North Park DIF DS Project

Description of the work to be done: The proposed project includes installation of curb ramps at the intersections of University Ave. & Crestwood Pl., Laurel St. & 30th St., and Thorn St. and 32nd St. The project is located in the North Park community of Council District 3. Due to the relocation of existing storm drain and installation of a new curb ramp at the intersection of Thorn St. and 32nd St., a portion of the existing asphalt on the property located at 3302 32nd St will need to be removed and replaced by the City in order to match the new elevations.

THE UNDERSIGNED PROPERTY OWNERS DO HEREBY GRANT to the City of San Diego, its agents and representatives, on behalf of said property owner(s) and their successors and assigns, and in consideration of the benefits to accrue to the subject real property, permission to enter upon the subject real property for the purpose of doing the work stated above, in accordance with the standards of the City of San Diego and the following terms and conditions:

- 1) the undersigned Property Owner(s) shall provide the City of San Diego, its agents and representatives, reasonable access to the above-described property to perform the necessary work; and
- 2) the permission herein granted shall terminate upon the date of completion of said work, as completion date is determined by the City of San Diego; and
- 3) in accord with project specifications, any private improvements damaged or disturbed during completion of the above-stated work, will be replaced in kind, and Property Owner(s) shall not be held liable for any damage to equipment or injury to personnel of the City of San Diego, its agents or employees, incurred in performance of said work.

SAAD EWDISH 6/27/2016
 Property Owner Date

 This Permit is Requested, and Terms Approved, for the City by:

_____	_____	_____	_____
Name	Title	Department	Date

ATTACHMENT F
INTENTIONALLY LEFT BLANK

ATTACHMENT G
CONTRACT AGREEMENT

CONTRACT AGREEMENT

CONSTRUCTION CONTRACT

This contract is made and entered into between THE CITY OF SAN DIEGO, a municipal corporation, herein called "City", and Crest Equipment Inc., herein called "Contractor" for construction of **Group Job 13I North Park DIF CR; Bid No. L-17-1524-DBB-1**; in the amount of One Hundred Twenty-Five Thousand Two Hundred Thirty-Five Dollars (\$125,235.00), which is comprised of the Base Bid.

IN CONSIDERATION of the payments to be made hereunder and the mutual undertakings of the parties hereto, City and Contractor agree as follows:

1. The following are incorporated into this contract as though fully set forth herein:
 - (a) The attached Faithful Performance and Payment Bonds.
 - (b) The attached Proposal included in the Bid documents by the Contractor.
 - (c) Reference Standards listed in the Instruction to Bidders and the Supplementary Special Provisions (SSP).
 - (d) That certain documents entitled **Group Job 13I North Park DIF CR**, on file in the office of the Public Works Department as Document No. **B-13111**, as well as all matters referenced therein.
2. The Contractor shall perform and be bound by all the terms and conditions of this contract and in strict conformity therewith shall perform and complete in a good and workmanlike manner **Group Job 13I North Park DIF CR**, Bid Number **L-17-1524-DBB-1**, San Diego, California.
3. For such performances, the City shall pay to Contractor the amounts set forth at the times and in the manner and with such additions or deductions as are provided for in this contract, and the Contractor shall accept such payment in full satisfaction of all claims incident to such performances.
4. No claim or suit whatsoever shall be made or brought by Contractor against any officer, agent, or employee of the City for or on account of anything done or omitted to be done in connection with this contract, nor shall any such officer, agent, or employee be liable hereunder.
5. This contract is effective as of the date that the Mayor or designee signs the agreement.

CONTRACT AGREEMENT (continued)

IN WITNESS WHEREOF, this Agreement is signed by the City of San Diego, acting by and through its Mayor or designee, pursuant to _____ Municipal Code 22.3103 authorizing such execution.

THE CITY OF SAN DIEGO

APPROVED AS TO FORM

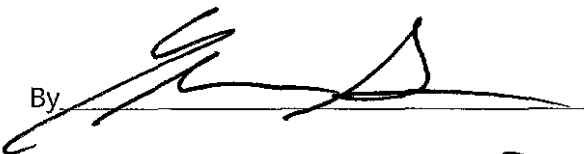
By 

Mara W. Elliot, City Attorney
By 
Deputy City Attorney

Print Name: Clementina Giordano
Clementina Giordano, Contract Specialist
Public Works Contracting

Print Name: Pedro De Caro, Jr.
Deputy City Attorney

Date: 1/30/17

Date: 2/8/17

CONTRACTOR

By 

Print Name: Wendy Belio

Title: Pres

Date: 12-1-16

City of San Diego License No.: B2003025367

State Contractor's License No.: 892791

DEPARTMENT OF INDUSTRIAL RELATIONS (DIR) REGISTRATION NUMBER: 1000005405

CERTIFICATIONS AND FORMS

The Bidder, by submitting its electronic bid, agrees to and certifies under penalty of perjury under the laws of the State of California, that the certifications, forms and affidavits submitted as part of this bid are true and correct.

Bidder's General Information

To the City of San Diego:

Pursuant to "Notice Inviting Bids", specifications, and requirements on file with the City Clerk, and subject to all provisions of the Charter and Ordinances of the City of San Diego and applicable laws and regulations of the United States and the State of California, the undersigned hereby proposes to furnish to the City of San Diego, complete at the prices stated herein, the items or services hereinafter mentioned. The undersigned further warrants that this bid is not made in the interest of, or on behalf of, any undisclosed person, partnership, company, association, organization, or corporation; that the bid is genuine and not collusive or sham; that the bidder has not directly or indirectly induced or solicited any other bidder to put in a false or sham bid, and has not directly or indirectly colluded, conspired, connived, or agreed with any bidder or anyone else to put in a sham bid, or that anyone shall refrain from bidding; that the bidder has not in any manner, directly or indirectly, sought by agreement, communication, or conference with anyone to fix the bid price of the bidder or any other bidder, or to fix any overhead, profit, or cost element of the bid price, or of that of any other bidder, or to secure any advantage against the public body awarding the contract of anyone interested in the proposed contract; that all statements contained in the bid are true; and, further, that the bidder has not, directly or indirectly, submitted his or her bid price or any breakdown thereof, or the contents thereof, or divulged information or data relative thereto, or paid, and will not pay, any fee to any corporation, partnership, company, association, organization, bid depository, or to any member or agent thereof to effectuate a collusive or sham bid.

The undersigned bidder(s) further warrants that bidder(s) has thoroughly examined and understands the entire Contract Documents (plans and specifications) and the Bidding Documents therefore, and that by submitting said Bidding Documents as its bid proposal, bidder(s) acknowledges and is bound by the entire Contract Documents, including any addenda issued thereto, as such Contract Documents incorporated by reference in the Bidding Documents.

**NON-COLLUSION AFFIDAVIT TO BE EXECUTED BY BIDDER AND SUBMITTED
WITH BID UNDER 23 UNITED STATES CODE 112 AND PUBLIC CONTRACT CODE
7106**

State of California

County of San Diego

The bidder, being first duly sworn, deposes and says that he or she is authorized by the party making the foregoing bid that the bid is not made in the interest of, or on behalf of, any undisclosed person, partnership, company, association, organization, or corporation; that the bid is genuine and not collusive or sham; that the bidder has not directly or indirectly induced or solicited any other bidder to put in a false or sham bid, and has not directly or indirectly colluded, conspired, connived, or agreed with any bidder or anyone else to put in a sham bid, or that anyone shall refrain from bidding; that the bidder has not in any manner, directly or indirectly, sought by agreement, communication, or conference with anyone to fix the bid price of the bidder or any other bidder, or to fix any overhead, profit, or cost element of the bid price, or of that of any other bidder, or to secure any advantage against the public body awarding the contract of anyone interested in the proposed contract; that all statements contained in the bid are true; and further, that the bidder has not, directly or indirectly, submitted his or her bid price or any breakdown thereof, or the contents thereof, or divulged information or data relative thereto, or paid, and will not pay, any fee to any corporation, partnership, company association, organization, bid depository, or to any member or agent thereof to effectuate a collusive or sham bid.

CONTRACTOR CERTIFICATION

DRUG-FREE WORKPLACE

I hereby certify that I am familiar with the requirements of San Diego City Council Policy No. 100-17 regarding Drug-Free Workplace as outlined in the WHITEBOOK, Section 7-13.3, "Drug-Free Workplace", of the project specifications, and that;

This company has in place a drug-free workplace program that complies with said policy. I further certify that each subcontract agreement for this project contains language which indicates the subcontractor's agreement to abide by the provisions of subdivisions a) through c) of the policy as outlined.

CONTRACTOR CERTIFICATION

CONTRACTOR STANDARDS AND PLEDGE OF COMPLIANCE

I declare under penalty of perjury that I am authorized to make this certification on behalf of the company submitting this bid/proposal, that as Contractor, I am familiar with the requirements of City of San Diego Municipal Code § 22.3004 regarding Contractor Standards as outlined in the WHITEBOOK, Section 7-13.4, ("Contractor Standards and Pledge of Compliance"), of the project specifications, and that Contractor has complied with those requirements.

I further certify that each of the Contractor's subcontractors whose subcontracts are greater than \$50,000 in value has completed a Pledge of Compliance attesting under penalty of perjury of having complied with City of San Diego Municipal Code § 22.3004.

AFFIDAVIT OF DISPOSAL

(To be submitted upon completion of Construction pursuant to the contracts Certificate of Completion)

WHEREAS, on the _____ DAY OF _____, 2____ the undersigned entered into and executed a contract with the City of San Diego, a municipal corporation, for:

(Name of Project or Task)

as particularly described in said contract and identified as Bid No. _____; SAP No. (WBS/IO/CC) _____; and **WHEREAS**, the specification of said contract requires the Contractor to affirm that "all brush, trash, debris, and surplus materials resulting from this project have been disposed of in a legal manner"; and **WHEREAS**, said contract has been completed and all surplus materials disposed of:

NOW, THEREFORE, in consideration of the final payment by the City of San Diego to said Contractor under the terms of said contract, the undersigned Contractor, does hereby affirm that all surplus materials as described in said contract have been disposed of at the following location(s)

and that they have been disposed of according to all applicable laws and regulations.

Dated this _____ DAY OF _____, _____.

Contractor

by

ATTEST:

State of _____ County of _____

On this _____ DAY OF _____, 2____, before the undersigned, a Notary Public in and for said County and State, duly commissioned and sworn, personally appeared _____ known to me to be the _____ Contractor named in the foregoing Release, and whose name is subscribed thereto, and acknowledged to me that said Contractor executed the said Release.

Notary Public in and for said County and State

ELECTRONICALLY SUBMITTED FORMS

THE FOLLOWING FORMS MUST BE SUBMITTED IN PDF FORMAT WITH BID SUBMISSION

The following forms are to be completed by the bidder and submitted (uploaded) electronically with the bid in PlanetBids.

A. CONTRACTOR'S CERTIFICATION OF PENDING ACTIONS

B. EQUAL BENEFITS ORDINANCE - CERTIFICATION OF COMPLIANCE

Bids will not be accepted until ALL forms are submitted as part of the bid submittal

EQUAL BENEFITS ORDINANCE

CERTIFICATION OF COMPLIANCE



For additional information, contact:

CITY OF SAN DIEGO

EQUAL BENEFITS PROGRAM

202 C Street, MS 9A, San Diego, CA 92101

COMPANY INFORMATION	
Company Name: <u>Crest Equipment Inc</u>	Contact Name: <u>Wendy Belio</u>
Company Address: <u>161 Scottford Dr</u>	Contact Phone: <u>6194448041</u>
<u>91 caion CA 92021</u>	Contact Email: <u>belioes@csiohca.com.net</u>

CONTRACT INFORMATION	
Contract Title: <u>Group Job 131 North Park DIF</u>	Start Date:
Contract Number (if no number, state location):	End Date:

SUMMARY OF EQUAL BENEFITS ORDINANCE REQUIREMENTS

The Equal Benefits Ordinance [EBO] requires the City to enter into contracts only with contractors who certify they will provide and maintain equal benefits as defined in SDMC §22.4302 for the duration of the contract. To comply:

- Contractor shall offer equal benefits to employees with spouses and employees with domestic partners.
 - Benefits include health, dental, vision insurance; pension/401(k) plans; bereavement, family, parental leave; discounts, child care; travel/relocation expenses; employee assistance programs; credit union membership; or any other benefit.
 - Any benefit not offer an employee with a spouse, is not required to be offered to an employee with a domestic partner.
- Contractor shall post notice of firm's equal benefits policy in the workplace and notify employees at time of hire and during open enrollment periods.
- Contractor shall allow City access to records, when requested, to confirm compliance with EBO requirements.
- Contractor shall submit *EBO Certification of Compliance*, signed under penalty of perjury, prior to award of contract.

NOTE: This summary is provided for convenience. Full text of the EBO and Rules Implementing the EBO are available at www.sandiego.gov/administration.

CONTRACTOR EQUAL BENEFITS ORDINANCE CERTIFICATION

Please indicate your firm's compliance status with the EBO. The City may request supporting documentation.

- I affirm compliance with the EBO because my firm (contractor must select one reason):
- Provides equal benefits to spouses and domestic partners.
 - Provides no benefits to spouses or domestic partners.
 - Has no employees.
 - Has collective bargaining agreement(s) in place prior to January 1, 2011, that has not been renewed or expired.
- I request the City's approval to pay affected employees a cash equivalent in lieu of equal benefits and verify my firm made a reasonable effort but is not able to provide equal benefits upon contract award. I agree to notify employees of the availability of a cash equivalent for benefits available to spouses but not domestic partners and to continue to make every reasonable effort to extend all available benefits to domestic partners.

It is unlawful for any contractor to knowingly submit any false information to the City regarding equal benefits or cash equivalent associated with the execution, award, amendment, or administration of any contract. [San Diego Municipal Code §22.4307(a)] Under penalty of perjury under laws of the State of California, I certify the above information is true and correct. I further certify that my firm understands the requirements of the Equal Benefits Ordinance and will provide and maintain equal benefits for the duration of the contract or pay a cash equivalent if authorized by the City.

<u>Wendy Belio</u>	<u>Wendy Belio</u>	<u>11-22-14</u>
Name/Title of Signatory	Signature	Date

FOR OFFICIAL CITY USE ONLY			
Receipt Date:	EBO Analyst:	<input type="checkbox"/> Approved	<input type="checkbox"/> Not Approved - Reason:

(Rev 02/15/2011)

CONTRACTOR'S CERTIFICATION OF PENDING ACTIONS

As part of its bid or proposal (Non-Price Proposal in the case of Design-Build contracts), the Bidder shall provide to the City a list of all instances within the past 10 years where a complaint was filed or pending against the Bidder in a legal or administrative proceeding alleging that Bidder discriminated against its employees, subcontractors, vendors or suppliers, and a description of the status or resolution of that complaint, including any remedial action taken.

CHECK ONE BOX ONLY.

- The undersigned certifies that within the past 10 years the Bidder has NOT been the subject of a complaint or pending action in a legal administrative proceeding alleging that Bidder discriminated against its employees, subcontractors, vendors or suppliers.

- The undersigned certifies that within the past 10 years the Bidder has been the subject of a complaint or pending action in a legal administrative proceeding alleging that Bidder discriminated against its employees, subcontractors, vendors or suppliers. A description of the status or resolution of that complaint, including any remedial action taken and the applicable dates is as follows:

DATE OF CLAIM	LOCATION	DESCRIPTION OF CLAIM	LITIGATION (Y/N)	STATUS	RESOLUTION/REMEDIAL ACTION TAKEN

Contractor Name: Crest Equipment Inc

Certified By: Wendy Bulio Title: pres

Name
Wendy Bulio Date: 11-22-16

Signature

USE ADDITIONAL FORMS AS NECESSARY

BID BOND

**See Instructions to Bidders, Bidder Guarantee of Good Faith
(Bid Security)**

KNOW ALL MEN BY THESE PRESENTS,

That Crest Equipment, Inc. as Principal, and
SureTec Insurance Company as Surety, are

held and firmly bound unto The City of San Diego hereinafter called "OWNER," in the sum of 10% OF THE TOTAL BID AMOUNT for the payment of which sum, well and truly to be made, we bind ourselves, our heirs, executors, administrators, successors, and assigns, jointly and severally, firmly by these presents.

WHEREAS, said Principal has submitted a Bid to said OWNER to perform the WORK required under the bidding schedule(s) of the OWNER's Contract Documents entitled

Group Job 131 North Park DIF CR

NOW THEREFORE, if said Principal is awarded a contract by said OWNER and, within the time and in the manner required in the "Notice Inviting Bids" enters into a written Agreement on the form of agreement bound with said Contract Documents, furnishes the required certificates of insurance, and furnishes the required Performance Bond and Payment Bond, then this obligation shall be null and void, otherwise it shall remain in full force and effect. In the event suit is brought upon this bond by said OWNER and OWNER prevails, said Surety shall pay all costs incurred by said OWNER in such suit, including a reasonable attorney's fee to be fixed by the court.

SIGNED AND SEALED, this 21st day of November, 2016

Crest Equipment, Inc. (SEAL)

SureTec Insurance Company (SEAL)

(Principal)

(Surety)

By Wend Zelio

By: Dana Michaelis
Dana Michaelis
Attorney-in-Fact

(Signature)

(Signature)

(SEAL AND NOTARIAL ACKNOWLEDGEMENT OF SURETY)

CALIFORNIA ALL-PURPOSE ACKNOWLEDGMENT

A notary public or other officer completing this certificate verifies only the identity of the individual who signed the document to which this certificate is attached, and not the truthfulness, accuracy, or validity of that document.

STATE OF CALIFORNIA

County of San Diego }

On November 21, 2016 before me, Pam Davis, Notary Public,
Date Insert Name of Notary exactly as it appears on the official seal

personally appeared Dana Michaelis
Name(s) of Signer(s)

who proved to me on the basis of satisfactory evidence to be the person(s) whose name(s) is/are subscribed to the within instrument and acknowledged to me that he/she/they executed the same in his/her/their authorized capacity(ies), and that by his/her/their signature(s) on the instrument the person(s), or the entity upon behalf of which the person(s) acted, executed the instrument.

I certify under PENALTY OF PERJURY under the laws of the State of California that the foregoing paragraph is true and correct.

Witness my hand and official seal.

Signature *Pam Davis*
Signature of Notary Public Pam Davis

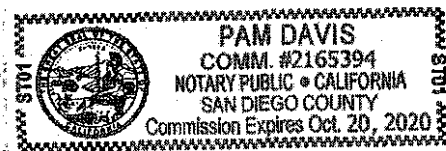

Place Notary Seal Above

OPTIONAL

Though the information below is not required by law, it may prove valuable to persons relying on the document and could prevent fraudulent removal and reattachment of the form to another document.

Description of Attached Document

Title or Type of Document: _____

Document Date: _____ Number of Pages: _____

Signer(s) Other Than Named Above: _____

Capacity(ies) Claimed by Signer(s)

Signer's Name: _____

- Individual
- Corporate Officer — Title(s): _____
- Partner Limited General
- Attorney in Fact
- Trustee
- Guardian or Conservator
- Other: _____

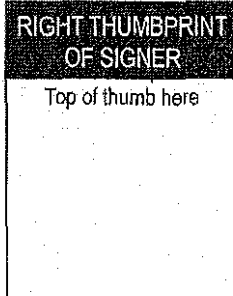

Signer is Representing:

Signer's Name: _____

- Individual
- Corporate Officer — Title(s): _____
- Partner Limited General
- Attorney in Fact
- Trustee
- Guardian or Conservator
- Other: _____

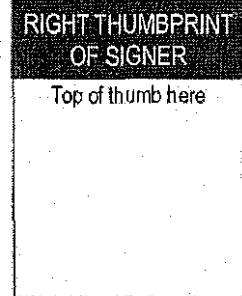

Signer is Representing:

SureTec Insurance Company

LIMITED POWER OF ATTORNEY

Know All Men by These Presents, That SURETEC INSURANCE COMPANY (the "Company"), a corporation duly organized and existing under the laws of the State of Texas, and having its principal office in Houston, Harris County, Texas, does by these presents make, constitute and appoint

Anne Wright, Cyndi Bellman, Dana Michaelis

its true and lawful Attorney-in-fact, with full power and authority hereby conferred in its name, place and stead, to execute, acknowledge and deliver any and all bonds, recognizances, undertakings or other instruments or contracts of suretyship to include waivers to the conditions of contracts and consents of surety for:

Five Million and 00/100 Dollars (\$5,000,000.00)

and to bind the Company thereby as fully and to the same extent as if such bond were signed by the President, sealed with the corporate seal of the Company and duly attested by its Secretary, hereby ratifying and confirming all that the said Attorney-in-Fact may do in the premises. Said appointment shall continue in force until 05/18/2017 and is made under and by authority of the following resolutions of the Board of Directors of the SureTec Insurance Company:

Be it Resolved, that the President, any Vice-President, any Assistant Vice-President, any Secretary or any Assistant Secretary shall be and is hereby vested with full power and authority to appoint any one or more suitable persons as Attorney(s)-in-Fact to represent and act for and on behalf of the Company subject to the following provisions:

Attorney-in-Fact may be given full power and authority for and in the name of and of behalf of the Company, to execute, acknowledge and deliver, any and all bonds, recognizances, contracts, agreements or indemnity and other conditional or obligatory undertakings and any and all notices and documents canceling or terminating the Company's liability thereunder, and any such instruments so executed by any such Attorney-in-Fact shall be binding upon the Company as if signed by the President and sealed and effected by the Corporate Secretary.

Be it Resolved, that the signature of any authorized officer and seal of the Company heretofore or hereafter affixed to any power of attorney or any certificate relating thereto by facsimile, and any power of attorney or certificate bearing facsimile signature or facsimile seal shall be valid and binding upon the Company with respect to any bond or undertaking to which it is attached. *(Adopted at a meeting held on 20th of April, 1999.)*

In Witness Whereof, SURETEC INSURANCE COMPANY has caused these presents to be signed by its President, and its corporate seal to be hereto affixed this 21st day of March, A.D. 2013.

SURETEC INSURANCE COMPANY

By: 
John Knox Jr., President



State of Texas ss:
County of Harris

On this 21st day of March, A.D. 2013 before me personally came John Knox Jr., to me known, who, being by me duly sworn, did depose and say, that he resides in Houston, Texas, that he is President of SURETEC INSURANCE COMPANY, the company described in and which executed the above instrument; that he knows the seal of said Company; that the seal affixed to said instrument is such corporate seal; that it was so affixed by order of the Board of Directors of said Company; and that he signed his name thereto by like order.

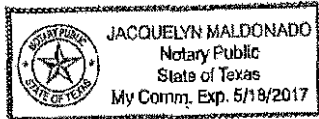

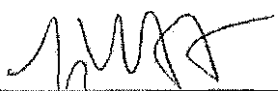
Jacquelyn Maldonado, Notary Public
My commission expires May 18, 2017

I, M. Brent Beaty, Assistant Secretary of SURETEC INSURANCE COMPANY, do hereby certify that the above and foregoing is a true and correct copy of a Power of Attorney, executed by said Company, which is still in full force and effect; and furthermore, the resolutions of the Board of Directors, set out in the Power of Attorney are in full force and effect.

Given under my hand and the seal of said Company at Houston, Texas this 21st day of November, 2016, A.D.

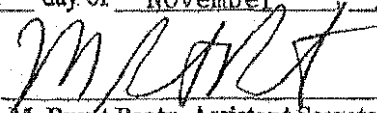
M. Brent Beaty, Assistant Secretary

Any instrument issued in excess of the penalty stated above is totally void and without any validity.
For verification of the authority of this power you may call (713) 812-0800 any business day between 8:00 am and 5:00 pm CST.

Bid Results for Project Group Job 131 North Park DIF (L-17-1524-DBB-2)
 Issued on 10/18/2016
 Bid Due on November 22, 2016 1:30 PM (Pacific)
 Exported on 11/22/2016

Vendor ID	Company Name	Address	City	State	Zip Code	Country	Contact	Phone	Fax	Email	Vendor Type
287015	Crest Equipment Inc	161 Scottford Dr	El Cajon		92021	United States	Wendi Bello	619-444-5061	619-447-6540	Bello@sbcglobal.net	CAU,FEM, ELBE,PQU AL,MBE,S DB,WBE, WOSB,Local

Responsee	Responsee Title	Responsee Phone	Responsee Email
Wendi Bello	President	619-444-5061	bello@sbcglobal.net

Attachments		
File Title	File Name	File Type
Group CCPA and Bid Bond	Group CCPA and Bid Bond.pdf	General Attachments
Group 131 EBO	Group 131 EBO.pdf	General Attachments

Line Items									
Item Num	Section	Item Code	Description	Unit of Measur	Quantity	Unit Price	Line Total	Comment	
1	Main Bid	524125	Bonds (Payment and Performance)	LS	1	\$3,400.00	\$3,400.00		
2	Main Bid	238990	Video Recording of Existing Conditions	LS	1	\$250.00	\$250.00		
3	Main Bid	541330	Traffic Control Design (Working Drawings)	LS	1	\$1,250.00	\$1,250.00		
4	Main Bid	237310	Traffic Control	LS	1	\$4,500.00	\$4,500.00		
5	Main Bid		Field Orders (EOC Type II)	AL	1	\$12,500.00	\$12,500.00		
6	Main Bid	238910	Clearing and Grubbing	LS	1	\$3,800.00	\$3,800.00		
7	Main Bid	237310	Excavate and Fill (Unclassified)	CY	52	\$62.00	\$3,224.00		
8	Main Bid	237310	Adjust Pull Box To Grade	EA	1	\$500.00	\$500.00		
9	Main Bid	237310	Adjust Parking Meter To Grade	EA	1	\$1,500.00	\$1,500.00		
10	Main Bid	237310	Cold Milling Asphalt Concrete Pavement (1-1/2 Inch)	SF	2700	\$1.50	\$4,050.00		
11	Main Bid	237310	Asphalt Concrete (1-1/2 Inch)	TON	24	\$300.00	\$7,200.00		
12	Main Bid	237310	Miscellaneous Asphalt Patching	TON	4	\$250.00	\$1,000.00		
13	Main Bid	237110	Curb Inlet (Type B2)	EA	1	\$5,500.00	\$5,500.00		
14	Main Bid	237110	Storm Drain Clean Out (Type A)	EA	1	\$4,800.00	\$4,800.00		
15	Main Bid	237310	Concrete Steps and Handrails at the Following Property: 1825 University Avenue	LS	1	\$5,100.00	\$5,100.00		
16	Main Bid	237310	Curb and Gutter (6 Inch Curb, Type G)	LF	50	\$48.00	\$2,400.00		
17	Main Bid	237310	Curb and Gutter (up to 10 Inch Curb, Type G)	LF	30	\$52.00	\$1,560.00		
18	Main Bid	237310	Curb and Gutter (2 Inch Curb, Type G)	LF	36	\$42.00	\$1,512.00		
19	Main Bid	237310	Commercial Concrete Driveway	SF	460	\$9.75	\$4,485.00		
20	Main Bid	237310	Remove and Replace Existing Sidewalk	SF	677	\$6.50	\$4,400.50		
21	Main Bid	237310	Contractor Date Stamps and Impressions	EA	2	\$250.00	\$500.00		
22	Main Bid	237310	Alley Apron	SF	230	\$11.25	\$2,587.50		
23	Main Bid	237310	Curb Ramp Modified (Type A, Per 38156-04-D) with Replaceable Detectable Warning Tiles at Laurel Street and 30th Street Intersection	EA	2	\$4,800.00	\$9,600.00		
24	Main Bid	237310	Curb Ramp Modified (Type D, Per 38156-03-D) with Replaceable Detectable Warning Tiles	EA	2	\$3,600.00	\$7,200.00		

