

City of San Diego

CONTRACTOR'S NAME: TC Construction

ADDRESS: 10540 Prospect Avenue Santee, CA 92071

TELEPHONE NO.: 619-448-4560

FAX NO.: 619-448-3341

CITY CONTACT: Rosa Riego, Contract Specialist. Email: RRiego@sandiego.gov

Phone No. (619) 533-3426, Fax No. (619) 533-3633

RVejar-Parra / RWBustamante / mlw

BIDDING DOCUMENTS

ORIGINAL



FOR



SEWER & AC WATER GJ 764 & 821

BID NO.: K-17-1544-DBB-3
SAP NO. (WBS/IO/CC): B-15106, B-00368, B-15107, B-00413
CLIENT DEPARTMENT: 2000
COUNCIL DISTRICT: 2
PROJECT TYPE: KB, JA

THIS CONTRACT WILL BE SUBJECT TO THE FOLLOWING:

- PHASED-FUNDING
- THE CITY'S SUBCONTRACTING PARTICIPATION REQUIREMENTS FOR SLBE PROGRAM
- PREVAILING WAGE RATES: STATE FEDERAL
- APPRENTICESHIP

BID DUE DATE:

2:00 PM

APRIL 25, 2017

CITY OF SAN DIEGO

PUBLIC WORKS CONTRACTS

1010 SECOND AVENUE, 14th FLOOR, MS 614C

SAN DIEGO, CA 92101

TABLE OF CONTENTS

SECTION	PAGE
1. NOTICE INVITING BIDS	4
2. INSTRUCTIONS TO BIDDERS	7
3. PERFORMANCE AND PAYMENT BONDS	17
4. ATTACHMENTS:	
A. SCOPE OF WORK.....	20
B. PHASED FUNDING	22
C. INTENTIONALLY LEFT BLANK	25
D. PREVAILING WAGES.....	26
E. SUPPLEMENTARY SPECIAL PROVISIONS.....	30
1. Appendix A - Addendum To A Mitigated Negative Declaration (AMND) and Notice of Determination (NOD).....	53
2. Appendix B - Fire Hydrant Meter Program.....	131
3. Appendix C - Materials Typically Accepted by Certificate of Compliance.....	145
4. Appendix D - Sample City Invoice	147
5. Appendix E - Location Maps	149
6. Appendix F - Adjacent Projects.....	152
7. Appendix G - Hydrostatic Discharge Form	155
8. Appendix H - Discharge Points and Flow Data.....	157
9. Appendix I - Hazardous Label/Forms	159
10. Appendix J - Sewer Mains and Manhole Rehabilitation Sample Data Templates	165
11. Appendix K - Sample Archaeology Invoice	168
12. Appendix L - Sample of Public Notices.....	172
13. Appendix M - Advanced Metering Infrastructure (AMI) Device Protection	174
14. Appendix N - List of the Replumbing.....	181
F. INTENTIONALLY LEFT BLANK.....	183
G. CONTRACT AGREEMENT	184
5. CERTIFICATIONS AND FORMS.....	187

ENGINEER OF WORK

The engineering Specifications and Special Provisions contained herein have been prepared by or under the direction of the following Registered Engineer:

Nabil Samih Batta
For City Engineer

3/14/2017
Date

Seal:

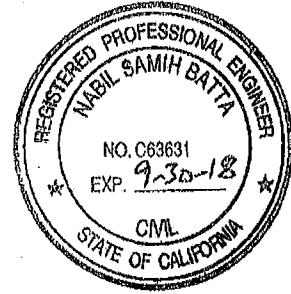

NOTICE INVITING BIDS

1. **SUMMARY OF WORK:** This is the City of San Diego's (City) solicitation process to acquire Construction services for **Sewer & AC Water GJ 764 & 821**. For additional information refer to Attachment A.
2. **FULL AND OPEN COMPETITION:** This contract is open to full competition and may be bid on by Contractors who are on the City's current Prequalified Contractors' List. For information regarding the Contractors Prequalified list visit the City's web site: <http://www.sandiego.gov>.
3. **ESTIMATED CONSTRUCTION COST:** The City's estimated construction cost for this project is **\$8,808,000**.
4. **BID DUE DATE AND TIME ARE: APRIL 25, 2017 at 2:00 PM**
5. **PREVAILING WAGE RATES APPLY TO THIS CONTRACT:** Refer to Attachment D.
6. **LICENSE REQUIREMENT:** The City has determined that the following licensing classifications are required for this contract: **A or C34 and C42**
7. **SUBCONTRACTING PARTICIPATION PERCENTAGES:** Subcontracting participation percentages apply to this contract.
 - 7.1. The City has incorporated **mandatory** SLBE-ELBE subcontractor participation percentages to enhance competition and maximize subcontracting opportunities. For the purpose of achieving the mandatory subcontractor participation percentages, a recommended breakdown of the SLBE and ELBE subcontractor participation percentages based upon certified SLBE and ELBE firms has also been provided to achieve the mandatory subcontractor participation percentages:

1. SLBE participation	7.3%
2. ELBE participation	15.0%
3. Total mandatory participation	22.3%
 - 7.2. The Bid may be declared non-responsive if the Bidder fails to meet the following requirements:
 - 7.2.1. Include SLBE-ELBE certified subcontractors at the overall mandatory participation percentage identified in this document;
 - 7.2.2. Submit Good Faith Effort documentation, saved in searchable Portable Document Format (PDF) and stored on Compact Disc (CD) or Digital Video Disc (DVD), demonstrating the Bidder made a good faith effort to outreach to and include SLBE-ELBE Subcontractors required in this document within 3 Working Days of the Bid opening if the overall mandatory participation percentage is not met.

8. PRE-BID MEETING:

- 8.1.** Prospective Bidders are encouraged to attend the Pre-Bid Meeting. The purpose of the meeting is to discuss the scope of the Project, submittal requirements, the pre-qualification process and any Equal Opportunity Contracting Program requirements and reporting procedures. To request a sign language or oral interpreter for this visit, call the Public Works Contracts Division at (619) 533-3450 at least 5 Working Days prior to the meeting to ensure availability. The Pre-Bid meeting is scheduled as follows:

Date: April 6, 2017
Time: 10:00 AM
Location: 1010 Second Avenue, Suite 1400 (Large Conf Rm.), San Diego, CA 92101

Attendance at the Pre-Submittal Meeting will be evidenced by the Bidder's representative's signature on the attendance roster. It is the responsibility of the Bidder's representative to complete and sign the attendance roster.

9. AWARD PROCESS:

- 9.1.** The Award of this contract is contingent upon the Contractor's compliance with all conditions of Award as stated within these documents and within the Notice of Intent to Award.
- 9.2.** Upon acceptance of a Bid, the City will prepare contract documents for execution within approximately 21 days of the date of the Bid opening. The City will then award the Contract within approximately 14 days of receipt of properly signed Contract, bonds, and insurance documents.
- 9.3.** This contract will be deemed executed and effective only upon the signing of the Contract by the Mayor or his designee and approval as to form the City Attorney's Office.
- 9.4.** The low Bid will be determined by the Base Bid plus all Alternates.
- 9.5.** Once the low bid has been determined, the City may, at its sole discretion, award the contract for the Base Bid alone, or for the Base Bid plus one or more alternates.

10. SUBMISSION OF QUESTIONS:

- 10.1.** The Director (or Designee) of Public Works Department is the officer responsible for opening, examining, and evaluating the competitive Bids submitted to the City for the acquisition, construction and completion of any public improvement except when otherwise set forth in these documents. Any questions related to this solicitation shall be submitted to:

Public Works Contracts
1010 Second Avenue, 14th Floor
San Diego, California, 92101
Attention: Rosa Riego

OR:

RRiego@sandiego.gov

- 10.2.** Questions received less than 14 days prior to the date for opening of Bids may not be considered.
- 10.3.** Questions or clarifications deemed by the City to be material shall be answered via issuance of an addendum and posted to the City's online bidding service.
- 10.4.** Only questions answered by formal written addenda shall be binding. Oral and other interpretations or clarifications shall be without legal effect. It is the Bidder's responsibility to be informed of any addenda that have been issued and to include all such information in its Bid.

- 11. PHASED FUNDING:** For Phased Funding Conditions, see Attachment B.

12. ADDITIVE ALTERNATES:

- 12.1.** The additive alternates have been established to allow the City to compare the cost of specific portions of the Work with the Project's budget and enable the City to make a decision whether to incorporate these portions prior to award. The award will be established as described in the Bid. The City reserves the right to award the Contract for the Base Bid only or for the Base Bid plus one or more Alternates.
- 12.2.** For water pipeline projects, the Plans typically show all cut and plug and connection work to be performed by City Forces. However, Bidders shall refer to Bidding Documents to see if all or part of this work will be performed by the Contractor.

INSTRUCTIONS TO BIDDERS

1. PREQUALIFICATION OF CONTRACTORS:

- 1.1. Contractors submitting a Bid must be pre-qualified for the total amount proposed, including all alternate items, prior to the date of submittal. Bids from contractors who have not been pre-qualified as applicable and Bids that exceed the maximum dollar amount at which contractors are pre-qualified may be deemed **non-responsive** and ineligible for award. Complete information and links to the on-line prequalification application are available at:

<http://www.sandiego.gov/cip/bidopps/prequalification.shtml>

- 1.2. The completed application must be submitted online no later than 2 weeks prior to the bid opening. For additional information or the answer to questions about the prequalification program, contact David Stucky at 619-533-3474 or dstucky@sandiego.gov.
- 1.3. Due to the City's fiduciary requirement to safeguard vendor data, City staff will not be able to provide information regarding contractors' prequalification status over the telephone. Contractors may access real-time information about their prequalification status via their vendor profile on [PlanetBids™](#).

2. ELECTRONIC FORMAT RECEIPT AND OPENING OF BIDS: Bids will be received in electronic format (eBids) EXCLUSIVELY at the City of San Diego's electronic bidding (eBidding) site, at: <http://www.sandiego.gov/cip/bidopps/index.shtml> and are due by the date, and time shown on the cover of this solicitation.

- 2.1. **BIDDERS MUST BE PRE-REGISTERED** with the City's bidding system and possess a system-assigned Digital ID in order to submit and electronic bid.
- 2.2. The City's bidding system will automatically track information submitted to the site including IP addresses, browsers being used and the URLs from which information was submitted. In addition, the City's bidding system will keep a history of every login instance including the time of login, and other information about the user's computer configuration such as the operating system, browser type, version, and more. Because of these security features, Contractors who disable their browsers' cookies will not be able to log in and use the City's bidding system.
- 2.3. The City's electronic bidding system is responsible for bid tabulations. Upon the bidder's or proposer's entry of their bid, the system will ensure that all required fields are entered. **The system will not accept a bid for which any required information is missing.** This includes all necessary pricing, subcontractor listing(s) and any other essential documentation and supporting materials and forms requested or contained in these solicitation documents.

2.4. BIDS REMAIN SEALED UNTIL BID DEADLINE. eBids are transmitted into the City's bidding system via hypertext transfer protocol secure (https) mechanism using SSL 128-256 bit security certificates issued from Verisign/Thawte which encrypts data being transferred from client to server. Bids submitted prior to the "Bid Due Date and Time" are not available for review by anyone other than the submitter which has until the "Bid Due Date and Time" to change, rescind or retrieve its proposal should it desire to do so.

2.5. BIDS MUST BE SUBMITTED BY BID DUE DATE AND TIME. Once the bid deadline is reached, no further submissions are accepted into the system. Once the Bid Due Date and Time has lapsed, bidders, proposers, the general public, and City staff are able to immediately see the results on line. City staff may then begin reviewing the submissions for responsiveness, EOCP compliance and other issues. The City may require any Bidder to furnish statement of experience, financial responsibility, technical ability, equipment, and references.

2.6. RECAPITULATION OF THE WORK. Bids shall not contain any recapitulation of the Work. Conditional Bids may be rejected as being non-responsive. Alternative proposals will not be considered unless called for.

2.7. BIDS MAY BE WITHDRAWN by the Bidder only up to the bid due date and time.

2.7.1. Important Note: Submission of the electronic bid into the system may not be instantaneous. Due to the speed and capabilities of the user's internet service provider (ISP), bandwidth, computer hardware and other variables, it may take time for the bidder's submission to upload and be received by the City's eBidding system. It is the bidder's sole responsibility to ensure their bids are received on time by the City's eBidding system. The City of San Diego is not responsible for bids that do not arrive by the required date and time.

2.8. ACCESSIBILITY AND AMERICANS WITH DISABILITIES ACT (ADA) COMPLIANCE: To request a copy of this solicitation in an alternative format, contact the Public Works Contract Specialist listed on the cover of this solicitation at least five (5) working days prior to the Bid/Proposal due date to ensure availability.

3. ELECTRONIC BID SUBMISSIONS CARRY FULL FORCE AND EFFECT

3.1. The bidder, by submitting its electronic bid, acknowledges that doing so carries the same force and full legal effect as a paper submission with a longhand (wet) signature.

3.2. By submitting an electronic bid, the bidder certifies that the bidder has thoroughly examined and understands the entire Contract Documents (which consist of the plans and specifications, drawings, forms, affidavits and the solicitation

documents), and that by submitting the eBid as its bid proposal, the bidder acknowledges, agrees to and is bound by the entire Contract Documents, including any addenda issued thereto, and incorporated by reference in the Contract Documents.

3.3. The Bidder, by submitting its electronic bid, agrees to and certifies under penalty of perjury under the laws of the State of California, that the certification, forms and affidavits submitted as part of this bid are true and correct.

3.4. The Bidder agrees to the construction of the project as described in Attachment "A-Scope of Work" for the City of San Diego, in accordance with the requirements set forth herein for the electronically submitted prices. The Bidder guarantees the Contract Price for a period of 120 days (90 days for federally funded contracts and contracts valued at \$500,000 or less) from the date of Bid opening. The duration of the Contract Price guarantee shall be extended by the number of days required for the City to obtain all items necessary to fulfill all conditions precedent.

4. BIDS ARE PUBLIC RECORDS: Upon receipt by the City, Bids shall become public records subject to public disclosure. It is the responsibility of the respondent to clearly identify any confidential, proprietary, trade secret or otherwise legally privileged information contained within the Bid. General references to sections of the California Public Records Act (PRA) will not suffice. If the Contractor does not provide applicable case law that clearly establishes that the requested information is exempt from the disclosure requirements of the PRA, the City shall be free to release the information when required in accordance with the PRA, pursuant to any other applicable law, or by order of any court or government agency, and the Contractor will hold the City harmless for release of this information.

5. CONTRACTOR REGISTRATION AND ELECTRONIC REPORTING SYSTEM:

5.1. Prior to the Award of the Contract or Task Order, you and your Subcontractors and Suppliers must register with the City's web-based vendor registration and bid management system. For additional information go to:

<http://www.sandiego.gov/purchasing/bids-contracts/vendorreg.shtml>.

5.2. The City may not award the contract until registration of all subcontractors and suppliers is complete. In the event this requirement is not met within the time frame specified in the Notice of Intent to Award letter, the City reserves the right to rescind the Notice of Award / Intent to Award and to make the award to the next responsive and responsible bidder / proposer.

6. JOINT VENTURE CONTRACTORS: Provide a copy of the Joint Venture agreement and the Joint Venture license to the City within 10 Working Days after receiving the Contract forms. See 7-6, "The Contractors Representative" in The GREENBOOK and 7-6.1 in The WHITEBOOK.

7. **PREVAILING WAGE RATES WILL APPLY:** Refer to Attachment D.
8. **SUBCONTRACTING PARTICIPATION PERCENTAGES:** Subcontracting participation percentages apply to this contract. Refer to Attachment E.
9. **INSURANCE REQUIREMENTS:**
- 9.1. All certificates of insurance and endorsements required by the contract are to be provided upon issuance of the City's Notice of Intent to Award letter.
- 9.2. Refer to sections 7-3, "LIABILITY INSURANCE", and 7-4, "WORKERS' COMPENSATION INSURANCE" of the Supplementary Special Provisions (SSP) for the insurance requirements which must be met.
10. **REFERENCE STANDARDS:** Except as otherwise noted or specified, the Work shall be completed in accordance with the following standards:

Title	Edition	Document Number
Standard Specifications for Public Works Construction ("The GREENBOOK") http://www.greenbookspecs.org/	2015	PWPI070116-01
City of San Diego Standard Specifications for Public Works Construction ("The WHITEBOOK")* https://www.sandiego.gov/publicworks/edocref/greenbook	2015	PWPI070116-02
City of San Diego Standard Drawings* https://www.sandiego.gov/publicworks/edocref/standarddraw	2016	PWPI070116-03
Citywide Computer Aided Design and Drafting (CADD) Standards https://www.sandiego.gov/publicworks/edocref/drawings	2016	PWPI092816-04
California Department of Transportation (CALTRANS) Standard Specifications – http://www.dot.ca.gov/des/oe/construction-contract-standards.html	2015	PWPI092816-05
CALTRANS Standard Plans http://www.dot.ca.gov/des/oe/construction-contract-standards.html	2015	PWPI092816-06
California Manual on Uniform Traffic Control Devices Revision 1 (CA MUTCD Rev 1) - http://www.dot.ca.gov/trafficops/camutcd/	2014	PWPI092816-07
NOTE: *Available online under Engineering Documents and References at: http://www.sandiego.gov/publicworks/edocref/index.shtml		

11. **CITY'S RESPONSES AND ADDENDA:** The City, at its discretion, may respond to any or all questions submitted in writing via the City's eBidding web site in the **form of an addendum**. No other responses to questions, oral or written shall be of any force or effect with respect to this solicitation. The changes to the Contract Documents through addenda are made effective as though originally issued with the Bid. The Bidders shall acknowledge the receipt of Addenda at the time of bid submission.
12. **CITY'S RIGHTS RESERVED:** The City reserves the right to cancel the Notice Inviting Bids at any time, and further reserves the right to reject submitted Bids, without giving any reason for such action, at its sole discretion and without liability. Costs incurred by the Bidder(s) as a result of preparing Bids under the Notice Inviting Bids shall be the sole responsibility of each bidder. The Notice Inviting Bids creates or imposes no obligation upon the City to enter a contract.
13. **CONTRACT PRICING:** This solicitation is for a Lump Sum contract with Unit Price provisions as set forth herein. The Bidder agrees to perform construction services for the City of San Diego in accordance with these contract documents for the prices listed below. The Bidder further agrees to guarantee the Contract Price for a period of 120 days from the date of Bid opening. The duration of the Contract Price guarantee may be extended, by mutual consent of the parties, by the number of days required for the City to obtain all items necessary to fulfill all contractual conditions.
14. **SUBCONTRACTOR INFORMATION:**
 - 14.1. **LISTING OF SUBCONTRACTORS.** In accordance with the requirements provided in the "Subletting and Subcontracting Fair Practices Act" of the California Public Contract Code, the Bidder shall provide the **NAME** and **ADDRESS** of each Subcontractor who will perform work, labor, render services or who specially fabricates and installs a portion [type] of the work or improvement, in an amount in excess of 0.5% of the Contractor's total Bid. The Bidder shall also state within the description, whether the subcontractor is a **CONSTRUCTOR, CONSULTANT** or **SUPPLIER**. The Bidder shall further state within the description, the **PORTION** of the work which will be performed by each subcontractor under this Contract. The Contractor shall list only one Subcontractor for each portion of the Work. The **DOLLAR VALUE** of the total Bid to be performed shall be stated for all subcontractors listed. Failure to comply with this requirement may result in the Bid being rejected as **non-responsive** and ineligible for award. The Bidder's attention is directed to the Special Provisions - General; Paragraph 2-3, "Subcontracts", which stipulates the percent of the Work to be performed with the Bidders' own forces. The Bidder shall list all SLBE, ELBE, DBE, DVBE, MBE, WBE, OBE, SDB, WoSB, HUBZone, and SDVOSB Subcontractors for which Bidders are seeking recognition towards achieving any mandatory, voluntary (or both) subcontracting participation goals.

- 14.2. LISTING OF SUPPLIERS.** Any Bidder seeking the recognition of Suppliers of equipment, materials, or supplies obtained from third party Suppliers towards achieving any mandatory or voluntary (or both) subcontracting participation goals shall provide, at a minimum, the **NAME, LOCATION (CITY)** and the **DOLLAR VALUE** of each supplier. The Bidder will be credited up to 60% of the amount to be paid to the Suppliers for materials and supplies unless vendor manufactures or substantially alters materials and supplies, in which case, 100% will be credited. The Bidder is to indicate within the description whether the listed firm is a supplier or manufacturer. If no indication is provided, the listed firm will be credited at 60% of the listed dollar value for purposes of calculating the Subcontractor Participation Percentage.
- 14.3. LISTING OF SUBCONTRACTORS OR SUPPLIERS FOR ALTERNATES.** For subcontractors or suppliers to be used on additive or deductive alternate items, in addition to the above requirements, bidder shall further note "ALTERNATE" and alternate item number within the description.
- 15. SUBMITTAL OF "OR EQUAL" ITEMS:** See Section 4-1.6, "Trade Names or Equals" in The WHITEBOOK and as amended in the SSP.
- 16. AWARD:**
- 16.1.** The Award of this contract is contingent upon the Contractor's compliance with all conditions precedent to Award.
- 16.2.** Upon acceptance of a Bid, the City will prepare contract documents for execution within approximately 21 days of the date of the Bid opening and award the Contract approximately within 7 days of receipt of properly executed Contract, bonds, and insurance documents.
- 16.3.** This contract will be deemed executed and effective only upon the signing of the Contract by the Mayor or his designee and approval as to form the City Attorney's Office.
- 17. SUBCONTRACT LIMITATIONS:** The Bidder's attention is directed to Standard Specifications for Public Works Construction, Section 2-3, "SUBCONTRACTS" in The GREENBOOK and as amended in the SSP which requires the Contractor to self-perform not less than the specified amount. Failure to comply with this requirement shall render the bid **non-responsive** and ineligible for award.
- 18. AVAILABILITY OF PLANS AND SPECIFICATIONS:** Contract Documents may be obtained by visiting the City's website: <http://www.sandiego.gov/cip/>. Plans and Specifications for this contract are also available for review in the office of the City Clerk or Public Works Contracts.

19. **ONLY ONE BID PER CONTRACTOR SHALL BE ACCEPTED:** No person, firm, or corporation shall be allowed to make, file, or be interested in more than one (1) Bid for the same work unless alternate Bids are called for. A person, firm or corporation who has submitted a sub-proposal to a Bidder, or who has quoted prices on materials to a Bidder, is not hereby disqualified from submitting a sub-proposal or quoting prices to other Bidders or from submitting a Bid in its own behalf. Any Bidder who submits more than one bid will result in the rejection of all bids submitted.
20. **SAN DIEGO BUSINESS TAX CERTIFICATE:** The Contractor and Subcontractors, not already having a City of San Diego Business Tax Certificate for the work contemplated shall secure the appropriate certificate from the City Treasurer, Civic Center Plaza, First floor and submit to the Contract Specialist upon request or as specified in the Contract Documents. Tax Identification numbers for both the Bidder and the listed Subcontractors must be submitted on the City provided forms within these documents.
21. **BIDDER'S GUARANTEE OF GOOD FAITH (BID SECURITY) FOR DESIGN-BID-BUILD CONTRACTS:**
- 21.1. For bids \$250,000 and above, bidders shall submit Bid Security at bid time. Bid Security shall be in one of the following forms: a cashier's check, or a properly certified check upon some responsible bank; or an approved corporate surety bond payable to the City of San Diego for an amount of not less than 10% of the total bid amount.
- 21.2. This check or bond, and the monies represented thereby, will be held by the City as a guarantee that the Bidder, if awarded the contract, will in good faith enter into the contract and furnish the required final performance and payment bonds.
- 21.3. The Bidder agrees that in the event of the Bidder's failure to execute this contract and provide the required final bonds, the money represented by the cashier's or certified check will remain the property of the City; and the Surety agrees that it will pay to the City the damages, not exceeding the sum of 10% of the amount of the Bid, that the City may suffer as a result of such failure.
- 21.4. At the time of bid submission, bidders must upload and submit an electronic PDF copy of the aforementioned bid security. Whether in the form of a cashier's check, a properly certified check or an approved corporate surety bond payable to the City of San Diego, the bid security must be uploaded to the City's eBidding system. Within twenty-four (24) hours after the bid due date and time, the first five (5) apparent low bidders must provide the City with the original bid security.
- 21.5. Failure to submit the electronic version of the bid security at the time of bid submission AND failure to provide the original within twenty-four (24) hours may cause the bid to be rejected and deemed **non-responsive**.

22. AWARD OF CONTRACT OR REJECTION OF BIDS:

- 22.1.** This contract may be awarded to the lowest responsible and reliable Bidder.
- 22.2.** Bidders shall complete ALL eBid forms as required by this solicitation. Incomplete eBids will not be accepted.
- 22.3.** The City reserves the right to reject any or all Bids, to waive any informality or technicality in Bids received, and to waive any requirements of these specifications as to bidding procedure.
- 22.4.** Bidders will not be released on account of their errors of judgment. Bidders may be released only upon receipt by the City within 3 Working Days of the bid opening, written notice from the Bidder which shows proof of honest, credible, clerical error of a material nature, free from fraud or fraudulent intent; and of evidence that reasonable care was observed in the preparation of the Bid.
- 22.5.** A bidder who is not selected for contract award may protest the award of a contract to another bidder by submitting a written protest in accordance with the San Diego Municipal Code.
- 22.6.** The City of San Diego will not discriminate in the award of contracts with regard to race, religion creed, color, national origin, ancestry, physical handicap, marital status, sex or age.
- 22.7.** Each Bid package properly signed as required by these specifications shall constitute a firm offer which may be accepted by the City within the time specified herein.
- 22.8.** The City reserves the right to evaluate all Bids and determine the lowest Bidder on the basis of the base bid and any proposed alternates or options as detailed herein.

23. BID RESULTS:

- 23.1.** The availability of the bids on the City's eBidding system shall constitute the public announcement of the apparent low bidder. In the event that the apparent low bidder is subsequently deemed non-responsive or non-responsible, a notation of such will be made on the eBidding system. The new ranking and apparent low bidder will be adjusted accordingly.
- 23.2.** To obtain the bid results, view the results on the City's web site, or request the results by U.S. mail and provide a self-addressed, stamped envelope. If requesting by mail, be sure to reference the bid name and number. The bid tabulations will be mailed to you upon their completion. The results will not be given over the telephone.

24. THE CONTRACT:

- 24.1.** The Bidder to whom award is made shall execute a written contract with the City of San Diego and furnish good and approved bonds and insurance certificates specified by the City within 14 days after receipt by Bidder of a form of contract for execution unless an extension of time is granted to the Bidder in writing.
- 24.2.** If the Bidder takes longer than 14 days to fulfill these requirements, then the additional time taken shall be added to the Bid guarantee. The Contract shall be made in the form adopted by the City, which includes the provision that no claim or suit whatsoever shall be made or brought by Contractor against any officer, agent, or employee of the City for or on account of anything done or omitted to be done in connection with this contract, nor shall any such officer, agent, or employee be liable hereunder.
- 24.3.** If the Bidder to whom the award is made fails to enter into the contract as herein provided, the award may be annulled and the Bidder's Guarantee of Good Faith will be subject to forfeiture. An award may be made to the next lowest responsible and reliable Bidder who shall fulfill every stipulation embraced herein as if it were the party to whom the first award was made.
- 24.4.** Pursuant to the San Diego City Charter section 94, the City may only award a public works contract to the lowest responsible and reliable Bidder. The City will require the Apparent Low Bidder to (i) submit information to determine the Bidder's responsibility and reliability, (ii) execute the Contract in form provided by the City, and (iii) furnish good and approved bonds and insurance certificates specified by the City within 14 Days, unless otherwise approved by the City, in writing after the Bidder receives notification from the City, designating the Bidder as the Apparent Low Bidder and formally requesting the above mentioned items.
- 24.5.** The award of the Contract is contingent upon the satisfactory completion of the above-mentioned items and becomes effective upon the signing of the Contract by the Mayor or designee and approval as to form the City Attorney's Office. If the Apparent Low Bidder does not execute the Contract or submit required documents and information, the City may award the Contract to the next lowest responsible and reliable Bidder who shall fulfill every condition precedent to award. A corporation designated as the Apparent Low Bidder shall furnish evidence of its corporate existence and evidence that the officer signing the Contract and bond for the corporation is duly authorized to do so.

- 25. EXAMINATION OF PLANS, SPECIFICATIONS, AND SITE OF WORK:** The Bidder shall examine carefully the Project Site, the Plans and Specifications, other materials as described in the Special Provisions, Section 2-7, and the proposal forms (e.g., Bidding Documents). The submission of a Bid shall be conclusive evidence that the Bidder has investigated and is satisfied as to the conditions to be encountered, as to the character,

quality, and scope of Work, the quantities of materials to be furnished, and as to the requirements of the Bidding Documents Proposal, Plans, and Specifications.

26. CITY STANDARD PROVISIONS: This contract is subject to the following standard provisions. See The WHITEBOOK for details.

- 26.1.** The City of San Diego Resolution No. R-277952 adopted on May 20, 1991 for a Drug-Free Workplace.
- 26.2.** The City of San Diego Resolution No. R-282153 adopted on June 14, 1993 related to the Americans with Disabilities Act.
- 26.3.** The City of San Diego Municipal Code §22.3004 for Contractor Standards.
- 26.4.** The City of San Diego's Labor Compliance Program and the State of California Labor Code §§1771.5(b) and 1776.
- 26.5.** Sections 1777.5, 1777.6, and 1777.7 of the State of California Labor Code concerning the employment of apprentices by contractors and subcontractors performing public works contracts.
- 26.6.** The City's Equal Benefits Ordinance (EBO), Chapter 2, Article 2, Division 43 of The San Diego Municipal Code (SDMC).
- 26.7.** The City's Information Security Policy (ISP) as defined in the City's Administrative Regulation 90.63.

27. PRE-AWARD ACTIVITIES:

- 27.1.** The contractor selected by the City to execute a contract for this Work shall submit the required documentation as specified in the herein and in the Notice of Award. Failure to provide the information as specified may result in the Bid being rejected as **non-responsive**.
- 27.2.** The decision that bid is non-responsive for failure to provide the information required within the time specified shall be at the sole discretion of the City.

PERFORMANCE BOND, LABOR AND MATERIALMEN'S BOND

FAITHFUL PERFORMANCE BOND AND LABOR AND MATERIALMEN'S BOND:

TC Construction Company, Inc. _____, a corporation, as principal, and
Liberty Mutual Insurance Company _____, a corporation authorized to do
business in the State of California, as Surety, hereby obligate themselves, their successors
and assigns, jointly and severally, to The City of San Diego a municipal corporation in the
sum of **Eight Million Seven Hundred Eighty-Five Thousand Seven Hundred Seventy-Six
Dollars and Twenty-Two Cents (\$8,785,776.22)** for the faithful performance of the
annexed contract, and in the sum of **Eight Million Seven Hundred Eighty-Five Thousand
Seven Hundred Seventy-Six Dollars and Twenty-Two Cents (\$8,785,776.22)** for the
benefit of laborers and materialmen designated below.

Conditions:

If the Principal shall faithfully perform the annexed contract with the City of San Diego, California, then the obligation herein with respect to a faithful performance shall be void; otherwise it shall remain in full force.

If the Principal shall promptly pay all persons, firms and corporations furnishing materials for or performing labor in the execution of this contract, and shall pay all amounts due under the California Unemployment Insurance Act then the obligation herein with respect to laborers and materialmen shall be void; otherwise it shall remain in full force.

The obligation herein with respect to laborers and materialmen shall inure to the benefit of all persons, firms and corporations entitled to file claims under the provisions of Article 2. Claimants, (III) public works of improvement commencing with Civil Code Section 9100 of the Civil Code of the State of California.

Changes in the terms of the annexed contract or specifications accompanying same or referred to therein shall not affect the Surety's obligation on this bond, and the Surety hereby waives notice of same.

The Surety shall pay reasonable attorney's fees should suit be brought to enforce the provisions of this bond.

PERFORMANCE BOND, LABOR AND MATERIALMEN'S BOND (continued)

Dated May 23, 2017

Approved as to Form

TC Construction Company, Inc.

Principal

By 

AUSTIN CAMERON, PRESIDENT

Printed Name of Person Signing for Principal

Mara W. Elliott, City Attorney

By 

Deputy City Attorney

Liberty Mutual Insurance Company

Surety

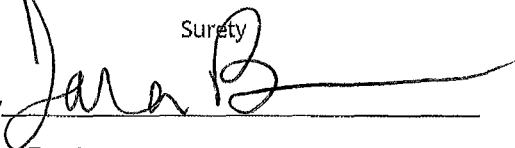
By 

Tara Bacon, Attorney-in-fact

Approved:

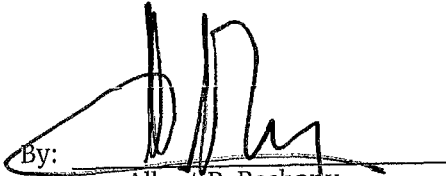
By: 

Albert P. Rechar
Deputy Director
Public Works Department

790 The City Drive, Suite 200

Local Address of Surety

Orange, CA 92868

Local Address (City, State) of Surety

(714) 634-3311

Local Telephone No. of Surety

Premium \$ 55,598.00

Bond No. 024067685

CALIFORNIA ALL-PURPOSE ACKNOWLEDGMENT

CIVIL CODE § 1189

A notary public or other officer completing this certificate verifies only the identity of the individual who signed the document to which this certificate is attached, and not the truthfulness, accuracy, or validity of that document.

State of California)

County of San Diego)

On May 25, 2017 before me, Sandra Weeks, Notary Public
Date Here Insert Name and Title of the Officer

personally appeared Austin Cameron
Name(s) of Signer(s)

who proved to me on the basis of satisfactory evidence to be the person(s) whose name(s) ~~is/are~~ subscribed to the within instrument and acknowledged to me that ~~he/she/they~~ executed the same in ~~his/her/their~~ authorized capacity(ies), and that by ~~his/her/their~~ signature(s) on the instrument the person(s) or the entity upon behalf of which the person(s) acted, executed the instrument.

I certify under PENALTY OF PERJURY under the laws of the State of California that the foregoing paragraph is true and correct.

WITNESS my hand and official seal.

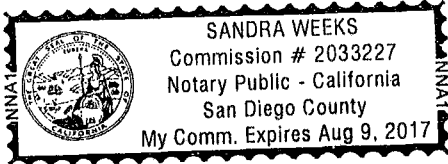

Signature Sandra Weeks
Signature of Notary Public

Place Notary Seal Above

OPTIONAL

Though this section is optional, completing this information can deter alteration of the document or fraudulent reattachment of this form to an unintended document.

Description of Attached Document Performance Bond,
Title or Type of Document: Labor & Materialmen's Bond Document Date: _____
Number of Pages: 1 Signer(s) Other Than Named Above: N/A

Capacity(ies) Claimed by Signer(s)
Signer's Name: Austin Cameron Signer's Name: N/A
 Corporate Officer — Title(s): President Corporate Officer — Title(s): _____
 Partner — Limited General Partner — Limited General
 Individual Attorney in Fact Individual Attorney in Fact
 Trustee Guardian or Conservator Trustee Guardian or Conservator
 Other: _____ Other: _____
Signer Is Representing: TC Construction Co, Inc. Signer Is Representing: _____

CALIFORNIA ALL-PURPOSE ACKNOWLEDGMENT
CIVIL CODE § 1189

A notary public or other officer completing this certificate verifies only the identity of the individual who signed the document to which this certificate is attached, and not the truthfulness, accuracy, or validity of that document.

State of California
County of San Diego)

On May 23, 2017 before me, Diana Kai Murphy, Notary Public
(insert name and title of the officer)

personally appeared Tara Bacon
who proved to me on the basis of satisfactory evidence to be the person(s) whose name(s) is/are subscribed to the within instrument and acknowledged to me that he/she/they executed the same in his/her/their authorized capacity(ies), and that by his/her/their signature(s) on the instrument the person(s), or the entity upon behalf of which the person(s) acted, executed the instrument.

I certify under PENALTY OF PERJURY under the laws of the State of California that the foregoing paragraph is true and correct.

WITNESS my hand and official seal.

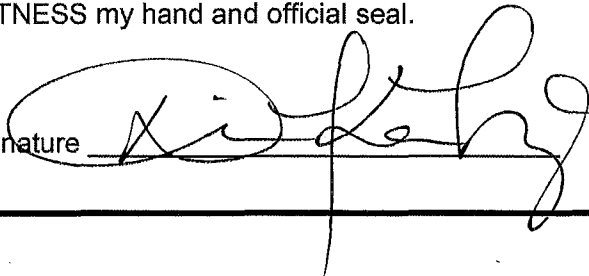
Signature  (Seal)



THIS POWER OF ATTORNEY IS NOT VALID UNLESS IT IS PRINTED ON RED BACKGROUND.

This Power of Attorney limits the acts of those named herein, and they have no authority to bind the Company except in the manner and to the extent herein stated.

Certificate No. 7552313

Liberty Mutual Insurance Company
The Ohio Casualty Insurance Company West American Insurance Company

POWER OF ATTORNEY

KNOWN ALL PERSONS BY THESE PRESENTS: That The Ohio Casualty Insurance Company is a corporation duly organized under the laws of the State of New Hampshire, that Liberty Mutual Insurance Company is a corporation duly organized under the laws of the State of Massachusetts, and West American Insurance Company is a corporation duly organized under the laws of the State of Indiana (herein collectively called the "Companies"), pursuant to and by authority herein set forth, does hereby name, constitute and appoint, Bradley R. Orr; Dale G. Harshaw; Geoffrey Shelton; John R. Qualin; Kyle King; Minna Huovila; Tara Bacon

all of the city of San Diego, state of CA each individually if there be more than one named, its true and lawful attorney-in-fact to make, execute, seal, acknowledge and deliver, for and on its behalf as surety and as its act and deed, any and all undertakings, bonds, recognizances and other surety obligations, in pursuance of these presents and shall be as binding upon the Companies as if they have been duly signed by the president and attested by the secretary of the Companies in their own proper persons.

IN WITNESS WHEREOF, this Power of Attorney has been subscribed by an authorized officer or official of the Companies and the corporate seals of the Companies have been affixed thereto this 22nd day of November, 2016.



The Ohio Casualty Insurance Company
Liberty Mutual Insurance Company
West American Insurance Company

By: David M. Carey
David M. Carey, Assistant Secretary

STATE OF PENNSYLVANIA ss
COUNTY OF MONTGOMERY

On this 22nd day of November, 2016, before me personally appeared David M. Carey, who acknowledged himself to be the Assistant Secretary of Liberty Mutual Insurance Company, The Ohio Casualty Company, and West American Insurance Company, and that he, as such, being authorized so to do, execute the foregoing instrument for the purposes therein contained by signing on behalf of the corporations by himself as a duly authorized officer.

IN WITNESS WHEREOF, I have hereunto subscribed my name and affixed my notarial seal at King of Prussia, Pennsylvania, on the day and year first above written.



COMMONWEALTH OF PENNSYLVANIA
Notarial Seal
Teresa Pastella, Notary Public
Upper Merion Twp., Montgomery County
My Commission Expires March 28, 2017
Member, Pennsylvania Association of Notaries

By: Teresa Pastella
Teresa Pastella, Notary Public

This Power of Attorney is made and executed pursuant to and by authority of the following By-laws and Authorizations of The Ohio Casualty Insurance Company, Liberty Mutual Insurance Company, and West American Insurance Company which resolutions are now in full force and effect reading as follows:

ARTICLE IV – OFFICERS – Section 12. Power of Attorney. Any officer or other official of the Corporation authorized for that purpose in writing by the Chairman or the President, and subject to such limitation as the Chairman or the President may prescribe, shall appoint such attorneys-in-fact, as may be necessary to act in behalf of the Corporation to make, execute, seal, acknowledge and deliver as surety any and all undertakings, bonds, recognizances and other surety obligations. Such attorneys-in-fact, subject to the limitations set forth in their respective powers of attorney, shall have full power to bind the Corporation by their signature and execution of any such instruments and to attach thereto the seal of the Corporation. When so executed, such instruments shall be as binding as if signed by the President and attested to by the Secretary. Any power or authority granted to any representative or attorney-in-fact under the provisions of this article may be revoked at any time by the Board, the Chairman, the President or by the officer or officers granting such power or authority.

ARTICLE XIII – Execution of Contracts – SECTION 5. Surety Bonds and Undertakings. Any officer of the Company authorized for that purpose in writing by the chairman or the president, and subject to such limitations as the chairman or the president may prescribe, shall appoint such attorneys-in-fact, as may be necessary to act in behalf of the Company to make, execute, seal, acknowledge and deliver as surety any and all undertakings, bonds, recognizances and other surety obligations. Such attorneys-in-fact subject to the limitations set forth in their respective powers of attorney, shall have full power to bind the Company by their signature and execution of any such instruments and to attach thereto the seal of the Company. When so executed such instruments shall be as binding as if signed by the president and attested by the secretary.

Certificate of Designation – The President of the Company, acting pursuant to the Bylaws of the Company, authorizes David M. Carey, Assistant Secretary to appoint such attorneys-in-fact as may be necessary to act on behalf of the Company to make, execute, seal, acknowledge and deliver as surety any and all undertakings, bonds, recognizances and other surety obligations.

Authorization – By unanimous consent of the Company's Board of Directors, the Company consents that facsimile or mechanically reproduced signature of any assistant secretary of the Company, wherever appearing upon a certified copy of any power of attorney issued by the Company in connection with surety bonds, shall be valid and binding upon the Company with the same force and effect as though manually affixed.

I, Renee C. Llewellyn, the undersigned, Assistant Secretary, The Ohio Casualty Insurance Company, Liberty Mutual Insurance Company, and West American Insurance Company do hereby certify that the original power of attorney of which the foregoing is a full, true and correct copy of the Power of Attorney executed by said Companies, is in full force and effect and has not been revoked.

IN TESTIMONY WHEREOF, I have hereunto set my hand and affixed the seals of said Companies this 23rd day of May, 2017.



By: Renee C. Llewellyn
Renee C. Llewellyn, Assistant Secretary

Not valid for mortgage, note, loan, letter of credit, currency rate, interest rate or residual value guarantees.

To confirm the validity of this Power of Attorney call 1-610-832-8240 between 9:00 am and 4:30 pm EST on any business day.

ATTACHMENTS

ATTACHMENT A
SCOPE OF WORK

SCOPE OF WORK

1. **SCOPE OF WORK:** Construction consists of the replacement of existing water & sewer mains with new 8 inch, 12 inch water main, appurtenances, water services, fire hydrants, existing water main removal and abandonment, and rehabilitation of existing 8 inch sewer mains, laterals, manholes, and removal and abandonment of existing sewer main, street resurfacing, curb ramps, and all other incidental work.

1.1. The Work shall be performed in accordance with:

1.1.1. The Notice Inviting Bids and Plans numbered **39033-1-D** through **39033-33-D**, **39027-1-D** through **39027-30-D** inclusive.

2. **ESTIMATED CONSTRUCTION COST:** The City's estimated construction cost for this project is **\$8,808,000**.

3. **LOCATION OF WORK: The location of the Work is as follows:** See Appendix E – Group 764 and Group 821 Location Maps.

Fenelon Street, Carleton Street, Emerson Street, Avenida de Portugal, Moana Drive, Cedarbrae Lane, Silver Gate Avenue, Rosecroft Lane, San Gorgonio Street, Kellogg Street, San Fernando Street, Moana Drive, Clove Street, San Elijo Street, Charles Street, Dupont Street, Gage Drive, Albion Street, Jennings Street, Wilcox Street, Dudley Street and Warner Street.

4. **CONTRACT TIME:** The Contract Time for completion of the Work shall be **400 Working Days**.

4.1. **CONTRACTOR'S LICENSE CLASSIFICATION:** In accordance with the provisions of California Law, the Contractor shall possess valid, appropriate licenses at the time that the Bid is submitted. Failure to possess the specified licenses may render the Bid as **non-responsive** and ineligible for award.

4.2. The City has determined that the following licensing classifications are required for this contract:

Option	Classifications
1	CLASS A
2	CLASS C34 AND C42

4.3. The Bidder shall satisfy the licensing requirement by meeting **at least** one of the listed options.

ATTACHMENT B
PHASED FUNDING PROVISIONS

PHASED FUNDING PROVISIONS

1. PHASED FUNDING:

- 1.1.** For phased funded contracts, the City typically secures enough funds for the first 90 days of the contract prior to award. Within 10 Working Days after Bid opening date the Apparent Low Bidder must contact the Project Manager to discuss fund availability and the duration of the first phase and submit the Pre-Award Schedule to the City for approval and preparation of the first Phased Funding Schedule Agreement.
- 1.2.** The Apparent Low Bidder will be required to provide a Pre-award Schedule in accordance with 6-1, "CONSTRUCTION SCHEDULE AND COMMENCEMENT OF THE WORK" and 9-3, "PAYMENT" prior to award of Contract.
- 1.3.** If the Bid submitted by the Apparent Low Bidder is rejected by the City for any reason, the next Apparent Low Bidder is to provide the Pre-Award Schedule within 5 Working Days after receiving notice. This process will continue until the City selects an Awardee or rejects all Bids.
- 1.4.** The first Phased Funding Schedule Agreement must show the fund availability for the first phase. Upon selection of the Awardee and acceptance by the City of the Pre-Award Schedule, the City will present the first Phased Funding Schedule Agreement to you.
- 1.5.** At the City's request, meet with the City's project manager before execution of the first Phased Funding Schedule Agreement to discuss their comments and requests for revision to the Pre-Award Schedule.
- 1.6.** Your failure to perform the any of the following may result in the Bid being rejected as non-responsive:
 1. Meet with the City's project manager, if requested to do so, to discuss and respond to the City's comments regarding the Pre-Award Schedule,
 2. Revise the Pre-Award Schedule as requested by the City within the specified 22 Working Days timeframe, or
 3. Execute the first Phased Funding Schedule Agreement within a day after receipt.

PHASED FUNDING SCHEDULE AGREEMENT

NOTE: THIS IS A SAMPLE PHASED FUNDING SCHEDULE AGREEMENT FORM.

The particulars left blank in this sample, such as the total number of phases and the amounts assigned to each phase, will be completed with funding specific information from the Pre-Award Schedule and Construction Cost Loaded Schedule submitted to and approved by the City.

BID NUMBER: K-17-1544-DBB-3

CONTRACT OR TASK TITLE: SEWER & AC WATER GJ 764 & 821

CONTRACTOR: TC CONSTRUCTION COMPANY

Funding Phase		Phase Description	Phase Start	Phase Finish	Not-to-Exceed Amount
Phase 1	Sewer	Work to be completed in Phase 1 shall include Bonds, Mobilization, Trench Shoring and Installation of Sewer Mains, Sewer Manholes and Sewer Laterals associated with this contract and specifications.	NTP	8/31/17	Group 764 - \$500,000
					Group 821 - \$500,000
	Water	Work to be completed in Phase 1 shall include Bonds, Mobilization, Trench Shoring and Installation of Water Pipes, Fire Hydrants and Water Services associated with this contract and specifications.	NTP	8/31/17	Group 764 - \$500,000
					Group 821 - \$500,000
Phase 2	Sewer	Work to be completed in Phase 2 shall include the remaining of the construction activities associated with this contract and specifications.	09/01/17	NOC	Group 764 - \$1,936,119.70
					Group 821 - \$1,872,445.26
	Water	Work to be completed in Phase 2 shall include the remaining of the construction activities associated with this contract and specifications.	09/01/17	NOC	Group 764 - \$1,536,119.69
					Group 821 - \$1,441,091.57
Contract Total					\$8,785,776.22

Notes:

- 1) WHITEBOOK section 9-3.6, "Phased Funding Compensation" applies.
- 2) The total of all funding phases shall be equal to the TOTAL BID PRICE as shown on BID SCHEDULE 1 - PRICES.
- 3) This PHASED FUNDING SCHEDULE AGREEMENT will be incorporated into the CONTRACT and shall only be revised by written modifications to the CONTRACT.

CITY OF SAN DIEGO

PRINT NAME: Robert Hanning
Construction Manager

Signature: _____

Date: 6/7/17

PRINT NAME: Romero Vezar-Palma
Project Manager

Signature: _____

Date: 06/06/17

CONTRACTOR

PRINT NAME: Austin Cameron

Title: President

Signature: _____

Date: 6/6/2017

ATTACHMENT C
INTENTIONALLY LEFT BLANK

ATTACHMENT D
PREVAILING WAGES

APPENDIX D

PREVAILING WAGES

1. **PREVAILING WAGE RATES:** Pursuant to San Diego Municipal Code section 22.3019, construction, alteration, demolition, repair and maintenance work performed under this Contract is subject to State prevailing wage laws. For construction work performed under this Contract cumulatively exceeding \$25,000 and for alteration, demolition, repair and maintenance work performed under this Contract cumulatively exceeding \$15,000, the Contractor and its subcontractors shall comply with State prevailing wage laws including, but not limited to, the requirements listed below.
 - 1.1. **Compliance with Prevailing Wage Requirements.** Pursuant to sections 1720 through 1861 of the California Labor Code, the Contractor and its subcontractors shall ensure that all workers who perform work under this Contract are paid not less than the prevailing rate of per diem wages as determined by the Director of the California Department of Industrial Relations (DIR). This includes work performed during the design and preconstruction phases of construction including, but not limited to, inspection and land surveying work.
 - 1.1.1. Copies of such prevailing rate of per diem wages are on file at the City and are available for inspection to any interested party on request. Copies of the prevailing rate of per diem wages also may be found at <http://www.dir.ca.gov/OPRL/DPreWageDetermination.htm>. Contractor and its subcontractors shall post a copy of the prevailing rate of per diem wages determination at each job site and shall make them available to any interested party upon request.
 - 1.1.2. The wage rates determined by the DIR refer to expiration dates. If the published wage rate does not refer to a predetermined wage rate to be paid after the expiration date, then the published rate of wage shall be in effect for the life of this Contract. If the published wage rate refers to a predetermined wage rate to become effective upon expiration of the published wage rate and the predetermined wage rate is on file with the DIR, such predetermined wage rate shall become effective on the date following the expiration date and shall apply to this Contract in the same manner as if it had been published in said publication. If the predetermined wage rate refers to one or more additional expiration dates with additional predetermined wage rates, which expiration dates occur during the life of this Contract, each successive predetermined wage rate shall apply to this Contract on the date following the expiration date of the previous wage rate. If the last of such predetermined wage rates expires during the life of this Contract, such wage rate shall apply to the balance of the Contract.
 - 1.2. **Penalties for Violations.** Contractor and its subcontractors shall comply with California Labor Code section 1775 in the event a worker is paid less than the prevailing wage rate for the work or craft in which the worker is employed.

- 1.3. Payroll Records.** Contractor and its subcontractors shall comply with California Labor Code section 1776, which generally requires keeping accurate payroll records, verifying and certifying payroll records, and making them available for inspection. Contractor shall require its subcontractors to also comply with section 1776. Contractor and its subcontractors shall submit weekly certified payroll records online via the City's web-based Labor Compliance Program. Contractor is responsible for ensuring its subcontractors submit certified payroll records to the City.
- 1.3.1.** For contracts entered into on or after April 1, 2015, Contractor and their subcontractors shall furnish records specified in Labor Code section 1776 directly to the Labor Commissioner in the manner required by Labor Code section 1771.4.
- 1.4. Apprentices.** Contractor and its subcontractors shall comply with California Labor Code sections 1777.5, 1777.6 and 1777.7 concerning the employment and wages of apprentices. Contractor is held responsible for the compliance of their subcontractors with sections 1777.5, 1777.6 and 1777.7.
- 1.5. Working Hours.** Contractor and their subcontractors shall comply with California Labor Code sections 1810 through 1815, including but not limited to: (i) restrict working hours on public works contracts to eight hours a day and forty hours a week, unless all hours worked in excess of 8 hours per day are compensated at not less than 1½ times the basic rate of pay; and (ii) specify penalties to be imposed on design professionals and subcontractors of \$25 per worker per day for each day the worker works more than 8 hours per day and 40 hours per week in violation of California Labor Code sections 1810 through 1815.
- 1.6. Required Provisions for Subcontracts.** Contractor shall include at a minimum a copy of the following provisions in any contract they enter into with a subcontractor: California Labor Code sections 1771, 1771.1, 1775, 1776, 1777.5, 1810, 1813, 1815, 1860 and 1861.
- 1.7. Labor Code Section 1861 Certification.** Contractor in accordance with California Labor Code section 3700 is required to secure the payment of compensation of its employees and by signing this Contract, Contractor certifies that "I am aware of the provisions of Section 3700 of the California Labor Code which require every employer to be insured against liability for workers' compensation or to undertake self-insurance in accordance with the provisions of that code, and I will comply with such provisions before commencing the performance of the work of this Contract."
- 1.8. Labor Compliance Program.** The City has its own Labor Compliance Program authorized in August 2011 by the DIR. The City will withhold contract payments when payroll records are delinquent or deemed inadequate by the City or other governmental entity, or it has been established after an investigation by the City or other governmental entity that underpayment(s) have occurred. For questions or assistance, please contact the City of San Diego's Equal Opportunity Contracting Department at 619-236-6000.

1.9. Contractor and Subcontractor Registration Requirements. This project is subject to compliance monitoring and enforcement by the DIR. As of March 1, 2015, no contractor or subcontractor may be listed on a bid or proposal for a public works project unless registered with the DIR pursuant to Labor Code section 1725.5. As of April 1, 2015, a contractor or subcontractor shall not be qualified to bid on, be listed in a bid proposal, or enter into any contract for public work, unless currently registered and qualified to perform public work pursuant to Labor Code section 1725.5. By submitting a bid or proposal to the City, Contractor is certifying that he or she has verified that all subcontractors used on this public work project are registered with the DIR in compliance with Labor Code sections 1771.1 and 1725.5, and Contractor shall provide proof of registration to the City upon request.

1.9.1. A Contractor's inadvertent error in listing a subcontractor who is not registered pursuant to Labor Code section 1725.5 in response to a solicitation shall not be grounds for filing a bid protest or grounds for considering the bid non-responsive provided that any of the following apply: (1) the subcontractor is registered prior to bid opening; (2) within twenty-four hours after the bid opening, the subcontractor is registered and has paid the penalty registration fee specified in Labor Code section 1725.5; or (3) the subcontractor is replaced by another registered subcontractor pursuant to Public Contract Code section 4107.

ATTACHMENT E
SUPPLEMENTARY SPECIAL PROVISIONS

SUPPLEMENTARY SPECIAL PROVISIONS

The following Supplementary Special Provisions (SSP) modifies the following documents:

1. The **2015 Edition** of the Standard Specifications for Public Works Construction (The "GREENBOOK").
2. The **2015 Edition** of the City of San Diego Standard Specifications for Public Works Construction (The "WHITEBOOK"), including the following:
 - a) General Provisions (A) for all Contracts.

SECTION 1 - TERMS, DEFINITIONS, ABBREVIATIONS, UNITS OF MEASURE, AND SYMBOLS

- 11-2 TERMS AND DEFINITIONS.** To the "WHITEBOOK", item 54, "Normal Working Hours", ADD the following:

The **Normal Working Hours** are 8:30 AM to 3:30 PM.

SECTION 2 - SCOPE AND CONTROL OF WORK

- 2-3.2 Self Performance.** To the "GREENBOOK", DELETE in its entirety and SUBSTITUTE with the following:

1. You shall perform, with your own organization, Contract Work amounting to at least 50% of the base Bid **AND** 50% of any alternates.

- 2-14.3 Coordination.** To the "WHITEBOOK", ADD the following:

2. Other adjacent City projects are scheduled for construction for the same time period in the vicinity of **Catalina Blvd, & Gage Drive**. See Appendix "**F**" for the approximate location. Coordinate the Work with the adjacent projects as listed below:

a) Catalina Blvd 12" Water and Catalina Sewer Main
Project Manager: Joe Myers at 619-533-6632

b) AC Water & Sewer Group Job 1017
Project Manager: Elham Lotfi at 619-533-5212

- 2-16 CONTRACTOR REGISTRATION AND ELECTRONIC REPORTING SYSTEM.** To the "WHITEBOOK", item 1, DELETE in its entirety.

SECTION 3 – CHANGES IN WORK

3-5.1 **Claims.** To the “WHITEBOOK”, DELETE in its entirety and SUBSTITUTE with the following:

ADD:

3-5.1 **Claims.**

1. A Claim is a written demand by you that seeks an adjustment in the Contract Price, Contract Time, or other relief associated with a dispute arising under or relating to the Contract, including a breach of any provision thereof. A voucher, invoice, or other routine request for payment is not a Claim.
2. A Claim shall conform to these specifications and may be considered after the City has previously denied a request by you for a Change Order seeking the demanded relief.
3. You shall submit a Claim to the Engineer if a dispute occurs that arises from or relates to the Contract. The Claim shall seek all relief to which you assert you are entitled as a result of the event(s) giving rise to the dispute. Your failure to process a Claim in accordance with these specifications shall constitute a waiver of all relief associated with the dispute. Claims are subject to 6-11, “Right to Audit”.
4. You shall continue to perform the Services and Work and shall maintain the Schedule during any dispute proceedings. The Engineer will continue to make payments for undisputed Services and Work.
5. The City’s Claims process specified herein shall not relieve you of your statutory obligations to present claims prior to any action under the California Government Code.

3-5.1.1 **Initiation of Claim.**

1. You shall promptly, but no later than 30 Days after the event(s) giving rise to the Claim, deliver the Claim to the Engineer.
2. You shall not process a Claim unless the Engineer has previously denied a request by you for a Change Order that sought the relief to be pursued in the claim.

3-5.1.1.1 **Claim Certification Submittal.**

1. If your Claim seeks an increase in the Contract Price, the Contract Time, or both, submit with the Claim an affidavit certifying the following:
 - a) The Claim is made in good faith and covers all costs and delays to which you are entitled as a result of the event(s) giving rise to the Claim.
 - b) The amount claimed accurately reflects the adjustments in the Contract Price, the Contract Time, or both to which you believe you are entitled.

- c) All supporting costs and pricing data are current, accurate, and complete to the best of your knowledge. The cost breakdown per item of Work shall be supplied.
- d) You shall ensure that the affidavit is executed by an official who has the authority to legally bind you.

3-5.1.2 Initial Determination.

- 1. The Engineer will respond in writing to your Claim within 30 Days of receipt of the Claim.

3-5.1.3 Settlement Meeting.

- 1. If you disagree with the Initial Determination, you shall request a Settlement Meeting within 30 Days. Upon receipt of this request, the Engineer will schedule the Settlement Meeting within 15 Working Days.

3-5.1.7 City's Final Determination.

- 1. If a settle agreement is not reached, the City shall make a written Final Determination within 10 Working Days after the Settlement Meeting.
- 2. If you disagree with the City's Final Determination, notify the Engineer in writing of your objection within 15 Working Days after receipt of the written determination and file a "Request for Mediation" in accordance with 3-5.2, "Dispute Resolution Process".
- 3. Failure to give notice of objection within the 15 Working Days period shall waive your right to pursue the Claim.

3-5.1.8 Mandatory Assistance.

- 1. If a third party dispute, litigation, or both arises out of or relates in any way to the Services provided under the Contract, upon the City's request, you shall agree to assist in resolving the dispute or litigation. Your assistance includes, but is not limited to the following:
 - a) Providing professional consultations.
 - b) Attending mediations, arbitrations, depositions, trials, or any event related to the dispute resolution and litigation.

3-5.1.8.1 Compensation for Mandatory Assistance.

- 1. The City will reimburse you for reasonable fees and expenses incurred by you for any required assistance rendered in accordance with 3-5.1.8, "Mandatory Assistance" as Extra Work.
- 2. The Engineer will determine whether these fees and expenses were necessary due to your conduct or failure to act.
- 3. If the Engineer determines that the basis of the dispute or litigation in which these fees and expenses were incurred were the result of your conduct or your failure to act in part or in whole, you shall reimburse the City for any payments made for these fees and expenses.

4. Reimbursement may be through any legal means necessary, including the City's withholding of your payment.

3-5.2.3

Selection of Mediator. To the "WHITEBOOK", DELETE in its entirety and SUBSTITUTE with the following:

1. A single mediator, knowledgeable in construction aspects and acceptable to both parties, shall be used to mediate the dispute.
2. To initiate mediation, the initiating party shall serve a Request for Mediation at the American Arbitration Association (AAA) on the opposing party.
3. If AAA is used, the initiating party shall concurrently file with AAA a "Request for Mediation" along with the appropriate fees, a copy of requested mediators marked in preference order, and a preference for available dates.
4. If AAA is selected to coordinate the mediation (Administrator), within 10 Working Days from the receipt of the initiating party's Request for Mediation, the opposing party shall file the following:
 - a) A copy of the list of the preferred mediators listed in preference order after striking any mediators to which they have any objection.
 - b) A preference for available dates.
 - c) Appropriate fees.
5. If the parties cannot agree on a mediator, then each party shall select a mediator and those mediators shall select the neutral third party to mediate the matter.

3-5.3

Forum of Litigation. To the "WHITEBOOK", DELETE in its entirety and SUBSTITUTE with the following:

1. It is the express intention that all legal actions and proceedings related to the Contract or Agreement with the City or to any rights or any relationship between the parties arising therefrom shall be solely and exclusively initiated and maintained in courts of the State of California for the County of San Diego.

4-1.3.1

General. To the "WHITEBOOK", ADD the following:

1. Steel pipe in sizes larger than 18 inches shall require inspection at the source of production.
2. City lab staff or a qualified inspection agency approved by the Engineer shall witness all welding, lining, coating, and testing. You shall incur additional inspection costs outlined in 4-1.3.3, "Inspection of Items Not Locally Produced".
3. All parts of production (including but not limited to product fabrication, welding, testing, lining, and coating of straight pieces and specials) shall be performed or produced in the United States.
4. Welding and all testing shall be performed by certified welders and testing staff with credentials traceable in the United States.

4-1.3.2 Inspection by the Agency. To the "GREENBOOK", DELETE in its entirety and SUBSTITUTE with the following:

1. The City will provide inspection and testing laboratory services within the continental United States within a 200-mile radius of the geographical limits of the City.

4-1.3.3 Inspection of Items Not Locally Produced. To the "WHITEBOOK", DELETE in its entirety.

ADD:

4-1.3.3 Inspection of Items Not Locally Produced. To the "GREENBOOK", DELETE in its entirety and SUBSTITUTE with the following:

1. When you intend to purchase materials, fabricated products, or equipment from sources located more than 200 miles (321.9 km) outside the geographical limits of the City, City Lab staff or a qualified inspection agency approved by the Engineer, shall be engaged at your expense to inspect the materials, equipment, or process.
2. This approval shall be obtained before producing any material or equipment. City Lab staff or inspector shall evaluate the materials for conformance with the requirements of the Plans and Specifications. You shall forward reports required by the Engineer. No materials or equipment shall be shipped nor shall any processing, fabrication or treatment of such materials be done without proper inspection by City Lab staff or the approved agent. Approval by said agent shall not relieve you of responsibility for complying with the requirements of the Contract Documents.
3. The Engineer may elect City Lab staff to perform inspection of an out-of-town manufacturer. You shall incur additional inspection costs of the Engineer including lodging, meals, and incidental expenses based on Federal Per Diem Rates, along with travel and car rental expenses. If the manufacturing plant operates a double shift, a double shift shall be figured in the inspection costs.
 - a) At the option of the Engineer, full time inspection shall continue for the length of the manufacturing period. If the manufacturing period will exceed 3 consecutive weeks, you shall incur additional inspection expenses of the Engineer's supervisor for a trip of 2 Days to the site per month.
 - b) When the Engineer elects City Lab staff to perform out-of-town inspections, the wages of staff employed by the City shall not be part of the additional inspection expenses paid by you.
 - c) Federal Per Diem Rates can be determined at the location below:
<https://www.gsa.gov/portal/content/104877>

4-1.3.6 Preapproved Materials. To the "WHITEBOOK", ADD the following:

3. You shall submit in writing a list of all products to be incorporated in the Work that are on the AML.

4-1.6 Trade Names or Equals. To the "WHITEBOOK", ADD the following:

11. You shall submit your list of proposed substitutions for an "equal" **no later than 5 Working Days after the determination of the Apparent Low Bidder** and on the City's Product Submittal Form available at:

<http://www.sandiego.gov/publicworks/edocref/index.shtml>

SECTION 5 - UTILITIES

5-2 PROTECTION. To the "WHITEBOOK", item 2, ADD the following:

- g) Refer to Appendix "**M**" for more information on the protection of AMI devices.

5-6 COOPERATION. To the "GREENBOOK", ADD the following:

1. Notify SDG&E at least 10 Working Days prior to excavating within 10 feet of SDG&E Underground High Voltage Transmission Power Lines (69 KV and higher).

SECTION 6 - PROSECUTION, PROGRESS AND ACCEPTANCE OF WORK

ADD:

6-3.2.1.1 Environmental Document.

1. The City of San Diego Environmental Analysis Section (EAS) of the Development Services Department has prepared an **Addendum To A Mitigated Negative Declaration (AMND) and a "Notice of Determination (NOD)** for Sewer and AC Water Group 764 and 821, Project No. 509234, as referenced in the Contract Appendix. You shall comply with all requirements of the AMND and NOD, as set forth in Appendix A.
2. Compliance with the City's environmental document shall be included in the Contract Price.

6-3.2.2 Archaeological and Native American Monitoring Program. To the "WHITEBOOK", ADD the following:

4. You shall retain a qualified archaeologist for this Contract. You shall coordinate your activities and Schedule with the activities and schedules of the archaeologist monitor. Notify the Engineer before noon of the Working Day before monitoring is required. See 2-11, "INSPECTION" for details.

6-3.2.3 Paleontological Monitoring Program. To the "WHITEBOOK", ADD the following:

3. You shall retain a qualified paleontologist for this Contract. You shall coordinate your activities and Schedule with the activities and schedules of the paleontologist monitor. Notify the Engineer before noon of the Working Day before monitoring is required. See 2-11, "INSPECTION" for details.

6-7.1 General. To the "WHITEBOOK", item 3, ADD the following:

- d) 30 Days for full depth asphalt final mill and resurfacing work required per SDG-107.
- e) Where shutdowns of 16 inch and larger pipes are required, there is a shutdown moratorium from May until October. Plan and schedule Work accordingly. No additional payment or Working Days will be granted for delays due to the moratorium.

6-8.3 Warranty. To the "WHITEBOOK", item 1, DELETE in its entirety and SUBSTITUTE with the following:

1. Warranty and repair all defective materials and workmanship for a period of 1 year. This call back warranty period shall start on the date that the Work was accepted by the City. Additionally, you shall warranty the Work against all latent and patent defects for a period of 10 years.

SECTION 7 - RESPONSIBILITIES OF THE CONTRACTOR

7-3 INSURANCE. To the "GREENBOOK", DELETE in its entirety and SUBSTITUTE with the following:

7-3 INSURANCE.

1. The insurance provisions herein shall not be construed to limit your indemnity obligations contained in the Contract.

7-3.1 Policies and Procedures.

1. You shall procure the insurance described below, at its sole cost and expense, to provide coverage against claims for loss including injuries to persons or damage to property, which may arise out of or in connection with the performance of the Work by you, your agents, representatives, officers, employees or Subcontractors.
2. Insurance coverage for property damage resulting from your operations is on a replacement cost valuation. The market value will not be accepted.
3. You shall maintain this insurance for the duration of this Contract and at all times thereafter when you are correcting, removing, or replacing Work in

accordance with this Contract. Your liabilities under the Contract, e.g., your indemnity obligations, is not deemed limited to the insurance coverage required by this Contract.

4. The payment for insurance shall be included in the Contract Price as bid by you. Except as specifically agreed to by the City in writing, you are not entitled to any additional payment. Do not begin any Work under this Contract until you have provided and the City has approved all required insurance.
5. Policies of insurance shall provide that the City is entitled to 30 Days (10 Days for cancellation due to non-payment of premium) prior written notice of cancellation or non-renewal of the policy. Maintenance of specified insurance coverage is a material element of the Contract. Your failure to maintain or renew coverage or to provide evidence of renewal during the term of the Contract may be treated by the City as a material breach of the Contract.

7-3.2 Types of Insurance.

7-3.2.1 Commercial General Liability Insurance.

1. Commercial General Liability Insurance shall be written on the current version of the ISO Occurrence form CG 00 01 07 98 or an equivalent form providing coverage at least as broad.
2. The policy shall cover liability arising from premises and operations, XCU (explosions, underground, and collapse), independent contractors, products/completed operations, personal injury and advertising injury, bodily injury, property damage, and liability assumed under an insured's contract (including the tort liability of another assumed in a business contract).
3. There shall be no endorsement or modification limiting the scope of coverage for either "insured vs. insured" claims or contractual liability. You shall maintain the same or equivalent insurance for at least 10 years following completion of the Work.
4. All costs of defense shall be outside the policy limits. Policy coverage shall be in liability limits of not less than the following:

<u>General Annual Aggregate Limit</u>	<u>Limits of Liability</u>
Other than Products/Completed Operations	\$2,000,000
Products/Completed Operations Aggregate Limit	\$2,000,000
Personal Injury Limit	\$1,000,000
Each Occurrence	\$1,000,000

7-3.2.2 Commercial Automobile Liability Insurance.

1. You shall provide a policy or policies of Commercial Automobile Liability Insurance written on the current version of the ISO form CA 00 01 12 90 or

later version or equivalent form providing coverage at least as broad in the amount of \$1,000,000 combined single limit per accident, covering bodily injury and property damage for owned, non-owned, and hired automobiles ("Any Auto").

2. All costs of defense shall be outside the limits of the policy.

7-3.2.3 Contractors Pollution Liability Insurance.

1. You shall procure and maintain at your expense or require your Subcontractor, as described below, to procure and maintain the Contractors Pollution Liability Insurance including contractual liability coverage to cover liability arising out of cleanup, removal, storage, or handling of hazardous or toxic chemicals, materials, substances, or any other pollutants by you or any Subcontractor in an amount not less than \$2,000,000 limit for bodily injury and property damage.
2. All costs of defense shall be outside the limits of the policy. Any such insurance provided by your Subcontractor instead of you shall be approved separately in writing by the City.
3. For approval of a substitution of your Subcontractor's insurance, you shall certify that all activities for which the Contractors Pollution Liability Insurance will provide coverage will be performed exclusively by the Subcontractor providing the insurance. The deductible shall not exceed \$25,000 per claim.
4. Contractual liability shall include coverage of tort liability of another party to pay for bodily injury or property damage to a third person or organization. There shall be no endorsement or modification of the coverage limiting the scope of coverage for either "insured vs. insured" claims or contractual liability.
5. Occurrence based policies shall be procured before the Work commences and shall be maintained for the Contract Time. Claims Made policies shall be procured before the Work commences, shall be maintained for the Contract Time, and shall include a 12 month extended Claims Discovery Period applicable to this contract or the existing policy or policies that shall continue to be maintained for 12 months after the completion of the Work without advancing the retroactive date.
6. Except as provided for under California law, the policy or policies shall provide that the City is entitled to 30 Days prior written notice (10 Days for cancellation due to non-payment of premium) of cancellation or non-renewal of the policy or policies.

7-3.2.4 Contractors Hazardous Transporters Pollution Liability Insurance.

1. You shall provide at your expense or require your Subcontractor to provide, as described below, Contractors Hazardous Transporters Pollution Liability

Insurance including contractual liability coverage to cover liability arising out of transportation of hazardous or toxic, materials, substances, or any other pollutants by you or any Subcontractor in an amount not less than \$2,000,000 limit per occurrence/aggregate for bodily injury and property damage.

2. All costs of defense shall be outside the limits of the policy. The deductible shall not exceed \$25,000 per claim. Any such insurance provided by a subcontractor instead of you shall be approved separately in writing by the City.
3. For approval of the substitution of Subcontractor's insurance the Contractor shall certify that all activities for which Contractors Hazardous Transporters Pollution Liability Insurance will provide coverage will be performed exclusively by the Subcontractor providing the insurance.
4. Contractual liability shall include coverage of tort liability of another party to pay for bodily injury or property damage to a third person or organization. There shall be no endorsement or modification of the coverage limiting the scope of coverage for either "insured vs. insured" claims or contractual liability. Occurrence based policies shall be procured before the Work commences and shall be maintained for the duration of this Contract. Claims Made policies shall be procured before the Work commences, shall be maintained for the duration of this contract, and shall include a 12 month extended Claims Discovery Period applicable to this contract or the existing policy or policies that shall continue to be maintained for 12 months after the completion of the Work under this Contract without advancing the retroactive date.
5. Except as provided for under California law, the policy or policies shall provide that the City is entitled to 30 Days prior written notice (10 Days for cancellation due to non-payment of premium) of cancellation or non-renewal of the policy or policies.

7-3.3 Rating Requirements. Except for the State Compensation Insurance Fund, all insurance required by this Contract as described herein shall be carried only by responsible insurance companies with a rating of, or equivalent to, at least "A-, VI" by A.M. Best Company, that are authorized by the California Insurance Commissioner to do business in the State, and that have been approved by the City.

7-3.3.1 Non-Admitted Carriers. The City will accept insurance provided by non-admitted, "surplus lines" carriers only if the carrier is authorized to do business in the State and is included on the List of Approved Surplus Lines Insurers (LASLI list).

All policies of insurance carried by non-admitted carriers shall be subject to all of the requirements for policies of insurance provided by admitted carriers described herein.

7-3.4 Evidence of Insurance. Furnish to the City documents e.g., certificates of insurance and endorsements evidencing the insurance required herein, and furnish renewal documentation prior to expiration of this insurance. Each required document shall be

signed by the insurer or a person authorized by the insurer to bind coverage on its behalf. We reserve the right to require complete, certified copies of all insurance policies required herein.

7-3.5 Policy Endorsements.

7-3.5.1 Commercial General Liability Insurance.

7-3.5.1.1 Additional Insured.

1. You shall provide at your expense policy endorsement written on the current version of the ISO Occurrence form CG 20 10 11 85 or an equivalent form providing coverage at least as broad.
2. To the fullest extent allowed by law e.g., California Insurance Code §11580.04, the policy shall be endorsed to include the City and its respective elected officials, officers, employees, agents, and representatives as additional insured.
3. The additional insured coverage for projects for which the Engineer's Estimate is \$1,000,000 or more shall include liability arising out of:
 - a) Ongoing operations performed by you or on your behalf,
 - b) your products,
 - c) your Work, e.g., your completed operations performed by you or on your behalf, or
 - d) premises owned, leased, controlled, or used by you.
4. The additional insured coverage for projects for which the Engineer's Estimate is less than \$1,000,000 shall include liability arising out of:
 - a) Ongoing operations performed by you or on your behalf,
 - b) your products, or
 - c) premises owned, leased, controlled, or used by you.

7-3.5.1.2 Primary and Non-Contributory Coverage. The policy shall be endorsed to provide that the coverage with respect to operations, including the completed operations, if appropriate, of the Named Insured is primary to any insurance or self-insurance of the City and its elected officials, officers, employees, agents and representatives. Further, it shall provide that any insurance maintained by the City and its elected officials, officers, employees, agents and representatives shall be in excess of your insurance and shall not contribute to it.

7-3.5.1.3 Project General Aggregate Limit. The policy or policies shall be endorsed to provide a Designated Construction Project General Aggregate Limit that will apply only to the Work. Only claims payments which arise from the Work shall reduce the Designated Construction Project General Aggregate Limit. The Designated Construction Project General Aggregate Limit shall be in addition to the aggregate limit provided for the products-completed operations hazard.

7-3.5.2 Commercial Automobile Liability Insurance.

7-3.5.2.1 Additional Insured. Unless the policy or policies of Commercial Auto Liability Insurance are written on an ISO form CA 00 01 12 90 or a later version of this form or equivalent form providing coverage at least as broad, the policy shall be endorsed to include the City and its respective elected officials, officers, employees, agents, and representatives as additional insured, with respect to liability arising out of automobiles owned, leased, hired or borrowed by you or on your behalf. This endorsement is limited to the obligations permitted by California Insurance Code §11580.04.

7-3.5.3 Contractors Pollution Liability Insurance Endorsements.

7-3.5.3.1 Additional Insured.

1. The policy or policies shall be endorsed to include as an Insured the City and its respective elected officials, officers, employees, agents, and representatives, with respect to liability arising out of:
 - a) Ongoing operations performed by you or on your behalf,
 - b) your products,
 - c) your work, e.g., your completed operations performed by you or on your behalf, or
 - d) premises owned, leased, controlled, or used by you.

Except that in connection with, collateral to, or affecting any construction contract to which the provisions of subdivision (b) of § 2782 of the California Civil Code apply, this endorsement shall not provide any duty of indemnity coverage for the active negligence of the City and its respective elected officials, officers, employees, agents, and representatives in any case where an agreement to indemnify the City and its respective elected officials, officers, employees, agents, and representatives would be invalid under subdivision (b) of §2782 of the California Civil Code.

2. In any case where a claim or loss encompasses the negligence of the Insured and the active negligence of the City and its respective elected officials, officers, employees, agents, and representatives that are not covered because of California Insurance Code §11580.04, the Insurer's obligation to the City and its respective elected officials, officers, employees, agents, and representatives shall be limited to obligations permitted by California Insurance Code §11580.04.

7-3.5.3.2 Primary and Non-Contributory Coverage. The policy or policies shall be endorsed to provide that the insurance afforded by the Contractors Pollution Liability Insurance policy or policies is primary to any insurance or self-insurance of the City and its

elected officials, officers, employees, agents and representatives with respect to operations including the completed operations of the Named Insured. Any insurance maintained by the City and its elected officials, officers, employees, agents and representatives shall be in excess of your insurance and shall not contribute to it.

7-3.5.3.3 Severability of Interest. For Contractors Pollution Liability Insurance, the policy or policies shall provide that your insurance shall apply separately to each insured against whom claim is made or suit is brought, except with respect to the limits of the insurer's liability and shall provide cross-liability coverage.

7-3.5.4 Contractors Hazardous Transporters Pollution Liability Insurance Endorsements.

7-3.5.4.1 Additional Insured.

1. The policy or policies shall be endorsed to include as an Insured the City and its respective elected officials, officers, employees, agents, and representatives, with respect to liability arising out of:
 - a) Ongoing operations performed by you or on your behalf,
 - b) your products,
 - c) your work, e.g., your completed operations performed by you or on your behalf, or
 - d) premises owned, leased, controlled, or used by you.

Except that in connection with, collateral to, or affecting any construction contract to which the provisions of subdivision (b) of §2782 of the California Civil Code apply, this endorsement shall not provide any duty of indemnity coverage for the active negligence of the City and its respective elected officials, officers, employees, agents, and representatives in any case where an agreement to indemnify the City and its respective elected officials, officers, employees, agents, and representatives would be invalid under subdivision (b) of §2782 of the California Civil Code.

2. In any case where a claim or loss encompasses the negligence of the Insured and the active negligence of the City and its respective elected officials, officers, employees, agents, and representatives that are not covered because of California Insurance Code §11580.04, the insurer's obligation to the City and its respective elected officials, officers, employees, agents, and representatives shall be limited to obligations permitted by California Insurance Code §11580.04.

7-3.5.4.2 Primary and Non-Contributory Coverage. The policy or policies shall be endorsed to provide that the insurance afforded by the Contractors Pollution Liability Insurance policy or policies is primary to any insurance or self-insurance of the City and its

elected officials, officers, employees, agents and representatives with respect to operations including the completed operations of the Named Insured. Any insurance maintained by the City and its elected officials, officers, employees, agents and representatives shall be in excess of your insurance and shall not contribute to it.

7-3.5.4.3 Severability of Interest. For Contractors Hazardous Transporters Pollution Liability Insurance, the policy or policies shall provide that your insurance shall apply separately to each insured against whom claim is made or suit is brought, except with respect to the limits of the insurer's liability and shall provide cross-liability coverage.

7-3.6 Deductibles and Self-Insured Retentions. You shall pay for all deductibles and self-insured retentions. You shall disclose deductibles and self-insured retentions to the City at the time the evidence of insurance is provided.

7-3.7 Reservation of Rights. The City reserves the right, from time to time, to review your insurance coverage, limits, deductibles and self-insured retentions to determine if they are acceptable to the City. The City will reimburse you, without overhead, profit, or any other markup, for the cost of additional premium for any coverage requested by the Engineer but not required by this Contract.

7-3.8 Notice of Changes to Insurance. You shall notify the City 30 Days prior to any material change to the policies of insurance provided under this Contract.

7-3.9 Excess Insurance. Policies providing excess coverage shall follow the form of the primary policy or policies e.g., all endorsements.

7-3.10 Architects and Engineers Professional Insurance (Errors and Omissions Insurance).

1. For Contracts with required engineering services (e.g., Design-Build, preparation of engineered Traffic Control Plans (TCP), and etc.) by you, you shall keep or require all of your employees or Subcontractors, who provide professional engineering services under this contract, Professional Liability coverage with a limit of **\$1,000,000** per claim and **\$2,000,000** annual aggregate in full force and effect.
2. You shall ensure the following:
 - a) The policy retroactive date is on or before the date of commencement of the Project.
 - b) The policy will be maintained in force for a period of 3 years after completion of the Project or termination of this Contract, whichever occurs last. You agree that for the time period specified above, there will be no changes or endorsements to the policy that affect the specified coverage.

3. If professional engineering services are to be provided solely by the Subcontractor, you shall:
 - a) Certify this to the City in writing and
 - b) Agree in writing to require the Subcontractor to procure Professional Liability coverage in accordance with the requirements set forth above.

7-4 NOT USED. To the "GREENBOOK", DELETE in its entirety and SUBSTITUTE with the following:

7-4 WORKERS' COMPENSATION INSURANCE AND EMPLOYERS LIABILITY INSURANCE.

1. In accordance with the provisions of §3700 of the California Labor Code, you shall provide at your expense Workers' Compensation Insurance and Employers Liability Insurance to protect you against all claims under applicable state workers compensation laws. The City, its elected officials, and employees will not be responsible for any claims in law or equity occasioned by your failure to comply with the requirements of this section.

2. Limits for this insurance shall be not less than the following:

<u>Workers' Compensation</u>	<u>Statutory Employers Liability</u>
Bodily Injury by Accident	\$1,000,000 each accident
Bodily Injury by Disease	\$1,000,000 each employee
Bodily Injury by Disease	\$1,000,000 policy limit

3. By signing and returning the Contract you certify that you are aware of the provisions of §3700 of the Labor Code which requires every employer to be insured against liability for worker's compensation or to undertake self-insurance in accordance with the provisions of that code and you shall comply with such provisions before commencing the Work as required by §1861 of the California Labor Code.

7-4.1. Waiver of Subrogation. The policy or policies shall be endorsed to provide that the insurer will waive all rights of subrogation against the City and its respective elected officials, officers, employees, agents, and representatives for losses paid under the terms of the policy or policies and which arise from Work performed by the Named Insured for the City.

7-8.1 GENERAL. To the "WHITEBOOK", ADD the following:

2. Use a self-loading motorized street sweeper equipped with a functional water spray system for this project.

7-8.6 Water Pollution Control. To the "WHITEBOOK", ADD the following:

6. Based on a preliminary assessment by the City, this Contract is subject to WPCP.

7-8.6.5.5 Chlorination Discharge Requirements. You shall discharge chlorinated water used for testing and acceptance of new mains to the sewer system as shown (after de-chlorination), when provided, on the "Chlorination Discharge Locations" sheet of the Plans at no cost to you. When discharging to the sewer system, you shall submit to the Resident Engineer a log of actual discharged water quantities, dates and locations. Resident Engineer will submit to PUC who will charge the project WBS No. When discharging the chlorinated water used for testing of new mains to surface water or storm drains, you shall comply with Section 7-8.6.5 Hydrostatic Discharge Requirements.

7-20 ELECTRONIC COMMUNICATION. To the "WHITEBOOK", ADD the following:

2. Virtual Project Manager shall be used on this Contract.

7-21.1 General. To the "WHITEBOOK", item 3, DELETE in its entirety and SUBSTITUTE with the following:

3. During the construction phase of projects, the minimum waste management reduction goal is 90% of the inert material (a material not subject to decomposition such as concrete, asphalt, brick, rock, block, dirt, metal, glass, and etc.) and 65% of the remaining project waste. You shall provide appropriate documentation, including a Waste Management Form attached as an appendix, and evidence of recycling and reuse of materials to meet the waste reduction goals specified.

SECTION 9 - MEASUREMENT AND PAYMENT

ADD:

9-3.7 Compensation Adjustments for Price Index Fluctuations. To the "WHITEBOOK", ADD the following:

5. This Contract is not subject to the provisions of The "WHITEBOOK" for Compensation Adjustments for Price Index Fluctuations for paving asphalt.

SECTION 203 - BITUMINOUS MATERIALS

203-3.4.4 Rubber Polymer Modified Slurry (RPMS). To the "WHITEBOOK", ADD the following:

1. RPMS shall be used on this Contract.

SECTION 209 – PRESSURE PIPE

209 PRESSURE PIPE. To the “WHITEBOOK”, ADD the following:

2. PVC products, specifically type C900 and C905, as manufactured or distributed by J-M Manufacturing Company or JM Eagle shall not be used on the Contract for pressurized pipe.

SECTION 217 – BEDDING AND BACKFILL MATERIALS

217-2.2 Stones, Boulders, and Broken Concrete. To the “GREENBOOK”, Table 217-2.2, DELETE in its entirety and SUBSTITUTE with the following:

TABLE 217-2.2

Zone	Zone Limits	Maximum Size (greatest dimension)	Backfill Requirements in Addition to 217-2.1
Street or Surface Zone	From ground surface to 12" (300 mm) below pavement subgrade or ground surface	2.5" (63 mm)	As required by the Plans or Special Provisions.
Street or Surface Zone Backfill of Tunnels beneath Concrete Flatwork		Sand	Sand equivalent of not less than 30.
Trench Zone	From 12" (300 mm) below pavement subgrade or ground surface to 12" (300 mm) above top of pipe or box	6" (150 mm)	
Deep Trench Zone (Trenches 3' (0.9 m) wide or wider)	From 60" (1.5 m) below finished surface to 12" (300 mm) above top of pipe or box	Rocks up to 12" (300 mm) excavated from trench may be placed as backfill	
Pipe Zone	From 12" (300 mm) above top of pipe or box to 6" (150 mm) below bottom of pipe or box exterior	2.5" (63 mm)	Sand equivalent of not less than 30 or a coefficient of permeability greater than 1-½ inches/hour (35 mm per hour).
Overexcavation	Backfill more than 6" (150 mm) below bottom of pipe or box exterior	6" (150 mm)	Sand equivalent of not less than 30 or a coefficient of permeability greater than 1-½ inches/hour (35 mm per hour). Trench backfill slurry (100-E-100) per 201-1 may also be used.

SECTION 302 – ROADWAY SURFACING

302-4.12.2.1 General. To the “WHITEBOOK”, ADD the following:

3. When Type I is to be applied over Type II or Type III, corrective action in accordance with 302-4.11.1.2, “Reduction in Payment Based on WTAT” such as reductions in payment, non-payment, or removal of Type II or Type III material not meeting specifications as directed by the Engineer shall be executed prior to the application of the Type I material.

302-4.12.4 Measurement and Payment. To the "WHITEBOOK", item 2, Bid Description Table, ADD the following:

BID DESCRIPTION	UNIT
Rubber Polymer Modified Slurry (RPMS) Type I Over Type II and Striping	SF

302-7.4 Payment. To the "WHITEBOOK", item 1, last sentence, DELETE in its entirety and SUBSTITUTE with the following:

Payment shall not be made for additional fabric for overlapped areas.

SECTION 304 –METAL FABRICATION AND CONSTRUCTION

304-5 PAYMENT. To the "WHITEBOOK", REVISE section "304-5" to "304-6".

SECTION 306 – OPEN TRENCH CONDUIT CONSTRUCTION

306-1 GENERAL. To the "GREENBOOK", ADD the following:

Build the Project in accordance with the water high-lining phasing shown on the Plans and in phases as follows:

GROUP 764: The High-lining Phase limits below in this project are approximate:

1. Phase I:
 - SITE 1, SITE 2, SITE 3 and SITE 5: Along various streets, see project plan sheets per each site location.
 - SITE 4: Along Silver Gate Avenue from Cul-De-Sac through Silver Gate Place.
2. Phase II:
 - SITE 4: Along Cedarbrae Lane from STA 1+00 to STA 1+56.34
3. Phase III:
 - SITE 4: Along Cedarbrae Lane from STA 1+56.34 through Silver Gate Avenue.
4. Phase IV:
 - SITE 4: Along Silver Gate Avenue from Silver Gate Place through Via Flores.

GROUP 821: The High-lining Phase limits below in this project are approximate:

1. Phase I: Along Gage Drive from Gage Place through Jennings Street and along Dupont Street from Albion Street through Gage Drive.

2. Phase II: Along Silver Gate Avenue from Warner Street through Charles Street and along Wilcox Street from Cul-De-Sac through Silver Gate Avenue.
3. Phase III: Along Dupont Street, Warner Street and Duddley Street from Silver Gate Avenue through Catalina Boulevard.
4. Phase IV: Along Gage Drive from Cul-De-Sac through Dupont Street.

306-7.8.2.1 General. To the "WHITEBOOK", item 2, ADD the following:

- a) Specified test pressure for Class 235 pipe shall be 150 psi.
- b) Specified test pressure for Class 305 pipe shall be 200 psi.

306-15.2 Shoring and Bracing. To the "WHITEBOOK", DELETE in its entirety and SUBSTITUTE with the following:

1. The Bid item for "Trench Shoring" shall include full compensation for furnishing, installing, maintaining, and removing all sheeting, shoring, or bracing for any conditions encountered that require shoring including the preparation of engineered Shoring Plans in accordance with 7-10.4.2.2, "Shoring Plan". No additional payment shall be made.

SECTION 500 – PIPELINE, MANHOLE, AND STRUCTURE REHABILITATION

500-1.1.2.1 Initial Submittals. To the "WHITEBOOK", ADD the following:

4. Within 3 Working Days of the Bid opening date, the 3 apparent low bidders shall submit the following:
 - a) Contractor's Experience; past project documentation
 - b) Manufacturer Certification
 - c) Authorize Installer Certificates

ADD:

500-1.1.6.1 Order of Work for Rehabilitation Installation.

1. Rehabilitation shall be performed in the following order of Work:
 - a) First: Rehabilitation of Sewer Main, including sampling and testing.
 - b) Second: Installation of Sewer Lateral Connections and End Seals.
 - c) Third: Rehabilitation of Sewer Laterals, including sampling and testing.
2. You shall plan and schedule Work accordingly. Additional payment for demobilization or mobilization and additional Working Days shall not be granted for delays due to the order of rehabilitation Work.

500-1.6.6

Payment. To the "WHITEBOOK", DELETE in its entirety and SUBSTITUTE with the following:

1. The payment for the service lateral rehabilitation Work of existing sewer laterals, existing cast iron sewer laterals, cleanout installations at the access point, and manual excavations for cleanout pits shall be included in the following Bid Items:

Service Lateral Rehabilitation with Cleanout up to 7 Feet in Depth
Service Lateral Rehabilitation with Cleanout Greater than 7 Feet in Depth
Service Lateral Rehabilitation with Manually Excavated Cleanout up to 7 Feet in Depth
Service Lateral Rehabilitation with Manually Excavated Cleanout Greater than 7 Feet in Depth
Service Lateral Rehabilitation of Cast Iron Lateral with Cleanout Greater than 7 Feet in Depth
Service Lateral Rehabilitation of Cast Iron Lateral with Cleanout up to 7 Feet in Depth
Service Lateral Rehabilitation of Cast Iron Lateral with Manually Excavated Cleanout Greater than 7 Feet in Depth
Service Lateral Rehabilitation of Cast Iron Lateral with Manually Excavated Cleanout up to 7 Feet in Depth

These Bid items shall include all necessary labor, materials, and equipment in order to clean, repair, and line the Sewer Lateral.

2. The point repair Work for sewer laterals shall be in accordance with 500-1.2, "Pipeline Point Repair/Replacement" and shall be included in the Bid item for each "Point Repair for Existing Sewer Lateral". Measurement shall be made at the pipe and shall be based on the length of pipe repaired. You shall be paid for 1 point repair for each repair 8 ft (2.43 m) or less in length. This payment shall include all necessary labor, materials, and equipment to clean, repair, excavate, and inspect the Point Repair.
3. The payment for cleaning and video inspection for rehabilitated laterals shall be paid in accordance with 306-18.7, "Payment".

500-2.4.6

Primer and Lining Materials. To the "WHITEBOOK", DELETE in its entirety and SUBSTITUTE with the following:

ADD:

500-2.4.6

Chemical Resistance Test (Pickle Jar Test).

1. Epoxy Lining Systems, Polyurethane and Epoxy Protective Lining Systems shall meet the requirements of 211-2, "Chemical Resistance Test (Pickle Jar Test)".

Proof of meeting these requirements shall be provided to the Engineer for approval at least 15 Days prior to commencement of Work.

2. The epoxy primer materials for the polyurethane lining system shall be 100% solids.
3. The epoxy materials for the epoxy lining system shall be 100% solids.

500-2.4.7 Lining Application. To the "WHITEBOOK", DELETE in its entirety.

500-2.4.8 Test. To the "WHITEBOOK", DELETE in its entirety.

500-2.4.10 Applicable Standards. To the "WHITEBOOK", DELETE in its entirety.

SECTION 900 – MATERIALS

900-1.2 Payment. To the "WHITEBOOK", item 2, DELETE in its entirety and SUBSTITUTE with the following:

2. The Payment for your high-lining materials (fittings, valves, and hardware), including delivery and unloading, shall be paid for under the linear foot Bid item "Furnished Materials for Contractor High-line Work".

SECTION 901 – INSTALLATION AND CONNECTION

901-2.5 Payment. To the "WHITEBOOK", item 3, DELETE in its entirety and SUBSTITUTE with the following:

3. Traffic control, saw cutting the trench area, trench caps, and other spot repairs in the vicinity of the disturbed area at each restored connection shall be included in the square foot Bid item for "Pavement Restoration for Final Connection". Asphalt overlay and slurry seal Work shall be paid for under separate Bid items.

EQUAL OPPORTUNITY CONTRACTING PROGRAM (EOCP) SECTION A – GENERAL REQUIREMENTS

4.1 Nondiscrimination in Contracting Ordinance. To the "WHITEBOOK", subsection 4.1.1, paragraph (2), sentence (1), DELETE in its entirety and SUBSTITUTE with the following:

You shall not discriminate on the basis of race, gender, gender expression, gender identity, religion, national origin, ethnicity, sexual orientation, age, or disability in the solicitation, selection, hiring, or treatment of subcontractors, vendors, or suppliers.

END OF SUPPLEMENTARY SPECIAL PROVISIONS (SSP)

SUPPLEMENTARY SPECIAL PROVISIONS

APPENDICES

APPENDIX A

ADDENDUM TO A MITIGATED NEGATIVE DECLARATION (AMND) AND NOTICE OF DETERMINATION (NOD)



ADDENDUM TO A MITIGATED NEGATIVE DECLARATION

THE CITY OF SAN DIEGO

Project No. 509234
Addendum to MND No. 255100
SCH No. 2011091045

SUBJECT: Sewer & AC Water Group Job 764 and 821

I. PROJECT DESCRIPTION

Sewer and AC Water Group 764 and 821 is a part of the City of San Diego's on-going Sewer Main and Water Main Replacement Program. The existing sewer and water lines are old, and are nearing the end of their service life. Construction of the project will reduce maintenance requirements, correct hydraulic deficiencies, improve reliability and accessibility, and bring the sewer and water main systems up to current design standards.

The purpose of the Sewer and AC Water Group 764 and 821 Project is to improve the existing water and sewer systems, which will benefit the Point Loma community. The affected roadways/rights-of way are as follows:

Location of Improvements:

SEWER & AC WATER GROUP JOB 764

Sewer Infrastructure Improvements	Water Infrastructure Improvements	Sewer Infrastructure Rehabilitation
Fenelon St. (East and West of the Intersection of Carleton St.)	Fenelon St. (West of Clove St.)	----
Clove St. (South of intersection with Fenelon St. to intersection with Emerson St.)	Clove St. (South of intersection with Fenelon St. to intersection with Emerson St.)	----
----	----	Alleyway (Between Clove St. and Plum St.)
----	----	Ave. de Portugal (Small segment west of Plum St.)
Moana Dr. (Between Lomaland Dr. and John St.)	Moana Dr. (Between Lomaland Dr. and John St.)	----

Sewer Infrastructure Improvements	Water Infrastructure Improvements	Sewer Infrastructure Rehabilitation
Silver Gate Ave. (Border with naval base to before Pio Pico St.)	Silver Gate Ave. (Border with naval base to Silver Gate Pl.)	----
Silver Gate Pl. (From intersection with Silver Gate Ave. midway through block)	Silver Gate Pl. (From intersection with Silver Gate Ave. - entire block)	----
Cedarbrae Lane (Between intersection with Catalina Blvd. to intersection with Silver Gate Ave.)	Cedarbrae Lane (Between intersection with Catalina Blvd. to intersection with Silver Gate Ave.)	----
----	----	Trudy Lane (From end of cul-de-sac to Cedarbrae Lane)
----	----	San Gorgonio St. (South of intersection with Kellogg St.)
----	Kellogg St. (From intersection with San Gorgonio St. to San Elijo St.)	Kellogg St. (From intersection with San Gorgonio St. to San Elijo St.)
San Fernando St. (South of intersection with Kellogg St. to naval base border)	San Fernando St. (South of intersection with Kellogg St. to naval base border)	----
----	San Elijo St. (South of intersection with Kellogg St. to naval base border)	----

SEWER & AC WATER GROUP JOB 821

Sewer Infrastructure Improvements	Water Infrastructure Improvements	Sewer Infrastructure Rehabilitation
----	Dudley St. (From intersection with Catalina Blvd. to intersection with Silver Gate Ave.)	----
----	Warner St. (From intersection with Catalina Blvd. to intersection with Silver Gate Ave.)	----
----	Dupont St. (From intersection with Catalina Blvd. to intersection with Silver Gate Ave.)	----
----	Dupont St. (From intersection with Albion St. to intersection with Gage Ave.)	----
Dupont St. (From intersection with Silver Gate Ave. to intersection with Gage Ave.)	----	----

Sewer Infrastructure Improvements	Water Infrastructure Improvements	Sewer Infrastructure Rehabilitation
Gage Dive (From southern end of roadway to intersection with Jennings St.)	Gage Dive (From southern end of roadway to intersection with Jennings St.)	----
----	Gage Pl. (Entire St.)	----
Three Unnamed Alleyways (West of Silver Gate Ave., between Pio Pico St. and Dudley St.)	----	----
Two Unnamed Alleyways (West of Silver Gate Ave., between Charles St. and Jennings St.)	----	----
Wilcox St. (West of intersection with Silver Gate Ave. to terminus of St.)	----	----
Albion St. (North of intersection with Jennings St. to Talbot St.)	----	----
Albion St. (North of intersection with Dupont St. to Charles St.)	----	----
----	----	Unnamed Alleyway (From intersection with Charles St. to intersection with Jennings St.)

This will be accomplished by replacing 9,817 linear feet (LF) of existing 8 inch water main lines with new 8 inch water main lines within existing alignments at depths of 3-5 feet below existing grade. It should be noted portions of this line will be deeper are than existing trenching depth. Additionally, 3,625 linear feet (LF) of 8 inch water main lines are proposed to be installed within new alignments of depths ranging from 3-5 feet.

The project would also “replace-in-place” approximately 9,817 linear feet (LF) of existing 8 inch cast-iron (CI) water pipes with new 8 inch polyvinyl chloride (PVC) piping. This will be placed within existing alignments at current grade levels or deeper. It should be noted that 3,625 linear feet (LF) will be placed within new alignments at depths ranging from 3-5 feet below grade.

The project would also replace 5,934 linear feet (LF) of existing 8 inch vitrified clay (VC) sewer main lines with new 8 inch polyvinyl chloride (PVC) piping within existing alignments at depths of 3-5 feet below existing grade. It should be noted portions of this line will be deeper are than existing trenching depth. Additionally, 6,531 linear feet (LF) of 8 inch polyvinyl chloride (PVC) sewer main lines are proposed to be installed within new alignments of depths ranging from 4-22.5 feet. Furthermore, 2,730 linear feet (LF) of existing sewer pipe will be rehabilitated via tunneling methodology.

The project would also include the abandonment of 364 lineal feet (LF) of existing sewer main lines. Inclusive of this portion of the project, existing manholes and areas with exposed pipes will be removed.

Pipeline abandonment activities will have minimum surface/subsurface disturbance. The lines would be left in place, capped at both ends and slurry filled per engineering design standards. All abandonments would occur within existing public right of way/roadways.

Other components of the project will include the installation of curb ramps, laterals, cleanouts, water meters, water boxes, slurry seal, provide pavement overlay, rehabilitate existing manholes and provide St. resurfacing where applicable. All work will occur either within previously disturbed areas or areas below grade. As such, there would be no impacts to sensitive biological resources.

II. ENVIRONMENTAL SETTING

The project would occur within the developed public right-of-way and existing public utility easements located within the Peninsula Community Plan area. Surrounding land uses include existing single-family residential, and public/semi-public land uses (Point Loma Nazarene University and NSC San Diego (Naval Complex), Point Loma Annex).

III. PROJECT BACKGROUND

A Citywide Pipelines Projects Mitigated Negative Declaration (MND) No. 255100 was prepared by the City of San Diego's Development Services Department (DSD) and was certified by the City Council on November 30, 2011 (Resolution No. 307122). The Citywide Pipelines Projects MND provides for the inclusion of subsequent pipeline projects that are located within the public right-of-way and would not result in any direct impacts to sensitive biological resources.

Therefore, in accordance with Section 15164 of the State CEQA Guidelines this addendum has been prepared. Additionally, in accordance with requirements in Section 128.0306 of the San Diego Municipal Code, and State CEQA Guidelines Section 15064(c), no public review period is required for this addendum.

Archaeological Resources

The Citywide Pipelines Project MND No. 255100 concluded that pipeline projects located within the public right-of-way and city easements could result in significant environmental impacts relating to archaeological resources, which included mitigation to reduce impacts to archaeological resources to below a level of significance. The Sewer & AC Water Group 764 and 821 project area includes the excavation of previously undisturbed soil which has the potential to contain sensitive archaeological resources.

To reduce potential archaeological resource impacts to below a level of significance, excavation within previously undisturbed soil, for either new trench alignments and/or for replacement of pipelines within the same trench alignment occurring at a deeper depth than the previously existing pipeline, would be monitored by a qualified archaeologist or archaeological monitor and Native American monitor. Any significant archaeological resources encountered would be recovered and curated in accordance with the mitigation monitoring and Reporting Program (MMRP) detailed in Section VI.

Paleontological Resources

The Citywide Pipelines Project MND No. 255100 analyzed paleontological resources in relation to pipeline projects, which included mitigation to reduce impacts to paleontological resources to below a level of significance.

Sewer & AC Water Group 764

The portion of the project is primarily underlain with the highly sensitive Linda Vista Formation (QIn) and moderately sensitive Cabrillo Formation (Kcs) within proposed improvement areas.

Sewer & AC Water Group 821

The portion of the project is primarily underlain with the highly sensitive Linda Vista Formation (QIn) within proposed improvement areas.

Based on the sensitivity of the affected formations and proposed 22'-6" new trenching excavation depth for Sewer & AC Water Group 764 and proposed 20' new trenching excavation depth for Sewer & AC Water Group 821, it was determined there could be potentially significant impacts to fossil resources.

To reduce potential impacts to below a level of significance for the project, excavation within previously undisturbed formations at a depth of 10 or more feet, for either new trench alignments and/or for replacement of pipelines within the same trench alignment occurring at a deeper depth than the previously existing pipeline, would be monitored by a qualified paleontologist or paleontological monitor. Any significant paleontological resources encountered would be recovered and curated in accordance with the mitigation monitoring and Reporting Program (MMRP) detailed in Section VI.

IV. ENVIRONMENTAL DETERMINATION

The City previously prepared and certified the **Mitigated Negative Declaration (No. 255100 / SCH No. 2011091045)**. Based on all available information in light of the entire record, the analysis in this Addendum, and pursuant to Section 15162 of the State CEQA Guidelines, the City has determined the following:

- There are no substantial changes proposed in the project which will require major revisions of the previous environmental document due to the involvement of new significant environmental effects or a substantial increase in the severity of previously identified significant effects;
- Substantial changes have not occurred with respect to the circumstances under which the project is undertaken which will require major revisions of the previous environmental document due to the involvement of new significant environmental effects or a substantial increase in the severity of previously identified significant effects; or
- There is no new information of substantial importance, which was not known and could not have been known with the exercise of reasonable diligence at the time the previous environmental document was certified as complete or was adopted, shows any of the following:
 - a. The project will have one or more significant effects not discussed in the previous

environmental document;

- b. Significant effects previously examined will be substantially more severe than shown in the previous environmental document;
- c. Mitigation measures or alternatives previously found not to be feasible would in fact be feasible, and would substantially reduce one or more significant effects of the project, but the project proponents decline to adopt the mitigation measure or alternative; or
- d. Mitigation measures or alternatives which are considerably different from those analyzed in the previous environmental would substantially reduce one or more significant effects on the environment, but the project proponents decline to adopt the mitigation measure or alternative.

Based upon a review of the current project, none of the situations described in Sections 15162 and 15164 of the State CEQA Guidelines apply. No changes in circumstances have occurred, and no new information of substantial importance has manifested, which would result in new significant or substantially increased adverse impacts as a result of the project. Therefore, this Addendum has been prepared in accordance with Section 15164 of the CEQA State Guidelines. Public review of this Addendum is not required per CEQA.

V. IMPACT ANALYSIS

The subsequent impact analysis is to demonstrate that environmental impacts associated with the project are consistent with the previously certified MND. The following includes the project-specific environmental review pursuant to the CEQA. The analysis in this document evaluates the adequacy of the MND relative to the project.

Archaeological Resources

The Citywide Pipelines Project MND No. 255100 concluded that pipeline projects located within the public right-of-way and city easements could result in significant environmental impacts relating to archaeological resources, which included mitigation to reduce impacts to archaeological resources to below a level of significance. The Water Group 939 project area would include excavation of previously undisturbed soil which has the potential to contain sensitive archaeological resources.

To reduce potential archaeological resource impacts to below a level of significance, excavation within previously undisturbed soil, for either new trench alignments and/or for replacement of pipelines within the same trench alignment occurring at a deeper depth than the previously existing pipeline, would be monitored by a qualified archaeologist or archaeological monitor and Native American monitor. Any significant archaeological resources encountered would be recovered and curated in accordance with the mitigation monitoring and Reporting Program (MMRP) detailed in Section VI.

Paleontological Resources

The Citywide Pipelines Project MND No. 255100 analyzed paleontological resources in relation to pipeline projects, which included mitigation to reduce impacts to paleontological resources to below a level of significance.

Sewer & AC Water Group 764

The portion of the project is primarily underlain with the highly sensitive Linda Vista Formation (QIn) and moderately sensitive Cabrillo Formation (Kcs) within proposed improvement areas.

Sewer & AC Water Group 821

The portion of the project is primarily underlain with the highly sensitive Linda Vista Formation (QIn) within proposed improvement areas.

Based on the sensitivity of the affected formations and proposed 22'-6" new trenching excavation depth for Sewer & AC Water Group 764 and proposed 20' new trenching excavation depth for Sewer & AC Water Group 821, it was determined there could be potentially significant impacts to fossil resources.

To reduce potential impacts to below a level of significance for the project, excavation within previously undisturbed formations at a depth of 10 or more feet, for either new trench alignments and/or for replacement of pipelines within the same trench alignment occurring at a deeper depth than the previously existing pipeline, would be monitored by a qualified paleontologist or paleontological monitor. Any significant paleontological resources encountered would be recovered and curated in accordance with the mitigation monitoring and Reporting Program (MMRP) detailed in Section VI.

VI. MITIGATION, MONITORING AND REPORTING PROGRAM

GENERAL REQUIREMENTS

1. Prior to issuance of a Notice to Proceed (NTP), the Assistant Deputy Director (ADD) Environmental Designee of the Entitlements Division shall verify that Mitigation Measures for **HISTORICAL RESOURCES (ARCHAEOLOGY)** and **PALEONTOLOGICAL RESOURCES** have been included in entirety on the submitted construction documents and contract specifications, and included under the heading, "Environmental Mitigation Requirements." In addition, the requirements for a Preconstruction Meeting shall be noted on all construction documents.
2. Prior to the commencement of work, a Preconstruction Meeting (Pre-con) shall be conducted and include the City of San Diego's Mitigation Monitoring Coordination (MMC) Section, Resident Engineer, Building Inspector, Project Consultant (**Archaeologist, Paleontologist**) Applicant and other parties of interest.
3. Evidence of compliance with other permitting authorities is required, if applicable. Evidence shall include either copies of permits issued, letters of resolution issued by the Responsible Agency documenting compliance, or other evidence documenting compliance and deemed acceptable by the ADD Environmental Designee.

HISTORICAL RESOURCES (ARCHAEOLOGY)

I. Prior to Permit Issuance or Bid Opening/Bid Award

- A. Entitlements Plan Check

1. Prior to permit issuance or Bid Opening/Bid Award, whichever is applicable, the Assistant Deputy Director (ADD) Environmental designee shall verify that the requirements for Archaeological Monitoring and Native American monitoring have been noted on the applicable construction documents through the plan check process.
- B. Letters of Qualification have been submitted to ADD
1. Prior to Bid Award, the applicant shall submit a letter of verification to Mitigation Monitoring Coordination (MMC) identifying the Principal Investigator (PI) for the project and the names of all persons involved in the archaeological monitoring program, as defined in the City of San Diego Historical Resources Guidelines (HRG). If applicable, individuals involved in the archaeological monitoring program must have completed the 40-hour HAZWOPER training with certification documentation.
 2. MMC will provide a letter to the applicant confirming the qualifications of the PI and all persons involved in the archaeological monitoring of the project meet the qualifications established in the HRG.
 3. Prior to the start of work, the applicant must obtain written approval from MMC for any personnel changes associated with the monitoring program.

II. Prior to Start of Construction

A. Verification of Records Search

1. The PI shall provide verification to MMC that a site specific records search (1/4 mile radius) has been completed. Verification includes, but is not limited to a copy of a confirmation letter from South Coastal Information Center, or, if the search was in-house, a letter of verification from the PI stating that the search was completed.
2. The letter shall introduce any pertinent information concerning expectations and probabilities of discovery during trenching and/or grading activities.
3. The PI may submit a detailed letter to MMC requesting a reduction to the ¼ mile radius.

B. PI Shall Attend Precon Meetings

1. Prior to beginning any work that requires monitoring; the Applicant shall arrange a Precon Meeting that shall include the PI, Native American consultant/monitor (where Native American resources may be impacted), Construction Manager (CM) and/or Grading Contractor, Resident Engineer (RE), Building Inspector (BI), if appropriate, and MMC. The qualified Archaeologist and Native American Monitor shall attend any grading/excavation related Precon Meetings to make comments and/or suggestions concerning the Archaeological Monitoring program with the Construction Manager and/or Grading Contractor.
 - a. If the PI is unable to attend the Precon Meeting, the Applicant shall schedule a focused Precon Meeting with MMC, the PI, RE, CM or BI, if appropriate, prior to the start of any work that requires monitoring.

2. Acknowledgement of Responsibility for Curation (CIP or Other Public Projects)
The applicant shall submit a letter to MMC acknowledging their responsibility for the cost of curation associated with all phases of the archaeological monitoring program.
3. Identify Areas to be Monitored
 - a. Prior to the start of any work that requires monitoring, the PI shall submit an Archaeological Monitoring Exhibit (AME) (with verification that the AME has been reviewed and approved by the Native American consultant/monitor when Native American resources may be impacted) based on the appropriate construction documents (reduced to 11x17) to MMC identifying the areas to be monitored including the delineation of grading/excavation limits.
 - b. The AME shall be based on the results of a site specific records search as well as information regarding the age of existing pipelines, laterals and associated appurtenances and/or any known soil conditions (native or formation).
 - c. MMC shall notify the PI that the AME has been approved.
4. When Monitoring Will Occur
 - a. Prior to the start of any work, the PI shall also submit a construction schedule to MMC through the RE indicating when and where monitoring will occur.
 - b. The PI may submit a detailed letter to MMC prior to the start of work or during construction requesting a modification to the monitoring program. This request shall be based on relevant information such as review of final construction documents which indicate conditions such as age of existing pipe to be replaced at depth of excavation and/or site graded to bedrock, etc., which may reduce or increase the potential for resources to be present.
5. Approval of AME and Construction Schedule
After approval of the AME by MMC, the PI shall submit to MMC written authorization of the AME and Construction Schedule from the CM.

III. During Construction

- A. Monitor Shall be Present During Grading/Excavation/Trenching
 1. The Archaeological Monitor shall be present full-time during all soil disturbing and grading/excavation/trenching activities which could result in impacts to archaeological resources as identified on the AME. **The Construction Manager is responsible for notifying the RE, PI, and MMC of changes to any construction activities such as in the case of a potential safety concern within the area being monitored. In certain circumstances OSHA safety requirements may necessitate modification of the AME.**
 2. The Native American consultant/monitor shall determine the extent of their presence during soil disturbing and grading/excavation/trenching activities based on

the AME and provide that information to the PI and MMC. If prehistoric resources are encountered during the Native American consultant/monitor's absence, work shall stop and the Discovery Notification Process detailed in Section III.B-C and IV.A-D shall commence.

3. The PI may submit a detailed letter to MMC during construction requesting a modification to the monitoring program when a field condition such as modern disturbance post-dating the previous grading/trenching activities, presence of fossil formations, or when native soils are encountered that may reduce or increase the potential for resources to be present.
4. The archaeological and Native American consultant/monitor shall document field activity via the Consultant Site Visit Record (CSV). The CSV's shall be faxed by the CM to the RE the first day of monitoring, the last day of monitoring, monthly (**Notification of Monitoring Completion**), and in the case of ANY discoveries. The RE shall forward copies to MMC.

B. Discovery Notification Process

1. In the event of a discovery, the Archaeological Monitor shall direct the contractor to temporarily divert all soil disturbing activities, including but not limited to digging, trenching, excavating or grading activities in the area of discovery and in the area reasonably suspected to overlay adjacent resources and immediately notify the RE or BI, as appropriate.
2. The Monitor shall immediately notify the PI (unless Monitor is the PI) of the discovery.
3. The PI shall immediately notify MMC by phone of the discovery, and shall also submit written documentation to MMC within 24 hours by fax or email with photos of the resource in context, if possible.
4. No soil shall be exported off-site until a determination can be made regarding the significance of the resource specifically if Native American resources are encountered.

C. Determination of Significance

1. The PI and Native American consultant/monitor, where Native American resources are discovered shall evaluate the significance of the resource. If Human Remains are involved, follow protocol in Section IV below.
 - a. The PI shall immediately notify MMC by phone to discuss significance determination and shall also submit a letter to MMC indicating whether additional mitigation is required.
 - b. If the resource is significant, the PI shall submit an Archaeological Data Recovery Program (ADRP) and obtain written approval of the program from MMC, CM and RE. ADRP and any mitigation must be approved by MMC, RE and/or CM before ground disturbing activities in the area of discovery will be allowed to resume.

Note: If a unique archaeological site is also an historical resource as defined in CEQA Section 15064.5, then the limits on the amount(s) that a project applicant may be required to pay to cover mitigation costs as indicated in CEQA Section 21083.2 shall not apply.

(1). Note: For pipeline trenching and other linear projects in the public Right-of-Way, the PI shall implement the Discovery Process for Pipeline Trenching projects identified below under "D."

c. If the resource is not significant, the PI shall submit a letter to MMC indicating that artifacts will be collected, curated, and documented in the Final Monitoring Report. The letter shall also indicate that that no further work is required.

(1). Note: For Pipeline Trenching and other linear projects in the public Right-of-Way, if the deposit is limited in size, both in length and depth; the information value is limited and is not associated with any other resource; and there are no unique features/artifacts associated with the deposit, the discovery should be considered not significant.

(2). Note, for Pipeline Trenching and other linear projects in the public Right-of-Way, if significance cannot be determined, the Final Monitoring Report and Site Record (DPR Form 523A/B) shall identify the discovery as Potentially Significant.

D. Discovery Process for Significant Resources - Pipeline Trenching and other Linear Projects in the Public Right-of-Way

The following procedure constitutes adequate mitigation of a significant discovery encountered during pipeline trenching activities or for other linear project types within the Public Right-of-Way including but not limited to excavation for jacking pits, receiving pits, laterals, and manholes to reduce impacts to below a level of significance:

1. Procedures for documentation, curation and reporting

a. One hundred percent of the artifacts within the trench alignment and width shall be documented in-situ, to include photographic records, plan view of the trench and profiles of side walls, recovered, photographed after cleaning and analyzed and curated. The remainder of the deposit within the limits of excavation (trench walls) shall be left intact.

b. The PI shall prepare a Draft Monitoring Report and submit to MMC via the RE as indicated in Section VI-A.

c. The PI shall be responsible for recording (on the appropriate State of California Department of Park and Recreation forms-DPR 523 A/B) the resource(s) encountered during the Archaeological Monitoring Program in accordance with the City's Historical Resources Guidelines. The DPR forms shall be submitted to the South Coastal Information Center for either a Primary Record or SDI Number and included in the Final Monitoring Report.

- d. The Final Monitoring Report shall include a recommendation for monitoring of any future work in the vicinity of the resource.

IV. Discovery of Human Remains

If human remains are discovered, work shall halt in that area and no soil shall be exported off-site until a determination can be made regarding the provenance of the human remains; and the following procedures as set forth in CEQA Section 15064.5(e), the California Public Resources Code (Sec. 5097.98) and State Health and Safety Code (Sec. 7050.5) shall be undertaken:

A. Notification

1. Archaeological Monitor shall notify the RE or BI as appropriate, MMC, and the PI, if the Monitor is not qualified as a PI. MMC will notify the appropriate Senior Planner in the Environmental Analysis Section (EAS) of the Development Services Department to assist with the discovery notification process.
2. The PI shall notify the Medical Examiner after consultation with the RE, either in person or via telephone.

B. Isolate discovery site

1. Work shall be directed away from the location of the discovery and any nearby area reasonably suspected to overlay adjacent human remains until a determination can be made by the Medical Examiner in consultation with the PI concerning the provenience of the remains.
2. The Medical Examiner, in consultation with the PI, will determine the need for a field examination to determine the provenience.
3. If a field examination is not warranted, the Medical Examiner will determine with input from the PI, if the remains are or are most likely to be of Native American origin.

C. If Human Remains **ARE** determined to be Native American

1. The Medical Examiner will notify the Native American Heritage Commission (NAHC) within 24 hours. By law, **ONLY** the Medical Examiner can make this call.
2. NAHC will immediately identify the person or persons determined to be the Most Likely Descendent (MLD) and provide contact information.
3. The MLD will contact the PI within 24 hours or sooner after the Medical Examiner has completed coordination, to begin the consultation process in accordance with CEQA Section 15064.5(e), the California Public Resources and Health & Safety Codes.
4. The MLD will have 48 hours to make recommendations to the property owner or representative, for the treatment or disposition with proper dignity, of the human remains and associated grave goods.

5. Disposition of Native American Human Remains will be determined between the MLD and the PI, and, if:
 - a. The NAHC is unable to identify the MLD, OR the MLD failed to make a recommendation within 48 hours after being notified by the Commission, OR;
 - b. The landowner or authorized representative rejects the recommendation of the MLD and mediation in accordance with PRC 5097.94 (k) by the NAHC fails to provide measures acceptable to the landowner, THEN
 - c. To protect these sites, the landowner shall do one or more of the following:
 - (1) Record the site with the NAHC;
 - (2) Record an open space or conservation easement; or
 - (3) Record a document with the County.
 - d. Upon the discovery of multiple Native American human remains during a ground disturbing land development activity, the landowner may agree that additional conferral with descendants is necessary to consider culturally appropriate treatment of multiple Native American human remains. Culturally appropriate treatment of such a discovery may be ascertained from review of the site utilizing cultural and archaeological standards. Where the parties are unable to agree on the appropriate treatment measures the human remains and items associated and buried with Native American human remains shall be reinterred with appropriate dignity, pursuant to Section 5.c., above.

D. If Human Remains are **NOT** Native American

1. The PI shall contact the Medical Examiner and notify them of the historic era context of the burial.
2. The Medical Examiner will determine the appropriate course of action with the PI and City staff (PRC 5097.98).
3. If the remains are of historic origin, they shall be appropriately removed and conveyed to the San Diego Museum of Man for analysis. The decision for internment of the human remains shall be made in consultation with MMC, EAS, the applicant/landowner, any known descendant group, and the San Diego Museum of Man.

V. **Night and/or Weekend Work**

- A. If night and/or weekend work is included in the contract
 1. When night and/or weekend work is included in the contract package, the extent and timing shall be presented and discussed at the precon meeting.

2. The following procedures shall be followed.

a. No Discoveries

In the event that no discoveries were encountered during night and/or weekend work, the PI shall record the information on the CSV and submit to MMC via fax by 8AM of the next business day.

b. Discoveries

All discoveries shall be processed and documented using the existing procedures detailed in Sections III - During Construction, and IV - Discovery of Human Remains. Discovery of human remains shall always be treated as a significant discovery.

c. Potentially Significant Discoveries

If the PI determines that a potentially significant discovery has been made, the procedures detailed under Section III - During Construction and IV-Discovery of Human Remains shall be followed.

d. The PI shall immediately contact the RE and MMC, or by 8AM of the next business day to report and discuss the findings as indicated in Section III-B, unless other specific arrangements have been made.

B. If night and/or weekend work becomes necessary during the course of construction

1. The Construction Manager shall notify the RE, or BI, as appropriate, a minimum of 24 hours before the work is to begin.

2. The RE, or BI, as appropriate, shall notify MMC immediately.

C. All other procedures described above shall apply, as appropriate.

VI. Post Construction

A. Submittal of Draft Monitoring Report

1. The PI shall submit two copies of the Draft Monitoring Report (even if negative), prepared in accordance with the Historical Resources Guidelines (Appendix C/D) which describes the results, analysis, and conclusions of all phases of the Archaeological Monitoring Program (with appropriate graphics) to MMC via the RE for review and approval within 90 days following the completion of monitoring. **It should be noted that if the PI is unable to submit the Draft Monitoring Report within the allotted 90-day timeframe as a result of delays with analysis, special study results or other complex issues, a schedule shall be submitted to MMC establishing agreed due dates and the provision for submittal of monthly status reports until this measure can be met.**

- a. For significant archaeological resources encountered during monitoring, the Archaeological Data Recovery Program or Pipeline Trenching Discovery Process shall be included in the Draft Monitoring Report.
 - b. Recording Sites with State of California Department of Parks and Recreation
The PI shall be responsible for recording (on the appropriate State of California Department of Park and Recreation forms-DPR 523 A/B) any significant or potentially significant resources encountered during the Archaeological Monitoring Program in accordance with the City's Historical Resources Guidelines, and submittal of such forms to the South Coastal Information Center with the Final Monitoring Report.
2. MMC shall return the Draft Monitoring Report to the PI via the RE for revision or, for preparation of the Final Report.
 3. The PI shall submit revised Draft Monitoring Report to MMC via the RE for approval.
 4. MMC shall provide written verification to the PI of the approved report.
 5. MMC shall notify the RE or BI, as appropriate, of receipt of all Draft Monitoring Report submittals and approvals.
- B. Handling of Artifacts
1. The PI shall be responsible for ensuring that all cultural remains collected are cleaned and catalogued.
 2. The PI shall be responsible for ensuring that all artifacts are analyzed to identify function and chronology as they relate to the history of the area; that faunal material is identified as to species; and that specialty studies are completed, as appropriate.
- C. Curation of artifacts: Accession Agreement and Acceptance Verification
1. The PI shall be responsible for ensuring that all artifacts associated with the survey, testing and/or data recovery for this project are permanently curated with an appropriate institution. This shall be completed in consultation with MMC and the Native American representative, as applicable.
 2. When applicable to the situation, the PI shall include written verification from the Native American consultant/monitor indicating that Native American resources were treated in accordance with state law and/or applicable agreements. If the resources were reinterred, verification shall be provided to show what protective measures were taken to ensure no further disturbance occurs in accordance with Section IV – Discovery of Human Remains, Subsection C.
 3. The PI shall submit the Accession Agreement and catalogue record(s) to the RE or BI, as appropriate for donor signature with a copy submitted to MMC.
 4. The RE or BI, as appropriate shall obtain signature on the Accession Agreement and shall return to PI with copy submitted to MMC.

5. The PI shall include the Acceptance Verification from the curation institution in the Final Monitoring Report submitted to the RE or BI and MMC.
- D. Final Monitoring Report(s)
1. The PI shall submit one copy of the approved Final Monitoring Report to the RE or BI as appropriate, and one copy to MMC (even if negative), within 90 days after notification from MMC of the approved report.
 2. The RE shall, in no case, issue the Notice of Completion until receiving a copy of the approved Final Monitoring Report from MMC which includes the Acceptance Verification from the curation institution.

PALEONTOLOGICAL RESOURCES

I. Prior to Permit Issuance or Bid Opening/Bid Award

- A. Entitlements Plan Check
1. Prior to permit issuance or Bid Opening/Bid Award, whichever is applicable, the Assistant Deputy Director (ADD) Environmental designee shall verify that the requirements for Paleontological Monitoring have been noted on the appropriate construction documents.
- B. Letters of Qualification have been submitted to ADD
1. Prior to Bid Award, the applicant shall submit a letter of verification to Mitigation Monitoring Coordination (MMC) identifying the Principal Investigator (PI) for the project and the names of all persons involved in the paleontological monitoring program, as defined in the City of San Diego Paleontology Guidelines.
 2. MMC will provide a letter to the applicant confirming the qualifications of the PI and all persons involved in the paleontological monitoring of the project.
 3. Prior to the start of work, the applicant shall obtain approval from MMC for any personnel changes associated with the monitoring program.

II. Prior to Start of Construction

- A. Verification of Records Search
1. The PI shall provide verification to MMC that a site specific records search has been completed. Verification includes, but is not limited to a copy of a confirmation letter from San Diego Natural History Museum, other institution or, if the search was in-house, a letter of verification from the PI stating that the search was completed.
 2. The letter shall introduce any pertinent information concerning expectations and probabilities of discovery during trenching and/or grading activities.
- B. PI Shall Attend Precon Meetings
1. Prior to beginning any work that requires monitoring, the Applicant shall arrange a Precon Meeting that shall include the PI, Construction Manager (CM) and/or Grading Contractor, Resident Engineer (RE), Building Inspector (BI), if appropriate, and MMC. The qualified paleontologist shall attend any grading/excavation related Precon Meetings to make comments and/or suggestions concerning the Paleontological Monitoring program with the Construction Manager and/or Grading Contractor.
 - a. If the PI is unable to attend the Precon Meeting, the Applicant shall schedule a focused Precon Meeting with MMC, the PI, RE, CM or BI, if appropriate, prior to the start of any work that requires monitoring.

2. Acknowledgement of Responsibility for Curation (CIP or Other Public Projects)
The applicant shall submit a letter to MMC acknowledging their responsibility for the cost of curation associated with all phases of the paleontological monitoring program.
3. Identify Areas to be Monitored
 - a. Prior to the start of any work that requires monitoring, the PI shall submit a Paleontological Monitoring Exhibit (PME) based on the appropriate construction documents (reduced to 11x17) to MMC for approval identifying the areas to be monitored including the delineation of grading/excavation limits. Monitoring shall begin at depths below 10 feet from existing grade or as determined by the PI in consultation with MMC. The determination shall be based on site specific records search data which supports monitoring at depths less than ten feet.
 - b. The PME shall be based on the results of a site specific records search as well as information regarding existing known soil conditions (native or formation).
 - c. MMC shall notify the PI that the PME has been approved.
4. When Monitoring Will Occur
 - a. Prior to the start of any work, the PI shall also submit a construction schedule to MMC through the RE indicating when and where monitoring will occur.
 - b. The PI may submit a detailed letter to MMC prior to the start of work or during construction requesting a modification to the monitoring program. This request shall be based on relevant information such as review of final construction documents which indicate conditions such as depth of excavation and/or site graded to bedrock, presence or absence of fossil resources, etc., which may reduce or increase the potential for resources to be present.
5. Approval of PME and Construction Schedule
After approval of the PME by MMC, the PI shall submit to MMC written authorization of the PME and Construction Schedule from the CM.

III. During Construction

- A. Monitor Shall be Present During Grading/Excavation/Trenching
 1. The monitor shall be present full-time during grading/excavation/trenching activities including, but not limited to mainline, laterals, jacking and receiving pits, services and all other appurtenances associated with underground utilities as identified on the PME that could result in impacts to formations with high and/or moderate resource sensitivity. **The Construction Manager is responsible for notifying the RE, PI, and MMC of changes to any construction activities such as in the case of a potential safety concern within the area being monitored. In certain circumstances OSHA safety requirements may necessitate modification of the PME.**
 2. The PI may submit a detailed letter to MMC during construction requesting a modification to the monitoring program when a field condition such as trenching activities that do not encounter formational soils as previously assumed, and/or when unique/unusual fossils are encountered, which may reduce or increase the potential for resources to be present.
 3. The monitor shall document field activity via the Consultant Site Visit Record (CSV). The CSV's shall be faxed by the CM to the RE the first day of monitoring, the last day of monitoring, monthly (**Notification of Monitoring Completion**), and in the case of ANY discoveries. The RE shall forward copies to MMC.
- B. Discovery Notification Process

1. In the event of a discovery, the Paleontological Monitor shall direct the contractor to temporarily divert trenching activities in the area of discovery and immediately notify the RE or BI, as appropriate.
 2. The Monitor shall immediately notify the PI (unless Monitor is the PI) of the discovery.
 3. The PI shall immediately notify MMC by phone of the discovery, and shall also submit written documentation to MMC within 24 hours by fax or email with photos of the resource in context, if possible.
- C. Determination of Significance
1. The PI shall evaluate the significance of the resource.
 - a. The PI shall immediately notify MMC by phone to discuss significance determination and shall also submit a letter to MMC indicating whether additional mitigation is required. The determination of significance for fossil discoveries shall be at the discretion of the PI.
 - b. If the resource is significant, the PI shall submit a Paleontological Recovery Program (PRP) and obtain written approval of the program from MMC, MC and/or RE. PRP and any mitigation must be approved by MMC, RE and/or CM before ground disturbing activities in the area of discovery will be allowed to resume.
 - (1). Note: For pipeline trenching projects only, the PI shall implement the Discovery Process for Pipeline Trenching projects identified below under "D."
 - c. If resource is not significant (e.g., small pieces of broken common shell fragments or other scattered common fossils) the PI shall notify the RE, or BI as appropriate, that a non-significant discovery has been made. The Paleontologist shall continue to monitor the area without notification to MMC unless a significant resource is encountered.
 - d. The PI shall submit a letter to MMC indicating that fossil resources will be collected, curated, and documented in the Final Monitoring Report. The letter shall also indicate that no further work is required.
 - (1). Note: For Pipeline Trenching Projects Only. If the fossil discovery is limited in size, both in length and depth; the information value is limited and there are no unique fossil features associated with the discovery area, then the discovery should be considered not significant.
 - (2). Note, for Pipeline Trenching Projects Only: If significance cannot be determined, the Final Monitoring Report and Site Record shall identify the discovery as Potentially Significant.
- D. Discovery Process for Significant Resources - Pipeline Trenching Projects
- The following procedure constitutes adequate mitigation of a significant discovery encountered during pipeline trenching activities including but not limited to excavation for jacking pits, receiving pits, laterals, and manholes to reduce impacts to below a level of significance.
1. Procedures for documentation, curation and reporting
 - a. One hundred percent of the fossil resources within the trench alignment and width shall be documented in-situ photographically, drawn in plan view (trench and profiles of side walls), recovered from the trench and photographed after cleaning, then analyzed and curated consistent with Society of Invertebrate Paleontology Standards. The remainder of the deposit within the limits of excavation (trench walls) shall be left intact and so documented.

- b. The PI shall prepare a Draft Monitoring Report and submit to MMC via the RE as indicated in Section VI-A.
- c. The PI shall be responsible for recording (on the appropriate forms for the San Diego Natural History Museum) the resource(s) encountered during the Paleontological Monitoring Program in accordance with the City's Paleontological Guidelines. The forms shall be submitted to the San Diego Natural History Museum and included in the Final Monitoring Report.
- d. The Final Monitoring Report shall include a recommendation for monitoring of any future work in the vicinity of the resource.

IV. Night and/or Weekend Work

- A. If night and/or weekend work is included in the contract
 - 1. When night and/or weekend work is included in the contract package, the extent and timing shall be presented and discussed at the precon meeting.
 - 2. The following procedures shall be followed.
 - a. No Discoveries
In the event that no discoveries were encountered during night and/or weekend work, The PI shall record the information on the CSVR and submit to MMC via the RE via fax by 8AM on the next business day.
 - b. Discoveries
All discoveries shall be processed and documented using the existing procedures detailed in Sections III - During Construction.
 - c. Potentially Significant Discoveries
If the PI determines that a potentially significant discovery has been made, the procedures detailed under Section III - During Construction shall be followed.
 - d. The PI shall immediately contact the RE and MMC, or by 8AM on the next business day to report and discuss the findings as indicated in Section III-B, unless other specific arrangements have been made.
- B. If night and/or weekend work becomes necessary during the course of construction
 - 1. The Construction Manager shall notify the RE, or BI, as appropriate, a minimum of 24 hours before the work is to begin.
 - 2. The RE, or BI, as appropriate, shall notify MMC immediately.
- C. All other procedures described above shall apply, as appropriate.

V. Post Construction

- A. Preparation and Submittal of Draft Monitoring Report
 - 1. The PI shall submit two copies of the Draft Monitoring Report (even if negative), prepared in accordance with the Paleontological Guidelines which describes the results, analysis, and conclusions of all phases of the Paleontological Monitoring Program (with appropriate graphics) to MMC via the RE for review and approval within 90 days following the completion of monitoring,
 - a. For significant paleontological resources encountered during monitoring, the Paleontological Recovery Program or Pipeline Trenching Discovery Process shall be included in the Draft Monitoring Report.
 - b. Recording Sites with the San Diego Natural History Museum
The PI shall be responsible for recording (on the appropriate forms) any significant or potentially significant fossil resources encountered during the Paleontological Monitoring Program in accordance with the City's Paleontological Guidelines, and submittal of such forms to the San Diego Natural History Museum with the Final Monitoring Report.

2. MMC shall return the Draft Monitoring Report to the PI via the RE for revision or, for preparation of the Final Report.
 3. The PI shall submit revised Draft Monitoring Report to MMC via the RE for approval.
 4. MMC shall provide written verification to the PI of the approved report.
 5. MMC shall notify the RE or BI, as appropriate, of receipt of all Draft Monitoring Report submittals and approvals.
- B. Handling of Fossil Remains
1. The PI shall be responsible for ensuring that all fossil remains collected are cleaned and catalogued.
- C. Curation of artifacts: Deed of Gift and Acceptance Verification
1. The PI shall be responsible for ensuring that all fossil remains associated with the monitoring for this project are permanently curated with an appropriate institution.
 2. The PI shall submit the Deed of Gift and catalogue record(s) to the RE or BI, as appropriate for donor signature with a copy submitted to MMC.
 3. The RE or BI, as appropriate shall obtain signature on the Deed of Gift and shall return to PI with copy submitted to MMC.
 4. The PI shall include the Acceptance Verification from the curation institution in the Final Monitoring Report submitted to the RE or BI and MMC.
- D. Final Monitoring Report(s)
1. The PI shall submit two copies of the Final Monitoring Report to MMC (even if negative), within 90 days after notification from MMC of the approved report.
 2. The RE shall, in no case, issue the Notice of Completion until receiving a copy of the approved Final Monitoring Report from MMC which includes the Acceptance Verification from the curation institution.

The above Mitigation Monitoring and Reporting Program will require additional fees and/or deposits to be collected prior to the issuance of building permits, certificates or occupancy and/or final maps to ensure the successful completion of the monitoring program.

VII. IMPACT SIGNIFICANCE

This Addendum also identifies that all significant project impacts would be mitigated to below a level of significance, consistent with the previously certified MND.

VIII. CERTIFICATION

Copies of the addendum, the final MND, **the Mitigation Monitoring and Reporting Program** and associated project-specific technical appendices, if any, may be reviewed in the office of the Development Services Department, or purchased for the cost of reproduction.

 Mark Brunette, Senior Planner
 Development Services Department

10/11/16
 Date of Final Report

Analyst: Chris Tracy, AICP, Associate Planner

Attachments:

Figure 1: Location Map
 Mitigated Negative Declaration No. 255100/SCH No. 2011091045

The Addendum to Mitigated Negative Declaration No. 255100 was not circulated for public review pursuant to San Diego Municipal Code (SDMC) Chapter 6, Article 9, Paragraph 69.0211 (Addenda to Environmental Reports). The final Addendum was distributed to the following City of San Diego staff members for informational purposes in accordance with CEQA Section 15164.

DISTRIBUTION:

City of San Diego

Development Services

Peter Kann, Development Project Manager

Chris Tracy, Environmental Analyst

Sam Johnson, MMC

Public Works

Carrie Purcell, Assistant Deputy Director

Roberto Vejar-Parra, Project Manager

Nabil Batta, Senior Civil Engineer

Jing Debeliso, Assistant Engineer

Jerry Jukubauskas, Senior Planner

Megan Hickey, Junior Planner

The City of
SAN DIEGO Public Works
SEWER AND AC WATER GROUP 764

SENIOR ENGINEER
 NABIL BAPTA
 (619) 533-4145



PROJECT MANAGER
 ROBERTO VEJAR-PARRA
 (619) 533-5402

PROJECT ENGINEER
 JING DEBELISO
 (619) 533-5285

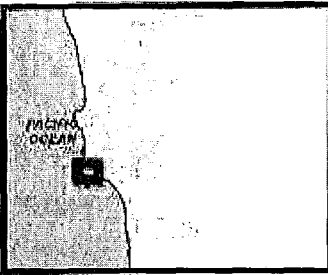
FOR QUESTIONS ABOUT THIS PROJECT
 Call: (619) 533-4207
 Email: engineering@sandiego.gov



Legend

-  Prop Sewer
-  Prop Water
-  Rehab Ex VC Swr

LOCATION MAP 1-2



COMMUNITY NAME: PENINSULA AREA

COUNCIL DISTRICT: 2

SAP ID: B00368 (S) \

SHEET 1 OF 2 Date: AUGUST 23, 2016
 Sewer & AC Water GJ 764 & 821



B15106 (W)
 75 | Page

Appendix A - Addendum To A Mitigated Negative Declaration (AMND) and Notice of Determination (NOD)

THIS MAP/DRAWING IS PROVIDED WITHOUT WARRANTY OF ANY KIND, EITHER EXPRESS OR IMPLIED, INCLUDING, BUT NOT LIMITED TO, THE IMPLIED WARRANTIES OR MERCHANTABILITY AND FITNESS FOR A PARTICULAR PURPOSE. NOTE: THIS PRODUCT MAY CONTAIN INFORMATION FROM THE SANDAG Regional Information System which cannot be reproduced without the written permission of SANDAG. This product may contain geospatial information with permission granted by RANDI MCDEVALLY, a CDMP/PAIS to SanGIS. This map is copyrighted by RANDI MCDEVALLY, 1172 CROWDSTOWN BLVD, SAN DIEGO, CA 92108. All other data used, including the proposed sewer, water, and rehab lines, are the property of the City of San Diego.

The City of **SAN DIEGO** Public Works

SEWER AND AC WATER GROUP 764

SENIOR ENGINEER
NABIL BATTA
(619) 533-4145



PROJECT MANAGER
ROBERTO VEJAR-PARRA
(619) 533-5402

PROJECT ENGINEER
JING DEBELISO
(619) 533-5285

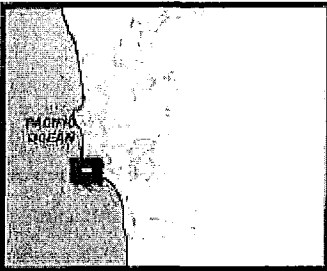
FOR QUESTIONS ABOUT THIS PROJECT
Call: (619) 533-4207
Email: engineering@sandiego.gov



Legend

-  Prop Sewer
-  Prop Water
-  Rehab Ex VC Swr

LOCATION MAP 2-2



THIS MAP/DRAWING IS PROVIDED WITHOUT WARRANTY OF ANY KIND, EITHER EXPRESS OR IMPLIED, INCLUDING, BUT NOT LIMITED TO, THE IMPLIED WARRANTIES OF MERCHANTABILITY AND FITNESS FOR A PARTICULAR PURPOSE. NOTE: THIS PRODUCT MAY CONTAIN INFORMATION REPRODUCED WITH PERMISSION FROM THE SAN DIEGO REGIONAL INFORMATION SYSTEM WHICH CANNOT BE REPRODUCED WITHOUT THE WRITTEN PERMISSION OF SANDAG. THIS PRODUCT MAY CONTAIN INFORMATION REPRODUCED WITH PERMISSION FROM SAND MCNALLY & COMPANY'S SERVICES. THIS MAP IS COPYRIGHTED BY SANDAG. SANDAG IS NOT RESPONSIBLE FOR ANY ERRORS OR OMISSIONS. IT IS THE USER'S RESPONSIBILITY TO VERIFY THE ACCURACY OF THE INFORMATION SHOWN ON THIS MAP/DRAWING. SANDAG AND SANDAG CONSULTANTS SHALL NOT BE HELD LIABLE FOR ANY DAMAGES, INCLUDING REASONABLE ATTORNEY'S FEES, ARISING FROM THE USE OF THIS MAP/DRAWING.

The City of **SAN DIEGO** Public Works

AC WATER & SEWER GROUP 821

SENIOR ENGINEER
NABIL BATTA
(619) 533-4145



PROJECT MANAGER
ROBERTO VEJAR-PARRA
(619) 533-5402

PROJECT ENGINEER
JING DEMELISO
(619) 533-5285

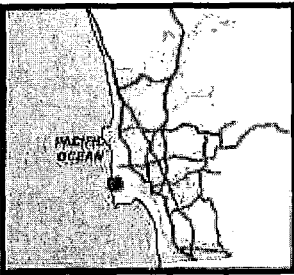
FOR QUESTIONS ABOUT THIS PROJECT
Call: (619) 533-4207
Email: engineering@sanidiego.gov



Legend

-  PROPOSED SEWER MAIN
-  PROPOSED WATER MAIN
-  REHAB 8 INCH VC SEWER MAIN

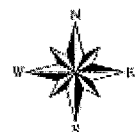

COMMUNITY NAME: Peninsula

COUNCIL DISTRICT: 2

SAP ID: B00413 (S) \

Date: AUGUST 23, 2016

Sewer & AC Water GJ 764 & 821



B15107 (W)

77 | Page

Appendix A - Addendum To A Mitigated Negative Declaration (AMND) and Notice of Determination (NOD)

THIS MAP/DATA IS PROVIDED WITHOUT WARRANTY OF ANY KIND, EITHER EXPRESS OR IMPLIED, INCLUDING, BUT NOT LIMITED TO, THE IMPLIED WARRANTIES OR MERCHANTABILITY AND FITNESS FOR A PARTICULAR PURPOSE. NEAR: This product may contain information reproduced with permission granted by RAND McNALLY & COMPANY, INC. to SanGIS. This map is copyrighted and cannot be reproduced without the written permission of RAND McNALLY & COMPANY, INC. In the event of a conflict between the information on this map and the information on the ground, the information on the ground shall prevail. RAND McNALLY & COMPANY, INC. is not responsible for any errors or omissions on this map.



MITIGATED NEGATIVE DECLARATION

Project No. 255100
SCH No. 2011091045

SUBJECT: Citywide Pipeline Projects: COUNCIL APPROVAL to allow for the replacement, rehabilitation, relocation, point repair, new trenching, trenchless construction, and abandonment of water and/or sewer pipeline alignments and associated improvements such as curb ramps, sewer lateral connections, water service connections, manholes, new pavement/slurry, the removal and/or replacement of street trees and the removal and/or replacement of street lights. This environmental document covers the analysis for ~~five~~ four (4) near-term pipeline projects (Harbor Drive Pipeline, Water Group 949, ~~Sewer Group 787~~, Water Group 914, and Sewer/Water Group 732), as well as any subsequent future pipeline projects. The construction footprint for a typical pipeline project, including staging areas and other areas (such as access) would be located within the City of San Diego Public Right-of-Way (PROW) and/or within public easements and may include planned pipeline construction within private easements from the PROW to the service connection. A signed agreement between the City and the property owner would be required for work conducted on private property. Project types that would be included in the analysis contained herein would consist of sewer and water group jobs, trunk sewers, large diameter water pipeline projects, new and/or replacement manholes, new/or replacement fire hydrants, and other necessary appurtenances. All associated equipment would be staged within the existing PROW adjacent to the work areas. The near-term and future projects covered in the document would not impact *Sensitive Biological Resources* or *Environmentally Sensitive Lands (ESL)* as defined in the Land Development Code and would not encroach into the City's Multi-Habitat Planning Area (MHPA). Applicant: The City of San Diego Engineering and Capital Projects Department AND Public Utilities Department.

Update 10/20/2011

Revisions to this document have been made when compared to the Draft Mitigated Negative Declaration (DMND) dated September 9, 2011. In response to the Comment Letter received from The California Department of Fish and Game, further description and graphics of Water Group 949 as it relates to the MHPA has been added to the Final MND. Please note that Sewer Group 787, which is adjacent to the MHPA, has been removed from the project description and is no longer covered in this MND.

The modifications to the FMND are denoted by strikeout and underline format. In accordance with the California Environmental Quality Act, Section 15073.5 (c)(4), the addition of new information that clarifies, amplifies, or makes insignificant modification does not require recirculation as there are no new impacts and no new mitigation identified. An environmental document need only be recirculated when there is identification of new significant environmental impact or the addition of a new mitigation measure required to avoid a significant environmental impact. The addition

of corrected mitigation language within the environmental document does not affect the environmental analysis or conclusions of the MND.

Construction for the near-term and any future projects is anticipated to occur during the daytime hours Monday through Friday, but may occur during the weekend, if necessary. The contractor would comply with all applicable requirements described in the latest edition of the *Standard Specifications for Public Works Construction ("GREENBOOK")* and the latest edition of the *City of San Diego Standard Specifications for Public Works Construction ("WHITEBOOK")*. The City's supplement addresses unique circumstances to the City of San Diego that are not addressed in the GREENBOOK and would therefore take precedence in the event of a conflict. The contractor would also comply with the California Department of Transportation *Manual of Traffic Controls for Construction and Maintenance Work Zones*. If the Average Daily Traffic (ADT) within a given project(s) vicinity is 10,000 ADT or greater, a traffic control plan would be prepared and implemented in accordance with the *City of San Diego Standard Drawings Manual of Traffic Control for Construction and Maintenance Work Zones*. For proposals subject to 10,000 ADT or less, traffic control may be managed through shop drawings during construction. Construction methods to be employed would consist of, but not be limited to:

Open Trenching: The open trench method of construction would be used for complete replacement and new alignment portions of the project. Trenches are typically four feet wide and are dug with excavations and similar large construction equipment.

Rehabilitation: Rehabilitation of alignment involves installing a new lining in old pipelines. The insertion is done through existing manhole access points and does not require removal of pavement or excavation of soils.

Abandonment: Pipeline abandonment activities would be similar to rehabilitation methods in that no surface/subsurface disturbance would occur. This process may involve slurry or grout material injected into the abandoned lines via manhole access. The top portion of the manhole is then typically removed and the remaining space backfilled and paved over.

Potholing: Potholing would be used to verify reconnection of laterals to main where lines would be raised or realigned (higher than existing depth, but still below ground) or to verify utility crossings. These "potholes" are made by using vacuum type equipment to open up small holes into the street of pavement.

Point Repairs: Point repairs include replacing a portion of a pipe segment by open trench excavation methods in which localized structural defects have been identified. Generally, point repairs are confined to an eight-foot section of pipe.

The following near term project(s) have been reviewed by the City of San Diego, Development Services Department (DSD) for compliance with the Land Development Code and have been determined to be exempt from a Site Development Permit (SDP) and/or a Coastal Development Permit (CDP). These projects would involve excavation in areas having a high resource sensitivity and potential for encountering archaeological and paleontological resources during construction related activities. Therefore, mitigation would be required to reduce potential significant impacts to archaeological and paleontological resources to below a level of significance. With respect to Storm Water, all projects would be reviewed for compliance with the City's Storm Water Standards

Manual. All projects that are not-exempt from the Standard Urban Storm Water Mitigation Plan (SUSMP) would incorporate appropriate Permanent Best Management Practices (BMPs) and construction BMPs into the project design(s) and during construction, as required. As such, all projects would comply with the requirement of the Municipal Storm Water Permit.

HARBOR DRIVE PIPELINE (PROJECT NO. 206100)

The Harbor Drive Pipeline includes the replacement of 4.4 miles of 16-inch cast iron (CI) and asbestos cement (AC) pipe that comprises the Harbor Drive 1st and 2nd Pipelines (HD-1 and HD-2) at a depth no greater than five (5) feet. Facility age and cast iron main replacement are the primary drivers for these projects, but due to the history of AC breaks in the area, approximately 1.0 mile of AC replacement is also included. The project is anticipated to be awarded in Fiscal Year 2013.

HD-1 and HD-2 were built primarily in the 1940's and 1950's and were made out of cast iron or asbestos cement and serve the western most part of the University Heights 390 Zone and the northern section of the Point Loma East 260 Zone. The pipelines also serve as redundancy to each other. Several segments were replaced by various City of San Diego Public Utilities Department projects throughout the years and those segments are not a part of the current scope. Previously replaced segments were 16 inch PVC, except for the bridge crossing which used 24-inch CMLC. The pipeline is located entirely within the PROW, will not require any easements, and is not adjacent to the MHPA or located within any designated historical districts. The following streets would be affected by this project: West Laurel, Pacific Highway, North Harbor Drive (within the roadway, under the bridge and within landscape areas), Nimitz Boulevard, Rosecrans Street, Evergreen Street, Hugo Street, Locust Street, Canon Street, Avenida De Portugal, and Point Loma Avenue.

Mitigation for the Harbor Drive Pipeline: Historical Resources (Archaeological Monitoring)

WATER GROUP 949 (PROJECT NO. 232719)

Water Group 949 would consist of the replacement and installation of 5.27 miles of water mains within the Skyline- Paradise Hills, University, Clairemont Mesa, Southeastern San Diego (Greater Golden Hills) community planning areas. 16,931 Linear Feet (LF) of 16-inch cast iron water mains would be replace-in-place with new 16-inch polyvinyl chloride (PVC) pipe within the existing trench. The remaining 10,913 LF of new 16-inch PVC would be installed in new trenches. All work within Regents Road, Site 2 (Figure 8), adjacent to the MHPA would only occur within the developed footprint such as the paved right of way, and concrete sidewalk or slab areas. In addition, all work within 100 feet of the MHPA would observe mitigation such as but not limited to, bird breeding season measures, avoidance of discharge into the MHPA, and avoidance of direct lighting towards the MHPA areas. As such, no impacts to MHPA and/or sensitive resources would occur. The project would also include replacement and reinstallation of valves, water services, fire hydrants, and other appurtenances and would also included the construction of curb ramps, and street resurfacing. Traffic control measures and Best Management Practices (BMPs) would be implemented during construction. Any street tree removal, relocation, and/or trimming would be done under the supervision of the City Arborist. All staging of construction equipment will be located outside of any potentially sensitive areas. The following streets and nearby alleyways would be affected by this project: Tuther Way, Cielo Drive, Woodman Street, Skyline Drive, Regents Road, Hidalgo Avenue, Clairemont Mesa Boulevard, Luna Avenue, B Street, F Street, Ash Street, 25th Street, and 27th Street.

Mitigation Required for Water Group 949: This project would require the implementation of MHPA Land Use Adjacency Guidelines in the University and Clairemont Mesa Community Planning areas that are adjacent (within 100 feet) to the MHPA and Historical Resources (Built Environment) mitigation for the area of the project located within the Greater Golden Hill Historic District.

SEWER GROUP 787 (PROJECT NO. 231928)

Sewer Group 787 would consist of the replacement of 26,436 lineal feet (LF) of existing 16-inch cast iron sewer pipe with new 16-inch polyvinyl chloride (PVC) pipe within the existing trench. A total of 1,267 LF of new 16-inch PVC sewer alignment would be installed in new trenches. In addition, the project would abandon 1,606 LF of existing 16-inch cast iron pipe. The proposed project would be installed by conventional excavation (open trench) in trenches from 3-5 feet deep. The project would affect the following streets and nearby alleyways: 42nd Street, Monroe Avenue, Edgeware Road, Polk Avenue, Orange Avenue, Menlo Avenue, 47TH Street, Dwight Street, Myrtle Avenue, Manzanita Place, Heather Street, Dahlia Street, Poplar Street, Columbine Street, Pepper Drive, Juniper Street, Marigold Street, Sumac Drive, 44TH Street, Laurie Lane, and Roseview Place all within the City Heights and Kensington-Talmadge Community Planning Areas.

Mitigation Required for Water Group 787: This project would require the implementation of MHPA Land Use Adjacency Guidelines in the City Heights and Kensington-Talmadge Community Planning areas that are adjacent (within 100 feet) to the MHPA, Historical Resources (Archaeological and Paleontological Monitoring).

WATER GROUP 914 (PROJECT NO. 233447)

Water Group 914 would consist of the replacement and installation of approximately 21,729 lineal feet (LF) of existing 6-inch, 8-inch and 12-inch cast iron pipes and 6-inch asphalt concrete pipes with new 8-inch, 12-inch and 16-inch polyvinyl chloride (PVC) pipe. Also included would be the construction of two underground pressure regulator stations that measure 54 square-feet and 6.5 feet deep each. 17,472 LF would be located in existing trenches and 4,257 LF would be located in new trench lines. The proposed project would be installed by conventional excavation (open trench) in trenches from 3-5 feet deep. However two 300 LF parallel line sections (600 LF total) of the water alignment would be installed by trenchless methodology utilizing two (2) 40 square foot launch and receiver pits. The trenchless installation would occur at the intersection of Coronado Avenue and Ebers Street and is designed to avoid a recorded archaeological resource at this intersection. The trenchless methodology would employ directional underground boring that would install the pipe at a depth deeper than the recorded resource. In addition, a 4-inch AC water segment of approximately 520 LF located along Point Loma Avenue between Guizot Street and Santa Barbara Street will be abandoned in place. The project would affect the following streets and nearby alleyways: Point Loma Avenue, Santa Barbara Street, Bermuda Avenue, Pescadero Avenue, Cable Street, Orchard Avenue, Froude Street, Sunset Cliffs Boulevard, Savoy Circle, and Del Monte Avenue all within the Ocean Beach and Peninsula Community Planning Areas.

Mitigation for Water Group 914: Historical Resources (Archaeological Monitoring) and (Built Environment)

SEWER AND WATER GROUP 732 (PROJECT NO. 206610)

Sewer and Water Group Job 732 would consist of the installation of approximately 5,500 total linear feet (LF) of 8 inch Polyvinyl Chloride (PVC) sewer pipe, and approximately 3,000 total linear feet (LF) of 12 inch PVC water pipe. Approximately, 1,035 LF of water pipe would be rehabilitated using trenchless technology in the same trench, with the remainder of the installation accomplished through open trenching. Related work would include construction of new manholes, replacement and re-plumbing of sewer laterals, installation of curb ramps, pavement restoration, traffic control, and storm water best management practices. Construction of the project would affect portions of the following streets and adjacent alleys in the Peninsula Community Plan area: Xenophon Street, Yonge Street, Zola Street, Alcott Street, Browning Street, Plum Street, Willow Street, Evergreen Street, Locust Street, and Rosecrans Street.

Mitigation Required for Sewer and Water Group 732: Historical Resources (Archaeological and Paleontological Monitoring).SUBSEQUENT PIPELINE PROJECT REVIEW (LONG TERM)

Applications for the replacement, rehabilitation, relocation, point repair, open trenching and abandonment of water and/or sewer pipeline alignments within the City of San Diego PROW as indicated in the Subject block above and in the Project Description discussion of the Initial Study would be analyzed for potential environmental impacts to Historical Resources (Archaeology, Paleontology and the Built Environment) and Land Use (MSCP/MHPA), and reviewed for consistency with this Mitigated Negative Declaration (MND). Where it can be determined that the project is "consistent" with this MND and no additional potential significant impacts would occur pursuant to State CEQA Guideline § 15162 (i.e. the involvement of new significant environmental effects of a substantial increase in the severity of previously identified effects) or if the project would result in minor technical changes or additions, then an Addendum to this MND would be prepared pursuant to § 15164. Where future projects are found not to be consistent with this MND, then a new Initial Study and project specific MND shall be prepared.

- I. PROJECT DESCRIPTION: See attached Initial Study.
- II. ENVIRONMENTAL SETTING: See attached Initial Study.
- III. DETERMINATION:

The City of San Diego conducted an Initial Study which determined that the near term projects and any future subsequent projects could have a significant environmental effect in the following areas(s): Land Use (MSCP/MHPA Land Use Adjacency), Historical Resources (Built Environment), Historical Resources (Archaeology) and Paleontology. When subsequent projects are submitted to DSD, the Environmental Analysis Section (EAS) will determine which of the project specific mitigation measures listed in Section V. would apply. Subsequent revisions in the project proposal create the specific mitigation identified in Section V of this Mitigated Negative Declaration. Projects as revised now avoid or mitigate the potentially significant environmental effects previously identified, and the preparation of an Environmental Impact Report will not be required.

IV. DOCUMENTATION:

The attached Initial Study documents the reasons to support the above Determination.

V. MITIGATION, MONITORING AND REPORTING PROGRAM (MMRP):

A. GENERAL REQUIREMENTS – PART I

Plan Check Phase (prior to permit issuance)

1. Prior to Bid Opening/Bid Award or beginning any construction related activity on-site, the Development Services Department (DSD) Director's Environmental Designee (ED) shall review and approve all Construction Documents (CD) (plans, specification, details, etc.) to ensure the MMRP requirements have been incorporated.
2. In addition, the ED shall verify that the MMRP Conditions/Notes that apply ONLY to the construction phases of this project are included VERBATIM, under the heading, "ENVIRONMENTAL/MITIGATION REQUIREMENTS."
3. These notes must be shown within the first three (3) sheets of the construction documents in the format specified for engineering construction document templates as shown on the City website:

<http://www.sandiego.gov/development-services/industry/standtemp.shtml>

4. The **TITLE INDEX SHEET** must also show on which pages the "Environmental/Mitigation Requirements" notes are provided.

B. GENERAL REQUIREMENTS – PART II

Post Plan Check (After permit issuance/Prior to start of construction)

1. **PRE CONSTRUCTION MEETING IS REQUIRED TEN (10) WORKING DAYS PRIOR TO BEGINNING ANY WORK ON THIS PROJECT.** The PERMIT HOLDER/OWNER is responsible to arrange and perform this meeting by contacting the CITY RESIDENT ENGINEER (RE) of the Field Engineering Division and City staff from MITIGATION MONITORING COORDINATION (MMC). Attendees must also include the Permit holder's Representative(s), Job Site Superintendent and the following consultants as necessary:

Biologist, Archaeologist, Native American Monitor, Historian and Paleontologist

Note: Failure of all responsible Permit Holder's representatives and consultants to attend shall require an additional meeting with all parties present.

CONTACT INFORMATION:

- a) The PRIMARY POINT OF CONTACT is the RE at the **Field Engineering Division 858-627-3200**
- b) For Clarification of ENVIRONMENTAL REQUIREMENTS, it is also required to call **RE and MMC at 858-627-3360**

2. MMRP COMPLIANCE: This Project, Project Tracking System (PTS) No. 255100, or for subsequent future projects the associated PTS No, shall conform to the mitigation requirements contained in the associated Environmental Document and implemented to the satisfaction of the DSD’s ED, MMC and the City Engineer (RE). The requirements may not be reduced or changed but may be annotated (i.e. to explain when and how compliance is being met and location of verifying proof, etc.). Additional clarifying information may also be added to other relevant plan sheets and/or specifications as appropriate (i.e., specific locations, times of monitoring, methodology, etc

Note:

Permit Holder’s Representatives must alert RE and MMC if there are any discrepancies in the plans or notes, or any changes due to field conditions. All conflicts must be approved by RE and MMC BEFORE the work is performed.

3. OTHER AGENCY REQUIREMENTS: Evidence that any other agency requirements or permits have been obtained or are in process shall be submitted to the RE and MMC for review and acceptance prior to the beginning of work or within one week of the Permit Holder obtaining documentation of those permits or requirements. Evidence shall include copies of permits, letters of resolution or other documentation issued by the responsible agency as applicable.

4. MONITORING EXHIBITS: All consultants are required to submit, to RE and MMC, a monitoring exhibit on a 11x17 reduction of the appropriate construction plan, such as site plan, grading, landscape, etc., marked to clearly show the specific areas including the **LIMIT OF WORK**, scope of that discipline’s work, and notes indicating when in the construction schedule that work will be performed. When necessary for clarification, a detailed methodology of how the work will be performed shall be included.

5. OTHER SUBMITTALS AND INSPECTIONS: The Permit Holder/Owner’s representative shall submit all required documentation, verification letters, and requests for all associated inspections to the RE and MMC for approval per the following schedule:

Document Submittal/Inspection Checklist

<i>Issue Area</i>	<i>Document submittal</i>	<i>Associated Inspection/Approvals/Note</i>
General	Consultant Qualification Letters	Prior to Pre-construction Mtg.
General	Consultant Const. Monitoring	Prior to or at Pre-Construction Mtg.
Biology	Biology Reports	Limit of Work Verification
Historical	Historical Reports	Historical observation (built envirnmt)
Archaeology	Archaeology Reports	Archaeology observation
Paleontology	Paleontology Reports	Paleontology observation
Final MMRP		Final MMRP Inspection

SPECIFIC MMRP ISSUE AREA CONDITIONS/REQUIREMENTS:

A. LAND USE [MULTIPLE SPECIES CONSERVATION PROGRAM (MSCP) For PROJECTS WITHIN 100 FEET OF THE MHPA]

I. Prior to Permit Issuance

A. Prior to issuance of any construction permit, the DSD Environmental Designee (ED) shall verify the Applicant has accurately represented the project's design in the Construction Documents (CDs) that are in conformance with the associated discretionary permit conditions and Exhibit "A", and also the City's Multi-Species Conservation Program (MSCP) Land Use Adjacency Guidelines for the Multiple Habitat Planning Area (MHPA), including identifying adjacency as the potential for direct/indirect impacts where applicable. In addition, all CDs where applicable shall show the following:

- 1. Land Development / Grading / Boundaries** –MHPA boundaries on-site and adjacent properties shall be delineated on the CDs. The ED shall ensure that all grading is included within the development footprint, specifically manufactured slopes, disturbance, and development within or adjacent to the MHPA..
- 2. Drainage / Toxins** –All new and proposed parking lots and developed area in and adjacent to the MHPA shall be designed so they do not drain directly into the MHPA, All developed and paved areas must prevent the release of toxins, chemicals, petroleum products, exotic plant materials prior to release by incorporating the use of filtration devices, planted swales and/or planted detention/desiltation basins, or other approved permanent methods that are designed to minimize negative impacts, such as excessive water and toxins into the ecosystems of the MHPA.
- 3. Staging/storage, equipment maintenance, and trash** –All areas for staging, storage of equipment and materials, trash, equipment maintenance, and other construction related activities are within the development footprint. Provide a note on the plans that states: "*All construction related activity that may have potential for leakage or intrusion shall be monitored by the Qualified Biologist/Owners Representative to ensure there is no impact to the MHPA.*"
- 4. Barriers** –All new development within or adjacent to the MHPA shall provide fencing or other City approved barriers along the MHPA boundaries to direct public access to appropriate locations, to reduce domestic animal predation, and to direct wildlife to appropriate corridor crossing. Permanent barriers may include, but are not limited to, fencing (6-foot black vinyl coated chain link or equivalent), walls, rocks/boulders, vegetated buffers, and signage for access, litter, and educational purposes.
- 5. Lighting** – All building, site, and landscape lighting adjacent to the MHPA shall be directed away from the preserve using proper placement and adequate shielding to protect sensitive habitat. Where necessary, light from traffic or other incompatible uses, shall be shielded from the MHPA through the utilization of including, but not limited to, earth berms, fences, and/or plant material.
- 6. Invasive Plants** – Plant species within 100 feet of the MHPA shall comply with the Landscape Regulations (LDC142.0400 and per table 142-04F, Revegetation and Irrigation Requirements) and be non invasive. Landscape plans shall include a note that states: "*The ongoing maintenance requirements of the property owner shall*

prohibit the use of any planting that are invasive, per City Regulations, Standards, guidelines, etc., within 100 feet of the MHPA."

7. **Brush Management** –All new development adjacent to the MHPA is set back from the MHPA to provide the required Brush Management Zone (BMZ) 1 area (LDC Sec. 142.0412) within the development area and outside of the MHPA. BMZ 2 may be located within the MHPA and the BMZ 2 management shall be the responsibility of a HOA or other private entity.
8. **Noise-** Due to the site's location adjacent to or within the MHPA, construction noise that exceeds the maximum levels allowed shall be avoided, during the breeding seasons for protected avian species such as: *California Gnatcatcher (3/1-8/15)*; *Least Bell's vireo (3/15-9/15)*; and *Southwestern Willow Flycatcher (5/1-8/30)*. If construction is proposed during the breeding season for the species, U.S. Fish and Wildlife Service protocol surveys shall be required in order to determine species presence/absence. When applicable, adequate noise reduction measures shall be incorporated. Upon project submittal EAS shall determine which of the following project specific avian protocol surveys shall be required.

COASTAL CALIFORNIA GNATCATCHER

NO CLEARING, GRUBBING, GRADING, OR OTHER CONSTRUCTION ACTIVITIES SHALL OCCUR BETWEEN MARCH 1 AND AUGUST 15, THE BREEDING SEASON OF THE COASTAL CALIFORNIA GNATCATCHER, UNTIL THE FOLLOWING REQUIREMENTS HAVE BEEN MET TO THE SATISFACTION OF THE CITY MANAGER:

- a. A QUALIFIED BIOLOGIST (POSSESSING A VALID ENDANGERED SPECIES ACT SECTION 10(a)(1)(A) RECOVERY PERMIT) SHALL SURVEY THOSE HABITAT AREAS WITHIN ADJACENT TO THE MHPA THAT WOULD BE SUBJECT TO CONSTRUCTION NOISE LEVELS EXCEEDING 60 DECIBELS [dB(A)] HOURLY AVERAGE FOR THE PRESENCE OF THE COASTAL CALIFORNIA GNATCATCHER. SURVEYS FOR THE COASTAL CALIFORNIA GNATCATCHER SHALL BE CONDUCTED PURSUANT TO THE PROTOCOL SURVEY GUIDELINES ESTABLISHED BY THE U.S. FISH AND WILDLIFE SERVICE WITHIN THE BREEDING SEASON PRIOR TO THE COMMENCEMENT OF ANY CONSTRUCTION. IF GNATCATCHERS ARE PRESENT, THEN THE FOLLOWING CONDITIONS MUST BE MET:

BETWEEN MARCH 1 AND AUGUST 15, NO CLEARING, GRUBBING, OR GRADING OF OCCUPIED GNATCATCHER HABITAT SHALL BE PERMITTED. AREAS RESTRICTED FROM SUCH ACTIVITIES SHALL BE STAKED OR FENCED UNDER THE SUPERVISION OF A QUALIFIED BIOLOGIST; AND

1. BETWEEN MARCH 1 AND AUGUST 15, NO CONSTRUCTION ACTIVITIES SHALL OCCUR WITHIN ANY PORTION OF THE SITE WHERE CONSTRUCTION ACTIVITIES WOULD RESULT IN NOISE LEVELS EXCEEDING 60 dB(A) HOURLY AVERAGE AT THE EDGE OF OCCUPIED GNATCATCHER HABITAT. AN ANALYSIS SHOWING THAT NOISE GENERATED BY CONSTRUCTION

ACTIVITIES WOULD NOT EXCEED 60 dB(A) HOURLY AVERAGE AT THE EDGE OF OCCUPIED HABITAT MUST BE COMPLETED BY A QUALIFIED ACOUSTICIAN (POSSESSING CURRENT NOISE ENGINEER LICENSE OR REGISTRATION WITH MONITORING NOISE LEVEL EXPERIENCE WITH LISTED ANIMAL SPECIES) AND APPROVED BY THE CITY MANAGER AT LEAST TWO WEEKS PRIOR TO THE COMMENCEMENT OF CONSTRUCTION ACTIVITIES. PRIOR TO THE COMMENCEMENT OF CONSTRUCTION ACTIVITIES DURING THE BREEDING SEASON, AREAS RESTRICTED FROM SUCH ACTIVITIES SHALL BE STAKED OR FENCED UNDER THE SUPERVISION OF A QUALIFIED BIOLOGIST; OR

2. AT LEAST TWO WEEKS PRIOR TO THE COMMENCEMENT OF CONSTRUCTION ACTIVITIES, UNDER THE DIRECTION OF A QUALIFIED ACOUSTICIAN, NOISE ATTENUATION MEASURES (e.g., BERMS, WALLS) SHALL BE IMPLEMENTED TO ENSURE THAT NOISE LEVELS RESULTING FROM CONSTRUCTION ACTIVITIES WILL NOT EXCEED 60 dB(A) HOURLY AVERAGE AT THE EDGE OF HABITAT OCCUPIED BY THE COASTAL CALIFORNIA GNATCATCHER. CONCURRENT WITH THE COMMENCEMENT OF CONSTRUCTION ACTIVITIES AND THE CONSTRUCTION OF NECESSARY NOISE ATTENUATION FACILITIES, NOISE MONITORING* SHALL BE CONDUCTED AT THE EDGE OF THE OCCUPIED HABITAT AREA TO ENSURE THAT NOISE LEVELS DO NOT EXCEED 60 dB(A) HOURLY AVERAGE. IF THE NOISE ATTENUATION TECHNIQUES IMPLEMENTED ARE DETERMINED TO BE INADEQUATE BY THE QUALIFIED ACOUSTICIAN OR BIOLOGIST, THEN THE ASSOCIATED CONSTRUCTION ACTIVITIES SHALL CEASE UNTIL SUCH TIME THAT ADEQUATE NOISE ATTENUATION IS ACHIEVED OR UNTIL THE END OF THE BREEDING SEASON (AUGUST 16).

* Construction noise monitoring shall continue to be monitored at least twice weekly on varying days, or more frequently depending on the construction activity, to verify that noise levels at the edge of occupied habitat are maintained below 60 dB(A) hourly average or to the ambient noise level if it already exceeds 60 dB(A) hourly average. If not, other measures shall be implemented in consultation with the biologist and the City Manager, as necessary, to reduce noise levels to below 60 dB(A) hourly average or to the ambient noise level if it already exceeds 60 dB(A) hourly average. Such measures may include, but are not limited to, limitations on the placement of construction equipment and the simultaneous use of equipment.

- b. IF COASTAL CALIFORNIA GNATCATCHERS ARE NOT DETECTED DURING THE PROTOCOL SURVEY, THE QUALIFIED BIOLOGIST SHALL SUBMIT SUBSTANTIAL EVIDENCE TO THE CITY MANAGER AND APPLICABLE RESOURCE AGENCIES WHICH DEMONSTRATES WHETHER OR NOT MITIGATION MEASURES SUCH AS NOISE WALLS ARE NECESSARY BETWEEN MARCH 1 AND AUGUST 15 AS FOLLOWS:

1. IF THIS EVIDENCE INDICATES THE POTENTIAL IS HIGH FOR COASTAL CALIFORNIA GNATCATCHER TO BE PRESENT BASED ON HISTORICAL RECORDS OR SITE CONDITIONS, THEN CONDITION A.III SHALL BE ADHERED TO AS SPECIFIED ABOVE.
2. IF THIS EVIDENCE CONCLUDES THAT NO IMPACTS TO THIS SPECIES ARE ANTICIPATED, NO MITIGATION MEASURES WOULD BE NECESSARY.

LEAST BELL'S VIREO (State Endangered/Federally Endangered)

NO CLEARING, GRUBBING, GRADING, OR OTHER CONSTRUCTION ACTIVITIES SHALL OCCUR BETWEEN MARCH 15 AND SEPTEMBER 15, THE BREEDING SEASON OF THE LEAST BELL'S VIREO, UNTIL THE FOLLOWING REQUIREMENTS HAVE BEEN MET TO THE SATISFACTION OF THE CITY MANAGER:

- A. A QUALIFIED BIOLOGIST (POSSESSING A VALID ENDANGERED SPECIES ACT SECTION 10(a)(1)(A) RECOVERY PERMIT) SHALL SURVEY THOSE WETLAND AREAS THAT WOULD BE SUBJECT TO CONSTRUCTION NOISE LEVELS EXCEEDING 60 DECIBELS [dB(A)] HOURLY AVERAGE FOR THE PRESENCE OF THE LEAST BELL'S VIREO. SURVEYS FOR THE THIS SPECIES SHALL BE CONDUCTED PURSUANT TO THE PROTOCOL SURVEY GUIDELINES ESTABLISHED BY THE U.S. FISH AND WILDLIFE SERVICE WITHIN THE BREEDING SEASON PRIOR TO THE COMMENCEMENT OF CONSTRUCTION. IF THE LEAST BELL'S VIREO IS PRESENT, THEN THE FOLLOWING CONDITIONS MUST BE MET:

BETWEEN MARCH 15 AND SEPTEMBER 15, NO CLEARING, GRUBBING, OR GRADING OF OCCUPIED LEAST BELL'S VIREO HABITAT SHALL BE PERMITTED. AREAS RESTRICTED FROM SUCH ACTIVITIES SHALL BE STAKED OR FENCED UNDER THE SUPERVISION OF A QUALIFIED BIOLOGIST; AND

BETWEEN MARCH 15 AND SEPTEMBER 15, NO CONSTRUCTION ACTIVITIES SHALL OCCUR WITHIN ANY PORTION OF THE SITE WHERE CONSTRUCTION ACTIVITIES WOULD RESULT IN NOISE LEVELS EXCEEDING 60 dB(A) HOURLY AVERAGE AT THE EDGE OF OCCUPIED LEAST BELL'S VIREO OR HABITAT. AN ANALYSIS SHOWING THAT NOISE GENERATED BY CONSTRUCTION ACTIVITIES WOULD NOT EXCEED 60 dB(A) HOURLY AVERAGE AT THE EDGE OF OCCUPIED HABITAT MUST BE COMPLETED BY A QUALIFIED ACOUSTICIAN (POSSESSING CURRENT NOISE ENGINEER LICENSE OR REGISTRATION WITH MONITORING NOISE LEVEL EXPERIENCE WITH LISTED ANIMAL SPECIES) AND APPROVED BY THE CITY MANAGER AT LEAST TWO WEEKS PRIOR TO THE COMMENCEMENT OF CONSTRUCTION ACTIVITIES. PRIOR TO THE COMMENCEMENT OF ANY OF CONSTRUCTION ACTIVITIES DURING THE BREEDING SEASON, AREAS RESTRICTED FROM SUCH ACTIVITIES SHALL BE STAKED OR FENCED

UNDER THE SUPERVISION OF A QUALIFIED BIOLOGIST; OR

AT LEAST TWO WEEKS PRIOR TO THE COMMENCEMENT OF CONSTRUCTION ACTIVITIES, UNDER THE DIRECTION OF A QUALIFIED ACOUSTICIAN, NOISE ATTENUATION MEASURES (e.g., BERMS, WALLS) SHALL BE IMPLEMENTED TO ENSURE THAT NOISE LEVELS RESULTING FROM CONSTRUCTION ACTIVITIES WILL NOT EXCEED 60 dB(A) HOURLY AVERAGE AT THE EDGE OF HABITAT OCCUPIED BY THE LEAST BELL'S VIREO. CONCURRENT WITH THE COMMENCEMENT OF CONSTRUCTION ACTIVITIES AND THE CONSTRUCTION OF NECESSARY NOISE ATTENUATION FACILITIES, NOISE MONITORING* SHALL BE CONDUCTED AT THE EDGE OF THE OCCUPIED HABITAT AREA TO ENSURE THAT NOISE LEVELS DO NOT EXCEED 60 dB(A) HOURLY AVERAGE. IF THE NOISE ATTENUATION TECHNIQUES IMPLEMENTED ARE DETERMINED

TO BE INADEQUATE BY THE QUALIFIED ACOUSTICIAN OR BIOLOGIST, THEN THE ASSOCIATED CONSTRUCTION ACTIVITIES SHALL CEASE UNTIL SUCH TIME THAT ADEQUATE NOISE ATTENUATION IS ACHIEVED OR UNTIL THE END OF THE BREEDING SEASON (SEPTEMBER 16).

* Construction noise monitoring shall continue to be monitored at least twice weekly on varying days, or more frequently depending on the construction activity, to verify that noise levels at the edge of occupied habitat are maintained below 60 dB(A) hourly average or to the ambient noise level if it already exceeds 60 dB(A) hourly average. If not, other measures shall be implemented in consultation with the biologist and the City Manager, as necessary, to reduce noise levels to below 60 dB(A) hourly average or to the ambient noise level if it already exceeds 60 dB(A) hourly average. Such measures may include, but are not limited to, limitations on the placement of construction equipment and the simultaneous use of equipment.

- B. IF LEAST BELL'S VIREO ARE NOT DETECTED DURING THE PROTOCOL SURVEY, THE QUALIFIED BIOLOGIST SHALL SUBMIT SUBSTANTIAL EVIDENCE TO THE CITY MANAGER AND APPLICABLE RESOURCE AGENCIES WHICH DEMONSTRATES WHETHER OR NOT MITIGATION MEASURES SUCH AS NOISE WALLS ARE NECESSARY BETWEEN MARCH 15 AND SEPTEMBER 15 AS FOLLOWS:
- I. IF THIS EVIDENCE INDICATES THE POTENTIAL IS HIGH FOR LEAST BELL'S VIREO TO BE PRESENT BASED ON HISTORICAL RECORDS OR SITE CONDITIONS, THEN CONDITION A.III SHALL BE ADHERED TO AS SPECIFIED ABOVE.
 - II. IF THIS EVIDENCE CONCLUDES THAT NO IMPACTS TO THIS SPECIES ARE ANTICIPATED, NO MITIGATION MEASURES WOULD BE NECESSARY.

SOUTHWESTERN WILLOW FLYCATCHER (Federally Endangered)

1. Prior to the first reconstruction meeting, the City Manager (or appointed designee) shall verify that the following project requirements regarding the southwestern willow flycatcher are shown on the construction plans:

NO CLEARING, GRUBBING, GRADING, OR OTHER CONSTRUCTION ACTIVITIES SHALL OCCUR BETWEEN MAY 1 AND SEPTEMBER 1, THE BREEDING SEASON OF THE SOUTHWESTERN WILLOW FLYCATCHER, UNTIL

THE FOLLOWING REQUIREMENTS HAVE BEEN MET TO THE SATISFACTION OF THE CITY MANAGER:

- A. A QUALIFIED BIOLOGIST (POSSESSING A VALID ENDANGERED SPECIES ACT SECTION 10(a)(1)(A) RECOVERY PERMIT) SHALL SURVEY THOSE WETLAND AREAS THAT WOULD BE SUBJECT TO CONSTRUCTION NOISE LEVELS EXCEEDING 60 DECIBELS [dB(A)] HOURLY AVERAGE FOR THE PRESENCE OF THE SOUTHWESTERN WILLOW FLYCATCHER. SURVEYS FOR THIS SPECIES SHALL BE CONDUCTED PURSUANT TO THE PROTOCOL SURVEY GUIDELINES ESTABLISHED BY THE U.S. FISH AND WILDLIFE SERVICE WITHIN THE BREEDING SEASON PRIOR TO THE COMMENCEMENT OF ANY CONSTRUCTION. IF THE SOUTHWESTERN WILLOW FLYCATCHER IS PRESENT, THEN THE FOLLOWING CONDITIONS MUST BE MET:

BETWEEN MAY 1 AND SEPTEMBER 1, NO CLEARING, GRUBBING, OR GRADING OF OCCUPIED SOUTHWESTERN WILLOW FLYCATCHER HABITAT SHALL BE PERMITTED. AREAS RESTRICTED FROM SUCH ACTIVITIES SHALL BE STAKED OR FENCED UNDER THE SUPERVISION OF A QUALIFIED BIOLOGIST; AND

BETWEEN MAY 1 AND SEPTEMBER 1, NO CONSTRUCTION ACTIVITIES SHALL OCCUR WITHIN ANY PORTION OF THE SITE WHERE CONSTRUCTION ACTIVITIES WOULD RESULT IN NOISE LEVELS EXCEEDING 60 dB(A) HOURLY AVERAGE AT THE EDGE OF OCCUPIED SOUTHWESTERN WILLOW FLYCATCHER HABITAT. AN ANALYSIS SHOWING THAT NOISE GENERATED BY CONSTRUCTION ACTIVITIES WOULD NOT EXCEED 60 dB(A) HOURLY AVERAGE AT THE EDGE OF OCCUPIED HABITAT MUST BE COMPLETED BY A QUALIFIED ACOUSTICIAN (POSSESSING CURRENT NOISE ENGINEER LICENSE OR REGISTRATION WITH MONITORING NOISE LEVEL EXPERIENCE WITH LISTED ANIMAL SPECIES) AND APPROVED BY THE CITY MANAGER AT LEAST TWO WEEKS PRIOR TO THE COMMENCEMENT OF CONSTRUCTION ACTIVITIES. PRIOR TO THE COMMENCEMENT OF CONSTRUCTION ACTIVITIES DURING THE BREEDING SEASON, AREAS RESTRICTED FROM SUCH ACTIVITIES SHALL BE STAKED OR FENCED UNDER THE SUPERVISION OF A QUALIFIED BIOLOGIST; OR AT LEAST TWO WEEKS PRIOR TO THE COMMENCEMENT OF CONSTRUCTION ACTIVITIES, UNDER THE DIRECTION OF A QUALIFIED ACOUSTICIAN;

NOISE ATTENUATION MEASURES (e.g., BERMS, WALLS) SHALL BE IMPLEMENTED TO ENSURE THAT NOISE LEVELS RESULTING FROM CONSTRUCTION ACTIVITIES WILL NOT EXCEED 60 dB(A) HOURLY AVERAGE AT THE EDGE OF HABITAT OCCUPIED BY THE SOUTHWESTERN WILLOW FLYCATCHER. CONCURRENT WITH THE COMMENCEMENT OF CONSTRUCTION ACTIVITIES AND THE CONSTRUCTION OF NECESSARY NOISE ATTENUATION FACILITIES, NOISE MONITORING* SHALL BE CONDUCTED AT THE EDGE OF THE OCCUPIED HABITAT AREA TO ENSURE THAT NOISE LEVELS DO NOT EXCEED 60 dB(A) HOURLY AVERAGE. IF THE NOISE ATTENUATION TECHNIQUES IMPLEMENTED ARE DETERMINED TO BE INADEQUATE BY THE QUALIFIED ACOUSTICIAN OR BIOLOGIST, THEN THE ASSOCIATED CONSTRUCTION ACTIVITIES SHALL CEASE UNTIL SUCH TIME THAT ADEQUATE NOISE ATTENUATION IS ACHIEVED OR UNTIL THE END OF THE BREEDING SEASON (SEPTEMBER 1).

* Construction noise monitoring shall continue to be monitored at least twice weekly on varying days, or more frequently depending on the construction activity, to verify that noise levels at the edge of occupied habitat are maintained below 60 dB(A) hourly average or to the ambient noise level if it already exceeds 60 dB(A) hourly average. If not, other measures shall be implemented in consultation with the biologist and the City Manager, as necessary, to reduce noise levels to below 60 dB(A) hourly average or to the ambient noise level if it already exceeds 60 dB(A) hourly average. Such measures may include, but are not limited to, limitations on the placement of construction equipment and the simultaneous use of equipment.

- B. IF SOUTHWESTERN WILLOW FLYCATCHER ARE NOT DETECTED DURING THE PROTOCOL SURVEY, THE QUALIFIED BIOLOGIST SHALL SUBMIT SUBSTANTIAL EVIDENCE TO THE CITY MANAGER AND APPLICABLE RESOURCE AGENCIES WHICH DEMONSTRATES WHETHER OR NOT MITIGATION MEASURES SUCH AS NOISE WALLS ARE NECESSARY BETWEEN MAY 1 AND SEPTEMBER 1 AS FOLLOWS:
 - I. IF THIS EVIDENCE INDICATES THE POTENTIAL IS HIGH FOR SOUTHWESTERN WILLOW FLYCATCHER TO BE PRESENT BASED ON HISTORICAL RECORDS OR SITE CONDITIONS, THEN CONDITION A.III SHALL BE ADHERED TO AS SPECIFIED ABOVE.
 - II. IF THIS EVIDENCE CONCLUDES THAT NO IMPACTS TO THIS SPECIES ARE ANTICIPATED, NO MITIGATION MEASURES WOULD BE NECESSARY.

II. Prior to Start of Construction

A. Preconstruction Meeting

The Qualified Biologist/Owners Representative shall incorporate all MHPA construction related requirements, into the project's Biological Monitoring Exhibit (BME).

The Qualified Biologist/Owners Representative is responsible to arrange and perform a focused pre-con with all contractors, subcontractors, and all workers involved in grading or other construction activities that discusses the sensitive nature of the adjacent sensitive biological resources.

III. During Construction

- A. The Qualified Biologist/Owners Representative, shall verify that all construction related activities taking place ~~within or~~ adjacent to the MHPA are consistent with the CDs, the MSCP/MHPA Land Use Adjacency Guidelines. The Qualified Biologist/Owners Representative shall monitor and ensure that:
1. **Land Development /Grading Boundaries** - The MHPA boundary and the limits of grading shall be clearly delineated by a survey crew prior to brushing, clearing, or grading. Limits shall be defined with orange construction fence and a siltation fence (can be combined) under the supervision of the Qualified Biologist/Owners Representative who shall provide a letter of verification to RE/MMC that all limits were marked as required. ~~Within or a~~Adjacent to the MHPA, all manufactured slopes associated with site development shall be included within the development footprint.
 2. **Drainage/Toxics** - No Direct drainage into the MHPA shall occur during or after construction and that filtration devices, swales and/or detention/desiltation basins that drain into the MHPA are functioning properly during construction, and that permanent maintenance after construction is addressed. These systems should be maintained approximately once a year, or as often a needed, to ensure proper functioning. Maintenance should include dredging out sediments if needed, removing exotic plant materials, and adding chemical-neutralizing compounds (e.g. clay compounds) when necessary and appropriate.
 3. **Staging/storage, equipment maintenance, and trash** - Identify all areas for staging, storage of equipment and materials, trash, equipment maintenance, and other construction related activities on the monitoring exhibits and verify that they are within the development footprint. Comply with the applicable notes on the plans
 4. **Barriers** - New development adjacent to the MHPA provides city approved barriers along the MHPA boundaries
 5. **Lighting** - Periodic night inspections are performed to verify that all lighting adjacent to the MHPA is directed away from preserve areas and appropriate placement and shielding is used.
 6. **Invasives** - No invasive plant species are used ~~in or~~ adjacent (within 100 feet) to the MHPA ~~and that within the MHPA, all plant species must be native.~~
 7. **Brush Management** - BMZ1 is within the development footprint and outside of the MHPA, and that maintenance responsibility for the BMZ 2 located within the MHPA is identified as the responsibility of an HOA or other private entity.
 8. **Noise** - For any area of the site that is adjacent to ~~or within~~ the MHPA, construction noise that exceeds the maximum levels allowed, shall be avoided, during the breeding seasons, for protected avian species such as: *California Gnatcatcher (3/1-8/15)*; *Least Bell's vireo (3/15-9/15)*; and *Southwestern Willow Flycatcher (5/1-8/30)*. If construction is proposed during the breeding season for the species, U.S. Fish and Wildlife Service protocol surveys will be required in order to determine species presence/absence. When applicable, adequate noise reduction measures shall

be incorporated.

IV. Post Construction

A. Preparation and Submittal of Monitoring Report

The Qualified Biologist/Owners Representative shall submit a final biological monitoring report to the RE/MMC within 30 days of the completion of construction that requires monitoring. The report shall incorporate the results of the MMRP/MSCP requirements per the construction documents and the BME to the satisfaction of RE/MMC.

B. HISTORICAL RESOURCES (ARCHAEOLOGY)

Prior to Permit Issuance or Bid Opening/Bid Award

A. Entitlements Plan Check

1. Prior to permit issuance or Bid Opening/Bid Award, whichever is applicable, the Assistant Deputy Director (ADD) Environmental designee shall verify that the requirements for Archaeological Monitoring and Native American monitoring have been noted on the applicable construction documents through the plan check process.

B. Letters of Qualification have been submitted to ADD

1. Prior to Bid Award, the applicant shall submit a letter of verification to Mitigation Monitoring Coordination (MMC) identifying the Principal Investigator (PI) for the project and the names of all persons involved in the archaeological monitoring program, as defined in the City of San Diego Historical Resources Guidelines (HRG). If applicable, individuals involved in the archaeological monitoring program must have completed the 40-hour HAZWOPER training with certification documentation.
2. MMC will provide a letter to the applicant confirming the qualifications of the PI and all persons involved in the archaeological monitoring of the project meet the qualifications established in the HRG.
3. Prior to the start of work, the applicant must obtain written approval from MMC for any personnel changes associated with the monitoring program.

II. Prior to Start of Construction

A. Verification of Records Search

1. The PI shall provide verification to MMC that a site specific records search (1/4 mile radius) has been completed. Verification includes, but is not limited to a copy of a confirmation letter from South Coastal Information Center, or, if the search was in-house, a letter of verification from the PI stating that the search was completed.
2. The letter shall introduce any pertinent information concerning expectations and probabilities of discovery during trenching and/or grading activities.
3. The PI may submit a detailed letter to MMC requesting a reduction to the ¼ mile radius.

B. PI Shall Attend Precon Meetings

1. Prior to beginning any work that requires monitoring; the Applicant shall arrange a Precon Meeting that shall include the PI, Native American consultant/monitor (where Native American resources may be impacted), Construction Manager (CM)

and/or Grading Contractor, Resident Engineer (RE), Building Inspector (BI), if appropriate, and MMC. The qualified Archaeologist and Native American Monitor shall attend any grading/excavation related Precon Meetings to make comments and/or suggestions concerning the Archaeological Monitoring program with the Construction Manager and/or Grading Contractor.

- a. If the PI is unable to attend the Precon Meeting, the Applicant shall schedule a focused Precon Meeting with MMC, the PI, RE, CM or BI, if appropriate, prior to the start of any work that requires monitoring.
2. Acknowledgement of Responsibility for Curation (CIP or Other Public Projects)
The applicant shall submit a letter to MMC acknowledging their responsibility for the cost of curation associated with all phases of the archaeological monitoring program.
 3. Identify Areas to be Monitored
 - b. Prior to the start of any work that requires monitoring, the PI shall submit an Archaeological Monitoring Exhibit (AME) (with verification that the AME has been reviewed and approved by the Native American consultant/monitor when Native American resources may be impacted) based on the appropriate construction documents (reduced to 11x17) to MMC identifying the areas to be monitored including the delineation of grading/excavation limits.
 - c. The AME shall be based on the results of a site specific records search as well as information regarding the age of existing pipelines, laterals and associated appurtenances and/or any known soil conditions (native or formation).
 - d. MMC shall notify the PI that the AME has been approved.
 4. When Monitoring Will Occur
 - a. Prior to the start of any work, the PI shall also submit a construction schedule to MMC through the RE indicating when and where monitoring will occur.
 - b. The PI may submit a detailed letter to MMC prior to the start of work or during construction requesting a modification to the monitoring program. This request shall be based on relevant information such as review of final construction documents which indicate conditions such as age of existing pipe to be replaced, depth of excavation and/or site graded to bedrock, etc., which may reduce or increase the potential for resources to be present.
 5. Approval of AME and Construction Schedule
After approval of the AME by MMC, the PI shall submit to MMC written authorization of the AME and Construction Schedule from the CM.

III. During Construction

- A. Monitor Shall be Present During Grading/Excavation/Trenching
 1. The Archaeological Monitor shall be present full-time during all soil disturbing and grading/excavation/trenching activities which could result in impacts to archaeological resources as identified on the AME. **The Construction Manager is responsible for notifying the RE, PI, and MMC of changes to any construction activities such as in the case of a potential safety concern within the area being monitored. In certain circumstances OSHA safety requirements may necessitate modification of the AME.**
 2. The Native American consultant/monitor shall determine the extent of their presence during soil disturbing and grading/excavation/trenching activities based on the AME and provide that information to the PI and MMC. If prehistoric resources are

encountered during the Native American consultant/monitor's absence, work shall stop and the Discovery Notification Process detailed in Section III.B-C and IV.A-D shall commence.

3. The PI may submit a detailed letter to MMC during construction requesting a modification to the monitoring program when a field condition such as modern disturbance post-dating the previous grading/trenching activities, presence of fossil formations, or when native soils are encountered that may reduce or increase the potential for resources to be present.
4. The archaeological and Native American consultant/monitor shall document field activity via the Consultant Site Visit Record (CSV). The CSV's shall be faxed by the CM to the RE the first day of monitoring, the last day of monitoring, monthly (**Notification of Monitoring Completion**), and in the case of ANY discoveries. The RE shall forward copies to MMC.

B. Discovery Notification Process

1. In the event of a discovery, the Archaeological Monitor shall direct the contractor to temporarily divert all soil disturbing activities, including but not limited to digging, trenching, excavating or grading activities in the area of discovery and in the area reasonably suspected to overlay adjacent resources and immediately notify the RE or BI, as appropriate.
2. The Monitor shall immediately notify the PI (unless Monitor is the PI) of the discovery.
3. The PI shall immediately notify MMC by phone of the discovery, and shall also submit written documentation to MMC within 24 hours by fax or email with photos of the resource in context, if possible.
4. No soil shall be exported off-site until a determination can be made regarding the significance of the resource specifically if Native American resources are encountered.

C. Determination of Significance

1. The PI and Native American consultant/monitor, where Native American resources are discovered shall evaluate the significance of the resource. If Human Remains are involved, follow protocol in Section IV below.
 - a. The PI shall immediately notify MMC by phone to discuss significance determination and shall also submit a letter to MMC indicating whether additional mitigation is required.
 - b. If the resource is significant, the PI shall submit an Archaeological Data Recovery Program (ADRP) and obtain written approval of the program from MMC, CM and RE. ADRP and any mitigation must be approved by MMC, RE and/or CM before ground disturbing activities in the area of discovery will be allowed to resume. **Note: If a unique archaeological site is also an historical resource as defined in CEQA Section 15064.5, then the limits on the amount(s) that a project applicant may be required to pay to cover mitigation costs as indicated in CEQA Section 21083.2 shall not apply.**
 - (1). Note: For pipeline trenching and other linear projects in the public Right-of-Way, the PI shall implement the Discovery Process for Pipeline Trenching projects identified below under "D."
 - c. If the resource is not significant, the PI shall submit a letter to MMC indicating that artifacts will be collected, curated, and documented in the Final Monitoring Report. The letter shall also indicate that that no further work is required.

- (1). Note: For Pipeline Trenching and other linear projects in the public Right-of-Way, if the deposit is limited in size, both in length and depth; the information value is limited and is not associated with any other resource; and there are no unique features/artifacts associated with the deposit, the discovery should be considered not significant.
- (2). Note, for Pipeline Trenching and other linear projects in the public Right-of-Way, if significance cannot be determined, the Final Monitoring Report and Site Record (DPR Form 523A/B) shall identify the discovery as Potentially Significant.

D. Discovery Process for Significant Resources - Pipeline Trenching and other Linear Projects in the Public Right-of-Way

The following procedure constitutes adequate mitigation of a significant discovery encountered during pipeline trenching activities or for other linear project types within the Public Right-of-Way including but not limited to excavation for jacking pits, receiving pits, laterals, and manholes to reduce impacts to below a level of significance:

1. Procedures for documentation, curation and reporting
 - a. One hundred percent of the artifacts within the trench alignment and width shall be documented in-situ, to include photographic records, plan view of the trench and profiles of side walls, recovered, photographed after cleaning and analyzed and curated. The remainder of the deposit within the limits of excavation (trench walls) shall be left intact.
 - b. The PI shall prepare a Draft Monitoring Report and submit to MMC via the RE as indicated in Section VI-A.
 - c. The PI shall be responsible for recording (on the appropriate State of California Department of Park and Recreation forms-DPR 523 A/B) the resource(s) encountered during the Archaeological Monitoring Program in accordance with the City's Historical Resources Guidelines. The DPR forms shall be submitted to the South Coastal Information Center for either a Primary Record or SDI Number and included in the Final Monitoring Report.
 - d. The Final Monitoring Report shall include a recommendation for monitoring of any future work in the vicinity of the resource.

IV. Discovery of Human Remains

If human remains are discovered, work shall halt in that area and no soil shall be exported off-site until a determination can be made regarding the provenance of the human remains; and the following procedures as set forth in CEQA Section 15064.5(e), the California Public Resources Code (Sec. 5097.98) and State Health and Safety Code (Sec. 7050.5) shall be undertaken:

A. Notification

1. Archaeological Monitor shall notify the RE or BI as appropriate, MMC, and the PI, if the Monitor is not qualified as a PI. MMC will notify the appropriate Senior Planner in the Environmental Analysis Section (EAS) of the Development Services Department to assist with the discovery notification process.
2. The PI shall notify the Medical Examiner after consultation with the RE, either in person or via telephone.

B. Isolate discovery site

1. Work shall be directed away from the location of the discovery and any nearby area reasonably suspected to overlay adjacent human remains until a determination can

be made by the Medical Examiner in consultation with the PI concerning the provenience of the remains.

2. The Medical Examiner, in consultation with the PI, will determine the need for a field examination to determine the provenience.
 3. If a field examination is not warranted, the Medical Examiner will determine with input from the PI, if the remains are or are most likely to be of Native American origin.
- C. If Human Remains **ARE** determined to be Native American
1. The Medical Examiner will notify the Native American Heritage Commission (NAHC) within 24 hours. By law, **ONLY** the Medical Examiner can make this call.
 2. NAHC will immediately identify the person or persons determined to be the Most Likely Descendent (MLD) and provide contact information.
 3. The MLD will contact the PI within 24 hours or sooner after the Medical Examiner has completed coordination, to begin the consultation process in accordance with CEQA Section 15064.5(e), the California Public Resources and Health & Safety Codes.
 4. The MLD will have 48 hours to make recommendations to the property owner or representative, for the treatment or disposition with proper dignity, of the human remains and associated grave goods.
 5. Disposition of Native American Human Remains will be determined between the MLD and the PI, and, if:
 - a. The NAHC is unable to identify the MLD, OR the MLD failed to make a recommendation within 48 hours after being notified by the Commission, OR;
 - b. The landowner or authorized representative rejects the recommendation of the MLD and mediation in accordance with PRC 5097.94 (k) by the NAHC fails to provide measures acceptable to the landowner, THEN
 - c. To protect these sites, the landowner shall do one or more of the following:
 - (1) Record the site with the NAHC;
 - (2) Record an open space or conservation easement; or
 - (3) Record a document with the County.
 - d. Upon the discovery of multiple Native American human remains during a ground disturbing land development activity, the landowner may agree that additional conferral with descendants is necessary to consider culturally appropriate treatment of multiple Native American human remains. Culturally appropriate treatment of such a discovery may be ascertained from review of the site utilizing cultural and archaeological standards. Where the parties are unable to agree on the appropriate treatment measures the human remains and items associated and buried with Native American human remains shall be reinterred with appropriate dignity, pursuant to Section 5.c., above.
- D. If Human Remains are **NOT** Native American
1. The PI shall contact the Medical Examiner and notify them of the historic era context of the burial.
 2. The Medical Examiner will determine the appropriate course of action with the PI and City staff (PRC 5097.98).
 3. If the remains are of historic origin, they shall be appropriately removed and conveyed to the San Diego Museum of Man for analysis. The decision for internment of the human remains shall be made in consultation with MMC, EAS, the applicant/landowner, any known descendant group, and the San Diego Museum of Man.

V. Night and/or Weekend Work

- A. If night and/or weekend work is included in the contract
1. When night and/or weekend work is included in the contract package, the extent and timing shall be presented and discussed at the precon meeting.
 2. The following procedures shall be followed.
 - a. No Discoveries
In the event that no discoveries were encountered during night and/or weekend work, the PI shall record the information on the CSVR and submit to MMC via fax by 8AM of the next business day.
 - b. Discoveries
All discoveries shall be processed and documented using the existing procedures detailed in Sections III - During Construction, and IV – Discovery of Human Remains. Discovery of human remains shall always be treated as a significant discovery.
 - c. Potentially Significant Discoveries
If the PI determines that a potentially significant discovery has been made, the procedures detailed under Section III - During Construction and IV-Discovery of Human Remains shall be followed.
 - d. The PI shall immediately contact the RE and MMC, or by 8AM of the next business day to report and discuss the findings as indicated in Section III-B, unless other specific arrangements have been made.
- B. If night and/or weekend work becomes necessary during the course of construction
1. The Construction Manager shall notify the RE, or BI, as appropriate, a minimum of 24 hours before the work is to begin.
 2. The RE, or BI, as appropriate, shall notify MMC immediately.
- C. All other procedures described above shall apply, as appropriate.

VI. Post Construction

- A. Submittal of Draft Monitoring Report
1. The PI shall submit two copies of the Draft Monitoring Report (even if negative), prepared in accordance with the Historical Resources Guidelines (Appendix C/D) which describes the results, analysis, and conclusions of all phases of the Archaeological Monitoring Program (with appropriate graphics) to MMC via the RE for review and approval within 90 days following the completion of monitoring. **It should be noted that if the PI is unable to submit the Draft Monitoring Report within the allotted 90-day timeframe as a result of delays with analysis, special study results or other complex issues, a schedule shall be submitted to MMC establishing agreed due dates and the provision for submittal of monthly status reports until this measure can be met.**
 - a. For significant archaeological resources encountered during monitoring, the Archaeological Data Recovery Program or Pipeline Trenching Discovery Process shall be included in the Draft Monitoring Report.
 - b. Recording Sites with State of California Department of Parks and Recreation
The PI shall be responsible for recording (on the appropriate State of California Department of Park and Recreation forms-DPR 523 A/B) any significant or potentially significant resources encountered during the Archaeological Monitoring Program in accordance with the City's Historical Resources Guidelines, and submittal of such forms to the South Coastal Information Center with the Final Monitoring Report.

2. MMC shall return the Draft Monitoring Report to the PI via the RE for revision or, for preparation of the Final Report.
 3. The PI shall submit revised Draft Monitoring Report to MMC via the RE for approval.
 4. MMC shall provide written verification to the PI of the approved report.
 5. MMC shall notify the RE or BI, as appropriate, of receipt of all Draft Monitoring Report submittals and approvals.
- B. Handling of Artifacts
1. The PI shall be responsible for ensuring that all cultural remains collected are cleaned and catalogued
 2. The PI shall be responsible for ensuring that all artifacts are analyzed to identify function and chronology as they relate to the history of the area; that faunal material is identified as to species; and that specialty studies are completed, as appropriate.
- C. Curation of artifacts: Accession Agreement and Acceptance Verification
1. The PI shall be responsible for ensuring that all artifacts associated with the survey, testing and/or data recovery for this project are permanently curated with an appropriate institution. This shall be completed in consultation with MMC and the Native American representative, as applicable.
 2. When applicable to the situation, the PI shall include written verification from the Native American consultant/monitor indicating that Native American resources were treated in accordance with state law and/or applicable agreements. If the resources were reinterred, verification shall be provided to show what protective measures were taken to ensure no further disturbance occurs in accordance with Section IV – Discovery of Human Remains, Subsection C.
 3. The PI shall submit the Accession Agreement and catalogue record(s) to the RE or BI, as appropriate for donor signature with a copy submitted to MMC.
 4. The RE or BI, as appropriate shall obtain signature on the Accession Agreement and shall return to PI with copy submitted to MMC.
 5. The PI shall include the Acceptance Verification from the curation institution in the Final Monitoring Report submitted to the RE or BI and MMC.
- D. Final Monitoring Report(s)
1. The PI shall submit one copy of the approved Final Monitoring Report to the RE or BI as appropriate, and one copy to MMC (even if negative), within 90 days after notification from MMC of the approved report.
 2. The RE shall, in no case, issue the Notice of Completion until receiving a copy of the approved Final Monitoring Report from MMC which includes the Acceptance Verification from the curation institution.

C. PALEONTOLOGICAL RESOURCES

I. **Prior to Permit Issuance or Bid Opening/Bid Award**

A. Entitlements Plan Check

1. Prior to permit issuance or Bid Opening/Bid Award, whichever is applicable, the Assistant Deputy Director (ADD) Environmental designee shall verify that the requirements for Paleontological Monitoring have been noted on the appropriate construction documents.

B. Letters of Qualification have been submitted to ADD

1. Prior to Bid Award, the applicant shall submit a letter of verification to Mitigation Monitoring Coordination (MMC) identifying the Principal Investigator (PI) for the

project and the names of all persons involved in the paleontological monitoring program, as defined in the City of San Diego Paleontology Guidelines.

2. MMC will provide a letter to the applicant confirming the qualifications of the PI and all persons involved in the paleontological monitoring of the project.
3. Prior to the start of work, the applicant shall obtain approval from MMC for any personnel changes associated with the monitoring program.

II. Prior to Start of Construction

A. Verification of Records Search

1. The PI shall provide verification to MMC that a site specific records search has been completed. Verification includes, but is not limited to a copy of a confirmation letter from San Diego Natural History Museum, other institution or, if the search was in-house, a letter of verification from the PI stating that the search was completed.
2. The letter shall introduce any pertinent information concerning expectations and probabilities of discovery during trenching and/or grading activities.

B. PI Shall Attend Precon Meetings

1. Prior to beginning any work that requires monitoring, the Applicant shall arrange a Precon Meeting that shall include the PI, Construction Manager (CM) and/or Grading Contractor, Resident Engineer (RE), Building Inspector (BI), if appropriate, and MMC. The qualified paleontologist shall attend any grading/excavation related Precon Meetings to make comments and/or suggestions concerning the Paleontological Monitoring program with the Construction Manager and/or Grading Contractor.
 - a. If the PI is unable to attend the Precon Meeting, the Applicant shall schedule a focused Precon Meeting with MMC, the PI, RE, CM or BI, if appropriate, prior to the start of any work that requires monitoring.
2. Acknowledgement of Responsibility for Curation (CIP or Other Public Projects)
The applicant shall submit a letter to MMC acknowledging their responsibility for the cost of curation associated with all phases of the paleontological monitoring program.
3. Identify Areas to be Monitored
 - a. a. Prior to the start of any work that requires monitoring, the PI shall submit a Paleontological Monitoring Exhibit (PME) based on the appropriate construction documents (reduced to 11x17) to MMC for approval identifying the areas to be monitored including the delineation of grading/excavation limits. Monitoring shall begin at depths below 10 feet from existing grade or as determined by the PI in consultation with MMC. The determination shall be based on site specific records search data which supports monitoring at depths less than ten feet.
 - b. b. The PME shall be based on the results of a site specific records search as well as information regarding existing known soil conditions (native or formation).
 - c. c. MMC shall notify the PI that the PME has been approved.
- d. 4. When Monitoring Will Occur
 - a. Prior to the start of any work, the PI shall also submit a construction schedule to MMC through the RE indicating when and where monitoring will occur.
 - b. The PI may submit a detailed letter to MMC prior to the start of work or during construction requesting a modification to the monitoring program. This request shall be based on relevant information such as review of final construction

documents which indicate conditions such as depth of excavation and/or site graded to bedrock, presence or absence of fossil resources, etc., which may reduce or increase the potential for resources to be present.

5. Approval of PME and Construction Schedule
After approval of the PME by MMC, the PI shall submit to MMC written authorization of the PME and Construction Schedule from the CM.

III. During Construction

A. Monitor Shall be Present During Grading/Excavation/Trenching

1. The monitor shall be present full-time during grading/excavation/trenching activities including, but not limited to mainline, laterals, jacking and receiving pits, services and all other appurtenances associated with underground utilities as identified on the PME that could result in impacts to formations with high and/or moderate resource sensitivity. **The Construction Manager is responsible for notifying the RE, PI, and MMC of changes to any construction activities such as in the case of a potential safety concern within the area being monitored. In certain circumstances OSHA safety requirements may necessitate modification of the PME.**
2. The PI may submit a detailed letter to MMC during construction requesting a modification to the monitoring program when a field condition such as trenching activities that do not encounter formational soils as previously assumed, and/or when unique/unusual fossils are encountered, which may reduce or increase the potential for resources to be present.
3. The monitor shall document field activity via the Consultant Site Visit Record (CSV). The CSV's shall be faxed by the CM to the RE the first day of monitoring, the last day of monitoring, monthly (**Notification of Monitoring Completion**), and in the case of ANY discoveries. The RE shall forward copies to MMC.

B. Discovery Notification Process

1. In the event of a discovery, the Paleontological Monitor shall direct the contractor to temporarily divert trenching activities in the area of discovery and immediately notify the RE or BI, as appropriate.
2. The Monitor shall immediately notify the PI (unless Monitor is the PI) of the discovery.
3. The PI shall immediately notify MMC by phone of the discovery, and shall also submit written documentation to MMC within 24 hours by fax or email with photos of the resource in context, if possible.

C. Determination of Significance

1. The PI shall evaluate the significance of the resource.
 - a. The PI shall immediately notify MMC by phone to discuss significance determination and shall also submit a letter to MMC indicating whether additional mitigation is required. The determination of significance for fossil discoveries shall be at the discretion of the PI.
 - b. If the resource is significant, the PI shall submit a Paleontological Recovery Program (PRP) and obtain written approval of the program from MMC, MC and/or RE. PRP and any mitigation must be approved by MMC, RE and/or CM before ground disturbing activities in the area of discovery will be allowed to resume.

- (1). Note: For pipeline trenching projects only, the PI shall implement the Discovery Process for Pipeline Trenching projects identified below under "D."
 - c. If resource is not significant (e.g., small pieces of broken common shell fragments or other scattered common fossils) the PI shall notify the RE, or BI as appropriate, that a non-significant discovery has been made. The Paleontologist shall continue to monitor the area without notification to MMC unless a significant resource is encountered.
 - d. The PI shall submit a letter to MMC indicating that fossil resources will be collected, curated, and documented in the Final Monitoring Report. The letter shall also indicate that no further work is required.
 - (1). Note: For Pipeline Trenching Projects Only. If the fossil discovery is limited in size, both in length and depth; the information value is limited and there are no unique fossil features associated with the discovery area, then the discovery should be considered not significant.
 - (2). Note, for Pipeline Trenching Projects Only: If significance can not be determined, the Final Monitoring Report and Site Record shall identify the discovery as Potentially Significant.
- D. Discovery Process for Significant Resources - Pipeline Trenching Projects
- The following procedure constitutes adequate mitigation of a significant discovery encountered during pipeline trenching activities including but not limited to excavation for jacking pits, receiving pits, laterals, and manholes to reduce impacts to below a level of significance.
1. Procedures for documentation, curation and reporting
 - a. One hundred percent of the fossil resources within the trench alignment and width shall be documented in-situ photographically, drawn in plan view (trench and profiles of side walls), recovered from the trench and photographed after cleaning, then analyzed and curated consistent with Society of Invertebrate Paleontology Standards. The remainder of the deposit within the limits of excavation (trench walls) shall be left intact and so documented.
 - b. The PI shall prepare a Draft Monitoring Report and submit to MMC via the RE as indicated in Section VI-A.
 - c. The PI shall be responsible for recording (on the appropriate forms for the San Diego Natural History Museum) the resource(s) encountered during the Paleontological Monitoring Program in accordance with the City's Paleontological Guidelines. The forms shall be submitted to the San Diego Natural History Museum and included in the Final Monitoring Report.
 - d. The Final Monitoring Report shall include a recommendation for monitoring of any future work in the vicinity of the resource.

IV. Night and/or Weekend Work

- A. If night and/or weekend work is included in the contract
 1. When night and/or weekend work is included in the contract package, the extent and timing shall be presented and discussed at the precon meeting.
 2. The following procedures shall be followed.
 - a. No Discoveries

In the event that no discoveries were encountered during night and/or weekend work, The PI shall record the information on the CSVr and submit to MMC via the RE via fax by 8AM on the next business day.

- b. Discoveries
All discoveries shall be processed and documented using the existing procedures detailed in Sections III - During Construction.
 - c. Potentially Significant Discoveries
If the PI determines that a potentially significant discovery has been made, the procedures detailed under Section III - During Construction shall be followed.
 - d. The PI shall immediately contact the RE and MMC, or by 8AM on the next business day to report and discuss the findings as indicated in Section III-B, unless other specific arrangements have been made.
- B. If night and/or weekend work becomes necessary during the course of construction
 - 1. The Construction Manager shall notify the RE, or BI, as appropriate, a minimum of 24 hours before the work is to begin.
 - 2. The RE, or BI, as appropriate, shall notify MMC immediately.
 - C. All other procedures described above shall apply, as appropriate.

V. Post Construction

- A. Preparation and Submittal of Draft Monitoring Report
 - 1. The PI shall submit two copies of the Draft Monitoring Report (even if negative), prepared in accordance with the Paleontological Guidelines which describes the results, analysis, and conclusions of all phases of the Paleontological Monitoring Program (with appropriate graphics) to MMC via the RE for review and approval within 90 days following the completion of monitoring,
 - a. For significant paleontological resources encountered during monitoring, the Paleontological Recovery Program or Pipeline Trenching Discovery Process shall be included in the Draft Monitoring Report.
 - b. Recording Sites with the San Diego Natural History Museum
The PI shall be responsible for recording (on the appropriate forms) any significant or potentially significant fossil resources encountered during the Paleontological Monitoring Program in accordance with the City's Paleontological Guidelines, and submittal of such forms to the San Diego Natural History Museum with the Final Monitoring Report.
 - 2. MMC shall return the Draft Monitoring Report to the PI via the RE for revision or, for preparation of the Final Report.
 - 3. The PI shall submit revised Draft Monitoring Report to MMC via the RE for approval.
 - 4. MMC shall provide written verification to the PI of the approved report.
 - 5. MMC shall notify the RE or BI, as appropriate, of receipt of all Draft Monitoring Report submittals and approvals.
- B. Handling of Fossil Remains
 - 1. The PI shall be responsible for ensuring that all fossil remains collected are cleaned and catalogued.
- C. Curation of artifacts: Deed of Gift and Acceptance Verification
 - 1. The PI shall be responsible for ensuring that all fossil remains associated with the monitoring for this project are permanently curated with an appropriate institution.
 - 2. The PI shall submit the Deed of Gift and catalogue record(s) to the RE or BI, as appropriate for donor signature with a copy submitted to MMC.
 - 3. The RE or BI, as appropriate shall obtain signature on the Deed of Gift and shall return to PI with copy submitted to MMC.

4. The PI shall include the Acceptance Verification from the curation institution in the Final Monitoring Report submitted to the RE or BI and MMC.
- D. Final Monitoring Report(s)
1. The PI shall submit two copies of the Final Monitoring Report to MMC (even if negative), within 90 days after notification from MMC of the approved report.
 2. The RE shall, in no case, issue the Notice of Completion until receiving a copy of the approved Final Monitoring Report from MMC which includes the Acceptance Verification from the curation institution.

D. HISTORICAL RESOURCES (BUILT ENVIRONMENT)

When a future project requires implementation of this mitigation measure, the following paragraph shall be included in the subsequent environmental document and applicable Historic District name, boundary and district guidelines, if applicable shall be inserted as noted below in [brackets]:

The project is located within the [[insert District name]] Historic District, bounded by [[enter District boundary]] All work within the District boundary must be consistent with the City's Historical Resources Regulations, the U.S. Secretary of the Interior's Standards and the [[enter district guidelines if applicable]] District Design Guidelines. The following mitigation measures are required within the District boundary and shall ensure consistency with these regulations, Standards and guidelines.

- A. Prior to beginning any work at the site, a Pre Construction meeting that includes Historic Resources and MMC staff shall be held at the project site to review these mitigation measures and requirements within the District boundary.
- B. A Historic Sidewalk Stamp Inventory prepared by a qualified historic consultant or archaeologist and approved by HRB staff is required prior to the Pre-Construction (Pre-Con) meeting. The Inventory shall include photo documentation of all existing stamps within the project area keyed to a project site plan.
- C. Existing sidewalk stamps shall be preserved in place. Where existing sidewalk stamps must be impacted to accommodate right-of-way improvements, the following actions are required:
 1. A mold of the sidewalk stamp will be made to allow reconstruction of the stamp if destroyed during relocation.
 2. The sidewalk stamp shall be saw-cut to preserve the stamp in its entirety; relocated as near as possible to the original location; and set in the same orientation.
 3. If the sidewalk stamp is destroyed during relocation, a new sidewalk stamp shall be made from the mold taken and relocated as near as possible to the original location and set in the same orientation.
- D. No new sidewalk stamps shall be added by any contractor working on the project.
- E. Existing historic sidewalk, parkway and street widths shall be maintained. Any work that requires alteration of these widths shall be approved by Historic Resources staff.
- F. Existing historic curb heights and appearance shall be maintained. Any work that requires alteration of the existing height or appearance shall be approved by Historic Resources staff.

- G. Sections of sidewalk which may be impacted by the project shall be replaced in-kind to match the historic color, texture and scoring pattern of the original sidewalks. If the original color, scoring pattern or texture is not present at the location of the impact, the historically appropriate color, texture and scoring pattern found throughout the district shall be used.
- H. Truncated domes used at corner curb ramps shall be dark gray in color.
- I. Existing historic lighting, such as acorn lighting shall remain. New lighting shall be consistent with existing lighting fixtures, or fixtures specified in any applicable District Design Guidelines.
- J. Existing mature street trees shall remain. New street trees shall be consistent with the prevalent mature species in the District and/or species specified in any applicable District Design Guidelines.
- K. Any walls located within the right-of-way or on private property are considered historic and may not be impacted without prior review and approval by Historic Resources staff.

VI. PUBLIC REVIEW DISTRIBUTION:

Draft copies or notice of this Mitigated Negative Declaration were distributed to:

United States Government

- Fish and Wildlife Service (23)
- MCAS Miramar (13)
- Naval Facilities Engineering Command Southwest (8)

State of California

- Department of Fish and Game (32A)
- State Clearing House (46)
- Resources Agency (43)
- Native American Heritage Commission (56)
- State Historic Preservation Officer (41)
- Regional Water Quality Control Board (44)
- Water Resources (45)
- Water Resources Control Board (55)
- Coastal Commission (48)
- Caltrans District 11 (31)

County of San Diego

- Department of Environmental Health (75)
- Planning and Land Use (68)
- Water Authority (73)

City of San Diego

- Office of the Mayor (91)
- Council President Young, District 4 (MS 10A)
- Councilmember Lightner, District 1 (MS 10A)
- Councilmember Faulconer, District 2 (MS 10A)
- Councilmember Gloria, District 3 (MS 10A)
- Councilmember DeMaio, District 5 (MS 10A)

Councilmember Zapf, District 6 (MS 10A)
Councilmember Emerald, District 7 (MS 10A)
Councilmember Alvarez, District 8 (MS 10A)
Historical Resource Board (87)
City Attorney (MS 56A)
 Shannon Thomas (MS 93C)
Engineering and Capital Projects
 Marc Cass (MS 908A)
 Allison Sherwood (MS 908A)
 Matthew DeBeliso (MS 908A)
 Akram Bassyouni (MS 908A)
 Michael Ninh (MS 908A)
 Roman Anissi (MS 908A)
 Daniel Tittle (MS 908A)
Development Services Department
 Myra Herrmann (MS 501)
 Kristen Forburger (MS 401)
 Jeanne Krosch (MS 401)
 Kelley Stanco (MS 501)
Library Dept.-Gov. Documents MS 17 (81)
 Balboa Branch Library (81B)
 Beckwourth Branch Library (81C)
 Benjamin Branch Library (81D)
 Carmel Mountain Ranch Branch (81E)
 Carmel Valley Branch Library (81F)
 City Heights/Weingart Branch Library (81G)
 Clairemont Branch Library (81H)
 College-Rolando Branch Library (81I)
 Kensington-Normal Heights Branch Library (81K)
 La Jolla/Riford branch Library (81L)
 Linda Vista Branch Library (81M)
 Logan Heights Branch Library (81N)
 Malcolm X Library & Performing Arts Center (81O)
 Mira Mesa Branch Library (81P)
 Mission Hills Branch Library (81Q)
 Mission Valley Branch Library (81R)
 North Clairemont Branch Library (81S)
 North Park Branch Library (81T)
 Oak Park Branch Library (81U)
 Ocean Beach Branch Library (81V)
 Otay Mesa-Nestor Branch Library (81W)
 Pacific Beach/Taylor Branch Library (81X)
 Paradise Hills Branch Library (81Y)
 Point Loma/Hervey Branch Library (81Z)
 Rancho Bernardo Branch Library (81AA)
 Rancho Peñasquitos Branch Library (81BB)
 San Carlos Branch Library (81DD)
 San Ysidro Branch Library (81EE)
 Scripps Miramar-Ranch Branch Library (81FF)

Serra Mesa Branch Library (81GG)
 Skyline Hills Branch Library (81HH)
 Tierrasanta Branch Library (81II)
 University Community Branch Library (81JJ)
 University Heights Branch Library (81KK)
 Malcolm A. Love Library (457)

Other Interested Individuals or Groups

Community Planning Groups

Community Planners Committee (194)
 Balboa Park Committee (226 + 226A)
 Black Mountain Ranch –Subarea I (226C)
 Otay Mesa - Nestor Planning Committee (228)
 Otay Mesa Planning Committee (235)
 Clairemont Mesa Planning Committee (248)
 Greater Golden Hill Planning Committee (259)
 Serra Mesa Planning Group (263A)
 Kearny Mesa Community Planning Group (265)
 Linda Vista Community Planning Committee (267)
 La Jolla Community Planning Association (275)
 City Heights Area Planning Committee (287)
 Kensington-Talmadge Planning Committee (290)
 Normal Heights Community Planning Committee (291)
 Eastern Area Planning Committee (302)
 North Bay Community Planning Group (307)
 Mira Mesa Community Planning Group (310)
 Mission Beach Precise Planning Board (325)
 Mission Valley Unified Planning Organization (331)
 Navajo Community Planners Inc. (336)
 Carmel Valley Community Planning Board (350)
 Del Mar Mesa Community Planning Board (361)
 Greater North Park Planning Committee (363)
 Ocean Beach Planning Board (367)
 Old Town Community Planning Committee (368)
 Pacific Beach Community Planning Committee (375)
 Pacific Highlands Ranch – Subarea III (377A)
 Rancho Peñasquitos Planning Board (380)
 Peninsula Community Planning Board (390)
 Rancho Bernardo Community Planning Board (400)
 Sabre Springs Community Planning Group (406B)
 Sabre Springs Community Planning Group (407)
 San Pasqual - Lake Hodges Planning Group (426)
 San Ysidro Planning and Development Group (433)
 Scripps Ranch Community Planning Group (437)
 Miramar Ranch North Planning Committee (439)
 Skyline - Paradise Hills Planning Committee (443)
 Torrey Hills Community Planning Board (444A)
 Southeastern San Diego Planning Committee (449)
 Encanto Neighborhoods Community Planning Group (449A)

College Area Community Council (456)
Tierrasanta Community Council (462)
Torrey Highlands – Subarea IV (467)
Torrey Pines Community Planning Group (469)
University City Community Planning Group (480)
Uptown Planners (498)

Town/Community Councils - PUBLIC NOTICE ONLY

Town Council Presidents Association (197)
Harborview Community Council (246)
Carmel Mountain Ranch Community Council (344)
Clairemont Town Council (257)
Serra Mesa Community Council (264)
Rolando Community Council (288)
Oak Park Community Council (298)
Webster Community Council (301)
Darnell Community Council (306)
La Jolla Town Council (273)
Mission Beach Town Council (326)
Mission Valley Community Council (328 C)
San Carlos Area Council (338)
Ocean Beach Town Council, Inc. (367 A)
Pacific Beach Town Council (374)
Rancho Penasquitos Community Council (378)
Rancho Bernardo Community Council, Inc. (398)
Rancho Penasquitos Town Council (383)
United Border Community Town Council (434)
San Dieguito Planning Group (412)
Murphy Canyon Community Council (463)

Other Interested Individuals or Groups

San Diego Unified Port District (109)
San Diego County Regional Airport Authority (110)
San Diego transit Corporation (112)
San Diego Gas & Electric (114)
Metropolitan Transit Systems (115)
San Diego Unified School District (125/132)
San Ysidro Unified School District (127)
San Diego Community College District (133)
The Beach and Bay Beacon News (137)
Sierra Club (165)
San Diego Canyonlands (165A)
San Diego Natural History Museum (166)
San Diego Audubon Society (167)
Jim Peugh (167A)
California Native Plant Society (170)
San Diego Coastkeeper (173)
Endangered Habitat League (182 and 182A)
South Coastal Information Center @ San Diego State University (210)

San Diego Historical Society (211)
Carmen Lucas (206)
Clint Linton (215b)
San Diego Archaeological Center (212)
Save Our Heritage Organization (214)
Ron Christman (215)
Louie Guassac (215A)
San Diego County Archaeological Society (218)
Kumeyaay Cultural Heritage Preservation (223)
Kumeyaay Cultural Repatriation Committee (225)
Native American Distribution (NOTICE ONLY 225A-T)
San Diego Historical Society (211)
Theresa Acerro (230)
Unified Port of San Diego (240)
Centre City Development Corporation (242)
Centre City Advisory Committee (243)
Balboa Avenue CAC (246)
Theresa Quiros (294)
Fairmount Park Neighborhood Association (303)
John Stump (304)
San Diego Baykeeper (319)
Debbie Knight (320)
Mission Hills Heritage (497)

VII. RESULTS OF PUBLIC REVIEW:

- () No comments were received during the public input period.
- () Comments were received but did not address the draft Mitigated Negative Declaration finding or the accuracy/completeness of the Initial Study. No response is necessary. The letters are attached.
- (x) Comments addressing the findings of the draft Mitigated Negative Declaration and/or accuracy or completeness of the Initial Study were received during the public input period. The letters and responses follow.

Copies of the draft Mitigated Negative Declaration, the Mitigation, Monitoring and Reporting Program and any Initial Study material are available in the office of the Entitlements Division for review, or for purchase at the cost of reproduction.

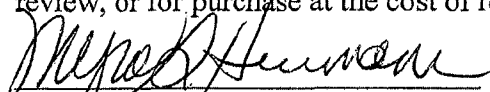
Myra Herrmann, Senior Planner
Development Services Department

September 14, 2011
Date of Draft Report

October 24, 2011
Date of Final Report

Analysts; J. Szymanski/M. Herrmann

Attachments:

Figure 1 - Harbor Drive Pipeline Location Map

Figure 2 - Water Group 949 Site 1 Location Map

Figure 3- Water Group 949 Site 2 Location Map

Figure 4- Water Group 949 Site 3 Location Map

Figure 5- Sewer Group 787 Location Map

Figure 6- Water Group 914 Location Map

Figure 7- Sewer and Water Group 732 Location Map

Figure 8- Water Group 949-Site 2 with the MHPA

Initial Study Checklist

SEWER & AC WATER GROUP JOB 764 AND 821 PROJECT
ADDENDUM TO MITIGATED NEGATIVE DECLARATION NO. 255100
(Project No. 509234)
AND
MITIGATION MONITORING AND REPORTING PROGRAM (MMRP)

ADOPTED ON OCTOBER 13, 2016

WHEREAS, on August 30, 2016, The City of San Diego Public Works Department submitted an application to the Development Services Department of a Public Project Assessment (PPA) for SEWER & AC WATER GROUP JOB 764 AND 821 (Project), for approval of minor technical changes or additions to the Citywide Pipeline Projects scope that was analyzed by adopted Mitigated Negative Declaration No. 255100; and

WHEREAS, the matter was considered without a public hearing by the Deputy Director of the Development Services Department as designated by the City Manager of the City of San Diego on October 13, 2016; and

WHEREAS, on October 13, 2016, the Deputy Director of the Development Services considered the issues discussed in Addendum to Mitigated Negative Declaration No. 255100 (Declaration), a copy of which is on file in the Development Services Department, in accordance with the California Environmental Quality Act of 1970 (CEQA) (Public Resources Code Section 21000 et seq.), as amended, and the State CEQA Guidelines thereto (California Code of Regulations, Title 14, Chapter 3, Section 15000 et seq.); and

WHEREAS, State CEQA Guidelines section 15164(a) allows a lead agency to prepare an Addendum to a final Mitigated Negative Declaration if such Addendum meets the requirements of CEQA; NOW, THEREFORE,

BE IT RESOLVED, by the Deputy Director of the Development Services Department of the City of San Diego as follows:

1. That the information contained in the final Mitigated Negative Declaration No. 255100 along with the Addendum thereto, including any comments received during the public review process, has been reviewed and considered by this Deputy Director of the Development Services Department prior to making a decision on the Project.
2. That there are no substantial changes proposed to the Project and no substantial changes with respect to the circumstances under which the Project is to be undertaken that would require major revisions in the Mitigated Negative Declaration for the Project.
3. That no new information of substantial importance has become available showing that the Project would have any significant effects not discussed previously in Mitigated Negative Declaration or that any significant effects previously examined will be substantially more severe than shown in the Mitigated Negative Declaration.

4. That no new Information of substantial importance has become available showing that mitigation measures or alternatives previously found not to be feasible are in fact feasible which would substantially reduce any significant effects, but that the Project proponents decline to adopt, or that there are any considerably different mitigation measures or alternatives not previously considered which would substantially reduce any significant effects, but that the Project proponents decline to adopt.
5. That pursuant to State CEQA Guidelines Section 15164, only minor technical changes or additions are necessary, and therefore, the Deputy Director of the Development Services Department adopts Addendum to Mitigated Negative Declaration No. 255100 with respect to the Project, a copy of which is on file in the office of the Development Services Department.
6. That pursuant to CEQA Section 21081.6, the Deputy Director of the Development Services Department adopts the Mitigation Monitoring and Reporting Program, or alterations to implement the changes to the project as required by this Deputy Director of the Development Services Department in order to mitigate or avoid significant effects on the environment, which is attached hereto as Exhibit A.
7. That DEVELOPMENT SERVICES STAFF is directed to file a Notice of Determination with the Clerk of the Board of Supervisors for the County of San Diego regarding the Project.

APPROVED: Kerry Santoro, Deputy Director, Development Services Department

By:  _____

Date: 10/13/16

ATTACHMENT: EXHIBIT A – MITIGATION MONITORING AND REPORTING PROGRAM

EXHIBIT A

MITIGATION MONITORING AND REPORTING PROGRAM SEWER & AC WATER GROUP JOB 764 AND 821 PROJECT PROJECT NO. 509234

This Mitigation Monitoring and Reporting Program is designed to ensure compliance with Public Resources Code Section 21081.6 during implementation of mitigation measures. This program identifies at a minimum: the department responsible for the monitoring, what is to be monitored, how the monitoring shall be accomplished, the monitoring and reporting schedule, and completion requirements. A record of the Mitigation Monitoring and Reporting Program will be maintained at the offices of the Entitlements Division, 1222 First Avenue, Fifth Floor, San Diego, CA, 92101.

HISTORICAL RESOURCES (ARCHAEOLOGY)

I. Prior to Permit Issuance or Bid Opening/Bid Award

A. Entitlements Plan Check

1. Prior to permit issuance or Bid Opening/Bid Award, whichever is applicable, the Assistant Deputy Director (ADD) Environmental designee shall verify that the requirements for Archaeological Monitoring and Native American monitoring have been noted on the applicable construction documents through the plan check process.

B. Letters of Qualification have been submitted to ADD

1. Prior to Bid Award, the applicant shall submit a letter of verification to Mitigation Monitoring Coordination (MMC) identifying the Principal Investigator (PI) for the project and the names of all persons involved in the archaeological monitoring program, as defined in the City of San Diego Historical Resources Guidelines (HRG). If applicable, individuals involved in the archaeological monitoring program must have completed the 40-hour HAZWOPER training with certification documentation.
2. MMC will provide a letter to the applicant confirming the qualifications of the PI and all persons involved in the archaeological monitoring of the project meet the qualifications established in the HRG.
3. Prior to the start of work, the applicant must obtain written approval from MMC for any personnel changes associated with the monitoring program.

II. Prior to Start of Construction

A. Verification of Records Search

1. The PI shall provide verification to MMC that a site specific records search (1/4 mile radius) has been completed. Verification includes, but is not limited to a copy of a

confirmation letter from South Coastal Information Center, or, if the search was in-house, a letter of verification from the PI stating that the search was completed.

2. The letter shall introduce any pertinent information concerning expectations and probabilities of discovery during trenching and/or grading activities.
3. The PI may submit a detailed letter to MMC requesting a reduction to the ¼ mile radius.

B. PI Shall Attend Precon Meetings

1. Prior to beginning any work that requires monitoring; the Applicant shall arrange a Precon Meeting that shall include the PI, Native American consultant/monitor (where Native American resources may be impacted), Construction Manager (CM) and/or Grading Contractor, Resident Engineer (RE), Building Inspector (BI), if appropriate, and MMC. The qualified Archaeologist and Native American Monitor shall attend any grading/excavation related Precon Meetings to make comments and/or suggestions concerning the Archaeological Monitoring program with the Construction Manager and/or Grading Contractor.
 - a. If the PI is unable to attend the Precon Meeting, the Applicant shall schedule a focused Precon Meeting with MMC, the PI, RE, CM or BI, if appropriate, prior to the start of any work that requires monitoring.
2. Acknowledgement of Responsibility for Curation (CIP or Other Public Projects)
The applicant shall submit a letter to MMC acknowledging their responsibility for the cost of curation associated with all phases of the archaeological monitoring program.
3. Identify Areas to be Monitored
 - a. Prior to the start of any work that requires monitoring, the PI shall submit an Archaeological Monitoring Exhibit (AME) (with verification that the AME has been reviewed and approved by the Native American consultant/monitor when Native American resources may be impacted) based on the appropriate construction documents (reduced to 11x17) to MMC identifying the areas to be monitored including the delineation of grading/excavation limits.
 - b. The AME shall be based on the results of a site specific records search as well as information regarding the age of existing pipelines, laterals and associated appurtenances and/or any known soil conditions (native or formation).
 - c. MMC shall notify the PI that the AME has been approved.
4. When Monitoring Will Occur

- a. Prior to the start of any work, the PI shall also submit a construction schedule to MMC through the RE indicating when and where monitoring will occur.
 - b. The PI may submit a detailed letter to MMC prior to the start of work or during construction requesting a modification to the monitoring program. This request shall be based on relevant information such as review of final construction documents which indicate conditions such as age of existing pipe to be replaced, depth of excavation and/or site graded to bedrock, etc., which may reduce or increase the potential for resources to be present.
5. Approval of AME and Construction Schedule
After approval of the AME by MMC, the PI shall submit to MMC written authorization of the AME and Construction Schedule from the CM.

III. During Construction

A. Monitor Shall be Present During Grading/Excavation/Trenching

1. The Archaeological Monitor shall be present full-time during all soil disturbing and grading/excavation/trenching activities which could result in impacts to archaeological resources as identified on the AME. **The Construction Manager is responsible for notifying the RE, PI, and MMC of changes to any construction activities such as in the case of a potential safety concern within the area being monitored. In certain circumstances OSHA safety requirements may necessitate modification of the AME.**
2. The Native American consultant/monitor shall determine the extent of their presence during soil disturbing and grading/excavation/trenching activities based on the AME and provide that information to the PI and MMC. If prehistoric resources are encountered during the Native American consultant/monitor's absence, work shall stop and the Discovery Notification Process detailed in Section III.B-C and IV.A-D shall commence.
3. The PI may submit a detailed letter to MMC during construction requesting a modification to the monitoring program when a field condition such as modern disturbance post-dating the previous grading/trenching activities, presence of fossil formations, or when native soils are encountered that may reduce or increase the potential for resources to be present.
4. The archaeological and Native American consultant/monitor shall document field activity via the Consultant Site Visit Record (CSV). The CSV's shall be faxed by the CM to the RE the first day of monitoring, the last day of monitoring, monthly (**Notification of Monitoring Completion**), and in the case of ANY discoveries. The RE shall forward copies to MMC.

B. Discovery Notification Process

1. In the event of a discovery, the Archaeological Monitor shall direct the contractor to temporarily divert all soil disturbing activities, including but not limited to digging, trenching, excavating or grading activities in the area of discovery and in the area reasonably suspected to overlay adjacent resources and immediately notify the RE or BI, as appropriate.
2. The Monitor shall immediately notify the PI (unless Monitor is the PI) of the discovery.
3. The PI shall immediately notify MMC by phone of the discovery, and shall also submit written documentation to MMC within 24 hours by fax or email with photos of the resource in context, if possible.
4. No soil shall be exported off-site until a determination can be made regarding the significance of the resource specifically if Native American resources are encountered.

C. Determination of Significance

1. The PI and Native American consultant/monitor, where Native American resources are discovered shall evaluate the significance of the resource. If Human Remains are involved, follow protocol in Section IV below.
 - a. The PI shall immediately notify MMC by phone to discuss significance determination and shall also submit a letter to MMC indicating whether additional mitigation is required.
 - b. If the resource is significant, the PI shall submit an Archaeological Data Recovery Program (ADRP) and obtain written approval of the program from MMC, CM and RE. ADRP and any mitigation must be approved by MMC, RE and/or CM before ground disturbing activities in the area of discovery will be allowed to resume. **Note: If a unique archaeological site is also an historical resource as defined in CEQA Section 15064.5, then the limits on the amount(s) that a project applicant may be required to pay to cover mitigation costs as indicated in CEQA Section 21083.2 shall not apply.**
 - (1). Note: For pipeline trenching and other linear projects in the public Right-of-Way, the PI shall implement the Discovery Process for Pipeline Trenching projects identified below under "D."
 - c. If the resource is not significant, the PI shall submit a letter to MMC indicating that artifacts will be collected, curated, and documented in the Final Monitoring Report. The letter shall also indicate that that no further work is required.

- (1). Note: For Pipeline Trenching and other linear projects in the public Right-of-Way, if the deposit is limited in size, both in length and depth; the information value is limited and is not associated with any other resource; and there are no unique features/artifacts associated with the deposit, the discovery should be considered not significant.
- (2). Note, for Pipeline Trenching and other linear projects in the public Right-of-Way, if significance cannot be determined, the Final Monitoring Report and Site Record (DPR Form 523A/B) shall identify the discovery as Potentially Significant.

D. Discovery Process for Significant Resources - Pipeline Trenching and other Linear Projects in the Public Right-of-Way

The following procedure constitutes adequate mitigation of a significant discovery encountered during pipeline trenching activities or for other linear project types within the Public Right-of-Way including but not limited to excavation for jacking pits, receiving pits, laterals, and manholes to reduce impacts to below a level of significance:

1. Procedures for documentation, curation and reporting
 - a. One hundred percent of the artifacts within the trench alignment and width shall be documented in-situ, to include photographic records, plan view of the trench and profiles of side walls, recovered, photographed after cleaning and analyzed and curated. The remainder of the deposit within the limits of excavation (trench walls) shall be left intact.
 - b. The PI shall prepare a Draft Monitoring Report and submit to MMC via the RE as indicated in Section VI-A.
 - c. The PI shall be responsible for recording (on the appropriate State of California Department of Park and Recreation forms-DPR 523 A/B) the resource(s) encountered during the Archaeological Monitoring Program in accordance with the City's Historical Resources Guidelines. The DPR forms shall be submitted to the South Coastal Information Center for either a Primary Record or SDI Number and included in the Final Monitoring Report.
 - d. The Final Monitoring Report shall include a recommendation for monitoring of any future work in the vicinity of the resource.

IV. Discovery of Human Remains

If human remains are discovered, work shall halt in that area and no soil shall be exported off-site until a determination can be made regarding the provenance of the human remains; and the following procedures as set forth in CEQA Section 15064.5(e), the California Public

Resources Code (Sec. 5097.98) and State Health and Safety Code (Sec. 7050.5) shall be undertaken:

A. Notification

1. Archaeological Monitor shall notify the RE or BI as appropriate, MMC, and the PI, if the Monitor is not qualified as a PI. MMC will notify the appropriate Senior Planner in the Environmental Analysis Section (EAS) of the Development Services Department to assist with the discovery notification process.
2. The PI shall notify the Medical Examiner after consultation with the RE, either in person or via telephone.

B. Isolate discovery site

1. Work shall be directed away from the location of the discovery and any nearby area reasonably suspected to overlay adjacent human remains until a determination can be made by the Medical Examiner in consultation with the PI concerning the provenience of the remains.
2. The Medical Examiner, in consultation with the PI, will determine the need for a field examination to determine the provenience.
3. If a field examination is not warranted, the Medical Examiner will determine with input from the PI, if the remains are or are most likely to be of Native American origin.

C. If Human Remains **ARE** determined to be Native American

1. The Medical Examiner will notify the Native American Heritage Commission (NAHC) within 24 hours. By law, **ONLY** the Medical Examiner can make this call.
2. NAHC will immediately identify the person or persons determined to be the Most Likely Descendent (MLD) and provide contact information.
3. The MLD will contact the PI within 24 hours or sooner after the Medical Examiner has completed coordination, to begin the consultation process in accordance with CEQA Section 15064.5(e), the California Public Resources and Health & Safety Codes.
4. The MLD will have 48 hours to make recommendations to the property owner or representative, for the treatment or disposition with proper dignity, of the human remains and associated grave goods.
5. Disposition of Native American Human Remains will be determined between the MLD and the PI, and, if:

- a. The NAHC is unable to identify the MLD, OR the MLD failed to make a recommendation within 48 hours after being notified by the Commission, OR;
- b. The landowner or authorized representative rejects the recommendation of the MLD and mediation in accordance with PRC 5097.94 (k) by the NAHC fails to provide measures acceptable to the landowner, THEN
- c. To protect these sites, the landowner shall do one or more of the following:
 - (1) Record the site with the NAHC;
 - (2) Record an open space or conservation easement; or
 - (3) Record a document with the County.
- d. Upon the discovery of multiple Native American human remains during a ground disturbing land development activity, the landowner may agree that additional conferral with descendants is necessary to consider culturally appropriate treatment of multiple Native American human remains. Culturally appropriate treatment of such a discovery may be ascertained from review of the site utilizing cultural and archaeological standards. Where the parties are unable to agree on the appropriate treatment measures the human remains and items associated and buried with Native American human remains shall be reinterred with appropriate dignity, pursuant to Section 5.c., above.

D. If Human Remains are **NOT** Native American

- 1. The PI shall contact the Medical Examiner and notify them of the historic era context of the burial.
- 2. The Medical Examiner will determine the appropriate course of action with the PI and City staff (PRC 5097.98).
- 3. If the remains are of historic origin, they shall be appropriately removed and conveyed to the San Diego Museum of Man for analysis. The decision for internment of the human remains shall be made in consultation with MMC, EAS, the applicant/landowner, any known descendant group, and the San Diego Museum of Man.

V. Night and/or Weekend Work

A. If night and/or weekend work is included in the contract

- 1. When night and/or weekend work is included in the contract package, the extent and timing shall be presented and discussed at the precon meeting.

2. The following procedures shall be followed.

a. No Discoveries

In the event that no discoveries were encountered during night and/or weekend work, the PI shall record the information on the CSVR and submit to MMC via fax by 8AM of the next business day.

b. Discoveries

All discoveries shall be processed and documented using the existing procedures detailed in Sections III - During Construction, and IV - Discovery of Human Remains. Discovery of human remains shall always be treated as a significant discovery.

c. Potentially Significant Discoveries

If the PI determines that a potentially significant discovery has been made, the procedures detailed under Section III - During Construction and IV-Discovery of Human Remains shall be followed.

d. The PI shall immediately contact the RE and MMC, or by 8AM of the next business day to report and discuss the findings as indicated in Section III-B, unless other specific arrangements have been made.

B. If night and/or weekend work becomes necessary during the course of construction

1. The Construction Manager shall notify the RE, or BI, as appropriate, a minimum of 24 hours before the work is to begin.

2. The RE, or BI, as appropriate, shall notify MMC immediately.

C. All other procedures described above shall apply, as appropriate.

VI. Post Construction

A. Submittal of Draft Monitoring Report

1. The PI shall submit two copies of the Draft Monitoring Report (even if negative), prepared in accordance with the Historical Resources Guidelines (Appendix C/D) which describes the results, analysis, and conclusions of all phases of the Archaeological Monitoring Program (with appropriate graphics) to MMC via the RE for review and approval within 90 days following the completion of monitoring. **It should be noted that if the PI is unable to submit the Draft Monitoring Report within the allotted 90-day timeframe as a result of delays with analysis, special study results or other complex issues, a schedule shall be submitted to MMC**

establishing agreed due dates and the provision for submittal of monthly status reports until this measure can be met.

- a. For significant archaeological resources encountered during monitoring, the Archaeological Data Recovery Program or Pipeline Trenching Discovery Process shall be included in the Draft Monitoring Report.
 - b. Recording Sites with State of California Department of Parks and Recreation
The PI shall be responsible for recording (on the appropriate State of California Department of Park and Recreation forms-DPR 523 A/B) any significant or potentially significant resources encountered during the Archaeological Monitoring Program in accordance with the City's Historical Resources Guidelines, and submittal of such forms to the South Coastal Information Center with the Final Monitoring Report.
2. MMC shall return the Draft Monitoring Report to the PI via the RE for revision or, for preparation of the Final Report.
 3. The PI shall submit revised Draft Monitoring Report to MMC via the RE for approval.
 4. MMC shall provide written verification to the PI of the approved report.
 5. MMC shall notify the RE or BI, as appropriate, of receipt of all Draft Monitoring Report submittals and approvals.
- B. Handling of Artifacts
1. The PI shall be responsible for ensuring that all cultural remains collected are cleaned and catalogued.
 2. The PI shall be responsible for ensuring that all artifacts are analyzed to identify function and chronology as they relate to the history of the area; that faunal material is identified as to species; and that specialty studies are completed, as appropriate.
- C. Curation of artifacts: Accession Agreement and Acceptance Verification
1. The PI shall be responsible for ensuring that all artifacts associated with the survey, testing and/or data recovery for this project are permanently curated with an appropriate institution. This shall be completed in consultation with MMC and the Native American representative, as applicable.
 2. When applicable to the situation, the PI shall include written verification from the Native American consultant/monitor indicating that Native American resources were treated in accordance with state law and/or applicable agreements. If the resources were reinterred, verification shall be provided to show what protective measures

were taken to ensure no further disturbance occurs in accordance with Section IV – Discovery of Human Remains, Subsection C.

3. The PI shall submit the Accession Agreement and catalogue record(s) to the RE or BI, as appropriate for donor signature with a copy submitted to MMC.
 4. The RE or BI, as appropriate shall obtain signature on the Accession Agreement and shall return to PI with copy submitted to MMC.
 5. The PI shall include the Acceptance Verification from the curation institution in the Final Monitoring Report submitted to the RE or BI and MMC.
- D. Final Monitoring Report(s)
1. The PI shall submit one copy of the approved Final Monitoring Report to the RE or BI as appropriate, and one copy to MMC (even if negative), within 90 days after notification from MMC of the approved report.
 2. The RE shall, in no case, issue the Notice of Completion until receiving a copy of the approved Final Monitoring Report from MMC which includes the Acceptance Verification from the curation institution.

PALEONTOLOGICAL RESOURCES

I. Prior to Permit Issuance or Bid Opening/Bid Award

A. Entitlements Plan Check

1. Prior to permit issuance or Bid Opening/Bid Award, whichever is applicable, the Assistant Deputy Director (ADD) Environmental designee shall verify that the requirements for Paleontological Monitoring have been noted on the appropriate construction documents.

B. Letters of Qualification have been submitted to ADD

1. Prior to Bid Award, the applicant shall submit a letter of verification to Mitigation Monitoring Coordination (MMC) identifying the Principal Investigator (PI) for the project and the names of all persons involved in the paleontological monitoring program, as defined in the City of San Diego Paleontology Guidelines.
2. MMC will provide a letter to the applicant confirming the qualifications of the PI and all persons involved in the paleontological monitoring of the project.
3. Prior to the start of work, the applicant shall obtain approval from MMC for any personnel changes associated with the monitoring program.

II. Prior to Start of Construction

A. Verification of Records Search

1. The PI shall provide verification to MMC that a site specific records search has been completed. Verification includes, but is not limited to a copy of a confirmation letter from San Diego Natural History Museum, other institution or, if the search was in-house, a letter of verification from the PI stating that the search was completed.

2. The letter shall introduce any pertinent information concerning expectations and probabilities of discovery during trenching and/or grading activities.
- B. PI Shall Attend Precon Meetings
1. Prior to beginning any work that requires monitoring, the Applicant shall arrange a Precon Meeting that shall include the PI, Construction Manager (CM) and/or Grading Contractor, Resident Engineer (RE), Building Inspector (BI), if appropriate, and MMC. The qualified paleontologist shall attend any grading/excavation related Precon Meetings to make comments and/or suggestions concerning the Paleontological Monitoring program with the Construction Manager and/or Grading Contractor.
 - a. If the PI is unable to attend the Precon Meeting, the Applicant shall schedule a focused Precon Meeting with MMC, the PI, RE, CM or BI, if appropriate, prior to the start of any work that requires monitoring.
 2. Acknowledgement of Responsibility for Curation (CIP or Other Public Projects)
The applicant shall submit a letter to MMC acknowledging their responsibility for the cost of curation associated with all phases of the paleontological monitoring program.
 3. Identify Areas to be Monitored
 - a. Prior to the start of any work that requires monitoring, the PI shall submit a Paleontological Monitoring Exhibit (PME) based on the appropriate construction documents (reduced to 11x17) to MMC for approval identifying the areas to be monitored including the delineation of grading/excavation limits. Monitoring shall begin at depths below 10 feet from existing grade or as determined by the PI in consultation with MMC. The determination shall be based on site specific records search data which supports monitoring at depths less than ten feet.
 - b. The PME shall be based on the results of a site specific records search as well as information regarding existing known soil conditions (native or formation).
 - c. MMC shall notify the PI that the PME has been approved.
 4. When Monitoring Will Occur
 - a. Prior to the start of any work, the PI shall also submit a construction schedule to MMC through the RE indicating when and where monitoring will occur.
 - b. The PI may submit a detailed letter to MMC prior to the start of work or during construction requesting a modification to the monitoring program. This request shall be based on relevant information such as review of final construction documents which indicate conditions such as depth of excavation and/or site graded to bedrock, presence or absence of fossil resources, etc., which may reduce or increase the potential for resources to be present.
 5. Approval of PME and Construction Schedule
After approval of the PME by MMC, the PI shall submit to MMC written authorization of the PME and Construction Schedule from the CM.

III. During Construction

- A. Monitor Shall be Present During Grading/Excavation/Trenching
1. The monitor shall be present full-time during grading/excavation/trenching activities including, but not limited to mainline, laterals, jacking and receiving pits, services and all other appurtenances associated with underground utilities as identified on the

PME that could result in impacts to formations with high and/or moderate resource sensitivity. **The Construction Manager is responsible for notifying the RE, PI, and MMC of changes to any construction activities such as in the case of a potential safety concern within the area being monitored. In certain circumstances OSHA safety requirements may necessitate modification of the PME.**

2. The PI may submit a detailed letter to MMC during construction requesting a modification to the monitoring program when a field condition such as trenching activities that do not encounter formational soils as previously assumed, and/or when unique/unusual fossils are encountered, which may reduce or increase the potential for resources to be present.
 3. The monitor shall document field activity via the Consultant Site Visit Record (CSV). The CSV's shall be faxed by the CM to the RE the first day of monitoring, the last day of monitoring, monthly (Notification of Monitoring Completion), and in the case of ANY discoveries. The RE shall forward copies to MMC.
- B. Discovery Notification Process
1. In the event of a discovery, the Paleontological Monitor shall direct the contractor to temporarily divert trenching activities in the area of discovery and immediately notify the RE or BI, as appropriate.
 2. The Monitor shall immediately notify the PI (unless Monitor is the PI) of the discovery.
 3. The PI shall immediately notify MMC by phone of the discovery, and shall also submit written documentation to MMC within 24 hours by fax or email with photos of the resource in context, if possible.
- C. Determination of Significance
1. The PI shall evaluate the significance of the resource.
 - a. The PI shall immediately notify MMC by phone to discuss significance determination and shall also submit a letter to MMC indicating whether additional mitigation is required. The determination of significance for fossil discoveries shall be at the discretion of the PI.
 - b. If the resource is significant, the PI shall submit a Paleontological Recovery Program (PRP) and obtain written approval of the program from MMC, MC and/or RE. PRP and any mitigation must be approved by MMC, RE and/or CM before ground disturbing activities in the area of discovery will be allowed to resume.
 - (1). Note: For pipeline trenching projects only, the PI shall implement the Discovery Process for Pipeline Trenching projects identified below under "D."
 - c. If resource is not significant (e.g., small pieces of broken common shell fragments or other scattered common fossils) the PI shall notify the RE, or BI as appropriate, that a non-significant discovery has been made. The Paleontologist shall continue to monitor the area without notification to MMC unless a significant resource is encountered.
 - d. The PI shall submit a letter to MMC indicating that fossil resources will be collected, curated, and documented in the Final Monitoring Report. The letter shall also indicate that no further work is required.

- (1). Note: For Pipeline Trenching Projects Only. If the fossil discovery is limited in size, both in length and depth; the information value is limited and there are no unique fossil features associated with the discovery area, then the discovery should be considered not significant.
- (2). Note, for Pipeline Trenching Projects Only: If significance can not be determined, the Final Monitoring Report and Site Record shall identify the discovery as Potentially Significant.

D. Discovery Process for Significant Resources - Pipeline Trenching Projects

The following procedure constitutes adequate mitigation of a significant discovery encountered during pipeline trenching activities including but not limited to excavation for jacking pits, receiving pits, laterals, and manholes to reduce impacts to below a level of significance.

1. Procedures for documentation, curation and reporting
 - a. One hundred percent of the fossil resources within the trench alignment and width shall be documented in-situ photographically, drawn in plan view (trench and profiles of side walls), recovered from the trench and photographed after cleaning, then analyzed and curated consistent with Society of Invertebrate Paleontology Standards. The remainder of the deposit within the limits of excavation (trench walls) shall be left intact and so documented.
 - b. The PI shall prepare a Draft Monitoring Report and submit to MMC via the RE as indicated in Section VI-A.
 - c. The PI shall be responsible for recording (on the appropriate forms for the San Diego Natural History Museum) the resource(s) encountered during the Paleontological Monitoring Program in accordance with the City's Paleontological Guidelines. The forms shall be submitted to the San Diego Natural History Museum and included in the Final Monitoring Report.
 - d. The Final Monitoring Report shall include a recommendation for monitoring of any future work in the vicinity of the resource.

IV. Night and/or Weekend Work

- A. If night and/or weekend work is included in the contract
 1. When night and/or weekend work is included in the contract package, the extent and timing shall be presented and discussed at the precon meeting.
 2. The following procedures shall be followed.
 - a. No Discoveries
In the event that no discoveries were encountered during night and/or weekend work, The PI shall record the information on the CSV and submit to MMC via the RE via fax by 8AM on the next business day.
 - b. Discoveries
All discoveries shall be processed and documented using the existing procedures detailed in Sections III - During Construction.
 - c. Potentially Significant Discoveries
If the PI determines that a potentially significant discovery has been made, the procedures detailed under Section III - During Construction shall be followed.

- d. The PI shall immediately contact the RE and MMC, or by 8AM on the next business day to report and discuss the findings as indicated in Section III-B, unless other specific arrangements have been made.
- B. If night and/or weekend work becomes necessary during the course of construction
 - 1. The Construction Manager shall notify the RE, or BI, as appropriate, a minimum of 24 hours before the work is to begin.
 - 2. The RE, or BI, as appropriate, shall notify MMC immediately.
- C. All other procedures described above shall apply, as appropriate.

V. Post Construction

- A. Preparation and Submittal of Draft Monitoring Report
 - 1. The PI shall submit two copies of the Draft Monitoring Report (even if negative), prepared in accordance with the Paleontological Guidelines which describes the results, analysis, and conclusions of all phases of the Paleontological Monitoring Program (with appropriate graphics) to MMC via the RE for review and approval within 90 days following the completion of monitoring,
 - a. For significant paleontological resources encountered during monitoring, the Paleontological Recovery Program or Pipeline Trenching Discovery Process shall be included in the Draft Monitoring Report.
 - b. Recording Sites with the San Diego Natural History Museum
The PI shall be responsible for recording (on the appropriate forms) any significant or potentially significant fossil resources encountered during the Paleontological Monitoring Program in accordance with the City's Paleontological Guidelines, and submittal of such forms to the San Diego Natural History Museum with the Final Monitoring Report.
 - 2. MMC shall return the Draft Monitoring Report to the PI via the RE for revision or, for preparation of the Final Report.
 - 3. The PI shall submit revised Draft Monitoring Report to MMC via the RE for approval.
 - 4. MMC shall provide written verification to the PI of the approved report.
 - 5. MMC shall notify the RE or BI, as appropriate, of receipt of all Draft Monitoring Report submittals and approvals.
- B. Handling of Fossil Remains
 - 1. The PI shall be responsible for ensuring that all fossil remains collected are cleaned and catalogued.
- C. Curation of artifacts: Deed of Gift and Acceptance Verification
 - 1. The PI shall be responsible for ensuring that all fossil remains associated with the monitoring for this project are permanently curated with an appropriate institution.
 - 2. The PI shall submit the Deed of Gift and catalogue record(s) to the RE or BI, as appropriate for donor signature with a copy submitted to MMC.
 - 3. The RE or BI, as appropriate shall obtain signature on the Deed of Gift and shall return to PI with copy submitted to MMC.
 - 4. The PI shall include the Acceptance Verification from the curation institution in the Final Monitoring Report submitted to the RE or BI and MMC.
- D. Final Monitoring Report(s)
 - 1. The PI shall submit two copies of the Final Monitoring Report to MMC (even if negative), within 90 days after notification from MMC of the approved report.

2. The RE shall, in no case, issue the Notice of Completion until receiving a copy of the approved Final Monitoring Report from MMC which includes the Acceptance Verification from the curation institution.

The above Mitigation Monitoring and Reporting Program will require additional fees and/or deposits to be collected prior to the issuance of building permits, certificates or occupancy and/or final maps to ensure the successful completion of the monitoring program.

NOTICE OF DETERMINATION (SUBSEQUENT ACTION)

TO: X Recorder/County Clerk
P.O. Box 1750, MS A33
1600 Pacific Hwy, Room 260
San Diego, CA 92101-2422

FROM: City of San Diego
Development Services Department
1222 First Avenue, MS 501
San Diego, CA 92101

____ Office of Planning and Research
1400 Tenth Street, Room 121
Sacramento, CA 95814

PROJECT NUMBER: 509234/WBS No. B-15106.02.06 & -15107.02.06 **STATE CLEARINGHOUSE NUMBER:** 2011091045

PROJECT TITLE: Sewer and AC Water Group 764 and 821 Project

DESCRIPTION OF PREVIOUS ACTION: The City of San Diego previously prepared a Mitigated Negative Declaration for the Citywide Pipelines project (Project No. 255100). The Mitigated Negative Declaration was certified by the City of San Diego City Council on November 30, 2011, Resolution No. 30712.

DESCRIPTION OF SUBSEQUENT ACTION: City of San Diego Development Services Department approval of Addendum to Mitigated Negative Declaration No. 255100 in association with a Public Project Assessment for the Sewer and AC Water Group 764 and 821 project.

PROJECT LOCATION: The project is located in the Peninsula Community Plan area within Council District 1. The project will occur within the existing improved public rights-of-way between and adjacent to previously disturbed land within City utility easements on private property. Specific areas include:

SEWER & AC WATER GROUP JOB 764

Fenelon St. (East and West of the Intersection of Carleton St., Fenelon St. (West of Clove St.), Clove St. (South of intersection with Fenelon St. to intersection with Emerson St.), Clove St. (South of intersection with Fenelon St. to intersection with Emerson St.), Alleyway (Between Clove St. and Plum St.), Ave. de Portugal (Small segment west of Plum St.), Moana Dr. (Between Lomaland Dr. and John St.), Moana Dr. (Between Lomaland Dr. and John St.), Silver Gate Ave. (Border with naval base to before Pio Pico St.), Silver Gate Ave. (Border with naval base to Silver Gate Pl.), Silver Gate Pl. (From intersection with Silver Gate Ave. midway through block), Silver Gate Pl. (From intersection with Silver Gate Ave. – entire block), Cedarbrae Lane (Between intersection with Catalina Blvd. to intersection with Silver Gate Ave.), Cedarbrae Lane (Between intersection with Catalina Blvd. to intersection with Silver Gate Ave.), Trudy Lane (From end of cul-de-sac to Cedarbrae Lane), San Gorgonio St. (South of intersection with Kellogg St.), Kellogg St. (From intersection with San Gorgonio St. to San Elijo St.), Kellogg St. (From intersection with San Gorgonio St. to San Elijo St.), San Fernando St. (South of intersection with Kellogg St. to naval base border), San Fernando St. (South of intersection with Kellogg St. to naval base border), San Elijo St. (South of intersection with Kellogg St. to naval base border).

SEWER & AC WATER GROUP JOB 821

Dudley St. (From intersection with Catalina Blvd. to intersection with Silver Gate Ave.), Warner St. (From intersection with Catalina Blvd. to intersection with Silver Gate Ave.), Dupont St. (From intersection with Catalina Blvd. to intersection with Silver Gate Ave.), Dupont St. (From intersection with Albion St. to intersection with Gage Ave.), Dupont St. (From intersection with Silver Gate Ave. to intersection with Gage Ave.), Gage Dive (From southern end of roadway to intersection with Jennings St.), Gage Dive (From southern end of roadway to intersection with Jennings St.), Gage Pl. (Entire Street), Three Unnamed Alleyways (West of Silver Gate Ave., between Pio Pico St. and Dudley St.), Two Unnamed Alleyways (West of Silver Gate Ave., between Charles St. and Jennings St.), Wilcox St. (West of intersection with Silver Gate Ave. to terminus of St.), Albion St. (North of intersection with Jennings St. to Talbot St.), Albion St. (North of intersection with Dupont St. to Charles St.), Unnamed Alleyway (From intersection with Charles St. to intersection with Jennings St.

PROJECT DESCRIPTION: Sewer and AC Water Group 764 and 821 is a part of the City of San Diego's on-going Sewer Main and Water Main Replacement Program. The existing sewer and water lines are old and are nearing the end of their service life. Construction of the project will reduce maintenance requirements, correct hydraulic deficiencies, improve reliability and

accessibility, and bring the sewer and water main systems up to current design standards. The purpose of the Sewer and AC Water Group 764 and 821 Project is to improve the existing water and sewer systems.

This will be accomplished by replacing 9,817 linear feet (LF) of existing 8 inch water main lines with new 8 inch water main lines within existing alignments at depths of 3-5 feet below existing grade. It should be noted portions of this line will be deeper than existing trenching depth. Additionally, 3,625 linear feet (LF) of 8 inch water main lines are proposed to be installed within new alignments of depths ranging from 3-5 feet.

The project would also "replace-in-place" approximately 9,817 linear feet (LF) of existing 8 inch cast-iron (CI) water pipes with new 8 inch polyvinyl chloride (PVC) piping. This will be placed within existing alignments at current grade levels or deeper. It should be noted that 3,625 linear feet (LF) will be placed within new alignments at depths ranging from 3-5 feet below grade.

The project would also replace 5,934 linear feet (LF) of existing 8 inch vitrified clay (VC) sewer main lines with new 8 inch polyvinyl chloride (PVC) piping within existing alignments at depths of 3-5 feet below existing grade. It should be noted portions of this line will be deeper than existing trenching depth. Additionally, 6,531 linear feet (LF) of 8 inch polyvinyl chloride (PVC) sewer main lines are proposed to be installed within new alignments of depths ranging from 4-22.5 feet. Furthermore, 2,730 linear feet (LF) of existing sewer pipe will be rehabilitated via tunneling methodology.

The project would also include the abandonment of 364 linear feet (LF) of existing sewer main lines. Inclusive of this portion of the project, existing manholes and areas with exposed pipes will be removed.

Pipeline abandonment activities will have minimum surface/subsurface disturbance. The lines would be left in place, capped at both ends and slurry filled per engineering design standards. All abandonments would occur within existing public right of way/roadways.

Other components of the project will include the installation of curb ramps, laterals, cleanouts, water meters, water boxes, slurry seal, provide pavement overlay, rehabilitate existing manholes and provide St. resurfacing where applicable. All work will occur either within previously disturbed areas or areas below grade. As such, there would be no impacts to sensitive biological resources. The Sewer and AC Water Group 764 and 821 project is part of the City of San Diego's ongoing Sewer Main and Water Main Replacement Program (Citywide Pipelines Project MND No. 255100).

PROJECT APPLICANT: Roberto Vejar-Parra, Project Manager, City of San Diego Public Works Department - Engineering, 525 B Street, Suite 750, San Diego, CA 92101. Contact: (619) 533-5402.

This is to advise that the City of San Diego Development Services Department on October 13, 2016 approved the above described project and made the following determinations:

1. The project in its approved form ___ will, X will not, have a significant effect on the environment.
2. ___ An Environmental Impact Report was prepared for this project and certified pursuant to the provisions of CEQA.
___ A (Mitigated) Negative Declaration was prepared for this project pursuant to the provisions of CEQA.
X An Addendum to Mitigated Negative Declaration 255100 was prepared for this project pursuant to the provisions of CEQA.

Record of project approval may be examined at the address above.

3. Mitigation measures X were, ___ were not, made a condition of the approval of the project; and a mitigation monitoring and reporting program X was, ___ was not, adopted for the project.
4. (EIR only) Findings ___ were, ___ were not, made pursuant to CEQA Guidelines Section 15091.
5. (EIR only) A Statement of Overriding Considerations ___ was, ___ was not, adopted for this project.

It is hereby certified that the final environmental report, including comments and responses, is available to the general public at the office of the Development Services Department, 1222 First Avenue, San Diego, CA 92101.

Analyst: Mark Brunette

Telephone: (619) 446-5379

Filed by: _____

Signature

Senior Planner

Title

[Attach Copy of Check, Proof of CDFG Payment, "de Minimis" Certificate, or No Effect Form]

Reference: California Public Resources Code, Sections 21108 and 21152.

APPENDIX B
FIRE HYDRANT METER PROGRAM

CITY OF SAN DIEGO CALIFORNIA DEPARTMENT INSTRUCTIONS	NUMBER DI 55.27	DEPARTMENT Water Department
SUBJECT FIRE HYDRANT METER PROGRAM (FORMERLY: CONSTRUCTION METER PROGRAM)	PAGE 1 OF 10	EFFECTIVE DATE October 15, 2002
	SUPERSEDES DI 55.27	DATED April 21, 2000

1. **PURPOSE**

- 1.1 To establish a Departmental policy and procedure for issuance, proper usage and charges for fire hydrant meters.

2. **AUTHORITY**

- 2.1 All authorities and references shall be current versions and revisions.
- 2.2 San Diego Municipal Code (NC) Chapter VI, Article 7, Sections 67.14 and 67.15
- 2.3 Code of Federal Regulations, Safe Drinking Water Act of 1986
- 2.4 California Code of Regulations, Titles 17 and 22
- 2.5 California State Penal Code, Section 498B.0
- 2.6 State of California Water Code, Section 110, 500-6, and 520-23
- 2.7 Water Department Director

Reference

- 2.8 State of California Guidance Manual for Cross Connection Programs
- 2.9 American Water Works Association Manual M-14, Recommended Practice for Backflow Prevention
- 2.10 American Water Works Association Standards for Water Meters
- 2.11 U.S.C. Foundation for Cross Connection Control and Hydraulic Research Manual

3. **DEFINITIONS**

- 3.1 **Fire Hydrant Meter:** A portable water meter which is connected to a fire hydrant for the purpose of temporary use. (These meters are sometimes referred to as Construction Meters.)

CITY OF SAN DIEGO CALIFORNIA DEPARTMENT INSTRUCTIONS	NUMBER DI 55.27	DEPARTMENT Water Department
SUBJECT FIRE HYDRANT METER PROGRAM (FORMERLY: CONSTRUCTION METER PROGRAM)	PAGE 2 OF 10	EFFECTIVE DATE October 15, 2002
	SUPERSEDES DI 55.27	DATED April 21, 2000

3.2 **Temporary Water Use:** Water provided to the customer for no longer than twelve (12) months.

3.3 **Backflow Preventor:** A Reduced Pressure Principle Assembly connected to the outlet side of a Fire Hydrant Meter.

4. **POLICY**

4.1 The Water Department shall collect a deposit from every customer requiring a fire hydrant meter and appurtenances prior to providing the meter and appurtenances (see Section 7.1 regarding the Fees and Deposit Schedule). The deposit is refundable upon the termination of use and return of equipment and appurtenances in good working condition.

4.2 Fire hydrant meters will have a 2 ½" swivel connection between the meter and fire hydrant. The meter shall not be connected to the 4" port on the hydrant. All Fire Hydrant Meters issued shall have a Reduced Pressure Principle Assembly (RP) as part of the installation. Spanner wrenches are the only tool allowed to turn on water at the fire hydrant.

4.3 The use of private hydrant meters on City hydrants is prohibited, with exceptions as noted below. All private fire hydrant meters are to be phased out of the City of San Diego. All customers who wish to continue to use their own fire hydrant meters must adhere to the following conditions:

a. Meters shall meet all City specifications and American Water Works Association (AWWA) standards.

b. Customers currently using private fire hydrant meters in the City of San Diego water system will be allowed to continue using the meter under the following conditions:

1. The customer must submit a current certificate of accuracy and calibration results for private meters and private backflows annually to the City of San Diego, Water Department, Meter Shop.

CITY OF SAN DIEGO CALIFORNIA DEPARTMENT INSTRUCTIONS	NUMBER DI 55.27	DEPARTMENT Water Department
SUBJECT FIRE HYDRANT METER PROGRAM (FORMERLY: CONSTRUCTION METER PROGRAM)	PAGE 3 OF 10	EFFECTIVE DATE October 15, 2002
	SUPERSEDES DI 55.27	DATED April 21, 2000

2. The meter must be properly identifiable with a clearly labeled serial number on the body of the fire hydrant meter. The serial number shall be plainly stamped on the register lid and the main casing. Serial numbers shall be visible from the top of the meter casing and the numbers shall be stamped on the top of the inlet casing flange.
3. All meters shall be locked to the fire hydrant by the Water Department, Meter Section (see Section 4.7).
4. All meters shall be read by the Water Department, Meter Section (see Section 4.7).
5. All meters shall be relocated by the Water Department, Meter Section (see Section 4.7).
6. These meters shall be tested on the anniversary of the original test date and proof of testing will be submitted to the Water Department, Meter Shop, on a yearly basis. If not tested, the meter will not be allowed for use in the City of San Diego.
7. All private fire hydrant meters shall have backflow devices attached when installed.
8. The customer must maintain and repair their own private meters and private backflows.
9. The customer must provide current test and calibration results to the Water Department, Meter Shop after any repairs.
10. When private meters are damaged beyond repair, these private meters will be replaced by City owned fire hydrant meters.

CITY OF SAN DIEGO CALIFORNIA DEPARTMENT INSTRUCTIONS	NUMBER DI 55.27	DEPARTMENT Water Department
SUBJECT FIRE HYDRANT METER PROGRAM (FORMERLY: CONSTRUCTION METER PROGRAM)	PAGE 4 OF 10	EFFECTIVE DATE October 15, 2002
	SUPERSEDES DI 55.27	DATED April 21, 2000

11. When a private meter malfunctions, the customer will be notified and the meter will be removed by the City and returned to the customer for repairs. Testing and calibration results shall be given to the City prior to any re-installation.
 12. The register shall be hermetically sealed straight reading and shall be readable from the inlet side. Registration shall be in hundred cubic feet.
 13. The outlet shall have a 2 ½ "National Standards Tested (NST) fire hydrant male coupling.
 14. Private fire hydrant meters shall not be transferable from one contracting company to another (i.e. if a company goes out of business or is bought out by another company).
- 4.4 All fire hydrant meters and appurtenances shall be installed, relocated and removed by the City of San Diego, Water Department. All City owned fire hydrant meters and appurtenances shall be maintained by the City of San Diego, Water Department, Meter Services.
- 4.5 If any fire hydrant meter is used in violation of this Department Instruction, the violation will be reported to the Code Compliance Section for investigation and appropriate action. Any customer using a fire hydrant meter in violation of the requirements set forth above is subject to fines or penalties pursuant to the Municipal Code, Section 67.15 and Section 67.37.
- 4.6 **Conditions and Processes for Issuance of a Fire Hydrant Meter**

Process for Issuance

- a. Fire hydrant meters shall only be used for the following purposes:
 1. Temporary irrigation purposes not to exceed one year.

CITY OF SAN DIEGO CALIFORNIA DEPARTMENT INSTRUCTIONS	NUMBER DI 55.27	DEPARTMENT Water Department
SUBJECT FIRE HYDRANT METER PROGRAM (FORMERLY: CONSTRUCTION METER PROGRAM)	PAGE 5 OF 10	EFFECTIVE DATE October 15, 2002
	SUPERSEDES DI 55.27	DATED April 21, 2000

2. Construction and maintenance related activities (see Tab 2).
 - b. No customer inside or outside the boundaries of the City of San Diego Water Department shall resell any portion of the water delivered through a fire hydrant by the City of San Diego Water Department.
 - c. The City of San Diego allows for the issuance of a temporary fire hydrant meter for a period not to exceed 12 months (365 days). An extension can only be granted in writing from the Water Department Director for up to 90 additional days. A written request for an extension by the consumer must be submitted at least 30 days prior to the 12 month period ending. No extension shall be granted to any customer with a delinquent account with the Water Department. No further extensions shall be granted.
 - d. Any customer requesting the issuance of a fire hydrant meter shall file an application with the Meter Section. The customer must complete a "Fire Hydrant Meter Application" (Tab 1) which includes the name of the company, the party responsible for payment, Social Security number and/or California ID, requested location of the meter (a detailed map signifying an exact location), local contact person, local phone number, a contractor's license (or a business license), description of specific water use, duration of use at the site and full name and address of the person responsible for payment.
 - e. At the time of the application the customer will pay their fees according to the schedule set forth in the Rate Book of Fees and Charges, located in the City Clerk's Office. All fees must be paid by check, money order or cashiers check, made payable to the City Treasurer. Cash will not be accepted.
 - f. No fire hydrant meters shall be furnished or relocated for any customer with a delinquent account with the Water Department.
 - g. After the fees have been paid and an account has been created, the

CITY OF SAN DIEGO CALIFORNIA DEPARTMENT INSTRUCTIONS	NUMBER DI 55.27	DEPARTMENT Water Department
SUBJECT FIRE HYDRANT METER PROGRAM (FORMERLY: CONSTRUCTION METER PROGRAM)	PAGE 6 OF 10	EFFECTIVE DATE October 15, 2002
	SUPERSEDES DI 55.27	DATED April 21, 2000

meter shall be installed within 48 hours (by the second business day). For an additional fee, at overtime rates, meters can be installed within 24 hours (within one business day).

4.7 Relocation of Existing Fire Hydrant Meters

- a. The customer shall call the Fire Hydrant Meter Hotline (herein referred to as "Hotline"), a minimum of 24 hours in advance, to request the relocation of a meter. A fee will be charged to the existing account, which must be current before a work order is generated for the meter's relocation.
- b. The customer will supply in writing the address where the meter is to be relocated (map page, cross street, etc). The customer must update the original Fire Hydrant Meter Application with any changes as it applies to the new location.
- c. Fire hydrant meters shall be read on a monthly basis. While fire hydrant meters and backflow devices are in service, commodity, base fee and damage charges, if applicable, will be billed to the customer on a monthly basis. If the account becomes delinquent, the meter will be removed.

4.8 Disconnection of Fire Hydrant Meter

- a. After ten (10) months a "Notice of Discontinuation of Service" (Tab 3) will be issued to the site and the address of record to notify the customer of the date of discontinuance of service. An extension can only be granted in writing from the Water Department Director for up to 90 additional days (as stated in Section 4.6C) and a copy of the extension shall be forwarded to the Meter Shop Supervisor. If an extension has not been approved, the meter will be removed after twelve (12) months of use.
- b. Upon completion of the project the customer will notify the Meter Services office via the Hotline to request the removal of the fire hydrant meter and appurtenances. A work order will be generated

CITY OF SAN DIEGO CALIFORNIA DEPARTMENT INSTRUCTIONS	NUMBER DI 55.27	DEPARTMENT Water Department
SUBJECT FIRE HYDRANT METER PROGRAM (FORMERLY: CONSTRUCTION METER PROGRAM)	PAGE 7 OF 10	EFFECTIVE DATE October 15, 2002
	SUPERSEDES DI 55.27	DATED April 21, 2000

for removal of the meter.

- c. Meter Section staff will remove the meter and backflow prevention assembly and return it to the Meter Shop. Once returned to the Meter Shop the meter and backflow will be tested for accuracy and functionality.
- d. Meter Section Staff will contact and notify Customer Services of the final read and any charges resulting from damages to the meter and backflow or its appurtenance. These charges will be added on the customer's final bill and will be sent to the address of record. Any customer who has an outstanding balance will not receive additional meters.
- e. Outstanding balances due may be deducted from deposits and any balances refunded to the customer. Any outstanding balances will be turned over to the City Treasurer for collection. Outstanding balances may also be transferred to any other existing accounts.

5. **EXCEPTIONS**

- 5.1 Any request for exceptions to this policy shall be presented, in writing, to the Customer Support Deputy Director, or his/her designee for consideration.

6. **MOBILE METER**

- 6.1 Mobile meters will be allowed on a case by case basis. All mobile meters will be protected by an approved backflow assembly and the minimum requirement will be a Reduced Pressure Principal Assembly. The two types of Mobile Meters are vehicle mounted and floating meters. Each style of meters has separate guidelines that shall be followed for the customer to retain service and are described below:

- a) **Vehicle Mounted Meters:** Customer applies for and receives a City owned Fire Hydrant Meter from the Meter Shop. The customer mounts the meter on the vehicle and brings it to the Meter Shop for

CITY OF SAN DIEGO CALIFORNIA DEPARTMENT INSTRUCTIONS	NUMBER DI 55.27	DEPARTMENT Water Department
SUBJECT FIRE HYDRANT METER PROGRAM (FORMERLY: CONSTRUCTION METER PROGRAM)	PAGE 8 OF 10	EFFECTIVE DATE October 15, 2002
	SUPERSEDES DI 55.27	DATED April 21, 2000

inspection. After installation is approved by the Meter Shop the vehicle and meter shall be brought to the Meter Shop on a monthly basis for meter reading and on a quarterly basis for testing of the backflow assembly. Meters mounted at the owner's expense shall have the one year contract expiration waived and shall have meter or backflow changed if either fails.

- b) **Floating Meters:** Floating Meters are meters that are not mounted to a vehicle. (Note: All floating meters shall have an approved backflow assembly attached.) The customer shall submit an application and a letter explaining the need for a floating meter to the Meter Shop. The Fire Hydrant Meter Administrator, after a thorough review of the needs of the customer, (i.e. number of jobsites per day, City contract work, lack of mounting area on work vehicle, etc.), may issue a floating meter. At the time of issue, it will be necessary for the customer to complete and sign the "Floating Fire Hydrant Meter Agreement" which states the following:

- 1) The meter will be brought to the Meter Shop at 2797 Caminito Chollas, San Diego on the third week of each month for the monthly read by Meter Shop personnel.
- 2) Every other month the meter will be read and the backflow will be tested. This date will be determined by the start date of the agreement.

If any of the conditions stated above are not met the Meter Shop has the right to cancel the contract for floating meter use and close the account associated with the meter. The Meter Shop will also exercise the right to refuse the issuance of another floating meter to the company in question.

Any Fire Hydrant Meter using reclaimed water shall not be allowed use again with any potable water supply. The customer shall incur the cost of replacing the meter and backflow device in this instance.

CITY OF SAN DIEGO CALIFORNIA DEPARTMENT INSTRUCTIONS	NUMBER DI 55.27	DEPARTMENT Water Department
SUBJECT FIRE HYDRANT METER PROGRAM (FORMERLY: CONSTRUCTION METER PROGRAM)	PAGE 9 OF 10	EFFECTIVE DATE October 15, 2002
	SUPERSEDES DI 55.27	DATED April 21, 2000

7. FEE AND DEPOSIT SCHEDULES

7.1 **Fees and Deposit Schedules:** The fees and deposits, as listed in the Rate Book of Fees and Charges, on file with the Office of the City Clerk, are based on actual reimbursement of costs of services performed, equipment and materials. These deposits and fees will be amended, as needed, based on actual costs. Deposits, will be refunded at the end of the use of the fire hydrant meter, upon return of equipment in good working condition and all outstanding balances on account are paid. Deposits can also be used to cover outstanding balances.

All fees for equipment, installation, testing, relocation and other costs related to this program are subject to change without prior notification. The Mayor and Council will be notified of any future changes.

8. UNAUTHORIZED USE OF WATER FROM A HYDRANT

- 8.1 Use of water from any fire hydrant without a properly issued and installed fire hydrant meter is theft of City property. Customers who use water for unauthorized purposes or without a City of San Diego issued meter will be prosecuted.
- 8.2 If any unauthorized connection, disconnection or relocation of a fire hydrant meter, or other connection device is made by anyone other than authorized Water Department personnel, the person making the connection will be prosecuted for a violation of San Diego Municipal Code, Section 67.15. In the case of a second offense, the customer's fire hydrant meter shall be confiscated and/or the deposit will be forfeited.
- 8.3 Unauthorized water use shall be billed to the responsible party. Water use charges shall be based on meter readings, or estimates when meter readings are not available.
- 8.4 In case of unauthorized water use, the customer shall be billed for all applicable charges as if proper authorization for the water use had been obtained, including but not limited to bi-monthly service charges, installation charges and removal charges.

CITY OF SAN DIEGO CALIFORNIA DEPARTMENT INSTRUCTIONS	NUMBER DI 55.27	DEPARTMENT Water Department
SUBJECT FIRE HYDRANT METER PROGRAM (FORMERLY: CONSTRUCTION METER PROGRAM)	PAGE 10 OF 10	EFFECTIVE DATE October 15, 2002
	SUPERSEDES DI 55.27	DATED April 21, 2000

- 8.5 If damage occurs to Water Department property (i.e. fire hydrant meter, backflow, various appurtenances), the cost of repairs or replacements will be charged to the customer of record (applicant).

**Larry Gardner
Water Department Director**

- Tabs: 1. Fire Hydrant Meter Application
 2. Construction & Maintenance Related Activities With No Return To Sewer
 3. Notice of Discontinuation of Service

APPENDIX

Administering Division: Customer Support Division

Subject Index: Construction Meters
 Fire Hydrant
 Fire Hydrant Meter Program
 Meters, Floating or Vehicle Mounted
 Mobile Meter
 Program, Fire Hydrant Meter

Distribution: DI Manual Holders



Application for Fire Hydrant Meter (EXHIBIT A)

(For Office Use Only)

NS REQ	FAC#
DATE	BY

METER SHOP (619) 527-7449

Meter Information

Application Date	Requested Install Date:
------------------	-------------------------

Fire Hydrant Location: (Attach Detailed Map//Thomas Bros. Map Location or Construction drawing.) <u>Zip:</u>	<u>T.B.</u>	<u>G.B. (CITY USE)</u>
Specific Use of Water:		
Any Return to Sewer or Storm Drain, if so, explain:		
Estimated Duration of Meter Use: <input type="text"/>	<input type="checkbox"/>	Check Box if Reclaimed Water

Company Information

Company Name:			
Mailing Address:			
City:	State:	Zip:	Phone: ()
*Business license#		*Contractor license#	
A Copy of the Contractor's license OR Business License is required at the time of meter issuance.			
Name and Title of Billing Agent: <small>(PERSON IN ACCOUNTS PAYABLE)</small>			Phone: ()
Site Contact Name and Title:			Phone: ()
Responsible Party Name:			Title:
Cal ID#			Phone: ()
Signature:		Date:	
Guarantees Payment of all Charges Resulting from the use of this Meter. Insures that employees of this Organization understand the proper use of Fire Hydrant Meter			

Fire Hydrant Meter Removal Request	Requested Removal Date:
Provide Current Meter Location if Different from Above:	
Signature:	Title: Date:
Phone: ()	Pager: ()

<input type="checkbox"/>	City Meter	<input type="checkbox"/>	Private Meter
Contract Acct #:		Deposit Amount: \$ 936.00	Fees Amount: \$ 62.00
Meter Serial #		Meter Size: 05	Meter Make and Style: 6-7
Backflow #		Backflow Size:	Backflow Make and Style:
Name:		Signature:	Date:

WATER USES WITHOUT ANTICIPATED CHARGES FOR RETURN TO SEWER

Auto Detailing
Backfilling
Combination Cleaners (Vactors)
Compaction
Concrete Cutters
Construction Trailers
Cross Connection Testing
Dust Control
Flushing Water Mains
Hydro Blasting
Hydro Seeing
Irrigation (for establishing irrigation only; not continuing irrigation)
Mixing Concrete
Mobile Car Washing
Special Events
Street Sweeping
Water Tanks
Water Trucks
Window Washing

Note:

1. If there is any return to sewer or storm drain, then sewer and/or storm drain fees will be charges.

Date

Name of Responsible Party
Company Name and Address
Account Number: _____

Subject: Discontinuation of Fire Hydrant Meter Service

Dear Water Department Customer:

The authorization for use of Fire Hydrant Meter # _____, located at *(Meter Location Address)* ends in 60 days and will be removed on or after *(Date Authorization Expires)*. Extension requests for an additional 90 days must be submitted in writing for consideration 30 days prior to the discontinuation date. If you require an extension, please contact the Water Department, or mail your request for an extension to:

City of San Diego
Water Department
Attention: Meter Services
2797 Caminito Chollas
San Diego, CA 92105-5097

Should you have any questions regarding this matter, please call the Fire Hydrant Hotline at (619) _____ - _____.

Sincerely,

Water Department

APPENDIX C

MATERIALS TYPICALLY ACCEPTED BY CERTIFICATE OF COMPLIANCE

Materials Typically Accepted by Certificate of Compliance

1. Soil amendment
2. Fiber mulch
3. PVC or PE pipe up to 16 inch diameter
4. Stabilizing emulsion
5. Lime
6. Preformed elastomeric joint seal
7. Plain and fabric reinforced elastomeric bearing pads
8. Steel reinforced elastomeric bearing pads
9. Waterstops (Special Condition)
10. Epoxy coated bar reinforcement
11. Plain and reinforcing steel
12. Structural steel
13. Structural timber and lumber
14. Treated timber and lumber
15. Lumber and timber
16. Aluminum pipe and aluminum pipe arch
17. Corrugated steel pipe and corrugated steel pipe arch
18. Structural metal plate pipe arches and pipe arches
19. Perforated steel pipe
20. Aluminum underdrain pipe
21. Aluminum or steel entrance tapers, pipe downdrains, reducers, coupling bands and slip joints
22. Metal target plates
23. Paint (traffic striping)
24. Conductors
25. Painting of electrical equipment
26. Electrical components
27. Engineering fabric
28. Portland Cement
29. PCC admixtures
30. Minor concrete, asphalt
31. Asphalt (oil)
32. Liquid asphalt emulsion
33. Epoxy

APPENDIX D

SAMPLE CITY INVOICE

City of San Diego, Field Engineering Div., 9485 Aero Drive, SD CA 92123		Contractor's Name:	
Project Name:		Contractor's Address:	
Work Order No or Job Order No.			
City Purchase Order No.		Contractor's Phone #:	Invoice No.
Resident Engineer (RE):		Contractor's fax #:	Invoice Date:
RE Phone#:	Fax#:	Contact Name:	Billing Period: (to

Item #	Item Description	Contract Authorization				Previous Totals To Date		This Estimate		Totals to Date	
		Unit	Price	Qty	Extension	%/QTY	Amount	% / QTY	Amount	% / QTY	Amount
1					\$ -		\$ -		\$ -	0.00%	\$ -
2					\$ -		\$ -		\$ -	0.00%	\$ -
3					\$ -		\$ -		\$ -	0.00%	\$ -
4					\$ -		\$ -		\$ -	0.00%	\$ -
5					\$ -		\$ -		\$ -	0.00%	\$ -
6					\$ -		\$ -		\$ -	0.00%	\$ -
7					\$ -		\$ -		\$ -	0.00%	\$ -
8					\$ -		\$ -		\$ -	0.00%	\$ -
9					\$ -		\$ -		\$ -	0.00%	\$ -
10					\$ -		\$ -		\$ -	0.00%	\$ -
11					\$ -		\$ -		\$ -	0.00%	\$ -
12					\$ -		\$ -		\$ -	0.00%	\$ -
13					\$ -		\$ -		\$ -	0.00%	\$ -
14					\$ -		\$ -		\$ -	0.00%	\$ -
15					\$ -		\$ -		\$ -	0.00%	\$ -
16					\$ -		\$ -		\$ -	0.00%	\$ -
17	Field Orders				\$ -		\$ -		\$ -	0.00%	\$ -
18					\$ -		\$ -		\$ -	0.00%	\$ -
	CHANGE ORDER No.				\$ -		\$ -		\$ -	0.00%	\$ -
					\$ -		\$ -		\$ -	0.00%	\$ -
Total Authorized Amount (including approved Change Order)					\$ -		\$ -		\$ -	Total Billed	\$ -

SUMMARY

A. Original Contract Amount	\$ -
B. Approved Change Order #00 Thru #00	\$ -
C. Total Authorized Amount (A+B)	\$ -
D. Total Billed to Date	\$ -
E. Less Total Retention (5% of D)	\$ -
F. Less Total Previous Payments	\$ -
G. Payment Due Less Retention	\$0.00
H. Remaining Authorized Amount	\$0.00

**I certify that the materials
have been received by me in
the quality and quantity specified**

Resident Engineer

Construction Engineer

Retention and/or Escrow Payment Schedule

Total Retention Required as of this billing (Item E)	\$0.00
Previous Retention Withheld in PO or in Escrow	\$0.00
Add'l Amt to Withhold in PO/Transfer in Escrow:	\$0.00
Amt to Release to Contractor from PO/Escrow:	

Contractor Signature and Date: _____

APPENDIX E
LOCATION MAPS

The City of **SAN DIEGO** Public Works

SEWER & AC WATER GROUP 821
SEWER & AC WATER GROUP 764

SENIOR ENGINEER
 NABIL BATTA
 (619) 533-4145

PROJECT MANAGER
 ROBERTO VEJAR-PARRA
 (619) 533-5402

PROJECT ENGINEER
 JING DEBELISO
 (619) 533-5285

FOR QUESTIONS ABOUT THIS PROJECT
 Call: (619) 533-4207
 Email: engineering@sandiego.gov

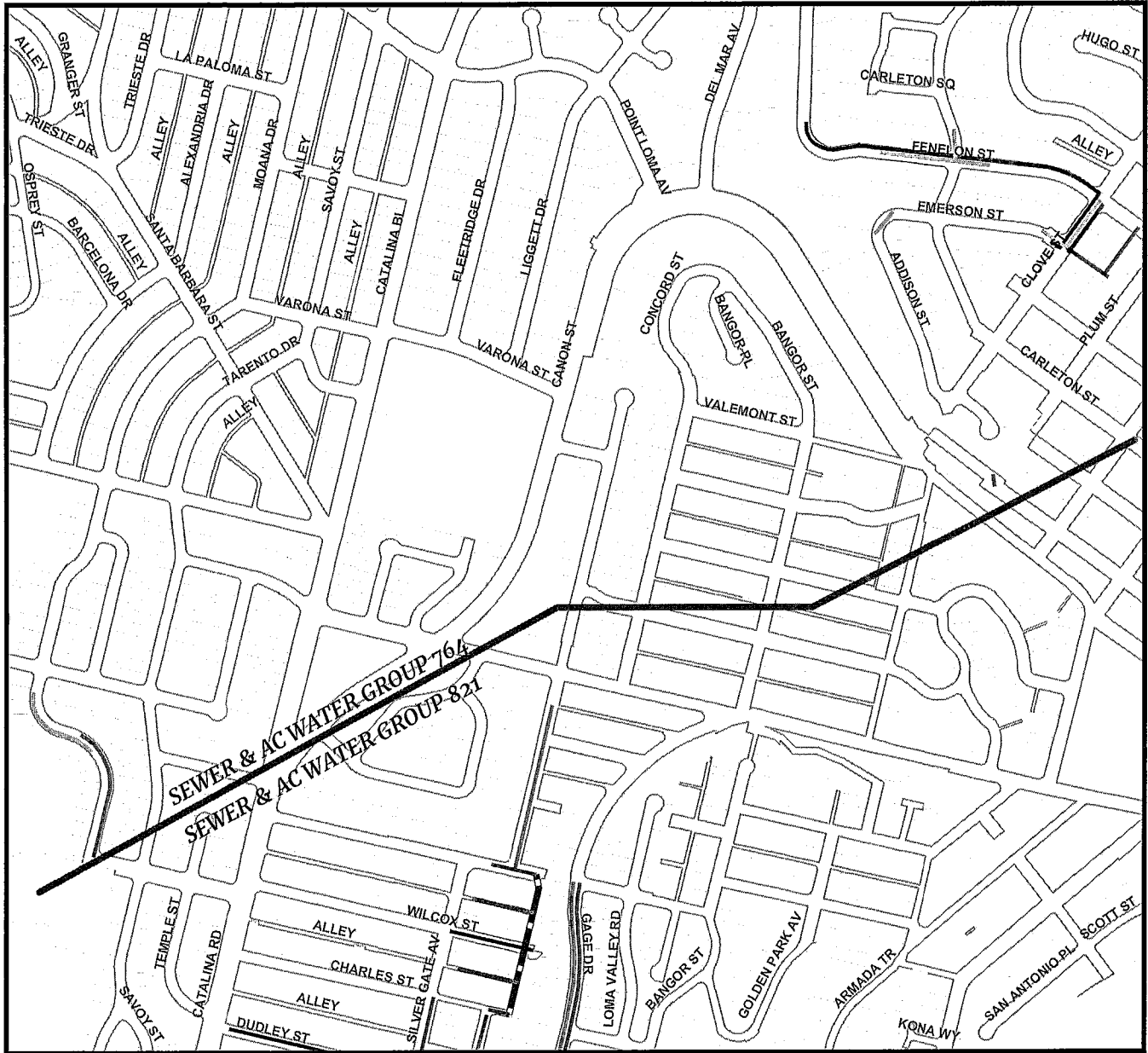
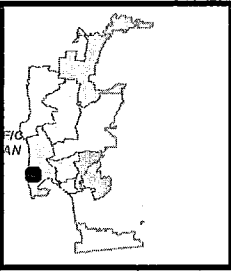

Legend

- SWR & AC WTR GRP 821_SEWER
- SWR & AC WTR GRP 821_WATER
- SEWER & AC WATER GRP 821_8 INCH VC SEWER REHAB
- SWR & AC WTR GRP 764_SEWER
- SWR & AC WTR GRP 764_WATER
- SWR & AC WTR GRP 764_6 & 8 INCH VC SEWER REHAB

LOCATION MAP 1 OF 2



COMMUNITY NAME: PENINSULA AREA

COUNCIL DISTRICT: 2

SAP ID: GJ 821 B00413 (S)\B15107 (W)

Date: AUGUST 23, 2016
 Sewer & AC Water GJ 764 & 821
 Appendix E - Location Maps



SAP ID: GJ 764 B00368 (S)\B15106 (W)
 150 | Page

THIS MAP/DATA IS PROVIDED WITHOUT WARRANTY OF ANY KIND, EITHER EXPRESS OR IMPLIED, INCLUDING, BUT NOT LIMITED TO, THE IMPLIED WARRANTIES OR MERCHANTABILITY AND FITNESS FOR A PARTICULAR PURPOSE. Note: This product may contain information reproduced with permission granted by RAND MCNALLY & COMPANY to SanGIS. This map is copyrighted by RAND MCNALLY & COMPANY. It is unlawful to copy or reproduce all or any part thereof, whether for personal use or resale, without the prior, written permission of RAND MCNALLY & COMPANY.

The City of **SAN DIEGO** Public Works

SEWER & AC WATER GROUP 821
SEWER & AC WATER GROUP 764

SENIOR ENGINEER
NABIL BATTA
(619) 533-4145

PROJECT MANAGER
ROBERTO VEJAR-PARRA
(619) 533-5402

PROJECT ENGINEER
JING DEBELISO
(619) 533-5285

FOR QUESTIONS ABOUT THIS PROJECT
Call: (619) 533-4207
Email: engineering@sandiego.gov

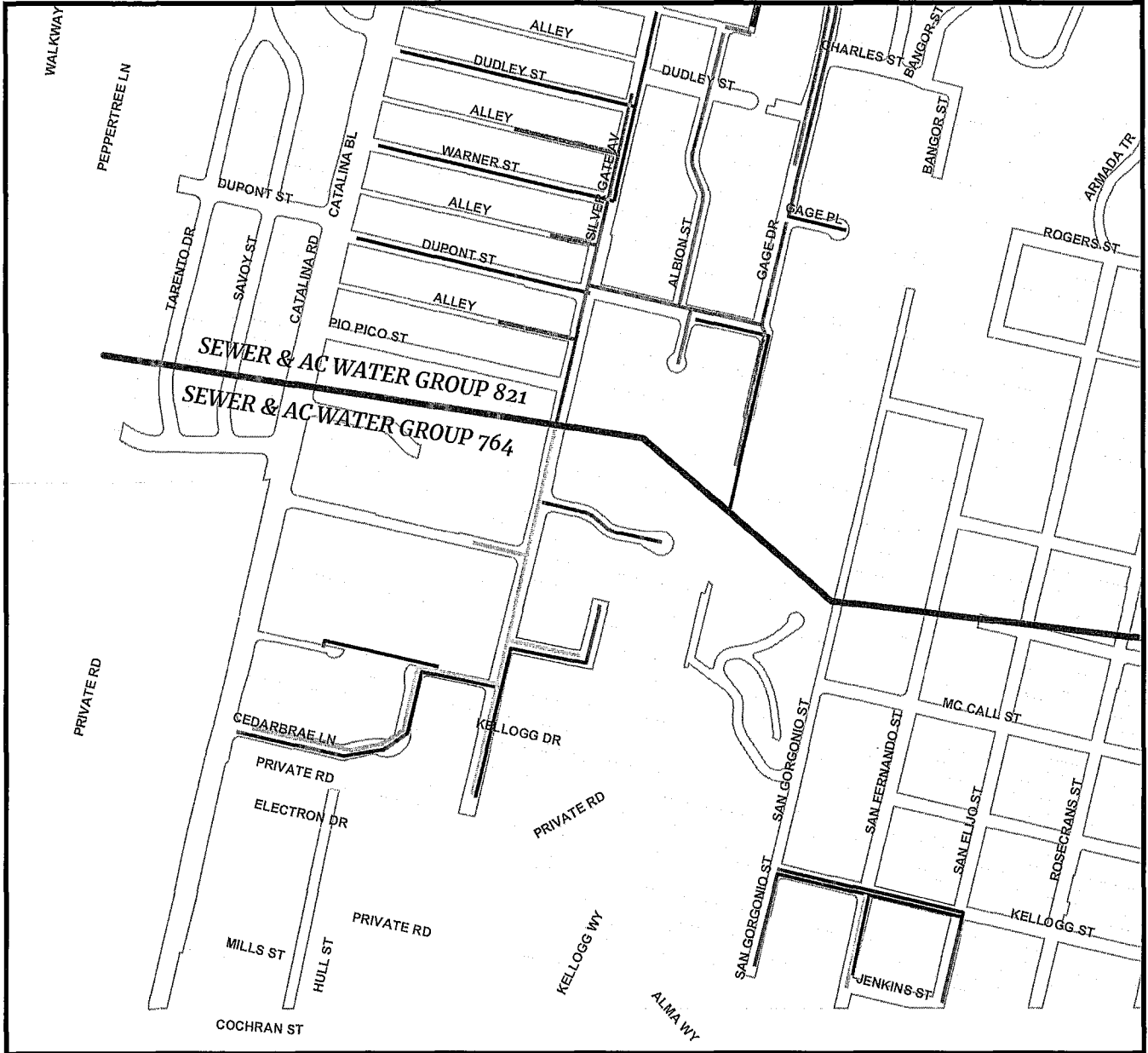
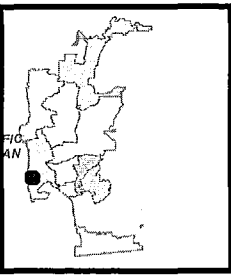

Legend

LOCATION MAP 2 OF 2

- SWR & AC WTR GRP 821_SEWER
- SWR & AC WTR GRP 821_WATER
- SWR & AC WTR GRP 764_SEWER
- SEWER & AC WATER GRP 821_8 INCH VC SEWER REHAB
- SWR & AC WTR GRP 764_WATER
- SWR & AC WTR GRP 764_6 & 8 INCH VC SEWER REHAB

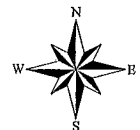

COMMUNITY NAME: PENINSULA AREA

COUNCIL DISTRICT: 2

SAP ID: GJ 821 B00413 (S)\B15107 (W)

Date: AUGUST 23, 2016
Sewer & AC Water GJ 764 & 821



SAP ID: GJ 764 B00368 (S)\B15106 (W)

Appendix E - Location Maps

THIS MAP/DATA IS PROVIDED WITHOUT WARRANTY OF ANY KIND, EITHER EXPRESS OR IMPLIED, INCLUDING, BUT NOT LIMITED TO, THE IMPLIED WARRANTIES OR MERCHANTABILITY AND FITNESS FOR A PARTICULAR PURPOSE. Note: This product may contain information reproduced with permission granted by RAND MCNALLY & COMPANY to SAGIS. This map is copyrighted by RAND MCNALLY & COMPANY. It is unlawful to copy or reproduce all or any part thereof, whether for personal use or resale, without the prior, written permission of RAND MCNALLY & COMPANY.

APPENDIX F
ADJACENT PROJECTS

The City of
SAN DIEGO Public Works

LOCATION MAP

**CATALINA BLVD 12" WATER and
CATALINA SEWER MAIN**

SENIOR ENGINEER
MICHAEL NINH
(619) 533-7443

PROJECT MANAGER
JOE MYERS
(619) 533-6632

PROJECT ENGINEER
JESS ARCILLAS
(619) 533-4625

CONSTRUCTION PROJECT
INFORMATION LINE
(619) 533-4207

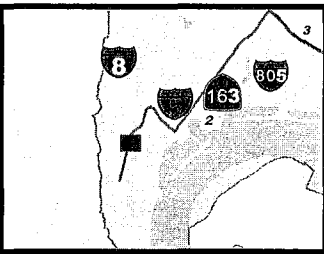

Legend

- NEW STORM DRAIN
- WATER - REPLACE
- SEWER - REPLACE
- NEW SEWER
- Add Alternate Sewer



1 in.:900 ft.

S:\ROWD\ROWD-Section-4-WaterandWastewaterPipelines\Catalina\Joe's Format\Location map\update w alternate 02112015\Design Location Map (02-11-2015).mxd

Community Name: Peninsula

Council District: 2



SAP ID# S12008 (W)

B13216 (S)

Date:04/04/2016

Sewer & AC Water GJ 764 & 821 Appendix F - Adjacent Projects

THIS MAP/DATA IS PROVIDED WITHOUT WARRANTY OF ANY KIND, EITHER EXPRESS OR IMPLIED, INCLUDING, BUT NOT LIMITED TO, THE IMPLIED WARRANTIES OR MERCHANTABILITY AND FITNESS FOR A PARTICULAR PURPOSE. Note: This product may contain information reproduced with permission granted by RAND MCNALLY & COMPANY to SanGIS. This map is copyrighted by RAND MCNALLY & COMPANY. It is unlawful to copy or reproduce all or any part thereof, whether for personal use or resale, without the prior, written permission of RAND MCNALLY & COMPANY.

The City of
SAN DIEGO Public Works

AC WATER AND SEWER GROUP 1017

SENIOR ENGINEER
 SHEILA BOSE
 (619) 533-4698

PROJECT MANAGER
 ELHAM LOTFI
 (619) 533-5212

PROJECT ENGINEER
 OMAR BELTRAN
 (619) 533-4127

FOR QUESTIONS ABOUT THIS PROJECT
 Call: (619) 533-4207
 Email: engineering@sandiego.gov

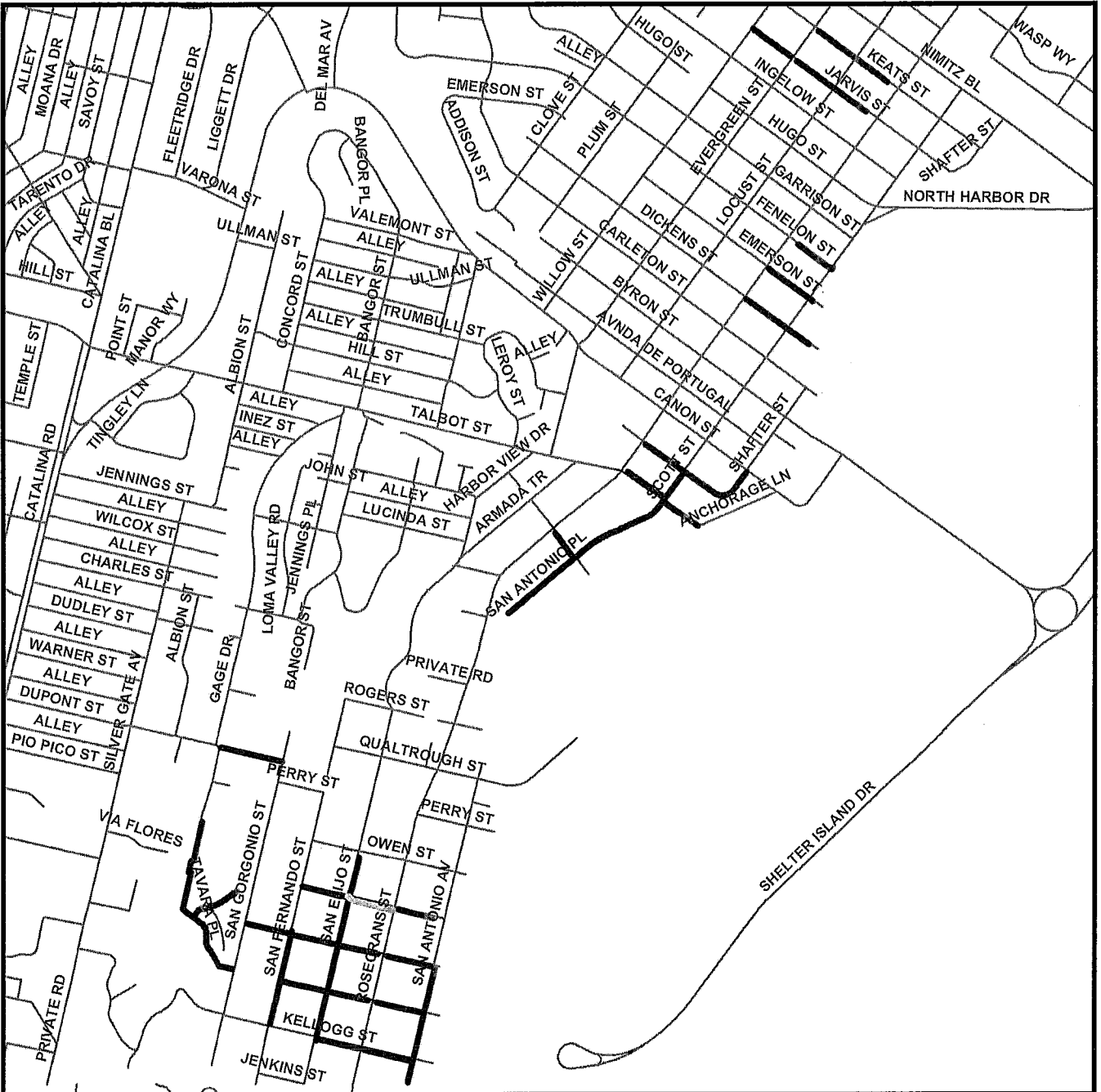
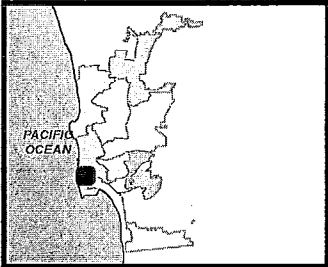

Legend

- SEWER_GJ1017
- WATER_GJ1017

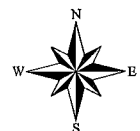

COMMUNITY NAME: PENINSULA
 Date: November 8, 2016

COUNCIL DISTRICT: 2



SAP ID: B15119 (W) \\
 B15116 (S)

THIS MAP/DATA IS PROVIDED WITHOUT WARRANTY OF ANY KIND, EITHER EXPRESS OR IMPLIED, INCLUDING, BUT NOT LIMITED TO, THE IMPLIED WARRANTIES OR MERCHANTABILITY AND FITNESS FOR A PARTICULAR PURPOSE. Note: This product may contain information reproduced with permission granted by RAND McNALLY & COMPANY to SANDAG. This map is copyrighted by RAND McNALLY & COMPANY. It is unlawful to copy or reproduce all or any part thereof, whether for personal use or resale, without the prior, written permission of RAND McNALLY & COMPANY.

APPENDIX G
HYDROSTATIC DISCHARGE FORM

Hydrostatic Discharge Requirements Certification (Discharge Events \geq 325,850 gpd)

All discharge activities related to this project comply with the Regional Water Quality Control Board (RWQCB) Order No. R9-2010-0003, General Permit for Discharges of Hydrostatic Test Water and Potable Water to Surface Water and Storm Drains as referenced by (http://www.waterboards.ca.gov/sandiego/board_decisions/adopted_orders/2010/R9-2010-0003.pdf), and as follows:

Discharged water has been dechlorinated to below <u>0.1</u> (mg/l) level; and effluent has been maintained between <u>6 and 9</u> (pH) based on:							Is Discharge Within Limits?		Comment/Action Taken
Event #	Discharge Date	Item Tested	Duration	Amount (gpd)	Description of the Proposed Discharge	Method and Test Result	YES	NO	
		Chlorine							
		pH							
		Chlorine							
		pH							
		Chlorine							
		pH							
		Chlorine							
		pH							

Qualified Personnel Conducting Tests (Print Name): _____ **SAP No.(s):** _____

***Signed:** _____ **Project Name:** _____

* By signing, I hereby certify and affirm under penalty of perjury that all of the statements and conditions for hydrostatic discharge events are correct.

Have any thresholds been exceeded? Per Order No. R9-2010-0003, would this be a reportable discharge and must be reported **within 24 hours** of the event? [Reportable discharge would include violation of maximum gallons per day, any upset which exceeds any effluent limit]

APPENDIX H
DISCHARGE POINTS AND FLOW DATA

CITY OF SAN DIEGO
HYDRAULIC MODEL RESULTS TABLE
MAINS 31 - BASIN C21S3
2035 DWF AS-BUILT

FACILITY SEQUENCE NUMBER	PIPE ID	DOWNSTREAM MH ID	UPSTREAM MH INV. EL (FT)	DOWNSTREAM MH INV. EL (FT)	DOWNSTREAM MH RIM EL (FT)	PIPE SLOPE (FT/FT)	PIPE DIAMETER (IN)	PIPE LENGTH (FT)	MAX. VELOCITY (FT/SEC)	MAX. DEPTH (IN)	MAX. d/D (%)	MAX. HGL EL (FT)	MAX. EGL EL (FT)	HGL DEPTH BELOW RIM (FT)	AVG. FLOW (GPD)	MAX. FLOW (GPD)	FULL CAPACITY (GPD)	MAX. Q/CAP (%)	TASK AREA
5837	B22S67.1	B22S66	340.03	339.43	350.43	0.010	8	60	0.02	0.88	11.0	339.50	339.50	10.93	150	600	781,052	0.1	12038
5888	B22S140.3	B22S146	304.00	294.00	303.00	0.032	8	310	0.08	0.83	10.4	294.07	294.07	8.93	550	2,200	1,402,880	0.2	
5918	B22S174.1	B22S166	303.00	290.68	298.68	0.036	6	340	0.19	0.94	15.6	290.76	290.76	7.92	1,250	5,000	690,398	0.7	
5887	B22S231.2	B22S146	296.00	294.00	303.00	0.014	6	140	0.05	0.83	13.9	294.07	294.07	8.93	300	1,200	433,506	0.3	
5886	B22S146.1	B22S145	294.00	287.12	296.12	0.037	8	187	0.16	0.93	11.6	287.20	287.20	8.92	1,200	4,800	1,498,172	0.3	
5919	B22S165.2	B22S166	293.00	290.68	298.68	0.011	6	220	0.13	0.94	15.6	290.76	290.76	7.92	850	3,400	372,471	0.9	
5917	B22S166.3	B22S169	290.68	288.26	295.26	0.007	6	345	0.40	0.99	16.4	288.34	288.35	6.92	2,850	11,400	303,784	3.8	
5916	B22S170.2	B22S169	289.70	288.26	295.26	0.010	6	140	0.06	0.99	16.4	288.34	288.34	6.92	450	1,800	367,834	0.5	
5915	B22S169.1	B22S145	288.26	287.12	296.12	0.007	6	163	0.56	0.93	15.5	287.20	287.20	8.92	3,700	14,800	303,321	4.9	
5885	B22S145.3	B22S144	287.12	275.11	283.11	0.036	8	333	0.48	1.20	15.0	275.21	275.22	7.90	5,400	21,600	1,483,333	1.5	
5881	B22S134.2	B22S142	281.27	277.36	281.72	0.012	8	338	0.07	0.86	10.8	277.43	277.43	4.29	500	2,000	840,117	0.2	
5882	B22S142.1	B22S141	277.36	276.19	284.19	0.004	8	288	0.14	0.85	10.7	276.26	276.26	7.93	950	3,800	497,845	0.8	
5883	B22S141.2	B22S143	276.19	275.27	281.27	0.005	8	179	0.14	0.88	11.0	275.34	275.34	5.93	950	3,800	559,981	0.7	
5884	B22S143.2	B22S144	275.27	275.11	283.11	0.004	8	40	0.10	1.20	15.0	275.21	275.21	7.90	1,150	4,600	494,019	0.9	
5914	B22S144.2	B22S168	275.11	273.45	281.45	0.004	8	395	1.25	1.35	16.9	273.56	273.59	7.89	7,850	31,400	506,365	6.2	
5913	B22S168.1	B22S167	273.45	272.65	282.65	0.004	8	200	1.25	1.41	17.6	272.77	272.79	9.88	8,350	33,400	494,019	6.8	
5912	B22S167.2	B22S163	272.65	270.72	280.72	0.004	8	482	1.30	1.50	18.7	270.84	270.87	9.88	9,450	37,800	494,251	7.6	
5911	B22S163.2	C22S2	270.72	268.11	276.11	0.022	8	119	1.07	1.07	13.4	268.20	268.22	7.91	10,250	41,000	1,156,769	3.5	
11174	C22S2.1	C21S380	268.11	265.10	272.10	0.021	8	143	1.00	1.12	14.0	265.19	265.21	6.91	10,250	41,000	1,133,236	3.6	
5695	B21S229.2	C21S380	267.70	265.10	272.10	0.010	6	255	0.14	1.12	18.7	265.19	265.19	6.91	1,200	4,800	366,211	1.3	
11198	C22S407.2	C22S43	267.05	255.25	263.60	0.044	8	270	0.09	0.84	10.5	255.32	255.32	8.28	600	2,400	1,632,878	0.1	
11080	C21S380.3	C21S378	265.10	259.19	264.19	0.018	8	330	0.89	1.35	16.9	259.30	259.31	4.89	12,050	48,200	1,045,306	4.6	
5704	B21S232.2	C21S378	261.70	259.19	264.19	0.010	6	252	0.13	1.35	22.5	259.30	259.30	4.89	1,400	5,600	361,979	1.5	
5705	B21S249.2	C21S376	259.50	258.12	270.12	0.011	6	130	0.03	1.15	19.2	258.22	258.22	11.91	250	1,000	373,688	0.3	
11078	C21S378.3	C21S375	259.19	258.48	265.48	0.006	8	117	1.67	1.63	20.3	258.62	258.66	6.86	13,750	55,000	608,438	9.0	
11077	C21S375.3	C21S376	258.48	258.12	270.12	0.004	8	89	1.45	1.80	22.5	258.27	258.30	11.85	13,750	55,000	496,744	11.1	
11076	C21S376.1	C21S369	258.12	251.09	259.09	0.022	8	317	2.73	1.24	15.6	251.19	251.31	7.90	15,300	60,996	1,163,145	5.2	
11195	C22S43.1	C22S42	255.25	243.14	250.90	0.052	8	231	0.26	0.85	10.7	243.21	243.21	7.69	1,750	7,000	1,788,393	0.4	
11075	C21S369.2	C21S335	251.09	223.00	228.00	0.060	8	468	1.80	1.05	13.1	223.09	223.14	4.91	17,250	67,275	1,913,593	3.5	
11194	C22S42.2	C22S4	243.14	226.51	233.51	0.062	8	270	0.35	0.93	11.6	226.59	226.59	6.92	2,700	10,800	1,938,459	0.6	
11176	C22S4.2	C22S3	226.51	225.19	232.19	0.012	8	111	0.38	0.98	12.2	225.27	225.27	6.92	3,150	12,600	851,767	1.5	
11175	C22S3.3	C22S1	225.19	222.91	227.91	0.013	8	179	0.57	0.97	12.1	222.99	223.00	4.92	4,650	18,600	881,502	2.1	
11079	C22S1.2	C21S379	222.91	216.12	223.00	0.025	8	271	0.78	0.95	11.8	216.20	216.21	6.80	6,200	24,800	1,236,352	2.0	
11081	C21S379.2	C21S374	216.12	204.12	211.00	0.050	8	241	0.83	1.03	12.9	204.21	204.22	6.79	7,400	29,600	1,742,892	1.7	

TOTAL LENGTH (MILES):	12.13	LENGTH OF PIPE - d/D < 50% (MILES):	11.54	LENGTH OF PIPE - Q/CAP < 50% (MILES):	11.89
LENGTH WEIGHTED Q/CAP:	5.7	LENGTH OF PIPE - d/D 50 - 75% (MILES):	0.54	LENGTH OF PIPE - Q/CAP 50 - 75% (MILES):	0.24
LENGTH WEIGHTED d/D:	19.3	LENGTH OF PIPE - d/D 75 - 100% (MILES):	0.04	LENGTH OF PIPE - Q/CAP 75 - 100% (MILES):	0.00
LENGTH WEIGHTED HGL BELOW RIM (FT):	7.59	LENGTH OF PIPE - d/D > 100% (MILES):	0.00	LENGTH OF PIPE - Q/CAP > 100% (MILES):	0.00

Note: Boxed records indicate condition assessed segments.

APPENDIX I
HAZARDOUS LABEL/FORMS

HAZARDOUS WASTE

STATE AND FEDERAL LAW PROHIBITS IMPROPER DISPOSAL
IF FOUND, CONTACT THE NEAREST POLICE, OR PUBLIC SAFETY
AUTHORITY, OR THE U.S. ENVIRONMENTAL PROTECTION AGENCY
OR THE CALIFORNIA DEPARTMENT OF HEALTH SERVICES

GENERATOR NAME _____
ADDRESS _____ 24 HR. PHONE () _____
CITY _____ STATE _____ ZIP _____
EPA ID NO. _____ MANIFEST DOCUMENT NO. _____
EPA WASTE NO. _____ CA WASTE NO. _____ ACCUMULATION START DATE _____ / ____ / ____

CONTENTS, COMPOSITION _____
PROPER DOT SHIPPING NAME _____
TECHNICAL NAME (S) _____
UNNA NO. WITH PREFIX _____

PHYSICAL STATE | HAZARDOUS PROPERTIES | FLAMMABLE | TOXIC
 SOLID | LIQUID | CORROSIVE | REACTIVE | OTHER _____

HANDLE WITH CARE!
CONTAINS HAZARDOUS OR TOXIC WASTES

INCIDENT/RELEASE ASSESSMENT FORM ¹

If you have an emergency, Call 911

Handlers of hazardous materials are required to report releases. The following is a tool to be used for assessing if a release is reportable. Additionally, a non-reportable release incident form is provided to document why a release is not reported (see back).

Questions for Incident Assessment:

	YES	NO
1. Was anyone killed or injured, or did they require medical care or admitted to a hospital for observation?	<input type="checkbox"/>	<input type="checkbox"/>
2. Did anyone, other than employees in the immediate area of the release, evacuate?	<input type="checkbox"/>	<input type="checkbox"/>
3. Did the release cause off-site damage to public or private property?	<input type="checkbox"/>	<input type="checkbox"/>
4. Is the release greater than or equal to a reportable quantity (RQ)?	<input type="checkbox"/>	<input type="checkbox"/>
5. Was there an uncontrolled or unpermitted release to the air?	<input type="checkbox"/>	<input type="checkbox"/>
6. Did an uncontrolled or unpermitted release escape secondary containment, or extend into any sewers, storm water conveyance systems, utility vaults and conduits, wetlands, waterways, public roads, or off site?	<input type="checkbox"/>	<input type="checkbox"/>
7. Will control, containment, decontamination, and/or clean up require the assistance of federal, state, county, or municipal response elements?	<input type="checkbox"/>	<input type="checkbox"/>
8. Was the release or threatened release involving an unknown material or contains an unknown hazardous constituent?	<input type="checkbox"/>	<input type="checkbox"/>
9. Is the incident a threatened release (a condition creating a substantial probability of harm that requires immediate action to prevent, reduce, or mitigate damages to persons, property, or the environment)?	<input type="checkbox"/>	<input type="checkbox"/>
10. Is there an increased potential for secondary effects including fire, explosion, line rupture, equipment failure, or other outcomes that may endanger or cause exposure to employees, the general public, or the environment?	<input type="checkbox"/>	<input type="checkbox"/>

If the answer is YES to any of the above questions – report the release to the California Office of Emergency Services at 800-852-7550 and the local CUPA daytime: (619) 338-2284, after hours: (858) 565-5255. Note: other state and federal agencies may require notification depending on the circumstances.

Call 911 in an emergency

If all answers are NO, complete a Non Reportable Release Incident Form (page 2 of 2) and keep readily available. Documenting why a “no” response was made to each question will serve useful in the event questions are asked in the future, and to justify not reporting to an outside regulatory agency.

If in doubt, report the release.

¹ This document is a guide for accessing when hazardous materials release reporting is required by Chapter 6.95 of the California Health and Safety Code. It does not replace good judgment, Chapter 6.95, or other state or federal release reporting requirements.

EMERGENCY RELEASE FOLLOW - UP NOTICE REPORTING FORM

A	BUSINESS NAME	FACILITY EMERGENCY CONTACT & PHONE NUMBER () -
B	INCIDENT DATE MO DAY YR	TIME NOTIFIED OES CONTROL NO. (use 24 hr time)
C	INCIDENT ADDRESS LOCATION	CITY / COMMUNITY COUNTY ZIP
D	CHEMICAL OR TRADE NAME (print or type)	CAS Number
E	CHECK IF CHEMICAL IS LISTED IN 40 CFR 355, APPENDIX A <input type="checkbox"/>	CHECK IF RELEASE REQUIRES NOTIFICATION UNDER 42 U.S.C. Section 9603 (a) <input type="checkbox"/>
F	PHYSICAL STATE CONTAINED <input type="checkbox"/> SOLID <input type="checkbox"/> LIQUID <input type="checkbox"/> GAS	PHYSICAL STATE RELEASED <input type="checkbox"/> SOLID <input type="checkbox"/> LIQUID <input type="checkbox"/> GAS
G	ENVIRONMENTAL CONTAMINATION <input type="checkbox"/> AIR <input type="checkbox"/> WATER <input type="checkbox"/> GROUND <input type="checkbox"/> OTHER	QUANTITY RELEASED TIME OF RELEASE DURATION OF RELEASE — DAYS — HOURS — MINUTES
H	ACTIONS TAKEN	
I	KNOWN OR ANTICIPATED HEALTH EFFECTS (Use the comments section for addition information) <input type="checkbox"/> ACUTE OR IMMEDIATE (explain) _____ <input type="checkbox"/> CHRONIC OR DELAYED (explain) _____ <input type="checkbox"/> NOTKNOWN (explain) _____	
J	ADVICE REGARDING MEDICAL ATTENTION NECESSARY FOR EXPOSED INDIVIDUALS	
K	COMMENTS (INDICATE SECTION (A - G) AND ITEM WITH COMMENTS OR ADDITIONAL INFORMATION)	
L	CERTIFICATION: I certify under penalty of law that I have personally examined and I am familiar with the information submitted and believe the submitted information is true, accurate, and complete. REPORTING FACILITY REPRESENTATIVE (print or type) _____ SIGNATURE OF REPORTING FACILITY REPRESENTATIVE _____ DATE: _____	

EMERGENCY RELEASE FOLLOW-UP NOTICE REPORTING FORM INSTRUCTIONS

GENERAL INFORMATION:

Chapter 6.95 of Division 20 of the California Health and Safety Code requires that written emergency release follow-up notices prepared pursuant to 42 U.S.C. § 11004, be submitted using this reporting form. Non-permitted releases of reportable quantities of Extremely Hazardous Substances (listed in 40 CFR 355, appendix A) or of chemicals that require release reporting under section 103(a) of the Comprehensive Environmental Response, Compensation, and Liability Act of 1980 [42 U.S.C. § 9603(a)] must be reported on the form, as soon as practicable, but no later than 30 days, following a release. The written follow-up report is required in addition to the verbal notification.

BASIC INSTRUCTIONS:

- The form, when filled out, reports follow-up information required by 42 U.S.C § 11004. Ensure that all information requested by the form is provided as completely as possible.
- If the incident involves reportable releases of more than one chemical, prepare one report form for each chemical released.
- If the incident involves a series of separate releases of chemical(s) at different times, the releases should be reported on separate reporting forms.

SPECIFIC INSTRUCTIONS:

Block A: Enter the name of the business and the name and phone number of a contact person who can provide detailed facility information concerning the release.

Block B: Enter the date of the incident and the time that verbal notification was made to OES. The OES control number is provided to the caller by OES at the time verbal notification is made. Enter this control number in the space provided.

Block C: Provide information pertaining to the location where the release occurred. Include the street address, the city or community, the county and the zip code.

Block D: Provide information concerning the specific chemical that was released. Include the chemical or trade name and the Chemical Abstract Service (CAS) number. Check all categories that apply. Provide best available information on quantity, time and duration of the release.

Block E: Indicate all actions taken to respond to and contain the release as specified in 42 U.S.C. § 11004(c).

Block F: Check the categories that apply to the health effects that occurred or could result from the release. Provide an explanation or description of the effects in the space provided. Use Block H for additional comments/information if necessary to meet requirements specified in 42 U.S.C. § 11004(c).

Block G: Include information on the type of medical attention required for exposure to the chemical released. Indicate when and how this information was made available to individuals exposed and to medical personnel, if appropriate for the incident, as specified in 42 U.S.C. § 11004(c).

Block H: List any additional pertinent information.

Block I: Print or type the name of the facility representative submitting the report. Include the official signature and the date that the form was prepared.

MAIL THE COMPLETED REPORT TO:

**State Emergency Response Commission (SERC)
Attn: Section 304 Reports
Hazardous Materials Unit
3650 Schriever Avenue
Mather, CA 95655**

NOTE: Authority cited: Sections 25503, 25503.1 and 25507.1, Health and Safety Code. Reference: Sections 25503(b)(4), 25503.1, 25507.1, 25518 and 25520, Health and Safety Code.

APPENDIX J

SEWER MAINS AND MANHOLE REHABILITATION SAMPLE DATA TEMPLATES

APPENDIX K

SAMPLE ARCHAEOLOGY INVOICE

(FOR ARCHAEOLOGY ONLY)

Company Name

Address, telephone, fax

Date: Insert Date

To: Name of Resident Engineer
City of San Diego
Field Engineering Division
9485 Aero Drive
San Diego, CA 92123-1801

Project Name: Insert Project Name

SAP Number (WBS/IO/CC): Insert SAP Number

Drawing Number: Insert Drawing Number

Invoice period: Insert Date to Insert Date

Work Completed: Bid item Number - Description of Bid Item - Quantity - Unit Price - Amount

Detailed summary of work completed under this bid item: Insert detailed description of Work related to Archaeology Monitoring Bid item. See Note 1 below.

Summary of charges:

Description of Services	Name	Start Date	End Date	Total Hours	Hourly Rate	Amount
Field Archaeologist	Joe Smith	8/29/2011	9/2/2011	40	\$84	\$3,360
Laboratory Assistant	Jane Doe	8/29/2011	9/2/2011	2	\$30	\$60
Subtotal						\$3,420

Work Completed: Bid item Number - Description of Bid Item - Quantity - Unit Price - Amount

Detailed summary of work completed under this bid item: Insert detailed description of Work related to Archaeology Curation/Discovery Bid item. See Note 2 below.

Summary of charges:

Description of Services	Where work occurred (onsite vs offsite/lab)	Name	Start Date	End Date	Total Hours	Hourly Rate	Amount

Field Archaeologist		Joe Smith	8/29/2011	9/2/2011	40	\$84	\$3,360
Laboratory Assistant		Jane Doe	8/29/2011	9/2/2011	2	\$30	\$60
Subtotal							\$3,420

Total this invoice: \$ _____

Total invoiced to date: \$ _____

SAMPLE

Note 1:

For monitoring related bid items or work please include summary of construction work that was monitored from Station to Station, Native American monitors present, MMC coordination, status and nature of monitoring and if any discoveries were made.

Note 2:

For curation/discovery related bid items or work completed as part of a discovery and curation process, the PI must provide a response to the following questions along with the invoice:

1. Preliminary results of testing including tentative recommendations regarding eligibility for listing in the California Register of Historical Resources (California Register).
 - a. Please briefly describe your application (consideration) of all four California Register criteria.
 - b. If the resource is eligible under Criterion D, please define the important information that may be present.
 - c. Were specialized studies performed? How many personnel were required? How many Native American monitors were present?
 - d. What is the age of the resource?
 - e. Please define types of artifacts to be collected and curated, including quantity of boxes to be submitted to the San Diego Archaeological Center (SDAC). How many personnel were required? How many Native American monitors were present?
2. Preliminary results of data recovery and a definition of the size of the representative sample.
 - a. Were specialized studies performed? Please define types of artifacts to be collected and curated, including quantity of boxes to be submitted to the SDAC. How many personnel were required? How many Native American monitors were present?
3. What resources were discovered during monitoring?
4. What is the landform context and what is the integrity of the resources?
5. What additional studies are necessary?
6. Based on application of the California Register criteria, what is the significance of the resources?
 - a. If the resource is eligible for the California Register, can the resource be avoided by construction?
 - b. If not, what treatment (mitigation) measures are proposed? Please define data to be recovered (if necessary) and what material will be submitted to the SDAC for curation. Are any specialized studies proposed?

(After the first invoice, not all the above information needs to be re-stated, just revise as applicable).

APPENDIX L

SAMPLE OF PUBLIC NOTICE

FOR SAMPLE REFERENCE ONLY



CONSTRUCTION NOTICE

PROJECT TITLE

Work on your street will begin within one week to replace the existing water mains servicing your community.

The work will consist of:

- Saw-cutting and trench work on Ingulf Street from Morena Boulevard to Galveston Street to install new water mains, water laterals and fire hydrants.
- Streets where trenching takes place will be resurfaced and curb ramps will be upgraded to facilitate access for persons with disabilities where required.
- This work is anticipated to be complete in your community by December 2016.

How your neighborhood may be impacted:

- Water service to some properties during construction will be provided by a two-inch highline pipe that will run along the curb. To report a highline leak call 619-515-3525.
- Temporary water service disruptions are planned. If planned disruptions impact your property, you will receive advance notice.
- Parking restrictions will exist because of the presence of construction equipment and materials.
- "No Parking" signs will be displayed 72 hours in advance of the work.
- Cars parked in violation of signs will be TOWED.

Hours and Days of Operation:

Monday through Friday X:XX AM to X:XX PM.

City of San Diego Contractor:

Company Name, XXX-XXX-XXXX



CONSTRUCTION NOTICE

PROJECT TITLE

Work on your street will begin within one week to replace the existing water mains servicing your community.

The work will consist of:

- Saw-cutting and trench work on Ingulf Street from Morena Boulevard to Galveston Street to install new water mains, water laterals and fire hydrants.
- Streets where trenching takes place will be resurfaced and curb ramps will be upgraded to facilitate access for persons with disabilities where required.
- This work is anticipated to be complete in your community by December 2016.

How your neighborhood may be impacted:

- Water service to some properties during construction will be provided by a two-inch highline pipe that will run along the curb. To report a highline leak call 619-515-3525.
- Temporary water service disruptions are planned. If planned disruptions impact your property, you will receive advance notice.
- Parking restrictions will exist because of the presence of construction equipment and materials.
- "No Parking" signs will be displayed 72 hours in advance of the work.
- Cars parked in violation of signs will be TOWED.

Hours and Days of Operation:

Monday through Friday X:XX AM to X:XX PM.

City of San Diego Contractor:

Company Name, XXX-XXX-XXXX

To contact the City of San Diego:  **Public Works**
619-533-4207 | engineering@sandiego.gov | sandiego.gov/CIP

Ⓢ This information is available in alternative formats upon request.

To contact the City of San Diego:  **Public Works**
619-533-4207 | engineering@sandiego.gov | sandiego.gov/CIP

Ⓢ This information is available in alternative formats upon request.

APPENDIX M

ADVANCED METERING INFRASTRUCTURE (AMI) DEVICE PROTECTION

Protecting AMI Devices in Meter Boxes and on Street Lights

The Public Utilities Department (PUD) has begun the installation of the Advanced Metering Infrastructure (AMI) technology as a new tool to enhance water meter reading accuracy and efficiency, customer service and billing, and to be used by individual accounts to better manage the efficient use of water. **All AMI devices shall be protected per Section 5-2, "Protection", of the 2015 Whitebook.**

AMI technology allows water meters to be read electronically rather than through direct visual inspection by PUD field staff. This will assist PUD staff and customers in managing unusual consumption patterns which could indicate leaks or meter tampering on a customer's property.

Three of the main components of an AMI system are the:

- A. Endpoints, see Photo 1:

Photo 1

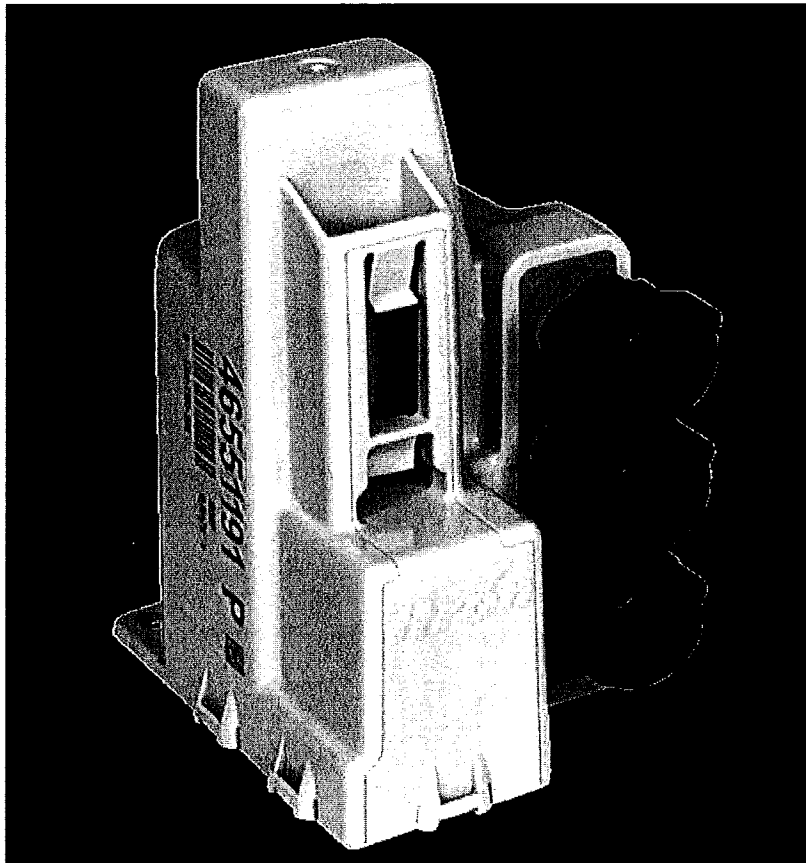

B. AMI Antenna attached to Endpoint (antenna not always required), see Photo 2:

Photo 2

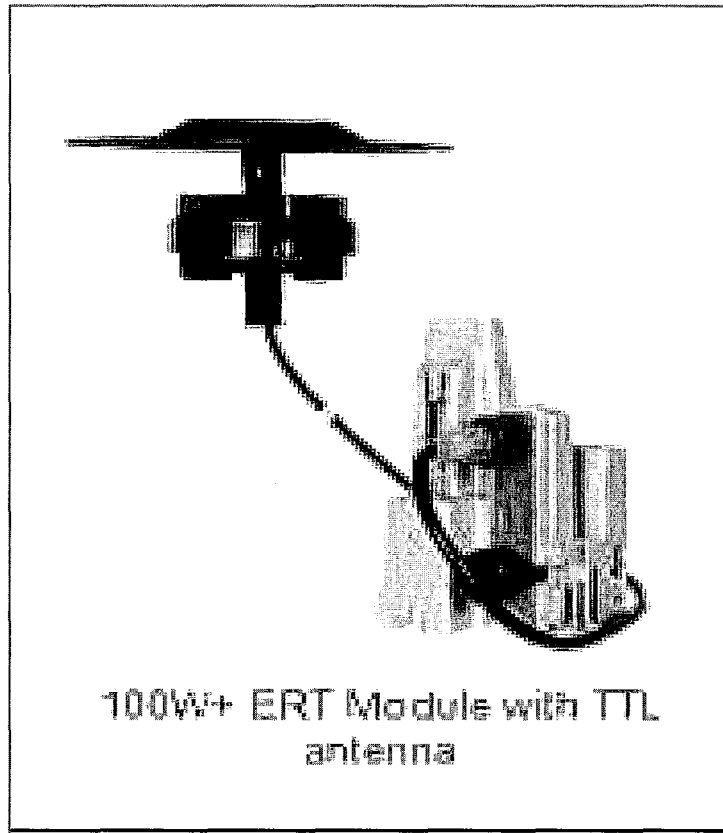

Network Devices, see Photo 3:

Photo 3

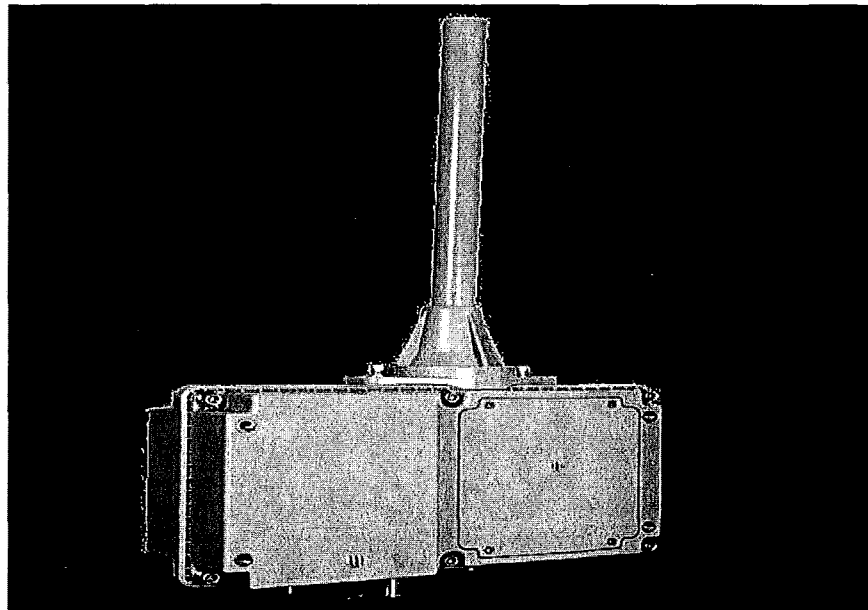

AMI endpoints transmit meter information to the AMI system and will soon be on the vast majority of meters in San Diego. These AMI devices provide interval consumption data to the PUD's Customer Support Division. If these devices are damaged or communication is interrupted, this Division will be alerted of the situation. The endpoints are installed in water meter boxes, coffins, and vaults adjacent to the meter. A separate flat round antenna may also be installed through the meter box lid. This antenna is connected to the endpoint via cable. The following proper installation shall be implemented when removing the lid to avoid damaging the antenna, cable, and/or endpoint. Photo 4 below demonstrates a diagram of the connection:

Photo 4

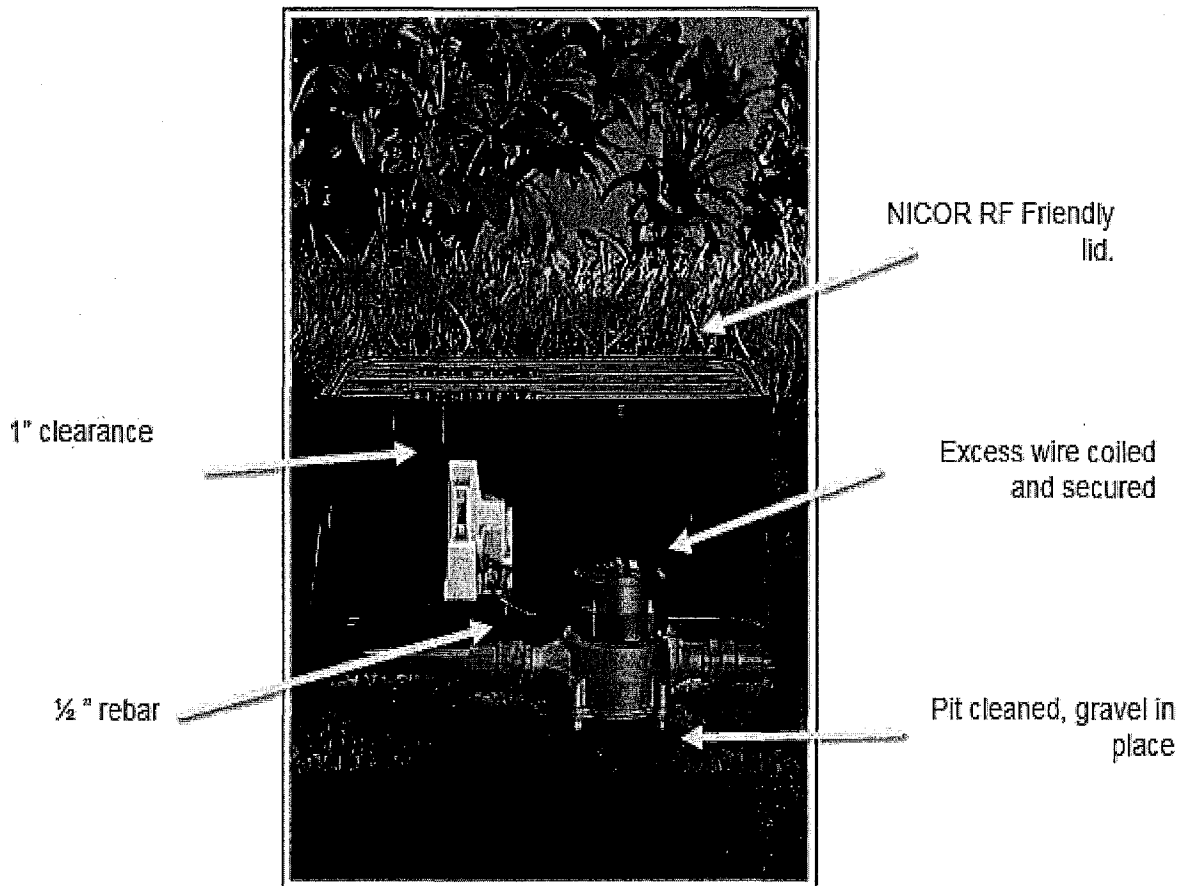

The AMI device ERT/Endpoint/Transmitter shall be positioned and installed as discussed in this Appendix. If the ERT/Endpoint/Transmitter is disturbed, it shall be re-installed and returned to its original installation with the end points pointed upwards as shown below in Photo 5.

The PUD's code compliance staff will issue citations and invoices to you for any damaged AMI devices that are not re-installed as discussed in the Contract Document

Photo 5 below shows a typical installation of an AMI endpoint on a water meter.

Photo 5

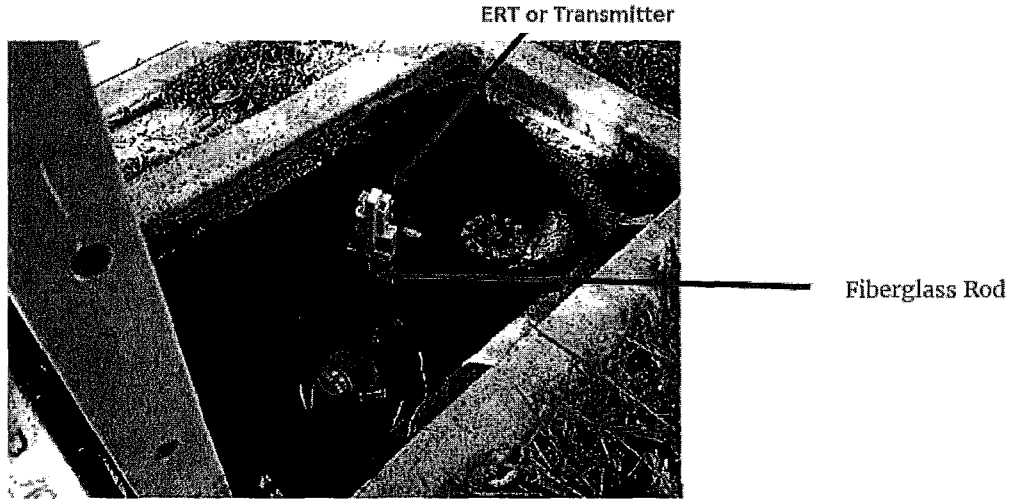
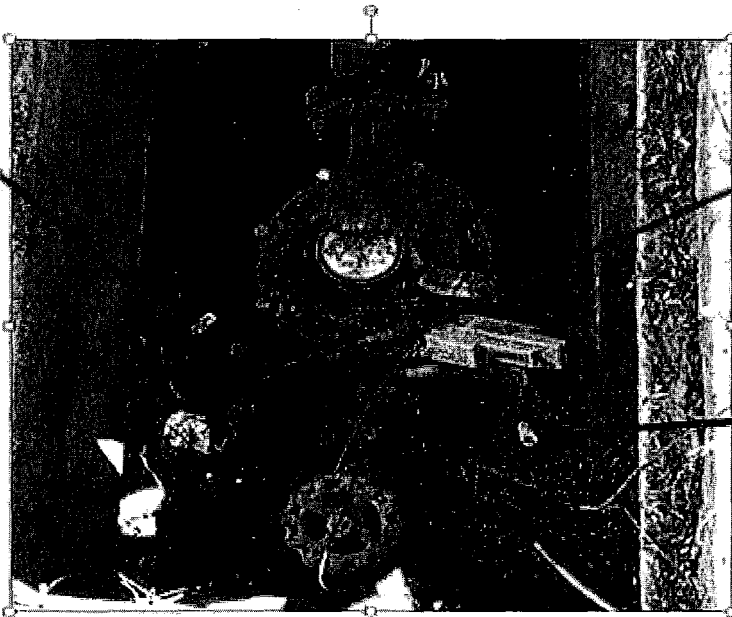

Photo 6 below is an example of disturbance that shall be avoided:

Photo 6

The antenna was drilled into the lid and now it is removed



You are responsible when working in and around meter boxes. If you encounter these endpoints, use proper care and do not disconnect them from the registers on top of the water meter. If the lid has an antenna drilled through, do not change or tamper with the lid and inform the Resident Engineer immediately about the location of that lid. Refer to Photo 7 below:

Photo 7



Another component of the AMI system are the Network Devices. The Network Devices are strategically placed units (mainly on street light poles) that collect interval meter reading data from multiple meters for transmission to the Department Control Computer. **If you come across any of these devices on street lights that will be removed or replaced (refer to Photos 8 and 9 below), notify AMI Project Manager Arwa Sayed at (619) 362-0121 immediately.**

Photo 8 shows an installed network device on a street light. On the back of each Network Device is a sticker with contact information. See Photo 9. **Call PUD Water Emergency Repairs at 619-515-3525 if your work will impact these street lights.** These are assets that belong to the City of San Diego and you shall be responsible for any costs of disruption of this network.

Photo 8

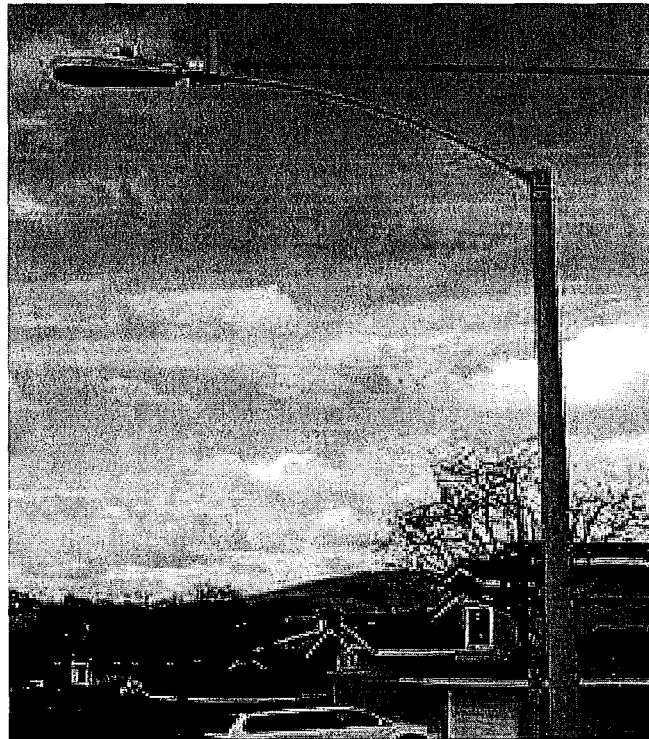

Network Device

Photo 9

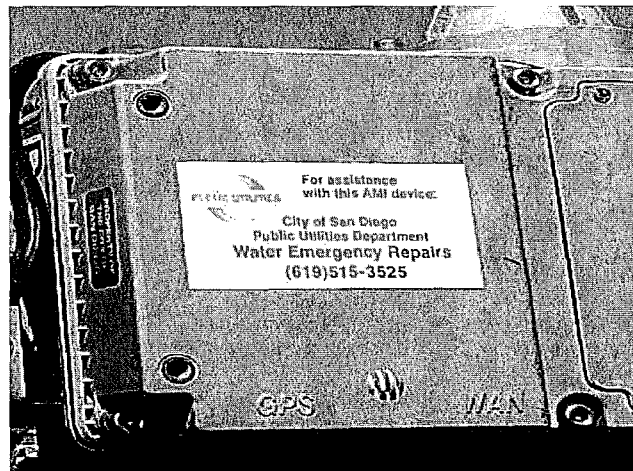

If you encounter any bad installations, disconnected/broken/buried endpoints, or inadvertently damage any AMI devices or cables, notify the Resident Engineer immediately. The Resident Engineer will then immediately contact the AMI Project Manager, Arwa Sayed, at (619) 362-0121.

APPENDIX N

LIST OF THE REPLUMBING

GJ 764 & 821

WBS: B-00368.02/ B-00413.02

	Property Address	Replumb Agreement	Backflow Preventer Device Agreement
1	3623 Fenelon Street San Diego, CA 92106	X	X
2	3617 Fenelon Street San Diego, CA 92106	X	X
3	3576 Emerson Street San Diego, CA 92106	X	
4	3566 Emerson Street San Diego, CA 92106	X	
5	3714 Cedarbrae Ln San Diego, CA 92106	X	X
6	3648 Cedarbrae Ln San Diego, CA 92106	X	X
7	3632 Cedarbrae Ln San Diego, CA 92106	X	X
8	3620 Cedarbrae Ln San Diego, CA 92106	X	X
9	955 Albion Street San Diego, CA 92106	X	
10	959 Albion Street San Diego, CA 92106	X	
11	549 Albion Street San Diego, CA 92106	X	X
12	570 Gage Drive San Diego, CA 92106	X	X
13	578 Gage Drive San Diego, CA 92106	X	X

ATTACHMENT F
INTENTIONALLY LEFT BLANK

ATTACHMENT G
CONTRACT AGREEMENT

CONTRACT AGREEMENT

CONSTRUCTION CONTRACT

This contract is made and entered into between THE CITY OF SAN DIEGO, a municipal corporation, herein called "City", and **TC Construction Corporation**, herein called "Contractor" for construction of **Sewer & AC Water GJ 764 & 821**; Bid No. **K-17-1544-DBB-3**; in the amount of **Eight Million, Seven Hundred Eighty-Five Thousand, Seven Hundred Seventy-Six and Twenty-Two Cents (\$8,785,776.22), which is comprised on the Base Bid alone.**

IN CONSIDERATION of the payments to be made hereunder and the mutual undertakings of the parties hereto, City and Contractor agree as follows:

1. The following are incorporated into this contract as though fully set forth herein:
 - (a) The attached Faithful Performance and Payment Bonds.
 - (b) The attached Proposal included in the Bid documents by the Contractor.
 - (c) Reference Standards listed in the Instruction to Bidders and the Supplementary Special Provisions (SSP).
 - (d) Phased Funding Schedule Agreement.
 - (e) That certain documents entitled **Sewer & AC Water GJ 764 & 821**, on file in the office of the Public Works Department as Document No. **B-15106, B-00368, B-15107, B-00413**, as well as all matters referenced therein.
2. The Contractor shall perform and be bound by all the terms and conditions of this contract and in strict conformity therewith shall perform and complete in a good and workmanlike manner **Sewer & AC Water GJ 764 & 821**, Bid Number **K-17-1544-DBB-3**, San Diego, California.
3. For such performances, the City shall pay to Contractor the amounts set forth at the times and in the manner and with such additions or deductions as are provided for in this contract, and the Contractor shall accept such payment in full satisfaction of all claims incident to such performances.
4. No claim or suit whatsoever shall be made or brought by Contractor against any officer, agent, or employee of the City for or on account of anything done or omitted to be done in connection with this contract, nor shall any such officer, agent, or employee be liable hereunder.
5. This contract is effective as of the date that the Mayor or designee signs the agreement.

CONTRACT AGREEMENT (continued)

IN WITNESS WHEREOF, this Agreement is signed by the City of San Diego, acting by and through its Mayor or designee, pursuant to Municipal Code **§22.3102** authorizing such execution.

THE CITY OF SAN DIEGO

APPROVED AS TO FORM

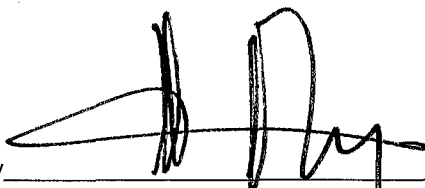
By 
Print Name: Albert P. Rejhany
Deputy Director
Public Works Department
Date: 6/21/17

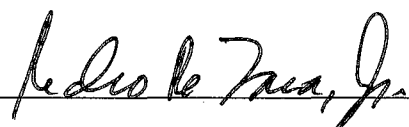
Mara W. Elliott, City Attorney
By 
Print Name: Pedro De Lara, Jr.
Deputy City Attorney
Date: 6/27/17

CONTRACTOR

By 
Print Name: AUSTIN CAMERON
Title: PRESIDENT
Date: 5/31/17

City of San Diego License No.: B1987004 773

State Contractor's License No. 402459

DEPARTMENT OF INDUSTRIAL RELATIONS (DIR) REGISTRATION NUMBER: 100003132

CERTIFICATIONS AND FORMS

The Bidder, by submitting its electronic bid, agrees to and certifies under penalty of perjury under the laws of the State of California, that the certifications, forms and affidavits submitted as part of this bid are true and correct.

Bidder's General Information

To the City of San Diego:

Pursuant to "Notice Inviting Bids", specifications, and requirements on file with the City Clerk, and subject to all provisions of the Charter and Ordinances of the City of San Diego and applicable laws and regulations of the United States and the State of California, the undersigned hereby proposes to furnish to the City of San Diego, complete at the prices stated herein, the items or services hereinafter mentioned. The undersigned further warrants that this bid is not made in the interest of, or on behalf of, any undisclosed person, partnership, company, association, organization, or corporation; that the bid is genuine and not collusive or sham; that the bidder has not directly or indirectly induced or solicited any other bidder to put in a false or sham bid, and has not directly or indirectly colluded, conspired, connived, or agreed with any bidder or anyone else to put in a sham bid, or that anyone shall refrain from bidding; that the bidder has not in any manner, directly or indirectly, sought by agreement, communication, or conference with anyone to fix the bid price of the bidder or any other bidder, or to fix any overhead, profit, or cost element of the bid price, or of that of any other bidder, or to secure any advantage against the public body awarding the contract of anyone interested in the proposed contract; that all statements contained in the bid are true; and, further, that the bidder has not, directly or indirectly, submitted his or her bid price or any breakdown thereof, or the contents thereof, or divulged information or data relative thereto, or paid, and will not pay, any fee to any corporation, partnership, company, association, organization, bid depository, or to any member or agent thereof to effectuate a collusive or sham bid.

The undersigned bidder(s) further warrants that bidder(s) has thoroughly examined and understands the entire Contract Documents (plans and specifications) and the Bidding Documents therefore, and that by submitting said Bidding Documents as its bid proposal, bidder(s) acknowledges and is bound by the entire Contract Documents, including any addenda issued thereto, as such Contract Documents incorporated by reference in the Bidding Documents.

**NON-COLLUSION AFFIDAVIT TO BE EXECUTED BY BIDDER AND SUBMITTED WITH BID
UNDER 23 UNITED STATES CODE 112 AND PUBLIC CONTRACT CODE 7106**

State of California

County of San Diego

The bidder, being first duly sworn, deposes and says that he or she is authorized by the party making the foregoing bid that the bid is not made in the interest of, or on behalf of, any undisclosed person, partnership, company, association, organization, or corporation; that the bid is genuine and not collusive or sham; that the bidder has not directly or indirectly induced or solicited any other bidder to put in a false or sham bid, and has not directly or indirectly colluded, conspired, connived, or agreed with any bidder or anyone else to put in a sham bid, or that anyone shall refrain from bidding; that the bidder has not in any manner, directly or indirectly, sought by agreement, communication, or conference with anyone to fix the bid price of the bidder or any other bidder, or to fix any overhead, profit, or cost element of the bid price, or of that of any other bidder, or to secure any advantage against the public body awarding the contract of anyone interested in the proposed contract; that all statements contained in the bid are true; and further, that the bidder has not, directly or indirectly, submitted his or her bid price or any breakdown thereof, or the contents thereof, or divulged information or data relative thereto, or paid, and will not pay, any fee to any corporation, partnership, company, association, organization, bid depository, or to any member or agent thereof to effectuate a collusive or sham bid.

CONTRACTOR CERTIFICATION

DRUG-FREE WORKPLACE

I hereby certify that I am familiar with the requirements of San Diego City Council Policy No. 100-17 regarding Drug-Free Workplace as outlined in the WHITEBOOK, Section 7-13.3, "Drug-Free Workplace", of the project specifications, and that;

This company has in place a drug-free workplace program that complies with said policy. I further certify that each subcontract agreement for this project contains language which indicates the subcontractor's agreement to abide by the provisions of subdivisions a) through c) of the policy as outlined.

CONTRACTOR CERTIFICATION

AMERICAN WITH DISABILITIES ACT (ADA) COMPLIANCE CERTIFICATION

I hereby certify that I am familiar with the requirements of San Diego City Council Policy No. 100-4 regarding the American With Disabilities Act (ADA) outlined in the WHITEBOOK, Section 7-13.2, "American With Disabilities Act", of the project specifications, and that:

This company has in place workplace program that complies with said policy. I further certify that each subcontract agreement for this project contains language which indicates the subcontractor's agreement to abide by the provisions of the policy as outlined.

CONTRACTOR CERTIFICATION

CONTRACTOR STANDARDS – PLEDGE OF COMPLIANCE

I declare under penalty of perjury that I am authorized to make this certification on behalf of the company submitting this bid/proposal, that as Contractor, I am familiar with the requirements of City of San Diego Municipal Code § 22.3004 regarding Contractor Standards as outlined in the WHITEBOOK, Section 7-13.4, ("Contractor Standards"), of the project specifications, and that Contractor has complied with those requirements.

I further certify that each of the Contractor's subcontractors whose subcontracts are greater than \$50,000 in value has completed a Pledge of Compliance attesting under penalty of perjury of having complied with City of San Diego Municipal Code § 22.3004.

AFFIDAVIT OF DISPOSAL

(To be submitted upon completion of Construction pursuant to the contracts Certificate of Completion)

WHEREAS, on the _____ DAY OF _____, 2____ the undersigned entered into and executed a contract with the City of San Diego, a municipal corporation, for:

(Name of Project or Task)

as particularly described in said contract and identified as Bid No. **K-17-1544-DBB-3**; SAP No. (WBS/IO/CC); **B-15106, B-00368, B-15107, B-00413**; and **WHEREAS**, the specification of said contract requires the Contractor to affirm that "all brush, trash, debris, and surplus materials resulting from this project have been disposed of in a legal manner"; and **WHEREAS**, said contract has been completed and all surplus materials disposed of:

NOW, THEREFORE, in consideration of the final payment by the City of San Diego to said Contractor under the terms of said contract, the undersigned Contractor, does hereby affirm that all surplus materials as described in said contract have been disposed of at the following location(s)

and that they have been disposed of according to all applicable laws and regulations.

Dated this _____ DAY OF _____, _____.

By: _____
Contractor

ATTEST:

State of _____ County of _____

On this _____ DAY OF _____, 2____, before the undersigned, a Notary Public in and for said County and State, duly commissioned and sworn, personally appeared _____ known to me to be the _____ Contractor named in the foregoing Release, and whose name is subscribed thereto, and acknowledged to me that said Contractor executed the said Release.

Notary Public in and for said County and State

CONTRACTOR CERTIFICATION

Equal Benefits Ordinance Certification

I declare under penalty of perjury that I am familiar with the requirements of and in compliance with the City of San Diego Municipal Code § 22.4300 regarding Equal Benefits Ordinance.

LIST OF SUBCONTRACTORS

***** PROVIDED FOR ILLUSTRATIVE PURPOSES ONLY *** TO BE SUBMITTED IN ELECTRONIC FORMAT ONLY *** SEE INSTRUCTIONS TO BIDDERS, FOR FURTHER INFORMATION**

In accordance with the requirements of the "Subletting and Subcontracting Fair Practices Act", Section 4100, of the California Public Contract Code (PCC), the Bidder is to list below the name, address and license number of each Subcontractor who will perform work, labor, render services or specially fabricate and install a portion [type] of the work or improvement, in an amount of or in excess of 0.5% of the Contractor's total Bid. Failure to comply with this requirement may result in the Bid being rejected as non-responsive. The Contractor is to list only one Subcontractor for each portion of the Work. The Bidder's attention is directed to the Special Provisions - General; Paragraph 2-3 Subcontracts, which stipulates the percentage of the Work to be performed with the Bidder's own forces. The Bidder is to also list all SLBE, ELBE, DBE, DVBE, MBE, WBE, OBE, SDB, WoSB, HUBZone, and SDVOSB Subcontractors for which the Bidders are seeking recognition towards achieving any mandatory, voluntary, or both subcontracting participation percentages.

NAME, ADDRESS AND TELEPHONE NUMBER OF SUBCONTRACTOR	CONSTRUCTOR OR DESIGNER	SUBCONTRACTOR LICENSE NUMBER	TYPE OF WORK	DOLLAR VALUE OF SUBCONTRACT	MBE, WBE, DBE, DVBE, OBE, ELBE, SLBE, SDB, WoSB, HUBZone, OR SDVOSB	WHERE CERTIFIED	CHECK IF JOINT VENTURE PARTNERSHIP
Name: _____ Address: _____ City: _____ State: _____ Zip: _____ Phone: _____ Email: _____							
Name: _____ Address: _____ City: _____ State: _____ Zip: _____ Phone: _____ Email: _____							

- ① As appropriate, Bidder shall identify Subcontractor as one of the following and shall include a valid proof of certification (except for OBE, SLBE and ELBE):
- | | | | |
|---|--------|--|---------|
| Certified Minority Business Enterprise | MBE | Certified Woman Business Enterprise | WBE |
| Certified Disadvantaged Business Enterprise | DBE | Certified Disabled Veteran Business Enterprise | DVBE |
| Other Business Enterprise | OBE | Certified Emerging Local Business Enterprise | ELBE |
| Certified Small Local Business Enterprise | SLBE | Small Disadvantaged Business | SDB |
| Woman-Owned Small Business | WoSB | HUBZone Business | HUBZone |
| Service-Disabled Veteran Owned Small Business | SDVOSB | | |
- ② As appropriate, Bidder shall indicate if Subcontractor is certified by:
- | | | | |
|--|--------|--|----------|
| City of San Diego | CITY | State of California Department of Transportation | CALTRANS |
| California Public Utilities Commission | CPUC | | |
| State of California's Department of General Services | CADoGS | City of Los Angeles | LA |
| State of California | CA | U.S. Small Business Administration | SBA |

The Bidder will not receive any subcontracting participation percentages if the Bidder fails to submit the required proof of certification.

NAMED EQUIPMENT/MATERIAL SUPPLIER LIST

*** PROVIDED FOR ILLUSTRATIVE PURPOSES ONLY *** TO BE SUBMITTED IN ELECTRONIC FORMAT ONLY *** SEE INSTRUCTIONS TO BIDDERS FOR FURTHER INFORMATION

NAME, ADDRESS AND TELEPHONE NUMBER OF VENDOR/SUPPLIER	MATERIALS OR SUPPLIES	DOLLAR VALUE OF MATERIAL OR SUPPLIES	SUPPLIER (Yes/No)	MANUFACTURER (Yes/No)	MBE, WBE, DBE, DVBE, OBE, ELBE, SLBE, SDB, WoSB, HUBZone, OR SDVOSB①	WHERE CERTIFIED②
Name: _____ Address: _____ City: _____ State: _____ Zip: _____ Phone: _____ Email: _____						
Name: _____ Address: _____ City: _____ State: _____ Zip: _____ Phone: _____ Email: _____						

- ① As appropriate, Bidder shall identify Vendor/Supplier as one of the following and shall include a valid proof of certification (except for OBE,SLBE and ELBE):
- | | | | |
|---|--------|--|---------|
| Certified Minority Business Enterprise | MBE | Certified Woman Business Enterprise | WBE |
| Certified Disadvantaged Business Enterprise | DBE | Certified Disabled Veteran Business Enterprise | DVBE |
| Other Business Enterprise | OBE | Certified Emerging Local Business Enterprise | ELBE |
| Certified Small Local Business Enterprise | SLBE | Small Disadvantaged Business | SDB |
| Woman-Owned Small Business | WoSB | HUBZone Business | HUBZone |
| Service-Disabled Veteran Owned Small Business | SDVOSB | | |
- ② As appropriate, Bidder shall indicate if Vendor/Supplier is certified by:
- | | | | |
|--|--------|--|----------|
| City of San Diego | CITY | State of California Department of Transportation | CALTRANS |
| California Public Utilities Commission | CPUC | | |
| State of California's Department of General Services | CADoGS | City of Los Angeles | LA |
| State of California | CA | U.S. Small Business Administration | SBA |

The Bidder will not receive any subcontracting participation percentages if the Bidder fails to submit the required proof of certification.

SUBCONTRACTORS ADDITIVE/DEDUCTIVE ALTERNATE (USE ONLY WHEN ADDITIVE ALTERNATES ARE REQUIRED)

***** PROVIDED FOR ILLUSTRATIVE PURPOSES ONLY *** TO BE SUBMITTED IN ELECTRONIC FORMAT ONLY *** SEE INSTRUCTIONS TO BIDDERS, FOR FURTHER INFORMATION**

ADDITIVE/ DEDUCTIVE ALTERNATE	NAME, ADDRESS AND TELEPHONE NUMBER OF SUBCONTRACTOR	CONSTRUCTOR OR DESIGNER	SUBCONTRACT OR LICENSE NUMBER	TYPE OF WORK	DOLLAR VALUE OF SUBCONTRACT	MBE, WBE, DBE, DVBE, OBE, ELBE, SLBE, SDB, WoSB, HUBZone, OR SDVOSB	WHERE CERTIFIED	CHECK IF JOINT VENTURE PARTNERSHIP
	Name: _____ Address: _____ City: _____ State: _____ Zip: _____ Phone: _____ Email: _____							
	Name: _____ Address: _____ City: _____ State: _____ Zip: _____ Phone: _____ Email: _____							

① As appropriate, Bidder shall identify Subcontractor as one of the following and shall include a valid proof of certification (except for OBE, SLBE and ELBE):

Certified Minority Business Enterprise	MBE	Certified Woman Business Enterprise	WBE
Certified Disadvantaged Business Enterprise	DBE	Certified Disabled Veteran Business Enterprise	DVBE
Other Business Enterprise	OBE	Certified Emerging Local Business Enterprise	ELBE
Certified Small Local Business Enterprise	SLBE	Small Disadvantaged Business	SDB
Woman-Owned Small Business	WoSB	HUBZone Business	HUBZone
Service-Disabled Veteran Owned Small Business	SDVOSB		

② As appropriate, Bidder shall indicate if Subcontractor is certified by:

City of San Diego	CITY	State of California Department of Transportation	CALTRANS
California Public Utilities Commission	CPUC	State of California's Department of General Services	CADoGS
City of Los Angeles	LA	State of California	CA
U.S. Small Business Administration	SBA		

The Bidder will not receive any subcontracting participation percentages if the Bidder fails to submit the required proof of certification.

ELECTRONICALLY SUBMITTED FORMS

THE FOLLOWING FORMS MUST BE SUBMITTED IN PDF FORMAT WITH BID SUBMISSION

The following forms are to be completed by the bidder and submitted (uploaded) electronically with the bid in PlanetBids.

- A. BID BOND – See Instructions to Bidders, Bidders Guarantee of Good Faith (Bid Security) for further instructions**

- B. CONTRACTOR’S CERTIFICATION OF PENDING ACTIONS**

Bids will not be accepted until ALL the above-named forms are submitted as part of the bid submittal

BID BOND

**See Instructions to Bidders, Bidder Guarantee of Good Faith
(Bid Security)**

KNOW ALL MEN BY THESE PRESENTS,

That TC Construction Company, Inc. as Principal, and
Liberty Mutual Insurance Company as Surety, are

held and firmly bound unto The City of San Diego hereinafter called "OWNER," in the sum of **10% OF THE TOTAL BID AMOUNT** for the payment of which sum, well and truly to be made, we bind ourselves, our heirs, executors, administrators, successors, and assigns, jointly and severally, firmly by these presents.

WHEREAS, said Principal has submitted a Bid to said OWNER to perform the WORK required under the bidding schedule(s) of the OWNER's Contract Documents entitled

Sewer & AC Water GJ 764 & 821; Invitation/Bid No. K-17-1544-DBB-3

NOW THEREFORE, if said Principal is awarded a contract by said OWNER and, within the time and in the manner required in the "Notice Inviting Bids" enters into a written Agreement on the form of agreement bound with said Contract Documents, furnishes the required certificates of insurance, and furnishes the required Performance Bond and Payment Bond, then this obligation shall be null and void, otherwise it shall remain in full force and effect. In the event suit is brought upon this bond by said OWNER and OWNER prevails, said Surety shall pay all costs incurred by said OWNER in such suit, including a reasonable attorney's fee to be fixed by the court.

SIGNED AND SEALED, this 13th day of April, 2017

TC Construction Company, Inc. (SEAL)

Liberty Mutual Insurance Company (SEAL)

(Principal)

(Surety)

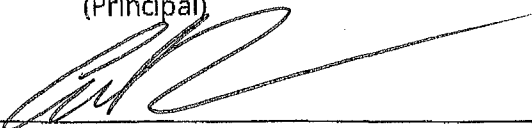
By: 

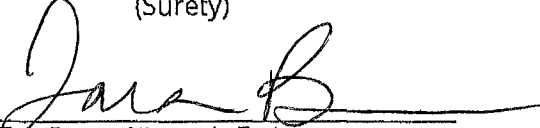
By: 

(Signature)

Tara Bacon, Attorney-in-Fact
(Signature)

(SEAL AND NOTARIAL ACKNOWLEDGEMENT OF SURETY)

CALIFORNIA ALL-PURPOSE ACKNOWLEDGMENT

CIVIL CODE § 1189

A notary public or other officer completing this certificate verifies only the identity of the individual who signed the document to which this certificate is attached, and not the truthfulness, accuracy, or validity of that document.

State of California)
County of San Diego)
On April 17, 2017 before me, Sandra Weeks, Notary Public
Date Here Insert Name and Title of the Officer
personally appeared Austin Cameron
Name(s) of Signer(s)

who proved to me on the basis of satisfactory evidence to be the person(s) whose name(s) is/are subscribed to the within instrument and acknowledged to me that he/she/they executed the same in his/her/their authorized capacity(ies), and that by his/her/their signature(s) on the instrument the person(s), or the entity upon behalf of which the person(s) acted, executed the instrument.

I certify under PENALTY OF PERJURY under the laws of the State of California that the foregoing paragraph is true and correct.

WITNESS my hand and official seal.

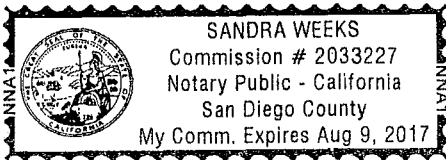

Signature Sandra Weeks
Signature of Notary Public

Place Notary Seal Above

OPTIONAL

Though this section is optional, completing this information can deter alteration of the document or fraudulent reattachment of this form to an unintended document.

Description of Attached Document

Title or Type of Document: Bid Bond Document Date: _____
Number of Pages: 1 Signer(s) Other Than Named Above: N/A

Capacity(ies) Claimed by Signer(s)

Signer's Name: Austin Cameron
 Corporate Officer — Title(s): President
 Partner — Limited General
 Individual Attorney in Fact
 Trustee Guardian or Conservator
 Other: _____

Signer's Name: _____
 Corporate Officer — Title(s): _____
 Partner — Limited General
 Individual Attorney in Fact
 Trustee Guardian or Conservator
 Other: _____

Signer Is Representing: TC Construction Co, Inc.

CALIFORNIA ALL-PURPOSE ACKNOWLEDGMENT
CIVIL CODE § 1189

A notary public or other officer completing this certificate verifies only the identity of the individual who signed the document to which this certificate is attached, and not the truthfulness, accuracy, or validity of that document.

State of California
County of San Diego)

On April 13, 2017 before me, Diana Kai Murphy, Notary Public
(insert name and title of the officer)

personally appeared Tara Bacon,
who proved to me on the basis of satisfactory evidence to be the person(s) whose name(s) is/are subscribed to the within instrument and acknowledged to me that he/she/they executed the same in his/her/their authorized capacity(ies), and that by his/her/their signature(s) on the instrument the person(s), or the entity upon behalf of which the person(s) acted, executed the instrument.

I certify under PENALTY OF PERJURY under the laws of the State of California that the foregoing paragraph is true and correct.

WITNESS my hand and official seal.

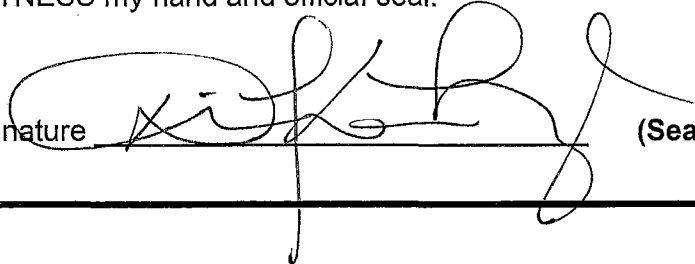
Signature  (Seal)



THIS POWER OF ATTORNEY IS NOT VALID UNLESS IT IS PRINTED ON RED BACKGROUND.

This Power of Attorney limits the acts of those named herein, and they have no authority to bind the Company except in the manner and to the extent herein stated.

Certificate No. 7552261

Liberty Mutual Insurance Company
The Ohio Casualty Insurance Company West American Insurance Company

POWER OF ATTORNEY

KNOWN ALL PERSONS BY THESE PRESENTS: That The Ohio Casualty Insurance Company is a corporation duly organized under the laws of the State of New Hampshire, that Liberty Mutual Insurance Company is a corporation duly organized under the laws of the State of Massachusetts, and West American Insurance Company is a corporation duly organized under the laws of the State of Indiana (herein collectively called the "Companies"), pursuant to and by authority herein set forth, does hereby name, constitute and appoint, Bradley R. Orr; Dale G. Harshaw; Geoffrey Shelton; John R. Qualin; Kyle King; Minna Huovila; Tara Bacon

all of the city of San Diego, state of CA each individually if there be more than one named, its true and lawful attorney-in-fact to make, execute, seal, acknowledge and deliver, for and on its behalf as surely and as its act and deed, any and all undertakings, bonds, recognizances and other surety obligations, in pursuance of these presents and shall be as binding upon the Companies as if they have been duly signed by the president and attested by the secretary of the Companies in their own proper persons.

IN WITNESS WHEREOF, this Power of Attorney has been subscribed by an authorized officer or official of the Companies and the corporate seals of the Companies have been affixed thereto this 22nd day of November, 2016.



The Ohio Casualty Insurance Company
Liberty Mutual Insurance Company
West American Insurance Company

By: David M. Carey
David M. Carey, Assistant Secretary

STATE OF PENNSYLVANIA ss
COUNTY OF MONTGOMERY

On this 22nd day of November, 2016, before me personally appeared David M. Carey, who acknowledged himself to be the Assistant Secretary of Liberty Mutual Insurance Company, The Ohio Casualty Company, and West American Insurance Company, and that he, as such, being authorized so to do, execute the foregoing instrument for the purposes therein contained by signing on behalf of the corporations by himself as a duly authorized officer.

IN WITNESS WHEREOF, I have hereunto subscribed my name and affixed my notarial seal at King of Prussia, Pennsylvania, on the day and year first above written.



COMMONWEALTH OF PENNSYLVANIA
Notarial Seal
Teresa Pastella, Notary Public
Upper Merion Twp., Montgomery County
My Commission Expires March 28, 2017
Member, Pennsylvania Association of Notaries

By: Teresa Pastella
Teresa Pastella, Notary Public

This Power of Attorney is made and executed pursuant to and by authority of the following By-laws and Authorizations of The Ohio Casualty Insurance Company, Liberty Mutual Insurance Company, and West American Insurance Company which resolutions are now in full force and effect reading as follows:

ARTICLE IV – OFFICERS – Section 12. Power of Attorney. Any officer or other official of the Corporation authorized for that purpose in writing by the Chairman or the President, and subject to such limitation as the Chairman or the President may prescribe, shall appoint such attorneys-in-fact, as may be necessary to act in behalf of the Corporation to make, execute, seal, acknowledge and deliver as surety any and all undertakings, bonds, recognizances and other surety obligations. Such attorneys-in-fact, subject to the limitations set forth in their respective powers of attorney, shall have full power to bind the Corporation by their signature and execution of any such instruments and to attach thereto the seal of the Corporation. When so executed, such instruments shall be as binding as if signed by the President and attested to by the Secretary. Any power or authority granted to any representative or attorney-in-fact under the provisions of this article may be revoked at any time by the Board, the Chairman, the President or by the officer or officers granting such power or authority.

ARTICLE XIII – Execution of Contracts – SECTION 5. Surety Bonds and Undertakings. Any officer of the Company authorized for that purpose in writing by the chairman or the president, and subject to such limitations as the chairman or the president may prescribe, shall appoint such attorneys-in-fact, as may be necessary to act in behalf of the Company to make, execute, seal, acknowledge and deliver as surety any and all undertakings, bonds, recognizances and other surety obligations. Such attorneys-in-fact subject to the limitations set forth in their respective powers of attorney, shall have full power to bind the Company by their signature and execution of any such instruments and to attach thereto the seal of the Company. When so executed such instruments shall be as binding as if signed by the president and attested by the secretary.

Certificate of Designation – The President of the Company, acting pursuant to the Bylaws of the Company, authorizes David M. Carey, Assistant Secretary to appoint such attorneys-in-fact as may be necessary to act on behalf of the Company to make, execute, seal, acknowledge and deliver as surety any and all undertakings, bonds, recognizances and other surety obligations.

Authorization – By unanimous consent of the Company's Board of Directors, the Company consents that facsimile or mechanically reproduced signature of any assistant secretary of the Company, wherever appearing upon a certified copy of any power of attorney issued by the Company in connection with surety bonds, shall be valid and binding upon the Company with the same force and effect as though manually affixed.

I, Renee C. Llewellyn, the undersigned, Assistant Secretary, The Ohio Casualty Insurance Company, Liberty Mutual Insurance Company, and West American Insurance Company do hereby certify that the original power of attorney of which the foregoing is a full, true and correct copy of the Power of Attorney executed by said Companies, is in full force and effect and has not been revoked.

IN TESTIMONY WHEREOF, I have hereunto set my hand and affixed the seals of said Companies this 13th day of April, 2017.



By: Renee C. Llewellyn
Renee C. Llewellyn, Assistant Secretary

Not valid for mortgage, note, loan, letter of credit, currency rate, interest rate or residual value guarantees.

To confirm the validity of this Power of Attorney call 1-610-832-8240 between 9:00 am and 4:30 pm EST on any business day.

CONTRACTOR'S CERTIFICATION OF PENDING ACTIONS

As part of its bid or proposal (Non-Price Proposal in the case of Design-Build contracts), the Bidder shall provide to the City a list of all instances within the past 10 years where a complaint was filed or pending against the Bidder in a legal or administrative proceeding alleging that Bidder discriminated against its employees, subcontractors, vendors or suppliers, and a description of the status or resolution of that complaint, including any remedial action taken.

CHECK ONE BOX ONLY.

- The undersigned certifies that within the past 10 years the Bidder has NOT been the subject of a complaint or pending action in a legal administrative proceeding alleging that Bidder discriminated against its employees, subcontractors, vendors or suppliers.

- The undersigned certifies that within the past 10 years the Bidder has been the subject of a complaint or pending action in a legal administrative proceeding alleging that Bidder discriminated against its employees, subcontractors, vendors or suppliers. A description of the status or resolution of that complaint, including any remedial action taken and the applicable dates is as follows:

DATE OF CLAIM	LOCATION	DESCRIPTION OF CLAIM	LITIGATION (Y/N)	STATUS	RESOLUTION/REMEDIAL ACTION TAKEN

Contractor Name: T C Construction Company Inc

Certified By Austin Cameron Title President

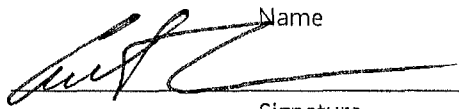
 Name _____
 Signature _____

Date 4-25-17

USE ADDITIONAL FORMS AS NECESSARY

Bid Results

Bidder Details

Prime Self Performance of
72.19%

Vendor Name TC Construction Company, Inc.
Address 10540 Prospect Avenue
 Santee, CA 92071
 United States

Respondee Austin Cameron
Respondee Title President
Phone 619-448-4560 Ext. 117
Email acameron@tcincsd.com
Vendor Type CAU,MALE,PQUAL,CADIR,Local
License # 402459
CADIR 1000003132

Bid Detail

Bid Format Electronic
Submitted May 5, 2017 1:59:18 PM (Pacific)
Delivery Method
Bid Responsive
Bid Status Submitted
Confirmation # 103896
Ranking 0

Respondee Comment

Buyer Comment

Attachments

File Title	File Name	File Type
Contractors Certification of Pending Actions	Contractors Certification of Pending Actions.pdf	Contractor's Certification of Pending Actions
Subcontractors Additive Deductive	K-17-1544-DBB-3_Subcontractors Additive_Deductive Alternate.pdf	Subcontractors Additive/Deductive Alternate Forms
Bid Bond	Bid Bond.pdf	Bid Bond

Line Items

Type	Item Code	UOM	Qty	Unit Price	Line Total	Comment
Main Bid GJ 764						
1	Bonds (Payment and Performance)					
	524126	LS	1	\$30,000.00	\$30,000.00	
2	Remote Control Camera Inspection (EOC Type II)					
	334290	AL	1	\$19,096.00	\$19,096.00	
3	Archaeological and Native American Monitoring Program					
	541690	LF	12308	\$5.00	\$61,540.00	
4	Paleontological Monitoring Program					
	541690	LF	3131	\$7.00	\$21,917.00	

Bid Results

Type	Item Code	UOM	Qty	Unit Price	Line Total	Comment
5	Archaeological and Native American Mitigation and Curation (EOC Type I)					
	541690	AL	1	\$15,000.00	\$15,000.00	
6	Paleontological Mitigation and Excavation					
	541690	CY	1800	\$4.50	\$8,100.00	
7	Suspension of Work - Resources					
	541690	DAYS	5	\$250.00	\$1,250.00	
8	Sewage Bypass and Pumping Plan (Diversion Plan)					
	237110	LS	1	\$2,500.00	\$2,500.00	
9	WPCP Development					
	541330	LS	1	\$3,500.00	\$3,500.00	
10	WPCP Implementation					
	237110	LS	1	\$60,000.00	\$60,000.00	
11	Video Recording of Existing Conditions					
	238990	LS	1	\$6,000.00	\$6,000.00	
12	Mobilization					
	237110	LS	1	\$150,000.00	\$150,000.00	
13	Field Orders (EOC Type II)					
		AL	1	\$250,000.00	\$250,000.00	
14	Additional Pavement Removal and Disposal					
	237310	CY	100	\$160.00	\$16,000.00	
15	Adjust Existing Manhole Frame and Cover to Grade					
	237310	EA	31	\$300.00	\$9,300.00	
16	Adjust Existing Gate Valve Frame and Cover to Grade					
	237310	EA	55	\$250.00	\$13,750.00	
17	Adjust Survey Monument to Grade					
	237310	EA	1	\$2,000.00	\$2,000.00	
18	Cold Mill AC Pavement (>1-1/2 Inch - 3 Inch)					
	237310	SF	99350	\$0.50	\$49,675.00	
19	Rubber Polymer Modified Slurry (RPMS) Type I Over Type II and Striping					
	237310	SF	103479	\$0.41	\$42,426.39	
20	Pavement Restoration Adjacent to Trench					
	237310	SF	12000	\$5.00	\$60,000.00	

Bid Results

Type	Item Code	UOM	Qty	Unit Price	Line Total	Comment
21	Asphalt Concrete Overlay and Striping					
	237310	TON	3000	\$116.00	\$348,000.00	
22	Pavement Fabric					
	237310	SF	155000	\$0.35	\$54,250.00	
23	Crack Seal					
	237310	LB	100	\$20.00	\$2,000.00	
24	Additional Curb & Gutter Removal and Replacement					
	237310	LF	100	\$65.00	\$6,500.00	
25	Alley Apron					
	237310	SF	1200	\$18.00	\$21,600.00	
26	Curb Ramp (Type A) with Detectable Warning Tiles					
	237310	EA	2	\$2,900.00	\$5,800.00	
27	Curb Ramp (Type B) with Detectable Warning Tiles					
	237310	EA	1	\$2,900.00	\$2,900.00	
28	Curb Ramp (Type C1) with Detectable Warning Tiles					
	237310	EA	7	\$3,400.00	\$23,800.00	
29	Curb Ramp (Type C2) with Detectable Warning Tiles					
	237310	EA	2	\$3,400.00	\$6,800.00	
30	Additional Sidewalk					
	237310	SF	100	\$13.00	\$1,300.00	
31	Abandon Existing Manhole Outside of Trench Limit					
	237110	EA	4	\$500.00	\$2,000.00	
32	Removal or Abandonment of Existing Water Facilities					
	237110	LF	3180	\$2.00	\$6,360.00	
33	Abandon and Fill Existing Sewer Main (8 Inch) Outside of the Trench Limit					
	237110	LF	1134	\$10.00	\$11,340.00	
34	Handling and Disposal of Non-friable Asbestos Material					
	237110	LF	4100	\$11.00	\$45,100.00	
35	Additional Bedding					
	237110	CY	300	\$60.00	\$18,000.00	
36	Water Main (8 Inch)					
	237110	LF	5104	\$94.00	\$479,776.00	

Bid Results

Type	Item Code	UOM	Qty	Unit Price	Line Total	Comment
37	Water Main (8 Inch, DR-14)					
	237110	LF	975	\$110.00	\$107,250.00	
38	Water Main (12 Inch)					
	237110	LF	1310	\$110.00	\$144,100.00	
39	Sewer Main (8 Inch)					
	237110	LF	2329	\$135.00	\$314,415.00	
40	Sewer Main (8 Inch, SDR-26)					
	237110	LF	2585	\$204.00	\$527,340.00	
41	Trench Shoring					
	237110	LS	1	\$27,000.00	\$27,000.00	
42	Gate Valve (8 Inch)					
	237110	EA	20	\$1,600.00	\$32,000.00	
43	Gate Valve (12 Inch)					
	237110	EA	6	\$3,000.00	\$18,000.00	
44	Fire Hydrant Assembly and Marker (6 Inch) 2 Ports					
	237110	EA	19	\$6,800.00	\$129,200.00	
45	Fire Service Connection (4 Inch)					
	237110	EA	1	\$3,500.00	\$3,500.00	
46	Water Service (1 Inch)					
	237110	EA	122	\$2,400.00	\$292,800.00	
47	Water Service (2 Inch)					
	237110	EA	6	\$3,500.00	\$21,000.00	
48	Water Service Transfer (1 Inch)					
	237110	EA	1	\$1,700.00	\$1,700.00	
49	Blow-Off Valve Assembly (2 Inch)					
	237110	EA	1	\$8,000.00	\$8,000.00	
50	Air and Vacuum (Air Release) Valve Assembly					
	237110	EA	1	\$8,000.00	\$8,000.00	
51	Temporary Resurfacing					
	237310	TON	500	\$110.00	\$55,000.00	
52	Imported Backfill For Trench					
	237110	TON	400	\$30.00	\$12,000.00	

Bid Results

Type	Item Code	UOM	Qty	Unit Price	Line Total	Comment
53	Manholes (4 ft x 3 ft)					
	237110	EA	26	\$4,700.00	\$122,200.00	
54	Connection to Existing Manhole and Rechanneling					
	237110	EA	1	\$2,900.00	\$2,900.00	
55	Sewer Lateral and Cleanout (4 Inch, Street)					
	237110	EA	68	\$2,650.00	\$180,200.00	
56	6 Inch Sewer Main Cleanout					
	237110	EA	1	\$520.00	\$520.00	
57	Sewer Lateral with Private Replumbing (4 Inch) for 3566 Emerson Street					
	237110	EA	1	\$28,000.00	\$28,000.00	
58	Sewer Lateral with Private Replumbing (4 Inch) for 3576 Emerson Street					
	237110	EA	1	\$23,000.00	\$23,000.00	
59	Sewer Lateral with Private Replumbing (4 Inch) including Backwater Device Assembly (4 Inch) for 3623 Fenelon Street					
	237110	EA	1	\$29,000.00	\$29,000.00	
60	Sewer Lateral with Private Replumbing (4 Inch) including Backwater Device Assembly (4 Inch) for 3617 Fenelon Street					
	237110	EA	1	\$29,000.00	\$29,000.00	
61	Sewer Lateral with Private Replumbing (4 Inch) including Backwater Device Assembly (4 Inch) for 3648 Cedarbrae Ln					
	237110	EA	1	\$26,000.00	\$26,000.00	
62	Sewer Lateral with Private Replumbing (4 Inch) including Backwater Device Assembly (4 Inch) for 3632 Cedarbrae Ln					
	237110	EA	1	\$26,000.00	\$26,000.00	
63	Sewer Lateral with Private Replumbing (4 Inch) including Backwater Device Assembly (4 Inch) for 3620 Cedarbrae Ln					
	237110	EA	1	\$26,000.00	\$26,000.00	
64	Sewer Lateral with Private Replumbing (4 Inch) including Backwater Device Assembly (4 Inch) for 3714 Cedarbrae Ln					
	237110	EA	1	\$27,000.00	\$27,000.00	
65	Cleaning and Video Inspection of Existing Pipelines and Culverts					
	237110	LF	7568	\$1.50	\$11,352.00	
66	Video Inspection of Pipelines and Culverts for Acceptance					
	237110	LF	7568	\$0.75	\$5,676.00	
67	Rehabilitate Sewer Main (6 Inch)					
	237110	LF	592	\$48.00	\$28,416.00	
68	Rehabilitate Sewer Main (8 Inch)					
	237110	LF	1469	\$40.00	\$58,760.00	

Bid Results

Type	Item Code	UOM	Qty	Unit Price	Line Total	Comment
69	Point Repair for Existing Sewer Main (8 inch)					
	237110	EA	3	\$7,500.00	\$22,500.00	
70	Additional Point Repair for Existing Sewer Main (8 inch)					
	237110	LF	6	\$980.00	\$5,880.00	
71	Service Lateral Rehabilitation with Manually Excavated Cleanout up to 7 ft in Depth					
	237110	EA	10	\$2,600.00	\$26,000.00	
72	Service Lateral Rehabilitation with Manually Excavated Cleanout greater than 7 ft in Depth					
	237110	EA	4	\$3,100.00	\$12,400.00	
73	Rehabilitate Existing Manhole with Cured-In-Place Manhole Liner					
	237110	VF	90	\$840.00	\$75,600.00	
74	Service Lateral Connection					
	237110	EA	16	\$1,400.00	\$22,400.00	
75	Traffic Control					
	237310	LS	1	\$75,000.00	\$75,000.00	
76	High-lining Removed by the Contractor					
	237110	LF	13500	\$1.00	\$13,500.00	
77	Pavement Restoration for Final Connection					
	237110	SF	1200	\$14.00	\$16,800.00	
78	Temporary Resurfacing					
	237110	TON	175	\$110.00	\$19,250.00	
				Subtotal	\$4,472,239.39	
	Main Bid GJ 821					
79	Bonds (Payment and Performance)					
	524126	LS	1	\$30,000.00	\$30,000.00	
80	Remote Control Camera Inspection (EOC Type II)					
	334290	AL	1	\$19,096.00	\$19,096.00	
81	Archaeological and Native American Monitoring Program					
	541690	LF	10120	\$4.00	\$40,480.00	
82	Paleontological Monitoring Program					
	541690	LF	7700	\$5.00	\$38,500.00	
83	Archaeological and Native American Mitigation and Curation (EOC Type I)					
	541690	AL	1	\$5,000.00	\$5,000.00	

Bid Results

Type	Item Code	UOM	Qty	Unit Price	Line Total	Comment
84	Paleontological Mitigation and Excavation					
	541690	CY	1800	\$1.00	\$1,800.00	
85	Suspension of Work - Resources					
	541690	DAYS	5	\$250.00	\$1,250.00	
86	Sewage Bypass and Pumping Plan (Diversion Plan)					
	237110	LS	1	\$3,000.00	\$3,000.00	
87	WPCP Development					
	541330	LS	1	\$4,500.00	\$4,500.00	
88	WPCP Implementation					
	237110	LS	1	\$59,000.00	\$59,000.00	
89	Video Recording of Existing Conditions					
	238990	LS	1	\$5,000.00	\$5,000.00	
90	Mobilization					
	237110	LS	1	\$150,000.00	\$150,000.00	
91	Field Orders (EOC Type II)					
		AL	1	\$250,000.00	\$250,000.00	
92	Additional Pavement Removal and Disposal					
	237310	CY	100	\$182.00	\$18,200.00	
93	Adjust Existing Manhole Frame and Cover to Grade					
	237310	EA	31	\$400.00	\$12,400.00	
94	Adjust Existing Gate Valve Frame and Cover to Grade					
	237310	EA	55	\$250.00	\$13,750.00	
95	Adjust Survey Monument to Grade					
	237310	EA	1	\$2,000.00	\$2,000.00	
96	Cold Mill AC Pavement (>1-1/2 Inch - 3 Inch)					
	237310	SF	77500	\$0.40	\$31,000.00	
97	Rubber Polymer Modified Slurry (RPMS) Type I Over Type II and Striping					
	237310	SF	126913	\$0.41	\$52,034.33	
98	Pavement Restoration Adjacent to Trench					
	237310	SF	13000	\$4.00	\$52,000.00	
99	Asphalt Concrete Overlay and Striping					
	237310	TON	2500	\$117.00	\$292,500.00	

Bid Results

Type	Item Code	UOM	Qty	Unit Price	Line Total	Comment
100	Concrete Pavement (6 Inch Thick)					
	238910	CY	100	\$575.00	\$57,500.00	
101	Cross Gutter					
	238910	SF	500	\$19.00	\$9,500.00	
102	Pavement Fabric					
	237310	SF	130000	\$0.32	\$41,600.00	
103	Crack Seal					
	237310	LB	125	\$20.00	\$2,500.00	
104	Additional Curb & Gutter Removal and Replacement					
	237310	LF	100	\$65.00	\$6,500.00	
105	Alley Apron					
	237310	SF	1200	\$19.00	\$22,800.00	
106	Curb Ramp (Type D) with Detectable Warning Tiles					
	237310	EA	3	\$2,900.00	\$8,700.00	
107	Additional Sidewalk					
	237310	SF	100	\$13.00	\$1,300.00	
108	Abandon Existing Manhole Outside of Trench Limit					
	237110	EA	15	\$500.00	\$7,500.00	
109	Removal or Abandonment of Existing Water Facilities					
	237110	LF	2600	\$2.00	\$5,200.00	
110	Abandon and Fill Existing Sewer Main (8 Inch) Outside of the Trench Limit					
	237110	LF	5163	\$3.00	\$15,489.00	
111	Handling and Disposal of Non-friable Asbestos Material					
	237110	LF	3759	\$11.00	\$41,349.00	
112	Additional Bedding					
	237110	CY	300	\$70.00	\$21,000.00	
113	Water Main (8 Inch)					
	237110	LF	6264	\$82.00	\$513,648.00	
114	Sewer Main (8 Inch)					
	237110	LF	5896	\$128.00	\$754,688.00	
115	Sewer Main (8 Inch, SDR-26)					
	237110	LF	1536	\$233.00	\$357,888.00	

Bid Results

Type	Item Code	UOM	Qty	Unit Price	Line Total	Comment
116	Trench Shoring					
	237110	LS	1	\$33,000.00	\$33,000.00	
117	Gate Valve (8 Inch)					
	237110	EA	11	\$1,600.00	\$17,600.00	
118	Fire Hydrant Assembly and Marker (6 Inch) 2 Ports					
	237110	EA	11	\$7,100.00	\$78,100.00	
119	Water Service (1 Inch)					
	237110	EA	108	\$2,400.00	\$259,200.00	
120	Water Service (2 Inch)					
	237110	EA	5	\$3,300.00	\$16,500.00	
121	Blow-Off Valve Assembly (2 Inch)					
	237110	EA	1	\$6,500.00	\$6,500.00	
122	Air and Vacuum (Air Release) Valve Assembly					
	237110	EA	2	\$5,200.00	\$10,400.00	
123	Temporary Resurfacing					
	237310	TON	250	\$110.00	\$27,500.00	
124	Imported Backfill For Trench					
	237110	TON	400	\$35.00	\$14,000.00	
125	Manholes (4 ft x 3 ft)					
	237110	EA	34	\$4,400.00	\$149,600.00	
126	Connection to Existing Manhole and Rechanneling					
	237110	EA	1	\$4,200.00	\$4,200.00	
127	Sewer Lateral and Cleanout (4 Inch, Street)					
	237110	EA	110	\$2,700.00	\$297,000.00	
128	Sewer Lateral and Cleanout (4 Inch, Alley)					
	237110	EA	25	\$1,500.00	\$37,500.00	
129	4 Inch Sewer Main Cleanout					
	237110	EA	2	\$480.00	\$960.00	
130	Sewer Lateral with Private Replumbing (4 Inch) for 955 Albion St.					
	237110	EA	1	\$26,000.00	\$26,000.00	
131	Sewer Lateral with Private Replumbing (4 Inch) for 959 Albion St.					
	237110	EA	1	\$26,000.00	\$26,000.00	

Sewer & AC Water GJ 764 & 821 (K-17-1544-DBB-3), bidding on May 5, 2017 2:00 PM (Pacific)

Printed 05/05/2017

Bid Results

Type	Item Code	UOM	Qty	Unit Price	Line Total	Comment
132	Sewer Lateral with Private Replumbing (4 Inch) including Backwater Device Assembly (4 Inch) for 570 Gage Dr.					
	237110	EA	1	\$32,000.00	\$32,000.00	
133	Sewer Lateral with Private Replumbing (4 Inch) including Backwater Device Assembly (4 Inch) for 578 Gage Dr.					
	237110	EA	1	\$32,000.00	\$32,000.00	
134	Sewer Lateral with Private Replumbing (4 Inch) including Backwater Device Assembly (4 Inch) for 549 Albion Street					
	237110	EA	1	\$33,000.00	\$33,000.00	
135	Cleaning and Video Inspection of Existing Pipelines and Culverts					
	237110	LF	8242	\$1.50	\$12,363.00	
136	Video Inspection of Pipelines and Culverts for Acceptance					
	237110	LF	8242	\$0.75	\$6,181.50	
137	Rehabilitate Sewer Main (8 Inch)					
	237110	LF	650	\$42.00	\$27,300.00	
138	Point Repair for Existing Sewer Main (8 inch)					
	237110	EA	2	\$7,500.00	\$15,000.00	
139	Additional Point Repair for Existing Sewer Main (8 inch)					
	237110	LF	6	\$990.00	\$5,940.00	
140	Service Lateral Rehabilitation with Manually Excavated Cleanout up to 7 ft in Depth					
	237110	EA	5	\$2,600.00	\$13,000.00	
141	Service Lateral Rehabilitation with Manually Excavated Cleanout greater than 7 ft in Depth					
	237110	EA	2	\$3,100.00	\$6,200.00	
142	Rehabilitate Existing Manhole with Cured-In-Place Manhole Liner					
	237110	VF	35	\$840.00	\$29,400.00	
143	Service Lateral Connection					
	237110	EA	7	\$1,400.00	\$9,800.00	
144	Traffic Control					
	237310	LS	1	\$80,000.00	\$80,000.00	
145	High-lining Removed by the Contractor					
	237110	LF	13000	\$1.00	\$13,000.00	
146	Pavement Restoration for Final Connection					
	237110	SF	650	\$14.00	\$9,100.00	
147	Temporary Resurfacing					
	237110	TON	332	\$110.00	\$36,520.00	
				Subtotal	\$4,313,536.83	

Bid Results

Type	Item Code	UOM	Qty	Unit Price	Line Total	Comment
Alternative A Bid GJ 764						
148	High-lining Installation by the Contractor					
	237110	LF	13500	\$9.00	\$121,500.00	
149	Furnished Materials for Contractor High-line Work					
	237110	LF	13500	\$1.50	\$20,250.00	
				Subtotal	\$141,750.00	
Alternative B Bid GJ 764						
150	Connections to The Existing System by Contractor (8 Inch through 12 Inch)					
	237110	EA	29	\$7,500.00	\$217,500.00	
151	Cut-in Tee by Contractor (8 Inch through 12 Inch)					
	237110	EA	6	\$14,000.00	\$84,000.00	
152	Cut and Plug by Contractor					
	237110	EA	21	\$2,700.00	\$56,700.00	
				Subtotal	\$358,200.00	
Alternative C Bid GJ 821						
153	High-lining Installation by the Contractor					
	237110	LF	13000	\$9.00	\$117,000.00	
154	Furnished Materials for Contractor High-line Work					
	237110	LF	13000	\$1.50	\$19,500.00	
				Subtotal	\$136,500.00	
Alternative D Bid GJ 821						
155	Connections to The Existing System by Contractor (8 Inch through 12 Inch)					
	237110	EA	17	\$7,500.00	\$127,500.00	
156	Cut-in Tee by Contractor (8 Inch through 12 Inch)					
	237110	EA	1	\$13,000.00	\$13,000.00	
157	Cut and Plug by Contractor					
	237110	EA	15	\$2,600.00	\$39,000.00	
				Subtotal	\$179,500.00	
				Total	\$9,601,726.22	

Subcontractors

Name & Address	Description	License Num	CADIR	Amount	Type
RAP Engineering, Inc. 503 E. Mission Road San Marcos, CA 92069 United States	Constructor AC Paving SLBE	880956	1000002968	\$1,625,200.00	CADIR,DBE,LAT,MA LE,MBE,SDB,SLBE
YBS CONCRETE INC. PO BOX 1197 CHULA VISTA, CA 91911 United States	Constructor Concrete Flatwork SLBE	885270	1000005185	\$151,150.00	LAT,MALE,SLBE,CA DIR
Southwest Pipeline and Trenchless Corp. 22118 S. Vermont Avenue Torrance, CA 90502 United States	Constructor Sewer Rehab	773862	1000002176	\$124,551.00	CADIR,PQUAL
		PlanetBids, Inc.			

Sewer & AC Water GJ 764 & 821 (K-17-1544-DBB-3), bidding on May 5, 2017 2:00 PM (Pacific)

Printed 05/05/2017

Bid Results

Name & Address	Description	License Num	CADIR	Amount	Type
Affordable Drain Service, Inc. 8340 Juniper Creek Lane San Diego, CA 92126 United States	Constructor CCTV SLBE	790919	1000010965	\$30,039.00	CAU,MALE,SLBE
American Asphalt South, Inc. PO Box 310036 14436 Santa Ana Ave Fontana, CA 92331 United States	Constructor Crack Seal	784969	1000000645	\$86,289.16	CAU,MALE,PQUAL, CADIR
Loveless & Linton Consulting- Archaeological 1421 W. Lewis St San Diego, CA 92103 United States	Consultant Archeo. Native American Monitoring SLBE	NA	10000011264	\$131,450.00	NAT,MALE,SLBE,DB E,CADIR,SDB
Ayala Engineering 8482 Meadowridge St Anaheim, CA 92808 United States	Constructor Manhole Rehab	959385	1000005012	\$102,500.00	
Statewide Stripes Inc. PO Box 600710 San Diego, CA 92160 United States	Constructor Striping	788286	1000001334	\$9,945.00	DBE
R & C Structures 1615 La Mirada Dr San Diego, CA 92078 United States	Constructors Sewer Manholes	425215	1000425215	\$179,738.00	
Maxim Construction Co., Inc. 8005 Royal Gardens Place El Cajon, CA 92021 United States	Constructor Portions of Sewer ELBE	1000689	10000000000	\$229,450.00	Asian,ELBE,FEM,W OSB

City of San Diego

CITY CONTACT: Rosa Riego, Contract Specialist, Email: RRiego@sandiego.gov
Phone No. (619) 533-3426, Fax No. (619) 533-3633

ADDENDUM B



FOR

SEWER & AC WATER GJ 764 & 821

BID NO.: K-17-1544-DBB-3
SAP NO. (WBS/IO/CC).: B-15106, B-00368, B-15107, B-00413
CLIENT DEPARTMENT: 2000
COUNCIL DISTRICT: 2
PROJECT TYPE: KB, JA

BID DUE DATE:

2:00 PM

MAY 5, 2017

CITY OF SAN DIEGO

PUBLIC WORKS CONTRACTS

1010 SECOND AVENUE, 14th FLOOR, MS 614C

SAN DIEGO, CA 92101

A. CLARIFICATION

1. The PlanetBids line items in the Unit Price column have been updated.

James Nagelvoort, Director
Public Works Department

Dated: *May 3, 2017*
San Diego, California

JN/RWB/mlw

City of San Diego

CITY CONTACT: Rosa Riego, Contract Specialist, Email: RRiego@sandiego.gov
Phone No. (619) 533-3426, Fax No. (619) 533-3633

ADDENDUM "A"



FOR

SEWER & AC WATER GJ 764 & 821

BID NO.:	<u>K-17-1544-DBB-3</u>
SAP NO. (WBS/IO/CC).:	<u>B-15106, B-00368, B-15107, B-00413</u>
CLIENT DEPARTMENT:	<u>2000</u>
COUNCIL DISTRICT:	<u>2</u>
PROJECT TYPE:	<u>KB, JA</u>

BID DUE DATE:

2:00 PM

MAY 5, 2017

CITY OF SAN DIEGO

PUBLIC WORKS CONTRACTS

1010 SECOND AVENUE, 14th FLOOR, MS 614C

SAN DIEGO, CA 92101

ENGINEER OF WORK

The engineering Specifications and Special Provisions contained herein have been prepared by or under the direction of the following Registered Engineer:

Nabil Samih Batta
For City Engineer

4/24/2017
Date

Seal:

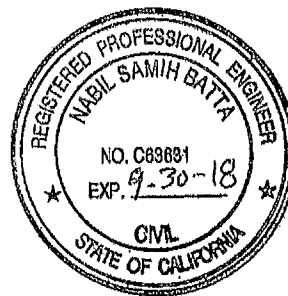

A. CHANGES TO CONTRACT DOCUMENTS

The following changes to the Contract Documents are hereby made effective as though originally issued with the bid package. Bidders are reminded that all previous requirements to this solicitation remain in full force and effect.

THE SUBMITTAL DATE FOR THIS PROJECT HAS BEEN **EXTENDED AS STATED ON THE COVER PAGE.**

B. NOTICE INVITING BIDS

1. To Item 3, Estimated Construction Cost, page 4, **DELETE** in its entirety and **SUBSTITUTE** with the following:

3. **ESTIMATED CONSTRUCTION COST:** The City's estimated construction cost for this project is **\$8,920,000.**

C. ATTACHMENTS

1. To Attachment A, Scope of Work, item 2, Estimated Construction Cost, page 21, **DELETE** in its entirety and **SUBSTITUTE** with the following:

2. **ESTIMATED CONSTRUCTION COST:** The City's estimated construction cost for this project is **\$8,920,000.**

2. To Attachment B, Phased Funding Provisions, pages 23 and 24, **DELETE** in its entirety and **SUBSTITUTE** with the following pages 4 through 5 of this addendum:

PHASED FUNDING PROVISIONS

1. PRE-AWARD

1.1. Within 10 Working Days after the Bid Opening date, the Apparent Low Bidder must contact the Project Manager to discuss fund availability for each phase and shall also submit the following:

1.1.1. Construction Cost Loaded Schedule in accordance with 6-1, "CONSTRUCTION SCHEDULE AND COMMENCEMENT OF THE WORK" and 9-3, "PAYMENT.

1.2. Your failure to perform any of the following may result cancelling your award of the Contract:

1.2.1. Meeting with the City's Project Manager to discuss the Phased Funding Schedule.

1.2.2. Agreeing to a Phased Funding Schedule within 22 Working Days after meeting with the City's Project Manager.

2. POST-AWARD

2.1. Do not start any construction activities for the next phase until the NTP has been issued by the Engineer. The City will issue separate Notice to Proceed (NTP) documents for each phase.

2.2. If requested, the Engineer may issue the NTP for the next phase before the end of the current approved phase.

PHASED FUNDING SCHEDULE AGREEMENT

NOTE: THIS IS A SAMPLE PHASED FUNDING SCHEDULE AGREEMENT FORM.

The particulars left blank in this sample, such as the total number of phases and the amounts assigned to each phase, will be completed with funding specific information from the Pre-Award Schedule and Construction Cost Loaded Schedule submitted to and approved by the City.

BID NUMBER: _____

CONTRACT OR TASK TITLE: _____

CONTRACTOR: _____

Funding Phase	Phase Description	Phase Start	Phase Finish	Not-to-Exceed Amount
1				\$
2	<u>All Additional phases to be added</u>			
	<u>to this form as necessary.</u>			
Contract Total				\$

Notes:

- 1) WHITEBOOK section 9-3.6, "Phased Funding Compensation" applies.
- 2) The total of all funding phases shall be equal to the TOTAL BID PRICE as shown on BID SCHEDULE 1 - PRICES.
- 3) This PHASED FUNDING SCHEDULE AGREEMENT will be incorporated into the CONTRACT and shall only be revised by written modifications to the CONTRACT.

CITY OF SAN DIEGO

CONTRACTOR

PRINT NAME: _____

PRINT NAME: _____

Construction Manager

Signature: _____

Title: _____

Date: _____

Signature: _____

PRINT NAME: _____

Date: _____

Project Manager

Signature: _____

Date: _____

D. ADDITIONAL CHANGES

The following are changes in the **Line Items Tab** in **PlanetBids**.

For clarity where applicable, ADDITIONS, if any, have been **Underlined** and **DELETIONS**, if any, have been ~~Stricken out~~.

Section	Item Code	Item Desc	UnitOf Measure	Quantity	Reference
Main Bid GJ 764	237110	Water Main (8 Inch)	LF	<u>5104</u> 5704	306-15.1
Main Bid GJ 764	237710	Water Main (8 Inch, DR-14)	LF	<u>975</u> 269	306-15.1
<u>Main Bid GJ 764</u>	<u>237110</u>	<u>Sewer Lateral with Private Replumbing (4 Inch) for 3576 Emerson Street</u>	<u>EA</u>	<u>1</u>	<u>306-17.2</u>
Main Bid GJ 764	237110	Rehabilitate Existing Manhole with Cured-In-Place Manhole Liner	VF	<u>90</u>	500-2.11.6
<u>Main Bid GJ 821</u>	<u>237110</u>	<u>Sewer Lateral with Private Replumbing (4 Inch) for 955 Albion St.</u>	<u>EA</u>	<u>1</u>	<u>306-17.2</u>

James Nagelvoort, Director
Public Works Department

Dated: *April 24, 2017*
San Diego, California

JN/RWB/mlw