

City of San Diego

CONTRACTOR'S NAME: Tri-Group Construction & Development, Inc.
ADDRESS: 9580 Black Mountain Rd, Ste L, San Diego, CA 92126
TELEPHONE NO.: (858) 689-0058 **FAX NO.:** _____
CITY CONTACT: Juan E. Espindola Senior Contract Specialist, Email: JEEspindola@sandiego.gov
Phone No. (619) 533-4491
Y. Lewis / R.W. Bustamante / I. Garcia

BIDDING DOCUMENTS



FOR

WANGENHEIM NEIGHBORHOOD PARK JOINT USE FACILITY

BID NO.: K-21-1986-DBB-3
SAP NO. (WBS/IO/CC): S-15007
CLIENT DEPARTMENT: 1714
COUNCIL DISTRICT: 6
PROJECT TYPE: GB, GF, BS

THIS CONTRACT WILL BE SUBJECT TO THE FOLLOWING:

- THE CITY'S SUBCONTRACTING PARTICIPATION REQUIREMENTS FOR SLBE PROGRAM
- PREVAILING WAGE RATES: STATE FEDERAL
- APPRENTICESHIP

BID DUE DATE:

2:00 PM

DECEMBER 9, 2020

CITY OF SAN DIEGO'S ELECTRONIC BIDDING SITE, PLANETBIDS

<http://www.sandiego.gov/cip/bidopps/index.shtml>

ENGINEER OF WORK

The engineering Specifications and Special Provisions contained herein have been prepared by or under the direction of the following Registered Engineers:

1) For Registered Engineer

10-28-20
Date

Seal:



2) For City Engineer

11/02/20
Date

Seal:

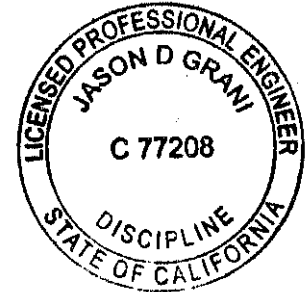

TABLE OF CONTENTS

SECTION	PAGE
1. REQUIRED DOCUMENTS SCHEDULE.....	4
2. NOTICE INVITING BIDS.....	6
3. INSTRUCTIONS TO BIDDERS	9
4. PERFORMANCE AND PAYMENT BONDS	20
5. ATTACHMENTS:	
A. SCOPE OF WORK.....	23
B. RESERVED.....	25
C. RESERVED.....	26
D. PREVAILING WAGE.....	27
E. SUPPLEMENTARY SPECIAL PROVISIONS.....	32
TECHNICALS	61
1. Appendix A - Notice of Exemption	561
2. Appendix B - Fire Hydrant Meter Program	564
3. Appendix C - Materials Typically Accepted by Certificate of Compliance	578
4. Appendix D - Sample City Invoice with Cash Flow Forecast.....	580
5. Appendix E - Location Map	583
6. Appendix F - Adjacent Project Map.....	585
7. Appendix G - Sample of Public Notice	587
8. Appendix H - Advanced Metering Infrastructure (AMI) Device Protection	589
9. Appendix I - Munition of Explosive Concern Specifications	596
10. Appendix J - SWPPP Construction BMP Maintenance Log.....	602
F. RESERVED.....	605
G. CONTRACT AGREEMENT	606
6. CERTIFICATIONS AND FORMS.....	609

REQUIRED DOCUMENTS SCHEDULE DURING BIDDING AND AWARDING

The Bidder's attention is directed to the City's Municipal Code §22.0807(e), (3)-(5) for important information regarding grounds for debarment for failure to submit required documentation.

The specified Equal Opportunity Contracting Program (EOCP) forms are available for download from the City's web site at:

<http://www.sandiego.gov/eoc/forms/index.shtml>

ITEM	DOCUMENT TO BE SUBMITTED	WHEN DUE	FROM
1.	Bid Bond (PDF via PlanetBids)	At Time of Bid	ALL BIDDERS
2.	Contractors Certification of Pending Actions	At Time of Bid	ALL BIDDERS
3.	Mandatory Disclosure of Business Interests	At Time of Bid	ALL BIDDERS
4.	Debarment and Suspension Certification for Prime Contractors	At Time of Bid	ALL BIDDERS
5.	Debarment and Suspension Certification for Subcontractors, Suppliers & Mfgrs	At Time of Bid	ALL BIDDERS
6.	Bid Bond (Original)	By 5PM 3 working days after bid opening	ALL BIDDERS
7.	SLBE Good Faith Effort Documentation	By 5 PM 3 working days after bid opening	ALL BIDDERS
8.	Form AA60 – List of Work Made Available	By 5 PM 3 working days after bid opening with Good Faith Effort (GFE) documentation	ALL BIDDERS
9.	If the Contractor is a Joint Venture: <ul style="list-style-type: none"> • Joint Venture Agreement • Joint Venture License 	Within 10 working days of receipt by bidder of contract forms	APPARENT LOW BIDDER
10.	Payment & Performance Bond; Certificates of Insurance & Endorsements; and Signed Contract Agreement Page	Within 10 working days of receipt by bidder of contract forms and NOI	APPARENT LOW BIDDER

ITEM	DOCUMENT TO BE SUBMITTED	WHEN DUE	FROM
11.	Listing of "Other Than First Tier" Subcontractors	Within 10 working days of receipt by bidder of contract forms	APPARENT LOW BIDDER

NOTICE INVITING BIDS

1. **SUMMARY OF WORK:** This is the City of San Diego's (City) solicitation process to acquire Construction services for **Wangenheim Neighborhood Park Joint Use Facility**. For additional information refer to Attachment A.
2. **FULL AND OPEN COMPETITION:** This solicitation is subject to full and open competition and may be bid by Contractors on the City's approved Prequalified Contractors List. For information regarding the Contractors Prequalified list visit the City's web site: <http://www.sandiego.gov>.
3. **ESTIMATED CONSTRUCTION COST:** The City's estimated construction cost for this project is **\$6,750,000**.
4. **BID DUE DATE AND TIME ARE:** **December 9, 2020 at 2:00 p.m.**
5. **PREVAILING WAGE RATES APPLY TO THIS CONTRACT:** Refer to Attachment D.
6. **LICENSE REQUIREMENT:** To be eligible for award of this contract, Prime contractor must possess the following licensing classification: **A**
 - 6.1. **ADDITIONAL CERTIFICATION REQUIREMENTS:** Certification for a UXO Technician Level III shall be required in accordance with **Appendix I - Munition of Explosive Concern Specifications**.
7. **SUBCONTRACTING PARTICIPATION PERCENTAGES:** Subcontracting participation percentages apply to this contract.
 - 7.1. The City has incorporated **mandatory** SLBE-ELBE subcontractor participation percentages to enhance competition and maximize subcontracting opportunities. For the purpose of achieving the mandatory subcontractor participation percentages, a recommended breakdown of the SLBE and ELBE subcontractor participation percentages based upon certified SLBE and ELBE firms has also been provided to achieve the mandatory subcontractor participation percentages:

1. SLBE participation	7.9%
2. ELBE participation	9.3%
3. Total mandatory participation	17.2%
 - 7.2. The Bid may be declared non-responsive if the Bidder fails to meet the following requirements:
 - 7.2.1. Include SLBE-ELBE certified subcontractors at the overall mandatory participation percentage identified in this document; OR
 - 7.2.2. Submit Good Faith Effort (GFE) documentation, saved in searchable Portable Document Format (PDF) and stored on a Universal Serial Bus (USB) Type-A, Compact Disc (CD) or Digital Video Disc (DVD), demonstrating the Bidder made

a good faith effort to outreach to and include SLBE-ELBE Subcontractors required in this document by 5 PM 3 Working Days after the Bid opening if the overall mandatory participation percentage is not met.

Due to circumstances related to Covid-19, until further notice, all submittals in searchable PDF shall be submitted electronically within the prescribed time identified in the contract documents via a File Cloud link provided by the Contract Specialist to all bidders.

Upon circumstances returning to normal business as usual, the GFE shall once again be submitted to:

Engineering & Capital Projects Department, Contracts Division
525 B Street, Suite 750 (7th Floor)
San Diego, California, 92101
Attention: Juan E. Espindola

8. AWARD PROCESS:

- 8.1.** The Award of this contract is contingent upon the Contractor's compliance with all conditions of Award as stated within these documents and within the Notice of Intent to Award.
- 8.2.** Upon acceptance of bids and determination of the apparent low bidder, the City will prepare the contract documents for execution within approximately 21 days of the date of the bid opening. The City will then award the contract upon receipt of properly signed Contract, bonds, and insurance documents.
- 8.3.** This contract will be deemed executed and effective only upon the signing of the Contract by the Mayor or his designee and approval as to form by the City Attorney's Office.
- 8.4.** The low Bid will be determined by the Base Bid.
- 8.5.** Once the low bid has been determined, the City may, at its sole discretion, award the contract for the Base bid alone.

9. SUBMISSION OF QUESTIONS:

- 9.1.** The Director (or Designee) of the Engineering & Capital Projects Department is the officer responsible for opening, examining, and evaluating the competitive Bids submitted to the City for the acquisition, construction and completion of any public improvement except when otherwise set forth in these documents. Any questions related to this solicitation shall be submitted to:

Engineering & Capital Projects Department, Contracts Division
525 B Street, Suite 750 (7th Floor)
San Diego, California, 92101
Attention: Juan E. Espindola

OR:

JEEspindola@sandiego.gov

- 9.2.** Questions received less than 14 days prior to the date for opening of Bids may not be considered.
- 9.3.** Questions or clarifications deemed by the City to be material shall be answered via issuance of an addendum and posted to the City's online bidding service.
- 9.4.** Only questions answered by formal written addenda shall be binding. Oral and other interpretations or clarifications shall be without legal effect. It is the Bidder's responsibility to be informed of any addenda that have been issued and to include all such information in its Bid.

INSTRUCTIONS TO BIDDERS

1. PREQUALIFICATION OF CONTRACTORS:

- 1.1. Contractors submitting a Bid must be pre-qualified for the total amount proposed, including all alternate items, prior to the date of submittal. Bids from contractors who have not been pre-qualified as applicable and Bids that exceed the maximum dollar amount at which contractors are pre-qualified may be deemed **non-responsive** and ineligible for award.
- 1.2. The completed application must be submitted online no later than 2 weeks prior to the bid opening.
- 1.3. **Joint Venture Bidders Cumulative Maximum Bidding Capacity:** For projects with an engineer's estimate of \$30,000,000 or greater, Joint Ventures submitting bids may be deemed responsive and eligible for award if the cumulative maximum bidding capacity of the individual Joint Venture entities is equal to or greater than the total amount proposed.
 - 1.3.1. Each of the entities of the Joint Venture must have been previously prequalified at a minimum of \$15,000,000.
 - 1.3.2. Bids submitted with a total amount proposed of less than \$30,000,000 are not eligible for Cumulative Maximum Bidding Capacity prequalification. To be eligible for award in this scenario, the Joint Venture itself or at least one of the Joint Venture entities must have been prequalified for the total amount proposed.
 - 1.3.3. Bids submitted by Joint Ventures with a total amount proposed of \$30,000,000 or greater on a project with an engineer's estimate of less than \$30,000,000 are not eligible for Cumulative Maximum Bidding Capacity prequalification.
 - 1.3.4. The Joint Venture designated as the Apparent Low Bidder shall provide evidence of its corporate existence and furnish good and approved bonds in the name of the Joint Venture within 14 Calendar Days of receipt by the Bidder of a form of contract for execution.
- 1.4. Complete information and links to the on-line prequalification application are available at:

<http://www.sandiego.gov/cip/bidopps/prequalification>
- 1.5. Due to the City's responsibility to protect the confidentiality of the contractors' information, City staff will not be able to provide information regarding contractors' prequalification status over the telephone. Contractors may access real-time information about their prequalification status via their vendor profile on [PlanetBids™](#).

2. **ELECTRONIC FORMAT RECEIPT AND OPENING OF BIDS:** Bids will be received in electronic format (eBids) EXCLUSIVELY at the City of San Diego's electronic bidding (eBidding) site, at: <http://www.sandiego.gov/cip/bidopps/index.shtml> and are due by the date, and time shown on the cover of this solicitation.
- 2.1. **BIDDERS MUST BE PRE-REGISTERED** with the City's bidding system and possess a system-assigned Digital ID in order to submit an electronic bid.
- 2.2. The City's bidding system will automatically track information submitted to the site including IP addresses, browsers being used and the URLs from which information was submitted. In addition, the City's bidding system will keep a history of every login instance including the time of login, and other information about the user's computer configuration such as the operating system, browser type, version, and more. Because of these security features, Contractors who disable their browsers' cookies will not be able to log in and use the City's bidding system.
- 2.3. The City's electronic bidding system is responsible for bid tabulations. Upon the bidder's or proposer's entry of their bid, the system will ensure that all required fields are entered. **The system will not accept a bid for which any required information is missing.** This includes all necessary pricing, subcontractor listing(s) and any other essential documentation and supporting materials and forms requested or contained in these solicitation documents.
- 2.4. **BIDS REMAIN SEALED UNTIL BID DEADLINE.** eBids are transmitted into the City's bidding system via hypertext transfer protocol secure (https) mechanism using SSL 128-256 bit security certificates issued from Verisign/Thawte which encrypts data being transferred from client to server. Bids submitted prior to the "Bid Due Date and Time" are not available for review by anyone other than the submitter who has until the "Bid Due Date and Time" to change, rescind or retrieve its proposal should it desire to do so.
- 2.5. **BIDS MUST BE SUBMITTED BY BID DUE DATE AND TIME.** Once the bid deadline is reached, no further submissions are accepted into the system. Once the Bid Due Date and Time has lapsed, bidders, proposers, the general public, and City staff are able to immediately see the results on line. City staff may then begin reviewing the submissions for responsiveness, EOCB compliance and other issues. The City may require any Bidder to furnish statement of experience, financial responsibility, technical ability, equipment, and references.
- 2.6. **RECAPITULATION OF THE WORK.** Bids shall not contain any recapitulation of the Work. Conditional Bids may be rejected as being non-responsive. Alternative proposals will not be considered unless called for.

2.7. BIDS MAY BE WITHDRAWN by the Bidder only up to the bid due date and time.

2.7.1. Important Note: Submission of the electronic bid into the system may not be instantaneous. Due to the speed and capabilities of the user's internet service provider (ISP), bandwidth, computer hardware and other variables, it may take time for the bidder's submission to upload and be received by the City's eBidding system. It is the bidder's sole responsibility to ensure their bids are received on time by the City's eBidding system. The City of San Diego is not responsible for bids that do not arrive by the required date and time.

2.8. ACCESSIBILITY AND AMERICANS WITH DISABILITIES ACT (ADA) COMPLIANCE: To request a copy of this solicitation in an alternative format, contact the Engineering & Capital Projects Department Contract Specialist listed on the cover of this solicitation at least five (5) working days prior to the Bid/Proposal due date to ensure availability.

3. ELECTRONIC BID SUBMISSIONS CARRY FULL FORCE AND EFFECT:

3.1. The bidder, by submitting its electronic bid, acknowledges that doing so carries the same force and full legal effect as a paper submission with a longhand (wet) signature.

3.2. By submitting an electronic bid, the bidder certifies that the bidder has thoroughly examined and understands the entire Contract Documents (which consist of the plans and specifications, drawings, forms, affidavits and the solicitation documents), and that by submitting the eBid as its bid proposal, the bidder acknowledges, agrees to and is bound by the entire Contract Documents, including any addenda issued thereto, and incorporated by reference in the Contract Documents.

3.3. The Bidder, by submitting its electronic bid, agrees to and certifies under penalty of perjury under the laws of the State of California, that the certification, forms and affidavits submitted as part of this bid are true and correct.

3.4. The Bidder agrees to the construction of the project as described in Attachment "A-Scope of Work" for the City of San Diego, in accordance with the requirements set forth herein for the electronically submitted prices. The Bidder guarantees the Contract Price for a period of 120 days from the date of Bid opening. The duration of the Contract Price guarantee shall be extended by the number of days required for the City to obtain all items necessary to fulfill all conditions precedent.

4. BIDS ARE PUBLIC RECORDS: Upon receipt by the City, Bids shall become public records subject to public disclosure. It is the responsibility of the respondent to clearly identify any confidential, proprietary, trade secret or otherwise legally privileged information contained within the Bid. General references to sections of the California Public Records Act (PRA) will not suffice. If the Contractor does not provide applicable case law that clearly establishes that the requested information is exempt from the disclosure requirements of the PRA, the City shall be free to release the information when required in accordance with the PRA, pursuant

to any other applicable law, or by order of any court or government agency, and the Contractor will hold the City harmless for release of this information.

5. CONTRACTOR REGISTRATION AND ELECTRONIC REPORTING SYSTEM:

5.1. Prior to the Award of the Contract or Task Order, you and your Subcontractors and Suppliers must register with the City's web-based vendor registration and bid management system. For additional information go to:

<http://www.sandiego.gov/purchasing/bids-contracts/vendorreg>

5.2. The City may not award the contract until registration of all subcontractors and suppliers is complete. In the event this requirement is not met within the time frame specified in the Notice of Intent to Award letter, the City reserves the right to rescind the Notice of Award / Intent to Award and to make the award to the next responsive and responsible bidder / proposer.

6. JOINT VENTURE CONTRACTORS: Provide a copy of the Joint Venture agreement and the Joint Venture license to the City within 14 Calendar Days after receiving the Contract forms.

7. INSURANCE REQUIREMENTS:

7.1. All certificates of insurance and endorsements required by the contract are to be provided upon issuance of the City's Notice of Intent to Award letter.

7.2. Refer to sections 5-4, "INSURANCE" of the Supplementary Special Provisions (SSP) for the insurance requirements which must be met.

8. REFERENCE STANDARDS: Except as otherwise noted or specified, the Work shall be completed in accordance with the following standards:

Title	Edition	Document Number
Standard Specifications for Public Works Construction ("The GREENBOOK") http://www.greenbookspecs.org/	2018	PWPI010119-01
City of San Diego Standard Specifications for Public Works Construction ("The WHITEBOOK")* https://www.sandiego.gov/ecp/edocref/greenbook	2018	PWPI010119-02
City of San Diego Standard Drawings* https://www.sandiego.gov/ecp/edocref/standarddraw	2018	PWPI010119-03
Citywide Computer Aided Design and Drafting (CADD) Standards https://www.sandiego.gov/ecp/edocref/drawings	2018	PWPI010119-04
California Department of Transportation (CALTRANS) Standard Specifications https://dot.ca.gov/programs/design/ccs-standard-plans-and-standard-specifications	2018	PWPI030119-05

Title	Edition	Document Number
CALTRANS Standard Plans https://dot.ca.gov/programs/design/ccs-standard-plans-and-standard-specifications	2018	PWPI030119-06
California Manual on Uniform Traffic Control Devices Revision 5 (CA MUTCD 2014 Rev 5) http://www.dot.ca.gov/programs/safety-programs/camutcd/camutcd-rev5	2014	PWPI042220-09
<p>NOTE: *Available online under Engineering Documents and References at: https://www.sandiego.gov/ecp/edocref/</p> <p>*Electronic updates to the Standard Drawings may also be found in the link above</p>		

9. **CITY'S RESPONSES AND ADDENDA:** The City, at its discretion, may respond to any or all questions submitted in writing via the City's eBidding web site in the **form of an addendum**. No other responses to questions, oral or written shall be of any force or effect with respect to this solicitation. The changes to the Contract Documents through addenda are made effective as though originally issued with the Bid. The Bidders shall acknowledge the receipt of Addenda at the time of bid submission.
10. **CITY'S RIGHTS RESERVED:** The City reserves the right to cancel the Notice Inviting Bids at any time, and further reserves the right to reject submitted Bids, without giving any reason for such action, at its sole discretion and without liability. Costs incurred by the Bidder(s) as a result of preparing Bids under the Notice Inviting Bids shall be the sole responsibility of each bidder. The Notice Inviting Bids creates or imposes no obligation upon the City to enter a contract.
11. **CONTRACT PRICING:** This solicitation is for a Lump Sum contract with Unit Price provisions as set forth herein. The Bidder agrees to perform construction services for the City of San Diego in accordance with these contract documents for the prices listed below. The Bidder further agrees to guarantee the Contract Price for a period of 120 days from the date of Bid opening. The duration of the Contract Price guarantee may be extended, by mutual consent of the parties, by the number of days required for the City to obtain all items necessary to fulfill all contractual conditions.
12. **SUBCONTRACTOR INFORMATION:**
- 12.1. **LISTING OF SUBCONTRACTORS.** In accordance with the requirements provided in the "Subletting and Subcontracting Fair Practices Act" of the California Public Contract Code, the Bidder shall provide the **NAME** and **ADDRESS** of each Subcontractor who will perform work, labor, render services or who specially fabricates and installs a portion [type] of the work or improvement, in an amount in excess of 0.5% of the Contractor's total Bid. The Bidder shall also state within the description, whether the subcontractor is a **CONSTRUCTOR, CONSULTANT** or **SUPPLIER**. The Bidder shall state the **DIR REGISTRATION NUMBER** for all subcontractors and shall further state within the description, the **PORZION** of the work which will be performed by each

subcontractor under this Contract. The Contractor shall list only one Subcontractor for each portion of the Work. The **DOLLAR VALUE** of the total Bid to be performed shall be stated for all subcontractors listed. Failure to comply with this requirement may result in the Bid being rejected as **non-responsive** and ineligible for award. The Bidder's attention is directed to the Special Provisions – Section 3-2, “SELF-PERFORMANCE”, which stipulates the percent of the Work to be performed with the Bidders' own forces. The Bidder shall list all SLBE, ELBE, DBE, DVBE, MBE, WBE, OBE, SDB, WoSB, HUBZone, and SDVOSB Subcontractors for which Bidders are seeking recognition towards achieving any mandatory, voluntary (or both) subcontracting participation goals.

Additionally, pursuant to California Senate Bill 96 and in accordance with the requirements of Labor Code sections 1771.1 and 1725.5, by submitting a bid or proposal to the City, Contractor is certifying that he or she has verified that all subcontractors used on this public work project are registered with the California Department of Industrial Relations (DIR). **The Bidder shall provide the name, address, license number, DIR registration number of any Subcontractor – regardless of tier** - who will perform work, labor, render services or specially fabricate and install a portion [type] of the work or improvement pursuant to the contract.

12.2. LISTING OF SUPPLIERS. Any Bidder seeking the recognition of Suppliers of equipment, materials, or supplies obtained from third party Suppliers towards achieving any mandatory or voluntary (or both) subcontracting participation goals shall provide, at a minimum, the **NAME, LOCATION (CITY), DIR REGISTRATION NUMBER** and the **DOLLAR VALUE** of each supplier. The Bidder will be credited up to 60% of the amount to be paid to the Suppliers for materials and supplies unless vendor manufactures or substantially alters materials and supplies, in which case, 100% will be credited. The Bidder is to indicate within the description whether the listed firm is a supplier or manufacturer. If no indication is provided, the listed firm will be credited at 60% of the listed dollar value for purposes of calculating the Subcontractor Participation Percentage.

12.3. LISTING OF SUBCONTRACTORS OR SUPPLIERS FOR ALTERNATES. For subcontractors or suppliers to be used on additive or deductive alternate items, in addition to the above requirements, bidder shall further note “ALTERNATE” and alternate item number within the description.

13. SUBMITTAL OF “OR EQUAL” ITEMS: See Section 4-6, “Trade Names” in The WHITEBOOK and as amended in the SSP.

14. AWARD:

14.1. The Award of this contract is contingent upon the Contractor’s compliance with all conditions precedent to Award.

14.2. Upon acceptance of a Bid, the City will prepare contract documents for execution within approximately 21 days of the date of the Bid opening and award the Contract

approximately within 7 days of receipt of properly executed Contract, bonds, and insurance documents.

- 14.3.** This contract will be deemed executed and effective only upon the signing of the Contract by the Mayor or his designee and approval as to form the City Attorney's Office.
- 15. SUBCONTRACT LIMITATIONS:** The Bidder's attention is directed to Standard Specifications for Public Works Construction, Section 3-2, "SELF-PERFORMANCE" in The GREENBOOK and as amended in the SSP which requires the Contractor to self-perform not less than the specified amount. Failure to comply with this requirement shall render the bid **non-responsive** and ineligible for award.
- 16. AVAILABILITY OF PLANS AND SPECIFICATIONS:** Contract Documents may be obtained by visiting the City's website: <http://www.sandiego.gov/cip/>. Plans and Specifications for this contract are also available for review in the office of the City Clerk or Engineering & Capital Projects Department, Contracts Division.
- 17. ONLY ONE BID PER CONTRACTOR SHALL BE ACCEPTED:** No person, firm, or corporation shall be allowed to make, file, or be interested in more than one (1) Bid for the same work unless alternate Bids are called for. A person, firm or corporation who has submitted a sub-proposal to a Bidder, or who has quoted prices on materials to a Bidder, is not hereby disqualified from submitting a sub-proposal or quoting prices to other Bidders or from submitting a Bid in its own behalf. Any Bidder who submits more than one bid will result in the rejection of all bids submitted.
- 18. SAN DIEGO BUSINESS TAX CERTIFICATE:** The Contractor and Subcontractors, not already having a City of San Diego Business Tax Certificate for the work contemplated shall secure the appropriate certificate from the City Treasurer, Civic Center Plaza, First floor and submit to the Contract Specialist upon request or as specified in the Contract Documents. Tax Identification numbers for both the Bidder and the listed Subcontractors must be submitted on the City provided forms within these documents.
- 19. BIDDER'S GUARANTEE OF GOOD FAITH (BID SECURITY) FOR DESIGN-BID-BUILD CONTRACTS:**

 - 19.1.** For bids \$250,000 and above, bidders shall submit Bid Security at bid time. Bid Security shall be in one of the following forms: a cashier's check, or a properly certified check upon some responsible bank; or an approved corporate surety bond payable to the City of San Diego for an amount of not less than 10% of the total bid amount.
 - 19.2.** This check or bond, and the monies represented thereby, will be held by the City as a guarantee that the Bidder, if awarded the contract, will in good faith enter into the contract and furnish the required final performance and payment bonds.
 - 19.3.** The Bidder agrees that in the event of the Bidder's failure to execute this contract and provide the required final bonds, the money represented by the cashier's or certified check will remain the property of the City; and the Surety agrees that it will pay to the

City the damages, not exceeding the sum of 10% of the amount of the Bid, that the City may suffer as a result of such failure.

- 19.4.** At the time of bid submission, bidders must upload and submit an electronic PDF copy of the aforementioned bid security. Whether in the form of a cashier's check, a properly certified check or an approved corporate surety bond payable to the City of San Diego, the bid security must be uploaded to the City's eBidding system. By 5PM, 3 working days after the bid opening date, all bidders must provide the City with the original bid security.
- 19.5.** Failure to submit the electronic version of the bid security at the time of bid submission AND failure to provide the original by 5PM, 3 working days after the bid opening date shall cause the bid to be rejected and deemed **non-responsive**.

Due to circumstances related to Covid-19, until further notice, all original bid bond submittals must be received by 5 PM, 3 working days after bid opening.

Upon circumstances returning to normal business as usual, the original bid bond shall once again be due by 5 PM the day after bid opening.

Original Bid Bond shall be submitted to:
Engineering & Capital Projects Department, Contracts Division
525 B Street, Suite 750 (7th Floor)
San Diego, California, 92101
To the Attention of the Contract Specialist on the Front Page of this solicitation.

20. AWARD OF CONTRACT OR REJECTION OF BIDS:

- 20.1.** This contract may be awarded to the lowest responsible and reliable Bidder.
- 20.2.** Bidders shall complete ALL eBid forms as required by this solicitation. Incomplete eBids will not be accepted.
- 20.3.** The City reserves the right to reject any or all Bids, to waive any informality or technicality in Bids received, and to waive any requirements of these specifications as to bidding procedure.
- 20.4.** Bidders will not be released on account of their errors of judgment. Bidders may be released only upon receipt by the City within 3 Working Days of the bid opening, written notice from the Bidder which shows proof of honest, credible, clerical error of a material nature, free from fraud or fraudulent intent; and of evidence that reasonable care was observed in the preparation of the Bid.
- 20.5.** A bidder who is not selected for contract award may protest the award of a contract to another bidder by submitting a written protest in accordance with the San Diego Municipal Code.

- 20.6.** The City of San Diego will not discriminate in the award of contracts with regard to race, religion creed, color, national origin, ancestry, physical handicap, marital status, sex or age.
- 20.7.** Each Bid package properly signed as required by these specifications shall constitute a firm offer which may be accepted by the City within the time specified herein.
- 20.8.** The City reserves the right to evaluate all Bids and determine the lowest Bidder on the basis of the base bid and any proposed alternates or options as detailed herein.

21. BID RESULTS:

- 21.1.** The availability of the bids on the City's eBidding system shall constitute the public announcement of the apparent low bidder. In the event that the apparent low bidder is subsequently deemed non-responsive or non-responsible, a notation of such will be made on the eBidding system. The new ranking and apparent low bidder will be adjusted accordingly.
- 21.2.** To obtain the bid results, view the results on the City's web site, or request the results by U.S. mail and provide a self-addressed, stamped envelope. If requesting by mail, be sure to reference the bid name and number. The bid tabulations will be mailed to you upon their completion. The results will not be given over the telephone.

22. THE CONTRACT:

- 22.1.** The Bidder to whom award is made shall execute a written contract with the City of San Diego and furnish good and approved bonds and insurance certificates specified by the City within 14 days after receipt by Bidder of a form of contract for execution unless an extension of time is granted to the Bidder in writing.
- 22.2.** If the Bidder takes longer than 14 days to fulfill these requirements, then the additional time taken shall be added to the Bid guarantee. The Contract shall be made in the form adopted by the City, which includes the provision that no claim or suit whatsoever shall be made or brought by Contractor against any officer, agent, or employee of the City for or on account of anything done or omitted to be done in connection with this contract, nor shall any such officer, agent, or employee be liable hereunder.
- 22.3.** If the Bidder to whom the award is made fails to enter into the contract as herein provided, the award may be annulled and the Bidder's Guarantee of Good Faith will be subject to forfeiture. An award may be made to the next lowest responsible and reliable Bidder who shall fulfill every stipulation embraced herein as if it were the party to whom the first award was made.
- 22.4.** Pursuant to the San Diego City Charter section 94, the City may only award a public works contract to the lowest responsible and reliable Bidder. The City will require the

Apparent Low Bidder to (i) submit information to determine the Bidder's responsibility and reliability, (ii) execute the Contract in form provided by the City, and (iii) furnish good and approved bonds and insurance certificates specified by the City within 14 Days, unless otherwise approved by the City, in writing after the Bidder receives notification from the City, designating the Bidder as the Apparent Low Bidder and formally requesting the above mentioned items.

- 22.5.** The award of the Contract is contingent upon the satisfactory completion of the above-mentioned items and becomes effective upon the signing of the Contract by the Mayor or designee and approval as to form by the City Attorney's Office. If the Apparent Low Bidder does not execute the Contract or submit required documents and information, the City may award the Contract to the next lowest responsible and reliable Bidder who shall fulfill every condition precedent to award. A corporation designated as the Apparent Low Bidder shall furnish evidence of its corporate existence and evidence that the officer signing the Contract and bond for the corporation is duly authorized to do so.
- 23. EXAMINATION OF PLANS, SPECIFICATIONS, AND SITE OF WORK:** The Bidder shall examine carefully the Project Site, the Plans and Specifications, other materials as described in the Special Provisions, Section 3-9, "TECHNICAL STUDIES AND SUBSURFACE DATA", and the proposal forms (e.g., Bidding Documents). The submission of a Bid shall be conclusive evidence that the Bidder has investigated and is satisfied as to the conditions to be encountered, as to the character, quality, and scope of work, the quantities of materials to be furnished, and as to the requirements of the Bidding Documents Proposal, Plans, and Specifications.
- 24. CITY STANDARD PROVISIONS:** This contract is subject to the following standard provisions. See The WHITEBOOK for details.
- 24.1.** The City of San Diego Resolution No. R-277952 adopted on May 20, 1991 for a Drug-Free Workplace.
- 24.2.** The City of San Diego Resolution No. R-282153 adopted on June 14, 1993 related to the Americans with Disabilities Act.
- 24.3.** The City of San Diego Municipal Code §22.3004 for Contractor Standards.
- 24.4.** The City of San Diego's Labor Compliance Program and the State of California Labor Code §§1771.5(b) and 1776.
- 24.5.** Sections 1777.5, 1777.6, and 1777.7 of the State of California Labor Code concerning the employment of apprentices by contractors and subcontractors performing public works contracts.
- 24.6.** The City's Equal Benefits Ordinance (EBO), Chapter 2, Article 2, Division 43 of The San Diego Municipal Code (SDMC).

24.7. The City's Information Security Policy (ISP) as defined in the City's Administrative Regulation 90.63.

25. PRE-AWARD ACTIVITIES:

25.1. The contractor selected by the City to execute a contract for this Work shall submit the required documentation as specified in the herein and in the Notice of Award. Failure to provide the information as specified may result in the Bid being rejected as **non-responsive**.

25.2. The decision that bid is non-responsive for failure to provide the information required within the time specified shall be at the sole discretion of the City.

PERFORMANCE BOND, LABOR AND MATERIALMEN'S BOND

FAITHFUL PERFORMANCE BOND AND LABOR AND MATERIALMEN'S BOND:

Tri-Group Construction & Development, Inc., a corporation, as principal, and NORTH AMERICAN SPECIALTY INSURANCE COMPANY, a corporation authorized to do business in the State of California, as Surety, hereby obligate themselves, their successors and assigns, jointly and severally, to The City of San Diego a municipal corporation in the sum of Six Million Eight Hundred Thirty Four Thousand Dollars and Zero Cents (\$6,834,000.00) for the faithful performance of the annexed contract, and in the sum of Six Million Eight Hundred Thirty Four Thousand Dollars and Zero Cents (\$6,834,000.00) for the benefit of laborers and materialmen designated below.

Conditions:

If the Principal shall faithfully perform the annexed contract with the City of San Diego, California, then the obligation herein with respect to a faithful performance shall be void; otherwise it shall remain in full force.

If the Principal shall promptly pay all persons, firms and corporations furnishing materials for or performing labor in the execution of this contract, and shall pay all amounts due under the California Unemployment Insurance Act then the obligation herein with respect to laborers and materialmen shall be void; otherwise it shall remain in full force.

The obligation herein with respect to laborers and materialmen shall inure to the benefit of all persons, firms and corporations entitled to file claims under the provisions of Article 2. Claimants, (iii) public works of improvement commencing with Civil Code Section 9100 of the Civil Code of the State of California.

Changes in the terms of the annexed contract or specifications accompanying same or referred to therein shall not affect the Surety's obligation on this bond, and the Surety hereby waives notice of same.

The Surety shall pay reasonable attorney's fees should suit be brought to enforce the provisions of this bond.

The Surety expressly agrees that the City of San Diego may reject any contractor or subcontractor which may be proposed by Surety in fulfillment of its obligations in the event of default by the Principal.

The Surety shall not utilize the Principal in completing the improvements and work specified in the Agreement in the event the City terminates the Principal for default.

PERFORMANCE BOND, LABOR AND MATERIALMEN'S BOND (continued)

THE CITY OF SAN DIEGO

By 

Print Name: Cindy Crocker
Acting Deputy Director
Purchasing & Contracting Department

Date: 11/15/2021

APPROVED AS TO FORM

Mara W. Elliott, City Attorney

By 

Print Name: Dana Fardhib
Deputy City Attorney

Date: 11/16/2021

CONTRACTOR TRI-GROUP CONSTRUCTION
AND DEVELOPMENT, INC.

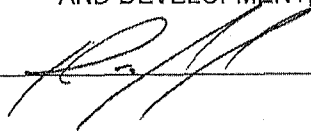
By: 

Print Name: HANI ASSI, SECRETARY

Date: NOVEMBER 5, 2021

SURETY NORTH AMERICAN
SPECIALTY INSURANCE COMPANY

By: 
Attorney-In-Fact

Print Name: MARK D. IATAROLA, ATTORNEY-IN-FACT

Date: NOVEMBER 5, 2021

777 SOUTH FIGUEROA STREET, SUITE 3700
LOS ANGELES, CA 90017

Local Address of Surety

800/338-0753

Local Phone Number of Surety

\$50,841.00
PREMIUM IS FOR CONTRACT TERM
AND IS SUBJECT TO ADJUSTMENT
BASED ON FINAL CONTRACT PRICE

Premium

2317676

Bond Number

CALIFORNIA ALL-PURPOSE ACKNOWLEDGMENT

CIVIL CODE § 1189

A notary public or other officer completing this certificate verifies only the identity of the individual who signed the document to which this certificate is attached, and not the truthfulness, accuracy, or validity of that document.

State of California }
County of SAN DIEGO }

On 11/5/2021 before me, TRACY LYNN RODRIGUEZ, NOTARY PUBLIC
Date Here Insert Name and Title of the Officer

personally appeared MARK D. IATAROLA
Name(s) of Signer(s)

who proved to me on the basis of satisfactory evidence to be the person(s) whose name(s) is/are subscribed to the within instrument and acknowledged to me that he/she/they executed the same in his/her/their authorized capacity(ies), and that by his/her/their signature(s) on the instrument the person(s), or the entity upon behalf of which the person(s) acted, executed the instrument.



I certify under PENALTY OF PERJURY under the laws of the State of California that the foregoing paragraph is true and correct.

WITNESS my hand and official seal.

Signature *Tracy Lynn Rodriguez*
Signature of Notary Public

Place Notary Seal and/or Stamp Above

OPTIONAL

Completing this information can deter alteration of the document or fraudulent reattachment of this form to an unintended document.

Description of Attached Document

Title or Type of Document: _____

Document Date: _____ Number of Pages: _____

Signer(s) Other Than Named Above: _____

Capacity(ies) Claimed by Signer(s)

Signer's Name: MARK D. IATAROLA

Signer's Name: _____

Corporate Officer – Title(s): _____

Corporate Officer – Title(s): _____

Partner – Limited General

Partner – Limited General

Individual Attorney in Fact

Individual Attorney in Fact

Trustee Guardian of Conservator

Trustee Guardian of Conservator

Other: _____

Other: _____

Signer is Representing: _____

Signer is Representing: _____

CALIFORNIA ALL-PURPOSE ACKNOWLEDGMENT

CIVIL CODE § 1189

A notary public or other officer completing this certificate verifies only the identity of the individual who signed the document to which this certificate is attached, and not the truthfulness, accuracy, or validity of that document.

State of California }
County of SAN DIEGO }

On 11/05/2021 before me, TRACY LYNN RODRIGUEZ, NOTARY PUBLIC
Date Here Insert Name and Title of the Officer
personally appeared HANI ASSI
Name(s) of Signer(s)

who proved to me on the basis of satisfactory evidence to be the person(s) whose name(s) is/are subscribed to the within instrument and acknowledged to me that he/she/they executed the same in his/her/their authorized capacity(ies), and that by his/her/their signature(s) on the instrument the person(s), or the entity upon behalf of which the person(s) acted, executed the instrument.

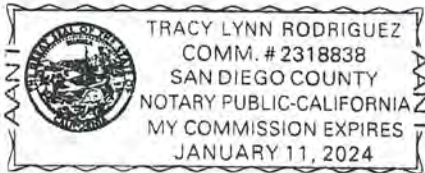

I certify under PENALTY OF PERJURY under the laws of the State of California that the foregoing paragraph is true and correct.

WITNESS my hand and official seal.

Place Notary Seal and/or Stamp Above

Signature *Tracy Lynn Rodriguez*
Signature of Notary Public

OPTIONAL

Completing this information can deter alteration of the document or fraudulent reattachment of this form to an unintended document.

Description of Attached Document

Title or Type of Document: _____

Document Date: _____ Number of Pages: _____

Signer(s) Other Than Named Above: _____

Capacity(ies) Claimed by Signer(s)

Signer's Name: HANI ASSI

Corporate Officer – Title(s): SECRETARY

Partner – Limited General

Individual Attorney in Fact

Trustee Guardian of Conservator

Other: _____

Signer is Representing: _____

Signer's Name: _____

Corporate Officer – Title(s): _____

Partner – Limited General

Individual Attorney in Fact

Trustee Guardian of Conservator

Other: _____

Signer is Representing: _____

SWISS RE CORPORATE SOLUTIONS

NORTH AMERICAN SPECIALTY INSURANCE COMPANY
WASHINGTON INTERNATIONAL INSURANCE COMPANY
WESTPORT INSURANCE CORPORATION

GENERAL POWER OF ATTORNEY

KNOW ALL MEN BY THESE PRESENTS, THAT North American Specialty Insurance Company, a corporation duly organized and existing under laws of the State of New Hampshire, and having its principal office in the City of Kansas City, Missouri and Washington International Insurance Company a corporation organized and existing under the laws of the State of New Hampshire and having its principal office in the City of Kansas City, Missouri, and Westport Insurance Corporation, organized under the laws of the State of Missouri, and having its principal office in the City of Kansas City, Missouri does hereby make, constitute and appoint:

JOHN G. MALONEY, HELEN MALONEY, SANDRA FIGUEROA, MARK D. IATAROLA, JESSICA SCHMAL
AND TRACY LYNN RODRIGUEZ JOINTLY OR SEVERALLY

Its true and lawful Attorney(s)-in-Fact, to make, execute, seal and deliver, for and on its behalf and as its act and deed, bonds or other writings obligatory in the nature of a bond on behalf of each of said Companies, as surety, on contracts of suretyship as are or may be required or permitted by law, regulation, contract or otherwise, provided that no bond or undertaking or contract or suretyship executed under this authority shall exceed the amount of:

ONE HUNDRED TWENTY FIVE MILLION (\$125,000,000.00) DOLLARS

This Power of Attorney is granted and is signed by facsimile under and by the authority of the following Resolutions adopted by the Boards of Directors of North American Specialty Insurance Company and Washington International Insurance Company at meetings duly called and held on March 24, 2000 and Westport Insurance Corporation by written consent of its Executive Committee dated July 18, 2011.

"RESOLVED, that any two of the President, any Senior Vice President, any Vice President, any Assistant Vice President, the Secretary or any Assistant Secretary be, and each or any of them hereby is authorized to execute a Power of Attorney qualifying the attorney named in the given Power of Attorney to execute on behalf of the Company bonds, undertakings and all contracts of surety, and that each or any of them hereby is authorized to attest to the execution of any such Power of Attorney and to attach therein the seal of the Company; and it is

FURTHER RESOLVED, that the signature of such officers and the seal of the Company may be affixed to any such Power of Attorney or to any certificate relating thereto by facsimile, and any such Power of Attorney or certificate bearing such facsimile signatures or facsimile seal shall be binding upon the Company when so affixed and in the future with regard to any bond, undertaking or contract of surety to which it is attached."



By [Signature]
Steven P. Anderson, Senior Vice President of Washington International Insurance Company
& Senior Vice President of North American Specialty Insurance Company
& Senior Vice President of Westport Insurance Corporation

By [Signature]
Mike A. Ito, Senior Vice President of Washington International Insurance Company
& Senior Vice President of North American Specialty Insurance Company
& Senior Vice President of Westport Insurance Corporation

IN WITNESS WHEREOF, North American Specialty Insurance Company, Washington International Insurance Company and Westport Insurance Corporation have caused their official seals to be hereunto affixed, and these presents to be signed by their authorized officers this 19TH day of JUNE, 20 19.

North American Specialty Insurance Company
Washington International Insurance Company
Westport Insurance Corporation

State of Illinois
County of Cook ss:

On this 19TH day of JUNE, 20 19, before me, a Notary Public personally appeared Steven P. Anderson, Senior Vice President of

Washington International Insurance Company and Senior Vice President of North American Specialty Insurance Company and Senior Vice President of Westport Insurance Corporation and Michael A. Ito Senior Vice President of Washington International Insurance Company and Senior Vice President

of North American Specialty Insurance Company and Senior Vice President of Westport Insurance Corporation, personally known to me, who being by me duly sworn, acknowledged that they signed the above Power of Attorney as officers of and acknowledged said instrument to be the voluntary act and deed of their respective companies.



[Signature]
M. Kenny, Notary Public

I, Jeffrey Goldberg, the duly elected Vice President and Assistant Secretary of North American Specialty Insurance Company, Washington International Insurance Company and Westport Insurance Corporation do hereby certify that the above and foregoing is a true and correct copy of a Power of Attorney given by said North American Specialty Insurance Company, Washington International Insurance Company and Westport Insurance Corporation which is still in full force and effect.

IN WITNESS WHEREOF, I have set my hand and affixed the seals of the Companies this 5TH day of NOVEMBER, 20 21.

[Signature]
Jeffrey Goldberg, Vice President & Assistant Secretary of Washington International Insurance Company & North American Specialty Insurance Company & Vice President & Assistant Secretary of Westport Insurance Corporation

ATTACHMENTS

ATTACHMENT A
SCOPE OF WORK

SCOPE OF WORK

1. **SCOPE OF WORK:** Wangenheim Neighborhood Park Joint Use Facility shall include, and not be limited to, demolition, grading, new grass fields, ball field, storm drain, water quality detention basin, snack bar/comfort station, sewer and water lateral and irrigation systems, shade sails to cover existing playground, retaining walls, parking lot, curb ramps, sidewalks, DG trail, sport lighting, fencing, backstops, and landscaping as specified in the Plans, Contract Documents, and Technicals Section.
 - 1.1 The Work shall be performed in accordance with:
 - 1.1.1. The Notice Inviting Bids and Plans numbered **40846-1-D** through **40846-142-D**, inclusive.
2. **LOCATION OF WORK:** The location of the Work is as follows:

See **Appendix E – Location Map**
3. **CONTRACT TIME:** The Contract Time for completion of the Work, including the Plant Establishment Period, shall be **288 Working Days**.

ATTACHMENT B
RESERVED

ATTACHMENT C
RESERVED

ATTACHMENT D
PREVAILING WAGE

PREVAILING WAGE

1. **PREVAILING WAGE RATES:** Pursuant to San Diego Municipal Code section 22.3019, construction, alteration, demolition, repair and maintenance work performed under this Contract is subject to State prevailing wage laws. For construction work performed under this Contract cumulatively exceeding \$25,000 and for alteration, demolition, repair and maintenance work performed under this Contract cumulatively exceeding \$15,000, the Contractor and its subcontractors shall comply with State prevailing wage laws including, but not limited to, the requirements listed below.
 - 1.1. **Compliance with Prevailing Wage Requirements.** Pursuant to sections 1720 through 1861 of the California Labor Code, the Contractor and its subcontractors shall ensure that all workers who perform work under this Contract are paid not less than the prevailing rate of per diem wages as determined by the Director of the California Department of Industrial Relations (DIR). This includes work performed during the design and preconstruction phases of construction including, but not limited to, inspection and land surveying work.
 - 1.1.1. Copies of such prevailing rate of per diem wages are on file at the City and are available for inspection to any interested party on request. Copies of the prevailing rate of per diem wages also may be found at <http://www.dir.ca.gov/OPRL/DPreWageDetermination.htm>. Contractor and its subcontractors shall post a copy of the prevailing rate of per diem wages determination at each job site and shall make them available to any interested party upon request.
 - 1.1.2. The wage rates determined by the DIR refer to expiration dates. If the published wage rate does not refer to a predetermined wage rate to be paid after the expiration date, then the published rate of wage shall be in effect for the life of this Contract. If the published wage rate refers to a predetermined wage rate to become effective upon expiration of the published wage rate and the predetermined wage rate is on file with the DIR, such predetermined wage rate shall become effective on the date following the expiration date and shall apply to this Contract in the same manner as if it had been published in said publication. If the predetermined wage rate refers to one or more additional expiration dates with additional predetermined wage rates, which expiration dates occur during the life of this Contract, each successive predetermined wage rate shall apply to this Contract on the date following the expiration date of the previous wage rate. If the last of such predetermined wage rates expires during the life of this Contract, such wage rate shall apply to the balance of the Contract.
 - 1.2. **Penalties for Violations.** Contractor and its subcontractors shall comply with California Labor Code section 1775 in the event a worker is paid less than the prevailing wage rate for the work or craft in which the worker is employed. This shall be in addition to any other applicable penalties allowed under Labor Code sections 1720 – 1861.

- 1.3. Payroll Records.** Contractor and its subcontractors shall comply with California Labor Code section 1776, which generally requires keeping accurate payroll records, verifying and certifying payroll records, and making them available for inspection. Contractor shall require its subcontractors to also comply with section 1776. Contractor and its subcontractors shall submit weekly certified payroll records online via the City's web-based Labor Compliance Program. Contractor is responsible for ensuring its subcontractors submit certified payroll records to the City.
- 1.3.1.** Contractor and their subcontractors shall also furnish records specified in Labor Code section 1776 directly to the Labor Commissioner in the manner required by Labor Code section 1771.4.
- 1.4. Apprentices.** Contractor and its subcontractors shall comply with California Labor Code sections 1777.5, 1777.6 and 1777.7 concerning the employment and wages of apprentices. Contractor is held responsible for the compliance of their subcontractors with sections 1777.5, 1777.6 and 1777.7.
- 1.5. Working Hours.** Contractor and their subcontractors shall comply with California Labor Code sections 1810 through 1815, including but not limited to: (i) restrict working hours on public works contracts to eight hours a day and forty hours a week, unless all hours worked in excess of 8 hours per day are compensated at not less than 1½ times the basic rate of pay; and (ii) specify penalties to be imposed on contractors and subcontractors of \$25 per worker per day for each day the worker works more than 8 hours per day and 40 hours per week in violation of California Labor Code sections 1810 through 1815.
- 1.6. Required Provisions for Subcontracts.** Contractor shall include at a minimum a copy of the following provisions in any contract they enter into with a subcontractor: California Labor Code sections 1771, 1771.1, 1775, 1776, 1777.5, 1810, 1813, 1815, 1860 and 1861.
- 1.7. Labor Code Section 1861 Certification.** Contractor in accordance with California Labor Code section 3700 is required to secure the payment of compensation of its employees and by signing this Contract, Contractor certifies that "I am aware of the provisions of Section 3700 of the California Labor Code which require every employer to be insured against liability for workers' compensation or to undertake self-insurance in accordance with the provisions of that code, and I will comply with such provisions before commencing the performance of the work of this Contract."
- 1.8. Labor Compliance Program.** The City has its own Labor Compliance Program authorized in August 2011 by the DIR. The City will withhold contract payments when payroll records are delinquent or deemed inadequate by the City or other governmental entity, or it has been established after an investigation by the City or other governmental entity that underpayment(s) have occurred. For questions or assistance, please contact the City of San Diego's Prevailing Wage Unit at 858-627-3200.
- 1.9. Contractor and Subcontractor Registration Requirements.** This project is subject to compliance monitoring and enforcement by the DIR. A contractor or subcontractor

shall not be qualified to bid on, be listed in a bid or proposal, subject to the requirements of section 4104 of the Public Contract Code, or engage in the performance of any contract for public work, unless currently registered and qualified to perform public work pursuant to Labor Code section 1725.5. It is not a violation of this section for an unregistered contractor to submit a bid that is authorized by Section 7029.1 of the Business and Professions code or by Section 10164 or 20103.5 of the Public Contract Code, provided the contractor is registered to perform public work pursuant to Section 1725.5 at the time the contract is awarded.

1.9.1. A Contractor's inadvertent error in listing a subcontractor who is not registered pursuant to Labor Code section 1725.5 in response to a solicitation shall not be grounds for filing a bid protest or grounds for considering the bid non-responsive provided that any of the following apply: (1) the subcontractor is registered prior to bid opening; (2) within twenty-four hours after the bid opening, the subcontractor is registered and has paid the penalty registration fee specified in Labor Code section 1725.5; or (3) the subcontractor is replaced by another registered subcontractor pursuant to Public Contract Code section 4107.

1.9.2. By submitting a bid or proposal to the City, Contractor is certifying that he or she has verified that all subcontractors used on this public work project are registered with the DIR in compliance with Labor Code sections 1771.1 and 1725.5, and Contractor shall provide proof of registration for themselves and all listed subcontractors to the City at the time of bid or proposal due date or upon request.

1.10. Stop Order. For Contractor or its subcontractors engaging in the performance of any public work contract without having been registered in violation of Labor Code sections 1725.5 or 1771.1, the Labor Commissioner shall issue and serve a stop order prohibiting the use of the unregistered contractors or unregistered subcontractor(s) on ALL public works until the unregistered contractor or unregistered subcontractor(s) is registered. Failure to observe a stop order is a misdemeanor.

1.11. List of all Subcontractors. The Contractor shall provide the list of subcontractors (regardless of tier), along with their DIR registration numbers, utilized on this Contract prior to any work being performed; and the Contractor shall provide a complete list of all subcontractors with each invoice. Additionally, Contractor shall provide the City with a complete list of all subcontractors (regardless of tier) utilized on this contract within ten working days of the completion of the contract, along with their DIR registration numbers. The City shall withhold final payment to Construction Management Professional until at least thirty (30) days after this information is provided to the City.

1.12. Exemptions for Small Projects. There are limited exemptions for installation, alteration, demolition, or repair work done on projects of \$25,000 or less. The Contractor shall still comply with Labor Code sections 1720 et. seq. The only recognized exemptions are listed below:

1.12.1. Registration. The Contractor will not be required to register with the DIR for small projects. (Labor Code section 1771.1).

- 1.12.2.** Certified Payroll Records. The records required in Labor Code section 1776 shall be required to be kept and submitted to the City of San Diego, but will not be required to be submitted online with the DIR directly. The Contractor will need to keep those records for at least three years following the completion of the Contract. (Labor Code section 1771.4).
- 1.12.3.** List of all Subcontractors. The Contractor shall not be required to hire only registered subcontractors and is exempt from submitting the list of all subcontractors that is required in section 1.11. above. (Labor code section 1773.3).

ATTACHMENT E
SUPPLEMENTARY SPECIAL PROVISIONS

SUPPLEMENTARY SPECIAL PROVISIONS

The following Supplementary Special Provisions (SSP) modifies the following documents:

1. The **2018 Edition** of the Standard Specifications for Public Works Construction (The "GREENBOOK").
2. The **2018 Edition** of the City of San Diego Standard Specifications for Public Works Construction (The "WHITEBOOK"), including the following:
 - a) General Provisions (A) for all Construction Contracts.

PART 0 – EQUAL OPPORTUNITY CONTRACTING PROGRAM (EOCP)

SECTION A – GENERAL REQUIREMENTS

0-12 CONTRACT RECORDS AND REPORTS. To the "WHITEBOOK", DELETE in its entirety and SUBSTITUTE with the following:

1. You shall maintain records of all subcontracts and invoices from your Subcontractors and Suppliers for work on this project. Records shall show name, telephone number including area code, and business address of each Subcontractor, Supplier, and joint venture partner, and the total amount actually paid to each firm. Project relevant records, regardless of tier, may be periodically reviewed by the City.
2. You shall retain all records, books, papers, and documents pertinent to the Contract for a period of not less than 5 years after Notice of Completion and allow access to said records by the City's authorized representatives.
3. You shall submit the following reports using the City's web-based contract compliance (Prism® portal):
 - a) **Monthly Payment.** You shall submit Monthly Payment Reporting by the 10th day of the subsequent month. Incomplete and/or delinquent reporting may cause payment delays, non-payment of invoices, or both.
4. The records maintained under item 1, described above, shall be consolidated into a Final Summary Report, certified as correct by an authorized representative of the Contractor. The Final Summary Report shall include all subcontracting activities and be sent to the EOCP Program Manager prior to Acceptance. Failure to comply may result in assessment of liquidated damages or withholding of retention. The City will review and verify 100% of subcontract participation reported in the Final Summary Report prior to approval and release of final retention to you. In the event your Subcontractors are owed money for completed Work, the City may authorize payment to subcontractor via a joint check from the withheld retention.

SECTION 1 – GENERAL, TERMS, DEFINITIONS, ABBREVIATIONS, UNITS OF MEASURE, AND SYMBOLS

1-2 TERMS AND DEFINITIONS. To the “WHITEBOOK”, items 43, 56, 69, and 102, DELETE in their entirety and SUBSTITUTE with the following:

- 43. **Field Order** -A Field Order is a written agreement by the Engineer to compensate you for Work items in accordance with 2-8, “EXTRA WORK” or 2-9, “CHANGED CONDITIONS”. A Field Order does not change the Contract Price, Contract Time, or the scope intent of the Contract. The unused portion of the Field Order shall revert to the City upon Acceptance.
- 56. **Notice of Completion (NOC)** - A document recorded with the County of San Diego to signify that the Contract Work has been completed and accepted by the City.
- 69. **Punchlist** - A list of items of Work or corrections generated after a Walk-through that is conducted when you consider that the Work and Services are complete, and as verified by the Owner. The Punchlist may be completed in phases if defined in the Contract.
- 102. **Walk-through**- An inspection the City uses to verify the completion of the Project or phase of the Project and to generate a Punchlist prior to Acceptance.

To the “WHITEBOOK”, item 54, “Normal Working Hours”, ADD the following:

The **Normal Working Hours** are **8:00 AM** to **5:00 PM**.

To the “WHITEBOOK”, ADD the following:

- 108. **Acceptance** – When all of the Contract Work, including all Punchlist items, is deemed officially complete by the City Asset Owning Department or Deputy City Engineer.
- 109. **Occupancy** – When the Owner deems a building is ready for use, the Owner will issue a certificate of Occupancy in writing.
- 110. **Substantial Completion** – When all Contract Work is deemed complete by the Contractor in writing, and as verified by the Owner. Substantial Completion may be completed in phases if defined in the Contract.

1-7.1.3 Requests for Information (RFI). To the “WHITEBOOK”, DELETE in its entirety and SUBSTITUTE with the following:

- 1. Should You discover a conflict, omission, errors in the Contract Documents, differences with existing field conditions, or have any questions concerning interpretation or clarification of Contract Documents, or when you propose deviations to the standards or design, you shall submit a Request for Information (RFI) to the City regarding your question or clarification within **1 Working Day**.
- 2. Your RFI shall meet the following requirements:

- a) All RFIs, whether by You or your Subcontractor or supplier at any tier, shall be submitted by You to the City.
 - b) RFIs shall be numbered sequentially.
 - c) You shall clearly and concisely set forth the single issue for which interpretation or clarification is sought, indicate Specification Section numbers, Contract Drawing numbers, and details, or other items involved, and state why a response is required from the City.
 - d) RFIs shall be submitted within **1 Working Day** in order that they may be adequately researched and answered before the response affects any critical activity of the Work.
 - e) Should You believe that a response to an RFI causes a change to the requirements of the Contract, You shall, before proceeding, give written notice to the City, indicating that You believe that City response to the RFI to be a Change Order. Failure to give such written notice within **5 Working Days** of receipt of the City's response to the RFI shall waive Your right to seek additional time or cost.
3. The City will respond to RFIs within **5 Working Days** unless the City notifies You in writing that a response will take longer. The **5 Working Days** shall begin when the RFI is received and dated by the City. Responses from the City will not change any requirement of the Contract unless so noted by the City in the response to the RFI. The City will not issue a Change Order for Extra Work or additional time when the issue raised in the RFI was due to your fault, neglect, or any unauthorized deviations from the project design or specifications.
4. If You proceed in resolving a conflict, omission, or any error in the Contract Documents without sending the City an RFI in accordance with the requirements stated above, the City may require You to remove such work at Your cost or back charge You the cost to remove this work.

1-7.2 Contract Bonds. To the "WHITEBOOK", item 1, DELETE in its entirety and SUBSTITUTE with the following:

- 1. Before execution of the Contract, file payment and performance bonds with the City to be approved by the Board in the amounts and for the purposes noted. Bonds shall be executed by a responsible surety as follows:
 - a) If the Work is being funded with state or local money, consistent with California Code of Civil Procedure §995.670, the Surety shall be an "admitted surety" authorized by the State of California Department of Insurance to transact surety insurance in the State.
 - b) If the Work is being funded with federal money, the Surety shall be listed in the U.S. Treasury Department Circular 570 and shall be in conformance with the specified Underwriting Limitations.

To the "WHITEBOOK", item 2, subsection "a", subsection "i", DELETE in its entirety and SUBSTITUTE with the following:

- i. A "Payment Bond" (Materials and Labor Bond) is optional. If no bond is submitted, no payment shall be made until 35 Calendar Days after Acceptance and any lien requirements have been fulfilled. If a bond is submitted, progress payments shall be made in accordance with these Specifications.

To the "WHITEBOOK", item 2, subsection "d", DELETE in its entirety and SUBSTITUTE with the following:

- d) For Contracts over \$100,000:
 - i. A "Payment Bond" (Materials and Labor Bond) for 100% of the Contract Price to satisfy claims of material Suppliers and of mechanics and laborers employed on the Work. You shall maintain the bond in full force and effect until Acceptance and until all claims for materials and labor are paid and shall otherwise comply with the Government Code.
 - ii. A "Faithful Performance Bond" for 100% of the Contract Price to guarantee faithful performance of Work, within the time prescribed and in a manner satisfactory to the City, that materials and workmanship shall be free from original or developed defects.

To the "WHITEBOOK", item 7, DELETE in its entirety and SUBSTITUTE with the following:

7. You shall require the Surety to mail its standard "Bond Status" form to the Engineer at the following address:

Deputy Director
Construction Management and Field Engineering Division
9573 Chesapeake Drive San Diego, CA 92123

SECTION 2 - SCOPE OF THE WORK

2-2 PERMITS, FEES, AND NOTICES. To the "WHITEBOOK", ADD the following:

2. The City will obtain, at no cost to you, the following permits:
 - a) Building Permit

SECTION 3 - CONTROL OF THE WORK

3-2 SELF-PERFORMANCE. To the "GREENBOOK", DELETE in its entirety and SUBSTITUTE with the following:

1. You shall perform, with your own organization, Contract Work amounting to at least 50% of the base Bid.

3-3 SUBCONTRACTORS. To the "WHITEBOOK", ADD the following:

6. When a Subcontractor fails to prosecute a portion of the Work in a manner satisfactory to the City, you shall remove such Subcontractor immediately upon written request of the City, and shall request approval of a replacement Subcontractor to perform the Work in accordance with California Public Contract Code (PCC), Subletting and Subcontracting, Section 4107, at no added cost to the City.

3-9 TECHNICAL STUDIES AND SUBSURFACE DATA. To the “WHITEBOOK”, ADD the following:

5. In preparation of the Contract Documents, the designer has relied upon the following reports of explorations and tests at the Work Site:
 - a) Report of Geotechnical Investigation, dated February 7, 2017 by Allied Geotechnical Engineers, Inc.
 - b) Drainage Study (Revised), dated January 25, 2019, by Rick Engineering Co.
6. The reports listed above are available for review at the following link:
<https://filecloud.sandiego.gov/url/wangenheimneighborhoodpark>

3-10 SURVEYING. To the “GREENBOOK” and “WHITEBOOK”, DELETE in its entirety and SUBSTITUTE with the following:

3-10 SURVEYING (DESIGN-BID-BUILD).

3-10.1 General.

1. You shall provide all required site layout and general grade checking work not specified in 3-10.2, “Survey Services Provided by City (via City Consultant Surveyor)”.
2. Notify the City, in writing, at least 2 Working Days prior to requesting survey services provided by the City.

3-10.2 Survey Services Provided by City (via City Consultant Surveyor).

1. Monument Perpetuation, including mark-outs, will be performed by the City Engineering Support & Technical Services Division’s (ESTS), Land Survey Section (LSS), unless otherwise noted. You are responsible for requesting the coordination of these services.
 - a) If at any time a monument will be destroyed or covered, such monument shall be perpetuated in accordance with state law. Inform the LSS, via project Resident Engineer, if any monument will be destroyed or covered during any construction activity.
2. The following surveying services (including construction staking), as defined in California Business & Professions Code §8726, shall be provided by the City or a City consultant surveyor:
 - a) Locating or establishing alignment or elevations of all features or structures shown on project Plans.
 - b) Locating or establishing geodetic control points for all site feature or structure locations.
 - c) Produce topographic as-built data.
 - d) Locating, establishing, or re-establishing monuments, property lines, right-of-way lines, or easement lines.

- e) Verifying structure finish grade elevations.
- 3. All construction survey stakes, control points, and other survey related marks provided by the City shall be preserved for the duration of the Project. If any construction survey stakes, control points, or other survey related marks are lost or disturbed and need to be replaced, such replacement shall be performed at the your expense.

3-10.3 Payment.

- 1. The payment for site layout and general grade checking Work, coordination, and preservation of all survey related marks shall be included in the Contract Price.

3-13.1 Completion. To the "GREENBOOK", DELETE in its entirety and SUBSTITUTE with the following:

- 1. You shall submit a written assertion that the Work has been completed and is ready for Owner Acceptance. If, in the Engineer's judgment, the Work has been completed in accordance with the Contract Documents, the Engineer will set forth in writing the date the Work was completed. This will be the date that you are relieved from responsibility to protect and maintain the Work and to which liquidated damages will be computed.

3-13.1.1 Requirements Before Requesting a Walk-through. To the "WHITEBOOK", DELETE in its entirety and SUBSTITUTE with the following:

3-13.1.1 Requirements Before Requesting Substantial Completion.

- 1. The following items are required prior to requesting a Substantial Completion:
 - a) Remove temporary facilities from the Site.
 - b) Thoroughly cleaning the Site and removing all mark outs and construction staking.
 - c) Provide completed and signed Red-lines in accordance with 3-7.3 "Redlines and Record Documents".
 - d) Provide all material and equipment maintenance and operation instructions and/or manuals.
 - e) Provide all tools which are permanent parts of the equipment installed in the Project.
 - f) Provide and properly identify all keys for construction and all keys for permanent Work.
 - g) Provide all final Special Inspection reports required by the applicable building Code.
 - h) Provide all items specified to be supplied as extra stock. Wrap, seal, or place in a container all items as necessary to allow for storage by the City for future use. Verify the specified quantities.

- i) Ensure that all specified EOCP and certified wage rate documentations covering the Contract Time have been submitted.
- j) If the Work includes installing an irrigation system, provide the spare parts for the proposed irrigation system as specified in the Special Provisions.
- k) If the Work includes sewer and storm drain installations, the inspection shall include televising in accordance with 306-18, "VIDEO INSPECTION".
- l) If the Work includes a Plant Establishment Period, Work in accordance with 801-6, "MAINTENANCE AND PLANT ESTABLISHMENT" shall be completed prior to requesting Substantial Completion, unless approved otherwise by the Owner.
- m) Notify the Engineer to arrange a final inspection of any permanent BMPs installed.

3-13.1.2 Walk-through and Punchlist Procedure. To the "WHITEBOOK", DELETE in its entirety and SUBSTITUTE with the following:

1. You shall notify the Engineer 15 Working Days in advance of date of anticipated Substantial Completion to allow time for Engineer to schedule a Walk-through. After you complete the requirements in 3-13.1.1, "Requirements Before Requesting Substantial Completion" and when you consider that the Work is Substantially Complete, you will notify the Engineer in writing that the Project is Substantially Complete. The Engineer will review your request and determine if the Project is ready for a Walk-through, by verifying whether you have completed all items as required by 3-13.1.1, "Requirements Before Requesting Substantial Completion". Within 7 Working Days, the City will either reject your request of a Walk-through in writing or schedule a Walk-through inspection. The Engineer shall facilitate the Walk-through.
2. The following documents shall be provided at the time of your Walk-through request: As-Built markup, Plans, specifications, technical data such as submittals and equipment manuals, draft final payment, warranties, material certifications, bonds, guarantees, maintenance service agreements, and maintenance and operating manuals.
3. Written warranties, except manufacturer's standard printed warranties, shall be on a letterhead addressed to you. Warranties shall be submitted in the format described in this section, modified as approved by the City, to suit the conditions pertaining to the warranty. Lack of submitting these items will delay start of Walk-through.
4. The Engineer will provide you with the Punchlist within 15 Working Days after the date of the Walk-through. The City shall not provide a preliminary Punchlist.
5. If the Engineer finds that the Project is not Substantially Complete as defined herein, the Engineer will terminate the Walk-through and notify you in writing.

6. If, at any time during the Engineer's evaluation of the corrective Work required by the Punchlist, the Engineer discovers that additional corrective Work is required, the Engineer may include that corrective Work in the Punchlist.
7. You shall remain solely responsible for the Project Site until the Project is completely operational, all Punchlist items have been corrected, and all operation and maintenance manuals have been accepted by the City.
8. The Engineer shall meet with you within 5 Working Days of notification that all Punchlist items are corrected. You shall complete the Punchlist within 30 Working Days, and Working Days will continue to be counted until Acceptance of the Project.

3-13.2 Acceptance. To the "WHITEBOOK", DELETE in its entirety and SUBSTITUTE with the following:

1. You shall provide the completed, signed, and stamped DS-563 to the Engineer prior to Acceptance.
2. You shall deliver the final As-builts and final billing prior to Acceptance.
3. You shall assemble and deliver to the Engineer a Final Summary Report and Affidavit of Disposal prior to Acceptance.
4. Acceptance shall occur after all of the requirements contained in the Contract Documents have been fulfilled. If, in the Engineer's judgment, you have fully performed the Contract, the Engineer will recommend to the City Engineer that your performance of the Contract be accepted. You shall receive notification of Acceptance in writing from the Owner and counting of working days shall cease and Warranty begins.
5. Retention can be released 35 Calendar Days after NOC. Submit your request for retention to the Resident Engineer and they will mail to you a "Release of Claims" form which shall be completed and returned before the retention will be released.

3-13.3 Warranty. To the "WHITEBOOK", DELETE in its entirety and SUBSTITUTE with the following:

1. You shall warranty and repair all defective materials and workmanship for a period of 1 year. This call back warranty period shall start on the date the Work was accepted by the City unless the City has Beneficial Use or takes Occupancy of the project earlier (excluding water, sewer, and storm drain projects).
2. You shall warranty the Work free from all latent defects for 10 years and patent defects for a period of 4 years.
3. The warranty period for specific items covered under manufacturers' or suppliers' warranties shall commence on the date they are placed into service at the direction of the Engineer in writing.
4. All express warranties from Subcontractors, manufacturers', or Suppliers', of any tier, for the materials furnished and Work performed shall be assigned, in

writing, to the City, and shall be delivered to the Engineer prior to the Acceptance of your performance of the Contract.

5. Replace or repair defective materials and workmanship in a manner satisfactory to the Engineer after notice to do so from the Engineer and within the time specified in the notice. If you fail to make such replacements or repairs within the time specified in the notice, the City may perform the replacement or repairs at your expense. If you fail to reimburse the City for the actual costs, your Surety shall be liable for the cost
6. Items that shall be warranted free from defective workmanship and materials for a period longer than 1 year are as follows:

Specified Item	Minimum Warranty Period
Detectable Warning Tile Construction	3 Years of Manufacturer's Warranty
All Work Under SECTION 500 - PIPELINE REHABILITATION	3 Years
Fiber Optic Interconnect Cables	2 Years
Luminaires*	10 Years of Manufacturer's Warranty
LED Signal Modules	3 Years of Manufacturer's Warranty
Field Devices Associated with 700-6.3, "Adaptive Control Note"	See 700-6.3.9, "Warranty"

* Provide documentation verifying that the induction luminaire models being offered for the Project are covered by the 10 year warranty.

7. If installed, you shall provide the City and property owner a copy of the manufacturer's warranty for private sewer pumps, including the alarm panel and all other accessories.
 - a) You shall involve the manufacturer in the installation and startup as needed to secure any extended warranty required.
 - b) Nothing in here is intended to limit any manufacturer's warranty which provides the City with greater warranty rights than set forth in this section or the Contract Documents.
 - c) The warranty shall include all components. The form of the warranty shall be approved by the Engineer in accordance with 3-13.3.2, "Warranty Format Requirements".
8. If, during the warranty period, any item of the Work is found to be Defective Work, you shall correct it promptly after receipt of written notice from the City to do so. The warranty period shall be extended with respect to portions of the Work corrected as part of the warranty requirements.

3-15.3 Coordination. To the "WHITEBOOK", ADD the following:

2. Other adjacent projects are scheduled for construction for the same time period in the vicinity of this project. See **Appendix F - Adjacent Projects Map** for the approximate location. Coordinate the Work with the adjacent project.

SECTION 4 - CONTROL OF MATERIALS

4-3.6 Preapproved Materials. To the "WHITEBOOK", ADD the following:

3. You shall submit in writing a list of all products to be incorporated in the Work that are on the AML.

4-6 TRADE NAMES. To the "WHITEBOOK", ADD the following:

11. You shall submit your list of proposed substitutions for an "equal" item **no later than 5 Working Days after the determination of the Apparent Low Bidder** and on the City's Product Submittal Form available at:

<https://www.sandiego.gov/ecp/edocref/>

SECTION 5 - LEGAL RELATIONS AND RESPONSIBILITIES

5-4 INSURANCE. To the "GREENBOOK", DELETE in its entirety and SUBSTITUTE with the following:

5-4 INSURANCE.

1. The insurance provisions herein shall not be construed to limit your indemnity obligations contained in the Contract.

5-4.1 Policies and Procedures.

1. You shall procure the insurance described below, at its sole cost and expense, to provide coverage against claims for loss including injuries to persons or damage to property, which may arise out of or in connection with the performance of the Work by you, your agents, representatives, officers, employees or Subcontractors.
2. Insurance coverage for property damage resulting from your operations is on a replacement cost valuation. The market value will not be accepted.
3. You shall maintain this insurance for the duration of this Contract and at all times thereafter when you are correcting, removing, or replacing Work in accordance with this Contract. Your liabilities under the Contract, e.g., your indemnity obligations, is not deemed limited to the insurance coverage required by this Contract.
4. The payment for insurance shall be included in the Contract Price as bid by you. Except as specifically agreed to by the City in writing, you are not entitled to any additional payment. Do not begin any Work under this Contract until you have provided and the City has approved all required insurance.

5. Policies of insurance shall provide that the City is entitled to 30 Days (10 Days for cancellation due to non-payment of premium) prior written notice of cancellation or non-renewal of the policy. Maintenance of specified insurance coverage is a material element of the Contract. Your failure to maintain or renew coverage or to provide evidence of renewal during the term of the Contract may be treated by the City as a material breach of the Contract.

5-4.2 Types of Insurance.

5-4.2.1 Commercial General Liability Insurance.

1. Commercial General Liability Insurance shall be written on the current version of the ISO Occurrence form CG 00 01 07 98 or an equivalent form providing coverage at least as broad.
2. The policy shall cover liability arising from premises and operations, XCU (explosions, underground, and collapse), independent contractors, products/completed operations, personal injury and advertising injury, bodily injury, property damage, and liability assumed under an insured's contract (including the tort liability of another assumed in a business contract).
3. There shall be no endorsement or modification limiting the scope of coverage for either "insured vs. insured" claims or contractual liability. You shall maintain the same or equivalent insurance for at least 10 years following completion of the Work.
4. All costs of defense shall be outside the policy limits. Policy coverage shall be in liability limits of not less than the following:

<u>General Annual Aggregate Limit</u>	<u>Limits of Liability</u>
Other than Products/Completed Operations	\$2,000,000
Products/Completed Operations Aggregate Limit	\$2,000,000
Personal Injury Limit	\$1,000,000
Each Occurrence	\$1,000,000

5-4.2.2 Commercial Automobile Liability Insurance.

1. You shall provide a policy or policies of Commercial Automobile Liability Insurance written on the current version of the ISO form CA 00 01 12 90 or later version or equivalent form providing coverage at least as broad in the amount of \$1,000,000 combined single limit per accident, covering bodily injury and property damage for owned, non-owned, and hired automobiles ("Any Auto").
2. All costs of defense shall be outside the limits of the policy.

5-4.2.5 Contractors Builders Risk Property Insurance.

1. You shall provide at your expense, and maintain until Final Acceptance of the Work, a Special Form Builders Risk Policy or Policies. This insurance shall be in an amount equal to the replacement cost of the completed Work (without deduction for depreciation) including the cost of excavations, grading, and filling. The policy or policies limits shall be 100% of this Contract value of the Work plus

15% to cover administrative costs, design costs, and the costs of inspections and construction management.

2. Insured property shall include material or portions of the Work located away from the Site but intended for use at the Site and shall cover material or portions of the Work in transit. The policy or policies shall include as insured property scaffolding, falsework, and temporary buildings located at the Site. The policy or policies shall cover the cost of removing debris, including demolition.
3. The policy or policies shall provide that all proceeds thereunder shall be payable to the City as Trustee for the insured, and shall name the City, the Contractor, Subcontractors, and Suppliers of all tiers as named insured. The City, as Trustee, will collect, adjust, and receive all monies which may become due and payable under the policy or policies, may compromise any and all claims thereunder, and will apply the proceeds of such insurance to the repair, reconstruction, or replacement of the Work.
4. Any deductible applicable to the insurance shall be identified in the policy or policies documents and responsibility for paying the part of any loss not covered because of the application of such deductibles shall be apportioned among the parties except for the City as follows: if there is more than one claimant for a single occurrence, then each claimant shall pay a pro-rata share of the per occurrence deductible based upon the percentage of their paid claim to the total paid for insured. The City shall be entitled to 100% of its loss. You shall pay the City any portion of that loss not covered because of a deductible at the same time the proceeds of the insurance are paid to the City as trustee.
5. Any insured, other than the City, making claim to which a deductible applies shall be responsible for 100% of the loss not insured because of the deductible. Except as provided for under California law, the policy or policies shall provide that the City is entitled to 30 Days prior written notice (10 Days for cancellation due to non-payment of premium) of cancellation or non-renewal of the policy or policies.

5-4.3 Rating Requirements. Except for the State Compensation Insurance Fund, all insurance required by this Contract as described herein shall be carried only by responsible insurance companies with a rating of, or equivalent to, at least "A-, VI" by A.M. Best Company, that are authorized by the California Insurance Commissioner to do business in the State, and that have been approved by the City.

5-4.3.1 Non-Admitted Carriers. The City will accept insurance provided by non-admitted, "surplus lines" carriers only if the carrier is authorized to do business in the State and is included on the List of Approved Surplus Lines Insurers (LASLI list).

All policies of insurance carried by non-admitted carriers shall be subject to all of the requirements for policies of insurance provided by admitted carriers described herein.

5-4.4 Evidence of Insurance. Furnish to the City documents e.g., certificates of insurance and endorsements evidencing the insurance required herein, and furnish renewal documentation prior to expiration of this insurance. Each required document shall be signed by the insurer or a person authorized by the insurer to bind coverage on its

behalf. We reserve the right to require complete, certified copies of all insurance policies required herein.

5-4.5 Policy Endorsements.

5-4.5.1 Commercial General Liability Insurance.

5-4.5.1.1 Additional Insured.

1. You shall provide at your expense policy endorsement written on the current version of the ISO Occurrence form CG 20 10 11 85 or an equivalent form providing coverage at least as broad.
2. To the fullest extent allowed by law e.g., California Insurance Code §11580.04, the policy shall be endorsed to include the City and its respective elected officials, officers, employees, agents, and representatives as additional insured.
3. The additional insured coverage for projects for which the Engineer's Estimate is \$1,000,000 or more shall include liability arising out of:
 - a) Ongoing operations performed by you or on your behalf,
 - b) your products,
 - c) your Work, e.g., your completed operations performed by you or on your behalf, or
 - d) premises owned, leased, controlled, or used by you.
4. The additional insured coverage for projects for which the Engineer's Estimate is less than \$1,000,000 shall include liability arising out of:
 - a) Ongoing operations performed by you or on your behalf,
 - b) your products, or
 - c) premises owned, leased, controlled, or used by you.

5-4.5.1.2 Primary and Non-Contributory Coverage. The policy shall be endorsed to provide that the coverage with respect to operations, including the completed operations, if appropriate, of the Named Insured is primary to any insurance or self-insurance of the City and its elected officials, officers, employees, agents and representatives. Further, it shall provide that any insurance maintained by the City and its elected officials, officers, employees, agents and representatives shall be in excess of your insurance and shall not contribute to it.

5-4.5.1.3 Project General Aggregate Limit. The policy or policies shall be endorsed to provide a Designated Construction Project General Aggregate Limit that will apply only to the Work. Only claims payments which arise from the Work shall reduce the Designated Construction Project General Aggregate Limit. The Designated Construction Project General Aggregate Limit shall be in addition to the aggregate limit provided for the products-completed operations hazard.

5-4.5.2 Commercial Automobile Liability Insurance.

5-4.5.2.1 Additional Insured. Unless the policy or policies of Commercial Auto Liability Insurance are written on an ISO form CA 00 01 12 90 or a later version of this form or equivalent form providing coverage at least as broad, the policy shall be endorsed to include the City and its respective elected officials, officers, employees, agents, and representatives as additional insured, with respect to liability arising out of automobiles owned, leased, hired or borrowed by you or on your behalf. This endorsement is limited to the obligations permitted by California Insurance Code §11580.04.

5-4.5.5 Builders Risk Endorsements.

5-4.5.5.1 Waiver of Subrogation. The policy or policies shall be endorsed to provide that the insurer will waive all rights of subrogation against the City, and its respective elected officials, officers, employees, agents, and representatives for losses paid under the terms of the policy or policies and which arise from Work performed by the Named Insured for the City.

5-4.5.5.2 Builders Risk – Partial Utilization. If the City desires to occupy or use a portion or portions of the Work prior to Acceptance in accordance with this Contract, the City will notify you and you shall immediately notify your Builder's Risk insurer and obtain an endorsement that the policy or policies shall not be cancelled or lapse on account of any such partial use or occupancy. You shall obtain the endorsement prior to the City's occupation and use.

5-4.6 Deductibles and Self-Insured Retentions. You shall pay for all deductibles and self-insured retentions. You shall disclose deductibles and self-insured retentions to the City at the time the evidence of insurance is provided.

5-4.7 Reservation of Rights. The City reserves the right, from time to time, to review your insurance coverage, limits, deductibles and self-insured retentions to determine if they are acceptable to the City. The City will reimburse you, without overhead, profit, or any other markup, for the cost of additional premium for any coverage requested by the Engineer but not required by this Contract.

5-4.8 Notice of Changes to Insurance. You shall notify the City 30 Days prior to any material change to the policies of insurance provided under this Contract.

5-4.9 Excess Insurance. Policies providing excess coverage shall follow the form of the primary policy or policies e.g., all endorsements.

5-4.10 Architects and Engineers Professional Insurance (Errors and Omissions Insurance).

1. For Contracts with required engineering services (e.g., Design-Build, preparation of engineered Traffic Control Plans (TCP), and etc) by you, you shall keep or require all of your employees or Subcontractors, who provide professional engineering services under this contract, Professional Liability

coverage with a limit of **\$1,000,000** per claim and **\$2,000,000** annual aggregate in full force and effect.

2. You shall ensure the following:
 - a) The policy retroactive date is on or before the date of commencement of the Project.
 - b) The policy will be maintained in force for a period of 3 years after completion of the Project or termination of this Contract, whichever occurs last. You agree that for the time period specified above, there will be no changes or endorsements to the policy that affect the specified coverage.
3. If professional engineering services are to be provided solely by the Subcontractor, you shall:
 - a) Certify this to the City in writing and
 - b) Agree in writing to require the Subcontractor to procure Professional Liability coverage in accordance with the requirements set forth above.

5-4.11 Workers' Compensation Insurance and Employers Liability Insurance.

1. In accordance with the provisions of §3700 of the California Labor Code, you shall provide at your expense Workers' Compensation Insurance and Employers Liability Insurance to protect you against all claims under applicable state workers compensation laws. The City, its elected officials, and employees will not be responsible for any claims in law or equity occasioned by your failure to comply with the requirements of this section.
2. Limits for this insurance shall be not less than the following:

<u>Workers' Compensation</u>	<u>Statutory Employers Liability</u>
Bodily Injury by Accident	\$1,000,000 each accident
Bodily Injury by Disease	\$1,000,000 each employee
Bodily Injury by Disease	\$1,000,000 policy limit
3. By signing and returning the Contract you certify that you are aware of the provisions of §3700 of the Labor Code which requires every employer to be insured against liability for worker's compensation or to undertake self-insurance in accordance with the provisions of that code and you shall comply with such provisions before commencing the Work as required by §1861 of the California Labor Code.

5-4.11.1 Waiver of Subrogation. The policy or policies shall be endorsed to provide that the insurer will waive all rights of subrogation against the City and its respective elected officials, officers, employees, agents, and representatives for losses paid under the terms of the policy or policies and which arise from Work performed by the Named Insured for the City.

5-13

ELECTRONIC COMMUNICATION. To the "WHITEBOOK", DELETE in its entirety and SUBSTITUTE with the following:

1. Virtual Project Manager shall be used on this Contract.
2. You shall post all communications addressed to the Engineer concerning construction including RFIs, submittals, daily logs including the Weekly Statement of Working Days (WSWD), Storm Water, and transmittals to the Virtual Project Manager (VPM) website established for the Projects. This shall not supersede any Federal requirements.
3. Maintain a list of scheduled activities including planned and actual execution dates for all major construction activities and milestones defined in the approved Schedule.
4. Review and act on all communications addressed to you in the VPM project website.
5. A user's guide to the VPM system is available on the City's website and shall be provided to you at the Pre-construction Meeting. Refer to the VPM training videos and forms at the location below:
<https://www.sandiego.gov/ecp/edocref/>
6. Submit the Sensitive Information Authorization Acknowledgement Form and VPM User Agreement located in the VPM user's guide at the Pre-construction Meeting.

5-15.1

General. To the "WHITEBOOK", item 10, DELETE in its entirety and SUBSTITUTE with the following:

10. If your construction activities have encountered flammable liquids or other hazardous substances, you shall ensure that construction staff have the required Hazardous Waste Operations and Emergency Response (HAZWOPER) certification. Construction staff shall include: City Engineers, City Laboratory Technicians, and City staff that perform onsite inspections.
 - a) If your Work encounters flammable liquids or other hazardous substances, you shall be responsible for scheduling training for all construction staff to attend and for submitting verification to the Engineer that construction staff have the required HAZWOPER certification prior to continuing that Work in that area. You shall maintain the HAZWOPER certifications annually until the construction activities triggering the requirement is complete, as approved by the Resident Engineer.

SECTION 6 – PROSECUTION AND PROGRESS OF THE WORK

6-1.1 Construction Schedule. To the “WHITEBOOK”, item 1, subsection “e” and “s”, DELETE in its entirety and SUBSTITUTE with the following:

- e) Monthly progress payments are contingent upon the submittal of an updated Schedule to the Engineer. The Engineer may refuse to process the whole or part of any monthly payment if you refuse or fail to provide an acceptable schedule.
- s) Submit an updated cash flow forecast with every pay request (for each Project ID or WBS number provided in the Contract) showing periodic and cumulative construction billing amounts for the duration of the Contract Time. If there has been any Extra Work since the last update, include only the approved amounts.
 - i. Refer to the Sample City Invoice materials in **Appendix D – Sample City Invoice with Cash Flow Forecast** and use the format shown.
 - ii. See also the “Cash Flow Forecast Example” at the location below:
<https://www.sandiego.gov/ecp/edocref/>

To the “WHITEBOOK”, ADD the following:

- 3. The **90 Calendar Day** Plant Establishment Period is included in the stipulated Contract Time and shall begin with the acceptance of installation of the vegetation plan in accordance with Section 801-6, “MAINTENANCE AND PLANT ESTABLISHMENT”.

6-1.5.2 Excusable Non-Compensable Delays. To the “WHITEBOOK”, DELETE in its entirety and SUBSTITUTE with the following:

6-1.5.2 Excusable Non-Compensable and Concurrent Delays.

- 1. The City shall only issue an extension of time for Excusable Delays that meet the requirements of 6-4.2, “Extensions of Time” for the following circumstances:
 - a) Delays resulting from Force Majeure.
 - b) Delays caused by weather.
 - c) Delays caused by changes to County, State, or Federal law.
- 2. When a non-excusable delay is concurrent with an Excusable Delay, you shall not be entitled to an extension of Contract Time for the period the non-excusable delay is concurrent with the Excusable Delay.
- 3. When an Excusable Non-Compensable Delay is concurrent with an Excusable Compensable Delay, you shall be entitled to an extension of Contract Time, but shall not be entitled to compensation for the period the Excusable Non-Compensable Delay is concurrent with the Excusable Compensable Delay.

6-4.2

Extensions of Time. To the "WHITEBOOK", DELETE in its entirety and SUBSTITUTE with the following:

1. The Contract Time shall not be modified except by Change Order.
2. You shall notify the City in writing within **1 Working Day** after the occurrence and discovery of an event that impacts the Project Schedule.
 - a) If you believe this event requires a Change Order, you shall submit a written Change Order request with a report to the City that explains the request for Change Order within **5 Working Days**. The Change Order request must include supporting data, a general description of the discovery, the basis for extension, and the estimated length of extension. The City may grant an extension of time, in writing, for the Change Order request if you require more time to gather and analyze data.
3. The Engineer shall not grant an extension of Contract Time in accordance with 6-1.5, "Excusable Delays" unless you demonstrate, through an analysis of the critical path, the following:
 - a) The event causing the delay impacted the activities along the Project's critical path.
 - b) The increases in the time to perform all or part of the Project beyond the Contract Time arose from unforeseeable causes beyond your control and without your fault or negligence and that all project float has been used.
4. Any modifications to the Contract Time will be incorporated into the weekly document that the Engineer issues that stipulates the Contract Time. If you do not agree with this document, submit to the Engineer for review a written protest supporting your objections to the document within **30 Calendar Days** after receipt of the statement. Your failure to file a timely protest shall constitute your acceptance of the Engineer's weekly document.
 - a) Your protest will be considered a claim for time extension and shall be subject to 2-10.1, "Claims".

6-4.4

Written Notice and Report. To the "WHITEBOOK", DELETE in its entirety and SUBSTITUTE with the following:

1. Your failure to notify the Resident Engineer within **1 Working Day** OR provide a Change Order request within **5 Working Days** after the event, in accordance with 6-4.2, "Extensions of Time", will be considered grounds for refusal by the City to consider such request if your failure to notify prejudices the City in responding to the event.

ADD:

6-6.1.1 Environmental Document.

1. The City of San Diego has prepared a **Notice of Exemption** for **Wangenheim Joint Use Facility, Project No. 616806/5 – 5-15007.02.06**, as referenced in the Contract Appendix. You shall comply with all requirements of the **Notice of Exemption** as set forth in **Appendix A**.
2. Compliance with the City's environmental document shall be included in the Contract Price.

SECTION 7 – MEASUREMENT AND PAYMENT

7-3.1 General. To the "GREENBOOK" and "WHITEBOOK", paragraph (8), DELETE in its entirety and SUBSTITUTE with the following:

If, within the time fixed by law, a properly executed notice to stop payment is filed with the City, due to your failure to pay for labor or materials used in the Work, all money due for such labor or materials will be withheld from payment in accordance with applicable laws.

To the "WHITEBOOK", ADD the following:

1. Unless specified otherwise, the Contract Price includes use, consumer, and other taxes mandated by applicable legal requirements.
2. As provided in §7105 of the California Public Contract Code, if the Contract is not financed by revenue bonds, you are not responsible for the cost of repairing or restoring damage to the Project when damage was proximately caused by an act of God, in excess of 5% of the Contract Price, if the following occur:
 - a) The Project damaged was built in accordance with the Contract requirements.
 - b) There are no insurance requirements in the Contract for the damages.
3. The Lump Sum Bid item for "**Wangenheim Neighborhood Park Joint Use Facility**" shall include, and not be limited to, demolition, grading, new grass fields, ball field, storm drain, water quality detention basin, snack bar/comfort station, sewer and water lateral and irrigation systems, shade sails to cover existing playground, retaining walls, parking lot, curb ramps, sidewalks, DG trail, sport lighting, fencing, backstops, and landscaping as specified in the Plans, Contract Documents, and Technicals Section.

7-3.2 Partial and Final Payment. To the "GREENBOOK", paragraph (3), DELETE in its entirety and SUBSTITUTE with the following:

Upon commencement of the Work, an escrow account shall be established in a financial institution chosen by you and approved by the City. Documentation for an escrow payment shall have an escrow agreement signed by you, the City, and the escrow agent. From each progress payment, no less than 5% will be deducted and deposited by the City into the escrow account. Upon completion of the Contract, the

City will notify the Escrow agent in writing to release the funds to you. Only the designated representative of the City shall sign the request for the release of Escrow funds.

To the "WHITEBOOK", item 1, DELETE in its entirety and SUBSTITUTE with the following:

1. The Final Payment, which is the release of Retention, shall be paid to you after you have successfully submitted the following required documents:
 - a) An affidavit that payrolls and bills for materials, equipment, and other indebtedness connected with the Work for which the City or the City's property might be responsible for or encumbered by.
 - b) A certificate evidencing that insurances required by the Contract Documents shall remain in force after Final Payment is currently in effect and shall not be canceled or allowed to expire until at least a 30 Calendar Days prior written notice has been given to the Engineer.
 - c) Consent of Surety to Final Payment.
 - d) If required by the Engineer, other data establishing payment or satisfaction of obligations such as receipts, releases and waivers of liens, claims, and security interests or encumbrances arising out of the Contract Documents. If a Subcontractor refuses to furnish a release or waiver required by the City, you may furnish a bond satisfactory to the Engineer to indemnify the City against such lien.
 - e) If required in the Contract Documents, the successful completion and submittal of the required reports such as construction demolition, waste recycling, and hydrostatic discharge reports.
 - f) Required EOCP Final Summary Report in accordance with Section 0-12, "Contract Records and Reports", record drawings, operations manuals, test reports, warranty documentation, and UL labels shall be submitted before requesting the release of retention.
 - g) Acceptance of the completed Project by the asset owning Department.

To the "WHITEBOOK", ADD the following:

2. Submit an invoice for payment after you successfully complete the required documents and the City will pay the invoice within 30 Calendar Days. The City will pay 6% annually for late retention payments.

7-3.2.1 Application for Progress Payment. To the "WHITEBOOK", item 3, DELETE in its entirety and SUBSTITUTE with the following:

3. The City shall not pay progress or partial payments until you submit to the Engineer an acceptable updated Schedule. It is solely your responsibility to prepare and submit the Schedule updates.

7-3.2.2 Amount of Progress Payments. To the "WHITEBOOK", DELETE in its entirety and SUBSTITUTE with the following:

1. The City will pay 6% annually for late progress payments.

2. Progress payments will be considered “late” if the following occur:
 - a) The City does not pay the contractor within 30 Calendar Days from receipt of an undisputed and properly submitted invoice. A properly submitted payment invoice means that the City has approved for payment the entire invoice amount or if the Resident Engineer has not disputed any portion of the application within 7 Calendar Days of the date of submission.
 - b) The application for payment does not require signing of a Contract Change Order.
3. The Engineer may withhold payment for any of the following reasons:
 - a) Defective or incomplete Work.
 - b) Not providing an updated and accurate Cost Loaded Construction Schedule in accordance with 6-1.1, “Construction Schedule”.
 - c) Stop notices, wage orders, or other withholdings required by Applicable Law. Your failure to comply with 5-3.3, “Payroll Records” and the Contractor Registration and Electronic Reporting System requirements of the Contract Documents.
4. The Engineer may back charge the contract for any of the following reasons:
 - a) Defective or incorrect Work not remedied.
 - b) Damage to City property or a third party’s property that was caused by you.
 - c) Liquidated Damages.

7-3.2.3 Waiver of Claims at Final Payment. To the “WHITEBOOK”, DELETE in its entirety and SUBSTITUTE with the following:

1. Your acceptance of Final Payment constitutes a waiver of affirmative Claims by you, except those previously made in writing and identified as unsettled at the time of Final Payment.

7-3.2.4 Withholding of Payment and Back Charge. To the “WHITEBOOK”, DELETE in its entirety.

7-3.5.1 General. To the “WHITEBOOK”, DELETE in its entirety and SUBSTITUTE with the following:

1. Unit Bid prices shall not be subject to adjustment regardless of quantity used, or if none is used, for the following Bid items:
 - a) imported backfill
 - b) shoring
 - c) water services
 - d) house connection sewers
 - e) water pollution control items

2. Upon discovery and prior to the Work, you shall notify the Resident Engineer if there is a change in Bid item quantity that increases the total Contract Price by 5% or \$100,000 or more, whichever is less.

7-3.9

Field Orders. To the "WHITEBOOK", DELETE in its entirety and SUBSTITUTE with the following:

1. If the cumulative total of Field Order items of Work does not exceed the "Field Orders" Bid Item, the City shall pay those Field Orders as shown below:

TABLE 7-3.9

FIELD ORDER LIMITS

Contract Price	Maximum Field Order Work Amount
Less than \$100,001	\$2,500
\$100,001 to \$1,000,000	\$5,000
\$1,000,001 to \$5,000,000	\$10,000
\$5,000,001 to \$15,000,000	\$20,000
\$15,000,001 to \$30,000,000	\$40,000
Greater than \$30,000,000	\$50,000

2. Field Order items of Work for contracts greater than \$15,000,000 will require additional approvals from the City prior to its approval by the Resident Engineer.
3. The City will issue a Field Order only after the City's acceptance of the cost of the field order amount.
4. Field Orders shall not be used to add scope or to include extensions of time related to changes in work.
5. If in the event there is a change related to the critical path on the project which necessitates an extension of time and the change amount is within the Field Order limits shown on Table 7-3.9, then a Field Order can be issued to compensate you for the approved costs. Any extensions of time associated with the change shall be included in a subsequent Change Order and no additional compensation shall be granted as part of the change order for the extension of time.
6. The unused portions of Field Orders Bid item shall revert to the City upon Acceptance.

SECTION 203 – BITUMINOUS MATERIALS

203-6.3.1 General. To the “WHITEBOOK”, ADD the following:

3. Asphalt concrete for Job Mix Formula (JMF) and Mix Designs shall be Type III and shall not exceed 15% RAP.

SECTION 300 – EARTHWORK

300-1.1 General. ADD the following:

Prior to submittal of a Bid for this Work, the Contractor shall inspect the project site to verify the magnitude and cost of all clearing and grubbing required to accomplish the Work.

SECTION 301 – SUBGRADE PREPARATION, TREATED MATERIALS, AND PLACEMENT OF BASE MATERIALS

301-1.2 Preparation of Subgrade. ADD the following:

Contractor shall harvest and stockpile all on-site D.G. for later use in field grading and construction.

301-1.6 Preparatory Repair Work. To the “WHITEBOOK”, item 1, DELETE in its entirety and SUBSTITUTE with the following:

1. Prior to the placement of any asphalt concrete or application of slurry, you shall complete all necessary preparation and repair Work and shall obtain approval by the Resident Engineer.

ADD the following:

13. Asphalt concrete shall be Type III and shall not exceed 15% RAP in accordance with 203-6.3.1, “General”.

SECTION 303 – CONCRETE AND MASONRY CONSTRUCTION

303-1.1 General. ADD the following:

The Contractor shall construct storm drain catch basins for drainage purposes as shown on the plans. No steps will be required for these new storm drain structures. Storm drain catch basins shall conform to the provisions of Section 201-1, 201-2 and 303-1 of the Greenbook, Whitebook, Special Provisions, and Standard Drawings.

In case of conflict between the concrete strength (560-C-3250) shown in Section 201-1.1.2 of the Greenbook, the higher strength shown shall govern.

All reinforcing steel shall be Grade 60, ASTM Designation: A615.

303-5.1.1 General. To the “WHITEBOOK”, ADD the following:

7. For the purposes of this section, the terms “walk” and “access ramp” shall be synonymous with “sidewalk” and “curb ramp and pedestrian ramp”, respectively.

303-5.10.2 Payment. To the "WHITEBOOK", ADD the following:

4. The payment for completely removing and replacing the existing concrete spandrel of a cross gutter associated with curb ramp installations, in accordance with SDG-131 - General Curb Ramp Notes, and as identified on the Plans, shall be included in the payment for the curb ramp. No additional costs shall be incurred when separate Bid items for cross gutters has been provided.
5. The payment for completely removing and replacing the existing concrete alley apron associated with curb ramp installations, in accordance with SDG-131 - General Curb Ramp Notes, and as identified on the Plans, shall be included in the payment for the Curb Ramp installation. No additional costs shall be incurred when separate Bid items for alley aprons has been provided.

SECTION 306 – OPEN TRENCH CONDUIT CONSTRUCTION

306-8.9.2.3 Allowable Leakage. To the "GREENBOOK", DELETE in its entirety and SUBSTITUTE with the following:

1. For prefabricated pressure pipe testing requirements, refer to prefabricated gravity pipe pressure testing requirements in 306-7.8.2, "Pressure Testing and Leakage Inspection".

SECTION 314 – TRAFFIC STRIPING, CURB AND PAVEMENT MARKINGS, AND PAVEMENT MARKERS

314-4.4.5 Measurement. To the "WHITEBOOK", item 1, DELETE in its entirety and SUBSTITUTE with the following:

2. Thermoplastic traffic striping for continental crosswalks shall be measured by the square foot for the actual area covered with thermoplastic.

SECTION 402 – UTILITIES

402-2 PROTECTION. To the "WHITEBOOK", item 2, ADD the following:

- g) Refer to **Appendix H - Advanced Metering Infrastructure (AMI) Device Protection** for more information on the protection of AMI devices.

402-6 COOPERATION. To the "GREENBOOK", ADD the following:

1. Notify SDG&E at least 10 Working Days prior to excavating within 10 feet of SDG&E Underground High Voltage Transmission Power Lines (69 KV and higher).

402-7.2 Pipe Separations. To the "WHITEBOOK", item 1, subsection "a", DELETE in its entirety and SUBSTITUTE with the following:

- a) You shall notify the Engineer immediately if:
 - i. 1 foot (0.3 m) vertical separation as measured from the outside of pipe wall to the outside of pipe wall between sewer and water mains cannot be maintained.

- ii. 10 feet (3.0 m) horizontal separation as measured from the outside of pipe wall to the outside of pipe wall between sewer and water mains cannot be maintained.
- iii. 6 inches (152.4 mm) vertical separation as measured from the outside of pipe wall to the outside of pipe wall between utilities other than sewer and water mains cannot be maintained.
- iv. 3 feet (0.9 m) or more of cover over the top of the water main cannot be maintained.
- v. 5 feet (1.5 m) or more of cover over the top of the recycled water main cannot be maintained.

**SECTION 601 - TEMPORARY TRAFFIC CONTROL FOR CONSTRUCTION
AND MAINTENANCE WORK ZONES**

601-2.1.4 Traffic Control for Resurfacing and Slurry Sealing. To the "WHITEBOOK", item 3, subsection "d", DELETE in its entirety and SUBSTITUTE with the following:

- d) Place "NO PARKING - TOW-AWAY ZONE" signs 72 hours in advance of the scheduled slurry sealing. Reschedule street block segments which are not completed by the last posted Working Day. If a Work delay of 48 hours or more occurs from the originally scheduled Work date, remove the "NO PARKING - TOW-AWAY ZONE" signs for a minimum of 24 hours, then reset and re-post for the appropriate Work date.

601-3.5.1 General. To the "WHITEBOOK", item 3, DELETE in its entirety and SUBSTITUTE with the following:

- 3. Temporary "No Parking" and "No Stopping" signs shall be installed 72 hours before enforcement. Temporary "No Parking" and "No Stopping" signs shall be installed and removed as specified in the Special Provisions. Signs shall indicate specific days, dates, and times of restrictions. If violations occur, call Police Dispatch 619-531-2000 to enforce the Tow-Away notice.

601-3.6 Channelizing Devices. To the "WHITEBOOK", item 4, Barricades, ADD the following:

- h) You shall place "OPEN TRENCH" signs (C27(CA)) on Type 3 Barricade within the construction Work zone, ahead of any Work areas with open trenches that are greater than 3 inches in depth, in accordance with California MUTCD SECTION 6F.103 (CA). The barricades shall be placed in a continuous manner and shall prevent pedestrian, vehicular, and biker access to the open trench area.

601-7 PAYMENT. To the "WHITEBOOK", item 1, DELETE in its entirety and SUBSTITUTE with the following:

- 1. The Bid item for "Traffic Control and Working Drawings" shall include payment for:
 - a) Providing all required traffic permits in accordance with 601-2.1.1, "Traffic Control Permit" including payment for fees and all associated work to obtain the approved permit.
 - b) Providing approved Traffic Control Working Drawings in accordance with 601-2.1, "Traffic Control Plan (TCP)" and its subsections.

- c) Providing and implementing traffic control Work and any traffic control devices that may be required by the City associated to the approved permit and Traffic Control Working Drawings.

SECTION 800 – MATERIALS

800-1.2.4 Organic Soil Amendment. To the “WHITEBOOK”, ADD the following:

Organic soil amendment shall Type 4 organic soil amendment.

800-1.2.5 Mulch. To the “WHITEBOOK”, ADD the following:

Mulch at landscape beds shall be a premium type 9 mulch (recycled): a 3-inch minus.

Mulch at water quality basin mulch shall be Gorilla Hair 4” thick layer.

800-2.2.17 Booster Pumps. To the “WHITEBOOK”, DELETE in its entirety and SUBSTITUTE with the following:

- 1.1 The water pressure booster pump shall be designed and fabricated by Barrett Engineered Pumps or approved equal. The system shall be a completely prefabricated system with pump, piping, electrical and structural elements. The entire booster pump assembly shall be UL Listed and Approved.
- 1.2 Pump shall be:
 - 1.2.1 (PACO Series) Single stage end suction close coupled centrifugal, cast iron bronze fitted construction, equipped with mechanical shaft seal, back pullout design. Impeller shall be threaded directly to the end of the shaft. Pump shaft shall be stainless steel with no sleeve. Pump shall be directly coupled to a C-face electric motor.
- 1.3 Electric motor shall be of the squirrel cage induction type suitable for full voltage starting. Motor shall be ODP to aid in cooling. Electric motor shall be rated for continuous service. The motor shall have horsepower ratings such that the motor will carry the maximum possible load to be developed under the designed pumping conditions and not overload the motor beyond the nameplate rating of the motor. Motor shall have a 1.15 service factor. The motor shall conform to the latest NEMA Standards for motor design and construction.
- 1.4 Pump Control Panel shall have a NEMA3R plain front non-metallic enclosure with padlock latches. This Includes power and control re-settable thermal circuit breakers, heavy duty magnetic starter with adjustable overload protection, Hand-Off-Auto switch to select mode of operation, and heavy duty numbered terminal strips for power and control wiring lead terminations.
- 1.5 If 24V control started, a Metal oxide varistor protected pump start relay shall be incorporated in panel to start pump with signal from an irrigation controller.

- 1.6 All system piping shall be Schedule 10S 304 stainless steel. All major fittings shall be 304 stainless steel with flanges to allow for system disassembly or major component removal. All instrumentation fittings shall be 304SS. System shall incorporate an integral full pipe size bypass line with isolation valve to allow for pump removal and repair without disrupting water supply to system.
- 1.7 Isolation valves shall be all stainless quarter turn ball valves with hard chrome ball on lines 2" and less. Isolation valves shall be lug style butterfly valves with Buna-N elastomeric seats, ductile iron nickel coated disc, and stainless steel stem with handle and 10 position galvanized memory plate on lines 2½" and greater.
- 1.8 Gauges shall be 2½" diameter face, glycerin filled with stainless casing and brass internals.
- 1.9 Flow switch shall be a 316 stainless steel and solid state thermal sensor designed to measure change in flow velocity and in temperature. The flow switch shall include an integrated bar graph with 10 LED lights and shall be capable of providing indication of flow (green), closed (orange), and open (red) conditions.
- 1.10 Pump system shall be mounted on a structural aluminum skid with mounting flanges on front and back to allow for mounting of skid to concrete pad. Skid equipped with pipe support on suction and discharge piping. All nuts and bolts and washers shall be stainless steel on skid and piping. Skid shall include mounting hardware for integral aluminum enclosure.
- 1.11 The system enclosure shall be vandal and weather resistant, marine grade aluminum alloy 5052-H32 construction with rectangular punch-outs for viewing and heat dissipation. The enclosure shall be low profile hinged top design with padlock provision. The cover shall be secured to the concrete pad with stainless steel hardware. The enclosure shall measure 42D" x 60W" x 48H" and concrete pad dimensions shall be 54" x 72" x 4". The enclosure shall be as manufactured by V.I.T. Products, Inc.
- 1.12 Pump Assembly shall include the following option(s):
- ✓ **(VFD-F)** Where specified by the System Design Parameters, a **Fuji Variable Frequency Drive** system to receive feedback signal from system mounted stainless steel pressure transducer, and in conjunction with internal software driven PID control loop maintain customer adjustable constant system discharge pressure by varying the speed of the pump in response to varying system load.
 - ✓ **(IP-60)** Where specified in the System Design Parameters, all inlet and discharge connections shall be plumbed to provide access through the base of the provided marine grade enclosure. All electrical conduits shall also be accessible from the bottom of the control panel cabinet.
- 1.13 The services of a factory representative or trained service professional shall be made available on the job site to check installation and perform the startup and instruct the operating personnel. A startup report containing

voltage and amperage readings, suction and discharge pressure readings, estimated flow conditions, and general operating characteristics shall be submitted to the Owner.

- 1.14 One electronic set of operating and maintenance manual shall be provided to the owner after startup and shall include parts manuals for major components, performance curve for pump, general sequence of operation, and electrical schematic for control panel.
- 1.15 The warranty period shall be a non-prorated period of 36 months from date of purchase.

SECTION 801 - INSTALLATION

801-2.2.1 General To the "WHITEBOOK", Add the following:

- 1.0 Topsoil in Turf Areas

In areas to be planted in turf, the existing site soil shall be excavated to a depth of 15" below finish grade. The subgrade soil shall be scarified in a cross pattern to a depth of 3" (75 mm) and rocks over 1" (25 mm) in greatest dimension shall be removed from the scarified area. The excavated site soil shall be screened to remove all rocks and debris ½" and greater in size, and screened site soil shall be placed to a depth of not more than 5" (125 mm). Class A topsoil shall then be placed to a depth of not less than 10" (300 mm) to finish grade.

SECTION 1001 - CONSTRUCTION BEST MANAGEMENT PRACTICES (BMPs)

1001-1 GENERAL. To the "WHITEBOOK", ADD the following:

- 7. Based on a preliminary assessment by the City, this Contract is subject to **SWPPP**.

1001-2.10 BMP Inspection, Maintenance, and Repair. To the "WHITEBOOK", ADD the following:

- 5. Maintenance activities shall be documented by the QSP or QSD in the Construction BMP Maintenance Log for projects subject to SWPPP requirements. See **Appendix J - SWPPP Construction BMP Maintenance Log**.

1001-3.7 Payment. To the "WHITEBOOK", item 3, subsection "g", DELETE in its entirety and SUBSTITUTE with the following:

- g) BMP Inspection, Maintenance, Repair, and Construction BMP Maintenance Log.

TECHNICALS

PROJECT MANUAL
FOR
CITY OF SAN DIEGO
WANGENHEIM NEIGHBORHOOD JOINT USE FACILITY
SAN DIEGO, CALIFORNIA

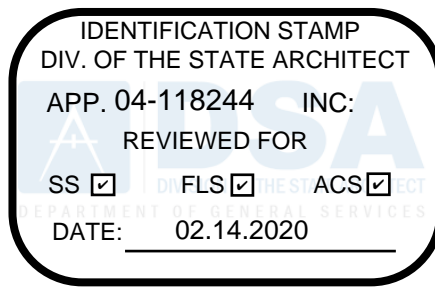

12/20/2019

FOR CONSTRUCTION

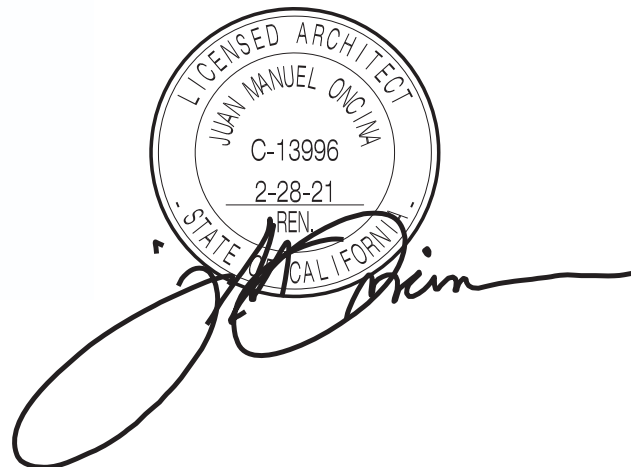

TABLE OF CONTENTS

ARCHITECTURAL SPECIFICATIONS

033000	CAST-IN-PLACE CONCRETE.....	4
042200	CONCRETE UNIT MASONRY	21
051200	STRUCTURAL STEEL FRAMING.....	35
051213	ARCHITECTURALLY EXPOSED STRUCTURAL STEEL FRAMING.....	44
055000	METAL FABRICATIONS.....	50
055313	BAR GRATINGS.....	60
061000	ROUGH CARPENTRY.....	65
061600	SHEATHING.....	74
061800	GLUED-LAMINATED CONSTRUCTION.....	77
074113.16	STANDING-SEAM METAL ROOF PANELS.....	82
074646	FIBER-CEMENT SOFFIT.....	93
076200	SHEET METAL FLASHING AND TRIM.....	97
079200	JOINT SEALANTS	108
081113	HOLLOW METAL DOORS AND FRAMES.....	117
083313	COILING COUNTER DOORS.....	122
087100	DOOR HARDWARE.....	128
099600	HIGH-PERFORMANCE COATINGS.....	150
101423.13	ROOM-IDENTIFICATION SIGNAGE.....	157
102800	TOILET, BATH, AND LAUNDRY ACCESSORIES.....	163
104416	FIRE EXTINGUISHERS.....	168

PLUMBING SPECIFICATIONS

22 00 00	GENERAL PLUMBING REQUIREMENTS.....	171
22 05 13	COMMON MOTOR REQUIREMENTS FOR PLUMBING EQUIPMENT.....	181
22 05 17	SLEEVES AND SLEEVE SEALS FOR PLUMBING PIPING.....	184
22 05 18	ESCUTCHEONS FOR PLUMBING PIPING.....	189
22 05 19	METERS AND GAGES FOR PLUMBING PIPING.....	192
22 05 23	GENERAL-DUTY VALVES FOR PLUMBING PIPING.....	201
22 05 29	HANGERS AND SUPPORTS FOR PLUMBING PIPING AND EQUIPMENT	215

22 05 48	VIBRATION AND SEISMIC CONTROLS FOR PLUMBING PIPING AND EQUIPMENT	228
22 05 53	IDENTIFICATION FOR PLUMBING PIPING AND EQUIPMENT	235
22 07 19	PLUMBING PIPING INSULATION	240
22 11 16	DOMESTIC WATER PIPING	262
22 11 19	DOMESTIC WATER PIPING SPECIALTIES	275
22 13 16	SANITARY WASTE AND VENT PIPING	288
22 13 19	SANITARY WASTE AND VENT PIPING SPECIALTIES	302
22 14 13	FACILITY STORM DRAINAGE PIPING	313
22 14 23	STORM DRAINAGE PIPING SPECIALTIES	326
22 33 00	ELECTRIC, DOMESTIC-WATER HEATERS	333
22 46 00	SECURITY PLUMBING FIXTURES	340

MECHANICAL SPECIFICATIONS

23 00 00	GENERAL MECHANICAL REQUIREMENTS	346
23 05 00	BASIC MECHANICAL MATERIALS AND METHODS	357
23 05 29	HANGERS AND SUPPORTS FOR HVAC PIPING AND EQUIPMENT	362
23 05 53	IDENTIFICATION FOR HVAC PIPING AND EQUIPMENT	365
23 05 93	TESTING, ADJUSTING, AND BALANCING	367
23 31 13	METAL DUCTS	374
23 33 00	AIR DUCT ACCESSORIES	378
23 34 23	HVAC POWER VENTILATORS	381
23 37 13	DIFFUSERS, REGISTERS, AND GRILLES	384

ELECTRICAL SPECIFICATIONS

26 05 00	GENERAL ELECTRICAL REQUIREMENTS	386
26 05 19	LOW-VOLTAGE ELECTRICAL POWER CONDUCTORS AND CABLES	395
26 05 26	GROUNDING AND BONDING FOR ELECTRICAL SYSTEMS	399
26 05 29	HANGERS AND SUPPORTS FOR ELECTRICAL SYSTEMS	404
26 05 33	RACEWAYS AND BOXES FOR ELECTRICAL SYSTEMS	409
26 05 44	SLEEVES & SLEEVE SEALS FOR ELECTRICAL RACEWAYS AND CABLING	416
26 05 48	VIBRATION AND SEISMIC CONTROLS FOR ELECTRICAL SYSTEMS	420

26 05 53	IDENTIFICATION FOR ELECTRICAL SYSTEMS.....	426
26 22 00	LOW-VOLTAGE TRANSFORMERS.....	433
26 24 13	SWITCHBOARDS.....	437
26 24 16	PANELBOARDS.....	442
26 27 26	WIRING DEVICES.....	448
26 28 13	FUSES.....	453
26 28 16	ENCLOSED SWITCHES AND CIRCUIT BREAKERS.....	455
26 51 00	INTERIOR LIGHTING.....	460
26 55 68	EXTERIOR ATHLETIC LIGHTING.....	464
26 56 00	EXTERIOR LIGHTING.....	470

LANDSCAPE AND IRRIGATION SPECIFICATIONS

087100	EXIT HARDWARE.....	474
129313	BICYCLE RACKS.....	477
130125	BLEACHER.....	480
133123	PRE-ENGINEERED FABRIC SHADE STRUCTURES.....	483
321540	DG SURFACING.....	490
321823	INFIELD SURFACING.....	492
323343	BENCHES.....	495

SECTION 033000 - CAST-IN-PLACE CONCRETE

PART 1 - GENERAL

1.1 RELATED DOCUMENTS

- A. Drawings and general provisions of the Contract - Standard Specifications for Public Works Construction 'The GREENBOOK' and City Supplement 'The WHITEBOOK', latest editions, including Supplemental Supplementary Provisions (SSPs), apply to this Section.

1.2 SUMMARY

- A. Section includes cast-in-place concrete, including formwork, reinforcement, concrete materials, mixture design, placement procedures, and finishes.
- B. Related Requirements:
 - 1. Section 300 "Earthwork" for drainage fill under slabs-on-grade.

1.3 DEFINITIONS

- A. Cementitious Materials: Portland cement alone or in combination with one or more of the following: blended hydraulic cement, fly ash, slag cement, other pozzolans, and silica fume; materials subject to compliance with requirements.
- B. W/C Ratio: The ratio by weight of water to cementitious materials.

1.4 PREINSTALLATION MEETINGS

- A. Preinstallation Conference: Conduct conference at Project site.
 - 1. Before submitting design mixtures, review concrete design mixture and examine procedures for ensuring quality of concrete materials. Require representatives of each entity directly concerned with cast-in-place concrete to attend, including the following:
 - a. Contractor's superintendent.
 - b. Independent testing agency responsible for concrete design mixtures.
 - c. Ready-mix concrete manufacturer.
 - d. Concrete Subcontractor.
 - 2. Review special inspection and testing and inspecting agency procedures for field quality control, concrete finishes and finishing, cold- and hot-weather concreting procedures, curing procedures, construction contraction and isolation joints, and joint-filler strips, semirigid joint fillers, forms and form removal limitations, shoring and reshoring procedures, vapor-retarder installation, anchor rod and anchorage device installation tolerances, steel reinforcement installation, methods for achieving specified floor and slab flatness and levelness, floor and slab flatness and levelness measurement, concrete repair procedures, and concrete protection.

1.5 ACTION SUBMITTALS

- A. Product Data: For each type of product.
- B. Design Mixtures: For each concrete mixture. Submit alternate design mixtures when characteristics of materials, Project conditions, weather, test results, or other circumstances warrant adjustments.
 - 1. Indicate amounts of mixing water to be withheld for later addition at Project site.
- C. Steel Reinforcement Shop Drawings: Placing Drawings that detail fabrication, bending, and placement. Include bar sizes, lengths, material, grade, bar schedules, stirrup spacing, bent bar diagrams, bar arrangement, splices and laps, mechanical connections, tie spacing, hoop spacing, and supports for concrete reinforcement.
- D. Construction Joint Layout: Indicate proposed construction joints required to construct the structure.
 - 1. Location of construction joints is subject to approval of the Architect.
- E. Samples: For vapor retarder.

1.6 INFORMATIONAL SUBMITTALS

- A. Qualification Data: For Installer, manufacturer, testing agency.
- B. Welding certificates.
- C. Material Certificates: For each of the following, signed by manufacturers:
 - 1. Cementitious materials.
 - 2. Admixtures.
 - 3. Form materials and form-release agents.
 - 4. Steel reinforcement and accessories.
 - 5. Curing compounds.
 - 6. Floor and slab treatments.
 - 7. Bonding agents.
 - 8. Adhesives.
 - 9. Vapor retarders.
 - 10. Semirigid joint filler.
 - 11. Joint-filler strips.
 - 12. Repair materials.
- D. Material Test Reports: For the following, from a qualified testing agency:
 - 1. Aggregates: Include service record data indicating absence of deleterious expansion of concrete due to alkali aggregate reactivity.
- E. Field quality-control reports.
- F. Minutes of preinstallation conference.

1.7 QUALITY ASSURANCE

- A. Installer Qualifications: A qualified installer who employs on Project personnel qualified as ACI-certified Flatwork Technician and Finisher and a supervisor who is an ACI-certified Concrete Flatwork Technician.
- B. Manufacturer Qualifications: A firm experienced in manufacturing ready-mixed concrete products and that complies with ASTM C 94/C 94M requirements for production facilities and equipment.
 - 1. Manufacturer certified according to NRMCA's "Certification of Ready Mixed Concrete Production Facilities."
- C. Testing Agency Qualifications: An independent agency, acceptable to authorities having jurisdiction, qualified according to ASTM C 1077 and ASTM E 329 for testing indicated.
 - 1. Personnel conducting field tests shall be qualified as ACI Concrete Field Testing Technician, Grade 1, according to ACI CP-1 or an equivalent certification program.
 - 2. Personnel performing laboratory tests shall be ACI-certified Concrete Strength Testing Technician and Concrete Laboratory Testing Technician, Grade I. Testing agency laboratory supervisor shall be an ACI-certified Concrete Laboratory Testing Technician, Grade II.
- D. Welding Qualifications: Qualify procedures and personnel according to AWS D1.4/D 1.4M.

1.8 PRECONSTRUCTION TESTING

- A. Preconstruction Testing Service: Engage a qualified testing agency to perform preconstruction testing on concrete mixtures.

1.9 DELIVERY, STORAGE, AND HANDLING

- A. Steel Reinforcement: Deliver, store, and handle steel reinforcement to prevent bending and damage.

1.10 FIELD CONDITIONS

- A. Cold-Weather Placement: Comply with ACI 306.1 and as follows. Protect concrete work from physical damage or reduced strength that could be caused by frost, freezing actions, or low temperatures.
 - 1. When average high and low temperature is expected to fall below 40 deg F (4.4 deg C) for three successive days, maintain delivered concrete mixture temperature within the temperature range required by ACI 301 (ACI 301M).
 - 2. Do not use frozen materials or materials containing ice or snow. Do not place concrete on frozen subgrade or on subgrade containing frozen materials.
 - 3. Do not use calcium chloride, salt, or other materials containing antifreeze agents or chemical accelerators unless otherwise specified and approved in mixture designs.
- B. Hot-Weather Placement: Comply with ACI 301 (ACI 301M) and ACI 305.1 (ACI 305.1M), and as follows:

1. Maintain concrete temperature below 90 deg F (32 deg C) at time of placement. Chilled mixing water or chopped ice may be used to control temperature, provided water equivalent of ice is calculated to total amount of mixing water. Using liquid nitrogen to cool concrete is Contractor's option.
2. Fog-spray forms, steel reinforcement, and subgrade just before placing concrete. Keep subgrade uniformly moist without standing water, soft spots, or dry areas.

1.11 REGULATORY REQUIREMENTS

- A. Portland Cement Concrete paving and concrete finishes:
 1. Portland cement concrete paving shall be stable, firm and slip resistant and shall comply with CBC Sections 11B-302 and 11B-403.

PART 2 - PRODUCTS

2.1 CONCRETE, GENERAL

- A. ACI Publications: Comply with the following unless modified by requirements in the Contract Documents:
 1. ACI 301 (ACI 301M).
 2. ACI 117 (ACI 117M).

2.2 FORM-FACING MATERIALS

- A. Smooth-Formed Finished Concrete: Form-facing panels that provide continuous, true, and smooth concrete surfaces. Furnish in largest practicable sizes to minimize number of joints.
 1. Exterior-grade plywood panels, suitable for concrete forms, complying with DOC PS 1, and as follows:
 - a. B-B (Concrete Form), Class 1 or better; mill oiled and edge sealed.
- B. Rough-Formed Finished Concrete: Plywood, lumber, metal, or another approved material. Provide lumber dressed on at least two edges and one side for tight fit.
- C. Void Forms: Biodegradable paper surface, treated for moisture resistance, structurally sufficient to support weight of plastic concrete and other superimposed loads.
- D. Chamfer Strips: Wood, metal, PVC, or rubber strips, 3/4 by 3/4 inch (19 by 19 mm), minimum.
- E. Rustication Strips: Wood, metal, PVC, or rubber strips, kerfed for ease of form removal.
- F. Form-Release Agent: Commercially formulated form-release agent that does not bond with, stain, or adversely affect concrete surfaces and does not impair subsequent treatments of concrete surfaces.
 1. Formulate form-release agent with rust inhibitor for steel form-facing materials.

- G. Form Ties: Factory-fabricated, removable or snap-off glass-fiber-reinforced plastic or metal form ties designed to resist lateral pressure of fresh concrete on forms and to prevent spalling of concrete on removal.
 - 1. Furnish units that leave no corrodible metal closer than **1 inch (25 mm)** to the plane of exposed concrete surface.
 - 2. Furnish ties that, when removed, leave holes no larger than **1 inch (25 mm)** in diameter in concrete surface.

2.3 STEEL REINFORCEMENT

- A. Reinforcing Bars: ASTM A 615/A 615M, **Grade 60 (Grade 420)**, deformed.
- B. Low-Alloy-Steel Reinforcing Bars: ASTM A 706/A 706M, deformed.

2.4 REINFORCEMENT ACCESSORIES

- A. Joint Dowel Bars: ASTM A 615/A 615M, **Grade 60 (Grade 420)**, plain-steel bars, cut true to length with ends square and free of burrs.
- B. Zinc Repair Material: ASTM A 780/A 780M.
- C. Bar Supports: Bolsters, chairs, spacers, and other devices for spacing, supporting, and fastening reinforcing bars and welded-wire reinforcement in place. Manufacture bar supports from steel wire, plastic, or precast concrete according to CRSI's "Manual of Standard Practice," of greater compressive strength than concrete and as follows:
 - 1. For concrete surfaces exposed to view, where legs of wire bar supports contact forms, use CRSI Class 2 stainless-steel bar supports.

2.5 CONCRETE MATERIALS

- A. Source Limitations: Obtain each type or class of cementitious material of the same brand from the same manufacturer's plant, obtain aggregate from single source, and obtain admixtures from single source from single manufacturer.
- B. Cementitious Materials:
 - 1. Portland Cement: ASTM C 150/C 150M, Type V, gray.
- C. Normal-Weight Aggregates: ASTM C 33/C 33M. Class 1N coarse aggregate or better, graded. Provide aggregates from a single source .
 - 1. Maximum Coarse-Aggregate Size:
 - a. **1 inch (25 mm)** at FOUNDATION and MASS CONCRETE WORK.
 - b. **3/4 inch (19 mm)** at SLAB, WALLS, and other CONCRETE WORK.
 - 2. Fine Aggregate: Free of materials with deleterious reactivity to alkali in cement.
- D. Air-Entraining Admixture: ASTM C 260/C 260M.

- E. Chemical Admixtures: Certified by manufacturer to be compatible with other admixtures and that do not contribute water-soluble chloride ions exceeding those permitted in hardened concrete. Do not use calcium chloride or admixtures containing calcium chloride.

ADMIXTURES shall NOT be used unless substantiating data is submitted to, and accepted by the Engineer (EOR) and Architect of Record (AOR.)

- 1. Water-Reducing Admixture: ASTM C 494/C 494M, Type A.
- 2. Retarding Admixture: ASTM C 494/C 494M, Type B.
- 3. Water-Reducing and Retarding Admixture: ASTM C 494/C 494M, Type D.
- 4. High-Range, Water-Reducing Admixture: ASTM C 494/C 494M, Type F.
- 5. High-Range, Water-Reducing and Retarding Admixture: ASTM C 494/C 494M, Type G.
- 6. Plasticizing and Retarding Admixture: ASTM C 1017/C 1017M, Type II.

- F. Water: ASTM C 94/C 94M and potable.

2.6 VAPOR RETARDERS

- A. Sheet Vapor Retarder: ASTM E 1745, Class A. Include manufacturer's recommended adhesive or pressure-sensitive tape.

- 1. Manufacturers: Subject to compliance with requirements, provide products by one of the following:
 - a. Reef Industries, Inc.
 - b. Stego Industries, LLC.
 - c. W. R. Meadows, Inc.
- 2. Minimum Thickness: 15 mils.

2.7 LIQUID FLOOR TREATMENTS

- A. Penetrating Liquid Floor Treatment: Clear, chemically reactive, waterborne solution of inorganic silicate or silicate materials and proprietary components; odorless; that penetrates, hardens, and densifies concrete surfaces.

- 1. Manufacturers: Subject to compliance with requirements, provide products by one of the following:
 - a. BASF Corp. - Construction Chemicals.
 - b. Dayton Superior.
 - c. Euclid Chemical Company (The); an RPM company.
 - d. PROSOCO, Inc.
 - e. W.R. Meadows, Inc.

2.8 CURING MATERIALS

- A. Absorptive Cover: AASHTO M 182, Class 2, burlap cloth made from jute or kenaf, weighing approximately **9 oz./sq. yd. (305 g/sq. m)** when dry.

- B. Moisture-Retaining Cover: ASTM C 171, polyethylene film or white burlap-polyethylene sheet.
- C. Water: Potable.

2.9 RELATED MATERIALS

- A. Expansion- and Isolation-Joint-Filler Strips: **ASTM D 1751, asphalt-saturated cellulosic fiber or ASTM D 1752, cork or self-expanding cork.**
- B. Semirigid Joint Filler: Two-component, semirigid, 100 percent solids, **epoxy resin with a Type A shore durometer hardness of 80** according to ASTM D 2240.
- C. Bonding Agent: ASTM C 1059/C 1059M, Type II, nonredispersible, acrylic emulsion or styrene butadiene.
- D. Epoxy Bonding Adhesive: ASTM C 881, two-component epoxy resin, capable of humid curing and bonding to damp surfaces, of class suitable for application temperature and of grade to suit requirements, and as follows:
 - 1. Types IV and V, load bearing, for bonding hardened or freshly mixed concrete to hardened concrete.

2.10 REPAIR MATERIALS

- A. Repair Overlayment: Cement-based, polymer-modified, self-leveling product that can be applied in thicknesses from **1/4 inch (6.4 mm)** and that can be filled in over a scarified surface to match adjacent floor elevations.
 - 1. Cement Binder: ASTM C 150/C 150M, portland cement or hydraulic or blended hydraulic cement as defined in ASTM C 219.
 - 2. Primer: Product of topping manufacturer recommended for substrate, conditions, and application.
 - 3. Aggregate: Well-graded, washed gravel, **1/8 to 1/4 inch (3.2 to 6 mm)** or coarse sand as recommended by topping manufacturer.
 - 4. Compressive Strength: Not less than **5000 psi (34.5 MPa)** at 28 days when tested according to ASTM C 109/C 109M.

2.11 CONCRETE MIXTURES, GENERAL

- A. Prepare design mixtures for each type and strength of concrete, proportioned on the basis of laboratory trial mixture or field test data, or both, according to **ACI 301 (ACI 301M)**.
 - 1. Use a qualified independent testing agency for preparing and reporting proposed mixture designs based on laboratory trial mixtures.
- B. Cementitious Materials: Limit percentage, by weight, of cementitious materials other than portland cement in concrete as follows:
 - 1. Fly Ash: 15 percent.

- C. Limit water-soluble, chloride-ion content in hardened concrete to 0.06 percent by weight of cement.
- D. Admixtures: Use admixtures according to manufacturer's written instructions.
 1. Use plasticizing admixture in concrete, as required, for placement and workability.
 2. Use water-reducing and -retarding admixture when required by high temperatures, low humidity, or other adverse placement conditions.
 3. Use water-reducing admixture in pumped concrete, with a w/c ratio below 0.50.
 4. Use corrosion-inhibiting admixture in concrete mixtures where indicated.

2.12 CONCRETE MIXTURES FOR BUILDING ELEMENTS

- A. Footings: Normal-weight concrete.
 1. Minimum Compressive Strength: 3,500 psi (24.1 MPa) at 28 days.
 2. Maximum W/C Ratio: 0.45.
 3. Slump Limit: 4 inches (100 mm), plus or minus 1 inch (25 mm).
- B. Slabs-on-Grade: Normal-weight concrete.
 1. Minimum Compressive Strength: 3,500 psi (24.1 MPa) at 28 days.
 2. Maximum W/C Ratio: 0.45.
 3. Minimum Cementitious Materials Content: 520 lb/cu. yd. (309 kg/cu. m).
 4. Slump Limit: 4 inches (100 mm), plus or minus 1 inch (25 mm).
 5. Air Content: Do not allow air content of trowel-finished floors to exceed 3 percent.

2.13 FABRICATING REINFORCEMENT

- A. Fabricate steel reinforcement according to CRSI's "Manual of Standard Practice."

2.14 CONCRETE MIXING

- A. Ready-Mixed Concrete: Measure, batch, mix, and deliver concrete according to ASTM C 94/C 94M, and furnish batch ticket information.
 1. When air temperature is between 85 and 90 deg F (30 and 32 deg C), reduce mixing and delivery time from 1-1/2 hours to 75 minutes; when air temperature is above 90 deg F (32 deg C), reduce mixing and delivery time to 60 minutes.

PART 3 - EXECUTION

3.1 FORMWORK INSTALLATION

- A. Design, erect, shore, brace, and maintain formwork, according to ACI 301 (ACI 301M), to support vertical, lateral, static, and dynamic loads, and construction loads that might be applied, until structure can support such loads.

- B. Construct formwork so concrete members and structures are of size, shape, alignment, elevation, and position indicated, within tolerance limits of ACI 117 (ACI 117M).
- C. Limit concrete surface irregularities, designated by ACI 347 as abrupt or gradual, as follows:
 - 1. Class A, 1/8 inch (3.2 mm) for smooth-formed finished surfaces.
 - 2. Class B, 1/4 inch (6 mm) for rough-formed finished surfaces.
- D. Construct forms tight enough to prevent loss of concrete mortar.
- E. Construct forms for easy removal without hammering or prying against concrete surfaces. Provide crush or wrecking plates where stripping may damage cast-concrete surfaces. Provide top forms for inclined surfaces steeper than 1.5 horizontal to 1 vertical.
 - 1. Install keyways, reglets, recesses, and the like, for easy removal.
 - 2. Do not use rust-stained steel form-facing material.
- F. Set edge forms, bulkheads, and intermediate screed strips for slabs to achieve required elevations and slopes in finished concrete surfaces. Provide and secure units to support screed strips; use strike-off templates or compacting-type screeds.
- G. Provide temporary openings for cleanouts and inspection ports where interior area of formwork is inaccessible. Close openings with panels tightly fitted to forms and securely braced to prevent loss of concrete mortar. Locate temporary openings in forms at inconspicuous locations.
- H. Chamfer exterior corners and edges of permanently exposed concrete.
- I. Form openings, chases, offsets, sinkages, keyways, reglets, blocking, screeds, and bulkheads required in the Work. Determine sizes and locations from trades providing such items.
- J. Clean forms and adjacent surfaces to receive concrete. Remove chips, wood, sawdust, dirt, and other debris just before placing concrete.
- K. Retighten forms and bracing before placing concrete, as required, to prevent mortar leaks and maintain proper alignment.
- L. Coat contact surfaces of forms with form-release agent, according to manufacturer's written instructions, before placing reinforcement.

3.2 EMBEDDED ITEM INSTALLATION

- A. Place and secure anchorage devices and other embedded items required for adjoining work that is attached to or supported by cast-in-place concrete. Use setting drawings, templates, diagrams, instructions, and directions furnished with items to be embedded.
 - 1. Install anchor rods, accurately located, to elevations required and complying with tolerances in Section 7.5 of AISC 303.

3.3 REMOVING AND REUSING FORMS

- A. General: Formwork for sides of beams, walls, columns, and similar parts of the Work that does not support weight of concrete may be removed after cumulatively curing at not less than 50 deg F (10 deg C) for 24 hours after placing concrete. Concrete has to be hard enough to not be damaged by form-removal operations, and curing and protection operations need to be maintained.
 - 1. Leave formwork for beam soffits, joists, slabs, and other structural elements that support weight of concrete in place until concrete has achieved at least 70 percent of its 28-day design compressive strength.
 - 2. Remove forms only if shores have been arranged to permit removal of forms without loosening or disturbing shores.
- B. Clean and repair surfaces of forms to be reused in the Work. Split, frayed, delaminated, or otherwise damaged form-facing material are not acceptable for exposed surfaces. Apply new form-release agent.
- C. When forms are reused, clean surfaces, remove fins and laitance, and tighten to close joints. Align and secure joints to avoid offsets. Do not use patched forms for exposed concrete surfaces unless approved by Architect.

3.4 VAPOR-RETARDER INSTALLATION

- A. Sheet Vapor Retarders: Place, protect, and repair sheet vapor retarder according to ASTM E 1643 and manufacturer's written instructions.
 - 1. Lap joints 6 inches (150 mm) and seal with manufacturer's recommended tape.
- B. Bituminous Vapor Retarders: Place, protect, and repair bituminous vapor retarder according to manufacturer's written instructions.

3.5 STEEL REINFORCEMENT INSTALLATION

- A. General: Comply with CRSI's "Manual of Standard Practice" for fabricating, placing, and supporting reinforcement.
 - 1. Do not cut or puncture vapor retarder. Repair damage and reseal vapor retarder before placing concrete.
- B. Clean reinforcement of loose rust and mill scale, earth, ice, and other foreign materials that reduce bond to concrete.
- C. Accurately position, support, and secure reinforcement against displacement. Locate and support reinforcement with bar supports to maintain minimum concrete cover. Do not tack weld crossing reinforcing bars.
 - 1. Weld reinforcing bars according to AWS D1.4/D 1.4M, where indicated.
- D. Set wire ties with ends directed into concrete, not toward exposed concrete surfaces.

3.6 JOINTS

- A. General: Construct joints true to line with faces perpendicular to surface plane of concrete.
- B. Construction Joints: Install so strength and appearance of concrete are not impaired, at locations indicated or as approved by Architect.
 - 1. Place joints perpendicular to main reinforcement. Continue reinforcement across construction joints unless otherwise indicated. Do not continue reinforcement through sides of strip placements of floors and slabs.
 - 2. Locate joints for beams, slabs, joists, and girders in the middle third of spans. Offset joints in girders a minimum distance of twice the beam width from a beam-girder intersection.
 - 3. Locate horizontal joints in walls and columns at underside of floors, slabs, beams, and girders and at the top of footings or floor slabs.
 - 4. Use epoxy-bonding adhesive at locations where fresh concrete is placed against hardened or partially hardened concrete surfaces.
- C. Contraction Joints in Slabs-on-Grade: Form weakened-plane contraction joints, sectioning concrete into areas as indicated. Construct contraction joints for a depth equal to at least one-fourth of concrete thickness as follows:
 - 1. Grooved Joints: Form contraction joints after initial floating by grooving and finishing each edge of joint to a radius of **1/8 inch (3.2 mm)**. Repeat grooving of contraction joints after applying surface finishes. Eliminate groover tool marks on concrete surfaces.
 - 2. Sawed Joints: Form contraction joints with power saws equipped with shatterproof abrasive or diamond-rimmed blades. Cut **1/8-inch- (3.2-mm-)** wide joints into concrete when cutting action does not tear, abrade, or otherwise damage surface and before concrete develops random contraction cracks.

3.7 CONCRETE PLACEMENT

- A. Before placing concrete, verify that installation of formwork, reinforcement, and embedded items is complete and that required inspections are completed.
- B. Do not add water to concrete during delivery, at Project site, or during placement unless approved by Engineer of Record.
- C. Deposit concrete continuously in one layer or in horizontal layers of such thickness that no new concrete is placed on concrete that has hardened enough to cause seams or planes of weakness. If a section cannot be placed continuously, provide construction joints as indicated. Deposit concrete to avoid segregation.
 - 1. Deposit concrete in horizontal layers of depth not to exceed formwork design pressures and in a manner to avoid inclined construction joints.
 - 2. Consolidate placed concrete with mechanical vibrating equipment according to **ACI 301 (ACI 301M)**.
 - 3. Do not use vibrators to transport concrete inside forms. Insert and withdraw vibrators vertically at uniformly spaced locations to rapidly penetrate placed layer and at least **6 inches (150 mm)** into preceding layer. Do not insert vibrators into lower layers of concrete that have begun to lose plasticity. At each insertion, limit duration of

vibration to time necessary to consolidate concrete and complete embedment of reinforcement and other embedded items without causing mixture constituents to segregate.

- D. Deposit and consolidate concrete for floors and slabs in a continuous operation, within limits of construction joints, until placement of a panel or section is complete.
 - 1. Consolidate concrete during placement operations, so concrete is thoroughly worked around reinforcement and other embedded items and into corners.
 - 2. Maintain reinforcement in position on chairs during concrete placement.
 - 3. Screed slab surfaces with a straightedge and strike off to correct elevations.
 - 4. Slope surfaces uniformly to drains where required.
 - 5. Begin initial floating using bull floats or darbies to form a uniform and open-textured surface plane, before excess bleedwater appears on the surface. Do not further disturb slab surfaces before starting finishing operations.

3.8 FINISHING FORMED SURFACES

- A. Rough-Formed Finish: As-cast concrete texture imparted by form-facing material with tie holes and defects repaired and patched. Remove fins and other projections that exceed specified limits on formed-surface irregularities.
 - 1. Apply to concrete surfaces not exposed to public view.
- B. Smooth-Formed Finish: As-cast concrete texture imparted by form-facing material, arranged in an orderly and symmetrical manner with a minimum of seams. Repair and patch tie holes and defects. Remove fins and other projections that exceed specified limits on formed-surface irregularities.
 - 1. Apply to concrete surfaces exposed to public view.
- C. Related Unformed Surfaces: At tops of walls, horizontal offsets, and similar unformed surfaces adjacent to formed surfaces, strike off smooth and finish with a texture matching adjacent formed surfaces. Continue final surface treatment of formed surfaces uniformly across adjacent unformed surfaces unless otherwise indicated.

3.9 FINISHING FLOORS AND SLABS

- A. General: Comply with ACI 302.1R recommendations for screeding, restraighening, and finishing operations for concrete surfaces. Do not wet concrete surfaces.
- B. Float Finish: Consolidate surface with power-driven floats or by hand floating if area is small or inaccessible to power-driven floats. Restraighten, cut down high spots, and fill low spots. Repeat float passes and restraighening until surface is left with a uniform, smooth, granular texture.
 - 1. Apply float finish to surfaces to receive trowel finish.
- C. Trowel Finish: After applying float finish, apply first troweling and consolidate concrete by hand or power-driven trowel. Continue troweling passes and restraighten until surface is free of trowel marks and uniform in texture and appearance. Grind smooth any surface defects that would telegraph through applied coatings or floor coverings.

1. Apply a trowel finish to all slab surfaces.
 2. Finish and measure surface, so gap at any point between concrete surface and an unlevelled, freestanding, 10-ft.- (3.05-m-) long straightedge resting on two high spots and placed anywhere on the surface does not exceed 1/8 inch (3.2 mm).
- D. Trowel and Fine-Broom Finish: Apply a first trowel finish to surfaces indicated. While concrete is still plastic, slightly scarify surface with a fine broom.
1. Comply with flatness and levelness tolerances for trowel-finished floor surfaces.

3.10 MISCELLANEOUS CONCRETE ITEM INSTALLATION

- A. Filling In: Fill in holes and openings left in concrete structures after work of other trades is in place unless otherwise indicated. Mix, place, and cure concrete, as specified, to blend with in-place construction. Provide other miscellaneous concrete filling indicated or required to complete the Work.
- B. Curbs: Provide monolithic finish to interior curbs by stripping forms while concrete is still green and by steel-troweling surfaces to a hard, dense finish with corners, intersections, and terminations slightly rounded.
- C. Equipment Bases and Foundations:
1. Coordinate sizes and locations of concrete bases with actual equipment provided.
 2. Construct concrete bases 4 inches (100 mm) high unless otherwise indicated, and extend base not less than 6 inches (150 mm) in each direction beyond the maximum dimensions of supported equipment unless otherwise indicated or unless required for seismic anchor support.
 3. Minimum Compressive Strength: 3500 psi (24.1 MPa) at 28 days.
 4. Install dowel rods to connect concrete base to concrete floor. Unless otherwise indicated, install dowel rods on 18-inch (450-mm) centers around the full perimeter of concrete base.
 5. For supported equipment, install post-installed anchor bolts that extend through concrete base and anchor into structural concrete substrate. Anchor bolt type as indicated on Drawings.
 6. Prior to pouring concrete, place and secure anchorage devices. Use setting drawings, templates, diagrams, instructions, and directions furnished with items to be embedded.
 7. Cast anchor-bolt insert into bases. Install anchor bolts to elevations required for proper attachment to supported equipment.

3.11 CONCRETE PROTECTING AND CURING

- A. General: Protect freshly placed concrete from premature drying and excessive cold or hot temperatures. Comply with ACI 306.1 for cold-weather protection and ACI 305.1 (ACI 305.1M) for hot-weather protection during curing.
- B. Evaporation Retarder: Apply evaporation retarder to unformed concrete surfaces if hot, dry, or windy conditions cause moisture loss approaching 0.2 lb/sq. ft. x h (1 kg/sq. m x h) before and during finishing operations. Apply according to manufacturer's written

instructions after placing, screeding, and bull floating or darbying concrete, but before float finishing.

- C. Formed Surfaces: Cure formed concrete surfaces, including underside of beams, supported slabs, and other similar surfaces. If forms remain during curing period, moist cure after loosening forms. If removing forms before end of curing period, continue curing for remainder of curing period.
- D. Unformed Surfaces: Begin curing immediately after finishing concrete. Cure unformed surfaces, including floors and slabs, concrete floor toppings, and other surfaces.
- E. Cure concrete according to ACI 308.1, by one or a combination of the following methods:
 - 1. Moisture Curing: Keep surfaces continuously moist for not less than seven days with the following materials:
 - a. Water.
 - b. Continuous water-fog spray.
 - c. Absorptive cover, water saturated, and kept continuously wet. Cover concrete surfaces and edges with 12-inch (300-mm) lap over adjacent absorptive covers.
 - 2. Moisture-Retaining-Cover Curing: Cover concrete surfaces with moisture-retaining cover for curing concrete, placed in widest practicable width, with sides and ends lapped at least 12 inches (300 mm), and sealed by waterproof tape or adhesive. Cure for not less than seven days. Immediately repair any holes or tears during curing period, using cover material and waterproof tape.
 - a. Moisture cure or use moisture-retaining covers to cure concrete surfaces to receive floor coverings.
 - b. Moisture cure or use moisture-retaining covers to cure concrete surfaces to receive penetrating liquid floor treatments.
 - c. Cure concrete surfaces to receive floor coverings with either a moisture-retaining cover or a curing compound that the manufacturer certifies does not interfere with bonding of floor covering used on Project.

3.12 LIQUID FLOOR TREATMENT APPLICATION

- A. Penetrating Liquid Floor Treatment: Prepare, apply, and finish penetrating liquid floor treatment according to manufacturer's written instructions.
 - 1. Remove curing compounds, sealers, oil, dirt, laitance, and other contaminants and complete surface repairs.
 - 2. Do not apply to concrete that is less than 14 days' old, unless otherwise stated in manufacturer's written instructions.
 - 3. Apply liquid until surface is saturated, scrubbing into surface until a gel forms; rewet; and repeat brooming or scrubbing. Rinse with water; remove excess material until surface is dry. Apply a second coat in a similar manner if surface is rough or porous.

3.13 JOINT FILLING

- A. Prepare, clean, and install joint filler according to manufacturer's written instructions.

1. Defer joint filling until concrete has aged at least one month. Do not fill joints until construction traffic has permanently ceased.
- B. Remove dirt, debris, saw cuttings, curing compounds, and sealers from joints; leave contact faces of joints clean and dry.
- C. Install semirigid joint filler full depth in saw-cut joints and at least **2 inches (50 mm)** deep in formed joints. Overfill joint and trim joint filler flush with top of joint after hardening.

3.14 CONCRETE SURFACE REPAIRS

- A. Defective Concrete: Repair and patch defective areas when approved by Engineer. Remove and replace concrete that cannot be repaired and patched to Engineer's approval.
- B. Patching Mortar: Mix dry-pack patching mortar, consisting of 1 part portland cement to 2-1/2 parts fine aggregate passing a **No. 16 (1.18-mm)** sieve, using only enough water for handling and placing.
- C. Repairing Formed Surfaces: Surface defects include color and texture irregularities, cracks, spalls, air bubbles, honeycombs, rock pockets, fins and other projections on the surface, and stains and other discolorations that cannot be removed by cleaning.
 1. Immediately after form removal, cut out honeycombs, rock pockets, and voids more than **1/2 inch (13 mm)** in any dimension to solid concrete. Limit cut depth to **3/4 inch (19 mm)**. Make edges of cuts perpendicular to concrete surface. Clean, dampen with water, and brush-coat holes and voids with bonding agent. Fill and compact with patching mortar before bonding agent has dried. Fill form-tie voids with patching mortar or cone plugs secured in place with bonding agent.
 2. Repair defects on surfaces exposed to view by blending white portland cement and standard portland cement so that, when dry, patching mortar matches surrounding color. Patch a test area at inconspicuous locations to verify mixture and color match before proceeding with patching. Compact mortar in place and strike off slightly higher than surrounding surface.
 3. Repair defects on concealed formed surfaces that affect concrete's durability and structural performance as determined by Architect.
- D. Repairing Unformed Surfaces: Test unformed surfaces, such as floors and slabs, for finish and verify surface tolerances specified for each surface. Correct low and high areas. Test surfaces sloped to drain for trueness of slope and smoothness; use a sloped template.
 1. Repair finished surfaces containing defects. Surface defects include spalls, popouts, honeycombs, rock pockets, crazing and cracks in excess of **0.01 inch (0.25 mm)** wide or that penetrate to reinforcement or completely through unreinforced sections regardless of width, and other objectionable conditions.
 2. After concrete has cured at least 14 days, correct high areas by grinding.
 3. Correct localized low areas during or immediately after completing surface finishing operations by cutting out low areas and replacing with patching mortar. Finish repaired areas to blend into adjacent concrete.
 4. Correct other low areas scheduled to remain exposed with a repair topping. Cut out low areas to ensure a minimum repair topping depth of **1/4 inch (6 mm)** to match adjacent floor elevations. Prepare, mix, and apply repair topping and primer

according to manufacturer's written instructions to produce a smooth, uniform, plane, and level surface.

5. Repair defective areas, except random cracks and single holes **1 inch (25 mm)** or less in diameter, by cutting out and replacing with fresh concrete. Remove defective areas with clean, square cuts and expose steel reinforcement with at least a **3/4-inch (19-mm)** clearance all around. Dampen concrete surfaces in contact with patching concrete and apply bonding agent. Mix patching concrete of same materials and mixture as original concrete, except without coarse aggregate. Place, compact, and finish to blend with adjacent finished concrete. Cure in same manner as adjacent concrete.
 6. Repair random cracks and single holes **1 inch (25 mm)** or less in diameter with patching mortar. Groove top of cracks and cut out holes to sound concrete and clean off dust, dirt, and loose particles. Dampen cleaned concrete surfaces and apply bonding agent. Place patching mortar before bonding agent has dried. Compact patching mortar and finish to match adjacent concrete. Keep patched area continuously moist for at least 72 hours.
- E. Perform structural repairs of concrete, subject to Architect's approval, using epoxy adhesive and patching mortar.
- F. Repair materials and installation not specified above may be used, subject to Engineer's approval.

3.15 FIELD QUALITY CONTROL

- A. Testing Agency: Engage a qualified testing and inspecting agency to perform tests and inspections and to submit reports.
- B. Inspections:
1. Steel reinforcement placement.
 2. Steel reinforcement welding.
 3. Headed bolts and studs.
 4. Verification of use of required design mixture.
 5. Concrete placement, including conveying and depositing.
 6. Curing procedures and maintenance of curing temperature.
 7. Verification of concrete strength before removal of shores and forms from beams and slabs.
 8. As indicated in Drawings – Summary of Special Inspection – Sheets S1.3 and S1.4.
- C. Concrete Tests: Testing of composite samples of fresh concrete obtained according to ASTM C 172/C 172M shall be performed according to the following requirements:
1. Testing Frequency: Obtain at least one composite sample for each **50 cu. yd. (38 cu. m)** or fraction thereof of each concrete mixture placed each day.
 - a. When frequency of testing provides fewer than five compressive-strength tests for each concrete mixture, testing shall be conducted from at least five randomly selected batches or from each batch if fewer than five are used.
 2. Slump: ASTM C 143/C 143M; one test at point of placement for each composite sample, but not less than one test for each day's pour of each concrete mixture. Perform additional tests when concrete consistency appears to change.

3. Air Content: ASTM C 231/C 231M, pressure method, for normal-weight concrete; one test for each composite sample, but not less than one test for each day's pour of each concrete mixture.
4. Concrete Temperature: ASTM C 1064/C 1064M; one test hourly when air temperature is 40 deg F (4.4 deg C) and below or 80 deg F (27 deg C) and above, and one test for each composite sample.
5. Compression Test Specimens: ASTM C 31/C 31M.
 - a. Cast and laboratory cure two sets of two standard cylinder specimens for each composite sample.
6. Compressive-Strength Tests: ASTM C 39/C 39M; test one set of two laboratory-cured specimens at 7 days and one set of two specimens at 28 days.
 - a. A compressive-strength test shall be the average compressive strength from a set of two specimens obtained from same composite sample and tested at age indicated.
7. Strength of each concrete mixture will be satisfactory if every average of any three consecutive compressive-strength tests equals or exceeds specified compressive strength and no compressive-strength test value falls below specified compressive strength by more than 500 psi (3.4 MPa).
8. Test results shall be reported in writing to Architect, concrete manufacturer, and Contractor within 48 hours of testing. Reports of compressive-strength tests shall contain Project identification name and number, date of concrete placement, name of concrete testing and inspecting agency, location of concrete batch in Work, design compressive strength at 28 days, concrete mixture proportions and materials, compressive breaking strength, and type of break for both 7- and 28-day tests.
9. Nondestructive Testing: Impact hammer, sonoscope, or other nondestructive device may be permitted by Architect but will not be used as sole basis for approval or rejection of concrete.
10. Additional Tests: Testing and inspecting agency shall make additional tests of concrete when test results indicate that slump, air entrainment, compressive strengths, or other requirements have not been met, as directed by Architect. Testing and inspecting agency may conduct tests to determine adequacy of concrete by cored cylinders complying with ASTM C 42/C 42M or by other methods as directed by Architect.
11. Additional testing and inspecting, at Contractor's expense, will be performed to determine compliance of replaced or additional work with specified requirements.
12. Correct deficiencies in the Work that test reports and inspections indicate do not comply with the Contract Documents.

3.16 PROTECTION OF LIQUID FLOOR TREATMENTS

- A. Protect liquid floor treatment from damage and wear during the remainder of construction period. Use protective methods and materials, including temporary covering, recommended in writing by liquid floor treatments installer.

END OF SECTION 033000

SECTION 042200

CONCRETE UNIT MASONRY

3.17 RELATED DOCUMENTS

- A. Drawings and general provisions of the Contract - Standard Specifications for Public Works Construction 'The GREENBOOK' and City Supplement 'The WHITEBOOK', latest editions, including Supplemental Supplementary Provisions (SSPs), apply to this Section.

3.18 SUMMARY

- A. Section Includes:

1. Concrete masonry units.
2. Decorative concrete masonry units.
3. Mortar and grout.
4. Steel reinforcing bars.
5. Masonry-joint reinforcement.
6. Miscellaneous masonry accessories.

- B. Related Requirements:

1. Section 099600 "High-Performance Coatings" for anti-graffiti coatings applied to unit masonry assemblies.

3.19 DEFINITIONS

- A. CMU(s): Concrete masonry unit(s).
- B. Reinforced Masonry: Masonry containing reinforcing steel in grouted cells.

3.20 PREINSTALLATION MEETINGS

- A. Preinstallation Conference: Conduct conference at Project site.

3.21 ACTION SUBMITTALS

- A. Product Data: For each type of product.
- B. Shop Drawings: For the following:
 1. Masonry Units: Show sizes, profiles, coursing, and locations of special shapes.
 2. Reinforcing Steel: Detail bending, lap lengths, and placement of unit masonry reinforcing bars. Comply with ACI 315. Show elevations of reinforced walls.
- C. Samples for Initial Selection:
 1. Colored mortar.
 - a. Provide mortar matching block color.

- D. Samples for Verification: For each type and color of the following:
 - 1. Exposed CMUs.
 - a. Each color used on project, Precision Face.
 - b. Burnished Face.
 - 2. Pigmented mortar. Make Samples using same sand and mortar ingredients to be used on Project.

3.22 INFORMATIONAL SUBMITTALS

- A. Qualification Data: For testing agency.
- B. Material Certificates: For each type and size of the following:
 - 1. Masonry units.
 - a. Include data on material properties and material test reports substantiating compliance with requirements.
 - b. For masonry units, include data and calculations establishing average net-area compressive strength of units.
 - 2. Cementitious materials. Include name of manufacturer, brand name, and type.
 - 3. Mortar admixtures.
 - 4. Preblended, dry mortar mixes. Include description of type and proportions of ingredients.
 - 5. Grout mixes. Include description of type and proportions of ingredients.
 - 6. Reinforcing bars.
 - 7. Joint reinforcement.
 - 8. Anchors, ties, and metal accessories.
- C. Mix Designs: For each type of mortar and grout. Include description of type and proportions of ingredients.
 - 1. Include test reports for mortar mixes required to comply with property specification. Test according to ASTM C 109/C 109M for compressive strength, ASTM C 1506 for water retention, and ASTM C 91/C 91M for air content.
 - 2. Include test reports, according to ASTM C 1019, for grout mixes required to comply with compressive strength requirement.
- D. Statement of Compressive Strength of Masonry: For each combination of masonry unit type and mortar type, provide statement of average net-area compressive strength of masonry units, mortar type, and resulting net-area compressive strength of masonry determined according to TMS 602/ACI 530.1/ASCE 6.
- E. Cold-Weather and Hot-Weather Procedures: Detailed description of methods, materials, and equipment to be used to comply with requirements.

3.23 QUALITY ASSURANCE

- A. Testing Agency Qualifications: Qualified according to ASTM C 1093 for testing indicated.

3.24 DELIVERY, STORAGE, AND HANDLING

- A. Store masonry units on elevated platforms in a dry location. If units are not stored in an enclosed location, cover tops and sides of stacks with waterproof sheeting, securely tied. If units become wet, do not install until they are dry.
- B. Store cementitious materials on elevated platforms, under cover, and in a dry location. Do not use cementitious materials that have become damp.
- C. Store aggregates where grading and other required characteristics can be maintained and contamination avoided.
- D. Deliver preblended, dry mortar mix in moisture-resistant containers. Store preblended, dry mortar mix in delivery containers on elevated platforms in a dry location or in covered weatherproof dispensing silos.
- E. Store masonry accessories, including metal items, to prevent corrosion and accumulation of dirt and oil.

3.25 FIELD CONDITIONS

- A. Protection of Masonry: During construction, cover tops of walls, projections, and sills with waterproof sheeting at end of each day's work. Cover partially completed masonry when construction is not in progress.
 - 1. Extend cover a minimum of **24 inches (600 mm)** down both sides of walls, and hold cover securely in place.
- B. Do not apply uniform floor or roof loads for at least 12 hours and concentrated loads for at least three days after building masonry walls or columns.
- C. Stain Prevention: Prevent grout, mortar, and soil from staining the face of masonry to be left exposed or painted. Immediately remove grout, mortar, and soil that come in contact with such masonry.
 - 1. Protect base of walls from rain-splashed mud and from mortar splatter by spreading coverings on ground and over wall surface.
 - 2. Protect sills, ledges, and projections from mortar droppings.
 - 3. Protect surfaces of window and door frames, as well as similar products with painted and integral finishes, from mortar droppings.
 - 4. Turn scaffold boards near the wall on edge at the end of each day to prevent rain from splashing mortar and dirt onto completed masonry.
- D. Cold-Weather Requirements: Do not use frozen materials or materials mixed or coated with ice or frost. Do not build on frozen substrates. Remove and replace unit masonry damaged by frost or by freezing conditions. Comply with cold-weather construction requirements contained in TMS 602/ACI 530.1/ASCE 6.
 - 1. Cold-Weather Cleaning: Use liquid cleaning methods only when air temperature is **40 deg F (4 deg C)** and higher and will remain so until masonry has dried, but not less than seven days after completing cleaning.

- E. Hot-Weather Requirements: Comply with hot-weather construction requirements contained in TMS 602/ACI 530.1/ASCE 6.

PART 4 - PRODUCTS

4.1 MANUFACTURERS

- A. Source Limitations for Masonry Units: Obtain exposed masonry units of a uniform texture and color, or a uniform blend within the ranges accepted for these characteristics, from single source from single manufacturer for each product required.
- B. Source Limitations for Mortar Materials: Obtain mortar ingredients of a uniform quality, including color for exposed masonry, from single manufacturer for each cementitious component and from single source or producer for each aggregate.

4.2 PERFORMANCE REQUIREMENTS

- A. Provide unit masonry that develops indicated net-area compressive strengths at 28 days.
 - 1. Determine net-area compressive strength of masonry from average net-area compressive strengths of masonry units and mortar types (unit-strength method) according to TMS 602/ACI 530.1/ASCE 6.
 - 2. Determine net-area compressive strength of masonry by testing masonry prisms according to ASTM C 1314.

4.3 UNIT MASONRY, GENERAL

- A. Masonry Standard: Comply with TMS 602/ACI 530.1/ASCE 6 except as modified by requirements in the Contract Documents.
- B. Defective Units: Referenced masonry unit standards may allow a certain percentage of units to contain chips, cracks, or other defects exceeding limits stated. Do not use units where such defects are exposed in the completed Work and will be within 20 feet (6 m) vertically and horizontally of a walking surface.

4.4 CONCRETE MASONRY UNITS

- A. Shapes: Provide shapes indicated and as follows, with exposed surfaces matching exposed faces of adjacent units unless otherwise indicated.
 - 1. Provide special shapes for lintels, corners, jambs, sashes, movement joints, headers, bonding, and other special conditions.
 - 2. Provide bullnose units for outside corners unless otherwise indicated.
- B. CMUs: ASTM C 90.
 - 1. Unit Compressive Strength: Provide units with minimum average net-area compressive strength of 2150 psi (14.8 MPa).
 - 2. Density Classification: Normal weight unless otherwise indicated.

3. Size (Width): Manufactured to dimensions **3/8 inch (10 mm)** less-than-nominal dimensions.
 4. Exposed Faces: Provide color and texture matching the range represented by Engineer's sample.
- C. Decorative CMUs: ASTM C 90.
1. Unit Compressive Strength: Provide units with minimum average net-area compressive strength of **2150 psi (14.8 MPa)**.
 2. Density Classification: Normal weight.
 3. Size (Width): Manufactured to dimensions specified in "CMUs" Paragraph.
 4. Pattern and Texture:
 - a. Standard pattern, burnished face finish. Match Architect's samples.
 5. Colors: Match Engineer's samples.

4.5 MASONRY LINTELS

- A. Masonry Lintels: Built-in-place masonry lintels made from bond beam CMUs matching adjacent CMUs in color, texture, and density classification, with reinforcing bars placed as indicated and filled with coarse grout. Cure precast lintels before handling and installing. Temporarily support built-in-place lintels until cured.

4.6 MORTAR AND GROUT MATERIALS

- A. Portland Cement: ASTM C 150/C 150M, Type I or II, except Type III may be used for cold-weather construction. Provide natural color or white cement as required to produce mortar color indicated.
1. Alkali content shall not be more than 0.1 percent when tested according to ASTM C 114.
- B. Hydrated Lime: ASTM C 207, Type S.
- C. Portland Cement-Lime Mix: Packaged blend of portland cement and hydrated lime containing no other ingredients.
- D. Masonry Cement: ASTM C 91/C 91M.
- E. Mortar Pigments: Natural and synthetic iron oxides and chromium oxides, compounded for use in mortar mixes and complying with ASTM C 979/C 979M. Use only pigments with a record of satisfactory performance in masonry mortar.
- F. Colored Cement Products: Packaged blend made from masonry cement and mortar pigments, all complying with specified requirements, and containing no other ingredients.
1. Colored Masonry Cement:
 2. Formulate blend as required to produce color indicated or, if not indicated, as selected from manufacturer's standard colors.
 3. Pigments shall not exceed 10 percent of portland cement by weight.
 4. Pigments shall not exceed 5 percent of masonry cement by weight.

- G. Aggregate for Mortar: ASTM C 144.
 1. For mortar that is exposed to view, use washed aggregate consisting of natural sand or crushed stone.
 2. For joints less than **1/4 inch (6 mm)** thick, use aggregate graded with 100 percent passing the **No. 16 (1.18-mm)** sieve.
 3. White-Mortar Aggregates: Natural white sand or crushed white stone.
 4. Colored-Mortar Aggregates: Natural sand or crushed stone of color necessary to produce required mortar color.
- H. Aggregate for Grout: ASTM C 404.
- I. Epoxy Pointing Mortar: ASTM C 395, epoxy-resin-based material formulated for use as pointing mortar for glazed or pre-faced masonry units (and approved for such use by manufacturer of units); in color indicated or, if not otherwise indicated, as selected by Architect from manufacturer's colors.
- J. Cold-Weather Admixture: Nonchloride, noncorrosive, accelerating admixture complying with ASTM C 494/C 494M, Type C, and recommended by manufacturer for use in masonry mortar of composition indicated.
- K. Water: Potable.

4.7 REINFORCEMENT

- A. Uncoated Steel Reinforcing Bars: ASTM A 615/A 615M or ASTM A 996/A 996M, **Grade 60 (Grade 420)**.
- B. Reinforcing Bar Positioners: Wire units designed to fit into mortar bed joints spanning masonry unit cells and to hold reinforcing bars in center of cells. Units are formed from **0.148-inch (3.77-mm)** steel wire, hot-dip galvanized after fabrication. Provide units designed for number of bars indicated.

4.8 MISCELLANEOUS MASONRY ACCESSORIES

- A. Compressible Filler: Premolded filler strips complying with ASTM D 1056, Grade 2A1; compressible up to 35 percent; of width and thickness indicated; formulated from neoprene, urethane or PVC.
- B. Preformed Control-Joint Gaskets: Made from styrene-butadiene-rubber compound, complying with ASTM D 2000, Designation M2AA-805 or PVC, complying with ASTM D 2287, Type PVC-65406 and designed to fit standard sash block and to maintain lateral stability in masonry wall; size and configuration as indicated.
- C. Bond-Breaker Strips: Asphalt-saturated felt complying with ASTM D 226/D 226M, Type I (No. 15 asphalt felt).

4.9 MORTAR AND GROUT MIXES

- A. General: Do not use admixtures, including pigments, air-entraining agents, accelerators, retarders, water-repellent agents, antifreeze compounds, or other admixtures unless otherwise indicated.
1. Do not use calcium chloride in mortar or grout.
 2. Use masonry cement mortar unless otherwise indicated.
 3. Add cold-weather admixture (if used) at same rate for all mortar that will be exposed to view, regardless of weather conditions, to ensure that mortar color is consistent.
- B. Preblended, Dry Mortar Mix: Furnish dry mortar ingredients in form of a preblended mix. Measure quantities by weight to ensure accurate proportions, and thoroughly blend ingredients before delivering to Project site.
- C. Mortar for Unit Masonry: Comply with ASTM C 270, Proportion Specification. Provide the following types of mortar for applications stated unless another type is indicated or needed to provide required compressive strength of masonry.
1. For masonry below grade or in contact with earth, use Type S.
 2. For reinforced masonry, use Type S.
 3. For mortar parge coats, use Type S.
 4. For exterior, above-grade, load-bearing and nonload-bearing walls and parapet walls; for interior load-bearing walls; for interior nonload-bearing partitions; and for other applications where another type is not indicated, use Type S.
- D. Pigmented Mortar: Use colored cement product.
1. Application: Use pigmented mortar for exposed mortar joints.
- E. Colored-Aggregate Mortar: Produce required mortar color by using colored aggregates and natural color or white cement as necessary to produce required mortar color.
1. Mix to match Engineer's sample.
 2. Application: Use colored-aggregate mortar for exposed mortar joints.
- F. Grout for Unit Masonry: Comply with ASTM C 476.
1. Use grout of type indicated or, if not otherwise indicated, of type (fine or coarse) that will comply with TMS 602/ACI 530.1/ASCE 6 for dimensions of grout spaces and pour height.
 2. Proportion grout in accordance with ASTM C 476, paragraph 4.2.2 for specified 28-day compressive strength indicated, but not less than **2500 psi (14 MPa)**.
 3. Provide grout with a slump of **8 to 11 inches (200 to 280 mm)** as measured according to ASTM C 143/C 143M.
- G. Epoxy Pointing Mortar: Mix epoxy pointing mortar to comply with mortar manufacturer's written instructions.
1. Application: Use epoxy pointing mortar for exposed mortar joints with pre-faced CMUs.

PART 5 - EXECUTION

5.1 EXAMINATION

- A. Examine conditions, with Installer present, for compliance with requirements for installation tolerances and other conditions affecting performance of the Work.
 - 1. For the record, prepare written report, endorsed by Installer, listing conditions detrimental to performance of the Work.
 - 2. Verify that foundations are within tolerances specified.
 - 3. Verify that reinforcing dowels are properly placed.
 - 4. Verify that substrates are free of substances that would impair mortar bond.
- B. Before installation, examine rough-in and built-in construction for piping systems to verify actual locations of piping.
- C. Proceed with installation only after unsatisfactory conditions have been corrected.

5.2 INSTALLATION, GENERAL

- A. Build chases and recesses to accommodate items specified in this and other Sections.
- B. Leave openings for equipment to be installed before completing masonry. After installing equipment, complete masonry to match construction immediately adjacent to opening.
- C. Use full-size units without cutting if possible. If cutting is required to provide a continuous pattern or to fit adjoining construction, cut units with motor-driven saws; provide clean, sharp, unchipped edges. Allow units to dry before laying unless wetting of units is specified. Install cut units with cut surfaces and, where possible, cut edges concealed.

5.3 TOLERANCES

- A. Dimensions and Locations of Elements:
 - 1. For dimensions in cross section or elevation, do not vary by more than plus **1/2 inch (12 mm)** or minus **1/4 inch (6 mm)**.
 - 2. For location of elements in plan, do not vary from that indicated by more than plus or minus **1/2 inch (12 mm)**.
 - 3. For location of elements in elevation, do not vary from that indicated by more than plus or minus **1/4 inch (6 mm)** in a story height or **1/2 inch (12 mm)** total.
- B. Lines and Levels:
 - 1. For bed joints and top surfaces of bearing walls, do not vary from level by more than **1/4 inch in 10 feet (6 mm in 3 m)**, or **1/2-inch (12-mm)** maximum.
 - 2. For conspicuous horizontal lines, such as lintels, sills, parapets, and reveals, do not vary from level by more than **1/8 inch in 10 feet (3 mm in 3 m)**, **1/4 inch in 20 feet (6 mm in 6 m)**, or **1/2-inch (12-mm)** maximum.
 - 3. For vertical lines and surfaces do not vary from plumb by more than **1/4 inch in 10 feet (6 mm in 3 m)**, **3/8 inch in 20 feet (9 mm in 6 m)**, or **1/2-inch (12-mm)** maximum.

4. For conspicuous vertical lines, such as external corners, door jambs, reveals, and expansion and control joints, do not vary from plumb by more than **1/8 inch in 10 feet (3 mm in 3 m)**, **1/4 inch in 20 feet (6 mm in 6 m)**, or **1/2-inch (12-mm)** maximum.
5. For lines and surfaces, do not vary from straight by more than **1/4 inch in 10 feet (6 mm in 3 m)**, **3/8 inch in 20 feet (9 mm in 6 m)**, or **1/2-inch (12-mm)** maximum.
6. For vertical alignment of exposed head joints, do not vary from plumb by more than **1/4 inch in 10 feet (6 mm in 3 m)**, or **1/2-inch (12-mm)** maximum.
7. For faces of adjacent exposed masonry units, do not vary from flush alignment by more than **1/16 inch (1.5 mm)**.

C. Joints:

1. For bed joints, do not vary from thickness indicated by more than plus or minus **1/8 inch (3 mm)**, with a maximum thickness limited to **1/2 inch (12 mm)**.
2. For exposed bed joints, do not vary from bed-joint thickness of adjacent courses by more than **1/8 inch (3 mm)**.
3. For head and collar joints, do not vary from thickness indicated by more than plus **3/8 inch (9 mm)** or minus **1/4 inch (6 mm)**.
4. For exposed head joints, do not vary from thickness indicated by more than plus or minus **1/8 inch (3 mm)**.

5.4 LAYING MASONRY WALLS

- A. Lay out walls in advance for accurate spacing of surface bond patterns with uniform joint thicknesses and for accurate location of openings, movement-type joints, returns, and offsets. Avoid using less-than-half-size units, particularly at corners, jambs, and, where possible, at other locations.
- B. Bond Pattern for Exposed Masonry: Unless otherwise indicated, lay exposed masonry in bond pattern indicated on Drawings; do not use units with less-than-nominal **4-inch (100-mm)** horizontal face dimensions at corners or jambs.
- C. Lay concealed masonry with all units in a wythe in running bond or bonded by lapping not less than **4 inches (100 mm)**. Bond and interlock each course of each wythe at corners. Do not use units with less-than-nominal **4-inch (100-mm)** horizontal face dimensions at corners or jambs.
- D. Stopping and Resuming Work: Stop work by stepping back units in each course from those in course below; do not tooth. When resuming work, clean masonry surfaces that are to receive mortar, remove loose masonry units and mortar, and wet brick if required before laying fresh masonry.
- E. Built-in Work: As construction progresses, build in items specified in this and other Sections. Fill in solidly with masonry around built-in items.
- F. Fill space between steel frames and masonry solidly with mortar unless otherwise indicated.
- G. Where built-in items are to be embedded in cores of hollow masonry units, place a layer of metal lath, wire mesh, or plastic mesh in the joint below, and rod mortar or grout into core.

- H. Fill cores in hollow CMUs with grout **24 inches (600 mm)** under bearing plates, beams, lintels, posts, and similar items unless otherwise indicated.
- I. Build nonload-bearing interior partitions full height of story to underside of solid floor or roof structure above unless otherwise indicated.
 - 1. Install compressible filler in joint between top of partition and underside of structure above.

5.5 MORTAR BEDDING AND JOINTING

- A. Lay hollow CMUs as follows:
 - 1. Bed face shells in mortar and make head joints of depth equal to bed joints.
 - 2. Bed webs in mortar in all courses of piers, columns, and pilasters.
 - 3. Bed webs in mortar in grouted masonry, including starting course on footings.
 - 4. Fully bed entire units, including areas under cells, at starting course on footings where cells are not grouted.
- B. Lay solid CMUs with completely filled bed and head joints; butter ends with sufficient mortar to fill head joints and shove into place. Do not deeply furrow bed joints or slush head joints.
- C. Set cast-stone trim units in full bed of mortar with full vertical joints. Fill dowel, anchor, and similar holes.
 - 1. Clean soiled surfaces with fiber brush and soap powder and rinse thoroughly with clear water.
 - 2. Wet joint surfaces thoroughly before applying mortar.
 - 3. Rake out mortar joints for pointing with sealant.
- D. Rake out mortar joints at pre-faced CMUs to a uniform depth of **1/4 inch (6 mm)** and point with epoxy mortar to comply with epoxy-mortar manufacturer's written instructions.
- E. Tool exposed joints slightly concave when thumbprint hard, using a jointer larger than joint thickness unless otherwise indicated.
- F. Cut joints flush for masonry walls to receive plaster or other direct-applied finishes (other than paint) unless otherwise indicated.
- G. Cut joints flush where indicated to receive waterproofing unless otherwise indicated.

5.6 MASONRY-JOINT REINFORCEMENT

- A. General: Install entire length of longitudinal side rods in mortar with a minimum cover of **5/8 inch (16 mm)** on exterior side of walls, **1/2 inch (13 mm)** elsewhere. Lap reinforcement per requirements as indicated on Drawings.
- B. Interrupt joint reinforcement at control and expansion joints unless otherwise indicated.

5.7 ANCHORING MASONRY TO STRUCTURAL STEEL AND CONCRETE

- A. Anchor masonry to structural steel and concrete, where masonry abuts or faces structural steel or concrete, to comply with the following:
 - 1. Provide an open space not less than **1/2 inch (13 mm)** wide between masonry and structural steel or concrete unless otherwise indicated. Keep open space free of mortar and other rigid materials.
 - 2. Anchor masonry with anchors embedded in masonry joints and attached to structure.
 - 3. Space anchors as indicated.

5.8 CONTROL AND EXPANSION JOINTS

- A. General: Install control- and expansion-joint materials in unit masonry as masonry progresses. Do not allow materials to span control and expansion joints without provision to allow for in-plane wall or partition movement.
- B. Form control joints in concrete masonry using one of the following methods:
 - 1. Fit bond-breaker strips into hollow contour in ends of CMUs on one side of control joint. Fill resultant core with grout, and rake out joints in exposed faces for application of sealant.
 - 2. Install preformed control-joint gaskets designed to fit standard sash block.
 - 3. Install interlocking units designed for control joints. Install bond-breaker strips at joint. Keep head joints free and clear of mortar, or rake out joint for application of sealant.
 - 4. Install temporary foam-plastic filler in head joints, and remove filler when unit masonry is complete for application of sealant.

5.9 LINTELS

- A. Provide masonry lintels where shown and where openings of more than **12 inches (305 mm)** for brick-size units and **24 inches (610 mm)** for block-size units are shown without structural steel or other supporting lintels.

5.10 FLASHING

- A. General: Install embedded flashing at ledges and other obstructions to downward flow of water in wall where indicated.
- B. Install flashing as follows unless otherwise indicated:
 - 1. Prepare masonry surfaces so they are smooth and free from projections that could puncture flashing. Where flashing is within mortar joint, place through-wall flashing on sloping bed of mortar and cover with mortar. Before covering with mortar, seal penetrations in flashing with adhesive, sealant, or tape.
 - 2. At lintels, extend flashing a minimum of **6 inches (150 mm)** into masonry at each end. At heads and sills, extend flashing **6 inches (150 mm)** at ends and turn up not less than **2 inches (50 mm)** to form end dams.
 - 3. Interlock end joints of ribbed sheet metal flashing by overlapping ribs not less than **1-1/2 inches (38 mm)** or as recommended by flashing manufacturer, and seal lap with

elastomeric sealant complying with requirements in Section 079200 "Joint Sealants" for application indicated.

4. Install metal drip edges and sealant stops with ribbed sheet metal flashing by interlocking hemmed edges to form hooked seam. Seal seam with elastomeric sealant complying with requirements in Section 079200 "Joint Sealants" for application indicated.
- C. Install single-wythe CMU flashing system in bed joints of CMU walls where indicated to comply with manufacturer's written instructions. Install CMU cell pans with upturned edges located below face shells and webs of CMUs above and with weep spouts aligned with face of wall. Install CMU web covers so that they cover upturned edges of CMU cell pans at CMU webs and extend from face shell to face shell.
- D. Install reglets and nailers for flashing and other related construction where they are shown to be built into masonry.

5.11 REINFORCED UNIT MASONRY INSTALLATION

- A. Temporary Formwork and Shores: Construct formwork and shores as needed to support reinforced masonry elements during construction.
1. Construct formwork to provide shape, line, and dimensions of completed masonry as indicated. Make forms sufficiently tight to prevent leakage of mortar and grout. Brace, tie, and support forms to maintain position and shape during construction and curing of reinforced masonry.
 2. Do not remove forms and shores until reinforced masonry members have hardened sufficiently to carry their own weight and other loads that may be placed on them during construction.
- B. Placing Reinforcement: Comply with requirements in TMS 602/ACI 530.1/ASCE 6.
- C. Grouting: Do not place grout until entire height of masonry to be grouted has attained enough strength to resist grout pressure.
1. Comply with requirements in TMS 602/ACI 530.1/ASCE 6 for cleanouts and for grout placement, including minimum grout space and maximum pour height.
 2. Limit height of vertical grout pours to not more than **48 inches (1220 mm)**.

5.12 FIELD QUALITY CONTROL

- A. Testing and Inspecting: Owner will engage special inspectors to perform tests and inspections and prepare reports. Allow inspectors access to scaffolding and work areas as needed to perform tests and inspections. Retesting of materials that fail to comply with specified requirements shall be done at Contractor's expense.
- B. Inspections: Special inspections according to Level B in TMS 402/ACI 530/ASCE 5.
1. Begin masonry construction only after inspectors have verified proportions of site-prepared mortar.
 2. Place grout only after inspectors have verified compliance of grout spaces and of grades, sizes, and locations of reinforcement.
 3. Place grout only after inspectors have verified proportions of site-prepared grout.

- C. Testing Prior to Construction: One set of tests.
- D. Testing Frequency: One set of tests for each 5000 sq. ft. (464 sq. m) of wall area or portion thereof.
- E. Concrete Masonry Unit Test: For each type of unit provided, according to ASTM C 140 for compressive strength.
- F. Mortar Aggregate Ratio Test (Proportion Specification): For each mix provided, according to ASTM C 780.
- G. Mortar Test (Property Specification): For each mix provided, according to ASTM C 780. Test mortar for compressive strength.
- H. Grout Test (Compressive Strength): For each mix provided, according to ASTM C 1019.
- I. Prism Test: For each type of construction provided, according to ASTM C 1314 at 7 days and at 28 days.

5.13 PARGING

- A. Parge exterior faces of below-grade masonry walls, where indicated, in two uniform coats to a total thickness of 3/4 inch (19 mm). Dampen wall before applying first coat, and scarify first coat to ensure full bond to subsequent coat.
- B. Use a steel-trowel finish to produce a smooth, flat, dense surface with a maximum surface variation of 1/8 inch per foot (3 mm per 300 mm). Form a wash at top of parging and a cove at bottom.
- C. Damp-cure parging for at least 24 hours and protect parging until cured.

5.14 REPAIRING, POINTING, AND CLEANING

- A. Remove and replace masonry units that are loose, chipped, broken, stained, or otherwise damaged or that do not match adjoining units. Install new units to match adjoining units; install in fresh mortar, pointed to eliminate evidence of replacement.
- B. Pointing: During the tooling of joints, enlarge voids and holes, except weep holes, and completely fill with mortar. Point up joints, including corners, openings, and adjacent construction, to provide a neat, uniform appearance. Prepare joints for sealant application, where indicated.
- C. In-Progress Cleaning: Clean unit masonry as work progresses by dry brushing to remove mortar fins and smears before tooling joints.
- D. Final Cleaning: After mortar is thoroughly set and cured, clean exposed masonry as follows:
 1. Remove large mortar particles by hand with wooden paddles and nonmetallic scrape hoes or chisels.

2. Test cleaning methods on sample wall panel; leave one-half of panel uncleaned for comparison purposes. Obtain Architect's approval of sample cleaning before proceeding with cleaning of masonry.
3. Clean concrete masonry by applicable cleaning methods indicated in NCMA TEK 8-4A.

5.15 MASONRY WASTE DISPOSAL

- A. Salvageable Materials: Unless otherwise indicated, excess masonry materials are Contractor's property. At completion of unit masonry work, remove from Project site.
- B. Masonry Waste Recycling: Return broken CMUs not used as fill to manufacturer for recycling.
- C. Excess Masonry Waste: Remove excess clean masonry waste that cannot be used as fill, as described above or recycled, and other masonry waste, and legally dispose of off Owner's property.

END OF SECTION 042200

SECTION 051200
STRUCTURAL STEEL FRAMING

PART 6 - GENERAL

6.1 RELATED DOCUMENTS

- A. Drawings and general provisions of the Contract - Standard Specifications for Public Works Construction 'The GREENBOOK' and City Supplement 'The WHITEBOOK', including Supplemental Supplementary Provisions (SSPs), apply to this Section.

6.2 SUMMARY

A. Section Includes:

1. Structural steel.
2. Prefabricated building columns.
3. Field-installed shear connectors.
4. Grout.

B. Related Requirements:

1. Section 055000 "Metal Fabrications" for steel lintels and shelf angles not attached to structural-steel frame, miscellaneous steel fabrications, and, other steel items not defined as structural steel.
2. Section 099600 "High-Performance Coatings" for surface-preparation and priming requirements.

6.3 DEFINITIONS

- A. Structural Steel: Elements of the structural frame indicated on Drawings and as described in AISC 303, "Code of Standard Practice for Steel Buildings and Bridges."
- B. Seismic-Load-Resisting System: Elements of structural-steel frame designated as "SLRS" or along grid lines designated as "SLRS" on Drawings, including columns, beams, and braces and their connections.
- C. Heavy Sections: Rolled and built-up sections as follows:
1. Shapes included in ASTM A 6/A 6M with flanges thicker than **1-1/2 inches (38 mm)**.
 2. Welded built-up members with plates thicker than **2 inches (50 mm)**.
 3. Column base plates thicker than **2 inches (50 mm)**.
- D. Protected Zone: Structural members or portions of structural members indicated as "Protected Zone" on Drawings. Connections of structural and nonstructural elements to protected zones are limited.
- E. Demand Critical Welds: Those welds, the failure of which would result in significant degradation of the strength and stiffness of the Seismic-Load-Resisting System and which are indicated as "Demand Critical" or "Seismic Critical" on Drawings.

6.4 COORDINATION

- A. Coordinate selection of shop primers with topcoats to be applied over them. Comply with paint and coating manufacturers' written recommendations to ensure that shop primers and topcoats are compatible with one another.
- B. Coordinate installation of anchorage items to be embedded in or attached to other construction without delaying the Work. Provide setting diagrams, sheet metal templates, instructions, and directions for installation.

6.5 PREINSTALLATION MEETINGS

- A. Preinstallation Conference: Conduct conference at Project site.

6.6 ACTION SUBMITTALS

- A. Product Data: For each type of product.
- B. Shop Drawings: Show fabrication of structural-steel components.
 - 1. Include details of cuts, connections, splices, camber, holes, and other pertinent data.
 - 2. Include embedment Drawings.
 - 3. Indicate welds by standard AWS symbols, distinguishing between shop and field welds, and show size, length, and type of each weld. Show backing bars that are to be removed and supplemental fillet welds where backing bars are to remain.
 - 4. Indicate type, size, and length of bolts, distinguishing between shop and field bolts. Identify pretensioned and slip-critical, high-strength bolted connections.
 - 5. Identify members and connections of the Seismic-Load-Resisting System.
 - 6. Indicate locations and dimensions of protected zones.
 - 7. Identify demand critical welds.
- C. Welding Procedure Specifications (WPSs) and Procedure Qualification Records (PQRs): Provide according to AWS D1.1/D1.1M, "Structural Welding Code - Steel," for each welded joint whether prequalified or qualified by testing, including the following:
 - 1. Power source (constant current or constant voltage).
 - 2. Electrode manufacturer and trade name, for demand critical welds.

6.7 INFORMATIONAL SUBMITTALS

- A. Qualification Data: For Installer, fabricator, shop-painting applicators, testing agency.
- B. Welding certificates.
- C. Paint Compatibility Certificates: From manufacturers of topcoats applied over shop primers, certifying that shop primers are compatible with topcoats.
- D. Mill test reports for structural steel, including chemical and physical properties.
- E. Product Test Reports: For the following:

1. Bolts, nuts, and washers including mechanical properties and chemical analysis.
 2. Direct-tension indicators.
 3. Tension-control, high-strength, bolt-nut-washer assemblies.
 4. Shear stud connectors.
 5. Shop primers.
 6. Nonshrink grout.
- F. Survey of existing conditions.
- G. Source quality-control reports.
- H. Field quality-control and special inspection reports.

6.8 QUALITY ASSURANCE

- A. Fabricator Qualifications: A qualified fabricator that participates in the AISC Quality Certification Program and is designated an AISC-Certified Plant, Category STD.
- B. Installer Qualifications: A qualified installer who participates in the AISC Quality Certification Program and is designated an AISC-Certified Erector, Category CSE.
- C. Shop-Painting Applicators: Qualified according to AISC's Sophisticated Paint Endorsement P2 or to SSPC-QP 3, "Standard Procedure for Evaluating Qualifications of Shop Painting Applicators."
- D. Welding Qualifications: Qualify procedures and personnel according to AWS D1.1/D1.1M, "Structural Welding Code - Steel."
1. Welders and welding operators performing work on bottom-flange, demand-critical welds shall pass the supplemental welder qualification testing, as required by AWS D1.8/D1.8M. FCAW-S and FCAW-G shall be considered separate processes for welding personnel qualification.
- E. Comply with applicable provisions of the following specifications and documents:
1. AISC 303.
 2. AISC 341 and AISC 341s1.
 3. AISC 360.
 4. RCSC's "Specification for Structural Joints Using ASTM A 325 or A 490 Bolts."

6.9 DELIVERY, STORAGE, AND HANDLING

- A. Store materials to permit easy access for inspection and identification. Keep steel members off ground and spaced by using pallets, dunnage, or other supports and spacers. Protect steel members and packaged materials from corrosion and deterioration.
1. Do not store materials on structure in a manner that might cause distortion, damage, or overload to members or supporting structures. Repair or replace damaged materials or structures as directed.
- B. Store fasteners in a protected place in sealed containers with manufacturer's labels intact.

1. Fasteners may be repackaged provided Owner's testing and inspecting agency observes repackaging and seals containers.
2. Clean and relubricate bolts and nuts that become dry or rusty before use.
3. Comply with manufacturers' written recommendations for cleaning and lubricating ASTM F 1852 fasteners and for retesting fasteners after lubrication.

PART 7 - PRODUCTS

7.1 STRUCTURAL-STEEL MATERIALS

- A. W-Shapes: ASTM A 992/A 992M.
- B. Channels, Angles, M , S-Shapes: ASTM A 36/A 36M.
- C. Plate and Bar: ASTM A 36/A 36M.
- D. Cold-Formed Hollow Structural Sections: ASTM A 500/A 500M, Grade B, structural tubing.
- E. Steel Pipe: ASTM A 53/A 53M, Type E or Type S, Grade B.
 1. Weight Class: As indicated.
 2. Finish: Galvanized.
- F. Steel Castings: ASTM A 216/A 216M, Grade WCB with supplementary requirement S11.
- G. Steel Forgings: ASTM A 668/A 668M.
- H. Welding Electrodes: Comply with AWS requirements.

7.2 BOLTS, CONNECTORS, AND ANCHORS

- A. Unheaded Anchor Rods: ASTM F 1554, Grade 36.
 1. Configuration: As indicated.
 2. Nuts: **ASTM A 563** (**ASTM A 563M**) hex carbon steel.
 3. Plate Washers: ASTM A 36/A 36M carbon steel.
 4. Washers: **ASTM F 436** (**ASTM F 436M**), Type 1, hardened carbon steel.
 5. Finish: Hot-dip zinc coating, ASTM A 153/A 153M, Class C.
- B. Headed Anchor Rods: ASTM F 1554, Grade 36, straight.
 1. Nuts: **ASTM A 563** (**ASTM A 563M**) hex carbon steel.
 2. Plate Washers: ASTM A 36/A 36M carbon steel.
 3. Washers: **ASTM F 436** (**ASTM F 436M**), Type 1, hardened carbon steel.
 4. Finish: Hot-dip zinc coating, ASTM A 153/A 153M, Class C.
- C. Threaded Rods: ASTM A 36/A 36M.
 1. Nuts: **ASTM A 563** (**ASTM A 563M**) hex carbon steel.
 2. Washers: ASTM A 36/A 36M carbon steel.
 3. Finish: Hot-dip zinc coating, ASTM A 153/A 153M, Class C.

- D. Eye Bolts and Nuts: Made from cold-finished carbon steel bars, ASTM A 108, Grade 1030.
- E. Sleeve Nuts: Made from cold-finished carbon steel bars, ASTM A 108, Grade 1018.

7.3 PRIMER

- A. Primer: SSPC-Paint 25 BCS, Type II, zinc oxide, alkyd, linseed oil primer.
- B. Galvanizing Repair Paint: ASTM A 780/A 780M.

7.4 GROUT

- A. Nonmetallic, Shrinkage-Resistant Grout: ASTM C 1107/C 1107M, factory-packaged, nonmetallic aggregate grout, noncorrosive and nonstaining, mixed with water to consistency suitable for application and a 30-minute working time.

7.5 FABRICATION

- A. Structural Steel: Fabricate and assemble in shop to greatest extent possible. Fabricate according to AISC 303, "Code of Standard Practice for Steel Buildings and Bridges," and to AISC 360.
 - 1. Camber structural-steel members where indicated.
 - 2. Fabricate beams with rolling camber up.
 - 3. Identify high-strength structural steel according to ASTM A 6/A 6M and maintain markings until structural steel has been erected.
 - 4. Mark and match-mark materials for field assembly.
 - 5. Complete structural-steel assemblies, including welding of units, before starting shop-priming operations.
- B. Thermal Cutting: Perform thermal cutting by machine to greatest extent possible.
 - 1. Plane thermally cut edges to be welded to comply with requirements in AWS D1.1/D1.1M.
- C. Bolt Holes: Cut, drill, or punch standard bolt holes perpendicular to metal surfaces.
- D. Finishing: Accurately finish ends of columns and other members transmitting bearing loads.
- E. Holes: Provide holes required for securing other work to structural steel and for other work to pass through steel members.
 - 1. Cut, drill, or punch holes perpendicular to steel surfaces. Do not thermally cut bolt holes or enlarge holes by burning.
 - 2. Baseplate Holes: Cut, drill, mechanically thermal cut, or punch holes perpendicular to steel surfaces.
 - 3. Weld threaded nuts to framing and other specialty items indicated to receive other work.

7.6 SHOP CONNECTIONS

- A. Weld Connections: Comply with AWS D1.1/D1.1M for tolerances, appearances, welding procedure specifications, weld quality, and methods used in correcting welding work.

7.7 SHOP PRIMING

- A. Shop prime steel surfaces except the following:
 1. Surfaces embedded in concrete or mortar. Extend priming of partially embedded members to a depth of **2 inches (50 mm)**.
 2. Surfaces to be field welded.
 3. Surfaces of high-strength bolted, slip-critical connections.
 4. Surfaces to receive sprayed fire-resistive materials (applied fireproofing).
- B. Surface Preparation: Clean surfaces to be painted. Remove loose rust and mill scale and spatter, slag, or flux deposits. Prepare surfaces according to the following specifications and standards:
 1. SSPC-SP 6/NACE No. 3, "Commercial Blast Cleaning."
- C. Priming: Immediately after surface preparation, apply primer according to manufacturer's written instructions and at rate recommended by SSPC to provide a minimum dry film thickness of **1.5 mils (0.038 mm)**. Use priming methods that result in full coverage of joints, corners, edges, and exposed surfaces.
 1. Stripe paint corners, crevices, bolts, welds, and sharp edges.
 2. Apply two coats of shop paint to surfaces that are inaccessible after assembly or erection. Change color of second coat to distinguish it from first.

7.8 GALVANIZING

- A. Hot-Dip Galvanized Finish: Apply zinc coating by the hot-dip process to structural steel according to ASTM A 123/A 123M.
 1. Fill vent and drain holes that are exposed in the finished Work unless they function as weep holes, by plugging with zinc solder and filing off smooth.

7.9 SOURCE QUALITY CONTROL

- A. Testing Agency: Engage a qualified testing agency to perform shop tests and inspections.
 1. Provide testing agency with access to places where structural-steel work is being fabricated or produced to perform tests and inspections.
- B. Welded Connections: Visually inspect shop-welded connections according to AWS D1.1/D1.1M and the following inspection procedures, at testing agency's option:
 1. Liquid Penetrant Inspection: ASTM E 165.
 2. Magnetic Particle Inspection: ASTM E 709; performed on root pass and on finished weld. Cracks or zones of incomplete fusion or penetration are not accepted.
 3. Ultrasonic Inspection: ASTM E 164.

4. Radiographic Inspection: ASTM E 94.
- C. Prepare test and inspection reports.

PART 8 - EXECUTION

8.1 EXAMINATION

- A. Verify, with certified steel erector present, elevations of concrete- and masonry-bearing surfaces and locations of anchor rods, bearing plates, and other embedments for compliance with requirements.
1. Prepare a certified survey of existing conditions. Include bearing surfaces, anchor rods, bearing plates, and other embedments showing dimensions, locations, angles, and elevations.
- B. Proceed with installation only after unsatisfactory conditions have been corrected.

8.2 PREPARATION

- A. Provide temporary shores, guys, braces, and other supports during erection to keep structural steel secure, plumb, and in alignment against temporary construction loads and loads equal in intensity to design loads. Remove temporary supports when permanent structural steel, connections, and bracing are in place unless otherwise indicated.

8.3 ERECTION

- A. Set structural steel accurately in locations and to elevations indicated and according to AISC 303 and AISC 360.
- B. Baseplates Bearing Plates and Leveling Plates: Clean concrete- and masonry-bearing surfaces of bond-reducing materials, and roughen surfaces prior to setting plates. Clean bottom surface of plates.
1. Set plates for structural members on wedges, shims, or setting nuts as required.
 2. Weld plate washers to top of baseplate.
 3. Snug-tighten anchor rods after supported members have been positioned and plumbed. Do not remove wedges or shims but, if protruding, cut off flush with edge of plate before packing with grout.
 4. Promptly pack grout solidly between bearing surfaces and plates so no voids remain. Neatly finish exposed surfaces; protect grout and allow to cure. Comply with manufacturer's written installation instructions for shrinkage-resistant grouts.
- C. Maintain erection tolerances of structural steel within AISC 303, "Code of Standard Practice for Steel Buildings and Bridges."
- D. Align and adjust various members that form part of complete frame or structure before permanently fastening. Before assembly, clean bearing surfaces and other surfaces that are in permanent contact with members. Perform necessary adjustments to compensate for discrepancies in elevations and alignment.

1. Level and plumb individual members of structure.
- E. Splice members only where indicated.
- F. Do not use thermal cutting during erection.
- G. Do not enlarge unfair holes in members by burning or using drift pins. Ream holes that must be enlarged to admit bolts.
- H. Shear Connectors: Prepare steel surfaces as recommended by manufacturer of shear connectors. Use automatic end welding of headed-stud shear connectors according to AWS D1.1/D1.1M and manufacturer's written instructions.

8.4 FIELD CONNECTIONS

- A. Weld Connections: Comply with AWS D1.1/D1.1M for tolerances, appearances, welding procedure specifications, weld quality, and methods used in correcting welding work.
1. Comply with AISC 303 and AISC 360 for bearing, alignment, adequacy of temporary connections, and removal of paint on surfaces adjacent to field welds.
 2. Assemble and weld built-up sections by methods that maintain true alignment of axes without exceeding tolerances in AISC 303, "Code of Standard Practice for Steel Buildings and Bridges," for mill material.

8.5 PREFABRICATED BUILDING COLUMNS

- A. Install prefabricated building columns to comply with AISC 360, manufacturer's written recommendations, and requirements of testing and inspecting agency that apply to the fire-resistance rating indicated.

8.6 FIELD QUALITY CONTROL

- A. Special Inspections: Engage a qualified special inspector to perform the following special inspections:
1. Verify structural-steel materials and inspect steel frame joint details.
 2. Verify weld materials and inspect welds.
 3. Verify connection materials and inspect high-strength bolted connections.
- B. Testing Agency: Engage a qualified testing agency to perform tests and inspections.

8.7 REPAIRS AND PROTECTION

- A. Galvanized Surfaces: Clean areas where galvanizing is damaged or missing and repair galvanizing to comply with ASTM A 780/A 780M.
- B. Touchup Painting: Immediately after erection, clean exposed areas where primer is damaged or missing and paint with the same material as used for shop painting to comply with SSPC-PA 1 for touching up shop-painted surfaces.

1. Clean and prepare surfaces by SSPC-SP 2 hand-tool cleaning or SSPC-SP 3 power-tool cleaning.

END OF SECTION 051200

SECTION 051213

ARCHITECTURALLY EXPOSED STRUCTURAL STEEL FRAMING

1.1 RELATED DOCUMENTS

A. Drawings and general provisions of the Contract - Standard Specifications for Public Works Construction 'The GREENBOOK' and City Supplement 'The WHITEBOOK', latest editions, including Supplemental Supplementary Provisions (SSPs), apply to this Section.

1.2 SUMMARY

A. Section includes architecturally exposed structural-steel (AESS).

1. Requirements in Section 051200 "Structural Steel Framing" also apply to AESS.

B. Related Requirements:

1. Section 051200 "Structural Steel Framing" for additional requirements applicable to AESS.
2. Section 055000 "Metal Fabrications" for steel lintels and shelf angles not attached to structural-steel frame, miscellaneous steel fabrications, and, other metal items not defined as structural steel.

1.3 DEFINITIONS

A. AESS: Structural steel designated as "architecturally exposed structural steel" or "AESS" in the Contract Documents.

1.4 COORDINATION

A. Coordinate selection of shop primers with topcoats to be applied over them. Comply with paint and coating manufacturers' written recommendations to ensure that shop primers and topcoats are compatible with one another.

1.5 PREINSTALLATION MEETINGS

A. Preinstallation Conference: Conduct conference at Project site.

1.6 ACTION SUBMITTALS

A. Shop Drawings: Show fabrication of AESS components. Shop Drawings for structural steel may be used for AESS provided items of AESS are specifically identified and requirements below are met for AESS.

1. Include details of cuts, connections, splices, camber, holes, and other pertinent data.
2. Include embedment Drawings.
3. Indicate welds by standard AWS symbols, distinguishing between shop and field welds, and show size, length, and type of each weld. Show backing bars that are to be removed and supplemental fillet welds where backing bars are to remain. Indicate grinding, finish, and profile of welds.
4. Indicate type, size, and length of bolts, distinguishing between shop and field bolts. Identify pretensioned and slip-critical, high-strength bolted connections. Indicate orientation of bolt heads.

5. Indicate exposed surfaces and edges and surface preparation being used.
6. Indicate special tolerances and erection requirements.

B. Samples: Submit Samples of AESS to set quality standards for exposed welds.

1. Two steel plates, 3/8 by 8 by 4 inches (9.5 by 200 by 100 mm), with long edges joined by a groove weld and with weld ground smooth.
2. Steel plate, 3/8 by 8 by 8 inches (9.5 by 200 by 200 mm), with one end of a short length of rectangular steel tube, 4 by 6 by 3/8 inches (100 by 150 by 9.5 mm), welded to plate with a continuous fillet weld and with weld ground smooth and blended.
3. Round steel tube or pipe, minimum 8 inches (200 mm) in diameter, with end of another round steel tube or pipe, approximately 4 inches (100 mm) in diameter, welded to its side at a 45-degree angle with a continuous fillet weld and with weld ground smooth and blended.

1.7 INFORMATIONAL SUBMITTALS

A. Qualification Data: For fabricator.

B. Paint Compatibility Certificates: From manufacturers of topcoats applied over shop primers, certifying that shop primers are compatible with topcoats.

1.8 QUALITY ASSURANCE

A. Fabricator Qualifications: A qualified fabricator that participates in the AISC Quality Certification Program and is designated an AISC-Certified Plant, Category STD, or is accredited by the IAS Fabricator Inspection Program for Structural Steel (AC 172).

B. Shop-Painting Applicators: Qualified according to AISC's Sophisticated Paint Endorsement P1 or SSPC-QP 3, "Standard Procedure for Evaluating Qualifications of Shop Painting Applicators."

1.9 DELIVERY, STORAGE, AND HANDLING

A. Use special care in handling to prevent twisting, warping, nicking, and other damage. Store materials to permit easy access for inspection and identification. Keep steel members off ground and spaced by using pallets, dunnage, or other supports and spacers. Protect steel members and packaged materials from corrosion and deterioration.

1. Do not store materials on structure in a manner that might cause distortion, damage, or overload to members or supporting structures. Repair or replace damaged materials or structures as directed.

1.10 FIELD CONDITIONS

A. Field Measurements: Where AESS is indicated to fit against other construction, verify actual dimensions by field measurements before fabrication.

PART 2 - PRODUCTS

2.1 BOLTS, CONNECTORS, AND ANCHORS

A. Tension-Control, High-Strength Bolt-Nut-Washer Assemblies: ASTM F 1852, Type 1,

round-head assemblies, consisting of steel structural bolts with splined ends, heavy-hex carbon-steel nuts, and hardened carbon-steel washers.

1. Finish: Mechanically deposited zinc coating.

B. Corrosion-Resisting (Weathering Steel), Tension-Control, High-Strength Bolt-Nut-Washer Assemblies: ASTM F 1852, Type 3, round-head assemblies, consisting of steel structural bolts with splined ends, heavy-hex carbon-steel nuts, and hardened carbonsteel washers.

2.2 FILLER

A. Filler: Polyester filler intended for use in repairing dents in automobile bodies.

2.3 PRIMER

A. Primer: SSPC-Paint 25 BCS, Type II, zinc oxide, alkyd, linseed oil primer.

B. Etching Cleaner for Galvanized Metal: MPI#25.

C. Galvanizing Repair Paint: ASTM A 780/A 780M.

D. Shop Primer for Galvanized Steel: MPI#134, water-based galvanized metal primer.

2.4 FABRICATION

A. Shop fabricate and assemble AESS to the maximum extent possible. Locate field joints at concealed locations if possible. Detail assemblies to minimize handling and to expedite erection.

B. In addition to special care used to handle and fabricate AESS, comply with the following:

1. Fabricate with exposed surfaces smooth, square, and free of surface blemishes including pitting, rust, scale, and roughness.
 2. Grind sheared, punched, and flame-cut edges of AESS to remove burrs and provide smooth surfaces and edges.
 3. Fabricate AESS with exposed surfaces free of mill marks, including rolled trade names and stamped or raised identification.
 4. Fabricate AESS with exposed surfaces free of seams to maximum extent possible.
 5. Remove blemishes by filling or grinding or by welding and grinding, before cleaning, treating, and shop priming.
 6. Fabricate with piece marks fully hidden in the completed structure or made with media that permits full removal after erection.
 7. Fabricate AESS to the tolerances specified in AISC 303 for steel that is designated AESS.
 8. Fabricate AESS to the tolerances specified in AISC 303 for steel that is not designated AESS.
 9. Seal-weld open ends of hollow structural sections with 3/8-inch (9.5-mm) closure plates for AESS.
- C. Curved Members: Fabricate indicated members to curved shape by rolling to final shape in fabrication shop.

1. Distortion of webs, stems, outstanding flanges, and legs of angles shall not be visible from a distance of 20 feet (6 m) under any lighting conditions.

2. Tolerances for walls of hollow steel sections after rolling shall be approximately 1/2 inch (13 mm).

D. Coping, Blocking, and Joint Gaps: Maintain uniform gaps of 1/8 inch (3.2 mm) with a tolerance of 1/32 inch (0.8 mm) for AESS.

E. Bolt Holes: Cut, drill, or punch standard bolt holes perpendicular to metal surfaces.

F. Holes: Provide holes required for securing other work to structural steel and for other work to pass through steel members.

1. Cut, drill, or punch holes perpendicular to steel surfaces. Do not thermally cut bolt holes or enlarge holes by burning.

2. Baseplate Holes: Cut, drill, mechanically thermal cut, or punch holes perpendicular to steel surfaces.

3. Weld threaded nuts to framing and other specialty items indicated to receive other work.

2.5 SHOP CONNECTIONS

A. Weld Connections: Comply with AWS D1.1/D1.1M for tolerances, appearances, welding procedure specifications, weld quality, and methods used in correcting welding work, and comply with the following:

1. Assemble and weld built-up sections by methods that will maintain true alignment of axes without exceeding specified tolerances.

2. Use weld sizes, fabrication sequence, and equipment for AESS that limit distortions to allowable tolerances.

3. Provide continuous, sealed welds at angle to gusset-plate connections and similar locations where AESS is exposed to weather.

4. Provide continuous welds of uniform size and profile where AESS is welded.

5. Grind butt and groove welds flush to adjacent surfaces within tolerance of plus 1/16 inch, minus zero inch (plus 1.5 mm, minus zero mm) for AESS.

6. Remove backing bars or runoff tabs; back-gouge and grind steel smooth AESS.

7. At locations where welding on the far side of an exposed connection of AESS occurs, grind distortions and marking of the steel to a smooth profile aligned with adjacent material.

8. Make fillet welds for AESS oversize and grind to uniform profile with smooth face and transition.

2.6 GALVANIZING

A. Hot-Dip Galvanized Finish: Apply zinc coating by the hot-dip process to structural steel according to ASTM A 123/A 123M.

1. Do not quench or apply post-galvanizing treatments that might interfere with paint adhesion.

2. Fill vent and drain holes that are exposed in the finished Work, unless indicated to remain as weep holes, by plugging with zinc solder and filing off smooth.

2.7 SHOP PRIMING

A. Shop prime steel surfaces except the following:

1. Surfaces embedded in concrete or mortar. Extend priming of partially embedded members to a depth of 2 inches (50 mm).
 2. Surfaces to be field welded.
 3. Surfaces to be high-strength bolted with slip-critical connections.
 4. Surfaces to receive sprayed fire-resistive materials.
- B. Surface Preparation for Nongalvanized Steel: Clean surfaces to be painted. Remove loose rust and mill scale and spatter, slag, or flux deposits. Prepare surfaces according to the following specifications and standards:
1. SSPC-SP 11, "Power Tool Cleaning to Bare Metal."
- C. Preparing Galvanized Steel for Shop Priming: After galvanizing, thoroughly clean steel of grease, dirt, oil, flux, and other foreign matter, and treat with etching cleaner.
- D. Priming: Immediately after surface preparation, apply primer according to manufacturer's written instructions and at rate recommended by SSPC to provide a minimum dry film thickness of 1.5 mils (0.038 mm). Use priming methods that result in full coverage of joints, corners, edges, and exposed surfaces.
1. Stripe paint corners, crevices, bolts, welds, and sharp edges.
 2. Apply two coats of shop paint to surfaces that are inaccessible after assembly or erection. Change color of second coat to distinguish it from first.

PART 3 - EXECUTION

3.1 EXAMINATION

- A. Verify, with steel erector present, elevations of concrete- and masonry-bearing surfaces and locations of anchor rods, bearing plates, and other embedments for compliance with requirements.
1. Prepare a certified survey of bearing surfaces, anchor rods, bearing plates, and other embedments showing dimensions, locations, angles, and elevations.
- B. Examine AESS for twists, kinks, warping, gouges, and other imperfections before erecting.
- C. Proceed with installation only after unsatisfactory conditions have been corrected.

3.2 PREPARATION

- A. Provide temporary shores, guys, braces, and other supports during erection to keep AESS secure, plumb, and in alignment against temporary construction loads and loads equal in intensity to design loads. Remove temporary supports when permanent structural steel, connections, and bracing are in place unless otherwise indicated.
1. If possible, locate welded tabs for attaching temporary bracing and safety cabling where they will be concealed from view in the completed Work.

3.3 ERECTION

A. Set AESS accurately in locations and to elevations indicated and according to AISC 303 and AISC 360.

1. Erect AESS to the tolerances specified in AISC 303 for steel that is designated AESS.
 2. Erect AESS to the tolerances specified in AISC 303 for steel that is not designated AESS.
- B. Do not use thermal cutting during erection.

3.4 FIELD CONNECTIONS

A. Weld Connections: Comply with requirements in "Weld Connections" Paragraph in "Shop Connections" Article.

1. Remove backing bars or runoff tabs; back-gouge and grind steel smooth for AESS.
2. Remove erection bolts in AESS, fill holes, and grind smooth.
3. Fill weld access holes in AESS and grind smooth.

3.5 FIELD QUALITY CONTROL

A. Testing Agency: Engage a qualified independent testing and inspecting agency to inspect AESS as specified in Section 051200 "Structural Steel Framing." The testing agency is not responsible for enforcing requirements relating to aesthetic effect.

B. Architect will observe AESS in place to determine acceptability relating to aesthetic effect.

3.6 REPAIRS AND PROTECTION

A. Remove welded tabs that were used for attaching temporary bracing and safety cabling and that are exposed to view in the completed Work. Grind steel smooth.

B. Galvanized Surfaces: Clean field welds, bolted connections, and abraded areas and repair galvanizing to comply with ASTM A 780/A 780M.

B. Touchup Painting: Immediately after erection, clean field welds, bolted connections, and abraded areas of shop paint, and paint exposed areas with the same material as used for shop painting to comply with SSPC-PA 1 for touching up shop-painted surfaces.

1. Clean and prepare surfaces by SSPC-SP 3 power-tool cleaning.

END OF SECTION 051213

SECTION 055000

METAL FABRICATIONS

PART 9 - GENERAL

9.1 RELATED DOCUMENTS

- A. Drawings and general provisions of the Contract - Standard Specifications for Public Works Construction 'The GREENBOOK' and City Supplement 'The WHITEBOOK', including Supplemental Supplementary Provisions (SSPs), apply to this Section.

9.2 SUMMARY

- A. Section Includes:

1. Steel framing and supports for countertops.
2. Steel framing and supports for mechanical and electrical equipment.
3. Steel framing and supports for applications where framing and supports are not specified in other Sections.
4. Metal downspout boots.
5. Loose bearing and leveling plates for applications where they are not specified in other Sections.

- B. Products furnished, but not installed, under this Section include the following:

1. Loose steel lintels.
2. Anchor bolts, steel pipe sleeves, slotted-channel inserts, and wedge-type inserts indicated to be cast into concrete or built into unit masonry.
3. Steel weld plates and angles for casting into concrete for applications where they are not specified in other Sections.

- C. Related Requirements:

1. Section 033000 "Cast-in-Place Concrete" for installing anchor bolts, steel pipe sleeves, slotted-channel inserts, wedge-type inserts, and other items cast into concrete.
2. Section 042200 "Unit Masonry" for installing loose lintels, anchor bolts, and other items built into unit masonry.
3. Section 051200 "Structural Steel Framing."

9.3 COORDINATION

- A. Coordinate selection of shop primers with topcoats to be applied over them. Comply with paint and coating manufacturers' written recommendations to ensure that shop primers and topcoats are compatible with one another.

- B. Coordinate installation of metal fabrications that are anchored to or that receive other work. Furnish setting drawings, templates, and directions for installing anchorages, including sleeves, concrete inserts, anchor bolts, and items with integral anchors, that are to be embedded in concrete or masonry. Deliver such items to Project site in time for installation.

9.4 ACTION SUBMITTALS

- A. Product Data: For the following:
 - 1. Paint products.
 - 2. Grout.
- B. Shop Drawings: Show fabrication and installation details. Include plans, elevations, sections, and details of metal fabrications and their connections. Show anchorage and accessory items. Provide Shop Drawings for the following:
 - 1. Steel framing and supports for countertops.
 - 2. Steel framing and supports for mechanical and electrical equipment.
 - 3. Steel framing and supports for applications where framing and supports are not specified in other Sections.
 - 4. Metal downspout boots.

9.5 INFORMATIONAL SUBMITTALS

- A. Qualification Data: For professional engineer.
- B. Welding certificates.
- C. Paint Compatibility Certificates: From manufacturers of topcoats applied over shop primers, certifying that shop primers are compatible with topcoats.
- D. Research/Evaluation Reports: For post-installed anchors, from ICC-ES.

9.6 QUALITY ASSURANCE

- A. Welding Qualifications: Qualify procedures and personnel according to AWS D1.1/D1.1M, "Structural Welding Code - Steel."

9.7 FIELD CONDITIONS

- A. Field Measurements: Verify actual locations of walls and other construction contiguous with metal fabrications by field measurements before fabrication.

9.8 REGULATORY REQUIREMENTS

- A. Railings and Handrails – CBC 11B-505:
 - 1. Top of gripping surfaces of handrails shall be 34 inches minimum and 38 inches maximum vertically above walking surfaces, stair nosings, and ramp surfaces. Handrails shall be at a consistent height above such surfaces.
 - 2. Clearance between handrail gripping surfaces and adjacent surfaces shall be 1-1/2 inches minimum. Handrail may be located in a recess if the recess is 3 inches maximum deep and 18 inches minimum clear above top of handrail.
 - 3. Handrail gripping surfaces shall be continuous along their length and shall not be obstructed along their tops or sides. The bottoms of handrail gripping surfaces shall not be obstructed for more than 20% of their length. Where provided, horizontal projections shall occur 1-1/2" minimum below the bottom of handrail gripping surfaces.

4. Handrail gripping surfaces with a circular cross section shall have an outside diameter of 1-1/4 inches minimum and 2 inches maximum.
5. Handrail gripping surfaces with a non-circular cross section shall have an outside dimension of 4 inches minimum and 6-1/4 inches maximum, and a cross-sectional dimension of 2-1/4 inches maximum.
6. Handrail gripping surfaces and any surfaces adjacent to them shall be free of sharp or abrasive elements and shall have rounding edges.
7. Handrails shall not rotate within their fittings.
8. Handrail gripping surfaces shall extend beyond and in the same direction of stair flights and ramp runs in accordance with CBC Section 11B-505.10. Such extensions are not required for continuous handrails at the inside turn of switchback or dogleg stairs and ramps.
9. The orientation of at least one handrail shall be in the direction of the stair run, perpendicular to the direction of the stair nosing, and shall not reduce the minimum required width of the stair. CBC Section 11B-505.2.1
10. A 2 inch minimum high curb or barrier shall be provided to prevent the passage of a 4 inch diameter sphere rolling off the edges on a ramp or landing surface. Such a curb or barrier shall be continuous and uninterrupted along the length of a ramp. CBC Section 11B-405.9.2

PART 10 - PRODUCTS

10.1 PERFORMANCE REQUIREMENTS

- A. Thermal Movements: Allow for thermal movements from ambient and surface temperature changes acting on exterior metal fabrications by preventing buckling, opening of joints, overstressing of components, failure of connections, and other detrimental effects.
 1. Temperature Change: 120 deg F (67 deg C), ambient; 180 deg F (100 deg C), material surfaces.

10.2 METALS

- A. Metal Surfaces, General: Provide materials with smooth, flat surfaces unless otherwise indicated. For metal fabrications exposed to view in the completed Work, provide materials without seam marks, roller marks, rolled trade names, or blemishes.
- B. Steel Plates, Shapes, and Bars: ASTM A 36/A 36M.
- C. Stainless-Steel Sheet, Strip, and Plate: ASTM A 240/A 240M or ASTM A 666, Type 304.
- D. Stainless-Steel Bars and Shapes: ASTM A 276, Type 316L.
- E. Steel Tubing: ASTM A 500/A 500M, cold-formed steel tubing.
- F. Steel Pipe: ASTM A 53/A 53M, Standard Weight (Schedule 40) unless otherwise indicated.
- G. Slotted Channel Framing: Cold-formed metal box channels (struts) complying with MFMA-4.
 1. Size of Channels: As indicated.

2. Material: Galvanized steel, ASTM A 653/A 653M, structural steel, **Grade 33 (Grade 230)**, with **G90 (Z275)** coating; **0.079-inch (2-mm)** nominal thickness.
- H. Cast Iron: Either gray iron, ASTM A 48/A 48M, or malleable iron, ASTM A 47/A 47M, unless otherwise indicated.
- I. Aluminum Plate and Sheet: **ASTM B 209 (ASTM B 209M)**, Alloy 6061-T6.
- J. Aluminum Extrusions: **ASTM B 221 (ASTM B 221M)**, Alloy 6063-T6.
- K. Aluminum-Alloy Rolled Tread Plate: ASTM B 632/B 632M, Alloy 6061-T6.
- L. Aluminum Castings: ASTM B 26/B 26M, Alloy 443.0-F.
- M. Nickel Silver Extrusions: ASTM B 151/B 151M, Alloy UNS No. C74500.
- N. Nickel Silver Castings: ASTM B 584, Alloy UNS No. C97600 (20 percent leaded nickel bronze).

10.3 FASTENERS

- A. General: Unless otherwise indicated, provide Type 304 stainless-steel fasteners for exterior use and zinc-plated fasteners with coating complying with ASTM B 633 or **ASTM F 1941 (ASTM F 1941M)**, Class Fe/Zn 5, at exterior walls. Select fasteners for type, grade, and class required.
 1. Provide stainless-steel fasteners for fastening aluminum.
 2. Provide stainless-steel fasteners for fastening stainless steel.
 3. Provide stainless-steel fasteners for fastening nickel silver.
- B. Steel Bolts and Nuts: Regular hexagon-head bolts, **ASTM A 307, Grade A (ASTM F 568M, Property Class 4.6)**; with hex nuts, **ASTM A 563 (ASTM A 563M)**; and, where indicated, flat washers.
- C. Stainless-Steel Bolts and Nuts: Regular hexagon-head annealed stainless-steel bolts, **ASTM F 593 (ASTM F 738M)**; with hex nuts, **ASTM F 594 (ASTM F 836M)**; and, where indicated, flat washers; Alloy Group **1 (A1)**.
- D. Anchor Bolts: ASTM F 1554, Grade 36, of dimensions indicated; with nuts, **ASTM A 563 (ASTM A 563M)**; and, where indicated, flat washers.
 1. Hot-dip galvanize or provide mechanically deposited, zinc coating where item being fastened is indicated to be galvanized.
- E. Anchors, General: Anchors capable of sustaining, without failure, a load equal to six times the load imposed when installed in unit masonry and four times the load imposed when installed in concrete, as determined by testing according to ASTM E 488/E 488M, conducted by a qualified independent testing agency.
- F. Cast-in-Place Anchors in Concrete: Either threaded type or wedge type unless otherwise indicated; galvanized ferrous castings, either ASTM A 47/A 47M malleable iron or ASTM A 27/A 27M cast steel. Provide bolts, washers, and shims as needed, all hot-dip galvanized per ASTM F 2329.

- G. Post-Installed Anchors: chemical anchors.
 - 1. Material for Exterior Locations and Where Stainless Steel Is Indicated: Alloy Group 1 (A1) stainless-steel bolts, ASTM F 593 (ASTM F 738M), and nuts, ASTM F 594 (ASTM F 836M).

10.4 MISCELLANEOUS MATERIALS

- A. Epoxy Zinc-Rich Primer: Complying with MPI#20 and compatible with topcoat.
- B. Shop Primer for Galvanized Steel: Primer formulated for exterior use over zinc-coated metal and compatible with finish paint systems indicated.
- C. Galvanizing Repair Paint: High-zinc-dust-content paint complying with SSPC-Paint 20 and compatible with paints specified to be used over it.
- D. Bituminous Paint: Cold-applied asphalt emulsion complying with ASTM D 1187/D 1187M.
- E. Nonshrink, Nonmetallic Grout: Factory-packaged, nonstaining, noncorrosive, nongaseous grout complying with ASTM C 1107/C 1107M. Provide grout specifically recommended by manufacturer for interior and exterior applications.

10.5 FABRICATION, GENERAL

- A. Shop Assembly: Preassemble items in the shop to greatest extent possible. Disassemble units only as necessary for shipping and handling limitations. Use connections that maintain structural value of joined pieces. Clearly mark units for reassembly and coordinated installation.
- B. Cut, drill, and punch metals cleanly and accurately. Remove burrs and ease edges to a radius of approximately 1/32 inch (1 mm) unless otherwise indicated. Remove sharp or rough areas on exposed surfaces.
- C. Form bent-metal corners to smallest radius possible without causing grain separation or otherwise impairing work.
- D. Form exposed work with accurate angles and surfaces and straight edges.
- E. Weld corners and seams continuously to comply with the following:
 - 1. Use materials and methods that minimize distortion and develop strength and corrosion resistance of base metals.
 - 2. Obtain fusion without undercut or overlap.
 - 3. Remove welding flux immediately.
 - 4. At exposed connections, finish exposed welds and surfaces smooth and blended so no roughness shows after finishing and contour of welded surface matches that of adjacent surface.
- F. Form exposed connections with hairline joints, flush and smooth, using concealed fasteners or welds where possible. Where exposed fasteners are required, use Phillips flat-head (countersunk) fasteners unless otherwise indicated. Locate joints where least conspicuous.

- G. Fabricate seams and other connections that are exposed to weather in a manner to exclude water. Provide weep holes where water may accumulate.
- H. Cut, reinforce, drill, and tap metal fabrications as indicated to receive finish hardware, screws, and similar items.
- I. Provide for anchorage of type indicated; coordinate with supporting structure. Space anchoring devices to secure metal fabrications rigidly in place and to support indicated loads.
- J. Where units are indicated to be cast into concrete or built into masonry, equip with integrally welded steel strap anchors, **1/8 by 1-1/2 inches (3.2 by 38 mm)**, with a minimum **6-inch (150-mm)** embedment and **2-inch (50-mm)** hook, not less than **8 inches (200 mm)** from ends and corners of units and **24 inches (600 mm)** o.c., unless otherwise indicated.

10.6 MISCELLANEOUS FRAMING AND SUPPORTS

- A. General: Provide steel framing and supports not specified in other Sections as needed to complete the Work.
- B. Fabricate units from steel shapes, plates, and bars of welded construction unless otherwise indicated. Fabricate to sizes, shapes, and profiles indicated and as necessary to receive adjacent construction.
 - 1. Fabricate units from slotted channel framing where indicated.
 - 2. Furnish inserts for units installed after concrete is placed.
- C. Galvanize miscellaneous framing and supports where indicated.
- D. Prime miscellaneous framing and supports with zinc-rich primer where indicated.

10.7 MISCELLANEOUS STEEL TRIM

- A. Unless otherwise indicated, fabricate units from steel shapes, plates, and bars of profiles shown with continuously welded joints and smooth exposed edges. Miter corners and use concealed field splices where possible.
- B. Provide cutouts, fittings, and anchorages as needed to coordinate assembly and installation with other work.
 - 1. Provide with integrally welded steel strap anchors for embedding in concrete or masonry construction.
- C. Galvanize and prime exterior miscellaneous steel trim.
- D. Prime exterior miscellaneous steel trim with zinc-rich primer.

10.8 METAL DOWNSPOUT BOOTS

- A. Provide downspout boots made from cast iron in heights indicated with inlets of size and shape to suit downspouts. Provide units with flanges and holes for countersunk anchor bolts.
 - 1. Outlet: Vertical, to discharge into pipe.
- B. Prime cast-iron downspout boots with zinc-rich primer.

10.9 LOOSE BEARING AND LEVELING PLATES

- A. Provide loose bearing and leveling plates for steel items bearing on masonry or concrete construction. Drill plates to receive anchor bolts and for grouting.
- B. Galvanize plates.
- C. Prime plates with zinc-rich primer.

10.10 LOOSE STEEL LINTELS

- A. Fabricate loose steel lintels from steel angles and shapes of size indicated for openings and recesses in masonry walls and partitions at locations indicated. Fabricate in single lengths for each opening unless otherwise indicated. Weld adjoining members together to form a single unit where indicated.
- B. Size loose lintels to provide bearing length at each side of openings equal to 1/12 of clear span, but not less than **8 inches (200 mm)** unless otherwise indicated.
- C. Galvanize and prime loose steel lintels located in exterior walls.
- D. Prime loose steel lintels located in exterior walls with zinc-rich primer.

10.11 STEEL WELD PLATES AND ANGLES

- A. Provide steel weld plates and angles not specified in other Sections, for items supported from concrete construction as needed to complete the Work. Provide each unit with no fewer than two integrally welded steel strap anchors for embedding in concrete.

10.12 FINISHES, GENERAL

- A. Finish metal fabrications after assembly.
- B. Finish exposed surfaces to remove tool and die marks and stretch lines, and to blend into surrounding surface.

10.13 STEEL AND IRON FINISHES

- A. Galvanizing: Hot-dip galvanize items as indicated to comply with ASTM A 153/A 153M for steel and iron hardware and with ASTM A 123/A 123M for other steel and iron products.
 - 1. Do not quench or apply post galvanizing treatments that might interfere with paint adhesion.
- B. Preparation for Shop Priming Galvanized Items: After galvanizing, thoroughly clean railings of grease, dirt, oil, flux, and other foreign matter, and treat with metallic phosphate process.
- C. Shop prime iron and steel items not indicated to be galvanized unless they are to be embedded in concrete, sprayed-on fireproofing, or masonry, or unless otherwise indicated.
 - 1. Shop prime with zinc-rich primer.
- D. Preparation for Shop Priming: Prepare surfaces to comply with requirements indicated below:
 - 1. Exterior Items: SSPC-SP 6/NACE No. 3, "Commercial Blast Cleaning."
 - 2. Items Indicated to Receive Zinc-Rich Primer: SSPC-SP 6/NACE No. 3, "Commercial Blast Cleaning."
 - 3. Items Indicated to Receive Primers Specified in Section 099600 "High-Performance Coatings": SSPC-SP 6/NACE No. 3, "Commercial Blast Cleaning."
 - 4. Other Items: SSPC-SP 3, "Power Tool Cleaning."
- E. Shop Priming: Apply shop primer to comply with SSPC-PA 1, "Paint Application Specification No. 1: Shop, Field, and Maintenance Painting of Steel," for shop painting.
 - 1. Stripe paint corners, crevices, bolts, welds, and sharp edges.

10.14 ALUMINUM FINISHES

- A. As-Fabricated Finish: AA-M12.
- B. Clear Anodic Finish: AAMA 611, Class I, AA-M12C22A41.

PART 11 - EXECUTION

11.1 INSTALLATION, GENERAL

- A. Cutting, Fitting, and Placement: Perform cutting, drilling, and fitting required for installing metal fabrications. Set metal fabrications accurately in location, alignment, and elevation; with edges and surfaces level, plumb, true, and free of rack; and measured from established lines and levels.
- B. Fit exposed connections accurately together to form hairline joints. Weld connections that are not to be left as exposed joints but cannot be shop welded because of shipping size limitations. Do not weld, cut, or abrade surfaces of exterior units that have been hot-dip galvanized after fabrication and are for bolted or screwed field connections.

- C. Field Welding: Comply with the following requirements:
 1. Use materials and methods that minimize distortion and develop strength and corrosion resistance of base metals.
 2. Obtain fusion without undercut or overlap.
 3. Remove welding flux immediately.
 4. At exposed connections, finish exposed welds and surfaces smooth and blended so no roughness shows after finishing and contour of welded surface matches that of adjacent surface.
- D. Fastening to In-Place Construction: Provide anchorage devices and fasteners where metal fabrications are required to be fastened to in-place construction. Provide threaded fasteners for use with concrete and masonry inserts, toggle bolts, through bolts, lag screws, wood screws, and other connectors.
- E. Provide temporary bracing or anchors in formwork for items that are to be built into concrete, masonry, or similar construction.
- F. Corrosion Protection: Coat concealed surfaces of aluminum that come into contact with grout, concrete, masonry, wood, or dissimilar metals with the following:
 1. Cast Aluminum: Heavy coat of bituminous paint.
 2. Extruded Aluminum: Two coats of clear lacquer.

11.2 INSTALLING MISCELLANEOUS FRAMING AND SUPPORTS

- A. General: Install framing and supports to comply with requirements of items being supported, including manufacturers' written instructions and requirements indicated on Shop Drawings.
- B. Support steel girders on solid grouted masonry, concrete, or steel pipe columns. Secure girders with anchor bolts embedded in grouted masonry or concrete or with bolts through top plates of pipe columns.
 1. Where grout space under bearing plates is indicated for girders supported on concrete or masonry, install as specified in "Installing Bearing and Leveling Plates" Article.
- C. Install pipe columns on concrete footings with grouted baseplates. Position and grout column baseplates as specified in "Installing Bearing and Leveling Plates" Article.
 1. Grout baseplates of columns supporting steel girders after girders are installed and leveled.

11.3 INSTALLING BEARING AND LEVELING PLATES

- A. Clean concrete and masonry bearing surfaces of bond-reducing materials and roughen to improve bond to surfaces. Clean bottom surface of plates.
- B. Set bearing and leveling plates on wedges, shims, or leveling nuts. After bearing members have been positioned and plumbed, tighten anchor bolts. Do not remove wedges or shims but, if protruding, cut off flush with edge of bearing plate before packing with nonshrink

grout. Pack grout solidly between bearing surfaces and plates to ensure that no voids remain.

11.4 ADJUSTING AND CLEANING

- A. Touchup Painting: Immediately after erection, clean field welds, bolted connections, and abraded areas. Paint uncoated and abraded areas with the same material as used for shop painting to comply with SSPC-PA 1 for touching up shop-painted surfaces.
 - 1. Apply by brush or spray to provide a minimum **2.0-mil (0.05-mm)** dry film thickness.
- B. Touchup Painting: Cleaning and touchup painting of field welds, bolted connections, and abraded areas of shop paint are specified in Section 099600 "High-Performance Coating."
- C. Galvanized Surfaces: Clean field welds, bolted connections, and abraded areas and repair galvanizing to comply with ASTM A 780/A 780M.

END OF SECTION 055000

SECTION 055313

BAR GRATINGS

PART 12 - GENERAL

12.1 RELATED DOCUMENTS

- A. Drawings and general provisions of the Contract - Standard Specifications for Public Works Construction 'The GREENBOOK' and City Supplement 'The WHITEBOOK', latest editions, including Supplemental Supplementary Provisions (SSPs), apply to this Section.

12.2 SUMMARY

- A. Section includes metal bar gratings.
- B. Related Requirements:
 - 1. Section 051200 "Structural Steel Framing" for structural-steel framing system components.

12.3 COORDINATION

- A. Coordinate selection of shop primers with topcoats to be applied over them. Comply with paint and coating manufacturers' written instructions to ensure that shop primers and topcoats are compatible with one another.
- B. Coordinate installation of anchorages for gratings, grating frames, and supports. Furnish setting drawings, templates, and directions for installing anchorages, including sleeves, concrete inserts, anchor bolts, and items with integral anchors, that are to be embedded in concrete or masonry. Deliver such items to Project site in time for installation.

12.4 ACTION SUBMITTALS

- A. Product Data: For the following:
 - 1. Clips and anchorage devices for gratings.
- B. Shop Drawings: Include plans, sections, details, and attachments to other work.

12.5 INFORMATIONAL SUBMITTALS

- A. Mill Certificates: Signed by manufacturers of stainless-steel certifying that products furnished comply with requirements.
- B. Welding certificates.

12.6 QUALITY ASSURANCE

- A. Welding Qualifications: Qualify procedures and personnel according to the following:
 1. AWS D1.1/D1.1M, "Structural Welding Code - Steel."
 2. AWS D1.3/D1.3M, "Structural Welding Code - Sheet Steel."

12.7 FIELD CONDITIONS

- A. Field Measurements: Verify actual locations of walls and other construction contiguous with gratings by field measurements before fabrication.

PART 13 - PRODUCTS

13.1 PERFORMANCE REQUIREMENTS

- A. Seismic Performance: Gratings shall withstand the effects of earthquake motions determined according to ASCE/SEI 7.
 1. Component Importance Factor: 1.5.

13.2 METAL BAR GRATINGS

- A. Metal Bar Grating Standards: Comply with NAAMM MBG 531, "Metal Bar Grating Manual."
- B. Pressure-Locked Steel Grating: Fabricated by swaging crossbars between bearing bars.
 1. Bearing Bar Spacing: 15/16 inch (24 mm) o.c.
 2. Bearing Bar Depth: 1-1/2 inches (38 mm).
 3. Bearing Bar Thickness: 1/8 inch (3.2 mm).
 4. Crossbar Spacing: 4 inches (102 mm) o.c.
 5. Integrated Anchorage: Weld Lugs, same material and thickness as bearing bar, fit between bearing bars, size hole to coordinate with fasteners.
 6. Steel Finish: Hot-dip galvanized with a coating weight of not less than 1.8 oz./sq. ft. (550 g/sq. m) of coated surface.

13.3 FERROUS METALS

- A. Steel Plates, Shapes, and Bars: ASTM A36/A36M.
- B. Steel Bars for Bar Gratings: ASTM A36/A36M or steel strip, ASTM A1011/A1011M or ASTM A1018/A1018M.
- C. Wire Rod for Bar Grating Crossbars: ASTM A510 (ASTM A510M).

13.4 FASTENERS

- A. General: Unless otherwise indicated, provide zinc-plated fasteners with coating complying with ASTM B633 or **ASTM F1941 (ASTM F1941M)**, Class Fe/Zn 5, at exterior walls. Select fasteners for type, grade, and class required.
- B. Steel Bolts and Nuts: Regular hexagon-head bolts, **ASTM A307, Grade A (ASTM F568M, Property Class 4.6)**; with hex nuts, **ASTM A563 (ASTM A563M)**, and, where indicated, flat washers.
- C. Post-Installed Anchors: chemical anchors capable of sustaining, without failure, a load equal to six times the load imposed when installed in unit masonry and four times the load imposed when installed in concrete, as determined by testing according to ASTM E 488/E 488M, conducted by a qualified independent testing agency.
 - 1. Material for Exterior Locations and Where Stainless Steel Is Indicated: Alloy Group **1 (A1)** stainless-steel bolts, **ASTM F 593 (ASTM F 738M)**, and nuts, **ASTM F 594 (ASTM F 836M)**.

13.5 MISCELLANEOUS MATERIALS

- A. Galvanizing Repair Paint: High-zinc-dust-content paint complying with SSPC-Paint 20 and compatible with paints specified to be used over it.

13.6 FABRICATION

- A. Shop Assembly: Fabricate grating sections in shop to greatest extent possible to minimize field splicing and assembly. Disassemble units only as necessary for shipping and handling limitations. Use connections that maintain structural value of joined pieces. Clearly mark units for reassembly and coordinated installation.
- B. Cut, drill, and punch material cleanly and accurately. Remove burrs and ease edges to a radius of approximately **1/32 inch (1 mm)** unless otherwise indicated. Remove sharp or rough areas on exposed surfaces.
- C. Form from materials of size, thickness, and shapes indicated, but not less than that needed to support indicated loads.
- D. Fit exposed connections accurately together to form hairline joints.
- E. Welding: Comply with AWS recommendations and the following:
 - 1. Use materials and methods that minimize distortion and develop strength and corrosion resistance of base metals.
 - 2. Obtain fusion without undercut or overlap.
 - 3. Remove welding flux immediately.
- F. Provide for anchorage of type indicated; coordinate with supporting structure. Fabricate and space the anchoring devices to secure gratings, frames, and supports rigidly in place and to support indicated loads.

- G. Grating Sections: Fabricate with banding bars attached by welding to entire perimeter of each section. Include anchors and fasteners of type indicated or, if not indicated, as recommended by manufacturer for attaching to supports.
 - 1. Provide no fewer than four weld lugs for each grating section, with each lug shop welded to two bearing bars.
 - 2. Furnish threaded bolts with nuts and washers for securing grating to supports.
- H. Fabricate cutouts in grating sections for penetrations indicated. Arrange cutouts to permit grating removal without disturbing items penetrating gratings.
 - 1. Edge-band openings in grating that interrupt four or more bearing bars with bars of same size and material as bearing bars.
- I. Do not notch bearing bars at supports to maintain elevation.

13.7 STEEL FINISHES

- A. Finish gratings, frames, and supports after assembly.
- B. Galvanizing: Hot-dip galvanize items as indicated to comply with ASTM A153/A153M for steel and iron hardware and with ASTM A123/A123M for other steel and iron products.
 - 1. Do not quench or apply post galvanizing treatments that might interfere with paint adhesion

PART 14 - EXECUTION

14.1 INSTALLATION, GENERAL

- A. Fastening to In-Place Construction: Provide anchorage devices and fasteners where necessary for securing gratings to in-place construction. Include threaded fasteners for concrete and masonry inserts, through-bolts, lag bolts, and other connectors.
- B. Cutting, Fitting, and Placement: Perform cutting, drilling, and fitting required for installing gratings. Set units accurately in location, alignment, and elevation; measured from established lines and levels and free of rack.
- C. Provide temporary bracing or anchors in formwork for items that are to be built into concrete or masonry.
- D. Fit exposed connections accurately together to form hairline joints.
 - 1. Weld connections that are not to be left as exposed joints but cannot be shop welded because of shipping size limitations. Do not weld, cut, or abrade the surfaces of exterior units that have been hot-dip galvanized after fabrication and are for bolted or screwed field connections.
- E. Field Welding: Comply with AWS recommendations and the following:
 - 1. Use materials and methods that minimize distortion and develop strength and corrosion resistance of base metals.

2. Obtain fusion without undercut or overlap.
3. Remove welding flux immediately.

14.2 INSTALLING METAL BAR GRATINGS

- A. General: Install gratings to comply with recommendations of referenced metal bar grating standards that apply to grating types and bar sizes indicated, including installation clearances and standard anchoring details.
- B. Attach removable units to supporting members with type and size of clips and fasteners indicated or, if not indicated, as recommended by grating manufacturer for type of installation conditions shown.
- C. Attach nonremovable units to supporting members by welding where both materials are same; otherwise, fasten by bolting as indicated above.

14.3 ADJUSTING AND CLEANING

- A. Galvanized Surfaces: Clean field welds, bolted connections, and abraded areas and repair galvanizing to comply with ASTM A780/A780M.

END OF SECTION 055313

SECTION 061000
ROUGH CARPENTRY

PART 15 - GENERAL

15.1 RELATED DOCUMENTS

- A. Drawings and general provisions of the Contract - Standard Specifications for Public Works Construction 'The GREENBOOK' and City Supplement 'The WHITEBOOK', latest editions, including Supplemental Supplementary Provisions (SSPs), apply to this Section.

15.2 SUMMARY

- A. Section Includes:

- 1. Framing with dimension lumber.
- 2. Framing with engineered wood products.
- 3. Wood blocking and nailers.
- 4. Wood furring and grounds.
- 5. Wood sleepers.
- 6. Plywood backing panels.

- B. Related Requirements:

- 1. Section 061600 "Sheathing" for sheathing, subflooring, and underlayment.

15.3 DEFINITIONS

- A. Boards or Strips: Lumber of less than **2 inches nominal (38 mm actual)** size in least dimension.
- B. Dimension Lumber: Lumber of **2 inches nominal (38 mm actual)** size or greater but less than **5 inches nominal (114 mm actual)** size in least dimension.
- C. Exposed Framing: Framing not concealed by other construction.
- D. OSB: Oriented strand board.
- E. Timber: Lumber of **5 inches nominal (114 mm actual)** size or greater in least dimension.

15.4 ACTION SUBMITTALS

- A. Product Data: For each type of process and factory-fabricated product. Indicate component materials and dimensions and include construction and application details.
 - 1. Include data for wood-preservative treatment from chemical treatment manufacturer and certification by treating plant that treated materials comply with requirements. Indicate type of preservative used and net amount of preservative retained.

2. Include data for fire-retardant treatment from chemical treatment manufacturer and certification by treating plant that treated materials comply with requirements. Include physical properties of treated materials based on testing by a qualified independent testing agency.
3. For fire-retardant treatments, include physical properties of treated lumber both before and after exposure to elevated temperatures, based on testing by a qualified independent testing agency according to ASTM D 5664.
4. For products receiving a waterborne treatment, include statement that moisture content of treated materials was reduced to levels specified before shipment to Project site.

15.5 INFORMATIONAL SUBMITTALS

- A. Material Certificates: For dimension lumber specified to comply with minimum allowable unit stresses. Indicate species and grade selected for each use and design values approved by the ALSC Board of Review.
- B. Evaluation Reports: For the following, from ICC-ES:
 1. Wood-preservative-treated wood.
 2. Fire-retardant-treated wood.
 3. Engineered wood products.
 4. Shear panels.
 5. Power-driven fasteners.
 6. Post-installed anchors.
 7. Metal framing anchors.

15.6 QUALITY ASSURANCE

- A. Testing Agency Qualifications: For testing agency providing classification marking for fire-retardant treated material, an inspection agency acceptable to authorities having jurisdiction that periodically performs inspections to verify that the material bearing the classification marking is representative of the material tested.

15.7 DELIVERY, STORAGE, AND HANDLING

- A. Stack wood products flat with spacers beneath and between each bundle to provide air circulation. Protect wood products from weather by covering with waterproof sheeting, securely anchored. Provide for air circulation around stacks and under coverings.

PART 16 - PRODUCTS

16.1 WOOD PRODUCTS, GENERAL

- A. Lumber: DOC PS 20 and applicable rules of grading agencies indicated. If no grading agency is indicated, comply with the applicable rules of any rules-writing agency certified by the ALSC Board of Review. Grade lumber by an agency certified by the ALSC Board of Review to inspect and grade lumber under the rules indicated.

1. Factory mark each piece of lumber with grade stamp of grading agency.
 2. For exposed lumber indicated to receive a stained or natural finish, mark grade stamp on end or back of each piece.
 3. Dress lumber, S4S, unless otherwise indicated.
- B. Maximum Moisture Content of Lumber: 19 percent unless otherwise indicated.
- C. Engineered Wood Products: Acceptable to authorities having jurisdiction and for which current model code research or evaluation reports exist that show compliance with building code in effect for Project.
1. Allowable design stresses, as published by manufacturer, shall meet or exceed those indicated. Manufacturer's published values shall be determined from empirical data or by rational engineering analysis and demonstrated by comprehensive testing performed by a qualified independent testing agency.

16.2 WOOD-PRESERVATIVE-TREATED LUMBER

- A. Preservative Treatment by Pressure Process: AWPA U1; Use Category UC2 for interior construction not in contact with ground, Use Category UC3b for exterior construction not in contact with ground, and Use Category UC4a for items in contact with ground.
1. Preservative Chemicals: Acceptable to authorities having jurisdiction and containing no arsenic or chromium. Do not use inorganic boron (SBX) for sill plates.
 2. For exposed items indicated to receive a stained or natural finish, chemical formulations shall not require incising, contain colorants, bleed through, or otherwise adversely affect finishes.
- B. Kiln-dry lumber after treatment to a maximum moisture content of 19 percent. Do not use material that is warped or that does not comply with requirements for untreated material.
- C. Mark lumber with treatment quality mark of an inspection agency approved by the ALSC Board of Review.
1. For exposed lumber indicated to receive a stained or natural finish, mark end or back of each piece.
- D. Application: Treat all rough carpentry unless otherwise indicated.
1. Wood cants, nailers, curbs, equipment support bases, blocking, stripping, and similar members in connection with roofing, flashing, vapor barriers, and waterproofing.
 2. Wood sills, sleepers, blocking, furring, stripping, and similar concealed members in contact with masonry or concrete.
 3. Wood framing and furring attached directly to the interior of below-grade exterior masonry or concrete walls.
 4. Wood framing members that are less than **18 inches (460 mm)** above the ground in crawlspaces or unexcavated areas.
 5. Wood floor plates that are installed over concrete slabs-on-grade.

16.3 DIMENSION LUMBER FRAMING

- A. Joists, Rafters, and Other Framing Not Listed Above: Minimum grade as indicated on Drawings.
 - 1. Species:
 - a. Hem-fir (north); NLGA.
 - b. Southern pine; SPIB.
 - c. Douglas fir-larch; WCLIB or WWPA.
- B. Exposed Framing Indicated to Receive a Stained or Natural Finish: Hand-select material for uniformity of appearance and freedom from characteristics, on exposed surfaces and edges, that would impair finish appearance, including decay, honeycomb, knot-holes, shake, splits, torn grain, and wane.
 - 1. Species and Grade: As indicated above for load-bearing construction of same type.

16.4 ENGINEERED WOOD PRODUCTS

- A. Source Limitations: Obtain each type of engineered wood product from single source from a single manufacturer.
- B. Laminated-Veneer Lumber: Structural composite lumber made from wood veneers with grain primarily parallel to member lengths, evaluated and monitored according to ASTM D 5456 and manufactured with an exterior-type adhesive complying with ASTM D 2559.
 - 1. [Provide product as indicated on Drawings.](#)
 - 2. [Provide product in compliance with ICC ESR-1040.](#)
- C. I-joists: Specially constructed I-joists with flanges made from Laminated-Veneer Lumber with oriented strand board webs and waterproof structural adhesives.
 - 1. [Provide product as indicated on Drawings.](#)
 - 2. [Provide product in compliance with ICC ESR-1336.](#)

16.5 MISCELLANEOUS LUMBER

- A. General: Provide miscellaneous lumber indicated and lumber for support or attachment of other construction, including the following:
 - 1. Blocking.
 - 2. Nailers.
 - 3. Rooftop equipment bases and support curbs.
 - 4. Cants.
 - 5. Furring.
 - 6. Grounds.
 - 7. Utility shelving.
- B. Dimension Lumber Items: Minimum grade as indicated on Drawings. grade lumber of any of the following species:
 - 1. Hem-fir (north); NLGA.

2. Mixed southern pine or southern pine; SPIB.
 3. Spruce-pine-fir; NLGA.
 4. Hem-fir; WCLIB or WWPA.
 5. Spruce-pine-fir (south); NeLMA, WCLIB, or WWPA.
- C. Concealed Boards: 19 percent maximum moisture content and any of the following species and grades:
1. Mixed southern pine or southern pine; No. 2 grade; SPIB.
 2. Hem-fir or hem-fir (north); Construction or No. 2 Common grade; NLGA, WCLIB, or WWPA.
 3. Spruce-pine-fir (south) or spruce-pine-fir; Construction or No. 2 Common grade; NeLMA, NLGA, WCLIB, or WWPA.
- D. For blocking not used for attachment of other construction, Utility, Stud, or No. 3 grade lumber of any species may be used provided that it is cut and selected to eliminate defects that will interfere with its attachment and purpose.
- E. For blocking and nailers used for attachment of other construction, select and cut lumber to eliminate knots and other defects that will interfere with attachment of other work.
- F. For furring strips for installing plywood or hardboard paneling, select boards with no knots capable of producing bent-over nails and damage to paneling.

16.6 PLYWOOD BACKING PANELS

- A. Equipment Backing Panels: Plywood, DOC PS 1, Exterior, A-C, fire-retardant treated, in thickness indicated or, if not indicated, not less than **3/4-inch (19-mm)** nominal thickness.

16.7 FASTENERS

- A. General: Fasteners shall be of size and type indicated and shall comply with requirements specified in this article for material and manufacture.
1. Where rough carpentry is exposed to weather, in ground contact, pressure-preservative treated, or in area of high relative humidity, provide fasteners of Type 304 stainless steel.
- B. Nails, Brads, and Staples: ASTM F 1667.
- C. Power-Driven Fasteners: Fastener systems with an evaluation report acceptable to authorities having jurisdiction, based on ICC-ES AC70.
- D. Post-Installed Anchors: Fastener systems with an evaluation report acceptable to authorities having jurisdiction, based on ICC-ES AC01, ICC-ES AC58, ICC-ES AC193, or ICC-ES AC308 as appropriate for the substrate.
1. Material: Stainless steel with bolts and nuts complying with **ASTM F 593 and ASTM F 594, Alloy Group 1 or 2 (ASTM F 738M and ASTM F 836M, Grade A1 or A4)**.

16.8 METAL FRAMING ANCHORS

- A. Allowable design loads, as published by manufacturer, shall meet or exceed those indicated on Drawings. Manufacturer's published values shall be determined from empirical data or by rational engineering analysis and demonstrated by comprehensive testing performed by a qualified independent testing agency. Framing anchors shall be punched for fasteners adequate to withstand same loads as framing anchors.
- B. Stainless-Steel Sheet: ASTM A 666, Type 316.
 - 1. Use for exterior locations and where indicated.

16.9 MISCELLANEOUS MATERIALS

- A. Adhesives for Gluing to Concrete or Masonry: Formulation complying with ASTM D 3498 that is approved for use indicated by adhesive manufacturer.
- B. Water-Repellent Preservative: NWWDA-tested and -accepted formulation containing 3-iodo-2-propynyl butyl carbamate, combined with an insecticide containing chlorpyrifos as its active ingredient.

PART 17 - EXECUTION

17.1 INSTALLATION, GENERAL

- A. Framing Standard: Comply with AF&PA's WCD 1, "Details for Conventional Wood Frame Construction," unless otherwise indicated.
- B. Framing with Engineered Wood Products: Install engineered wood products to comply with manufacturer's written instructions.
- C. Set rough carpentry to required levels and lines, with members plumb, true to line, cut, and fitted. Fit rough carpentry accurately to other construction. Locate furring, nailers, blocking, grounds, and similar supports to comply with requirements for attaching other construction.
- D. Install plywood backing panels by fastening to studs; coordinate locations with utilities requiring backing panels. Install fire-retardant-treated plywood backing panels with classification marking of testing agency exposed to view.
- E. Install shear wall panels to comply with manufacturer's written instructions.
- F. Install metal framing anchors to comply with manufacturer's written instructions. Install fasteners through each fastener hole.
- G. Install sill sealer gasket to form continuous seal between sill plates and foundation walls.
- H. Do not splice structural members between supports unless otherwise indicated.
- I. Provide blocking and framing as indicated and as required to support facing materials, fixtures, specialty items, and trim.

1. Provide metal clips for fastening gypsum board or lath at corners and intersections where framing or blocking does not provide a surface for fastening edges of panels. Space clips not more than **16 inches (406 mm)** o.c.
- J. Provide fire blocking in furred spaces, stud spaces, and other concealed cavities as indicated and as follows:
1. Fire block furred spaces of walls, at each floor level, at ceiling, and at not more than **96 inches (2438 mm)** o.c. with solid wood blocking or noncombustible materials accurately fitted to close furred spaces.
 2. Fire block concealed spaces of wood-framed walls and partitions at each floor level, at ceiling line of top story, and at not more than **96 inches (2438 mm)** o.c. Where fire blocking is not inherent in framing system used, provide closely fitted solid wood blocks of same width as framing members and **2-inch nominal (38-mm actual)** thickness.
 3. Fire block concealed spaces between floor sleepers with same material as sleepers to limit concealed spaces to not more than **100 sq. ft. (9.3 sq. m)** and to solidly fill space below partitions.
- K. Sort and select lumber so that natural characteristics do not interfere with installation or with fastening other materials to lumber. Do not use materials with defects that interfere with function of member or pieces that are too small to use with minimum number of joints or optimum joint arrangement.
- L. Comply with AWPAC M4 for applying field treatment to cut surfaces of preservative-treated lumber.
1. Use inorganic boron for items that are continuously protected from liquid water.
 2. Use copper naphthenate for items not continuously protected from liquid water.
- M. Where wood-preservative-treated lumber is installed adjacent to metal decking, install continuous flexible flashing separator between wood and metal decking.
- N. Securely attach rough carpentry work to substrate by anchoring and fastening as indicated, complying with the following:
1. Table 2304.9.1, "Fastening Schedule," in California Building Code (CBC).
 2. ICC-ES evaluation report for fastener.
- O. Use steel common nails unless otherwise indicated. Select fasteners of size that will not fully penetrate members where opposite side will be exposed to view or will receive finish materials. Make tight connections between members. Install fasteners without splitting wood. Drive nails snug but do not countersink nail heads unless otherwise indicated.
- P. For exposed work, arrange fasteners in straight rows parallel with edges of members, with fasteners evenly spaced, and with adjacent rows staggered.
1. Comply with indicated fastener patterns where applicable. Before fastening, mark fastener locations, using a template made of sheet metal, plastic, or cardboard.
 2. Use common nails unless otherwise indicated. Drive nails snug but do not countersink nail heads.

17.2 WOOD BLOCKING, AND NAILER INSTALLATION

- A. Install where indicated and where required for attaching other work. Form to shapes indicated and cut as required for true line and level of attached work. Coordinate locations with other work involved.
- B. Attach items to substrates to support applied loading. Recess bolts and nuts flush with surfaces unless otherwise indicated.
- C. At I-joists, provide blocking as required by manufacturer and ICC ESR-1336.

17.3 WOOD FURRING INSTALLATION

- A. Install level and plumb with closure strips at edges and openings. Shim with wood as required for tolerance of finish work.

17.4 CEILING JOIST AND RAFTER FRAMING INSTALLATION

- A. Ceiling Joists: Install with crown edge up and complying with requirements specified above for floor joists. Face nail to ends of parallel rafters.
- B. Rafters: Notch to fit exterior wall plates and use metal framing anchors. Double rafters to form headers and trimmers at openings in roof framing, if any, and support with metal hangers. Where rafters abut at ridge, place directly opposite each other and nail to ridge member or use metal ridge hangers.
 - 1. At valleys, provide double-valley rafters of size indicated or, if not indicated, of same thickness as regular rafters and **2 inches (50 mm)** deeper. Bevel ends of jack rafters for full bearing against valley rafters.
 - 2. At hips, provide hip rafter of size indicated or, if not indicated, of same thickness as regular rafters and **2 inches (50 mm)** deeper. Bevel ends of jack rafters for full bearing against hip rafter.
- C. Provide collar beams (ties) as indicated or, if not indicated, provide **1-by-6-inch nominal- (19-by-140-mm actual-)** size boards between every third pair of rafters, but not more than **48 inches (1219 mm)** o.c. Locate below ridge member, at third point of rafter span. Cut ends to fit roof slope and nail to rafters.
- D. Provide special framing as indicated for eaves, overhangs, dormers, and similar conditions if any.
- E. Provide and install Laminated Veneer Lumber products in accordance with ICC ESR-1040.
- F. Provide and install special I-joist products in accordance with ICC ESR-1336.

17.5 PROTECTION

- A. Protect wood that has been treated with inorganic boron (SBX) from weather. If, despite protection, inorganic boron-treated wood becomes wet, apply EPA-registered borate treatment. Apply borate solution by spraying to comply with EPA-registered label.

- B. Protect rough carpentry from weather. If, despite protection, rough carpentry becomes wet enough that moisture content exceeds that specified, apply EPA-registered borate treatment. Apply borate solution by spraying to comply with EPA-registered label.

END OF SECTION 061000

SECTION 061600

SHEATHING

17.6 RELATED DOCUMENTS

- A. Drawings and general provisions of the Contract - Standard Specifications for Public Works Construction 'The GREENBOOK' and City Supplement 'The WHITEBOOK', latest editions, including Supplemental Supplementary Provisions (SSPs), apply to this Section.

17.7 SUMMARY

- A. Section Includes:
 - 1. Roof sheathing.
 - 2. Sheathing joint and penetration treatment.
- B. Related Requirements:
 - 1. Section 061000 "Rough Carpentry" for plywood backing panels.

17.8 PREINSTALLATION MEETINGS

- A. Preinstallation Conference: Conduct conference at Project site.

17.9 ACTION SUBMITTALS

- A. Product Data: For each type of process and factory-fabricated product. Indicate component materials and dimensions and include construction and application details.

17.10 INFORMATIONAL SUBMITTALS

- A. Qualification Data: For Installer, including list of ABAA-certified installers and supervisors employed by Installer, who work on Project.

17.11 DELIVERY, STORAGE, AND HANDLING

- A. Stack panels flat with spacers beneath and between each bundle to provide air circulation. Protect sheathing from weather by covering with waterproof sheeting, securely anchored. Provide for air circulation around stacks and under coverings.

PART 18 - PRODUCTS

18.1 WOOD PANEL PRODUCTS

- A. Thickness: As needed to comply with requirements specified, but not less than thickness indicated.

- B. Factory mark panels to indicate compliance with applicable standard.

18.2 ROOF SHEATHING

- A. Plywood Sheathing: DOC PS 1, Structural 1, Exposure 1 sheathing.
 - 1. Span Rating: Not less than 32/16.
 - 2. Nominal Thickness: Not less than 5/8 inch (16 mm).

18.3 FASTENERS

- A. General: Provide fasteners of size and type indicated that comply with requirements specified in this article for material and manufacture.
 - 1. For roof sheathing, provide fasteners with hot-dip zinc coating complying with ASTM A153/A153M, and of Type 304 or 316 stainless steel when in contact with pressure treated or fire treated wood.
- B. Power-Driven Fasteners: Fastener systems with an evaluation report acceptable to authorities having jurisdiction, based on ICC-ES AC70.
- C. Screws for Fastening Sheathing to Wood Framing: ASTM C1002.
- D. Screws for Fastening Wood Structural Panels to Cold-Formed Metal Framing: ASTM C954, except with wafer heads and reamer wings, length as recommended by screw manufacturer for material being fastened.

PART 19 - EXECUTION

19.1 INSTALLATION, GENERAL

- A. Do not use materials with defects that impair quality of sheathing or pieces that are too small to use with minimum number of joints or optimum joint arrangement. Arrange joints so that pieces do not span between fewer than three support members.
- B. Cut panels at penetrations, edges, and other obstructions of work; fit tightly against abutting construction unless otherwise indicated.
- C. Securely attach to substrate by fastening as indicated, complying with the following:
 - 1. Table 2304.9.1, "Fastening Schedule," in the CBC's California Building Code.
 - 2. ICC-ES evaluation report for fastener.
- D. Use common wire nails unless otherwise indicated. Select fasteners of size that will not fully penetrate members where opposite side will be exposed to view or will receive finish materials. Make tight connections. Install fasteners without splitting wood.
- E. Coordinate wall sheathing installation with flashing and joint-sealant installation so these materials are installed in sequence and manner that prevent exterior moisture from passing through completed assembly.

- F. Do not bridge building expansion joints; cut and space edges of panels to match spacing of structural support elements.
- G. Coordinate sheathing installation with installation of materials installed over sheathing so sheathing is not exposed to precipitation or left exposed at end of the workday when rain is forecast.

19.2 WOOD STRUCTURAL PANEL INSTALLATION

- A. General: Comply with applicable recommendations in APA Form No. E30, "Engineered Wood Construction Guide," for types of structural-use panels and applications indicated.
- B. Fastening Methods: Fasten panels as indicated below:
 - 1. Roof Sheathing:
 - a. Nail to wood framing.
 - b. Space panels **1/8 inch (3 mm)** apart at edges and ends.

END OF SECTION 061600

SECTION 061800

GLUED-LAMINATED CONSTRUCTION

PART 20 - GENERAL

20.1 RELATED DOCUMENTS

- A. Drawings and general provisions of the Contract - Standard Specifications for Public Works Construction 'The GREENBOOK' and City Supplement 'The WHITEBOOK', latest editions, including Supplemental Supplementary Provisions (SSPs), apply to this Section.

20.2 SUMMARY

- A. Section Includes:

- 1. Framing using structural glued-laminated timber.

- B. Related Requirements:

- 1. Section 061000 "Rough Carpentry" for dimension lumber items associated with structural glued-laminated timber.

20.3 DEFINITIONS

- A. Structural Glued-Laminated (Glulam) Timber: An engineered, stress-rated timber product assembled from selected and prepared wood laminations bonded together with adhesives and with the grain of the laminations approximately parallel longitudinally.

20.4 ACTION SUBMITTALS

- A. Product Data: For each type of product.

- 1. Include data on lumber, adhesives, fabrication, and protection.
- 2. For preservative-treated wood products. Include chemical treatment manufacturer's written instructions for handling, storing, installing, and finishing treated material.
- 3. For connectors. Include installation instructions.

- B. Shop Drawings:

- 1. Show layout of structural glued-laminated timber system and full dimensions of each member.
- 2. Indicate species and laminating combination.

20.5 INFORMATIONAL SUBMITTALS

- A. Certificates of Conformance: Issued by a qualified testing and inspecting agency indicating that structural glued-laminated timber complies with requirements in AITC A190.1.

- B. Material Certificates: For preservative-treated wood products, from manufacturer. Indicate type of preservative used and net amount of preservative retained.
- C. Research/Evaluation Reports: For structural glued-laminated timber and timber connectors, from ICC-ES.

20.6 QUALITY ASSURANCE

- A. Manufacturer Qualifications: An AITC- or APA-EWS-licensed firm.

20.7 DELIVERY, STORAGE, AND HANDLING

- A. General: Comply with provisions in AITC 111.
- B. Individually wrap members using plastic-coated paper covering with water-resistant seams.

PART 21 - PRODUCTS

21.1 PERFORMANCE REQUIREMENTS

- A. Structural Performance: Structural glued-laminated timber and connectors shall withstand the effects of structural loads shown on Drawings without exceeding allowable design working stresses listed in AITC 117 or determined according to ASTM D3737 and acceptable to authorities having jurisdiction.
- B. Seismic Performance: Structural glued-laminated timber and connectors shall withstand the effects of earthquake motions determined according to ASCE/SEI 7.

21.2 STRUCTURAL GLUED-LAMINATED TIMBER

- A. General: Provide structural glued-laminated timber that complies with AITC A190.1 and AITC 117 or research/evaluation reports acceptable to authorities having jurisdiction.
 - 1. Factory mark each piece of structural glued-laminated timber with AITC Quality Mark or APA-EWS trademark. Place mark on surfaces that are not exposed in the completed Work.
 - 2. Provide structural glued-laminated timber made from single species.
 - 3. Provide structural glued-laminated timber made from solid lumber laminations; do not use laminated veneer lumber.
 - 4. Provide structural glued-laminated timber made with wet-use adhesive complying with AITC A190.1.
- B. Species and Grades for Structural Glued-Laminated Timber: Port Orford cedar.
- C. Species and Grades for Beams:
 - 1. Species and Combination Symbol: Port Orford Cedar 22F-V/POC1.
- D. Appearance Grade: Architectural, complying with AITC 110.

1. For Architectural appearance grades, fill voids as required by AITC 110.

21.3 TIMBER CONNECTORS

- A. Manufacturers: Subject to compliance with requirements, provide products by the following:
 1. Simpson Strong-Tie Co., Inc.
 2. Approved equal.
- B. Fabricate beam seats from steel with **3/8-inch (9.5-mm)** bearing plates, **3/4-inch- (19-mm-)** diameter-by-**12-inch- (300-mm-)** long deformed bar anchors, and **0.239-inch (6-mm)** side plates.
- C. Fabricate beam hangers from steel with **0.179-inch (4.6-mm)** stirrups and **0.239-inch (6-mm)** top plates.
- D. Fabricate hinge connectors from steel with **0.179-inch (4.6-mm)** side plates and **1-inch (25-mm)** top and bottom plates, unless otherwise indicated on drawings.
- E. Fabricate strap ties from steel, **3 inches (75 mm)** wide by **0.239 inch (6 mm)** thick, unless otherwise indicated on Drawings.
- F. Fabricate tie rods from round steel bars with upset threads connected with forged-steel turnbuckles complying with ASTM A668/A668M.
- G. Provide bolts, **3/4 inch (19 mm)** unless otherwise indicated, complying with **ASTM A307, Grade A (ASTM F568M, Property Class 4.6)**; nuts complying with **ASTM A563 (ASTM A563M)**; and, where indicated, flat washers.
- H. Provide shear plates, **4 inches (102 mm)** in diameter, unless otherwise indicated, complying with ASTM D5933.
- I. Materials: Unless otherwise indicated, fabricate from the following materials:
 1. Structural-steel shapes, plates, and flat bars complying with ASTM A36/A36M.
 2. Round steel bars complying with ASTM A575, Grade M 1020.
 3. Hot-rolled steel sheet complying with ASTM A1011/A1011M, Structural Steel, Type SS, Grade 33.
 4. Stainless steel flat bars complying with ASTM A666, Type 304.
 5. Stainless steel bars and shapes complying with ASTM A276, Type 304.
 6. Stainless steel plate, sheet, and strip complying with ASTM A240/A240M or ASTM A666, Type 304.
- J. Hot-dip galvanize steel assemblies and fasteners after fabrication to comply with ASTM A123/A123M or ASTM A153/A153M.

21.4 MISCELLANEOUS MATERIALS

- A. End Sealer: Manufacturer's standard, transparent, colorless wood sealer that is effective in retarding the transmission of moisture at cross-grain cuts and is compatible with indicated finish.

- B. Penetrating Sealer: Manufacturer's standard, transparent, penetrating wood sealer that is compatible with indicated finish.

21.5 FABRICATION

- A. Shop fabricate for connections to greatest extent possible, including cutting to length and drilling bolt holes.
 - 1. Dress exposed surfaces as needed to remove planing and surfacing marks.
- B. Camber: Fabricate horizontal and inclined members of less than 1:1 slope with either circular or parabolic camber equal to 1/500 of span.
- C. End-Cut Sealing: Immediately after end cutting each member to final length, apply a saturation coat of end sealer to ends and other cross-cut surfaces, keeping surfaces flood coated for not less than 10 minutes.
- D. Seal Coat: After fabricating, sanding, and end-coat sealing, apply a heavy saturation coat of penetrating sealer on surfaces of each unit.

PART 22 - EXECUTION

22.1 EXAMINATION

- A. Examine substrates in areas to receive structural glued-laminated timber, with Installer present, for compliance with requirements, installation tolerances, and other conditions affecting performance of the Work.
- B. Proceed with installation only after unsatisfactory conditions have been corrected.

22.2 INSTALLATION

- A. General: Erect structural glued-laminated timber true and plumb and with uniform, close-fitting joints. Provide temporary bracing to maintain lines and levels until permanent supporting members are in place.
 - 1. Handle and temporarily support glued-laminated timber to prevent surface damage, compression, and other effects that might interfere with indicated finish.
- B. Framing Built into Masonry: Provide **1/2-inch (13-mm)** clearance at tops, sides, and ends of members built into masonry; bevel cut ends **3 inches (76 mm)**; and do not embed more than **4 inches (102 mm)** unless otherwise indicated.
- C. Cutting: Avoid extra cutting after fabrication. Where field fitting is unavoidable, comply with requirements for shop fabrication.
- D. Fit structural glued-laminated timber by cutting and restoring exposed surfaces to match specified surfacing and finishing.
 - 1. Predrill for fasteners using timber connectors as templates.

2. Finish exposed surfaces to remove planing or surfacing marks and to provide a finish equivalent to that produced by machine sanding with No. 120 grit sandpaper.
3. Coat cross cuts with end sealer.

E. Install timber connectors as indicated.

1. Unless otherwise indicated, install bolts with same orientation within each connection and in similar connections.
2. Install bolts with orientation as indicated or, if not indicated, as directed by Architect.

22.3 ADJUSTING

- A. Repair damaged surfaces and finishes after completing erection. Replace damaged structural glued-laminated timber if repairs are not approved by Engineer.

22.4 PROTECTION

- A. Do not remove wrappings on individually wrapped members until they no longer serve a useful purpose, including protection from weather, sunlight, soiling, and damage from work of other trades.
1. Coordinate wrapping removal with finishing work. Retain wrapping where it can serve as a painting shield.
 2. Slit underside of wrapping to prevent accumulation of moisture inside the wrapping.

END OF SECTION 061800

SECTION 074113.16

STANDING-SEAM METAL ROOF PANELS

PART 23 - GENERAL

23.1 RELATED DOCUMENTS

- A. Drawings and general provisions of the Contract - Standard Specifications for Public Works Construction 'The GREENBOOK' and City Supplement 'The WHITEBOOK', latest editions, including Supplemental Supplementary Provisions (SSPs), apply to this Section.

23.2 SUMMARY

- A. Section includes standing-seam metal roof panels.

23.3 PREINSTALLATION MEETINGS

- A. Preinstallation Conference: Conduct conference at Project site.
 - 1. Meet with Owner, Engineer, City's insurer if applicable, metal panel Installer, metal panel manufacturer's representative, structural-support Installer, and installers whose work interfaces with or affects metal panels, including installers of roof accessories and roof-mounted equipment.
 - 2. Review and finalize construction schedule and verify availability of materials, Installer's personnel, equipment, and facilities needed to make progress and avoid delays.
 - 3. Review methods and procedures related to metal panel installation, including manufacturer's written instructions.
 - 4. Examine support conditions for compliance with requirements, including alignment between and attachment to structural members.
 - 5. Review structural loading limitations of deck during and after roofing.
 - 6. Review flashings, special details, drainage, penetrations, equipment curbs, and condition of other construction that affect metal panels.
 - 7. Review governing regulations and requirements for insurance, certificates, and tests and inspections if applicable.
 - 8. Review temporary protection requirements for metal panel systems during and after installation.
 - 9. Review procedures for repair of metal panels damaged after installation.
 - 10. Document proceedings, including corrective measures and actions required, and furnish copy of record to each participant.

23.4 ACTION SUBMITTALS

- A. Product Data: For each type of product.
 - 1. Include construction details, material descriptions, dimensions of individual components and profiles, and finishes for each type of panel and accessory.

- B. Shop Drawings:
 - 1. Include fabrication and installation layouts of metal panels; details of edge conditions, joints, panel profiles, corners, anchorages, attachment system, trim, flashings, closures, and accessories; and special details.
 - 2. Accessories: Include details of the flashing, trim, and anchorage systems, at a scale of not less than 1-1/2 inches per 12 inches (1:10).
- C. Samples for Verification: For each type of exposed finish required, prepared on Samples of size indicated below.
 - 1. Metal Panels: 12 inches (305 mm) long by actual panel width. Include clips, fasteners, closures, and other metal panel accessories.

23.5 INFORMATIONAL SUBMITTALS

- A. Qualification Data: For Installer.
- B. Product Test Reports: For each product, for tests performed by a qualified testing agency.
- C. Field quality-control reports.
- D. Sample Warranties: For special warranties.

23.6 CLOSEOUT SUBMITTALS

- A. Maintenance Data: For metal panels to include in maintenance manuals.

23.7 QUALITY ASSURANCE

- A. Installer Qualifications: An entity that employs installers and supervisors who are trained and approved by manufacturer.

23.8 DELIVERY, STORAGE, AND HANDLING

- A. Deliver components, metal panels, and other manufactured items so as not to be damaged or deformed. Package metal panels for protection during transportation and handling.
- B. Unload, store, and erect metal panels in a manner to prevent bending, warping, twisting, and surface damage.
- C. Stack metal panels horizontally on platforms or pallets, covered with suitable weathertight and ventilated covering. Store metal panels to ensure dryness, with positive slope for drainage of water. Do not store metal panels in contact with other materials that might cause staining, denting, or other surface damage.
- D. Retain strippable protective covering on metal panels during installation.

23.9 FIELD CONDITIONS

- A. Weather Limitations: Proceed with installation only when existing and forecasted weather conditions permit assembly of metal panels to be performed according to manufacturers' written instructions and warranty requirements.

23.10 COORDINATION

- A. Coordinate sizes and locations of roof curbs, equipment supports, and roof penetrations with actual equipment provided.
- B. Coordinate metal panel installation with rain drainage work, flashing, trim, construction of soffits, and other adjoining work to provide a leakproof, secure, and noncorrosive installation.

23.11 WARRANTY

- A. Special Warranty: Manufacturer's standard form in which manufacturer agrees to repair or replace components of metal panel systems that fail in materials or workmanship within specified warranty period.
 - 1. Failures include, but are not limited to, the following:
 - a. Structural failures including rupturing, cracking, or puncturing.
 - b. Deterioration of metals and other materials beyond normal weathering.
 - 2. Warranty Period: Two years from date of Substantial Completion.
- B. Special Warranty on Panel Finishes: Manufacturer's standard form in which manufacturer agrees to repair finish or replace metal panels that show evidence of deterioration of factory-applied finishes within specified warranty period.
 - 1. Exposed Panel Finish: Deterioration includes, but is not limited to, the following:
 - a. Color fading more than 5 Hunter units when tested according to ASTM D 2244.
 - b. Chalking in excess of a No. 8 rating when tested according to ASTM D 4214.
 - c. Cracking, checking, peeling, or failure of paint to adhere to bare metal.
 - 2. Finish Warranty Period: 20 years from date of Substantial Completion.

23.12 REGULATORY REQUIREMENTS

- A. Roof must be installed in accordance with ICC ESR-2385 as indicated on Drawings.

PART 24 - PRODUCTS

24.1 PERFORMANCE REQUIREMENTS

- A. Energy Performance: Provide roof panels that are listed on the EPA/DOE's ENERGY STAR "Roof Product List" for low-slope roof products.
- B. Energy Performance: Provide roof panels according to one of the following when tested according to CRRC-1:
 - 1. Three-year, aged solar reflectance of not less than 0.55 and emissivity of not less than 0.75.
 - 2. Three-year, aged Solar Reflectance Index of not less than 64 when calculated according to ASTM E 1980.
- C. Structural Performance: Provide metal panel systems capable of withstanding the effects of the following loads, based on testing according to ASTM E 1592:
 - 1. Wind Loads: As indicated on Drawings.
 - 2. Other Design Loads: As indicated on Drawings.
 - 3. Deflection Limits: For wind loads, no greater than 1/240 of the span.
- D. Wind-Uplift Resistance: Provide metal roof panel assemblies that comply with UL 580 for wind-uplift-resistance class indicated.
 - 1. Uplift Rating: UL 90.
- E. Thermal Movements: Allow for thermal movements from ambient and surface temperature changes by preventing buckling, opening of joints, overstressing of components, failure of joint sealants, failure of connections, and other detrimental effects. Base calculations on surface temperatures of materials due to both solar heat gain and nighttime-sky heat loss.
 - 1. Temperature Change (Range): 120 deg F (67 deg C), ambient; 180 deg F (100 deg C), material surfaces.
- F. Metal Panel Sealant Requirement:
 - 1. Applied lap sealant is required at any lapping metal panel roof sloping less than three units vertical in 12 units horizontal per CBC Section 1507.4.2.
 - 2. Provide continuous lap sealant at every panel joint. Lap sealants shall be applied in accordance with the approved manufacturer's installation instructions.
- G. Install in accordance with ICC ESR-2385, Class A application.

24.2 STANDING-SEAM METAL ROOF PANELS

- A. General: Provide factory-formed metal roof panels designed to be installed by lapping and interconnecting raised side edges of adjacent panels with joint type indicated and mechanically attaching panels to supports using concealed clips in side laps. Include clips, cleats, pressure plates, and accessories required for weathertight installation.
 - 1. Steel Panel Systems: Unless more stringent requirements are indicated, comply with ASTM E 1514.

- B. Integral-Standing-Seam Metal Roof Panels: Formed with integral ribs at panel edges and intermediate stiffening ribs symmetrically spaced between ribs; designed for sequential installation by mechanically attaching panels to supports using concealed clips located under one side of panels and lapping and interconnecting side edges of adjacent panels.
1. Manufacturers: Subject to compliance with requirements, provide products by one of the following:
 - a. ATAS International, Inc.
 - b. Metal Sales Manufacturing Corporation.
 - c. Morin - A Kingspan Group Company.
 2. Metallic-Coated Steel Sheet: Zinc-coated (galvanized) steel sheet complying with ASTM A 653/A 653M, **G90 (Z275)** coating designation, or aluminum-zinc alloy-coated steel sheet complying with ASTM A 792/A 792M, **Class AZ50 (Class AZM150)** coating designation; structural quality. Prepainted by the coil-coating process to comply with ASTM A 755/A 755M.
 - a. Nominal Thickness: 24 gauge.
 - b. Exterior Finish: Two-coat fluoropolymer.
 - c. Color: As selected by Engineer from manufacturer's full range.
 3. Clips: One-piece fixed to accommodate thermal movement.
 - a. Material: **0.064-inch- (1.63-mm-)** nominal thickness, zinc-coated (galvanized) or aluminum-zinc alloy-coated steel sheet.
 4. Panel Coverage: 16 inches.
 5. Panel Height: 1.75 inch.

24.3 UNDERLAYMENT MATERIALS

- A. Self-Adhering, High-Temperature Underlayment: Provide self-adhering, cold-applied, sheet underlayment, a minimum of **30 mils (0.76 mm)** thick, consisting of slip-resistant, polyethylene-film top surface laminated to a layer of butyl or SBS-modified asphalt adhesive, with release-paper backing. Provide primer when recommended by underlayment manufacturer.
1. Thermal Stability: Stable after testing at **240 deg F (116 deg C)**; ASTM D 1970.
 2. Low-Temperature Flexibility: Passes after testing at minus **20 deg F (29 deg C)**; ASTM D 1970.
- B. Fire-Resistant Slip Sheet: VersaShield Fire-Resistant Roof Deck Protection as required by ICC ESR-2385.

24.4 MISCELLANEOUS MATERIALS

- A. Miscellaneous Metal Subframing and Furring: ASTM C 645; cold-formed, metallic-coated steel sheet, ASTM A 653/A 653M, **G90 (Z275 hot-dip galvanized)** coating designation or ASTM A 792/A 792M, **Class AZ50 (Class AZM150)** coating designation unless otherwise indicated. Provide manufacturer's standard sections as required for support and alignment of metal panel system.

- B. Panel Accessories: Provide components required for a complete, weathertight panel system including trim, copings, fasciae, mullions, sills, corner units, clips, flashings, sealants, gaskets, fillers, closure strips, and similar items. Match material and finish of metal panels unless otherwise indicated.
 - 1. Closures: Provide closures at eaves and ridges, fabricated of same metal as metal panels.
 - 2. Backing Plates: Provide metal backing plates at panel end splices, fabricated from material recommended by manufacturer.
 - 3. Closure Strips: Closed-cell, expanded, cellular, rubber or crosslinked, polyolefin-foam or closed-cell laminated polyethylene; minimum 1-inch- (25-mm-) thick, flexible closure strips; cut or premolded to match metal panel profile. Provide closure strips where indicated or necessary to ensure weathertight construction.
- C. Flashing and Trim: Provide flashing and trim formed from same material as metal panels as required to seal against weather and to provide finished appearance. Locations include, but are not limited to, eaves, rakes, corners, bases, framed openings, ridges, fasciae, and fillers. Finish flashing and trim with same finish system as adjacent metal panels.
- D. Downspouts: Schedule 40 pipe, refer to Section 076200 – “Sheet Metal Flashing and Trim.”
- E. Roof Curbs: Fabricated from same material as roof panels, 0.048-inch (1.2-mm) nominal thickness; with bottom of skirt profiled to match roof panel profiles and with welded top box and integral full-length cricket. Fabricate curb subframing of 0.060-inch- (1.52-mm-) nominal thickness, angle-, C-, or Z-shaped steel sheet. Fabricate curb and subframing to withstand indicated loads of size and height indicated. Finish roof curbs to match metal roof panels.
 - 1. Insulate roof curb with 1-inch- (25-mm-) thick, rigid insulation.
- F. Panel Fasteners: Self-tapping screws designed to withstand design loads.
- G. Panel Sealants: Provide sealant type recommended by manufacturer that are compatible with panel materials, are nonstaining, and do not damage panel finish.
 - 1. Sealant Tape: Pressure-sensitive, 100 percent solids, gray polyisobutylene compound sealant tape with release-paper backing. Provide permanently elastic, nonsag, nontoxic, nonstaining tape 1/2 inch (13 mm) wide and 1/8 inch (3 mm) thick.
 - 2. Joint Sealant: ASTM C 920; elastomeric polyurethane or silicone sealant; of type, grade, class, and use classifications required to seal joints in metal panels and remain weathertight; and as recommended in writing by metal panel manufacturer.
 - 3. Butyl-Rubber-Based, Solvent-Release Sealant: ASTM C 1311.

24.5 FABRICATION

- A. General: Fabricate and finish metal panels and accessories at the factory, by manufacturer's standard procedures and processes, as necessary to fulfill indicated performance requirements demonstrated by laboratory testing. Comply with indicated profiles and with dimensional and structural requirements.
- B. Provide panel profile, including major ribs and intermediate stiffening ribs, if any, for full length of panel.

- C. Fabricate metal panel joints with factory-installed captive gaskets or separator strips that provide a weathertight seal and prevent metal-to-metal contact, and that minimize noise from movements.
- D. Sheet Metal Flashing and Trim: Fabricate flashing and trim to comply with manufacturer's recommendations and recommendations in SMACNA's "Architectural Sheet Metal Manual" that apply to design, dimensions, metal, and other characteristics of item indicated.
 - 1. Form exposed sheet metal accessories that are without excessive oil canning, buckling, and tool marks and that are true to line and levels indicated, with exposed edges folded back to form hems.
 - 2. Seams for Other Than Aluminum: Fabricate nonmoving seams in accessories with flat-lock seams. Tin edges to be seamed, form seams, and solder.
 - 3. Sealed Joints: Form nonexpansion, but movable, joints in metal to accommodate sealant and to comply with SMACNA standards.
 - 4. Conceal fasteners and expansion provisions where possible. Exposed fasteners are not allowed on faces of accessories exposed to view.
 - 5. Fabricate cleats and attachment devices from same material as accessory being anchored or from compatible, noncorrosive metal recommended in writing by metal panel manufacturer.
 - a. Size: As recommended by SMACNA's "Architectural Sheet Metal Manual" or metal panel manufacturer for application, but not less than thickness of metal being secured.

24.6 FINISHES

- A. Protect mechanical and painted finishes on exposed surfaces from damage by applying a strippable, temporary protective covering before shipping.
- B. Appearance of Finished Work: Variations in appearance of abutting or adjacent pieces are acceptable if they are within one-half of the range of approved Samples. Noticeable variations in same piece are unacceptable. Variations in appearance of other components are acceptable if they are within the range of approved Samples and are assembled or installed to minimize contrast.
- C. Steel Panels and Accessories:
 - 1. Two-Coat Fluoropolymer: AAMA 621. Fluoropolymer finish containing not less than 70 percent PVDF resin by weight in both color coat and clear topcoat. Prepare, pretreat, and apply coating to exposed metal surfaces to comply with coating and resin manufacturers' written instructions.
 - 2. Concealed Finish: Apply pretreatment and manufacturer's standard white or light-colored acrylic or polyester backer finish consisting of prime coat and wash coat with a minimum total dry film thickness of 0.5 mil (0.013 mm).

PART 25 - EXECUTION

25.1 EXAMINATION

- A. Examine substrates, areas, and conditions, with Installer present, for compliance with requirements for installation tolerances, metal panel supports, and other conditions affecting performance of the Work.
 - 1. Examine primary and secondary roof framing to verify that rafters, purlins, angles, channels, and other structural panel support members and anchorages have been installed within alignment tolerances required by metal roof panel manufacturer.
 - 2. Examine solid roof sheathing to verify that sheathing joints are supported by framing or blocking and that installation is within flatness tolerances required by metal roof panel manufacturer.
- B. Examine roughing-in for components and systems penetrating metal panels to verify actual locations of penetrations relative to seam locations of metal panels before installation.
- C. Proceed with installation only after unsatisfactory conditions have been corrected.

25.2 PREPARATION

- A. Miscellaneous Supports: Install subframing, furring, and other miscellaneous panel support members and anchorages according to ASTM C 754 and metal panel manufacturer's written recommendations.

25.3 UNDERLAYMENT INSTALLATION

- A. Self-Adhering Sheet Underlayment: Apply primer if required by manufacturer. Comply with temperature restrictions of underlayment manufacturer for installation. Apply at locations indicated below, wrinkle free, in shingle fashion to shed water, and with end laps of not less than 6 inches (152 mm) staggered 24 inches (610 mm) between courses. Overlap side edges not less than 3-1/2 inches (90 mm). Roll laps with roller. Cover underlayment within 14 days.
 - 1. Apply over the entire roof surface.
- B. Fire-Resistant Slip Sheet: Apply slip sheet over underlayment before installing metal roof panels.
- C. Flashings: Install flashings to cover underlayment to comply with requirements specified in Section 076200 "Sheet Metal Flashing and Trim."

25.4 METAL PANEL INSTALLATION

- A. General: Install metal panels according to manufacturer's written instructions in orientation, sizes, and locations indicated. Install panels perpendicular to supports unless otherwise indicated. Anchor metal panels and other components of the Work securely in place, with provisions for thermal and structural movement.

1. Shim or otherwise plumb substrates receiving metal panels.
 2. Flash and seal metal panels at perimeter of all openings. Fasten with self-tapping screws. Do not begin installation until air- or water-resistive barriers and flashings that will be concealed by metal panels are installed.
 3. Install screw fasteners in predrilled holes.
 4. Locate and space fastenings in uniform vertical and horizontal alignment.
 5. Install flashing and trim as metal panel work proceeds.
 6. Locate panel splices over, but not attached to, structural supports. Stagger panel splices and end laps to avoid a four-panel lap splice condition.
 7. Align bottoms of metal panels and fasten with blind rivets, bolts, or self-tapping screws. Fasten flashings and trim around openings and similar elements with self-tapping screws.
 8. Provide weathertight escutcheons for pipe- and conduit-penetrating panels.
- B. Fasteners:
1. Steel Panels: Use stainless-steel fasteners for surfaces exposed to the exterior; use galvanized-steel fasteners for surfaces exposed to the interior.
- C. Anchor Clips: Anchor metal roof panels and other components of the Work securely in place, using manufacturer's approved fasteners according to manufacturers' written instructions.
- D. Metal Protection: Where dissimilar metals contact each other or corrosive substrates, protect against galvanic action as recommended in writing by metal panel manufacturer.
- E. Standing-Seam Metal Roof Panel Installation: Fasten metal roof panels to supports with concealed clips at each standing-seam joint at location, spacing, and with fasteners recommended in writing by manufacturer.
1. Install clips to supports with self-tapping fasteners.
 2. Install pressure plates at locations indicated in manufacturer's written installation instructions.
 3. Snap Joint: Nest standing seams and fasten together by interlocking and completely engaging factory-applied sealant.
- F. Accessory Installation: Install accessories with positive anchorage to building and weathertight mounting, and provide for thermal expansion. Coordinate installation with flashings and other components.
1. Install components required for a complete metal panel system including trim, copings, corners, seam covers, flashings, sealants, gaskets, fillers, closure strips, and similar items. Provide types indicated by metal roof panel manufacturers; or, if not indicated, types recommended by metal roof panel manufacturer.
- G. Flashing and Trim: Comply with performance requirements, manufacturer's written installation instructions, and SMACNA's "Architectural Sheet Metal Manual." Provide concealed fasteners where possible, and set units true to line and level as indicated. Install work with laps, joints, and seams that will be permanently watertight and weather resistant.
1. Install exposed flashing and trim that is without buckling and tool marks, and that is true to line and levels indicated, with exposed edges folded back to form hems. Install

sheet metal flashing and trim to fit substrates and achieve waterproof and weather-resistant performance.

2. Expansion Provisions: Provide for thermal expansion of exposed flashing and trim. Space movement joints at a maximum of **10 feet (3 m)** with no joints allowed within **24 inches (610 mm)** of corner or intersection. Where lapped expansion provisions cannot be used or would not be sufficiently weather resistant and waterproof, form expansion joints of intermeshing hooked flanges, not less than **1 inch (25 mm)** deep, filled with mastic sealant (concealed within joints).
- H. Gutters: Join sections with riveted and soldered or lapped and sealed joints. Attach gutters to eave with gutter hangers spaced not more than **36 inches (914 mm)** o.c. using manufacturer's standard fasteners. Provide end closures and seal watertight with sealant. Provide for thermal expansion.
- I. Downspouts: Join sections with telescoping joints. Provide fasteners designed to hold downspouts securely **1 inch (25 mm)** away from walls; locate fasteners at top and bottom and at approximately **60 inches (1524 mm)** o.c. in between.
1. Connect downspouts to underground drainage system indicated.
- J. Roof Curbs: Install flashing around bases where they meet metal roof panels.
- K. Pipe Flashing: Form flashing around pipe penetration and metal roof panels. Fasten and seal to metal roof panels as recommended by manufacturer.

25.5 ERECTION TOLERANCES

- A. Installation Tolerances: Shim and align metal panel units within installed tolerance of **1/4 inch in 20 feet (6 mm in 6 m)** on slope and location lines as indicated and within **1/8-inch (3-mm)** offset of adjoining faces and of alignment of matching profiles.

25.6 FIELD QUALITY CONTROL

- A. Manufacturer's Field Service: Engage a factory-authorized service representative to test and inspect metal roof panel installation, including accessories. Report results in writing.
- B. Remove and replace applications of metal roof panels where tests and inspections indicate that they do not comply with specified requirements.
- C. Additional tests and inspections, at Contractor's expense, are performed to determine compliance of replaced or additional work with specified requirements.
- D. Prepare test and inspection reports.

25.7 CLEANING AND PROTECTION

- A. Remove temporary protective coverings and strippable films, if any, as metal panels are installed, unless otherwise indicated in manufacturer's written installation instructions. On completion of metal panel installation, clean finished surfaces as recommended by metal panel manufacturer. Maintain in a clean condition during construction.

- B. Replace metal panels that have been damaged or have deteriorated beyond successful repair by finish touchup or similar minor repair procedures.

END OF SECTION 074113.16

SECTION 074646
FIBER-CEMENT SOFFIT

PART 26 - GENERAL

26.1 RELATED DOCUMENTS

- A. Drawings and general provisions of the Contract - Standard Specifications for Public Works Construction 'The GREENBOOK' and City Supplement 'The WHITEBOOK', latest editions, including Supplemental Supplementary Provisions (SSPs), apply to this Section.

26.2 SUMMARY

- A. Section includes fiber-cement soffit.
- B. Related Requirements:
 - 1. Section 061000 "Rough Carpentry" for wood furring, grounds, nailers, and blocking.

26.3 COORDINATION

- A. Coordinate siding installation with flashings and other adjoining construction to ensure proper sequencing.

26.4 PREINSTALLATION MEETINGS

- A. Preinstallation Conference: Conduct conference at Project site.

26.5 ACTION SUBMITTALS

- A. Product Data: For each type of product. Include construction details, material descriptions, dimensions of individual components and profiles, and finishes.
- B. Samples for Initial Selection: For fiber-cement soffit including related accessories.
- C. Samples for Verification: For each type, color, texture, and pattern required.
 - 1. 12-inch- (300-mm-) long-by-actual-width Sample of soffit.
 - 2. 12-inch- (300-mm-) long-by-actual-width Samples of trim and accessories.

26.6 INFORMATIONAL SUBMITTALS

- A. Product Certificates: For each type of fiber-cement soffit.
- B. Product Test Reports: Based on evaluation of comprehensive tests performed by a qualified testing agency, for fiber-cement siding.

- C. Research/Evaluation Reports: For each type of fiber-cement siding required, from ICC-ES.
- D. Sample Warranty: For special warranty.

26.7 CLOSEOUT SUBMITTALS

- A. Maintenance Data: For each type of product, including related accessories, to include in maintenance manuals.

26.8 MAINTENANCE MATERIAL SUBMITTALS

- A. Furnish extra materials that match products installed and that are packaged with protective covering for storage and identified with labels describing contents.
 - 1. Furnish full lengths of fiber-cement soffit including related accessories, in a quantity equal to 2 percent of amount installed.

26.9 DELIVERY, STORAGE, AND HANDLING

- A. Deliver and store packaged materials in original containers with labels intact until time of use.
- B. Store materials on elevated platforms, under cover, and in a dry location.

26.10 WARRANTY

- A. Special Warranty: Manufacturer agrees to repair or replace products that fail in materials or workmanship within specified warranty period.
 - 1. Failures include, but are not limited to, the following:
 - a. Structural failures including cracking and deforming.
 - b. Deterioration of materials beyond normal weathering.
 - 2. Warranty Period: 10 years from date of Substantial Completion.

PART 27 - PRODUCTS

27.1 MANUFACTURERS

- A. Source Limitations: Obtain products, including related accessories, from single source from single manufacturer.

27.2 FIBER-CEMENT SOFFIT

- A. General: ASTM C 1186, Type A, Grade II, fiber-cement board, noncombustible when tested according to ASTM E 136; with a flame-spread index of 25 or less when tested according to ASTM E 84.
 - 1. Manufacturers: Subject to compliance with requirements, provide products by the following:
 - a. James Hardie Building Products, Inc.
 - b. Approved equal.
- B. Nominal Thickness: Not less than **5/16 inch (8 mm)**.
- C. Pattern: **12-inch- (300-mm-)** wide sheets with smooth texture.
- D. Ventilation: Provide perforated soffit.
- E. Factory Priming: Manufacturer's standard acrylic primer.

27.3 ACCESSORIES

- A. Siding Accessories, General: Provide starter strips, edge trim, outside and inside corner caps, and other items as recommended by siding manufacturer for building configuration.
 - 1. Provide accessories matching color and texture of adjacent siding unless otherwise indicated.
- B. Fasteners:
 - 1. For fastening to wood, use pancake head wood screws of sufficient length to penetrate a minimum of **1 inch (25 mm)** into substrate.
 - 2. For fastening fiber cement, use stainless-steel fasteners.
- C. Sealant per "Section 079200 – Joint Sealants".
- D. Paint finish per "Section 099600 – High-Performance Coatings".

PART 28 - EXECUTION

28.1 EXAMINATION

- A. Examine substrates for compliance with requirements for installation tolerances and other conditions affecting performance of fiber-cement soffit and related accessories.
- B. Proceed with installation only after unsatisfactory conditions have been corrected.

28.2 PREPARATION

- A. Clean substrates of projections and substances detrimental to application.

28.3 INSTALLATION

- A. General: Comply with manufacturer's written installation instructions applicable to products and applications indicated unless more stringent requirements apply.
 - 1. Do not install damaged components.
 - 2. Install fasteners no more than 16 inches o.c.
 - 3. Provide continuous 2x4 backing at all joints not backed up by structural members.
- B. Install joint sealants as specified in Section 079200 "Joint Sealants" and to produce a weathertight installation.
 - 1. All perimeter and all panel-to-panel joints shall be sealed and tooled flush with panel face.
- C. Finish in accordance with "Section 099600 – High-Performance Coatings".

28.4 ADJUSTING AND CLEANING

- A. Remove damaged, improperly installed, or otherwise defective materials and replace with new materials complying with specified requirements.
- B. Clean finished surfaces according to manufacturer's written instructions and maintain in a clean condition during construction.

END OF SECTION 074646

SECTION 07 62 00

SHEET METAL FLASHING AND TRIM

PART 29 - GENERAL

29.1 RELATED DOCUMENTS

- A. Drawings and general provisions of the Contract - Standard Specifications for Public Works Construction 'The GREENBOOK' and City Supplement 'The WHITEBOOK', latest editions, including Supplemental Supplementary Provisions (SSPs), apply to this Section.

29.2 SUMMARY

- A. Section Includes:
 - 1. Low slope roof sheet metal fabrications.
 - 2. Formed equipment support flashing.
- B. Related Requirements:
 - 1. Section 061000 "Rough Carpentry" for wood nailers, curbs, and blocking.
 - 2. Section 074113.16 "Standing-Seam Metal Roof Panels" for materials and installation of sheet metal flashing and trim integral with roofing.

29.3 COORDINATION

- A. Coordinate sheet metal flashing and trim layout and seams with sizes and locations of penetrations to be flashed, and joints and seams in adjacent materials.
- B. Coordinate sheet metal flashing and trim installation with adjoining roofing and wall materials, joints, and seams to provide leakproof, secure, and noncorrosive installation.

29.4 PREINSTALLATION MEETINGS

- A. Preinstallation Conference: Conduct conference at Project site.
 - 1. Review construction schedule. Verify availability of materials, Installer's personnel, equipment, and facilities needed to make progress and avoid delays.
 - 2. Review special roof details, roof drainage, roof-penetration flashing, equipment curbs, and condition of other construction that affect sheet metal flashing and trim.
 - 3. Review requirements for insurance and certificates if applicable.
 - 4. Review sheet metal flashing observation and repair procedures after flashing installation.

29.5 ACTION SUBMITTALS

- A. Product Data: For each of the following

1. Underlayment materials.
2. Elastomeric sealant.
3. Butyl sealant.
4. Epoxy seam sealer.

B. Shop Drawings: For sheet metal flashing and trim.

1. Include plans, elevations, sections, and attachment details.
2. Detail fabrication and installation layouts, expansion-joint locations, and keyed details. Distinguish between shop- and field-assembled Work.
3. Include identification of material, thickness, weight, and finish for each item and location in Project.
4. Include details for forming, including profiles, shapes, seams, and dimensions.
5. Include details for joining, supporting, and securing, including layout and spacing of fasteners, cleats, clips, and other attachments. Include pattern of seams.
6. Include details of termination points and assemblies.
7. Include details of expansion joints and expansion-joint covers, including showing direction of expansion and contraction from fixed points.
8. Include details of roof-penetration flashing.
9. Include details of edge conditions, including eaves, ridges, valleys, rakes, crickets, flashings, and counterflashings.
10. Include details of special conditions.
11. Include details of connections to adjoining work.
12. Detail formed flashing and trim at scale of not less than **3 inches per 12 inches**.

C. Samples: For each exposed product and for each color and texture specified, **12 inches (300 mm)** long by actual width.

D. Samples for Verification: For each type of exposed finish.

1. Sheet Metal Flashing: **12 inches (300 mm)** long by actual width of unit, including finished seam and in required profile. Include fasteners, cleats, clips, closures, and other attachments.
2. Trim, Metal Closures, Expansion Joints, Joint Intersections, and Miscellaneous Fabrications: **12 inches (300 mm)** long and in required profile. Include fasteners and other exposed accessories.
3. Unit-Type Accessories and Miscellaneous Materials: Full-size Sample.
4. Anodized Aluminum Samples: Samples to show full range to be expected for each color required.

29.6 INFORMATIONAL SUBMITTALS

A. Qualification Data: For fabricator.

B. Product Certificates: For each type of coping and roof edge flashing that is ANSI/SPRI/FM 4435/ES-1 tested.

C. Product Test Reports: For each product, for tests performed by a qualified testing agency.

D. Evaluation Reports: For copings and roof edge flashing, from an agency acceptable to authority having jurisdiction showing compliance with ANSI/SPRI/FM 4435/ES-1.

- E. Sample Warranty: For special warranty.

29.7 CLOSEOUT SUBMITTALS

- A. Maintenance Data: For sheet metal flashing and trim, and its accessories, to include in maintenance manuals.
- B. Special warranty.

29.8 QUALITY ASSURANCE

- A. Fabricator Qualifications: Employs skilled workers who custom fabricate sheet metal flashing and trim similar to that required for this Project and whose products have a record of successful in-service performance.
 - 1. For copings and roof edge flashings that are ANSI/SPRI/FM 4435/ES-1 tested, shop shall be listed as able to fabricate required details as tested and approved.
- B. Mockups: Build mockups to verify selections made under Sample submittals, to demonstrate aesthetic effects, and to set quality standards for fabrication and installation.
 - 1. Build mockup of typical roof eave, including fascia, approximately 10 feet (3.0 m) long, including supporting construction cleats, seams, attachments, underlayment, and accessories.
 - 2. Approval of mockups does not constitute approval of deviations from the Contract Documents contained in mockups unless Owner specifically approves such deviations in writing.
 - 3. Subject to compliance with requirements, approved mockups may become part of the completed Work if undisturbed at time of Substantial Completion.

29.9 DELIVERY, STORAGE, AND HANDLING

- A. Do not store sheet metal flashing and trim materials in contact with other materials that might cause staining, denting, or other surface damage.
 - 1. Store sheet metal flashing and trim materials away from uncured concrete and masonry.
 - 2. Protect stored sheet metal flashing and trim from contact with water.
- B. Protect strippable protective covering on sheet metal flashing and trim from exposure to sunlight and high humidity, except to extent necessary for period of sheet metal flashing and trim installation.

29.10 WARRANTY

- A. Special Warranty on Finishes: Manufacturer agrees to repair finish or replace sheet metal flashing and trim that shows evidence of deterioration of factory-applied finishes within specified warranty period.
 - 1. Exposed Panel Finish: Deterioration includes, but is not limited to, the following:

- a. Color fading more than 5 Delta units when tested in accordance with ASTM D2244.
 - b. Chalking in excess of a No. 8 rating when tested in accordance with ASTM D4214.
 - c. Cracking, checking, peeling, or failure of paint to adhere to bare metal.
2. Finish Warranty Period: 20 years from date of Substantial Completion.

PART 30 - PRODUCTS

30.1 PERFORMANCE REQUIREMENTS

- A. General: Sheet metal flashing and trim assemblies, including cleats, anchors, and fasteners, shall withstand wind loads, structural movement, thermally induced movement, and exposure to weather without failure due to defective manufacture, fabrication, installation, or other defects in construction. Completed sheet metal flashing and trim shall not rattle, leak, or loosen, and shall remain watertight.
- B. Sheet Metal Standard for Flashing and Trim: Comply with NRCA's "The NRCA Roofing Manual: Architectural Metal Flashing, Condensation and Air Leakage Control, and Reroofing" and SMACNA's "Architectural Sheet Metal Manual" requirements for dimensions and profiles shown unless more stringent requirements are indicated.
- C. SPRI Wind Design Standard: Manufacture and install roof edge flashings tested in accordance with ANSI/SPRI/FM 4435/ES-1 and capable of resisting the following design pressure:
 1. Design Pressure: As indicated on Drawings.
- D. Thermal Movements: Allow for thermal movements from ambient and surface temperature changes to prevent buckling, opening of joints, overstressing of components, failure of joint sealants, failure of connections, and other detrimental effects. Base calculations on surface temperatures of materials due to both solar heat gain and nighttime-sky heat loss.
 1. Temperature Change: 120 deg F (67 deg C), ambient; 180 deg F (100 deg C), material surfaces.

30.2 SHEET METALS

- A. General: Protect mechanical and other finishes on exposed surfaces from damage by applying strippable, temporary protective film before shipping.
- B. Metallic-Coated Steel Sheet: Provide zinc-coated (galvanized) steel sheet in accordance with ASTM A653/A653M, G90 (Z275) coating designation; prepainted by coil-coating process to comply with ASTM A755/A755M.
 1. Surface: Smooth, flat.
 2. Exposed Coil-Coated Finish:
 - a. Two-Coat Fluoropolymer: AAMA 621. Fluoropolymer finish containing not less than 70 percent polyvinylidene fluoride (PVDF) resin by weight in color coat.

Prepare, pretreat, and apply coating to exposed metal surfaces to comply with coating and resin manufacturers' written instructions.

3. Color: As selected by Engineer from manufacturer's full range.
4. Concealed Finish: Pretreat with manufacturer's standard white or light-colored acrylic or polyester backer finish, consisting of prime coat and wash coat with minimum total dry film thickness of **0.5 mil (0.013 mm)**.

30.3 UNDERLAYMENT MATERIALS

- A. Self-Adhering, High-Temperature Sheet Underlayment: Minimum **30 mils (0.76 mm)** thick, consisting of a slip-resistant polyethylene- or polypropylene-film top surface laminated to a layer of butyl- or SBS-modified asphalt adhesive, with release-paper backing; specifically designed to withstand high metal temperatures beneath metal roofing. Provide primer in accordance with underlayment manufacturer's written instructions.
 1. Source Limitations: Obtain underlayment from single source from single manufacturer.
 2. Low-Temperature Flexibility: ASTM D1970/D1970M; passes after testing at minus **20 deg F (29 deg C)** or lower.
- B. Slip Sheet: VersaShield Fire-Resistant Roof Deck Protection as required by ICC ESR-2385 Class A installation.

30.4 MISCELLANEOUS MATERIALS

- A. General: Provide materials and types of fasteners, solder, protective coatings, sealants, and other miscellaneous items as required for complete sheet metal flashing and trim installation and as recommended by manufacturer of primary sheet metal or manufactured item unless otherwise indicated.
- B. Fasteners: Wood screws as indicated on Drawings, annular threaded nails, self-tapping screws, self-locking rivets and bolts, and other suitable fasteners designed to withstand design loads and recommended by manufacturer of primary sheet metal or manufactured item.
 1. General: Blind fasteners or self-drilling screws, gasketed, with hex-washer head.
 - a. Exposed Fasteners: Heads matching color of sheet metal using plastic caps or factory-applied coating. Provide metal-backed EPDM or PVC sealing washers under heads of exposed fasteners bearing on weather side of metal.
 - b. Blind Fasteners: High-strength aluminum or stainless steel rivets suitable for metal being fastened.
 2. Fasteners for Zinc-Coated (Galvanized) Steel Sheet: Series 300 stainless steel or hot-dip galvanized steel in accordance with ASTM A153/A153M or ASTM F2329.
 3. Fasteners for Zinc Sheet: Series 300 stainless steel or hot-dip galvanized steel in accordance with ASTM A153/A153M or ASTM F2329.
- C. Solder:
 1. For Zinc-Coated (Galvanized) Steel: ASTM B32, Grade Sn50, 50 percent tin and 50 percent lead or Grade Sn60, 60 percent tin and 40 percent lead.

- D. Sealant Tape: Pressure-sensitive, 100 percent solids, polyisobutylene compound sealant tape with release-paper backing. Provide permanently elastic, nonsag, nontoxic, nonstaining tape **1/2 inch (13 mm)** wide and **1/8 inch (3 mm)** thick.
- E. Elastomeric Sealant: ASTM C920, elastomeric silicone polymer sealant; of type, grade, class, and use classifications required to seal joints in sheet metal flashing and trim and remain watertight.
- F. Butyl Sealant: ASTM C1311, single-component, solvent-release butyl rubber sealant; polyisobutylene plasticized; heavy bodied for hooked-type expansion joints with limited movement.
- G. Bituminous Coating: Cold-applied asphalt emulsion in accordance with ASTM D1187/D1187M.

30.5 FABRICATION, GENERAL

- A. Custom fabricate sheet metal flashing and trim to comply with details indicated and recommendations in cited sheet metal standard that apply to design, dimensions, geometry, metal thickness, and other characteristics of item required.
 - 1. Fabricate sheet metal flashing and trim in shop to greatest extent possible.
 - 2. Fabricate sheet metal flashing and trim in thickness or weight needed to comply with performance requirements, but not less than that specified for each application and metal.
 - 3. Verify shapes and dimensions of surfaces to be covered and obtain field measurements for accurate fit before shop fabrication.
 - 4. Form sheet metal flashing and trim to fit substrates without excessive oil-canning, buckling, and tool marks; true to line, levels, and slopes; and with exposed edges folded back to form hems.
 - 5. Conceal fasteners and expansion provisions where possible. Do not use exposed fasteners on faces exposed to view.
- B. Fabrication Tolerances:
 - 1. Fabricate sheet metal flashing and trim that is capable of installation to a tolerance of **1/4 inch in 20 feet (6 mm in 6 m)** on slope and location lines indicated on Drawings and within **1/8-inch (3-mm)** offset of adjoining faces and of alignment of matching profiles.
- C. Expansion Provisions: Form metal for thermal expansion of exposed flashing and trim.
 - 1. Form expansion joints of intermeshing hooked flanges, not less than **1 inch (25 mm)** deep, filled with butyl sealant concealed within joints.
 - 2. Use lapped expansion joints only where indicated on Drawings.
- D. Sealant Joints: Where movable, nonexpansion-type joints are required, form metal in accordance with cited sheet metal standard to provide for proper installation of elastomeric sealant.
- E. Fabricate cleats and attachment devices from same material as accessory being anchored or from compatible, noncorrosive metal.

- F. Fabricate cleats and attachment devices of sizes as recommended by cited sheet metal standard for application, but not less than one gauge heavier than thickness of metal being secured.
- G. Seams:
 - 1. Fabricate nonmoving seams with flat-lock seams. Form seams and seal with elastomeric sealant unless otherwise recommended by sealant manufacturer for intended use. Rivet joints where necessary for strength.
- H. Do not use graphite pencils to mark metal surfaces.

30.6 ROOF-DRAINAGE SHEET METAL FABRICATIONS

- A. Hanging Gutters:
 - 1. Fabricate to cross section required, complete with end pieces, outlet tubes, and other accessories as required.
 - 2. Fabricate in minimum **96-inch- (2400-mm-)** long sections.
 - 3. Furnish flat-stock gutter brackets and flat-stock gutter spacers and straps fabricated from same metal as gutters, of size recommended by cited sheet metal standard, but with thickness not less than 0.125 inch.
 - 4. Fabricate expansion joints, expansion-joint covers, and gutter accessories from same metal as gutters. Shop fabricate interior and exterior corners.
 - 5. Gutter Profile: Style B in accordance with SMACNA sheet metal standard, unless otherwise indicated on Drawings.
 - 6. Expansion Joints: Butt type with cover plate.
 - 7. Accessories: Continuous, removable leaf screen with sheet metal frame and hardware cloth screen, Wire-ball downspout strainer.
 - 8. Gutters with Girth up to **15 Inches (380 mm)**: Fabricate from the following materials:
 - a. Galvanized Steel: **0.028 inch (0.71 mm)** thick.
- B. Downspouts: Steel schedule 40 pipe downspouts to dimensions indicated on Drawings, complete with mitered and welded elbows. Hot dip galvanized after fabrication. Furnish with metal hangers fabricated from hot-dipped galvanized steel, minimum 0.125 x 1 inch flat stock. Shop fabricate elbows.
 - 1. Fabricated Hanger Style: Fig. 1-35J in accordance with SMACNA's "Architectural Sheet Metal Manual."

30.7 LOW-SLOPE ROOF SHEET METAL FABRICATIONS

- A. Roof Edge Flashing and Fascia Cap: Fabricate in minimum **96-inch- (2400-mm-)** long, but not exceeding **12-foot- (3.6-m-)** long sections. Furnish with **6-inch- (150-mm-)** wide, joint cover plates. Shop fabricate interior and exterior corners.
 - 1. Joint Style: Butted with expansion space and **6-inch- (150-mm-)** wide, concealed backup plate.
 - 2. Fabricate from the following materials:
 - a. Same material as metal roof panels, refer to Section 074113.16 "Standing-Seam Metal Roof Panels".
- B. Roof-Penetration Flashing: Fabricate from the following materials:

1. Galvanized Steel: 0.028 inch (0.71 mm) thick. Factory finished to match roofing materials.
2. Manufacturer's roof jack, as compatible and coordinated with roof system and warranty.

PART 31 - EXECUTION

31.1 EXAMINATION

- A. Examine substrates, areas, and conditions, with installer present, for compliance with requirements for installation tolerances, substrate, and other conditions affecting performance of the Work.
 1. Verify compliance with requirements for installation tolerances of substrates.
 2. Verify that substrate is sound, dry, smooth, clean, sloped for drainage, and securely anchored.
- B. Proceed with installation only after unsatisfactory conditions have been corrected.

31.2 INSTALLATION OF UNDERLAYMENT

- A. Self-Adhering, High-Temperature Sheet Underlayment:
 1. Install self-adhering, high-temperature sheet underlayment; wrinkle free.
 2. Prime substrate if recommended by underlayment manufacturer.
 3. Comply with temperature restrictions of underlayment manufacturer for installation; use primer for installing underlayment at low temperatures.
 4. Apply in shingle fashion to shed water, with end laps of not less than 6 inches (150 mm) staggered 24 inches (600 mm) between courses.
 5. Overlap side edges not less than 3-1/2 inches (90 mm). Roll laps and edges with roller.
 6. Roll laps and edges with roller.
 7. Cover underlayment within 14 days.
- B. Install slip sheet, wrinkle free, over underlayment before installing sheet metal flashing and trim.
 1. Install in shingle fashion to shed water.
 2. Lapp joints not less than 4 inches (100 mm).

31.3 INSTALLATION, GENERAL

- A. Install sheet metal flashing and trim to comply with details indicated and recommendations of cited sheet metal standard that apply to installation characteristics required unless otherwise indicated on Drawings.
 1. Install fasteners, protective coatings, separators, sealants, and other miscellaneous items as required to complete sheet metal flashing and trim system.
 2. Install sheet metal flashing and trim true to line, levels, and slopes. Provide uniform, neat seams with minimum exposure of sealant.

3. Anchor sheet metal flashing and trim and other components of the Work securely in place, with provisions for thermal and structural movement.
 4. Install sheet metal flashing and trim to fit substrates and to result in watertight performance.
 5. Install continuous cleats with fasteners spaced not more than **12 inches (300 mm)** o.c.
 6. Install exposed sheet metal flashing and trim with limited oil-canning, and free of buckling and tool marks.
 7. Do not field cut sheet metal flashing and trim by torch.
- B. Metal Protection: Where dissimilar metals contact each other, or where metal contacts pressure-treated wood or other corrosive substrates, protect against galvanic action or corrosion by painting contact surfaces with bituminous coating or by other permanent separation as recommended by sheet metal manufacturer or cited sheet metal standard.
1. Underlayment: Where installing sheet metal flashing and trim directly on cementitious or wood substrates, install underlayment and cover with slip sheet.
- C. Expansion Provisions: Provide for thermal expansion of exposed flashing and trim.
1. Space movement joints at maximum of **10 feet (3 m)** with no joints within **24 inches (600 mm)** of corner or intersection.
 2. Form expansion joints of intermeshing hooked flanges, not less than **1 inch (25 mm)** deep, filled with sealant concealed within joints.
- D. Fasteners: Use fastener sizes that penetrate substrate not less than recommended by fastener manufacturer to achieve maximum pull-out resistance.
- E. Conceal fasteners and expansion provisions where possible in exposed work and locate to minimize possibility of leakage. Cover and seal fasteners and anchors as required for a tight installation.
- F. Seal joints as required for watertight construction.
1. Use sealant-filled joints unless otherwise indicated.
 - a. Embed hooked flanges of joint members not less than **1 inch (25 mm)** into sealant.
 - b. Form joints to completely conceal sealant.
 - c. When ambient temperature at time of installation is between **40 and 70 deg F (4 and 21 deg C)**, set joint members for 50 percent movement each way.
 - d. Adjust setting proportionately for installation at higher ambient temperatures.
 - 1) Do not install sealant-type joints at temperatures below **40 deg F (4 deg C)**.
 2. Prepare joints and apply sealants to comply with requirements in Section 079200 "Joint Sealants."

31.4 INSTALLATION OF ROOF-DRAINAGE SYSTEM

- A. Install sheet metal roof-drainage items to produce complete roof-drainage system in accordance with cited sheet metal standard unless otherwise indicated. Coordinate installation of roof perimeter flashing with installation of roof-drainage system.

B. Hanging Gutters:

1. Join sections with riveted and soldered joints.
2. Provide for thermal expansion.
3. Attach gutters at eave or fascia to firmly anchor them in position.
4. Provide end closures and seal watertight with sealant.
5. Slope to downspouts.
6. Fasten gutter spacers to front and back of gutter.
7. Anchor back of gutter that extends onto roof deck with cleats spaced not more than **24 inches (600 mm)** apart.
8. Anchor gutter with gutter brackets and straps spaced not more than **24 inches (600 mm)** apart to roof deck unless otherwise indicated, and loosely lock to front gutter bead.
9. Install gutter with expansion joints at locations indicated on Drawings, but not exceeding, **50 feet (15.2 m)** apart. Install expansion-joint caps.
10. Install continuous gutter screens on gutters with noncorrosive fasteners, hinged to swing open for cleaning gutters.

C. Downspouts:

1. Join sections with **1-1/2-inch (38-mm)** telescoping joints.
2. Provide hangers with fasteners designed to hold downspouts securely to walls.
3. Locate hangers at top and bottom and at approximately **60 inches (1500 mm)** o.c.
4. Connect downspouts to underground drainage system.

D. Expansion-Joint Covers: Install expansion-joint covers at locations and of configuration indicated on Drawings. Lap joints minimum of **4 inches (100 mm)** in direction of water flow.

31.5 INSTALLATION OF ROOF FLASHINGS

A. Install sheet metal flashing and trim to comply with performance requirements, sheet metal manufacturer's written installation instructions, and cited sheet metal standard.

1. Provide concealed fasteners where possible, and set units true to line, levels, and slopes.
2. Install work with laps, joints, and seams that are permanently watertight and weather resistant.

B. Roof Edge Flashing:

1. Install roof edge flashings in accordance with ANSI/SPRI/FM 4435/ES-1.

C. Pipe or Post Counterflashing: Install counterflashing umbrella with close-fitting collar with top edge flared for elastomeric sealant, extending minimum of **4 inches (100 mm)** over base flashing. Install stainless steel draw band and tighten.

D. Counterflashing: Coordinate installation of counterflashing with installation of base flashing.

1. Insert counterflashing in reglets or receivers and fit tightly to base flashing.
2. Extend counterflashing **4 inches (100 mm)** over base flashing.
3. Lap counterflashing joints minimum of **4 inches (100 mm)**.
4. Secure in waterproof manner by means of snap-in installation and sealant or lead wedges and sealant unless otherwise indicated.

- E. Roof-Penetration Flashing: Coordinate installation of roof-penetration flashing with installation of roofing and other items penetrating roof. Seal with butyl sealant and clamp flashing to pipes that penetrate roof.

31.6 INSTALLATION OF MISCELLANEOUS FLASHING

A. Equipment Support Flashing:

1. Coordinate installation of equipment support flashing with installation of roofing and equipment.
2. Weld or seal flashing with elastomeric sealant to equipment support member.

31.7 INSTALLATION TOLERANCES

- A. Installation Tolerances: Shim and align sheet metal flashing and trim within installed tolerance of **1/4 inch in 20 feet (6 mm in 6 m)** on slope and location lines indicated on Drawings and within **1/8-inch (3-mm)** offset of adjoining faces and of alignment of matching profiles.

31.8 CLEANING

- A. Clean exposed metal surfaces of substances that interfere with uniform oxidation and weathering.
- B. Clean and neutralize flux materials. Clean off excess solder.
- C. Clean off excess sealants.

31.9 PROTECTION

- A. Remove temporary protective coverings and strippable films as sheet metal flashing and trim are installed unless otherwise indicated in manufacturer's written installation instructions.
- B. On completion of sheet metal flashing and trim installation, remove unused materials and clean finished surfaces as recommended in writing by sheet metal flashing and trim manufacturer.
- C. Maintain sheet metal flashing and trim in clean condition during construction.
- D. Replace sheet metal flashing and trim that have been damaged or that have deteriorated beyond successful repair by finish touchup or similar minor repair procedures, as determined by Engineer.

END OF SECTION 07 62 00

SECTION 079200

JOINT SEALANTS

PART 32 - GENERAL

32.1 RELATED DOCUMENTS

- A. Drawings and general provisions of the Contract - Standard Specifications for Public Works Construction 'The GREENBOOK' and City Supplement 'The WHITEBOOK', latest editions, including Supplemental Supplementary Provisions (SSPs), apply to this Section.

32.2 SUMMARY

- A. Section Includes:
 - 1. Silicone joint sealants.
 - 2. Nonstaining silicone joint sealants.
 - 3. Urethane joint sealants.
 - 4. Mildew-resistant joint sealants.
 - 5. Butyl joint sealants.
 - 6. Latex joint sealants.

32.3 PREINSTALLATION MEETINGS

- A. Preinstallation Conference: Conduct conference at Project site.

32.4 ACTION SUBMITTALS

- A. Product Data: For each joint-sealant product.
- B. Samples for Initial Selection: Manufacturer's color charts consisting of strips of cured sealants showing the full range of colors available for each product exposed to view.
- C. Samples for Verification: For each kind and color of joint sealant required, provide Samples with joint sealants in **1/2-inch- (13-mm-)** wide joints formed between two **6-inch- (150-mm-)** long strips of material matching the appearance of exposed surfaces adjacent to joint sealants.
- D. Joint-Sealant Schedule: Include the following information:
 - 1. Joint-sealant application, joint location, and designation.
 - 2. Joint-sealant manufacturer and product name.
 - 3. Joint-sealant formulation.
 - 4. Joint-sealant color.

32.5 INFORMATIONAL SUBMITTALS

- A. Qualification Data: For qualified testing agency.
- B. Product Test Reports: For each kind of joint sealant, for tests performed by manufacturer and witnessed by a qualified testing agency, or a qualified testing agency.
- C. Preconstruction Laboratory Test Schedule: Include the following information for each joint sealant and substrate material to be tested:
 - 1. Joint-sealant location and designation.
 - 2. Manufacturer and product name.
 - 3. Type of substrate material.
 - 4. Proposed test.
 - 5. Number of samples required.
- D. Preconstruction Field-Adhesion-Test Reports: Indicate which sealants and joint preparation methods resulted in optimum adhesion to joint substrates based on testing specified in "Preconstruction Testing" Article.
- E. Field-Adhesion-Test Reports: For each sealant application tested.
- F. Sample Warranties: For special warranties.

32.6 QUALITY ASSURANCE

- A. Installer Qualifications: An authorized representative who is trained and approved by manufacturer.
- B. Product Testing: Test joint sealants using a qualified testing agency.
 - 1. Testing Agency Qualifications: Qualified according to ASTM C 1021 to conduct the testing indicated.
- C. Mockups: Install sealant in mockups of assemblies specified in other Sections that are indicated to receive joint sealants specified in this Section. Use materials and installation methods specified in this Section.

32.7 PRECONSTRUCTION TESTING

- A. Preconstruction Field-Adhesion Testing: Before installing sealants, field test their adhesion to Project joint substrates as follows:
 - 1. Locate test joints where indicated on Project or, if not indicated, as directed by Engineer.
 - 2. Conduct field tests for each kind of sealant and joint substrate.
 - 3. Notify Engineer seven days in advance of dates and times when test joints will be erected.
 - 4. Arrange for tests to take place with joint-sealant manufacturer's technical representative present.

- a. Test Method: Test joint sealants according to Method A, Field-Applied Sealant Joint Hand Pull Tab, in Appendix X1.1 in ASTM C 1193 or Method A, Tail Procedure, in ASTM C 1521.
 - 1) For joints with dissimilar substrates, verify adhesion to each substrate separately; extend cut along one side, verifying adhesion to opposite side. Repeat procedure for opposite side.
- 5. Report whether sealant failed to adhere to joint substrates or tore cohesively. Include data on pull distance used to test each kind of product and joint substrate. For sealants that fail adhesively, retest until satisfactory adhesion is obtained.
- 6. Evaluation of Preconstruction Field-Adhesion-Test Results: Sealants not evidencing adhesive failure from testing, in absence of other indications of noncompliance with requirements, will be considered satisfactory. Do not use sealants that fail to adhere to joint substrates during testing.

32.8 FIELD CONDITIONS

- A. Do not proceed with installation of joint sealants under the following conditions:
 - 1. When ambient and substrate temperature conditions are outside limits permitted by joint-sealant manufacturer or are below 40 deg F (5 deg C).
 - 2. When joint substrates are wet.
 - 3. Where joint widths are less than those allowed by joint-sealant manufacturer for applications indicated.
 - 4. Where contaminants capable of interfering with adhesion have not yet been removed from joint substrates.

32.9 WARRANTY

- A. Special Installer's Warranty: Installer agrees to repair or replace joint sealants that do not comply with performance and other requirements specified in this Section within specified warranty period.
 - 1. Warranty Period: Two years from date of Substantial Completion.
- B. Special Manufacturer's Warranty: Manufacturer agrees to furnish joint sealants to repair or replace those joint sealants that do not comply with performance and other requirements specified in this Section within specified warranty period.
 - 1. Warranty Period: Five years from date of Substantial Completion.
- C. Special warranties specified in this article exclude deterioration or failure of joint sealants from the following:
 - 1. Movement of the structure caused by stresses on the sealant exceeding sealant manufacturer's written specifications for sealant elongation and compression.
 - 2. Disintegration of joint substrates from causes exceeding design specifications.
 - 3. Mechanical damage caused by individuals, tools, or other outside agents.
 - 4. Changes in sealant appearance caused by accumulation of dirt or other atmospheric contaminants.

PART 33 - PRODUCTS

33.1 JOINT SEALANTS, GENERAL

- A. Compatibility: Provide joint sealants, backings, and other related materials that are compatible with one another and with joint substrates under conditions of service and application, as demonstrated by joint-sealant manufacturer, based on testing and field experience.
- B. Colors of Exposed Joint Sealants: As selected by Engineer from manufacturer's full range.

33.2 SILICONE JOINT SEALANTS

- A. Silicone, S, P, 25, T, NT: Single-component, pourable, plus 25 percent and minus 25 percent movement capability, traffic- and nontraffic-use, neutral-curing silicone joint sealant; ASTM C 920, Type S, Grade P, Class 25, Uses T and NT.
- B. Silicone, M, P, 100/50, T, NT: Multicomponent, pourable, plus 100 percent and minus 50 percent movement capability, traffic- and nontraffic-use, neutral-curing silicone joint sealant; ASTM C 920, Type M, Grade P, Class 100/50, Uses T and NT.

33.3 NONSTAINING SILICONE JOINT SEALANTS

- A. Nonstaining Joint Sealants: No staining of substrates when tested according to ASTM C 1248.
- B. Silicone, Nonstaining, S, NS, 50, NT: Nonstaining, single-component, nonsag, plus 50 percent and minus 50 percent movement capability, nontraffic-use, neutral-curing silicone joint sealant; ASTM C 920, Type S, Grade NS, Class 50, Use NT.

33.4 URETHANE JOINT SEALANTS

- A. Urethane, S, NS, 25, NT: Single-component, nonsag, nontraffic-use, plus 25 percent and minus 25 percent movement capability, urethane joint sealant; ASTM C 920, Type S, Grade NS, Class 25, Use NT.

33.5 MILDEW-RESISTANT JOINT SEALANTS

- A. Mildew-Resistant Joint Sealants: Formulated for prolonged exposure to humidity with fungicide to prevent mold and mildew growth.
- B. Silicone, Mildew Resistant, Acid Curing, S, NS, 25, NT: Mildew-resistant, single-component, nonsag, plus 25 percent and minus 25 percent movement capability, nontraffic-use, acid-curing silicone joint sealant; ASTM C 920, Type S, Grade NS, Class 25, Use NT.

33.6 BUTYL JOINT SEALANTS

- A. Butyl-Rubber-Based Joint Sealants: ASTM C 1311.

33.7 JOINT-SEALANT BACKING

- A. Sealant Backing Material, General: Nonstaining; compatible with joint substrates, sealants, primers, and other joint fillers; and approved for applications indicated by sealant manufacturer based on field experience and laboratory testing.
 - 1. Manufacturers: Subject to compliance with requirements, available manufacturers offering products that may be incorporated into the Work include, but are not limited to, the following:
 - a. Adfast.
 - b. Alcot Plastics Ltd.
 - c. BASF Corporation.
 - d. Construction Foam Products; a division of Nomaco, Inc.
 - e. Approved Equal.
- B. Cylindrical Sealant Backings: ASTM C 1330,
 - 1. Type C (closed-cell material with a surface skin),
 - 2. Type O (open-cell material),
 - 3. Type B (bicellular material with a surface skin),
 - 4. or any of the preceding types, as approved in writing by joint-sealant manufacturer for joint application indicated, and of size and density to control sealant depth and otherwise contribute to producing optimum sealant performance.
- C. Bond-Breaker Tape: Polyethylene tape or other plastic tape recommended by sealant manufacturer for preventing sealant from adhering to rigid, inflexible joint-filler materials or joint surfaces at back of joint. Provide self-adhesive tape where applicable.

33.8 MISCELLANEOUS MATERIALS

- A. Primer: Material recommended by joint-sealant manufacturer where required for adhesion of sealant to joint substrates indicated, as determined from preconstruction joint-sealant-substrate tests and field tests.
- B. Cleaners for Nonporous Surfaces: Chemical cleaners acceptable to manufacturers of sealants and sealant backing materials, free of oily residues or other substances capable of staining or harming joint substrates and adjacent nonporous surfaces in any way, and formulated to promote optimum adhesion of sealants to joint substrates.
- C. Masking Tape: Nonstaining, nonabsorbent material compatible with joint sealants and surfaces adjacent to joints.

PART 34 - EXECUTION

34.1 EXAMINATION

- A. Examine joints indicated to receive joint sealants, with Installer present, for compliance with requirements for joint configuration, installation tolerances, and other conditions affecting performance of the Work.
- B. Proceed with installation only after unsatisfactory conditions have been corrected.

34.2 PREPARATION

- A. Surface Cleaning of Joints: Clean out joints immediately before installing joint sealants to comply with joint-sealant manufacturer's written instructions and the following requirements:
1. Remove all foreign material from joint substrates that could interfere with adhesion of joint sealant, including dust, paints (except for permanent, protective coatings tested and approved for sealant adhesion and compatibility by sealant manufacturer), old joint sealants, oil, grease, waterproofing, water repellents, water, surface dirt, and frost.
 2. Clean porous joint substrate surfaces by brushing, grinding, mechanical abrading, or a combination of these methods to produce a clean, sound substrate capable of developing optimum bond with joint sealants. Remove loose particles remaining after cleaning operations above by vacuuming or blowing out joints with oil-free compressed air. Porous joint substrates include the following:
 - a. Concrete.
 - b. Masonry.
 3. Remove laitance and form-release agents from concrete.
 4. Clean nonporous joint substrate surfaces with chemical cleaners or other means that do not stain, harm substrates, or leave residues capable of interfering with adhesion of joint sealants. Nonporous joint substrates include the following:
 - a. Metal.
 - b. Porcelain enamel.
- B. Joint Priming: Prime joint substrates where recommended by joint-sealant manufacturer or as indicated by preconstruction joint-sealant-substrate tests or prior experience. Apply primer to comply with joint-sealant manufacturer's written instructions. Confine primers to areas of joint-sealant bond; do not allow spillage or migration onto adjoining surfaces.
- C. Masking Tape: Use masking tape where required to prevent contact of sealant or primer with adjoining surfaces that otherwise would be permanently stained or damaged by such contact or by cleaning methods required to remove sealant smears. Remove tape immediately after tooling without disturbing joint seal.

34.3 INSTALLATION OF JOINT SEALANTS

- A. General: Comply with joint-sealant manufacturer's written installation instructions for products and applications indicated, unless more stringent requirements apply.
- B. Sealant Installation Standard: Comply with recommendations in ASTM C 1193 for use of joint sealants as applicable to materials, applications, and conditions indicated.
- C. Install sealant backings of kind indicated to support sealants during application and at position required to produce cross-sectional shapes and depths of installed sealants relative to joint widths that allow optimum sealant movement capability.
1. Do not leave gaps between ends of sealant backings.
 2. Do not stretch, twist, puncture, or tear sealant backings.
 3. Remove absorbent sealant backings that have become wet before sealant application, and replace them with dry materials.

- D. Install bond-breaker tape behind sealants where sealant backings are not used between sealants and backs of joints.
- E. Install sealants using proven techniques that comply with the following and at the same time backings are installed:
 - 1. Place sealants so they directly contact and fully wet joint substrates.
 - 2. Completely fill recesses in each joint configuration.
 - 3. Produce uniform, cross-sectional shapes and depths relative to joint widths that allow optimum sealant movement capability.
- F. Tooling of Nonsag Sealants: Immediately after sealant application and before skinning or curing begins, tool sealants according to requirements specified in subparagraphs below to form smooth, uniform beads of configuration indicated; to eliminate air pockets; and to ensure contact and adhesion of sealant with sides of joint.
 - 1. Remove excess sealant from surfaces adjacent to joints.
 - 2. Use tooling agents that are approved in writing by sealant manufacturer and that do not discolor sealants or adjacent surfaces.
 - 3. Provide concave joint profile per Figure 8A in ASTM C 1193 unless otherwise indicated.
 - 4. Provide flush joint profile at joints between soffit panels according to Figure 8B in ASTM C 1193.
 - a. Use masking tape to protect surfaces adjacent to recessed tooled joints.

34.4 FIELD QUALITY CONTROL

- A. Field-Adhesion Testing: Field test joint-sealant adhesion to joint substrates as follows:
 - 1. Extent of Testing: Test completed and cured sealant joints as follows:
 - a. Perform 4 tests for the first 500 feet of joint length for each kind of sealant and joint substrate.
 - 2. Test Method: Test joint sealants according to Method A, Field-Applied Sealant Joint Hand Pull Tab, in Appendix X1 in ASTM C 1193 or Method A, Tail Procedure, in ASTM C 1521.
 - a. For joints with dissimilar substrates, verify adhesion to each substrate separately; extend cut along one side, verifying adhesion to opposite side. Repeat procedure for opposite side.
 - 3. Inspect tested joints and report on the following:
 - a. Whether sealants filled joint cavities and are free of voids.
 - b. Whether sealant dimensions and configurations comply with specified requirements.
 - c. Whether sealants in joints connected to pulled-out portion failed to adhere to joint substrates or tore cohesively. Include data on pull distance used to test each kind of product and joint substrate. Compare these results to determine if adhesion complies with sealant manufacturer's field-adhesion hand-pull test criteria.

4. Record test results in a field-adhesion-test log. Include dates when sealants were installed, names of persons who installed sealants, test dates, test locations, whether joints were primed, adhesion results and percent elongations, sealant material, sealant configuration, and sealant dimensions.
5. Repair sealants pulled from test area by applying new sealants following same procedures used originally to seal joints. Ensure that original sealant surfaces are clean and that new sealant contacts original sealant.

B. Evaluation of Field-Adhesion-Test Results: Sealants not evidencing adhesive failure from testing or noncompliance with other indicated requirements will be considered satisfactory. Remove sealants that fail to adhere to joint substrates during testing or to comply with other requirements. Retest failed applications until test results prove sealants comply with indicated requirements.

34.5 CLEANING

A. Clean off excess sealant or sealant smears adjacent to joints as the Work progresses by methods and with cleaning materials approved in writing by manufacturers of joint sealants and of products in which joints occur.

34.6 PROTECTION

A. Protect joint sealants during and after curing period from contact with contaminating substances and from damage resulting from construction operations or other causes so sealants are without deterioration or damage at time of Substantial Completion. If, despite such protection, damage or deterioration occurs, cut out, remove, and repair damaged or deteriorated joint sealants immediately so installations with repaired areas are indistinguishable from original work.

34.7 JOINT-SEALANT SCHEDULE

A. Joint-Sealant Application: Exterior joints in vertical surfaces and horizontal nontraffic surfaces <JS-1>.

1. Joint Locations:

- a. Construction joints in cast-in-place concrete.
- b. Joints between plant-precast architectural concrete units.
- c. Control and expansion joints in unit masonry.
- d. Joints in dimension stone cladding.
- e. Joints in glass unit masonry assemblies.
- f. Joints in exterior insulation and finish systems.
- g. Joints between metal panels.
- h. Joints between different materials listed above.
- i. Perimeter joints between materials listed above and frames of doors, louvers and screening panels.
- j. Control and expansion joints in ceilings, soffits, and other overhead surfaces.
- k. Other joints as indicated on Drawings.

2. Joint Sealant: Silicone, nonstaining, S, NS, 50, NT.

3. Joint-Sealant Color: As selected by Engineer from manufacturer's full range of colors.

- B. Joint-Sealant Application: Interior joints in horizontal traffic surfaces <JS-2>.
1. Joint Locations:
 - a. Isolation joints in cast-in-place concrete slabs.
 - b. Other joints as indicated on Drawings.
 2. Joint Sealant: Urethane, S, P, 25, T, NT.
 3. Joint-Sealant Color: As selected by Engineer from manufacturer's full range of colors.
- C. Joint-Sealant Application: Interior joints in vertical surfaces and horizontal nontraffic surfaces <JS-3>.
1. Joint Locations:
 - a. Control and expansion joints on exposed interior surfaces of exterior walls.
 - b. Tile control and expansion joints.
 - c. Vertical joints on exposed surfaces of unit masonry, concrete, walls and partitions.
 - d. Other joints as indicated on Drawings.
 2. Joint Sealant: Urethane, S, NS, 25, NT.
 3. Joint-Sealant Color: As selected by Engineer from manufacturer's full range of colors.
- D. Joint-Sealant Application: Mildew-resistant interior joints in vertical surfaces and horizontal nontraffic surfaces <JS-4>.
1. Joint Locations:
 - a. Joints between plumbing fixtures and adjoining walls, floors, and counters.
 - b. Tile control and expansion joints where indicated.
 - c. Other joints as indicated on Drawings.
 2. Joint Sealant: Silicone, mildew resistant, acid curing, S, NS, 25, NT.
 3. Joint-Sealant Color: As selected by Engineer from manufacturer's full range of colors.
- E. Joint-Sealant Application: Concealed mastics <JS-5>.
1. Joint Locations:
 - a. Aluminum thresholds.
 - b. Sill plates.
 - c. Other joints as indicated on Drawings.
 2. Joint Sealant: Butyl-rubber based.
 3. Joint-Sealant Color: As selected by Engineer from manufacturer's full range of colors.

END OF SECTION 079200

SECTION 081113

HOLLOW METAL DOORS AND FRAMES

PART 35 - GENERAL

35.1 RELATED DOCUMENTS

- A. Drawings and general provisions of the Contract - Standard Specifications for Public Works Construction 'The GREENBOOK' and City Supplement 'The WHITEBOOK', latest editions, including Supplemental Supplementary Provisions (SSPs), apply to this Section.

35.2 SUMMARY

- A. Section includes:
 - 1. Interior standard steel doors and frames.
 - 2. Exterior standard steel doors and frames.
- B. Related Requirements:
 - 1. Section 087100 "Door Hardware" for door hardware for hollow-metal doors.

35.3 DEFINITIONS

- A. Minimum Thickness: Minimum thickness of base metal without coatings according to NAAMM-HMMA 803 or SDI A250.8.

35.4 COORDINATION

- A. Coordinate anchorage installation for hollow-metal frames. Furnish setting drawings, templates, and directions for installing anchorages, including sleeves, concrete inserts, anchor bolts, and items with integral anchors. Deliver such items to Project site in time for installation.
- B. Coordinate requirements for installation of door hardware, electrified door hardware, and access control and security systems.

35.5 ACTION SUBMITTALS

- A. Product Data: For each type of product.
 - 1. Include construction details, material descriptions, core descriptions, and finishes.
- B. Shop Drawings: Include the following:
 - 1. Elevations of each door type.
 - 2. Details of doors, including vertical- and horizontal-edge details and metal thicknesses.

3. Frame details for each frame type, including dimensioned profiles and metal thicknesses.
 4. Locations of reinforcement and preparations for hardware.
 5. Details of each different wall opening condition.
 6. Details of anchorages, joints, field splices, and connections.
 7. Details of accessories.
- C. Product Schedule: For hollow-metal doors and frames, prepared by or under the supervision of supplier, using same reference numbers for details and openings as those on Drawings. Coordinate with final door hardware schedule.

35.6 DELIVERY, STORAGE, AND HANDLING

- A. Deliver hollow-metal doors and frames palletized, packaged, or crated to provide protection during transit and Project-site storage. Do not use nonvented plastic.
 1. Provide additional protection to prevent damage to factory-finished units.
- B. Deliver welded frames with two removable spreader bars across bottom of frames, tack welded to jambs and mullions.
- C. Store hollow-metal doors and frames vertically under cover at Project site with head up. Place on minimum **4-inch- (102-mm-)** high wood blocking. Provide minimum **1/4-inch (6-mm)** space between each stacked door to permit air circulation.

PART 36 - PRODUCTS

36.1 EXTERIOR STANDARD STEEL DOORS AND FRAMES

- A. Construct hollow-metal doors and frames to comply with standards indicated for materials, fabrication, hardware locations, hardware reinforcement, tolerances, and clearances, and as specified.
- B. Extra-Heavy-Duty Doors and Frames: SDI A250.8, Level 3; SDI A250.4, Level A. Locations include all doors accessing Storage Rooms including Doors 103, 104, 203 and 204.
 1. Doors:
 - a. Type: As indicated in the Door and Frame Schedule.
 - b. Thickness: **1-3/4 inches (44.5 mm)**.
 - c. Face: Metallic-coated steel sheet, minimum thickness of **0.059 inch (1.52 mm)**, with minimum **A60 (ZF180)** coating.
 - d. Edge Construction: Model 2, Seamless.
 - e. Edge Bevel: Provide manufacturer's standard beveled or square edges.
 - f. Top Edge Closures: Close top edges of doors with flush closures of same material as face sheets. Seal joints against water penetration.
 - g. Bottom Edges: Close bottom edges of doors with end closures or channels of same material as face sheets. Provide weep-hole openings in bottoms of exterior doors to permit moisture to escape.
 - h. Core: Vertical steel stiffener.

2. Frames:
 - a. Materials: Metallic-coated steel sheet, minimum thickness of 0.074 inch (1.9 mm), with minimum A60 (ZF180) coating.
 - b. Construction: Full profile welded.
 - c. Provide 4" high head component as indicated, to coordinate overall frame height with masonry coursing.
3. Exposed Finish: Prime.

36.2 MATERIALS

- A. Cold-Rolled Steel Sheet: ASTM A 1008/A 1008M, Commercial Steel (CS), Type B; suitable for exposed applications.
- B. Hot-Rolled Steel Sheet: ASTM A 1011/A 1011M, Commercial Steel (CS), Type B; free of scale, pitting, or surface defects; pickled and oiled.
- C. Metallic-Coated Steel Sheet: ASTM A 653/A 653M, Commercial Steel (CS), Type B.
- D. Inserts, Bolts, and Fasteners: Hot-dip galvanized according to ASTM A 153/A 153M.
- E. Power-Actuated Fasteners in Concrete: Fastener system of type suitable for application indicated, fabricated from corrosion-resistant materials, with clips or other accessory devices for attaching hollow-metal frames of type indicated.

36.3 FABRICATION

- A. Door Astragals: Provide overlapping astragal on one leaf of pairs of doors where required by NFPA 80 for fire-performance rating or where indicated. Extend minimum 3/4 inch (19 mm) beyond edge of door on which astragal is mounted or as required to comply with published listing of qualified testing agency.
- B. Hollow-Metal Frames: Fabricate in one piece except where handling and shipping limitations require multiple sections. Where frames are fabricated in sections, provide alignment plates or angles at each joint, fabricated of metal of same or greater thickness as frames.
 1. Frames: Provide closed tubular members with no visible face seams or joints, fabricated from same material as door frame. Fasten members at crossings and to jambs by welding.
 2. Provide countersunk, flat- or oval-head exposed screws and bolts for exposed fasteners unless otherwise indicated.
 3. Door Silencers: Except on weather-stripped frames, drill stops to receive door silencers as follows. Keep holes clear during construction.
 - a. Single-Door Frames: Drill stop in strike jamb to receive three door silencers.
 - b. Double-Door Frames: Drill stop in head jamb to receive two door silencers.
 4. Terminated Stops: Terminate stops 6 inches (152 mm) above finish floor with a 45-degree angle cut, and close open end of stop with steel sheet closure. Cover opening

in extension of frame with welded-steel filler plate, with welds ground smooth and flush with frame.

- C. Hardware Preparation: Factory prepare hollow-metal doors and frames to receive templated mortised hardware, and electrical wiring; include cutouts, reinforcement, mortising, drilling, and tapping according to SDI A250.6, the Door Hardware Schedule, and templates.
 - 1. Reinforce doors and frames to receive nontemplated, mortised, and surface-mounted door hardware.
 - 2. Comply with BHMA A156.115 for preparing hollow-metal doors and frames for hardware.

36.4 STEEL FINISHES

- A. Prime Finish: Clean, pretreat, and apply manufacturer's standard primer.
 - 1. Shop Primer: Manufacturer's standard, fast-curing, lead- and chromate-free primer complying with SDI A250.10; recommended by primer manufacturer for substrate; compatible with substrate and field-applied coatings despite prolonged exposure.

PART 37 - EXECUTION

37.1 PREPARATION

- A. Remove welded-in shipping spreaders installed at factory. Restore exposed finish by grinding, filling, and dressing, as required to make repaired area smooth, flush, and invisible on exposed faces. Touch up factory-applied finishes where spreaders are removed.
- B. Drill and tap doors and frames to receive nontemplated, mortised, and surface-mounted door hardware.

37.2 INSTALLATION

- A. General: Install hollow-metal doors and frames plumb, rigid, properly aligned, and securely fastened in place. Comply with approved Shop Drawings and with manufacturer's written instructions.
- B. Hollow-Metal Frames: Comply with SDI A250.11.
 - 1. Set frames accurately in position; plumbed, aligned, and braced securely until permanent anchors are set. After wall construction is complete, remove temporary braces without damage to completed Work.
 - a. Where frames are fabricated in sections, field splice at approved locations by welding face joint continuously; grind, fill, dress, and make splice smooth, flush, and invisible on exposed faces. Touch-up finishes.
 - b. Install frames with removable stops located on secure side of opening.
 - 2. Floor Anchors: Secure with postinstalled expansion anchors.

3. In-Place Concrete or Masonry Construction: Secure frames in place with postinstalled expansion anchors. Countersink anchors, and fill and make smooth, flush, and invisible on exposed faces.
 4. Installation Tolerances: Adjust hollow-metal frames to the following tolerances:
 - a. Squareness: Plus or minus **1/16 inch (1.6 mm)**, measured at door rabbet on a line 90 degrees from jamb perpendicular to frame head.
 - b. Alignment: Plus or minus **1/16 inch (1.6 mm)**, measured at jambs on a horizontal line parallel to plane of wall.
 - c. Twist: Plus or minus **1/16 inch (1.6 mm)**, measured at opposite face corners of jambs on parallel lines, and perpendicular to plane of wall.
 - d. Plumbness: Plus or minus **1/16 inch (1.6 mm)**, measured at jambs at floor.
- C. Hollow-Metal Doors: Fit and adjust hollow-metal doors accurately in frames, within clearances specified below.
1. Non-Fire-Rated Steel Doors: Comply with SDI A250.8.

37.3 CLEANING AND TOUCHUP

- A. Prime-Coat Touchup: Immediately after erection, sand smooth rusted or damaged areas of prime coat and apply touchup of compatible air-drying, rust-inhibitive primer.
- B. Metallic-Coated Surface Touchup: Clean abraded areas and repair with galvanizing repair paint according to manufacturer's written instructions.

END OF SECTION 081113

SECTION 083313
COILING COUNTER DOORS

PART 38 - GENERAL

38.1 RELATED DOCUMENTS

- A. Drawings and general provisions of the Contract - Standard Specifications for Public Works Construction 'The GREENBOOK' and City Supplement 'The WHITEBOOK', latest editions, including Supplemental Supplementary Provisions (SSPs), apply to this Section.

38.2 SUMMARY

- A. Section Includes:
 - 1. Counter doors.
- B. Related Requirements:
 - 1. Section 055000 "Metal Fabrications" for door-opening framing and corner guards.

38.3 ACTION SUBMITTALS

- A. Product Data: For each type and size of coiling counter door and accessory.
 - 1. Include construction details, material descriptions, dimensions of individual components, profiles for slats, and finishes.
 - 2. Include rated capacities, operating characteristics, electrical characteristics, and furnished accessories.
- B. Shop Drawings: For each installation and for special components not dimensioned or detailed in manufacturer's product data.
 - 1. Include plans, elevations, sections, and mounting details.
 - 2. Include details of equipment assemblies, and indicate dimensions, required clearances, method of field assembly, components, and location and size of each field connection.
 - 3. Include points of attachment and their corresponding static and dynamic loads imposed on structure.
 - 4. Show locations of controls, locking devices, and other accessories.
- C. Samples for Verification: For each type of exposed finish on the following components, in manufacturer's standard sizes:
 - 1. Curtain slats.
 - 2. Bottom bar.
 - 3. Guides.
 - 4. Brackets.
 - 5. Hood.

6. Locking device(s).
7. Include similar Samples of accessories involving color selection.

38.4 INFORMATIONAL SUBMITTALS

- A. Qualification Data: For Installer.

38.5 CLOSEOUT SUBMITTALS

- A. Maintenance Data: For coiling counter doors to include in maintenance manuals.

38.6 QUALITY ASSURANCE

- A. Installer Qualifications: An entity that employs installers and supervisors who are trained and approved by manufacturer for both installation and maintenance of units required for this Project.

38.7 REGULATORY REQUIREMENTS

- A. Pass-through Windows:
 1. Pass-through windows of sales/service counter shall comply with the reach and access requirements of CBC Sections 11B-227.3, 11B-305, 11B-306, 11B-308, 11B-309, and 11B-904.4.

PART 39 - PRODUCTS

39.1 MANUFACTURERS

- A. Source Limitations: Obtain coiling counter doors from single source from single manufacturer.
 1. Obtain operators and controls from coiling counter door manufacturer.

39.2 COUNTER DOOR ASSEMBLY <Doors 13, 14, 15 per Schedule>

- A. Counter Door: Coiling counter door formed with curtain of interlocking metal slats.
 1. **Manufacturers:** Subject to compliance with requirements, [provide products by the following] [provide products by one of the following] [available manufacturers offering products that may be incorporated into the Work include, but are not limited to, the following]:
 - a. [Alpine Overhead Doors, Inc.](#)
 - b. [Cookson Company.](#)
 - c. [McKeon Rolling Steel Door Company, Inc.](#)

- B. Operation Cycles: Door components and operators capable of operating for not less than 100,000 cycles. One operation cycle is complete when a door is opened from the closed position to the fully open position and returned to the closed position.
 - 1. Include tamperproof cycle counter.
- C. Door Curtain Material: Stainless steel.
- D. Door Curtain Slats: Flat profile slats of 1-1/2-inch (38-mm) center-to-center height.
- E. Bottom Bar: Manufacturer's standard continuous channel or tubular shape, fabricated stainless steel and finished to match door.
- F. Curtain Jamb Guides: Stainless steel with exposed finish matching curtain slats. Provide continuous integral wear strips to prevent metal-to-metal contact and to minimize operational noise.
- G. Hood: Match curtain material and finish.
 - 1. Shape: Round.
 - 2. Mounting: Face of wall.
- H. Sill Configuration: No sill.
- I. Locking Devices: Equip door with locking device assembly.
 - 1. Locking Device Assembly: Cremona-type, both jamb sides locking bars, operable from inside only, with cylinder.
- J. Manual Door Operator: Manufacturer's standard crank operator.
 - 1. Provide operator with manufacturer's standard removable operating arm.
- K. Curtain Accessories: Equip door with weatherseals.
- L. Door Finish:
 - 1. Stainless-Steel Finish: No. 4 (polished directional satin).
 - 2. Interior Curtain-Slat Facing: Match finish of exterior curtain-slat face.

39.3 DOOR CURTAIN MATERIALS AND CONSTRUCTION

- A. Door Curtains: Fabricate coiling counter door curtain of interlocking metal slats in a continuous length for width of door without splices. Unless otherwise indicated, provide slats of thickness and mechanical properties recommended by door manufacturer for performance, size, and type of door indicated, and as follows:
 - 1. Stainless-Steel Door Curtain Slats: ASTM A 666, Type 304; sheet thickness of 0.025 inch (0.64 mm); and as required.
 - 2. Metal Interior Curtain-Slat Facing: Match metal of exterior curtain-slat face.
- B. Curtain Jamb Guides: Manufacturer's standard angles or channels and angles of same material and finish as curtain slats unless otherwise indicated, with sufficient depth and strength to retain curtain, to allow curtain to operate smoothly, and to withstand loading. Slot bolt holes for guide adjustment. Provide removable stops on guides to prevent overtravel of curtain.

39.4 HOODS

- A. General: Form sheet metal hood to entirely enclose coiled curtain and operating mechanism at opening head. Contour to fit end brackets to which hood is attached. Roll and reinforce top and bottom edges for stiffness. Form closed ends for surface-mounted hoods and fascia for any portion of between-jamb mounting that projects beyond wall face. Equip hood with intermediate support brackets as required to prevent sagging.
 1. Stainless Steel: **0.025-inch- (0.64-mm-)** thick, stainless-steel sheet, Type 304, complying with ASTM A 666.

39.5 LOCKING DEVICES

- A. Locking Device Assembly: Fabricate with cylinder lock, spring-loaded dead bolt, operating handle, cam plate, and adjustable locking bars to engage through slots in tracks.
 1. Lock Cylinders: As specified in Section 087100 "Door Hardware" and keyed to building keying system.

39.6 CURTAIN ACCESSORIES

- A. Weatherseals: Equip door with weather-stripping gaskets fitted to entire perimeter of door for air-resistant installation unless otherwise indicated.
 1. At door head, use **1/8-inch- (3-mm-)** thick, replaceable, continuous-sheet baffle secured to inside of hood or field-installed on the header.
 2. At door jambs, use replaceable, adjustable, continuous, flexible, **1/8-inch- (3-mm-)** thick seals of flexible vinyl, rubber, or neoprene.
- B. Astragal: Equip each door bottom bar with a replaceable, adjustable, continuous, compressible gasket of flexible vinyl, rubber, or neoprene as a cushion bumper.

39.7 COUNTER DOOR ACCESSORIES

- A. Integral Metal Sill: Fabricate sills as integral part of frame assembly of Type 304 stainless steel in manufacturer's standard thickness with No. 4 finish.

39.8 COUNTERBALANCE MECHANISM

- A. General: Counterbalance doors by means of manufacturer's standard mechanism with an adjustable-tension, steel helical torsion spring mounted around a steel shaft and contained in a spring barrel connected to top of curtain with barrel rings. Use grease-sealed bearings or self-lubricating graphite bearings for rotating members.
- B. Counterbalance Barrel: Fabricate spring barrel of manufacturer's standard hot-formed, structural-quality, seamless carbon-steel pipe, of sufficient diameter and wall thickness to support rolled-up curtain without distortion of slats and to limit barrel deflection to not more than **0.03 in./ft. (2.5 mm/m)** of span under full load.
- C. Counterbalance Spring: One or more oil-tempered, heat-treated steel helical torsion springs. Size springs to counterbalance weight of curtain, with uniform adjustment

accessible from outside barrel. Secure ends of springs to barrel and shaft with cast-steel barrel plugs.

- D. Torsion Rod for Counterbalance Shaft: Fabricate of manufacturer's standard cold-rolled steel, sized to hold fixed spring ends and carry torsional load.
- E. Brackets: Manufacturer's standard mounting brackets of either cast iron or cold-rolled steel plate.

39.9 MANUAL DOOR OPERATORS

- A. General: Equip door with manual door operator by door manufacturer.
- B. Crank Operator: Consisting of crank and crank gearbox, steel crank drive shaft, and gear-reduction unit, of type indicated. Size gears to require not more than 5-lbf (22-N) force to turn crank. Fabricate gearbox to be oiltight and to completely enclose operating mechanism. Provide manufacturer's standard crank-locking device.

39.10 GENERAL FINISH REQUIREMENTS

- A. Comply with NAAMM/NOMMA 500 for recommendations for applying and designating finishes.
- B. Appearance of Finished Work: Noticeable variations in same piece are not acceptable. Variations in appearance of adjoining components are acceptable if they are within the range of approved Samples and are assembled or installed to minimize contrast.

39.11 STAINLESS-STEEL FINISHES

- A. Surface Preparation: Remove tool and die marks and stretch lines, or blend into finish.
- B. Polished Finishes: Grind and polish surfaces to produce uniform finish, free of cross scratches.
 1. Run grain of directional finishes with long dimension of each piece.
 2. When polishing is completed, passivate and rinse surfaces. Remove embedded foreign matter and leave surfaces chemically clean.
 3. Directional Satin Finish: No. 4.

PART 40 - EXECUTION

40.1 EXAMINATION

- A. Examine substrates areas and conditions, with Installer present, for compliance with requirements for substrate construction and other conditions affecting performance of the Work.
- B. Examine locations of electrical connections.

- C. Proceed with installation only after unsatisfactory conditions have been corrected.

40.2 INSTALLATION

- A. Install coiling counter doors and operating equipment complete with necessary hardware, anchors, inserts, hangers, and equipment supports; according to manufacturer's written instructions and as specified.
- B. Install coiling counter doors, hoods, controls, and operators at the mounting locations indicated for each door.

40.3 STARTUP SERVICE

- A. Engage a factory-authorized service representative to perform startup service.
 - 1. Complete installation and startup checks according to manufacturer's written instructions.
 - 2. Test and adjust controls and safety devices. Replace damaged and malfunctioning controls and equipment.

40.4 ADJUSTING

- A. Adjust hardware and moving parts to function smoothly so that doors operate easily, free of warp, twist, or distortion.
- B. Lubricate bearings and sliding parts as recommended by manufacturer.

40.5 DEMONSTRATION

- A. Engage a factory-authorized service representative to train Owner's maintenance personnel to adjust, operate, and maintain coiling counter doors.

END OF SECTION 083313

SECTION 087100
DOOR HARDWARE

PART 41 - GENERAL

41.1 RELATED DOCUMENTS

- A. Drawings and general provisions of the Contract - Standard Specifications for Public Works Construction 'The GREENBOOK' and City Supplement 'The WHITEBOOK', latest editions, including Supplemental Supplementary Provisions (SSPs), apply to this Section.

41.2 SUMMARY

- A. Section Includes:

- 1. Mechanical door hardware for the following:
 - a. Swinging doors.
- 2. Cylinders for door hardware specified in other Sections.

- B. Intent of Hardware Groups

- 1. Should items of hardware not definitely specified be required for completion of the Work, furnish such items of type and quality comparable to adjacent hardware and appropriate for service required.
- 2. Where items of hardware aren't definitely or correctly specified, and are required for completion of the Work, a written statement of such omission, error, or other discrepancy to be submitted to Architect, prior to date specified for receipt of bids for clarification by addendum; or, furnish such items in the type and quality established by this specification, and appropriate to the service intended.

41.3 COORDINATION

- A. Installation Templates: Distribute for doors, frames, and other work specified to be factory prepared. Check Shop Drawings of other work to confirm that adequate provisions are made for locating and installing door hardware to comply with indicated requirements.
- B. Security: Coordinate installation of door hardware, keying, and access control with Owner's security consultant.
- C. Electrical System Roughing-In: Coordinate layout and installation of electrified door hardware with connections to power supplies and building safety and security systems.
- D. Existing Openings: Where hardware components are scheduled for application to existing construction or where modifications to existing door hardware are required, field verify existing conditions and coordinate installation of door hardware to suit opening conditions and to provide proper door operation.

41.4 PREINSTALLATION MEETINGS

- A. Preinstallation Conference: Conduct conference at Project site.
 - 1. Conference participants shall include Installer's Architectural Hardware Consultant, City Facilities Maintenance, City Public Works Project Manager, City Field Division Resident Engineer (RE), Architect.
- B. Keying Conference: Conduct conference at Project site.
 - 1. Conference participants shall include Installer's Architectural Hardware Consultant, City Field Division Resident Engineer (RE) and representative from City Lock Shop.
 - 2. Incorporate conference decisions into keying schedule after reviewing door hardware keying system including, but not limited to, the following:
 - a. Flow of traffic and degree of security required.
 - b. Preliminary key system schematic diagram.
 - c. Requirements for key control system.
 - d. Requirements for access control.
 - e. Address for delivery of keys.
 - f. Review of the above, and any other CITY SPECIFIC keying requirements as indicated by Facilities Maintenance and City Lock Shop representative.

41.5 ACTION SUBMITTALS

- A. Product Data: For each type of product.
 - 1. Include construction details, material descriptions, dimensions of individual components and profiles, and finishes.
- B. Samples for Verification: For each type of exposed product, in each finish specified.
 - 1. Sample Size: Full-size units or minimum 2-by-4-inch (51-by-102-mm) Samples for sheet and 4-inch (102-mm) long Samples for other products.
 - a. Full-size Samples will be returned to Contractor. Units that are acceptable and remain undamaged through submittal, review, and field comparison process may, after final check of operation, be incorporated into the Work, within limitations of keying requirements.
 - 2. Tag Samples with full product description to coordinate Samples with door hardware schedule.
- C. Door Hardware Schedule: Prepared by or under the supervision of Installer's Architectural Hardware Consultant. Coordinate door hardware schedule with doors, frames, and related work to ensure proper size, thickness, hand, function, and finish of door hardware.
 - 1. Submittal Sequence: Submit door hardware schedule concurrent with submissions of Product Data, Samples, and Shop Drawings. Coordinate submission of door hardware schedule with scheduling requirements of other work to facilitate the fabrication of other work that is critical in Project construction schedule.
 - 2. Format: Use same scheduling sequence and format and use same door numbers as in door hardware schedule in the Contract Documents.

3. Content: Include the following information:
 - a. Identification number, location, hand, fire rating, size, and material of each door and frame.
 - b. Locations of each door hardware set, cross-referenced to Drawings on floor plans and to door and frame schedule.
 - c. Complete designations, including name and manufacturer, type, style, function, size, quantity, function, and finish of each door hardware product.
 - d. Fastenings and other installation information.
 - e. Explanation of abbreviations, symbols, and designations contained in door hardware schedule.
 - f. Mounting locations for door hardware.
 - g. List of related door devices specified in other Sections for each door and frame.

- D. Keying Schedule: Prepared by or under the supervision of Installer's Architectural Hardware Consultant, detailing Owner's final keying instructions for locks. Include schematic keying diagram and index each key set to unique door designations that are coordinated with the Contract Documents.

41.6 INFORMATIONAL SUBMITTALS

- A. Qualification Data: For Installer and Architectural Hardware Consultant.
- B. Product Test Reports: For compliance with accessibility requirements, for tests performed by manufacturer and witnessed by a qualified testing agency, for door hardware on doors located in accessible routes.
- C. Field quality-control reports.
- D. Sample Warranty: For special warranty.

41.7 CLOSEOUT SUBMITTALS

- A. Maintenance Data: For each type of door hardware to include in maintenance manuals.
 1. Submit 3 sets, in appropriately sized 3-ring binders, with cover sheets including project name, location, installer contact information, and project completion date.
- B. Schedules: Final door hardware and keying schedule.
 1. Edit Schedule(s) to reflect "AS-INSTALLED" for each item.
 2. Final "AS-INSTALLED" wiring diagrams for each electrified product.
- C. One set of special tools special tools required for maintenance and adjustment of hardware, including changing of cylinders.

41.8 QUALITY ASSURANCE

- A. Installer Qualifications: Supplier of products and an employer of workers trained and approved by product manufacturers and of an Architectural Hardware Consultant who is available during the course of the Work to consult Contractor, Architect, and Owner about door hardware and keying.

1. Warehousing Facilities: In Project's vicinity.
 2. Scheduling Responsibility: Preparation of door hardware and keying schedule.
- B. Architectural Hardware Consultant Qualifications: A person who is experienced in providing consulting services for door hardware installations that are comparable in material, design, and extent to that indicated for this Project and who is currently certified by DHI as an Architectural Hardware Consultant (AHC).

41.9 DELIVERY, STORAGE, AND HANDLING

- A. Inventory door hardware on receipt and provide secure lock-up for door hardware delivered to Project site.
- B. Tag each item or package separately with identification coordinated with the final door hardware schedule, and include installation instructions, templates, and necessary fasteners with each item or package.
- C. Deliver keys and permanent cores to Owner by registered mail or overnight package service.

41.10 WARRANTY

- A. Special Warranty: Manufacturer agrees to repair or replace components of door hardware that fail in materials or workmanship within specified warranty period.
 1. Failures include, but are not limited to, the following:
 - a. Structural failures including excessive deflection, cracking, or breakage.
 - b. Faulty operation of doors and door hardware.
 - c. Deterioration of metals, metal finishes, and other materials beyond normal weathering and use.
 2. Warranty Period: Three years from date of Substantial Completion unless otherwise indicated below:
 - a. Locks and Cylinders: Lifetime years from date of Substantial Completion.
 - b. Exit Devices: Five years from date of Substantial Completion.
 - c. Manual Closers: 10 years from date of Substantial Completion.
 - d. Concealed Floor Closers: 10 years from date of Substantial Completion.
 - e. All other Hardware: Two years from date of Substantial Completion.

41.11 REGULATORY REQUIREMENTS

- A. Door and Gate Hardware – (All requirements below shall apply to gates as well):
 1. Door/doorways as part of an accessible route shall comply with CBC Sections 11B-404.
 2. The clear opening width for a door shall be 32 inches minimum. For a swinging door it shall be measured between the face of the door and the stop, with the door open 90 degrees. There shall be no projections into it below 34 inches and 4 inches maximum projections into it between 34 inches and 80 inches above the finish floor or ground.

- Door closers and stops shall be permitted to be 78 inches minimum above the finish floor or ground. CBC Section 11B-404.2.3
3. Handles, pulls, latches, locks and other operable parts on accessible door shall comply with CBC Section 11B-309.4 and shall be operable with one hand and shall not require tight grasping, pinching, or twisting of the wrist. Operable parts of such hardware shall be 34 inches minimum and 44 inches maximum above the finish floor or ground. Where sliding doors are in the fully open position, operating hardware shall be exposed and usable from both sides. CBC Section 11B-404.2.7
 4. The force for pushing or pulling open a door shall be as follows: CBC 11B-404.2.9.
 - a. Interior hinged doors, sliding or folding doors, and exterior hinged doors: 5 pounds (22.2 N) maximum. Required fire doors: the minimum opening force allowable by the DSA authority, not to exceed 15 pounds (66.7 N). These forces do not apply to the force required to retract latch bolts or disengage other devices that hold the door in a closed position.
 - b. The force required for activating any operable parts, such as lever hardware, or disengaging other devices shall be 5 pounds (22.2 N) maximum to comply with CBC Section 11B-309.4
 5. Door closing speed shall be as follows: CBC Section 11B-404.2.8
 - a. Closer shall be adjusted so that the required time to move a door from an open position of 90 degrees to a position of 12 degrees from the latch is 5 seconds minimum.
 - b. Spring hinges shall be adjusted so that the required time to move a door from an open position of 70 degrees to the closed position is 1.5 seconds minimum.
 6. Thresholds shall comply with CBC 11B-404.2.5
 7. Floor stops shall not be located in the path of travel and 4 inches maximum from walls.
 8. Hardware (including panic hardware) shall not be provided with "Night Latch" (NL) function for any accessible doors or gates unless the following conditions are met: (Such conditions must be clearly demonstrated and indicated in the specifications)
 - a. Such hardware has a 'dogging' feature.
 - b. It is dogged during the time the facility is open.
 - c. Such 'dogging' operation is performed only by employees as their job function (non-public use).

PART 42 - PRODUCTS

42.1 MANUFACTURERS

- A. City-approved manufacturers are Best Access Systems, or Folger Adams with Best Lock.

42.2 PERFORMANCE REQUIREMENTS

- A. Means of Egress Doors: Latches do not require more than 5 lbf (22 N) to release the latch. Locks do not require use of a key, tool, or special knowledge for operation.
- B. Accessibility Requirements: For door hardware on doors in an accessible route, comply with the DOJ's "2010 ADA Standards for Accessible Design" and California Title 24 Building Standards Code.

1. Provide operating devices that do not require tight grasping, pinching, or twisting of the wrist and that operate with a force of not more than 5 lbf (22.2 N).
 2. Comply with the following maximum opening-force requirements:
 - a. Interior, Non-Fire-Rated Hinged Doors: 5 lbf (22.2 N) applied perpendicular to door.
 - b. Sliding or Folding Doors: 5 lbf (22.2 N) applied parallel to door at latch.
 - c. Fire Doors: Minimum opening force allowable by authorities having jurisdiction.
 3. Bevel raised thresholds with a slope of not more than 1:2. Provide thresholds not more than 1/2 inch (13 mm) high.
 4. Adjust door closer sweep periods so that, from an open position of 90 degrees, the door will take at least 5 seconds to move to a position of 12 degrees from the latch.
 5. Adjust spring hinges so that, from an open position of 70 degrees, the door will take at least 1.5 seconds to move to the closed position.
- C. City Requirement: Door in the following locations will have locks which are ANSI series 1000 Grade 1 SECURITY and Grade 1 OPERATIONAL. Locks will meet UL 437 requirements.
1. Rooms containing narcotics.
 2. Rooms that contain an armory.
 3. Exterior doors for Police Facilities.
 4. Exterior doors for Court Facilities.
 5. Doors to Judges Chambers.
 6. Any exterior door in a remote location or subject to high vandalism.
- D. City Requirement: Cylindrical lock sets may be used only on interior non-high-traffic openings. Locks will have a replaceable sheer lug which when broken will disable the lever. Clutch mechanisms will not be allowed. Locks will have 7-pin interchangeable cores. Cylindrical locks MAY NOT be installed on exterior doors.

42.3 SCHEDULED DOOR HARDWARE

- A. Provide products for each door that comply with requirements indicated in Part 2 and door hardware schedule.
1. Door hardware is scheduled in Part 3.

42.4 HINGES

- A. Hinges: BHMA A156.1. Provide template-produced hinges for hinges installed on hollow-metal doors and hollow-metal frames.
- B. Self-Closing Hinges and Pivots: BHMA A156.17.
- C. Center-Hung and Offset Pivots: BHMA A156.4.
- D. Tested and approved by BHMA for all applicable ANSI Standards for type, size, function and finish
- E. UL10C listed for Fire rated doors

F. Quantity per Door Leaf (Minimum) unless otherwise specified:

Door Height	Hinges
Up to 5'-0"	2
5'-1" to 7'-7"	3
7'-8" to 10'-0"	4
10'-1" to 12'-6"	5

G. Hinge Height (Minimum) unless otherwise specified:

Door Width	Hinge Height
Up to 3'-0"	4-1/2"
3'-1" to 4'-0"	5"
Over 4'-0"	6"

H. Width: Minimum for clearance of trim and 180-degree swing.

I. Exterior Hinges: Nonremovable pin.

1. Non Removable Pin screws shall be slotted stainless steel screws.

J. Joint Tolerance: 0.012 inch maximum, gauged in CLOSED position.

K. Bearings are to be fully hardened.

L. Bearing shell is to be consistent shape with barrel.

M. Minimum of 2 permanently lubricated non-detachable bearings on standard weight hinge and 4 permanently lubricated bearing on heavy weight hinges.

N. Equip with easily seated, non-rising pins.

O. Hinges shall be full polished, front, back and barrel.

P. Hinge pin is to be fully plated.

Q. Bearing assembly is to be installed after plating.

R. Furnish five knuckles with flush ball bearings.

S. Provide hinge type as listed in schedule.

T. Types and Manufacturers:

Description	Manufacturer	Model/Series	Finish
Mortise Hinge	McKinney	55860 TA 2714 26D NRP at reverse bevel door locks.	630 / US32D
Alternate	Stanley		
Full Surface Hinge	McKinney	57717B TA2714 26D NRP. Use for retrofit doors as appropriate.	630 / US32D
Alternate	Stanley		
Continuous Hinge	Pemko	For high traffic doors	628 / US28
Alternate	Markar		

Pivot Hinge	Rixon	180 626 Offset Top Pivot	626 / US26D
Alternate	Dorma	75120 626 Offset Top Pivot 75220 626 Intermediate Pivot	

42.5 CONTINUOUS HINGES

- A. Continuous Hinges: Tested and approved by BHMA A156.26, Grade 1; minimum **0.120-inch- (3.0-mm-)** thick, hinge leaves with minimum overall width of **4 inches (102 mm)**; fabricated to full height of door and frame and to template screw locations; with components finished after milling and drilling are complete.
- B. Continuous, Gear-Type Hinges: Extruded-aluminum, pinless, geared hinge leaves joined by a continuous extruded-aluminum channel cap; with concealed, self-lubricating thrust bearings.
- C. Width: Minimum for clearance of trim and 180-degree swing.
- D. Joint Tolerance: 0.012 inch maximum, gauged in CLOSED position.
- E. Anti-spinning through fastener.
- F. Non-handed.
- G. Lifetime Warranty.
- H. Types and Manufacturers:

Description	Manufacturer	Model/Series	Finish
Continuous Hinge	Pemko	For high traffic doors	628 / US28
Alternate	Markar		

42.6 MECHANICAL LOCKS AND LATCHES

- A. Lock Functions: As indicated in door hardware schedule.
- B. Lock Throw: Comply with testing requirements for length of bolts required for labeled fire doors, and as follows:
 1. Mortise Locks: Minimum **3/4-inch (19-mm)** latchbolt throw.
- C. Lock Backset: **2-3/4 inches (70 mm)** unless otherwise indicated.
- D. Lock Trim:
 1. Description: As scheduled.
 2. Levers: Cast, solid.
 - a. Hollow levers will NOT be allowed.
 3. Escutcheons (Roses): Cast.
 4. Dummy Trim: Match lever lock trim and escutcheons.

- E. Strikes: Provide manufacturer's standard strike for each lock bolt or latchbolt complying with requirements indicated for applicable lock or latch and with strike box and curved lip extended to protect frame; finished to match lock or latch.
1. Flat-Lip Strikes: For locks with three-piece antifriction latchbolts, as recommended by manufacturer.
 2. Extra-Long-Lip Strikes: For locks used on frames with applied wood casing trim.
 3. Aluminum-Frame Strike Box: Manufacturer's special strike box fabricated for aluminum framing.
 4. Rabbet Front and Strike: Provide on locksets for rabbeted meeting stiles.
- F. Mortise Locks: Tested and approved by BHMA A156.13; Operational Grade 1, Extra Heavy-Duty; Security Grade 2; UL10C certified; stamped steel case with steel or brass parts; Series 1000.
1. Furnish UL or recognized independent laboratory certified mechanical operational testing to 4 million cycles minimum.
 2. Provide 9001-Quality Management and 14001-Environmental Management.
 3. Fit ANSI A115.1 door preparation
 4. Functions and design as indicated in the hardware groups
 5. Solid, one-piece, 3/4-inch (19mm) throw, anti-friction latchbolt made of self-lubricating stainless steel
 6. Deadbolt functions shall have 1 inch (25mm) throw bolt made of hardened stainless steel
 7. Latchbolt and Deadbolt are to extend into the case a minimum of 3/8 inch (9.5mm) when fully extended
 8. Auxiliary deadlatch to be made of one piece stainless steel, permanently lubricated
 9. Provide sufficient curved strike lip to protect door trim
 10. Lever handles must be of forged or cast brass, bronze or stainless steel construction and conform to ANSI A117.1. Levers that contain a hollow cavity are not acceptable
 11. Lock shall have self-aligning, thru-bolted trim
 12. Levers to operate a roller bearing spindle hub mechanism
 13. Mortise cylinders of lock shall have a concealed internal setscrew for securing the cylinder to the lockset. The internal setscrew will be accessible only by removing the core, with the control key, from the cylinder body.
 14. Spindle to be designed to prevent forced entry from attacking of lever
 15. Provide locksets with 7-pin removable and interchangeable core cylinders
 16. Each lever to have independent spring mechanism controlling it
 17. Core face must be the same finish as the lockset
 18. Types and Manufacturers:

Description	Manufacturer	Model/Series	Finish
Mortise Lock Set	Best	45H x J Escutcheon lever, as scheduled – NO ALTERNATE	626 / US26D
Lock Function		Room Type	
A		Entrance Lock	
R		Classroom Function	
D		Storeroom Function	
N		Passage	
L		Privacy	

Description	Manufacturer	Model/Series	Finish
Lock Set	Best	93K x D Rose lever, as scheduled – NO ALTERNATE	626 / US26D
Lock Function		Room Type	
AB		Entrance Lock 9K37 AB 53 626	
R		Classroom Function 9K37 RD4D 53 626	
D		Storeroom Function 9K37 D14D 53 626	
N		Passage 9K30 N14D 53 626	
L		Privacy 9K30 L14D 53 626	

42.7 EXIT DEVICES AND AUXILIARY ITEMS

A. Exit Devices and Auxiliary Items: BHMA A156.3.

Description	Manufacturer	Model/Series	Finish
Exit Device	Precision	See Below	630 / US32D
2100 Series Rim x 4900 Trim (single door)			
2300 Series Mortise			
2800 Series Concealed Vertical Rod			
	Use Escutcheon with lever 4900 where applicable.		
	Lever handle shall match lockset design.		
	Exits with cylinder dogging at all non-rated devices		
	Provide 'FL' fire-rated devices at labeled openings.		

42.8 LOCK CYLINDERS

A. Lock Cylinders: Tumbler type, constructed from brass or bronze, stainless steel, or nickel silver.

1. Removeable and interchangeable core system: BEST CORMAX™ Patented 7-pin.
2. All cylinder and cores must be manufactured by BEST.
3. Best key system.
4. 2 keys per lockset.
5. All cores are to be keyed into the existing Best Master key system.
6. Provide all locksets and cylinders with construction cores for contractor use.
7. Permanent cores provided at project completion.

Description	Manufacturer	Model/Series	Finish
Cylinders	Best	Mortise 1E74 x RP3 x cam required – NO ALTERNATE	626 / US26D

Description	Manufacturer	Model/Series	Finish
Key System	Best	See Requirements below:	626 / US26D

B. Standard Lock Cylinders: BHMA A156.5; Grade 1 permanent cores; face finished to match lockset.

1. Core Type: Interchangeable, Removable.
- C. High-Security Lock Cylinders: BHMA A156.30; Grade 1 permanent cores that are removable; face finished to match lockset.
1. Type: M, mechanical.
- D. Construction Cores: Provide construction cores that are replaceable by permanent cores. Provide 10 construction master keys.
1. Construction Cores will be installed by Contractor for security purposes. Construction cores will be keyed alike and interchangeable with Best cores. Cores provided by manufacturer.
 2. Contractor will provide to the City Lock Shop copies of Control Key and Operating Key upon completion.
- E. Electric Meter Room: To have SDG&E lock installed. The cylinder will be keyed to Schlage keyway VTQP AA-10. Three keys shall be provided with lock. All keys are to be turned over to the City of San Diego Lock Shop at completion of project. The contractor will obtain lock from any contracted SDG&E Locksmith for installation.
- F. Any questions, contact:
1. Carpenter Supervisor Martin Sorrell at 619-525-8550; or
 2. Lock Shop at 619-525-8552.

42.9 KEYING

- A. Provide keyed brass construction cores and keys during the construction period. Construction control and operating keys and core shall not be part of the Owner's permanent keying system or furnished in the same keyway (or key section) as the Owner's permanent keying system. Permanent cores and keys (prepared according to the accepted keying schedule) will be furnished to the Owner.
- B. The Owner, or the Owner's agent, will install permanent cores and return the construction cores to the Hardware Supplier. Construction cores and keys remain the property of the Hardware Supplier.
- C. Keying Schedule: Arrange for a keying meeting, and programming meeting with Architect Owner and hardware supplier, and other involved parties to ensure locksets and locking hardware, are functionally correct and keying and programming complies with project requirements. Furnish 3 typed copies of keying and programming schedule to Architect.
- D. Keying System: Factory registered, complying with guidelines in BHMA A156.28, appendix. Provide one extra key blank for each lock.
1. Existing Factory-Registered Grand Master Key System:
 - a. Grand master key locks to Owner's existing system.
 2. Transmit Grand Masterkeys, Masterkeys and other Security keys to Owner by Registered Mail, return receipt requested.
 3. Furnish keys in the following quantities:
 - a. 1 each Grand Masterkeys.
 - b. 4 each Masterkeys.
 - c. 2 each Change keys each keyed core.

- d. 15 each Construction masterkeys.
- e. 1 each Control keys.

E. Permanent Keys and Cores: Brass.

- 1. Stamping: Stamped with the applicable key mark for identification. These visual key control marks or codes will not include the actual key cuts. Permanently inscribe each key with a visual key control number and include the following notation:
 - a. Notation: "CITY OF SAN DIEGO," and "DO NOT DUPLICATE."
- 2. All keys will have visual key control.

F. Electric Meter Room: To have SDG&E lock installed. The cylinder will be keyed to Schlage keyway VTQP AA-10. Three keys shall be provided with lock. All keys are to be turned over to the City of San Diego Lock Shop at completion of project. The contractor will obtain lock from any contracted SDG&E Locksmith for installation.

G. Any questions, contact:

- 1. Carpenter Supervisor Martin Sorrell at 619-525-8550; or
- 2. Lock Shop at 619-525-8552.

42.10 KEY CONTROL SYSTEM

A. Key Control Cabinet: BHMA A156.28; metal cabinet with baked-enamel finish; containing key-holding hooks, labels, two sets of key tags with self-locking key holders, key-gathering envelopes, and temporary and permanent markers; with key capacity of 150 percent of the number of locks.

Description	Manufacturer	Model/Series
Manual Key Control	Telkee	Aristocrat wall-mounted AWC series Dual tag system. Key capability to accept all keyed locksets plus 50% expansion.

- 1. Wall-Mounted Cabinet: Grade 1 cabinet with hinged-panel door equipped with key-holding panels and pin-tumbler cylinder door lock.

B. Key Lock Boxes: Designed for storage of two keys.

- 1. Manufacturers: Subject to compliance with requirements, provide products by one of the following:
 - a. GE Security, Inc.
 - b. HPC, Inc.
 - c. Knox Company.

42.11 OPERATING TRIM

A. Operating Trim: BHMA A156.6; stainless steel unless otherwise indicated.

42.12 ACCESSORIES FOR PAIRS OF DOORS

- A. Coordinators: BHMA A156.3; consisting of active-leaf, hold-open lever and inactive-leaf release trigger; fabricated from steel with nylon-coated strike plates; with built-in, adjustable safety release; and with internal override.

Description	Manufacturer	Model/Series	Finish
Coordinator	Trimco	Mounting bracket as required.	600
Alternate	Rockwood		

- B. Carry-Open Bars: BHMA A156.3; prevent the inactive leaf from opening before the active leaf; provide polished brass or bronze carry-open bars with strike plate for inactive leaves of pairs of doors unless automatic or self-latching bolts are used.
- C. Astragals: BHMA A156.22.

Description	Manufacturer	Model/Series	Finish
Astragal	Pemko	357 SP	600
Alternate			

42.13 SURFACE CLOSERS

- A. Surface Closers: Tested and approved by BHMA A156.4, Grade 1; UL10C Certified; rack-and-pinion hydraulic type with adjustable sweep and latch speeds controlled by key-operated valves and forged-steel main arm. Comply with manufacturer's written instructions for size of door closers depending on size of door, exposure to weather, and anticipated frequency of use. Provide factory-sized closers, adjustable to meet field conditions and requirements for opening force.
 1. Provide 9001-Quality Management and 14001-Environmental Management.
 2. Closer shall have extra-duty arms and knuckles
 3. Conform to ANSI 117.1
 4. Maximum 2 7/16 inch case projection with non-ferrous cover
 5. Separate adjusting valves for closing and latching speed, and backcheck
 6. Provide adapter plates, shim spacers and blade stop spacers as required by frame and door conditions
 7. Full rack and pinion type closer with 1½" minimum bore
 8. Mount closers on non-public side of door, unless otherwise noted in specification
 9. Closers shall be non-handed, non-sized and multi-sized.
 10. Types and Manufacturers:

Description	Manufacturer	Model/Series	Finish
Closers	LCN	See Below	689
4040XP RW/PA TBSRT			
4040XP SHCNS TBSRT			
1461 RW/PA TBSRT			
All door frames to be reinforced at closer.			
Provide 'SNB' Sex nuts and bolts as needed.			
35-40-EN			

Alternate	Sargent
-----------	---------

42.14 CONCEALED CLOSERS

- A. Concealed Closers: BHMA A156.4; rack-and-pinion hydraulic type with adjustable sweep and latch speeds controlled by key-operated valves. Comply with manufacturer's written instructions for size of door closers depending on size of door, exposure to weather, and anticipated frequency of use. Provide factory-sized closers, adjustable to meet field conditions and requirements for opening force.

42.15 CLOSER HOLDER RELEASE DEVICES

- A. Closer Holder Release Devices: BHMA A156.15; Grade 1; closer connected with separate or integral releasing and fire- or smoke-detecting devices. Door shall become self-closing on interruption of signal to release device. Automatic release is activated by loss of power.

42.16 MECHANICAL STOPS AND HOLDERS

- A. Wall- and Floor-Mounted Stops: BHMA A156.16.

Description	Manufacturer	Model/Series	Finish
Door Stop	Trimco	Allow for max swing of doors. Backing required at wall stops.	630 / US32D 626 / US26D
Alternate	Rockwood		

42.17 OVERHEAD STOPS AND HOLDERS

- A. Overhead Stops and Holders: BHMA A156.8.

Description	Manufacturer	Model/Series	Finish
Overhead Stop and Holder	Glynn & Johnson		630 / US32D
Alternate	Sargent		

42.18 DOOR GASKETING

- A. Door Gasketing: BHMA A156.22; with resilient or flexible seal strips that are easily replaceable and readily available from stocks maintained by manufacturer.
- B. Weatherstripping: Provide at head and jambs only those units where resilient or flexible seal strip is easily replaceable. Where bar-type weatherstrip is used with parallel arm mounted closers install weatherstrip first.
 1. Weatherstrip shall be resilient seal of (Neoprene, Polyurethane, Vinyl, Pile, Nylon Brush, Silicone)
 2. UL10C Positive Pressure rated seal set when required.

- C. Door Bottoms/Sweeps: Surface mounted or concealed door bottom where listed in the hardware sets.
 1. Door seal shall be resilient seal of (Neoprene, Polyurethane, Nylon Brush, Silicone)
 2. UL10C Positive Pressure rated seal set when required.

D. Types and Manufacturers:

Description	Manufacturer	Model/Series	Finish
Smoke Seal	Pemko	S88 (verify color)	
Alternate			
Weather Seal	Pemko	303_S (at head/jambs)	628
Alternate			

- E. Maximum Air Leakage: When tested according to ASTM E 283 with tested pressure differential of 0.3-inch wg (75 Pa), as follows:
 1. Gasketing on Single Doors: 0.3 cfm/sq. ft. (3 cu. m per minute/sq. m) of door opening.
 2. Gasketing on Double Doors: 0.50 cfm per foot (0.000774 cu. m/s per m) of door opening.

42.19 THRESHOLDS

- A. Thresholds: BHMA A156.21; fabricated to full width of opening indicated.
- B. Thresholds shall be aluminum beveled type with maximum height of 1/2" for conformance with ADA requirements. Furnish as specified and per details. Provide fasteners and screws suitable for floor conditions.
- C. Types and Manufacturers:

Description	Manufacturer	Model/Series	Finish
Threshold	Pemko	Furnish as detailed on Drawings	628
Alternate			

42.20 METAL PROTECTIVE TRIM UNITS

- A. Metal Protective Trim Units: BHMA A156.6; fabricated from 0.050-inch- (1.3-mm-) thick stainless steel; with manufacturer's standard machine or self-tapping screw fasteners.

42.21 AUXILIARY DOOR HARDWARE

- A. Auxiliary Hardware: BHMA A156.16.

Description	Manufacturer	Model/Series	Finish
Pull	Trimco		630
Alternate	Rockwood		
Push Plate	Trimco		630
Alternate	Rockwood		
Kick Plate	Trimco		630

Alternate	Rockwood		
Armor Plate	Trimco		630
Alternate	Rockwood		
Door Sweep	Pemko	345V	628
Alternate			

42.22 FABRICATION

- A. Manufacturer's Nameplate: Do not provide products that have manufacturer's name or trade name displayed in a visible location except in conjunction with required fire-rating labels and as otherwise approved by Architect.
 - 1. Manufacturer's identification is permitted on rim of lock cylinders only.
- B. Base Metals: Produce door hardware units of base metal indicated, fabricated by forming method indicated, using manufacturer's standard metal alloy, composition, temper, and hardness. Furnish metals of a quality equal to or greater than that of specified door hardware units and BHMA A156.18.
- C. Fasteners: Provide door hardware manufactured to comply with published templates prepared for machine, wood, and sheet metal screws. Provide screws that comply with commercially recognized industry standards for application intended, except aluminum fasteners are not permitted. Provide Phillips flat-head screws with finished heads to match surface of door hardware unless otherwise indicated.
 - 1. Concealed Fasteners: For door hardware units that are exposed when door is closed, except for units already specified with concealed fasteners. Do not use through bolts for installation where bolt head or nut on opposite face is exposed unless it is the only means of securely attaching the door hardware. Where through bolts are used on hollow door and frame construction, provide sleeves for each through bolt.
 - 2. Fire-Rated Applications:
 - a. Wood or Machine Screws: For the following:
 - 1) Hinges mortised to doors or frames; use threaded-to-the-head wood screws for wood doors and frames.
 - 2) Strike plates to frames.
 - 3) Closers to doors and frames.
 - b. Steel Through Bolts: For the following unless door blocking is provided:
 - 1) Surface hinges to doors.
 - 2) Closers to doors and frames.
 - 3) Surface-mounted exit devices.
 - 3. Spacers or Sex Bolts: For through bolting of hollow-metal doors.
 - 4. Gasketing Fasteners: Provide noncorrosive fasteners for exterior applications and elsewhere as indicated.

42.23 FINISHES

- A. Provide finishes complying with BHMA A156.18 as indicated in door hardware schedule.
- B. Protect mechanical finishes on exposed surfaces from damage by applying a strippable, temporary protective covering before shipping.
- C. Appearance of Finished Work: Variations in appearance of abutting or adjacent pieces are acceptable if they are within one-half of the range of approved Samples. Noticeable variations in the same piece are not acceptable. Variations in appearance of other components are acceptable if they are within the range of approved Samples and are assembled or installed to minimize contrast.
- D. Powder coat door closers to match other hardware, unless otherwise noted.
- E. Aluminum items shall be finished to match predominant adjacent material. Seals to coordinate with frame color.

PART 43 - EXECUTION

43.1 EXAMINATION

- A. Examine doors and frames, with Installer present, for compliance with requirements for installation tolerances, labeled fire-rated door assembly construction, wall and floor construction, and other conditions affecting performance of the Work.
- B. DOOR AND FRAME PREP (City requirements): Before hardware installation, verify that all doors and frames are properly prepared to receive the specified hardware. Hollow metal frames shall be prepared for ANSI strike plates per A115.1-2 (4-7/8" high), hinge preps will be mortised and reinforced with a minimum of 10 gauge reinforcement material; minimum of 14 gauge reinforcement material for closer. Hollow metal doors shall be properly prepared and reinforced with a minimum of 16 gauge material for either mortised or cylindrical locks as specified.
 - 1. Closer Reinforcement: All hollow metal doors receiving door closers shall have 14 gauge reinforcement. In the event this is not possible, the use of sex bolts is mandatory.
 - 2. Wood doors shall be factory prepared to receive the scheduled hardware.
- C. HARDWARE INSTALLATION (City requirement): The manufacturer's representative for the locking devices and closing devices must inspect the prepared doors and frames, and approve in writing, prior to the installation of their product.
- D. Proceed with installation only after unsatisfactory conditions have been corrected.

43.2 INSTALLATION

- A. Mounting Heights: Mount door hardware units at heights indicated on Drawings unless otherwise indicated or required to comply with governing regulations.
- B. Install each door hardware item to comply with manufacturer's written instructions. Where cutting and fitting are required to install door hardware onto or into surfaces that are later to

be painted or finished in another way, coordinate removal, storage, and reinstallation of surface protective trim units with finishing work. Do not install surface-mounted items until finishes have been completed on substrates involved.

1. Set units level, plumb, and true to line and location. Adjust and reinforce attachment substrates as necessary for proper installation and operation.
 2. Drill and countersink units that are not factory prepared for anchorage fasteners. Space fasteners and anchors according to industry standards.
 3. Installed hardware using the manufacturers fasteners provided. Drill and tap all screw holes located in metallic materials. Do not use "Riv-Nuts" or similar products.
- C. Hinges: Install types and in quantities indicated in door hardware schedule, but not fewer than the number recommended by manufacturer for application indicated or one hinge for every **30 inches (750 mm)** of door height, whichever is more stringent, unless other equivalent means of support for door, such as spring hinges or pivots, are provided.
- D. Intermediate Offset Pivots: Where offset pivots are indicated, provide intermediate offset pivots in quantities indicated in door hardware schedule, but not fewer than one intermediate offset pivot per door and one additional intermediate offset pivot for every **30 inches (750 mm)** of door height greater than **90 inches (2286 mm)**.
- E. Lock Cylinders: Install construction cores to secure building and areas during construction period.
1. Furnish permanent cores to Owner for installation.
- F. Key Control System:
1. Key Control Cabinet: Tag keys and place them on markers and hooks in key control system cabinet, as determined by final keying schedule.
 2. Key Lock Boxes: Install where indicated or approved by Architect to provide controlled access for fire and medical emergency personnel.
 3. Key Control System Software: Set up multiple-index system based on final keying schedule.
- G. Thresholds: Set thresholds for exterior doors and other doors indicated in full bed of sealant complying with requirements specified in Section 079200 "Joint Sealants."
- H. Stops: Provide floor stops for doors unless wall or other type stops are indicated in door hardware schedule. Do not mount floor stops where they will impede traffic.
- I. Perimeter Gasketing: Apply to head and jamb, forming seal between door and frame.
1. Do not notch perimeter gasketing to install other surface-applied hardware.
- J. Meeting Stile Gasketing: Fasten to meeting stiles, forming seal when doors are closed.
- K. Door Bottoms: Apply to bottom of door, forming seal with threshold when door is closed.

43.3 FIELD QUALITY CONTROL

- A. Independent Architectural Hardware Consultant: Engage a qualified independent Architectural Hardware Consultant to perform inspections and to prepare inspection reports.

1. Independent Architectural Hardware Consultant will inspect door hardware and state in each report whether installed work complies with or deviates from requirements, including whether door hardware is properly installed and adjusted.

- B. **HARDWARE INSTALLATION (City requirement):** The manufacturer's representative for the locking devices and closing devices must inspect the installed hardware, and approve in writing, following the installation of their product. Hardware installed incorrectly must be reported to the Engineer prior to Final Punch List.

43.4 ADJUSTING

- A. **Initial Adjustment:** Adjust and check each operating item of door hardware and each door to ensure proper operation or function of every unit. Replace units that cannot be adjusted to operate as intended. Adjust door control devices to compensate for final operation of heating and ventilating equipment and to comply with referenced accessibility requirements.

1. **Door Closers:** Adjust sweep period to comply with accessibility requirements and requirements of authorities having jurisdiction.
2. **Spring Hinges:** Adjust to achieve positive latching when door is allowed to close freely from an open position of 70 degrees and so that closing time complies with accessibility requirements of authorities having jurisdiction.
3. **Electric Strikes:** Adjust horizontal and vertical alignment of keeper to properly engage lock bolt.
4. **Exit Devices:** Check latchset, lockset, and exit devices are properly installed and adjusted to ensure proper operation.
 - a. Verify levers are free from binding.
 - b. Ensure latchbolts and dead bolts are engaged into strike and hardware is functioning.
5. Report findings, in writing, to architect indicating that all hardware is installed and functioning properly. Include recommendations outlining corrective actions for improperly functioning hardware if required.

43.5 CLEANING AND PROTECTION

- A. Clean adjacent surfaces soiled by door hardware installation.
- B. Clean operating items as necessary to restore proper function and finish.
- C. Provide final protection and maintain conditions that ensure that door hardware is without damage or deterioration at time of Substantial Completion.

43.6 MAINTENANCE SERVICE

- A. **Maintenance Tools and Instructions:** Furnish a complete set of specialized tools and maintenance instructions for Owner's continued adjustment, maintenance, and removal and replacement of door hardware.

43.8 DOOR HARDWARE SCHEDULE

Manufacturer List

<u>Code</u>	<u>Name</u>
AB	ABH Manufacturing Inc.
BE	Best Access Systems
LC	LCN Closers
NA	National Guard
ST	Stanley
TR	Trimco

Finish List

<u>Code</u>	<u>Description</u>
AL	Aluminum
AL	Aluminum (BHMA 689)
626	Satin Chromium Plated
630	Satin Stainless Steel
US32D	Stainless Steel, Dull

Option List

<u>Code</u>	<u>Description</u>
B4E	Beveled 4 Edges
CSK	Counter Sunk Screw Holes
VIB	Double Visual Indicator Option

Hardware Sets

SET #1

Doors: 1

2	Continuous Hinge	661HD UL	AL	ST
2	Automatic Flush Bolt	3810-12	626	TR
1	Lockset	45H-7A14J PATD	626	BE
2	Overhead Holder	4430 Series	US32D	AB
2	Kick Plate	K0050 10" x 1" LDW B4E CSK	630	TR
1	Weatherstrip	160SA Head & Jambs		NA
1	Astragal	196NA		NA
1	Drip Cap	16 A - 4" ODW		NA
2	Door Sweep	200NA		NA
1	Handicap Threshold	513A	AL	NA

SET #2

Doors: 2, 6, 11

1	Continuous Hinge	661HD UL	AL	ST
1	Lockset	45H-7A14J PATD	626	BE
1	Closer	4040 XP SCUSH	AL	LC
1	Kick Plate	K0050 10" x 2" LDW B4E CSK	630	TR
1	Weatherstrip	160SA Head & Jambs		NA
1	Drip Cap	16 A - 4" ODW		NA
1	Door Sweep	200NA		NA
1	Handicap Threshold	513A	AL	NA

SET #3

Doors: 3, 4, 5, 7, 8, 9, 10

1 Continuous Hinge	661HD UL	AL	ST
1 Privacy Set	45H-0L14J VIB (WITH LEVER TYPE THUMB TURN)	626	BE
1 Closer	4040 XP SCUSH	AL	LC
1 Drip Cap	16 A - 4" ODW		NA
1 Gasketing	5050B Head & Jambs		NA

END OF SECTION 087100

SECTION 099600

HIGH-PERFORMANCE COATINGS

PART 44 - GENERAL

44.1 RELATED DOCUMENTS

- A. Drawings and general provisions of the Contract - Standard Specifications for Public Works Construction 'The GREENBOOK' and City Supplement 'The WHITEBOOK', latest editions, including Supplemental Supplementary Provisions (SSPs), apply to this Section.

44.2 SUMMARY

- A. Section includes surface preparation and the application of high-performance coating systems on the following substrates:

- 1. Exterior Substrates:

- a. Concrete, vertical surfaces.
- b. Fiber-cement board.
- c. Concrete masonry units (CMUs).
- d. Steel.
- e. Galvanized metal.
- f. Wood.

- 2. Interior Substrates:

- a. NOT APPLICABLE. ALL SUBSTRATES ARE CONSIDERED EXTERIOR ON ALL SURFACES.

- B. Related Requirements:

- 1. Section 05 12 00 "Structural Steel Framing" and Section 05 12 13 "Architecturally Exposed Structural Steel Framing" for shop priming of structural steel with primers specified in this Section.

44.3 DEFINITIONS

- A. MPI Gloss Level 5: 35 to 70 units at 60 degrees, according to ASTM D 523.
- B. MPI Gloss Level 6: 70 to 85 units at 60 degrees, according to ASTM D 523.
- C. MPI Gloss Level 7: More than 85 units at 60 degrees, according to ASTM D 523.

44.4 ACTION SUBMITTALS

- A. Product Data: For each type of product. Include preparation requirements and application instructions.

1. Include printout of current "MPI Approved Products List" for each product category specified, with the proposed product highlighted.
 2. Indicate VOC content.
- B. Samples for Initial Selection: For each type of topcoat product indicated.
- C. Samples for Verification: For each type of coating system and each color and gloss of topcoat indicated.
1. Submit Samples on rigid backing, 8 inches (200 mm) square.
 2. Apply coats on Samples in steps to show each coat required for system.
 3. Label each coat of each Sample.
 4. Label each Sample for location and application area.
- D. Product List: Cross-reference to coating system and locations of application areas. Use same designations indicated on Drawings and in schedules. Include color designations.

44.5 MAINTENANCE MATERIAL SUBMITTALS

- A. Furnish extra materials, from the same product run, that match products installed and that are packaged with protective covering for storage and identified with labels describing contents.
1. Coatings: 5 gallons of each material and color applied.

44.6 DELIVERY, STORAGE, AND HANDLING

- A. Store materials not in use in tightly covered containers in well-ventilated areas with ambient temperatures continuously maintained at not less than 45 deg F (7 deg C).
1. Maintain containers in clean condition, free of foreign materials and residue.
 2. Remove rags and waste from storage areas daily.

44.7 FIELD CONDITIONS

- A. Apply coatings only when temperature of surfaces to be coated and ambient air temperatures are between 50 and 95 deg F (10 and 35 deg C).
- B. Do not apply coatings when relative humidity exceeds 85 percent; at temperatures less than 5 deg F (3 deg C) above the dew point; or to damp or wet surfaces.
- C. Do not apply exterior coatings in snow, rain, fog, or mist.

PART 45 - PRODUCTS

45.1 MANUFACTURERS

- A. Products: Subject to compliance with requirements, provide product listed in the Exterior High-Performance Coating Schedule for the coating category indicated.

45.2 HIGH-PERFORMANCE COATINGS, GENERAL

- A. MPI Standards: Products shall comply with MPI standards indicated and shall be listed in its "MPI Approved Products Lists."
- B. Material Compatibility:
 - 1. Materials for use within each paint system shall be compatible with one another and substrates indicated, under conditions of service and application as demonstrated by manufacturer, based on testing and field experience.
 - 2. For each coat in a paint system, products shall be recommended in writing by topcoat manufacturers for use in paint system and on substrate indicated.
 - 3. Products shall be of same manufacturer for each coat in a coating system.
- C. Colors: Match Engineer's samples.

45.3 SOURCE QUALITY CONTROL

- A. Testing of Coating Materials: City reserves the right to invoke the following procedure:
 - 1. City will engage the services of a qualified testing agency to sample coating materials. Contractor will be notified in advance and may be present when samples are taken. If coating materials have already been delivered to Project site, samples may be taken at Project site. Samples will be identified, sealed, and certified by testing agency.
 - 2. Testing agency will perform tests for compliance with product requirements.
 - 3. City may direct Contractor to stop applying coatings if test results show materials being used do not comply with product requirements. Contractor shall remove noncomplying coating materials from Project site, pay for testing, and recoat surfaces coated with rejected materials. Contractor will be required to remove rejected materials from previously coated surfaces if, on recoating with complying materials, the two coatings are incompatible.

PART 46 - EXECUTION

46.1 EXAMINATION

- A. Examine substrates and conditions, with Applicator present, for compliance with requirements for maximum moisture content and other conditions affecting performance of the Work.
- B. Maximum Moisture Content of Substrates: When measured with an electronic moisture meter as follows:
 - 1. Concrete: 12 percent.
 - 2. Fiber-Cement Board: 12 percent.
 - 3. Masonry (Clay and CMUs): 12 percent.
 - 4. Wood: 15 percent.
 - 5. Gypsum Board: 12 percent.
 - 6. Plaster: 12 percent.

- C. Gypsum Board Substrates: Verify that finishing compound is sanded smooth.
- D. Plaster Substrates: Verify that plaster is fully cured.
- E. Verify suitability of substrates, including surface conditions and compatibility, with existing finishes and primers.
- F. Proceed with coating application only after unsatisfactory conditions have been corrected.
 - 1. Application of coating indicates acceptance of surfaces and conditions.

46.2 PREPARATION

- A. Comply with manufacturer's written instructions and recommendations in "MPI Architectural Painting Specification Manual" applicable to substrates and coating systems indicated.
- B. Remove hardware, covers, plates, and similar items already in place that are removable and are not to be painted. If removal is impractical or impossible because of size or weight of item, provide surface-applied protection before surface preparation and painting.
 - 1. After completing painting operations, use workers skilled in the trades involved to reinstall items that were removed. Remove surface-applied protection if any.
- C. Clean substrates of substances that could impair bond of coatings, including dust, dirt, oil, grease, and incompatible paints and encapsulants.
 - 1. Remove incompatible primers and reprime substrate with compatible primers or apply tie coat as required to produce coating systems indicated.
- D. Concrete Substrates: Remove release agents, curing compounds, efflorescence, and chalk. Do not coat surfaces if moisture content or alkalinity of surfaces to be coated exceeds that permitted in manufacturer's written instructions.
 - 1. Abrasive blast clean surfaces to comply with SSPC-SP 7/NACE No. 4.
- E. Masonry Substrates: Remove efflorescence and chalk. Do not coat surfaces if moisture content, alkalinity of surfaces, or alkalinity of mortar joints exceeds that permitted in manufacturer's written instructions.
 - 1. Clean surfaces with pressurized water. Use pressure range of **1500 to 4000 psi** (**10 350 to 27 580 kPa**) at **6 to 12 inches** (**150 to 300 mm**).
- F. Shop-Primed Steel Substrates: Clean field welds, bolted connections, and areas where shop paint is abraded. Paint exposed areas with the same material as used for shop priming to comply with SSPC-PA 1 for touching up shop-primed surfaces.
- G. Galvanized-Metal Substrates: Remove grease and oil residue from galvanized sheet metal by mechanical methods to produce clean, lightly etched surfaces that promote adhesion of subsequently applied coatings.
- H. Wood Substrates:
 - 1. Scrape and clean knots. Before applying primer, apply coat of knot sealer that is recommended in writing by topcoat manufacturer for coating system indicated.

2. Sand surfaces that will be exposed to view and dust off.
3. Prime edges, ends, faces, undersides, and backsides of wood.
4. After priming, fill holes and imperfections in the finish surfaces with filler that is recommended in writing by topcoat manufacturer for coating system indicated. Sand smooth when dried.

46.3 APPLICATION

- A. Apply high-performance coatings according to manufacturer's written instructions and recommendations in "MPI Architectural Painting Specification Manual."
 1. Use applicators and techniques suited for coating and substrate indicated.
 2. Coat surfaces behind movable equipment and furniture same as similar exposed surfaces. Before final installation, coat surfaces behind permanently fixed equipment or furniture with prime coat only.
 3. Coat backsides of access panels, removable or hinged covers, and similar hinged items to match exposed surfaces.
 4. Do not apply coatings over labels of independent testing agencies or equipment name, identification, performance rating, or nomenclature plates.
- B. If undercoats or other conditions show through final coat, apply additional coats until cured film has a uniform coating finish, color, and appearance.
- C. Apply coatings to produce surface films without cloudiness, spotting, holidays, laps, brush marks, runs, sags, ropiness, or other surface imperfections. Produce sharp glass lines and color breaks.

46.4 FIELD QUALITY CONTROL

- A. Dry Film Thickness Testing: City may engage the services of a qualified testing and inspecting agency to inspect and test coatings for dry film thickness.
 1. Contractor shall touch up and restore coated surfaces damaged by testing.
 2. If test results show that dry film thickness of applied coating does not comply with coating manufacturer's written recommendations, Contractor shall pay for testing and apply additional coats as needed to provide dry film thickness that complies with coating manufacturer's written recommendations.

46.5 CLEANING AND PROTECTION

- A. At end of each workday, remove rubbish, empty cans, rags, and other discarded materials from Project site.
- B. After completing coating application, clean spattered surfaces. Remove spattered coatings by washing, scraping, or other methods. Do not scratch or damage adjacent finished surfaces.
- C. Protect work of other trades against damage from coating operation. Correct damage to work of other trades by cleaning, repairing, replacing, and recoating, as approved by Engineer, and leave in an undamaged condition.

- D. At completion of construction activities of other trades, touch up and restore damaged or defaced coated surfaces.

46.6 EXTERIOR HIGH-PERFORMANCE COATING SCHEDULE

A. Concrete Substrates, Vertical Surfaces:

- 1. Clear Anti-graffiti system:
 - a. Manufacturer: Monopole, Inc. or approved equal.
 - b. First Coat: Aquaseal ME12 (Item 5200).
 - c. Second Coat: Permashield Base (Item 6100).
 - d. Third Coat: Permasheild Premium (Item 5600) Matte finish.
 - e. Fourth Coat: Permasheild Permium (Item 5600) Matte finish.

B. Cement Board Substrates:

- 1. Epoxy-Modified Latex System MPI EXT 3.3D
 - a. Prime Coat: Epoxy-modified latex, matching topcoat.
 - b. Intermediate Coat: Epoxy-modified latex, matching topcoat.
 - c. Topcoat: Epoxy-modified latex, semi-gloss (MPI Gloss Level 5), MPI #215.
 - 1) AkzoNobel; Devoe High Performance Coatings – True Glaze WB 4426 Water Borne Epoxy.

C. CMU Substrates:

- 1. Clear Anti-graffiti system:
 - a. Manufacturer: Monopole, Inc. or approved equal.
 - b. First Coat: Aquaseal ME12 (Item 5200).
 - c. Second Coat: Permashield Base (Item 6100).
 - d. Third Coat: Permasheild Premium (Item 5600) Matte finish.
 - e. Fourth Coat: Permasheild Permium (Item 5600) Matte finish.

D. Steel Substrates:

- 1. Pigmented Polyurethane over Epoxy Zinc-Rich Primer System MPI EXT 5.1P:
 - a. Prime Coat: Primer, zinc rich, epoxy, MPI #20.
 - 1) Sherwin Williams Zinc Clad IV.
 - b. Intermediate Coat: Epoxy, gloss, MPI #77.
 - 1) Sherwin Williams Tile-Clad HS Epoxy.
 - c. Topcoat: Polyurethane, two component, pigmented, gloss (MPI Gloss Level 6), MPI #72.

1) Sherwin Williams Acrolon 218 HS.

E. Galvanized-Metal Substrates:

1. Pigmented Polyurethane over Epoxy Primer System MPI EXT 5.3L:

a. Prime Coat: Primer, epoxy, anti-corrosive, for meta, MPI #101.

1) Sherwin Williams Dura-Plate 235 Multi-Purpose Epoxy.

b. Intermediate Coat: Polyurethane, two component, pigmented, gloss matching topcoat.

c. Topcoat: Polyurethane, two component, pigmented, gloss (MPI Gloss Level 6), MPI #72.

1) Sherwin Williams Acrolon 218 HS.

F. Wood Substrates: Exposed framing.

1. Pigmented Polyurethane System MPI EXT 6.2J:

a. Prime Coat: Polyurethane, two component, pigmented, gloss, matching topcoat.

b. Intermediate Coat: Polyurethane, two component, pigmented, gloss, matching topcoat.

c. Topcoat: Polyurethane, two component, pigmented, gloss (MPI Gloss Level 6), MPI #72.

1) Sherwin Williams Acrolon 218 HS.

END OF SECTION 099600

SECTION 101423.13

ROOM-IDENTIFICATION SIGNAGE

PART 47 - GENERAL

47.1 RELATED DOCUMENTS

- A. Drawings and general provisions of the Contract - Standard Specifications for Public Works Construction 'The GREENBOOK' and City Supplement 'The WHITEBOOK', latest editions, including Supplemental Supplementary Provisions (SSPs), apply to this Section.

47.2 SUMMARY

- A. Section includes room-identification signs that are directly attached to the building.

47.3 DEFINITIONS

- A. Accessible: In accordance with the accessibility standard.

47.4 ACTION SUBMITTALS

- A. Product Data: For each type of product.
- B. Shop Drawings: For room-identification signs.
 - 1. Include fabrication and installation details and attachments to other work.
 - 2. Show sign mounting heights, locations of supplementary supports to be provided by other installers, and accessories.
 - 3. Show message list, typestyles, graphic elements, including raised characters and Braille, and layout for each sign at least half size.
- C. Product Schedule: For room-identification signs. Use same designations indicated on Drawings or specified.

47.5 INFORMATIONAL SUBMITTALS

- A. Qualification Data: For Installer and manufacturer.
- B. Sample Warranty: For special warranty.

47.6 CLOSEOUT SUBMITTALS

- A. Maintenance Data: For signs to include in maintenance manuals.

47.7 MAINTENANCE MATERIAL SUBMITTALS

- A. Furnish extra materials that match products installed and that are packaged with protective covering for storage and identified with labels describing contents.
 - 1. Tools: One set(s) of specialty tools for assembling signs and replacing variable sign components.

47.8 WARRANTY

- A. Special Warranty: Manufacturer agrees to repair or replace components of signs that fail in materials or workmanship within specified warranty period.
 - 1. Failures include, but are not limited to, the following:
 - a. Deterioration of finishes beyond normal weathering.
 - b. Deterioration of embedded graphic image.
 - c. Separation or delamination of sheet materials and components.
 - 2. Warranty Period: Five years from date of Substantial Completion.

47.9 REGULATORY REQUIREMENTS

- A. Signage and Graphics – Raised Characters shall comply with CBC Section 11B-703.2:
 - 1. Depth: It shall be 1/32-inch (0.8mm) minimum above their background and shall be sans serif uppercase and be duplicated in Braille.
 - 2. Height: It shall be 5/8-inch (15.9 mm) minimum and 2 inches (51 mm) maximum based on the height of the uppercase letter ‘I’. CBC Section 11b-703.2.5
 - 3. Finish and Contrast: Characters and their background shall have a non-glare finish. Character shall contrast with their background with either light characters on a dark background or dark characters on a light background. CBC Section 11B-703.5.1
 - 4. Proportions: It shall be selected from fonts where the width of the uppercase letter “O” is 60% minimum and 110% maximum of the height of the uppercase letter “I”. Stroke thickness of the uppercase letter “I” shall be 15% maximum of the height of the character. CBC Section 11B-703.2.4 and 11B-703.2.6
 - 5. Character Spacing: Spacing between individual raised characters shall comply with CBC Section 11B-703.2.7 and 11B-703.2.8
 - 6. Format: Text shall be in a horizontal format. CBC Section 11B-703.2.9
 - 7. Braille: It shall be contracted (Grade 2) and shall comply with CBC Section 11B-703.3 and 11B-703.4. Braille dots shall have a domed or rounded shape and shall comply with CBC Table and Figure 11B-703.3.1
 - 8. Mounting Height: Tactile characters on signs shall be located 48 inches minimum to the baseline of the lowest Braille cells and 60 inches maximum to the baseline of the highest line of raised characters above the finish floor or ground surface. CBC Section and Figure 11B-703.4.1
 - 9. Mounting Location: A tactile sign shall be located per CBC Section and Figure 11B-703.4.2 as follows:
 - a. Alongside a single door at the latch side.
 - b. On the inactive leaf at double door with one active leaf.
 - c. To the right of the right-hand door at double doors with two active leaves.
 - d. On the nearest adjacent wall where there is no wall space at the latch side of a single door or at the right side of double doors with two active leaves.

- e. So that a clear floor space of 18" x 18" minimum, centered on the tactile characters, is provided beyond the arc of any door swing between the closed position and 45-degree open position.
- B. Signage and Graphics – Visual Characters shall comply with CBC Section 11B-703.5 and shall be 40 inches minimum above finish floor or ground.
- C. Signage and Graphics – Pictograms shall comply with CBC Section 11B-703.6
- D. Signage and Graphics – Symbols of Accessibility shall comply with CBC Section 11B-703.7

PART 48 - PRODUCTS

48.1 PERFORMANCE REQUIREMENTS

- A. Accessibility Standard: Comply with applicable provisions in the USDOJ's "2010 ADA Standards for Accessible Design" and 2016 California Building Code.

48.2 ROOM-IDENTIFICATION SIGNS

- A. Room-Identification Sign: Sign with smooth, uniform surfaces; with message and characters having uniform faces, eased or rounded corners, eased or chamfered edges, and precisely formed lines and profiles; and as follows:
 - 1. Panel Sign: Aluminum plate with raised graphics.
 - a. Thickness: .125 inch.
 - b. Color(s): As selected by Engineer from manufacturer's full range.
 - 2. Mounting: Surface mounted to wall with countersunk flathead vandal-proof through fasteners and either adhesive or VHB two-face tape.
 - 3. Text and Typeface: Accessible raised characters and Braille. Finish raised characters to contrast with background color, and finish Braille to match background color.
 - a. Neue Helvetica, or approved equal.

48.3 SIGN MATERIALS

- A. Aluminum Sheet and Plate: **ASTM B 209 (ASTM B 209M)**, alloy and temper recommended by aluminum producer and finisher for type of use and finish indicated.
- B. Paints and Coatings for Sheet Materials: Inks, dyes, and paints that are recommended by manufacturer for optimum adherence to surface and are UV and water resistant for colors and exposure indicated.
- C. Braille: 100% domed, direct 3D-print Braille dots, coated with exterior grade acrylic polyurethane paint.
- D. Letters: Integrally colored 1/32" thick, adhesive-backed raised letters are applied after exterior grade paint application.

48.4 ACCESSORIES

- A. Fasteners and Anchors: Manufacturer's standard as required for secure anchorage of signs, noncorrosive and compatible with each material joined, and complying with the following:
 - 1. Use concealed fasteners and anchors unless indicated to be exposed.
 - 2. For exterior exposure, furnish stainless-steel devices.
 - 3. Exposed Metal-Fastener Components, General:
 - a. Fabricated from same basic metal and finish of fastened sign unless otherwise indicated.
 - b. Fastener Heads: Use flathead or oval countersunk screws and bolts with tamper-resistant spanner-head slots unless otherwise indicated.
 - 4. Sign Mounting Fasteners:
 - a. Through Fasteners: Exposed stainless-steel fasteners matching sign finish, with type of head indicated, and installed in predrilled holes.
 - 5. All fasteners must be stainless steel 300 series or better, and color-coated to match sign background color.
- B. Adhesive: As recommended by sign manufacturer.
- C. Two-Face Tape: Manufacturer's standard high-bond, foam-core tape, **0.045 inch (1.14 mm)** thick, with adhesive on both sides.

48.5 FABRICATION

- A. General: Provide manufacturer's standard sign assemblies according to requirements indicated.
 - 1. Preassemble signs and assemblies in the shop to greatest extent possible. Disassemble signs and assemblies only as necessary for shipping and handling limitations. Clearly mark units for reassembly and installation; apply markings in locations concealed from view after final assembly.
 - 2. Mill joints to a tight, hairline fit. Form assemblies and joints exposed to weather to resist water penetration and retention.
 - 3. Conceal connections if possible; otherwise, locate connections where they are inconspicuous.
 - 4. Provide rabbets, lugs, and tabs necessary to assemble components and to attach to existing work. Drill and tap for required fasteners. Use concealed fasteners where possible; use exposed fasteners that match sign finish.

48.6 GENERAL FINISH REQUIREMENTS

- A. Protect mechanical finishes on exposed surfaces from damage by applying a strippable, temporary protective covering before shipping.
- B. Appearance of Finished Work: Noticeable variations in same piece are not acceptable. Variations in appearance of adjoining components are acceptable if they are within the range of approved Samples and are assembled or installed to minimize contrast.

48.7 ALUMINUM FINISHES

- A. Color Anodic Finish: AAMA 611, Class I, 0.018 mm or thicker.
- B. Baked-Enamel or Powder-Coat Finish: AAMA 2603 except with a minimum dry film thickness of **1.5 mils (0.04 mm)**. Comply with coating manufacturer's written instructions for cleaning, conversion coating, and applying and baking finish.
- C. Exterior grade high-performance acrylic polyurethane paint.
 - 1. Matthews Satin Acrylic Polyurethane, or equal.
 - a. Gloss level: in compliance with ADA and CBC.

PART 49 - EXECUTION

49.1 INSTALLATION

- A. General: Install signs using mounting methods indicated and according to manufacturer's written instructions.
 - 1. Install signs level, plumb, true to line, and at locations and heights indicated, with sign surfaces free of distortion and other defects in appearance.
 - 2. Install signs so they do not protrude or obstruct according to the accessibility standard.
 - 3. Before installation, verify that sign surfaces are clean and free of materials or debris that would impair installation.
- B. Accessibility: Install signs in locations on walls as indicated on Drawings and according to the accessibility standard.
- C. Mounting Methods: Installer of signs **MUST** provide option 1 or 2 below at each sign, and installation **MAY** be augmented with either of options 3 or 4. Ensure signs are fabricated with factory pre-drilled holes if utilizing option 2.
 - 1. Concealed Studs: Using a template, drill holes in substrate aligning with studs on back of sign. Remove loose debris from hole and substrate surface.
 - a. Masonry Substrates: Fill holes with adhesive. Leave recess space in hole for displaced adhesive. Place sign in position and push until flush to surface, embedding studs in holes. Temporarily support sign in position until adhesive fully sets.
 - b. Thin or Hollow Surfaces: Place sign in position and flush to surface, install washers and nuts on studs projecting through opposite side of surface, and tighten.
 - 2. Through Fasteners: Drill holes in substrate using predrilled holes in sign as template. Countersink holes in sign if required. Place sign in position and flush to surface. Install through fasteners and tighten.
 - 3. Adhesive: Clean bond-breaking materials from substrate surface and remove loose debris. Apply linear beads or spots of adhesive symmetrically to back of sign and of suitable quantity to support weight of sign after cure without slippage. Keep adhesive away from edges to prevent adhesive extrusion as sign is applied and to prevent

visibility of cured adhesive at sign edges. Place sign in position and push to engage adhesive. Temporarily support sign in position until adhesive fully sets.

4. Two-Face Tape: Clean bond-breaking materials from substrate surface and remove loose debris. Apply tape strips symmetrically to back of sign and of suitable quantity to support weight of sign without slippage. Keep strips away from edges to prevent visibility at sign edges. Place sign in position and push to engage tape adhesive.

49.2 ADJUSTING AND CLEANING

- A. Remove and replace damaged or deformed signs and signs that do not comply with specified requirements. Replace signs with damaged or deteriorated finishes or components that cannot be successfully repaired by finish touchup or similar minor repair procedures.
- B. Remove temporary protective coverings and strippable films as signs are installed.
- C. On completion of installation, clean exposed surfaces of signs according to manufacturer's written instructions and touch up minor nicks and abrasions in finish. Maintain signs in a clean condition during construction and protect from damage until acceptance by City.

END OF SECTION 101423.13

SECTION 102800

TOILET, BATH, AND LAUNDRY ACCESSORIES

PART 50 - GENERAL

50.1 RELATED DOCUMENTS

- A. Drawings and general provisions of the Contract - Standard Specifications for Public Works Construction 'The GREENBOOK' and City Supplement 'The WHITEBOOK', latest editions, including Supplemental Supplementary Provisions (SSPs), apply to this Section.

50.2 SUMMARY

- A. Section Includes:
 - 1. Public-use washroom accessories.
 - 2. Air dryers.
 - 3. Custodial accessories.

50.3 COORDINATION

- A. Coordinate accessory locations with other work to prevent interference with clearances required for access by people with disabilities, and for proper installation, adjustment, operation, cleaning, and servicing of accessories.
- B. Deliver inserts and anchoring devices set into concrete or masonry as required to prevent delaying the Work.

50.4 ACTION SUBMITTALS

- A. Product Data: For each type of product.
 - 1. Include construction details, material descriptions, dimensions of individual components and profiles, and finishes.
 - 2. Include anchoring and mounting requirements, including requirements for cutouts in other work and substrate preparation.
 - 3. Include electrical characteristics.
- B. Product Schedule: Indicating types, quantities, sizes, and installation locations by room of each accessory required.
 - 1. Identify locations using room designations indicated.
 - 2. Identify accessories using designations indicated.

50.5 INFORMATIONAL SUBMITTALS

- A. Sample Warranty: For manufacturer's special warranty.

50.6 CLOSEOUT SUBMITTALS

- A. Maintenance Data: For accessories to include in maintenance manuals.

50.7 REGULATORY REQUIREMENTS

A. Sanitary Facility Elements:

1. Elements of Sanitary facilities shall be mounted at locations in compliance with CBC Section 11B-602 through 11B-612.
2. Grab bars in toilet facilities and bathing facilities shall comply with CBC Section 11B-609. Grab bars and any wall or other surfaces adjacent to grab bars shall be free of sharp or abrasive elements and shall have rounded edges. The space around the grab bars shall be as follows:
 - a. 1-1/2 inches between the grab bar and the wall.
 - b. 1-1/2 inches minimum between the grab bar and project objects below and at the ends.
 - c. 12 inches minimum between the grab bar and projecting objects above.

PART 51 - PRODUCTS

51.1 PERFORMANCE REQUIREMENTS

- A. Electrical Components, Devices, and Accessories: Listed and labeled as defined in NFPA 70, by a qualified testing agency, and marked for intended location and application.

51.2 PUBLIC-USE WASHROOM ACCESSORIES

- A. Source Limitations: Obtain public-use washroom accessories from single source from single manufacturer.
- B. Toilet Tissue (Roll) Dispenser < C >:
 1. Description: Roll-in-reserve dispenser with hinged front secured with tumbler lockset.
 2. Mounting: Recessed at accessible toilet compartments.
 3. Operation: Noncontrol delivery with theft-resistant spindle.
 4. Capacity: Designed for 5-inch- (127-mm-) diameter tissue rolls.
 5. Material and Finish: Stainless steel, No. 4 finish (satin).
- C. Toilet Tissue (Roll) Dispenser < D >:
 1. Description: Two-piece, three-roll, slow-rolling, narrow-bar with neoprene friction sleeve toilet tissue dispenser and the following:
 2. Mounting: Surface mounted.
 3. Toilet Tissue Dispenser Capacity: 4-1/2- or 5-inch- (114- or 127-mm-) diameter tissue rolls.
 4. Toilet Tissue Dispenser Operation: Controlled delivery with neoprene friction sleeve.
 5. Material and Finish: Stainless steel, No. 4 finish (satin).
 6. Lockset: Keyed Padlock.
- D. Liquid-Soap Dispenser < E >:

1. Description: Designed for dispensing soap in liquid form.
2. Mounting: Horizontally oriented, surface mounted.
3. Capacity: 40 oz. (1.2 L).
4. Materials: Stainless steel, 22 Ga, No. 4 finish (satin). Body is drawn, one-piece, seamless construction. Clear acrylic refill-indicator window. Black molded plastic push button and spout.
5. Lockset: Tumbler type.
6. Refill Indicator: Window type.

E. Grab Bar < A >:

1. Mounting: Flanges with concealed fasteners.
2. Material: Stainless steel, 0.05 inch (1.3 mm) thick.
 - a. Finish: Smooth, No. 4 finish (satin).
3. Outside Diameter: 1-1/2 inches (38 mm).
4. Configuration and Length: Straight, 54 inches long.

F. Grab Bar < B >:

1. Mounting: Flanges with concealed fasteners.
2. Material: Stainless steel, 0.05 inch (1.3 mm) thick.
 - a. Finish: Smooth, No. 4 finish (satin).
3. Outside Diameter: 1-1/2 inches (38 mm).
4. Configuration and Length: Straight, 42 inches long.

51.3 AIR DRYERS

A. Source Limitations: Obtain air dryers from single source from single manufacturer.

B. High-Speed Air Dryer < G >:

1. Description: High-speed, air hand dryer for rapid hand drying.
2. Mounting: Recessed, Chase-mount.
3. Operation: Push-button activated with operation time of 10 to 20 seconds.
4. Cover Material and Finish: Cast aluminum, with enamel finish.
5. Electrical Requirements: 115 V, 7 A, 60Hz.
6. If air dryer unit is provide with a heating element, it must be removed prior to installation.

51.4 CHILDCARE ACCESSORIES

A. Source Limitations: Obtain childcare accessories from single source from single manufacturer.

B. Diaper Changing Station < F >:

1. Polyethylene body with stainless steel exterior.
2. Stainless Steel: Type 304, brushed finish.
3. Standard with molded-in dual liner dispensers
4. ADA cam-buckle is adjustable with one hand.
5. Smooth nylon safety belt.
6. Integral bag hooks on either side of tray.

7. ANSI compliant labels utilizing universal safety symbols.
8. 4 inch maximum profile as measured from supporting wall.
9. Pneumatic gas shock mechanism for smooth, safe open and close operations.
10. Steel support hinges.
11. ASTM G21 Anti-Bacterial: No measurable bacterial growth.
12. ASTM G22 Anti-Fungal: No measurable fungal growth.
13. Meets or exceeds ASTM F2285 Safety specifications for commercial changing stations.
14. Open changing surface projects 17 inches from supporting wall during use.

51.5 UNDERLAVATORY GUARDS

A. Underlavatory Guard < J >:

1. Manufacturers: Subject to compliance with requirements, provide products by the following:
 - a. Plumberex Specialty Products, Inc.
 - b. Approved equal.
2. Description: Insulating pipe covering for supply and drain piping assemblies that prevents direct contact with and burns from piping; allow service access without removing coverings.
3. Material and Finish: Antimicrobial, molded plastic, white.

51.6 CUSTODIAL ACCESSORIES

A. Source Limitations: Obtain custodial accessories from single source from single manufacturer.

B. Utility Shelf with Mop and Broom Holder < H >:

1. Description: With exposed edges turned down not less than **1/2 inch (13 mm)** and supported by two triangular brackets welded to shelf underside.
2. Size: **36 inches** long by **8** deep.
3. Material and Finish: Not less than nominal **18 gauge** thick stainless steel, No. 4 finish (satin).
4. Description: Unit with shelf, hooks, holders, and rod suspended beneath shelf .
5. Hooks: Three.
6. Mop/Broom Holders: Four, spring-loaded, rubber hat, cam type.
7. Material and Finish: Stainless steel, No. 4 finish (satin).
 - a. Shelf: Not less than nominal **18 gauge** thick stainless steel.
 - b. Rod: Approximately **1/4-inch- (6-mm-)** diameter stainless steel.

51.7 MATERIALS

- A. Stainless Steel: ASTM A 666, Type 304, **0.031-inch (0.8-mm)** minimum nominal thickness unless otherwise indicated.
- B. Fasteners: Screws, bolts, and other devices of same material as accessory unit and tamper-and-theft resistant where exposed, and of galvanized steel where concealed.

- C. Mirrors: ASTM C 1503, Mirror Glazing Quality, clear-glass mirrors, nominal 6.0 mm thick.

51.8 FABRICATION

- A. General: Fabricate units with tight seams and joints, and exposed edges rolled. Hang doors and access panels with full-length, continuous hinges. Equip units for concealed anchorage and with corrosion-resistant backing plates.
- B. Keys: Provide universal keys for internal access to accessories for servicing and resupplying. Provide minimum of six keys to Owner's representative.

PART 52 - EXECUTION

52.1 INSTALLATION

- A. Install accessories according to manufacturers' written instructions, using fasteners appropriate to substrate indicated and recommended by unit manufacturer. Install units level, plumb, and firmly anchored in locations and at heights indicated.
- B. Grab Bars: Install to withstand a downward load of at least **250 lbf (1112 N)**, when tested according to ASTM F 446.

52.2 ADJUSTING AND CLEANING

- A. Adjust accessories for unencumbered, smooth operation. Replace damaged or defective items.
- B. Remove temporary labels and protective coatings.
- C. Clean and polish exposed surfaces according to manufacturer's written instructions.

END OF SECTION 102800

SECTION 104416
FIRE EXTINGUISHERS

PART 53 - GENERAL

53.1 RELATED DOCUMENTS

- A. Drawings and general provisions of the Contract - Standard Specifications for Public Works Construction 'The GREENBOOK' and City Supplement 'The WHITEBOOK', latest editions, including Supplemental Supplementary Provisions (SSPs), apply to this Section.

53.2 SUMMARY

- A. Section includes portable, hand-carried fire extinguishers and mounting brackets for fire extinguishers.

53.3 ACTION SUBMITTALS

- A. Product Data: For each type of product. Include rating and classification, material descriptions, dimensions of individual components and profiles, and finishes for fire extinguisher and mounting brackets.

53.4 INFORMATIONAL SUBMITTALS

- A. Warranty: Sample of special warranty.

53.5 CLOSEOUT SUBMITTALS

- A. Operation and Maintenance Data: For fire extinguishers to include in maintenance manuals.

53.6 WARRANTY

- A. Special Warranty: Manufacturer's standard form in which manufacturer agrees to repair or replace fire extinguishers that fail in materials or workmanship within specified warranty period.
 - 1. Failures include, but are not limited to, the following:
 - a. Failure of hydrostatic test according to NFPA 10.
 - b. Faulty operation of valves or release levers.
 - 2. Warranty Period: Six years from date of Substantial Completion.

53.7 REGULATORY REQUIREMENTS

A. Fire Extinguisher Cabinets:

1. Fire Extinguisher Cabinets must comply with CBC Sections 11B-307, 11B-308, 11B-309, and 11B-403.

PART 54 - PRODUCTS

54.1 PERFORMANCE REQUIREMENTS

- A. NFPA Compliance: Fabricate and label fire extinguishers to comply with NFPA 10, "Portable Fire Extinguishers."
- B. Fire Extinguishers: Listed and labeled for type, rating, and classification by an independent testing agency acceptable to authorities having jurisdiction.
- C. Comply with requirements of CCR, Title 19.

54.2 PORTABLE, HAND-CARRIED FIRE EXTINGUISHERS

- A. Fire Extinguishers: Type, size, and capacity for each mounting bracket indicated.
 1. Valves: Manufacturer's standard.
 2. Handles and Levers: Stainless steel.
 3. Instruction Labels: Include pictorial marking system complying with NFPA 10, Appendix B, and bar coding for documenting fire-extinguisher location, inspections, maintenance, and recharging.
- B. Multipurpose Dry-Chemical Type in Steel Container: UL-rated 2-A:10-B:C, **5-lb (2.3-kg)** nominal capacity, with monoammonium phosphate-based dry chemical in enameled-steel container.

54.3 MOUNTING BRACKETS

- A. Mounting Brackets: Manufacturer's standard galvanized steel, designed to secure fire extinguisher to wall or structure, of sizes required for types and capacities of fire extinguishers indicated, with plated or red baked-enamel finish.
- B. Identification: Lettering complying with authorities having jurisdiction for letter style, size, spacing, and location. Locate as indicated by Architect.
 1. Identify bracket-mounted fire extinguishers with the words "FIRE EXTINGUISHER" in red letter decals applied to mounting surface.
 - a. Orientation: Vertical.

PART 55 - EXECUTION

55.1 EXAMINATION

- A. Examine fire extinguishers for proper charging and tagging.
 - 1. Remove and replace damaged, defective, or undercharged fire extinguishers.
- B. Proceed with installation only after unsatisfactory conditions have been corrected.

55.2 INSTALLATION

- A. General: Install fire extinguishers and mounting brackets in locations indicated and in compliance with requirements of authorities having jurisdiction.
 - 1. Mounting Brackets: **38 inches (1372 mm)** above finished floor to top of fire extinguisher.
- B. Mounting Brackets: Fasten mounting brackets to surfaces, square and plumb, at locations indicated.

END OF SECTION 104416

SECTION 220000 - GENERAL PLUMBING REQUIREMENTS

PART 1 - GENERAL

1.1 GENERAL REQUIREMENTS

- A. The General conditions, supplementary conditions, special Requirements, and applicable portions of Division 1 of the specification are a part of this Division and the requirements contained herein are supplementary to them.
- B. This Division is an integrated whole comprising interrelated and interdependent sections and shall be considered in its entirety in determining requirements.
- C. Refer to other sections of this Division for additional requirements or information regarding the subjects of this Section.

1.2 ABBREVIATIONS AND DEFINITIONS (as used on Division 23 Drawings and herein)

- A. This Division is abbreviated and includes incomplete sentences. Supply omitted words by inference.
- B. Symbols: "[S]" means submittals are required; "[M/O]" means Maintenance/Operating data is required; see paragraphs hereinafter.
- C. "Provide" means furnish, install and connect unless otherwise described in specific instances.
- D. "Piping" means pipes, fittings, valves and all like pipe accessories connected thereto.
- E. "Extend", "Submit", "Repair", "Abandon", "Replace", "Remove" and similar words mean that the Contractor (or his designated subcontractor) shall accomplish the action described.
- F. "Codes" or "Code" means all codes, laws, statutes, rules, regulations, ordinances, orders, decrees, and other requirements of all legally constructed authorities and public utility franchise holders having jurisdiction.
- G. "Products", "Materials" and "Equipment" are used interchangeably and mean materials, fixtures, equipment, accessories, etc.
- H. "Utility Areas" are defined as mechanical, electrical, janitorial, and similar rooms or spaces which are normally used or occupied only by custodial or maintenance personnel. "Public Areas" are defined as the rooms or spaces which are not included in the utility areas definition.
- I. "Building Boundary" includes concrete walkways immediately adjacent to the building structure.
- J. "Below Grade" means buried in the ground, unless noted otherwise.
- K. "Substantial Plumbing Completion" means all components of all systems are functioning but lacking in final adjustment.

- L. Pressure rating specified (such as for valves and the like) means design working pressure for and with references to the fluid which the device will serve.

1.3 DESCRIPTION

- A. Provide a complete and operable installation, including all labor, supervision, materials, equipment, tools, apparatus, transportation, warehousing, rigging, scaffolding and other equipment and services necessary to accomplish the work in accordance with the intent and meaning of these drawings and specifications..

1.4 RELATED WORK

- A. Coordination: Refer to Architectural, Civil, Structural, Mechanical and Electrical Drawings for the construction details and coordinate the work of this Division with that of other Divisions. Order the work of this Division so that progress will harmonize with that of other Divisions and all work will proceed expeditiously. The work of this Division shall include direct responsibility for the correct placing and connection of plumbing work in relation to the work of other Divisions.
- B. Examine other Divisions for work related to the work of this Division especially Division 23 – MECHANICAL and Division 26 - ELECTRICAL.

1.5 DRAWINGS AND SPECIFICATIONS

- A. Drawings and specifications are intended to complement each other. Where a conflict exists between the requirements of the drawings and/or the specifications, request clarification.
- B. The Architect shall interpret the drawings and the specifications, and his decision as to the true intent and meaning thereof and the quality, quantity, and sufficiency of the materials and workmanship furnished there under shall be accepted as final and conclusive.
- C. In case of conflict not clarified prior to Bidding deadline, use the most costly alternative (better quality, greater quantity, or larger size) in preparing the Bid. A clarification will be issued to the successful bidder as soon as feasible after the Award and if appropriate a deductive change order will be issued.
- D. All provisions shall be deemed mandatory except as expressly indicated as optional by the word "may" or "option."

1.6 WATER (DOMESTIC AND FIRE), SANITARY (AND STORM) SEWERS AND NATURAL GAS SERVICE

- A. Within 5 days after award of contract, notify the serving utilities that the project is under construction and apply for permanent service in the name of the Owner. Furnish pertinent load and location information to them including the required dates for permanent service. Verify service locations and conform to utility company requirements. Contractor shall pay charges for permanent service connections levied by the utilities for which he will be reimbursed by the Owner. The reimbursement shall be limited to the actual amount of the utility service charges and a copy of the billing from the utility company shall accompany the Contractor's invoice.

1.7 PERMITS AND INSPECTIONS

- A. Obtain, schedule and pay for permits, licenses, approvals, tests, and inspections required by legally constituted authorities and public utility franchise holders having jurisdiction over the work.
- B. Afford the Architect's representative every facility for evaluating the skill and competence of the mechanics and to examine the materials. Concealed work shall be reopened when so directed during his periodic visits.

1.8 CODES AND REGULATIONS

- A. By submitting a bid, Contractor is deemed to represent himself as competent to accomplish the work of this Division in conformance with applicable Codes. In case of conflict between the Contract documents and the Code requirements, the Codes shall take precedence. Should such conflicts appear, cease work on the parts of the contract affected and immediately notify the Architect in writing. It shall be the Contractor's responsibility to correct, at no cost to the Owner, any work he executes in violation of Code requirements. Specify references to codes elsewhere in this Division are either to aid the Contractor in locating applicable information or to deny him permission to use options which are permitted by Codes.
- B. Applicable Codes: (Current editions unless otherwise noted)
 - 1. All local codes; city and/or County as applicable
 - 2. OSHA requirements
 - 3. Uniform Building Code
 - 4. Uniform Mechanical Code
 - 5. Uniform Plumbing Code
 - 6. California Building Code
 - 7. California Mechanical Code
 - 8. California Plumbing Code
 - 9. California Code of Regulations (CCR) Titles
 - 10. Fire Marshal Regulations
 - 11. Regulations of all other authorities having jurisdiction.
- C. Where conflict or variation exists among codes, the most stringent shall govern.
- D. Certificates of Conformance or Compliance: Submit original and not pre-printed certifications. Do not make statements in the certifications that could be interpreted to imply that the product does not meet all requirements specified, such as "as good as", "achieve the same end use and results as materials formulated in accordance with the referenced publications", "equal or exceed the services and performance of the specified material". Simply state that the product conforms to the requirements specified.
- E. Certified Test Reports: Certified Test Reports are reports of tests conducted on previously manufactured materials or equipment identical to that proposed for use. Before delivery of materials and equipment, submit certified copies of test reports specified in the individual sections.

- F. Factory Tests: Factory tests are tests which are required to be performed on the actual materials or equipment proposed for use. Submit results of the tests in accordance with the requirements for laboratory test results of this Contract.
- G. Permits and Certificates of Inspection: Furnish the originals.
- H. Testing procedures and test results required in this and other sections. Furnish 2 copies.
- I. Other data required by other sections of this Division. Furnish 2 copies.

1.9 RECORD AND DOCUMENTATION

A. Accumulate the following and deliver to the Owner's representative prior to final acceptance of the work:

1. Record (As-Built) Drawings:

- a. Maintain in good order in the field office a complete set of prints for all work being done under Division 23. Update the drawings daily with neat and legible annotations in red ink showing the work as actually installed.
- b. The actual size, location and elevation of all buried lines, valve boxes, manholes, monuments, and stub-outs shall be accurately located and dimensioned from building walls or other permanent landmarks.
- c. Furnish the originals.

2. Operation and Maintenance Manual: Furnish an operation and maintenance manual covering the stipulated plumbing systems and equipment. Seven copies of the manual, bound in hardback binders or an approved equivalent, shall be provided to the Architect in accordance with the Division 1 section on Maintenance and Operation Manuals. Furnish one complete manual prior to the time that system or equipment tests are performed. Furnish the remaining manuals before the contract is completed. The following identification shall be inscribed on the cover:

OPERATION AND MAINTENANCE MANUAL

PROJECT TITLE.....

CONTRACTOR.....

3. Provide a table of contents. Insert tab sheets to identify discrete subjects. Instruction sheets shall be legible and easily understood, with large sheets of drawings folded in. The manual shall be complete in all respects for all materials, piping, valves, devices and equipment, controls, accessories and appurtenances stipulated. Include as a minimum the following:

- a. Updated approved materials list, shop drawings and catalog information of all items indicated by symbol "[M/O]" at titles or beginning of paragraphs.
- b. System layout showing piping, valves and controls.
- c. Wiring and control diagrams with data to explain detailed operation and control of each component.
- d. A control sequence describing start-up, operation and shutdown.
- e. Detailed description of the function of each principal component of the system.

- f. Procedure for starting.
- g. Procedure for operation.
- h. Shut-down instruction.
- i. Installation instructions.
- j. Adjustments, maintenance and overhaul instructions.
- k. Lubrication schedule including type, grade, temperature range and frequency.
- l. Safety precautions, diagrams and illustrations.
- m. Test procedures.
- n. Performance data.
- o. Parts lists, with manufacturer's names and catalog numbers.
- p. Preventive maintenance schedule.
- q. Service organization with name, address and telephone number.
- r. Valve identification chart and schedule.
- s. ASME certification

- B. **Standard Compliance:** Where equipment or materials are specified to conform with requirements of standards of recognized technical or industrial organizations such as American National Standards (ANSI), American Society of Mechanical Engineers (ASME), American Society of Heating, Refrigeration and Air Conditioning Engineers (ASHRAE), Underwriters Laboratories (UL), American Refrigeration Institute (ARI), American Gas Association (AGA), or National Electrical Manufacturer's Association (NEMA), that use a label or published listing as a method of indicating compliance, proof of such conformance shall be submitted and approved. The label or listing of the specified organization will be acceptable evidence.
- C. **Certificates of Conformance or Compliance:** Submit original and not pre-printed certifications. Do not make statements in the certifications that could be interpreted to imply that the product does not meet all requirements specified, such as "as good as", "achieve the same end use and results as materials formulated in accordance with the referenced publications", "equal or exceed the services and performance of the specified material". Simply state that the product conforms to the requirements specified.
- D. **Certified Test Reports:** Certified Test Reports are reports of tests conducted on previously manufactured materials or equipment identical to that proposed for use. Before delivery of materials and equipment, submit certified copies of test reports specified in the individual sections.
- E. **Factory Tests:** Factory tests are tests which are required to be performed on the actual materials or equipment proposed for use. Submit results of the tests in accordance with the requirements for laboratory test results of this Contract.
- F. **Permits and Certificates of Inspection:** Furnish the originals.
- G. **Testing procedures and test results** required in this and other sections. Furnish 2 copies.
- H. **Other data** required by other sections of this Division. Furnish 2 copies.

1.10 TOOLS

- A. Provide all special tools needed for proper operation and routine adjustment and maintenance of systems and equipment. Deliver tools to Owner's representative and request a receipt for same.

1.11 CONSTRUCTION COST BREAKDOWN

- A. To assist the Architect and Engineer in evaluation of the construction cost, the Contractor shall prepare and submit for review a construction cost breakdown for the major subdivisions of the plumbing work.
- B. Subdivide each item on the breakdown into two headings: labor and materials. Include overhead and profit in each entry.
- C. Cost breakdowns shall be submitted and approved prior to the first payment request. Send one copy of the breakdown directly to the Engineer and the remaining copies sent through regular channels.

PART 2 - PRODUCTS

2.1 MATERIALS AND EQUIPMENT

- A. Standard Products: Materials and equipment shall be essentially the standard cataloged products of manufacturers regularly engaged in production of such materials or equipment and shall be their latest standard designs that comply with the specification requirements. Materials and equipment shall duplicate items that have been in satisfactory commercial or industrial use at least two years prior to bid opening. Where two or more units of the same type of equipment are required, these units shall be products of a single manufacturer. The components thereof, however, are not required to be exclusively of the same manufacturer. Each major component of equipment shall have manufacturer's name, address, model, and serial number on a nameplate securely affixed in a conspicuous place. The nameplate of the distributing agent will not be acceptable.
- B. Whenever on the plans, or in these specifications, products are identified by the name of one manufacturer, it is intended that equivalent products of other manufacturers are acceptable, unless otherwise indicated, if accepted as a substitution by the Architect. Where three or more manufacturers are listed as "acceptable manufacturers" however, then the products furnished shall be the product of one of the manufacturers listed. Manufacturers listed as "acceptable manufacturers" shall meet quality and performance of a particular one specified by both name and catalog number.

2.2 SUBSTITUTIONS

- A. General: Should the Contractor desire to substitute for specified products, he shall submit with the Material List a complete list of the requested substitutions. The request shall contain complete descriptive information of the products. Samples for evaluation shall also be submitted upon the Architect's request. If in the Architect's opinion the products as presented in this first submittal are in variance with the specified products, or if the information submitted is not sufficiently complete to allow proper evaluation, the substitution will be disallowed from consideration and the specified products shall be furnished. By proposing a substitution, it is deemed that the Contractor shall bear the cost of any changes (whether architectural, structural, electrical or mechanical) necessary to accommodate the substitution.

- B. Specific: Refer to other sections of this Division for additional requirements.

2.3 SUBMITTALS

A. General:

1. Provide for all items indicated with the symbol "[S]" at titles or beginning of paragraphs in accordance with the Division 1 section covering submittals and as herein specified. Where warranty of longer than one year is specified, include such warranty with submittal. Architect's review of the submittal is only for general conformance with design compliance with the information given in the contract documents. The submittal procedure is required as an effort to minimize the problems which occur due to the discovery of Contractor non-compliance at the construction site. The Contractor is responsible for conformation and correlation of the dimensions, quantities and sizes, for information that pertains to fabrication methods or construction techniques, and for coordination of work of all Divisions of the work. Deviations, if any, from Contract documents shall be clearly and completely indicated (by a separate letter if deviations are extensive) in the submittals, and the lack of such is deemed complete compliance with Contract Documents without any deviations. Submittals favorably processed will not relieve the Contractor of responsibility for deviations not so reported nor for errors in the submittal.
2. In addition to the above, upon permission to proceed after review of submittal and prior to the installation of work, submit dimensioned and scaled drawings (not less than 1/4-inch equal to one foot) of all mechanical equipment rooms and areas. Such layouts shall indicate, but not be limited to, all plumbing equipment, control panels, piping, housekeeping pads, ductwork, tube pull, access and maintenance clearances, and other like items. The layout shall also indicate major equipment to be provided under other Sections of work.
3. Contractor Stamp: All submittals shall be stamped with the following text and signed by the Contractors representative:

"IT IS HEREBY CERTIFIED THAT THE PRODUCTS SHOWN AND MARKED IN THIS SUBMITTAL ARE IN COMPLIANCE WITH THE CONTRACT DOCUMENTS AND CAN BE INSTALLED IN THE ALLOCATED SPACES EXCEPT WHERE NOTED AS DEVIATIONS.

CERTIFIED BY:----- DATE:-----

4. All submittals shall be complete and with catalog data and information properly marked to show, among other things, equality of material (where substitution is allowed and desired), adequacy in capacity and performance to meet minimum capacities of performance as specified or indicated. Arrange the submittals in the same sequence as these specifications, and reference (at the upper right-hand corner) the particular specification provision for which each submittal is intended. Incomplete submittals will be rejected.
5. For all work under Division 23, the notations by the Contractor or Supplier on submittal documents "Per Plans and Specifications", or "As Specified", or similar wording or phrasing is not acceptable and will be cause of rejection. Complete descriptive submittals are required for all Division 23 work.
6. Refer to the other sections of this Division for specific requirements.

- B. Material List: Within 15 days after award of Contract, submit for approval a complete list of materials proposed for use. Furnish names and addresses of manufacturers, catalog numbers (where applicable) types and trade names. For purposes of uniformity, only one manufacturer will be accepted for each class or type of material. This list is in addition to Shop Drawings.
- C. Shop Drawings: Submit shop drawings with such promptness as to cause no delay in the work. Do not commence fabrication of the equipment until the approved drawings are received from the Owner's representative.
- D. Other Submittals: As required by other sections of this Division.

PART 3 - EXECUTION

3.1 WORKMANSHIP AND INSTALLATION METHODS

- A. Workmanship shall be in the best standard practice of the trade.
- B. Execute the work so as to contribute to ease of operation and maintenance, maximum accessibility and best appearance. Execute it so that the installation will conform and adjust itself to the building structure, its equipment and its usage. The work shall be symmetrical, plumb, uniform, properly aligned, and firmly secured in place.
- C. Install equipment in accordance with the manufacturer's instructions and recommendations unless otherwise noted or specified.

3.2 TESTS

- A. General:
 - 1. Demonstrate that all components of the work of this Division have been provided and that they operate in accordance with the Contract Documents.
 - 2. Provide instruments and personnel for tests and demonstrations. Submit signed test results.
- B. Specific: Refer to the other sections of this Division for test requirements.

3.3 DELIVERY, HANDLING, STORAGE OF MATERIALS AND PROTECTION OF WORK

- A. Equipment Nameplates and Signs: Install engraved plastic-laminate equipment nameplate or s Protect materials against dirt, water, chemical and mechanical damage both while in storage and during construction.
- B. Cover materials in such a manner that no finished surfaces will be damaged, marred or splattered with plaster or paint, and all moving parts will be kept clean and dry.
- C. Replace or refinish any damaged materials including fronts of control panels, ductwork fittings, and shop fabricated ductwork.
- D. Keep cabinets and other openings closed to prevent entry of foreign matter.

3.4 CLEANUP AND HOUSEKEEPING

- A. Cleaning shall be done as the work proceeds. Periodically remove waste and debris to keep the site as clean as is practical.
- B. Leave exposed parts of the plumbing work in a neat, clean and usable condition, with painted surfaces unblemished and plated metal surfaces polished.

3.5 PROJECT CONDITIONS

1. Site Examinations and Conditions:

- 1. Regard information relative to existing conditions, services and structure as approximate only. Verify dimensions and locations, and be knowledgeable of all working conditions before submitting Bid. Verify pressure, location, size, and elevation of existing services (to which points of connection are to be made or crossed) as soon as possible and prior to commencement of any new work.
 - 2. Make minor deviations necessary to conform to actual locations and conditions. Submission of Bid presumes proper examination of Site, locations, dimensions and conditions, and no additional cost will be honored for lack of such examinations.
- B. Existing Services: Examine the Contract Drawings and visit the project site to ascertain the extent of the existing services. Where existing equipment/services serving existing structures and/or existing structures to be demolished are to remain in service, reroute, relocate, or extend such existing equipment and/or services to accommodate this project without additional cost.
- C. Interruption of Existing Services: Where it is necessary to reroute existing services or utilities, or to make connections of new work to existing services or utilities, give timely written notice of such intent to the Owner and secure written approval before proceeding. Make all such interruptions at such time as permitted by the Owner. Anticipate such interruptions to be made outside of normal working hours or normal working days; therefore, no additional cost will be permitted for such work. Except in a case of emergency involving life, limb or health, do not operate any existing equipment (including valves). Where such operations are necessary, they shall be performed by the Owner's personnel.
- D. Access and Placement of Work:
- 1. Check and coordinate for clearance, accessibility and placement of equipment either by going through openings provided or by placing equipment during construction. Ordering of equipment to be shipped, disassembled, or disassembly of equipment at Project Site and re-assembly of equipment to accomplish this requirement shall be executed without additional cost. Where provided openings are inadequate to accommodate equipment, provide new openings and restoration of same, all at no additional cost. Obtain written approval for new openings before proceeding.
 - 2. Verify location of all plumbing fixtures and equipment within finished spaces with the Architectural Drawings. In the event that Plumbing Drawings do not indicate exact locations, or are in conflict with the Architectural Drawings, obtain information regarding proper locations. Installation of work without proper instruction under such circumstances will result in relocation of work, when directed, without additional cost.

- E. Verification and Coordination: Drawings indicating suggested distribution routes are diagrammatic only, and all scaled and figured dimensions are approximate and are indicated for estimating purposes only. The Drawings do not indicate necessary offsets and like items. Do not construe Contract Drawings as fabrication drawings. Prior to fabrication and installation of work, verify all dimensions, sizes and distribution routes with actual conditions, and prepare submittal and fabrication drawings. Coordinate to avoid possible conflicts and resolve same where such exist. Install work to conform to structure, avoid obstruction, preserve headroom, and keep openings and passageway clear. Changes necessary, resulting from such verification and coordination, shall not be a cause for additional cost.
- F. See Drawings for extent of demolition.

3.6 WARRANTY

- A. Guarantee, in writing, all work against fault of any product or workmanship for a period of not less than one year after formal acceptance by the Owner; except, where longer periods are specified in the Specifications, such longer periods shall govern. However, when any component fails at any time during this period, the warranty period for such component and all other components that are inactive because of said failure shall be suspended. The warranty period for such component shall resume running for the remaining portion of the warranty period when failed component is completely repaired and in operation; however, in no case shall the resumed portion of the warranty period be less than 3 months in duration.
- B. Neither payments for work, nor total or partial occupancy of work by the Owner, within or prior to the warranty period specified, shall be construed as acceptance of faulty work or shall condone any negligence or omission of Contractor in doing the work.

3.7 SAFETY REQUIREMENTS

- A. Enclose and guard belts, pulleys, chains, gears, couplings, projecting setscrews, keys and other rotating parts in accordance with the OSHA 1910.219. Insulate, guard, and cover any high-temperature equipment and piping so located as to endanger personnel or create a fire hazard.

3.8 MANUFACTURER'S RECOMMENDATIONS

- A. Where installation procedures or any part thereof are required to be in accordance with the recommendations of the manufacturer of the material or equipment being installed, furnish printed copies of these recommendations to the installing Contractor and Architect prior to installation. Do not proceed with the installation of the item until the recommendations are received. Failure to furnish these recommendations can be cause for rejection of the material.

END OF SECTION

SECTION 220513 - COMMON MOTOR REQUIREMENTS FOR PLUMBING EQUIPMENT

PART 5 - GENERAL

5.1 RELATED DOCUMENTS

- A. Drawings and general provisions of the Contract, including General and Supplementary Conditions and Division 01 Specification Sections, apply to this Section.

5.2 SUMMARY

- A. Section includes general requirements for single-phase and polyphase, general-purpose, horizontal, small and medium, squirrel-cage induction motors for use on ac power systems up to 600 V and installed at equipment manufacturer's factory or shipped separately by equipment manufacturer for field installation.

5.3 COORDINATION

- A. Coordinate features of motors, installed units, and accessory devices to be compatible with the following:
 - 1. Motor controllers.
 - 2. Torque, speed, and horsepower requirements of the load.
 - 3. Ratings and characteristics of supply circuit and required control sequence.
 - 4. Ambient and environmental conditions of installation location.

PART 6 - PRODUCTS

6.1 GENERAL MOTOR REQUIREMENTS

- A. Comply with requirements in this Section except when stricter requirements are specified in plumbing equipment schedules or Sections.
- B. Comply with NEMA MG 1 unless otherwise indicated.
- C. Comply with IEEE 841 for severe-duty motors.

6.2 MOTOR CHARACTERISTICS

- A. Duty: Continuous duty at ambient temperature of 40 deg C and at altitude of **3300 feet (1000 m)** above sea level.
- B. Capacity and Torque Characteristics: Sufficient to start, accelerate, and operate connected loads at designated speeds, at installed altitude and environment, with indicated operating sequence, and without exceeding nameplate ratings or considering service factor.

6.3 POLYPHASE MOTORS

- A. Description: NEMA MG 1, Design B, medium induction motor.
- B. Efficiency: Energy efficient, as defined in NEMA MG 1.
- C. Service Factor: 1.15.
- D. Multispeed Motors: Variable torque.
 - 1. For motors with 2:1 speed ratio, consequent pole, single winding.
 - 2. For motors with other than 2:1 speed ratio, separate winding for each speed.
- E. Multispeed Motors: Separate winding for each speed.
- F. Rotor: Random-wound, squirrel cage.
- G. Bearings: Regreasable, shielded, antifriction ball bearings suitable for radial and thrust loading.
- H. Temperature Rise: Match insulation rating.
- I. Insulation: Class F
- J. Code Letter Designation:
 - 1. Motors 15 HP and Larger: NEMA starting Code F or Code G.
 - 2. Motors Smaller than 15 HP: Manufacturer's standard starting characteristic.
- K. Enclosure Material: Cast iron for motor frame sizes 324T and larger; rolled steel for motor frame sizes smaller than 324T.

6.4 POLYPHASE MOTORS WITH ADDITIONAL REQUIREMENTS

- A. Motors Used with Reduced-Voltage and Multispeed Controllers: Match wiring connection requirements for controller with required motor leads. Provide terminals in motor terminal box, suited to control method.
- B. Motors Used with Variable Frequency Controllers: Ratings, characteristics, and features coordinated with and approved by controller manufacturer.
 - 1. Windings: Copper magnet wire with moisture-resistant insulation varnish, designed and tested to resist transient spikes, high frequencies, and short time rise pulses produced by pulse-width modulated inverters.
 - 2. Energy- and Premium-Efficient Motors: Class B temperature rise; Class F insulation.
 - 3. Inverter-Duty Motors: Class F temperature rise; Class H insulation.
 - 4. Thermal Protection: Comply with NEMA MG 1 requirements for thermally protected motors.
- C. Severe-Duty Motors: Comply with IEEE 841, with 1.15 minimum service factor.

6.5 SINGLE-PHASE MOTORS

- A. Motors larger than 1/20 hp shall be one of the following, to suit starting torque and requirements of specific motor application:
 - 1. Permanent-split capacitor.
 - 2. Split phase.
 - 3. Capacitor start, inductor run.
 - 4. Capacitor start, capacitor run.
- B. Multispeed Motors: Variable-torque, permanent-split-capacitor type.
- C. Bearings: Prelubricated, antifriction ball bearings or sleeve bearings suitable for radial and thrust loading.
- D. Motors 1/20 HP and Smaller: Shaded-pole type.
- E. Thermal Protection: Internal protection to automatically open power supply circuit to motor when winding temperature exceeds a safe value calibrated to temperature rating of motor insulation. Thermal-protection device shall automatically reset when motor temperature returns to normal range.

PART 7 - EXECUTION (Not Applicable)

END OF SECTION

SECTION 220517 - SLEEVES AND SLEEVE SEALS FOR PLUMBING PIPING

PART 9 - GENERAL

9.1 RELATED DOCUMENTS

- A. Drawings and general provisions of the Contract, including General and Supplementary Conditions and Division 01 Specification Sections, apply to this Section.

9.2 SUMMARY

- A. Section Includes:
 - 1. Sleeves.
 - 2. Stack-sleeve fittings.
 - 3. Sleeve-seal systems.
 - 4. Sleeve-seal fittings.
 - 5. Grout.

9.3 SUBMITTALS

- A. Product Data: For each type of product indicated.

PART 10 - PRODUCTS

10.1 SLEEVES

- A. Cast-Iron Wall Pipes: Cast or fabricated of cast or ductile iron and equivalent to ductile-iron pressure pipe, with plain ends and integral waterstop unless otherwise indicated.
- B. Galvanized-Steel Wall Pipes: ASTM A 53/A 53M, Schedule 40, with plain ends and welded steel collar; zinc coated.
- C. Galvanized-Steel-Pipe Sleeves: ASTM A 53/A 53M, Type E, Grade B, Schedule 40, zinc coated, with plain ends.
- D. PVC-Pipe Sleeves: ASTM D 1785, Schedule 40.
- E. Galvanized-Steel-Sheet Sleeves: 0.0239-inch (0.6-mm) minimum thickness; round tube closed with welded longitudinal joint.
- F. Molded-PE or -PP Sleeves: Removable, tapered-cup shaped, and smooth outer surface with nailing flange for attaching to wooden forms.
- G. Molded-PVC Sleeves: With nailing flange for attaching to wooden forms.

10.2 STACK-SLEEVE FITTINGS

- A. Manufacturers: Subject to compliance with requirements, provide products by one of the following:
 - 1. Smith, Jay R. Mfg. Co.
 - 2. Zurn Specification Drainage Operation; Zurn Plumbing Products Group.
- B. Description: Manufactured, cast-iron sleeve with integral clamping flange. Include clamping ring, bolts, and nuts for membrane flashing.
 - 1. Underdeck Clamp: Clamping ring with setscrews.

10.3 SLEEVE-SEAL SYSTEMS

- A. Manufacturers: Subject to compliance with requirements, provide products by one of the following:
 - 1. Advance Products & Systems, Inc.
 - 2. CALPICO, Inc.
 - 3. Metraflex Company (The).
 - 4. Pipeline Seal and Insulator, Inc.
 - 5. Proco Products, Inc.
- B. Description: Modular sealing-element unit, designed for field assembly, for filling annular space between piping and sleeve.
 - 1. Sealing Elements: EPDM-rubber interlocking links shaped to fit surface of pipe. Include type and number required for pipe material and size of pipe.
 - 2. Pressure Plates: Carbon steel
 - 3. Connecting Bolts and Nuts: Carbon steel, with corrosion-resistant coating, of length required to secure pressure plates to sealing elements.

10.4 SLEEVE-SEAL FITTINGS

- A. Manufacturers: Subject to compliance with requirements, provide products by one of the following:
 - 1. Presealed Systems.
- B. Description: Manufactured plastic, sleeve-type, waterstop assembly made for imbedding in concrete slab or wall. Unit has plastic or rubber waterstop collar with center opening to match piping OD.

10.5 GROUT

- A. Standard: ASTM C 1107/C 1107M, Grade B, post-hardening and volume-adjusting, dry, hydraulic-cement grout.
- B. Characteristics: Nonshrink; recommended for interior and exterior applications.

- C. Design Mix: 5000-psi (34.5-MPa), 28-day compressive strength.
- D. Packaging: Premixed and factory packaged.

PART 11 - EXECUTION

11.1 SLEEVE INSTALLATION

- A. Install sleeves for piping passing through penetrations in floors, partitions, roofs, and walls.
- B. For sleeves that will have sleeve-seal system installed, select sleeves of size large enough to provide 1-inch (25-mm) annular clear space between piping and concrete slabs and walls.
 - 1. Sleeves are not required for core-drilled holes.
- C. Install sleeves in concrete floors, concrete roof slabs, and concrete walls as new slabs and walls are constructed.
 - 1. Permanent sleeves are not required for holes in slabs formed by molded-PE or -PP sleeves.
 - 2. Cut sleeves to length for mounting flush with both surfaces.
 - a. Exception: Extend sleeves installed in floors of mechanical equipment areas or other wet areas 2 inches (50 mm) above finished floor level.
 - 3. Using grout, seal the space outside of sleeves in slabs and walls without sleeve-seal system.
- D. Install sleeves for pipes passing through interior partitions.
 - 1. Cut sleeves to length for mounting flush with both surfaces.
 - 2. Install sleeves that are large enough to provide 1/4-inch (6.4-mm) annular clear space between sleeve and pipe or pipe insulation.
 - 3. Seal annular space between sleeve and piping or piping insulation; use joint sealants appropriate for size, depth, and location of joint. Comply with requirements for sealants specified in Division 07 Section "Joint Sealants."
- E. Fire-Barrier Penetrations: Maintain indicated fire rating of walls, partitions, ceilings, and floors at pipe penetrations. Seal pipe penetrations with firestop materials.

11.2 STACK-SLEEVE-FITTING INSTALLATION

- A. Install stack-sleeve fittings in new slabs as slabs are constructed.
 - 1. Install fittings that are large enough to provide 1/4-inch (6.4-mm) annular clear space between sleeve and pipe or pipe insulation.
 - 2. Secure flashing between clamping flanges for pipes penetrating floors with membrane waterproofing. Comply with requirements for flashing specified in Division 07 Section "Sheet Metal Flashing and Trim."

3. Install section of cast-iron soil pipe to extend sleeve to **2 inches (50 mm)** above finished floor level.
 4. Extend cast-iron sleeve fittings below floor slab as required to secure clamping ring if ring is specified.
 5. Using grout, seal the space around outside of stack-sleeve fittings.
- B. Fire-Barrier Penetrations: Maintain indicated fire rating of floors at pipe penetrations. Seal pipe penetrations with firestop materials.

11.3 SLEEVE-SEAL-SYSTEM INSTALLATION

- A. Install sleeve-seal systems in sleeves in exterior concrete walls and slabs-on-grade at service piping entries into building.
- B. Select type, size, and number of sealing elements required for piping material and size and for sleeve ID or hole size. Position piping in center of sleeve. Center piping in penetration, assemble sleeve-seal system components, and install in annular space between piping and sleeve. Tighten bolts against pressure plates that cause sealing elements to expand and make a watertight seal.

11.4 SLEEVE-SEAL-FITTING INSTALLATION

- A. Install sleeve-seal fittings in new walls and slabs as they are constructed.
- B. Assemble fitting components of length to be flush with both surfaces of concrete slabs and walls. Position waterstop flange to be centered in concrete slab or wall.
- C. Secure nailing flanges to concrete forms.
- D. Using grout, seal the space around outside of sleeve-seal fittings.

11.5 SLEEVE AND SLEEVE-SEAL SCHEDULE

- A. Use sleeves and sleeve seals for the following piping-penetration applications:
 1. Exterior Concrete Walls above Grade:
 - a. Piping Smaller Than **NPS 6 (DN 150)** Cast-iron wall sleeves
 - b. Piping **NPS 6 (DN 150)** and Larger: Cast-iron wall sleeves
 2. Concrete Slabs-on-Grade:
 - a. Piping Smaller Than **NPS 6 (DN 150)**: Cast-iron wall sleeves with sleeve-seal system
 - 1) Select sleeve size to allow for **1-inch (25-mm)** annular clear space between piping and sleeve for installing sleeve-seal system.
 - b. Piping **NPS 6 (DN 150)** and Larger: Cast-iron wall sleeves with sleeve-seal system

- 1) Select sleeve size to allow for 1-inch (25-mm) annular clear space between piping and sleeve for installing sleeve-seal system.
3. Interior Partitions:
 - a. Piping Smaller Than NPS 6 (DN 150) Galvanized-steel-pipe sleeves.
 - b. Piping NPS 6 (DN 150) and Larger: Galvanized-steel-sheet sleeves.

END OF SECTION

SECTION 220518 - ESCUTCHEONS FOR PLUMBING PIPING

PART 13 - GENERAL

13.1 RELATED DOCUMENTS

- A. Drawings and general provisions of the Contract, including General and Supplementary Conditions and Division 01 Specification Sections, apply to this Section.

13.2 SUMMARY

- A. Section Includes:
 - 1. Escutcheons.
 - 2. Floor plates.

13.3 SUBMITTALS

- A. Product Data: For each type of product indicated.

PART 14 - PRODUCTS

14.1 ESCUTCHEONS

- A. One-Piece, Cast-Brass Type: With polished, chrome-plated and rough-brass finish and setscrew fastener.
- B. One-Piece, Deep-Pattern Type: Deep-drawn, box-shaped brass with chrome-plated finish and spring-clip fasteners.
- C. One-Piece, Stamped-Steel Type: With chrome-plated finish and spring-clip fasteners.
- D. Split-Casting Brass Type: With polished, chrome-plated and rough-brass finish and with concealed hinge and setscrew.
- E. Split-Plate, Stamped-Steel Type: With chrome-plated finish, concealed hinge, and spring-clip fasteners.

14.2 FLOOR PLATES

- A. One-Piece Floor Plates: Cast-iron flange.
- B. Split-Casting Floor Plates: Cast brass with concealed hinge.

PART 15 - EXECUTION

15.1 INSTALLATION

- A. Install escutcheons for piping penetrations of walls, ceilings, and finished floors.

B. Install escutcheons with ID to closely fit around pipe, tube, and insulation of insulated piping and with OD that completely covers opening.

1. Escutcheons for New Piping:

- a. Piping with Fitting or Sleeve Protruding from Wall: One-piece, deep-pattern type.
- b. Chrome-Plated Piping: One-piece, cast-brass type with polished, chrome-plated finish.
- c. Insulated Piping: One-piece, stamped-steel type
- d. Bare Piping at Wall and Floor Penetrations in Finished Spaces: One-piece, cast-brass type with polished, chrome-plated finish.
- e. Bare Piping at Wall and Floor Penetrations in Finished Spaces: One-piece, stamped-steel type
- f. Bare Piping at Ceiling Penetrations in Finished Spaces: One-piece, cast-brass type with polished, chrome-plated finish.
- g. Bare Piping at Ceiling Penetrations in Finished Spaces: One-piece, stamped-steel type.
- h. Bare Piping in Unfinished Service Spaces: One-piece, cast-brass type with rough-brass finish.
- i. Bare Piping in Unfinished Service Spaces: One-piece, stamped-steel type or split-plate, stamped-steel type with concealed hinge.
- j. Bare Piping in Equipment Rooms: One-piece, cast-brass type with rough-brass finish.
- k. Bare Piping in Equipment Rooms: One-piece, stamped-steel type or split-plate, stamped-steel type with concealed hinge

2. Escutcheons for Existing Piping:

- a. Chrome-Plated Piping: Split-casting brass type with polished, chrome-plated finish.
- b. Insulated Piping: Split-plate, stamped-steel type with concealed hinge.
- c. Bare Piping at Wall and Floor Penetrations in Finished Spaces: Split-casting brass type with polished, chrome-plated finish.
- d. Bare Piping at Wall and Floor Penetrations in Finished Spaces: Split-plate, stamped-steel type with concealed hinge.
- e. Bare Piping at Ceiling Penetrations in Finished Spaces: Split-casting brass type with polished, chrome-plated finish.
- f. Bare Piping at Ceiling Penetrations in Finished Spaces: Split-plate, stamped-steel type with concealed hinge.
- g. Bare Piping in Unfinished Service Spaces: Split-casting brass type with rough-brass finish.
- h. Bare Piping in Unfinished Service Spaces: Split-plate, stamped-steel type with concealed or exposed-rivet hinge.
- i. Bare Piping in Equipment Rooms: Split-casting brass type with rough-brass finish.
- j. Bare Piping in Equipment Rooms: Split-plate, stamped-steel type with concealed or exposed-rivet hinge.

C. Install floor plates for piping penetrations of equipment-room floors.

D. Install floor plates with ID to closely fit around pipe, tube, and insulation of piping and with OD that completely covers opening.

1. New Piping: One-piece, floor-plate type.
2. Existing Piping: Split-casting, floor-plate type.

15.2 FIELD QUALITY CONTROL

- A. Replace broken and damaged escutcheons and floor plates using new materials.

END OF SECTION

SECTION 220519 - METERS AND GAGES FOR PLUMBING PIPING

PART 17 - GENERAL

17.1 RELATED DOCUMENTS

- A. Drawings and general provisions of the Contract, including General and Supplementary Conditions and Division 01 Specification Sections, apply to this Section.

17.2 SUMMARY

- A. Section Includes:

1. Bimetallic-actuated thermometers.
2. Filled-system thermometers.
3. Liquid-in-glass thermometers.
4. Thermowells.
5. Dial-type pressure gages.
6. Gage attachments.
7. Test plugs.
8. Test-plug kits.
9. Sight flow indicators.

- B. Related Sections:

1. Division 22 Section "Domestic Water Piping" for water meters inside the building.

17.3 SUBMITTALS

- A. Product Data: For each type of product indicated.
- B. Product Certificates: For each type of meter and gage, from manufacturer.
- C. Operation and Maintenance Data: For meters and gages to include in operation and maintenance manuals.

PART 18 - PRODUCTS

18.1 BIMETALLIC-ACTUATED THERMOMETERS

- A. Manufacturers: Subject to compliance with requirements, provide products by one of the following:

1. Ashcroft Inc.
2. Ernst Flow Industries.
3. Marsh Bellofram.
4. Miljoco Corporation.
5. Nanmac Corporation.
6. Noshok.
7. Palmer Wahl Instrumentation Group.
8. REOTEMP Instrument Corporation.
9. Tel-Tru Manufacturing Company.
10. Terice, H. O. Co.
11. Watts Regulator Co.; a div. of Watts Water Technologies, Inc.
12. Weiss Instruments, Inc.
13. WIKA Instrument Corporation - USA.
14. Winters Instruments - U.S.

B. Standard: ASME B40.200.

C. Case: Liquid-filled and sealed type(s); stainless steel with 3-inch (76-mm) nominal diameter.

D. Dial: Nonreflective aluminum with permanently etched scale markings and scales in deg F and deg C.

E. Connector Type(s): Union joint, adjustable angle with unified-inch screw threads.

F. Connector Size: 1/2 inch (13 mm), with ASME B1.1 screw threads.

G. Stem: 0.25 or 0.375 inch (6.4 or 9.4 mm) in diameter; stainless steel.

H. Window: Glass or plastic

I. Ring: Stainless steel.

J. Element: Bimetal coil.

K. Pointer: Dark-colored metal.

L. Accuracy: Plus or minus 1 percent of scale range.

18.2 FILLED-SYSTEM THERMOMETERS

A. Direct-Mounted, Metal-Case, Vapor-Actuated Thermometers:

1. Manufacturers: Subject to compliance with requirements, provide products by one of the following:
 - a. Ashcroft Inc.
 - b. Marsh Bellofram.
 - c. Miljoco Corporation.
 - d. Palmer Wahl Instrumentation Group.
 - e. REOTEMP Instrument Corporation.
 - f. Terice, H. O. Co.
 - g. Weiss Instruments, Inc.

2. Standard: ASME B40.200.
3. Case: Sealed type, cast aluminum or drawn steel; 4-1/2-inch (114-mm) nominal diameter.
4. Element: Bourdon tube or other type of pressure element.
5. Movement: Mechanical with link to pressure element and connection to pointer.
6. Dial: Nonreflective aluminum with permanently etched scale markings graduated in deg F and deg C.
7. Pointer: Dark-colored metal.
8. Window: Glass or plastic.
9. Ring: Stainless steel.
10. Connector Type(s): Union joint, adjustable, 180 degrees in vertical plane, 360 degrees in horizontal plane, with locking device with ASME B1.1 screw threads.
11. Thermal System: Liquid-filled bulb in copper-plated steel, aluminum, or brass stem and of length to suit installation.
 - a. Design for Thermowell Installation: Bare stem.
12. Accuracy: Plus or minus 1 percent of scale range.

B. Direct-Mounted, Plastic-Case, Vapor-Actuated Thermometers:

1. Manufacturers: Subject to compliance with requirements, provide products by one of the following:
 - a. Ashcroft Inc.
 - b. Miljoco Corporation.
 - c. REOTEMP Instrument Corporation.
2. Standard: ASME B40.200.
3. Case: Sealed type, plastic 4-1/2-inch (114-mm) nominal diameter.
4. Element: Bourdon tube or other type of pressure element.
5. Movement: Mechanical, with link to pressure element and connection to pointer.
6. Dial: Nonreflective aluminum with permanently etched scale markings graduated in deg F and deg C.
7. Pointer: Dark-colored metal.
8. Window: Glass or plastic.
9. Ring: Metal or plastic.
10. Connector Type(s): Union joint, adjustable, 180 degrees in vertical plane, 360 degrees in horizontal plane, with locking device with ASME B1.1 screw threads.
11. Thermal System: Liquid-filled bulb in copper-plated steel, aluminum, or brass stem and of length to suit installation.
 - a. Design for Thermowell Installation: Bare stem.
12. Accuracy: Plus or minus 1 percent of scale range.

C. Remote-Mounted, Metal-Case, Vapor-Actuated Thermometers:

1. Manufacturers: Subject to compliance with requirements, provide products by one of the following:
 - a. AMETEK, Inc.; U.S. Gauge.
 - b. Ashcroft Inc.

- c. Marsh Bellofram.
 - d. Miljoco Corporation.
 - e. Palmer Wahl Instrumentation Group.
 - f. REOTEMP Instrument Corporation.
 - g. Trerice, H. O. Co.
 - h. Weiss Instruments, Inc.
 - i. WIKA Instrument Corporation - USA.
2. Standard: ASME B40.200.
 3. Case: Sealed type, cast aluminum or drawn steel 4-1/2-inch (114-mm) nominal diameter with back flange and holes for panel mounting.
 4. Element: Bourdon tube or other type of pressure element.
 5. Movement: Mechanical, with link to pressure element and connection to pointer.
 6. Dial: Nonreflective aluminum with permanently etched scale markings graduated in deg F and deg C.
 7. Pointer: Dark-colored metal.
 8. Window: Glass or plastic.
 9. Ring: Metal
 10. Connector Type(s): Union joint, bottom; with ASME B1.1 screw threads.
 11. Thermal System: Liquid-filled bulb in copper-plated steel, aluminum, or brass stem and of length to suit installation.
 - a. Design for Thermowell Installation: Bare stem.
 12. Accuracy: Plus or minus 1 percent of scale range.

18.3 THERMOWELLS

A. Thermowells:

1. Standard: ASME B40.200.
2. Description: Pressure-tight, socket-type fitting made for insertion into piping tee fitting.
3. Material for Use with Copper Tubing: CNR or CUNI
4. Material for Use with Steel Piping: CSA.
5. Type: Stepped shank unless straight or tapered shank is indicated.
6. External Threads: NPS 1/2, NPS 3/4, or NPS 1, (DN 15, DN 20, or NPS 25,) ASME B1.20.1 pipe threads.
7. Internal Threads: 1/2, 3/4, and 1 inch (13, 19, and 25 mm), with ASME B1.1 screw threads.
8. Bore: Diameter required to match thermometer bulb or stem.
9. Insertion Length: Length required to match thermometer bulb or stem.
10. Lagging Extension: Include on thermowells for insulated piping and tubing.
11. Bushings: For converting size of thermowell's internal screw thread to size of thermometer connection.

B. Heat-Transfer Medium: Mixture of graphite and glycerin.

18.4 PRESSURE GAGES

A. Direct-Mounted, Metal-Case, Dial-Type Pressure Gages:

1. Manufacturers: Subject to compliance with requirements, provide products by one of the following:
 - a. Ashcroft Inc.
 - b. Ernst Flow Industries.
 - c. Flo Fab Inc.
 - d. Marsh Bellofram.
 - e. Miljoco Corporation.
 - f. Noshok.
 - g. Palmer Wahl Instrumentation Group.
 - h. REOTEMP Instrument Corporation.
 - i. Tel-Tru Manufacturing Company.
 - j. Trerice, H. O. Co.
 - k. Watts Regulator Co.; a div. of Watts Water Technologies, Inc.
 - l. Weiss Instruments, Inc.
 - m. WIKA Instrument Corporation - USA.
 - n. Winters Instruments - U.S.
2. Standard: ASME B40.100.
3. Case: Sealed type(s); cast aluminum or drawn steel; 4-1/2-inch (114-mm) [6-inch (152-mm) nominal diameter.
4. Pressure-Element Assembly: Bourdon tube unless otherwise indicated.
5. Pressure Connection: Brass, with NPS 1/4 or NPS 1/2 (DN 8 or DN 15) ASME B1.20.1 pipe threads and bottom-outlet type unless back-outlet type is indicated.
6. Movement: Mechanical, with link to pressure element and connection to pointer.
7. Dial: Nonreflective aluminum with permanently etched scale markings graduated in psi (kPa)
8. Pointer: Dark-colored metal.
9. Window: Glass or plastic.
10. Ring: Stainless steel.
11. Accuracy: Grade A, plus or minus 1 percent of middle half of scale range.

18.5 GAGE ATTACHMENTS

- A. Snubbers: ASME B40.100, brass; with NPS 1/4 or NPS 1/2 (DN 8 or DN 15), ASME B1.20.1 pipe threads and piston type surge-dampening device. Include extension for use on insulated piping.
- B. Valves: Brass or stainless-steel needle, with NPS 1/4 or NPS 1/2 (DN 8 or DN 15), ASME B1.20.1 pipe threads.

18.6 TEST PLUGS

- A. Manufacturers: Subject to compliance with requirements, provide products by one of the following:
 1. Flow Design, Inc.
 2. Miljoco Corporation.
 3. National Meter, Inc.
 4. Peterson Equipment Co., Inc.

5. Sisco Manufacturing Company, Inc.
6. Trerice, H. O. Co.
7. Watts Regulator Co.; a div. of Watts Water Technologies, Inc.
8. Weiss Instruments, Inc.

- B. Description: Test-station fitting made for insertion into piping tee fitting.
- C. Body: Brass or stainless steel with core inserts and gasketed and threaded cap. Include extended stem on units to be installed in insulated piping.
- D. Thread Size: **NPS 1/4 (DN 8)** or **NPS 1/2 (DN 15)**, ASME B1.20.1 pipe thread.
- E. Minimum Pressure and Temperature Rating: **500 psig at 200 deg F (3450 kPa at 93 deg C)**.
- F. Core Inserts: EPDM self-sealing rubber.

18.7 TEST-PLUG KITS

- A. Manufacturers: Subject to compliance with requirements, provide products by one of the following:
 1. Flow Design, Inc.
 2. Miljoco Corporation.
 3. National Meter, Inc.
 4. Peterson Equipment Co., Inc.
 5. Sisco Manufacturing Company, Inc.
 6. Trerice, H. O. Co.
 7. Watts Regulator Co.; a div. of Watts Water Technologies, Inc.
 8. Weiss Instruments, Inc.
- B. Furnish one test-plug kit(s) containing one thermometer(s), one pressure gage and adapter, and carrying case. Thermometer sensing elements, pressure gage, and adapter probes shall be of diameter to fit test plugs and of length to project into piping.
- C. Low-Range Thermometer: Small, bimetallic insertion type with **1- to 2-inch- (25- to 51-mm-)** diameter dial and tapered-end sensing element. Dial range shall be at least **25 to 125 deg F (minus 4 to plus 52 deg C)**
- D. High-Range Thermometer: Small, bimetallic insertion type with **1- to 2-inch- (25- to 51-mm-)** diameter dial and tapered-end sensing element. Dial range shall be at least **0 to 220 deg F (minus 18 to plus 104 deg C)**
- E. Pressure Gage: Small, Bourdon-tube insertion type with **2- to 3-inch- (51- to 76-mm-)** diameter dial and probe. Dial range shall be at least **0 to 200 psig (0 to 1380 kPa)**
- F. Carrying Case: Metal or plastic, with formed instrument padding.

18.8 SIGHT FLOW INDICATORS

- A. Manufacturers: Subject to compliance with requirements, provide products by one of the following:

1. Archon Industries, Inc.
 2. Dwyer Instruments, Inc.
 3. Emerson Process Management; Brooks Instrument.
 4. Ernst Co., John C., Inc.
 5. Ernst Flow Industries.
 6. KOBOLD Instruments, Inc. - USA; KOBOLD Messring GmbH.
 7. OPW Engineered Systems; a Dover company.
 8. Penberthy; A Brand of Tyco Valves & Controls - Prophetstown.
- B. Description: Piping inline-installation device for visual verification of flow.
- C. Construction: Bronze or stainless-steel body, with sight glass and ball, flapper, or paddle wheel indicator, and threaded or flanged ends.
- D. Minimum Pressure Rating: 150 psig (1034 kPa)
- E. Minimum Temperature Rating: 200 deg F (93 deg C)
- F. End Connections for NPS 2 (DN 50) and Smaller: Threaded.
- G. End Connections for NPS 2-1/2 (DN 65) and Larger: Flanged.

PART 19 - EXECUTION

19.1 INSTALLATION

- A. Install thermowells with socket extending a minimum of one-third of pipe diameter and in vertical position in piping tees.
- B. Install thermowells of sizes required to match thermometer connectors. Include bushings if required to match sizes.
- C. Install thermowells with extension on insulated piping.
- D. Fill thermowells with heat-transfer medium.
- E. Install direct-mounted thermometers in thermowells and adjust vertical and tilted positions.
- F. Install remote-mounted thermometer bulbs in thermowells and install cases on panels; connect cases with tubing and support tubing to prevent kinks. Use minimum tubing length.
- G. Install direct-mounted pressure gages in piping tees with pressure gage located on pipe at the most readable position.
- H. Install remote-mounted pressure gages on panel.
- I. Install valve and snubber in piping for each pressure gage for fluids.
- J. Install test plugs in piping tees.
- K. Install thermometers in the following locations:

1. Inlet and outlet of each water heater.
2. Inlets and outlets of each domestic water heat exchanger.
3. Inlet and outlet of each domestic hot-water storage tank.
4. Inlet and outlet of each remote domestic water chiller.

L. Install pressure gages in the following locations:

1. Building water service entrance into building.
2. Inlet and outlet of each pressure-reducing valve.
3. Suction and discharge of each domestic water pump.

19.2 CONNECTIONS

A. Install meters and gages adjacent to machines and equipment to allow service and maintenance of meters, gages, machines, and equipment.

19.3 ADJUSTING

A. Adjust faces of meters and gages to proper angle for best visibility.

19.4 THERMOMETER SCHEDULE

A. Thermometers at inlet and outlet of each domestic water heater shall be [**one of**] the following:

1. Sealed, bimetallic-actuated type.
2. Direct -mounted, metal case, vapor-actuated type.
3. Compact style, liquid-in-glass type.
4. Direct mounted, light-activated type.
5. Test plug with EPDM self-sealing rubber inserts.

B. Thermometers at inlet and outlet of each domestic hot-water storage tank shall be one of the following:

1. Sealed, bimetallic-actuated type.
2. Direct mounted, metal-case, vapor-actuated type.
3. Compact style, liquid-in-glass type.
4. Direct-mounted, light-activated type.
5. Test plug with EPDM self-sealing rubber inserts.

19.5 THERMOMETER SCALE-RANGE SCHEDULE

A. Scale Range for Domestic Cold-Water Piping: **0 to 150 deg F** (Minus 20 to plus 70 deg C)

B. Scale Range for Domestic Hot-Water Piping: **30 to 240 deg F** (0 to plus 115 deg C)

19.6 PRESSURE-GAGE SCHEDULE

- A. Pressure gages at discharge of each water service into building shall be one of the following:
 - 1. Sealed, direct mounted, metal case.
 - 2. Sealed, direct mounted, plastic case.
 - 3. Test plug with EPDM self-sealing rubber inserts.

- B. Pressure gages at inlet and outlet of each water pressure-reducing valve shall be one of the following:
 - 1. Sealed direct mounted, metal case.
 - 2. Sealed direct mounted, plastic case.
 - 3. Test plug with EPDM self-sealing rubber inserts.

- C. Pressure gages at suction and discharge of each domestic water pump shall be one of the following:
 - 1. Sealed direct-mounted, metal case.
 - 2. Sealed, direct -mounted, plastic case.
 - 3. Test plug with EPDM self-sealing rubber inserts.

19.7 PRESSURE-GAGE SCALE-RANGE SCHEDULE

- A. Scale Range for Water Service Piping: [0 to 200 psi (0 to 1400 kPa)].

END OF SECTION

SECTION 220523 - GENERAL-DUTY VALVES FOR PLUMBING PIPING

PART 21 - GENERAL

21.1 RELATED DOCUMENTS

- A. Drawings and general provisions of the Contract, including General and Supplementary Conditions and Division 01 Specification Sections, apply to this Section.

21.2 SUMMARY

- A. Section Includes:

1. Bronze ball valves.
2. Iron, single-flange butterfly valves.
3. Bronze swing check valves.
4. Iron swing check valves.
5. Lubricated plug valves.
6. Chainwheels.

- B. Related Sections:

1. Division 22 plumbing piping Sections for specialty valves applicable to those Sections only.
2. Division 22 Section "Identification for Plumbing Piping and Equipment" for valve tags and schedules.

21.3 DEFINITIONS

- A. CWP: Cold working pressure.
- B. EPDM: Ethylene propylene copolymer rubber.
- C. NBR: Acrylonitrile-butadiene, Buna-N, or nitrile rubber.
- D. NRS: Nonrising stem.
- E. OS&Y: Outside screw and yoke.
- F. RS: Rising stem.
- G. SWP: Steam working pressure.

21.4 SUBMITTALS

- A. Product Data: For each type of valve indicated.

21.5 QUALITY ASSURANCE

- A. Source Limitations for Valves: Obtain each type of valve from single source from single manufacturer.
- B. ASME Compliance:
 - 1. ASME B16.10 and ASME B16.34 for ferrous valve dimensions and design criteria.
 - 2. ASME B31.1 for power piping valves.
 - 3. ASME B31.9 for building services piping valves.
- C. NSF Compliance: NSF 61 for valve materials for potable-water service.

21.6 DELIVERY, STORAGE, AND HANDLING

- A. Prepare valves for shipping as follows:
 - 1. Protect internal parts against rust and corrosion.
 - 2. Protect threads, flange faces, grooves, and weld ends.
 - 3. Set angle, gate, and globe valves closed to prevent rattling.
 - 4. Set ball and plug valves open to minimize exposure of functional surfaces.
 - 5. Set butterfly valves closed or slightly open.
 - 6. Block check valves in either closed or open position.
- B. Use the following precautions during storage:
 - 1. Maintain valve end protection.
 - 2. Store valves indoors and maintain at higher than ambient dew point temperature. If outdoor storage is necessary, store valves off the ground in watertight enclosures.
- C. Use sling to handle large valves; rig sling to avoid damage to exposed parts. Do not use handwheels or stems as lifting or rigging points.

PART 22 - PRODUCTS

22.1 GENERAL REQUIREMENTS FOR VALVES

- A. Refer to valve schedule articles for applications of valves.
- B. Valve Pressure and Temperature Ratings: Not less than indicated and as required for system pressures and temperatures.
- C. Valve Sizes: Same as upstream piping unless otherwise indicated.
- D. Valve Actuator Types:
 - 1. Gear Actuator: For quarter-turn valves **NPS 8 (DN 200)** and larger.
 - 2. Handwheel: For valves other than quarter-turn types.
 - 3. Handlever: For quarter-turn valves **NPS 6 (DN 150)** and smaller.
 - 4. Wrench: For plug valves with square heads. Furnish Owner with 1 wrench for every 5 plug valves, for each size square plug-valve head.

5. Chainwheel: Device for attachment to valve handwheel, stem, or other actuator; of size and with chain for mounting height, as indicated in the "Valve Installation" Article.
- E. Valves in Insulated Piping: With **2-inch (50-mm)** stem extensions and the following features:
1. Gate Valves: With rising stem.
 2. Ball Valves: With extended operating handle of non-thermal-conductive material, and protective sleeve that allows operation of valve without breaking the vapor seal or disturbing insulation.
 3. Butterfly Valves: With extended neck.
- F. Valve-End Connections:
1. Flanged: With flanges according to ASME B16.1 for iron valves.
 2. Grooved: With grooves according to AWWA C606.
 3. Solder Joint: With sockets according to ASME B16.18.
 4. Threaded: With threads according to ASME B1.20.1.
- G. Valve Bypass and Drain Connections: MSS SP-45.

22.2 BRONZE BALL VALVES

- A. Two-Piece, Full-Port, Bronze Ball Valves with Silicon Bronze Trim:
1. Manufacturers: Subject to compliance with requirements, provide products by one of the following:
 - a. American Valve, Inc.
 - b. Conbraco Industries, Inc.; Apollo Valves.
 - c. NIBCO INC.
 2. Description:
 - a. Standard: MSS SP-110.
 - b. CWP Rating: **400 psig (2760 kPa)**.
 - c. Body Design: Two piece.
 - d. Body Material: Silicon Performance Bronze Alloy, ASTM-584.
 - e. Ends: Threaded.
 - f. Seats: PTFE or TFE.
 - g. Stem: Silicon Bronze ASTM B371.
 - h. Ball: Silicon Bronze ASTM B283.
 - i. Port: Full.
- B. Two-Piece, Full-Port, Bronze Ball Valves with Stainless-Steel Trim:
1. Manufacturers: Subject to compliance with requirements, provide products by one of the following:
 - a. Conbraco Industries, Inc.; Apollo Valves.
 - b. Crane Co.; Crane Valve Group; Crane Valves.

- c. Hammond Valve.
- d. Lance Valves; a division of Advanced Thermal Systems, Inc.
- e. Milwaukee Valve Company.
- f. NIBCO INC.
- g. Watts Regulator Co.; a division of Watts Water Technologies, Inc.

2. Description:

- a. Standard: MSS SP-110.
- b. SWP Rating: 150 psig (1035 kPa).
- c. CWP Rating: 600 psig (4140 kPa).
- d. Body Design: Two piece.
- e. Body Material: Bronze.
- f. Ends: Threaded.
- g. Seats: PTFE or TFE.
- h. Stem: Stainless steel.
- i. Ball: Stainless steel, vented.
- j. Port: Full.

22.3 IRON, SINGLE-FLANGE BUTTERFLY VALVES

A. 200 CWP, Iron, Single-Flange Butterfly Valves with EPDM Seat and Aluminum-Bronze Disc:

1. Manufacturers: Subject to compliance with requirements, provide products by one of the following:

- a. ABZ Valve and Controls; a division of ABZ Manufacturing, Inc.
- b. Conbraco Industries, Inc.; Apollo Valves.
- c. Cooper Cameron Valves; a division of Cooper Cameron Corporation.
- d. Crane Co.; Crane Valve Group; Jenkins Valves.
- e. Crane Co.; Crane Valve Group; Stockham Division.
- f. DeZurik Water Controls.
- g. Flo Fab Inc.
- h. Hammond Valve.
- i. Kitz Corporation.
- j. Legend Valve.
- k. Milwaukee Valve Company.
- l. NIBCO INC.
- m. Norriseal; a Dover Corporation company.
- n. Red-White Valve Corporation.
- o. Spence Strainers International; a division of CIRCOR International, Inc.
- p. Watts Regulator Co.; a division of Watts Water Technologies, Inc.

2. Description:

- a. Standard: MSS SP-67, Type I.
- b. CWP Rating: 200 psig (1380 kPa).
- c. Body Design: Lug type; suitable for bidirectional dead-end service at rated pressure without use of downstream flange.
- d. Body Material: ASTM A 126, cast iron or ASTM A 536, ductile iron.
- e. Seat: EPDM.

- f. Stem: One- or two-piece stainless steel.
- g. Disc: Aluminum bronze.

B. 200 CWP, Iron, Single-Flange Butterfly Valves with EPDM Seat and Ductile-Iron Disc:

1. Manufacturers: Subject to compliance with requirements, provide products by one of the following:
 - a. ABZ Valve and Controls; a division of ABZ Manufacturing, Inc.
 - b. American Valve, Inc.
 - c. Conbraco Industries, Inc.; Apollo Valves.
 - d. Cooper Cameron Valves; a division of Cooper Cameron Corporation.
 - e. Crane Co.; Crane Valve Group; Center Line.
 - f. Crane Co.; Crane Valve Group; Stockham Division.
 - g. DeZurik Water Controls.
 - h. Flo Fab Inc.
 - i. Hammond Valve.
 - j. Kitz Corporation.
 - k. Legend Valve.
 - l. Milwaukee Valve Company.
 - m. Mueller Steam Specialty; a division of SPX Corporation.
 - n. NIBCO INC.
 - o. Norriseal; a Dover Corporation company.
 - p. Spence Strainers International; a division of CIRCOR International, Inc.
 - q. Sure Flow Equipment Inc.
 - r. Watts Regulator Co.; a division of Watts Water Technologies, Inc.

2. Description:

- a. Standard: MSS SP-67, Type I.
- b. CWP Rating: 200 psig (1380 kPa).
- c. Body Design: Lug type; suitable for bidirectional dead-end service at rated pressure without use of downstream flange.
- d. Body Material: ASTM A 126, cast iron or ASTM A 536, ductile iron.
- e. Seat: EPDM.
- f. Stem: One- or two-piece stainless steel.
- g. Disc: Nickel-plated or -coated ductile iron.

C. 200 CWP, Iron, Single-Flange Butterfly Valves with NBR Seat and Ductile-Iron Disc:

1. Manufacturers: Subject to compliance with requirements, provide products by one of the following:
 - a. ABZ Valve and Controls; a division of ABZ Manufacturing, Inc.
 - b. American Valve, Inc.
 - c. Conbraco Industries, Inc.; Apollo Valves.
 - d. Cooper Cameron Valves; a division of Cooper Cameron Corporation.
 - e. Crane Co.; Crane Valve Group; Center Line.
 - f. Crane Co.; Crane Valve Group; Stockham Division.
 - g. DeZurik Water Controls.
 - h. Flo Fab Inc.
 - i. Hammond Valve.
 - j. Kitz Corporation.
 - k. Legend Valve.

- l. Milwaukee Valve Company.
 - m. Mueller Steam Specialty; a division of SPX Corporation.
 - n. NIBCO INC.
 - o. Norriseal; a Dover Corporation company.
 - p. Spence Strainers International; a division of CIRCOR International, Inc.
 - q. Sure Flow Equipment Inc.
 - r. Watts Regulator Co.; a division of Watts Water Technologies, Inc.
2. Description:
- a. Standard: MSS SP-67, Type I.
 - b. CWP Rating: 200 psig (1380 kPa).
 - c. Body Design: Lug type; suitable for bidirectional dead-end service at rated pressure without use of downstream flange.
 - d. Body Material: ASTM A 126, cast iron or ASTM A 536, ductile iron.
 - e. Seat: NBR.
 - f. Stem: One- or two-piece stainless steel.
 - g. Disc: Nickel-plated or -coated ductile iron.
- D. 200 CWP, Iron, Single-Flange Butterfly Valves with EPDM Seat and Stainless-Steel Disc:
1. Manufacturers: Subject to compliance with requirements, provide products by one of the following:
- a. ABZ Valve and Controls; a division of ABZ Manufacturing, Inc.
 - b. American Valve, Inc.
 - c. Conbraco Industries, Inc.; Apollo Valves.
 - d. Cooper Cameron Valves; a division of Cooper Cameron Corporation.
 - e. Crane Co.; Crane Valve Group; Jenkins Valves.
 - f. Crane Co.; Crane Valve Group; Stockham Division.
 - g. DeZurik Water Controls.
 - h. Flo Fab Inc.
 - i. Hammond Valve.
 - j. Kitz Corporation.
 - k. Legend Valve.
 - l. Milwaukee Valve Company.
 - m. Mueller Steam Specialty; a division of SPX Corporation.
 - n. NIBCO INC.
 - o. Norriseal; a Dover Corporation company.
 - p. Red-White Valve Corporation.
 - q. Spence Strainers International; a division of CIRCOR International, Inc.
 - r. Sure Flow Equipment Inc.
 - s. Watts Regulator Co.; a division of Watts Water Technologies, Inc.
2. Description:
- a. Standard: MSS SP-67, Type I.
 - b. CWP Rating: 200 psig (1380 kPa).
 - c. Body Design: Lug type; suitable for bidirectional dead-end service at rated pressure without use of downstream flange.
 - d. Body Material: ASTM A 126, cast iron or ASTM A 536, ductile iron.
 - e. Seat: EPDM.
 - f. Stem: One- or two-piece stainless steel.
 - g. Disc: Stainless steel.

E. 200 CWP, Iron, Single-Flange Butterfly Valves with NBR Seat and Stainless-Steel Disc:

1. Manufacturers: Subject to compliance with requirements, provide products by one of the following:

- a. ABZ Valves and Controls; A div. of ABZ Manufacturing, Inc.
- b. American Valve, Inc.
- c. Conbraco Industries, Inc.; Apollo Valves.
- d. Cooper Cameron Valves; A div. of Cooper Cameron Corp.
- e. Crane Co.; Crane Valve Group; Jenkins Valves.
- f. Crane Co.; Crane Valve Group; Stockham Div.
- g. DeZurik Water Controls.
- h. Flo Fab Inc.
- i. Hammond Valve.
- j. Kitz Corporation.
- k. Legend Valve.
- l. Milwaukee Valve Company.
- m. Mueller Steam Specialty; a division of SPX Corporation.
- n. NIBCO INC.
- o. Norriseal; a Dover Corporation company.
- p. Red-White Valve Corporation.
- q. Spence Strainers International; a division of CIRCOR International, Inc.
- r. Sure Flow Equipment Inc.
- s. Watts Regulator Co.; a division of Watts Water Technologies, Inc.

2. Description:

- a. Standard: MSS SP-67, Type I.
- b. CWP Rating: 200 psig (1380 kPa).
- c. Body Design: Lug type; suitable for bidirectional dead-end service at rated pressure without use of downstream flange.
- d. Body Material: ASTM A 126, cast iron or ASTM A 536, ductile iron.
- e. Seat: NBR.
- f. Stem: One- or two-piece stainless steel.
- g. Disc: Stainless steel.

22.4 BRONZE SWING CHECK VALVES

A. Class 125, Bronze Swing Check Valves with Bronze Disc:

1. Manufacturers: Subject to compliance with requirements, provide products by one of the following:

- a. American Valve, Inc.
- b. Crane Co.; Crane Valve Group; Crane Valves.
- c. Crane Co.; Crane Valve Group; Jenkins Valves.
- d. Crane Co.; Crane Valve Group; Stockham Division.
- e. Hammond Valve.
- f. Kitz Corporation.
- g. Milwaukee Valve Company.
- h. NIBCO INC.
- i. Powell Valves.

- j. Red-White Valve Corporation.
- k. Watts Regulator Co.; a division of Watts Water Technologies, Inc.
- l. Zy-Tech Global Industries, Inc.

2. Description:

- a. Standard: MSS SP-80, Type 3.
- b. CWP Rating: 200 psig (1380 kPa).
- c. Body Design: Horizontal flow.
- d. Body Material: ASTM B 62, bronze.
- e. Ends: Threaded.
- f. Disc: Bronze.

B. Class 125, Bronze Swing Check Valves with Nonmetallic Disc:

1. Manufacturers: Subject to compliance with requirements, provide products by one of the following:

- a. Crane Co.; Crane Valve Group; Crane Valves.
- b. Crane Co.; Crane Valve Group; Jenkins Valves.
- c. Crane Co.; Crane Valve Group; Stockham Division.
- d. Hammond Valve.
- e. Kitz Corporation.
- f. Milwaukee Valve Company.
- g. NIBCO INC.
- h. Red-White Valve Corporation.
- i. Watts Regulator Co.; a division of Watts Water Technologies, Inc.

2. Description:

- a. Standard: MSS SP-80, Type 4.
- b. CWP Rating: 200 psig (1380 kPa).
- c. Body Design: Horizontal flow.
- d. Body Material: ASTM B 62, bronze.
- e. Ends: Threaded.
- f. Disc: PTFE or TFE.

C. Class 150, Bronze Swing Check Valves with Bronze Disc:

1. Manufacturers: Subject to compliance with requirements, provide products by one of the following:

- a. American Valve, Inc.
- b. Crane Co.; Crane Valve Group; Crane Valves.
- c. Crane Co.; Crane Valve Group; Jenkins Valves.
- d. Crane Co.; Crane Valve Group; Stockham Division.
- e. Kitz Corporation.
- f. Milwaukee Valve Company.
- g. NIBCO INC.
- h. Red-White Valve Corporation.
- i. Zy-Tech Global Industries, Inc.

2. Description:

- a. Standard: MSS SP-80, Type 3.
- b. CWP Rating: 300 psig (2070 kPa).
- c. Body Design: Horizontal flow.
- d. Body Material: ASTM B 62, bronze.
- e. Ends: Threaded.
- f. Disc: Bronze.

D. Class 150, Bronze Swing Check Valves with Nonmetallic Disc:

1. Manufacturers: Subject to compliance with requirements, provide products by one of the following:
 - a. Crane Co.; Crane Valve Group; Crane Valves.
 - b. Crane Co.; Crane Valve Group; Jenkins Valves.
 - c. Hammond Valve.
 - d. Milwaukee Valve Company.
 - e. NIBCO INC.
 - f. Watts Regulator Co.; a division of Watts Water Technologies, Inc.
2. Description:
 - a. Standard: MSS SP-80, Type 4.
 - b. CWP Rating: 300 psig (2070 kPa).
 - c. Body Design: Horizontal flow.
 - d. Body Material: ASTM B 62, bronze.
 - e. Ends: Threaded.
 - f. Disc: PTFE or TFE.

22.5 LUBRICATED PLUG VALVES

A. Class 125, Regular-Gland, Lubricated Plug Valves with Threaded Ends:

1. Manufacturers: Subject to compliance with requirements, provide products by one of the following:
 - a. Nordstrom Valves, Inc.
2. Description:
 - a. Standard: MSS SP-78, Type II.
 - b. CWP Rating: 200 psig (1380 kPa).
 - c. Body Material: ASTM A 48/A 48M or ASTM A 126, cast iron with lubrication-sealing system.
 - d. Pattern: Regular or short.
 - e. Plug: Cast iron or bronze with sealant groove.

B. Class 125, Regular-Gland, Lubricated Plug Valves with Flanged Ends:

1. Manufacturers: Subject to compliance with requirements, provide products by one of the following:
 - a. Nordstrom Valves, Inc.

2. Description:
 - a. Standard: MSS SP-78, Type II.
 - b. CWP Rating: 200 psig (1380 kPa).
 - c. Body Material: ASTM A 48/A 48M or ASTM A 126, cast iron with lubrication-sealing system.
 - d. Pattern: Regular or short
 - e. Plug: Cast iron or bronze with sealant groove.

C. Class 125, Cylindrical, Lubricated Plug Valves with Threaded Ends:

1. Manufacturers: Subject to compliance with requirements, provide products by one of the following:
 - a. Homestead Valve; a division of Olson Technologies, Inc.
 - b. Milliken Valve Company.
 - c. R & M Energy Systems; a unit of Robbins & Myers, Inc.
2. Description:
 - a. Standard: MSS SP-78, Type IV.
 - b. CWP Rating: 200 psig (1380 kPa).
 - c. Body Material: ASTM A 48/A 48M or ASTM A 126, cast iron with lubrication-sealing system.
 - d. Pattern: Regular or short
 - e. Plug: Cast iron or bronze with sealant groove.

D. Class 125, Cylindrical, Lubricated Plug Valves with Flanged Ends:

1. Manufacturers: Subject to compliance with requirements, provide products by one of the following:
 - a. Homestead Valve; a division of Olson Technologies, Inc.
 - b. Milliken Valve Company.
 - c. R & M Energy Systems; a unit of Robbins & Myers, Inc.
2. Description:
 - a. Standard: MSS SP-78, Type IV.
 - b. CWP Rating: 200 psig (1380 kPa).
 - c. Body Material: ASTM A 48/A 48M or ASTM A 126, cast iron with lubrication-sealing system.
 - d. Pattern: Regular or short
 - e. Plug: Cast iron or bronze with sealant groove.

E. Class 250, Regular-Gland, Lubricated Plug Valves with Threaded Ends:

1. Manufacturers: Subject to compliance with requirements, provide products by one of the following:
 - a. Nordstrom Valves, Inc.
2. Description:

- a. Standard: MSS SP-78, Type II.
- b. CWP Rating: 400 psig (2760 kPa).
- c. Body Material: ASTM A 48/A 48M or ASTM A 126, cast iron with lubrication-sealing system.
- d. Pattern: Regular or short
- e. Plug: Cast iron or bronze with sealant groove.

F. Class 250, Regular-Gland, Lubricated Plug Valves with Flanged Ends:

- 1. Manufacturers: Subject to compliance with requirements, provide products by one of the following:
 - a. Nordstrom Valves, Inc.
- 2. Description:
 - a. Standard: MSS SP-78, Type II.
 - b. CWP Rating: 400 psig (2760 kPa).
 - c. Body Material: ASTM A 48/A 48M or ASTM A 126, cast iron with lubrication-sealing system.
 - d. Pattern: Regular or short
 - e. Plug: Cast iron or bronze with sealant groove.

G. Class 250, Cylindrical, Lubricated Plug Valves with Threaded Ends:

- 1. Manufacturers: Subject to compliance with requirements, provide products by one of the following:
 - a. Homestead Valve; a division of Olson Technologies, Inc.
 - b. Milliken Valve Company.
 - c. R & M Energy Systems; a unit of Robbins & Myers, Inc.
- 2. Description:
 - a. Standard: MSS SP-78, Type IV.
 - b. CWP Rating: 400 psig (2760 kPa).
 - c. Body Material: ASTM A 48/A 48M or ASTM A 126, cast iron with lubrication-sealing system.
 - d. Pattern: Regular or short.
 - e. Plug: Cast iron or bronze with sealant groove.

H. Class 250, Cylindrical, Lubricated Plug Valves with Flanged Ends:

- 1. Manufacturers: Subject to compliance with requirements, provide products by one of the following:
 - a. Homestead Valve; a division of Olson Technologies, Inc.
 - b. Milliken Valve Company.
 - c. R & M Energy Systems; a unit of Robbins & Myers, Inc.
- 2. Description:
 - a. Standard: MSS SP-78, Type IV.

- b. CWP Rating: 400 psig (2760 kPa).
- c. Body Material: ASTM A 48/A 48M or ASTM A 126, Grade 40 cast iron with lubrication-sealing system.
- d. Pattern: Regular or short
- e. Plug: Cast iron or bronze with sealant groove.

22.6 CHAINWHEELS

- A. Manufacturers: Subject to compliance with requirements, provide products by one of the following:
 - 1. Babbitt Steam Specialty Co.
 - 2. Roto Hammer Industries.
 - 3. Trumbull Industries.
- B. Description: Valve actuation assembly with sprocket rim, brackets, and chain.
 - 1. Brackets: Type, number, size, and fasteners required to mount actuator on valve.
 - 2. Attachment: For connection to butterfly valve stems.
 - 3. Sprocket Rim with Chain Guides: Ductile iron of type and size required for valve.
 - 4. Chain: Hot-dip, galvanized steel of size required to fit sprocket rim.

PART 23 - EXECUTION

23.1 EXAMINATION

- A. Examine valve interior for cleanliness, freedom from foreign matter, and corrosion. Remove special packing materials, such as blocks, used to prevent disc movement during shipping and handling.
- B. Operate valves in positions from fully open to fully closed. Examine guides and seats made accessible by such operations.
- C. Examine threads on valve and mating pipe for form and cleanliness.
- D. Examine mating flange faces for conditions that might cause leakage. Check bolting for proper size, length, and material. Verify that gasket is of proper size, that its material composition is suitable for service, and that it is free from defects and damage.
- E. Do not attempt to repair defective valves; replace with new valves.

23.2 VALVE INSTALLATION

- A. Install valves with unions or flanges at each piece of equipment arranged to allow service, maintenance, and equipment removal without system shutdown.
- B. Locate valves for easy access and provide separate support where necessary.
- C. Install valves in horizontal piping with stem at or above center of pipe.

- D. Install valves in position to allow full stem movement.
- E. Install chainwheels on operators for butterfly valves **NPS 4 (DN 100)** and larger and more than **96 inches (2400 mm)** above floor. Extend chains to **60 inches (1520 mm)** above finished floor.
- F. Install check valves for proper direction of flow and as follows:
 1. Swing Check Valves: In horizontal position with hinge pin level.

23.3 ADJUSTING

- A. Adjust or replace valve packing after piping systems have been tested and put into service but before final adjusting and balancing. Replace valves if persistent leaking occurs.

23.4 GENERAL REQUIREMENTS FOR VALVE APPLICATIONS

- A. If valve applications are not indicated, use the following:
 1. Shutoff Service: Ball, butterfly valves.
 2. Butterfly Valve Dead-End Service: Single-flange (lug) type.
 3. Balancing Service: Calibrated balancing valve.
 4. Pump-Discharge Check Valves:
 - a. **NPS 2 (DN 50)** and Smaller: Bronze swing check valves with bronze disc.
- B. If valves with specified SWP classes or CWP ratings are not available, the same types of valves with higher SWP classes or CWP ratings may be substituted.
- C. Select valves, except wafer types, with the following end connections:
 1. For Copper Tubing, **NPS 2 (DN 50)** and Smaller: Threaded ends except where solder-joint valve-end option is indicated in valve schedules below.
 2. For Copper Tubing, **NPS 2-1/2 to NPS 4 (DN 65 to DN 100)**: Flanged ends except where threaded valve-end option is indicated in valve schedules below.
 3. For Copper Tubing, **NPS 5 (DN 125)** and Larger: Flanged ends.
 4. For Steel Piping, **NPS 2 (DN 50)** and Smaller: Threaded ends.
 5. For Steel Piping, **NPS 2-1/2 to NPS 4 (DN 65 to DN 100)**: Flanged ends except where threaded valve-end option is indicated in valve schedules below.
 6. For Steel Piping, **NPS 5 (DN 125)** and Larger: Flanged ends.

23.5 DOMESTIC, HOT- AND COLD-WATER VALVE SCHEDULE

- A. Pipe **NPS 2 (DN 50)** and Smaller:
 1. Bronze Valves: May be provided with solder-joint ends instead of threaded ends.
 2. Bronze Angle Valves: Class 125 disc.
 3. Ball Valves: Two piece, full port, bronze with stainless-steel trim.
 4. Bronze Swing Check Valves: Class 125 disc.
- B. Pipe **NPS 2-1/2 (DN 65)** and Larger:

1. Iron Valves, **NPS 2-1/2 to NPS 4 (DN 65 to DN 100)**: May be provided with threaded ends instead of flanged ends.
2. Iron Ball Valves: Class 150.
3. Iron, Single-Flange Butterfly Valves: 200 CWP, EPDM seat, stainless-steel disc.
4. Iron Swing Check Valves: Class 125 seats.

END OF SECTION

SECTION 220529 - HANGERS AND SUPPORTS FOR PLUMBING PIPING AND EQUIPMENT

PART 25 - GENERAL

25.1 RELATED DOCUMENTS

- A. Drawings and general provisions of the Contract, including General and Supplementary Conditions and Division 01 Specification Sections, apply to this Section.

25.2 SUMMARY

- A. Section Includes:

1. Metal pipe hangers and supports.
2. Trapeze pipe hangers.
3. Fiberglass pipe hangers.
4. Metal framing systems.
5. Fiberglass strut systems.
6. Thermal-hanger shield inserts.
7. Fastener systems.
8. Pipe stands.
9. Pipe positioning systems.
10. Equipment supports.

- B. Related Sections:

1. Division 05 Section "Metal Fabrications" for structural-steel shapes and plates for trapeze hangers for pipe and equipment supports.
2. Division 22 Section "Vibration and Seismic Controls for Plumbing Piping and Equipment" for vibration isolation devices.

25.3 DEFINITIONS

- A. MSS: Manufacturers Standardization Society of The Valve and Fittings Industry Inc.

25.4 PERFORMANCE REQUIREMENTS

- A. Delegated Design: Design trapeze pipe hangers and equipment supports, including comprehensive engineering analysis by a qualified professional engineer, using performance requirements and design criteria indicated.
- B. Structural Performance: Hangers and supports for plumbing piping and equipment shall withstand the effects of gravity loads and stresses within limits and under conditions indicated according to ASCE/SEI 7.

1. Design supports for multiple pipes, including pipe stands, capable of supporting combined weight of supported systems, system contents, and test water.
2. Design equipment supports capable of supporting combined operating weight of supported equipment and connected systems and components.
3. Design seismic-restraint hangers and supports for piping and equipment and obtain approval from authorities having jurisdiction.

25.5 SUBMITTALS

- A. Product Data: For each type of product indicated.
- B. Shop Drawings: Signed and sealed by a qualified professional engineer. Show fabrication and installation details and include calculations for the following; include Product Data for components:
 1. Trapeze pipe hangers.
 2. Metal framing systems.
 3. Fiberglass strut systems.
 4. Pipe stands.
 5. Equipment supports.
- C. Delegated-Design Submittal: For trapeze hangers indicated to comply with performance requirements and design criteria, including analysis data signed and sealed by the qualified professional engineer responsible for their preparation.
 1. Detail fabrication and assembly of trapeze hangers.
 2. Design Calculations: Calculate requirements for designing trapeze hangers.
- D. Welding certificates.

25.6 QUALITY ASSURANCE

- A. Structural Steel Welding Qualifications: Qualify procedures and personnel according to AWS D1.1/D1.1M, "Structural Welding Code - Steel."
- B. Pipe Welding Qualifications: Qualify procedures and operators according to ASME Boiler and Pressure Vessel Code.

PART 26 - PRODUCTS

26.1 METAL PIPE HANGERS AND SUPPORTS

- A. Carbon-Steel Pipe Hangers and Supports:
 1. Description: MSS SP-58, Types 1 through 58, factory-fabricated components.
 2. Galvanized Metallic Coatings: Pregalvanized or hot dipped.
 3. Nonmetallic Coatings: Plastic coating, jacket, or liner.
 4. Padded Hangers: Hanger with fiberglass or other pipe insulation pad or cushion to support bearing surface of piping.
 5. Hanger Rods: Continuous-thread rod, nuts, and washer made of carbon steel

B. Stainless-Steel Pipe Hangers and Supports:

1. Description: MSS SP-58, Types 1 through 58, factory-fabricated components.
2. Padded Hangers: Hanger with fiberglass or other pipe insulation pad or cushion to support bearing surface of piping.
3. Hanger Rods: Continuous-thread rod, nuts, and washer made of stainless steel.

C. Copper Pipe Hangers:

1. Description: MSS SP-58, Types 1 through 58, copper-coated-steel, factory-fabricated components.
2. Hanger Rods: Continuous-thread rod, nuts, and washer made of copper-coated steel

26.2 TRAPEZE PIPE HANGERS

- A. Description: MSS SP-69, Type 59, shop- or field-fabricated pipe-support assembly made from structural carbon-steel shapes with MSS SP-58 carbon-steel hanger rods, nuts, saddles, and U-bolts.

26.3 METAL FRAMING SYSTEMS

A. MFMA Manufacturer Metal Framing Systems:

1. Manufacturers: Subject to compliance with requirements, provide products by one of the following:
 - a. Allied Tube & Conduit.
 - b. Cooper B-Line, Inc.
 - c. Flex-Strut Inc.
 - d. GS Metals Corp.
 - e. Thomas & Betts Corporation.
 - f. Unistrut Corporation; Tyco International, Ltd.
 - g. Wesanco, Inc.
2. Description: Shop- or field-fabricated pipe-support assembly for supporting multiple parallel pipes.
3. Standard: MFMA-4.
4. Channels: Continuous slotted steel channel with inturred lips.
5. Channel Nuts: Formed or stamped steel nuts or other devices designed to fit into channel slot and, when tightened, prevent slipping along channel.
6. Hanger Rods: Continuous-thread rod, nuts, and washer made of carbon steel.
7. Metallic Coating: Electroplated zinc
8. Paint Coating: Vinyl, Epoxy, Acrylic.
9. Plastic Coating: PVC

B. Non-MFMA Manufacturer Metal Framing Systems:

1. Manufacturers: Subject to compliance with requirements, provide products by one of the following:
 - a. Anvil International; a subsidiary of Mueller Water Products Inc.
 - b. Empire Industries, Inc.

- c. ERICO International Corporation.
 - d. Haydon Corporation; H-Strut Division.
 - e. NIBCO INC.
 - f. PHD Manufacturing, Inc.
 - g. PHS Industries, Inc.
2. Description: Shop- or field-fabricated pipe-support assembly made of steel channels, accessories, fittings, and other components for supporting multiple parallel pipes.
 3. Standard: Comply with MFMA-4.
 4. Channels: Continuous slotted steel channel with inturred lips.
 5. Channel Nuts: Formed or stamped steel nuts or other devices designed to fit into channel slot and, when tightened, prevent slipping along channel.
 6. Hanger Rods: Continuous-thread rod, nuts, and washer made of carbon steel.
 7. Coating: Zinc.

26.4 THERMAL-HANGER SHIELD INSERTS

- A. Manufacturers: Subject to compliance with requirements, provide products by one of the following:
 1. Carpenter & Paterson, Inc.
 2. Clement Support Services.
 3. ERICO International Corporation.
 4. National Pipe Hanger Corporation.
 5. PHS Industries, Inc.
 6. Pipe Shields, Inc.; a subsidiary of Piping Technology & Products, Inc.
 7. Piping Technology & Products, Inc.
 8. Rilco Manufacturing Co., Inc.
 9. Value Engineered Products, Inc.
- B. Insulation-Insert Material for Cold Piping: ASTM C 552, Type II cellular glass with 100-psig (688-kPa) or ASTM C 591, Type VI, Grade 1 polyisocyanurate with 125-psig (862-kPa) minimum compressive strength and vapor barrier.
- C. Insulation-Insert Material for Hot Piping: Water-repellent treated, ASTM C 533, Type I calcium silicate with 100-psig (688-kPa) [ASTM C 552, Type II cellular glass with 100-psig (688-kPa) or ASTM C 591, Type VI, Grade 1 polyisocyanurate with 125-psig (862-kPa)] minimum compressive strength.
- D. For Trapeze or Clamped Systems: Insert and shield shall cover entire circumference of pipe.
- E. For Clevis or Band Hangers: Insert and shield shall cover lower 180 degrees of pipe.
- F. Insert Length: Extend 2 inches (50 mm) beyond sheet metal shield for piping operating below ambient air temperature.

26.5 FASTENER SYSTEMS

- A. Powder-Actuated Fasteners: Threaded-steel stud, for use in hardened portland cement concrete with pull-out, tension, and shear capacities appropriate for supported loads and building materials where used.

- B. Mechanical-Expansion Anchors: Insert-wedge-type, zinc-coated steel anchors, for use in hardened portland cement concrete; with pull-out, tension, and shear capacities appropriate for supported loads and building materials where used.

26.6 PIPE STANDS

- A. General Requirements for Pipe Stands: Shop- or field-fabricated assemblies made of manufactured corrosion-resistant components to support roof-mounted piping.
- B. Compact Pipe Stand: One-piece plastic unit with integral-rod roller, pipe clamps, or V-shaped cradle to support pipe, for roof installation without membrane penetration.
- C. Low-Type, Single-Pipe Stand: One-piece plastic base unit with plastic roller, for roof installation without membrane penetration.
- D. High-Type, Single-Pipe Stand:
 - 1. Description: Assembly of base, vertical and horizontal members, and pipe support, for roof installation without membrane penetration.
 - 2. Base: Plastic.
 - 3. Vertical Members: Two or more cadmium-plated-steel or stainless-steel, continuous-thread rods.
 - 4. Horizontal Member: Cadmium-plated-steel or stainless-steel rod with plastic or stainless-steel, roller-type pipe support.
- E. High-Type, Multiple-Pipe Stand:
 - 1. Description: Assembly of bases, vertical and horizontal members, and pipe supports, for roof installation without membrane penetration.
 - 2. Bases: One or more; plastic.
 - 3. Vertical Members: Two or more protective-coated-steel channels.
 - 4. Horizontal Member: Protective-coated-steel channel.
 - 5. Pipe Supports: Galvanized-steel, clevis-type pipe hangers.
- F. Curb-Mounting-Type Pipe Stands: Shop- or field-fabricated pipe supports made from structural-steel shapes, continuous-thread rods, and rollers, for mounting on permanent stationary roof curb.

26.7 PIPE POSITIONING SYSTEMS

- A. Description: IAPMO PS 42, positioning system of metal brackets, clips, and straps for positioning piping in pipe spaces; for plumbing fixtures in commercial applications.

26.8 EQUIPMENT SUPPORTS

- A. Description: Welded, shop- or field-fabricated equipment support made from structural carbon-steel shapes.

26.9 MISCELLANEOUS MATERIALS

- A. Structural Steel: ASTM A 36/A 36M, carbon-steel plates, shapes, and bars; black and galvanized.
- B. Grout: ASTM C 1107, factory-mixed and -packaged, dry, hydraulic-cement, nonshrink and nonmetallic grout; suitable for interior and exterior applications.
 - 1. Properties: Nonstaining, noncorrosive, and nongaseous.
 - 2. Design Mix: 5000-psi (34.5-MPa), 28-day compressive strength.

PART 27 - EXECUTION

27.1 HANGER AND SUPPORT INSTALLATION

- A. Metal Pipe-Hanger Installation: Comply with MSS SP-69 and MSS SP-89. Install hangers, supports, clamps, and attachments as required to properly support piping from the building structure.
- B. Metal Trapeze Pipe-Hanger Installation: Comply with MSS SP-69 and MSS SP-89. Arrange for grouping of parallel runs of horizontal piping, and support together on field-fabricated trapeze pipe hangers.
 - 1. Pipes of Various Sizes: Support together and space trapezes for smallest pipe size or install intermediate supports for smaller diameter pipes as specified for individual pipe hangers.
 - 2. Field fabricate from ASTM A 36/A 36M, carbon-steel shapes selected for loads being supported. Weld steel according to AWS D1.1/D1.1M.
- C. Fiberglass Pipe-Hanger Installation: Comply with applicable portions of MSS SP-69 and MSS SP-89. Install hangers and attachments as required to properly support piping from building structure.
- D. Metal Framing System Installation: Arrange for grouping of parallel runs of piping, and support together on field-assembled metal framing systems.
- E. Fiberglass Strut System Installation: Arrange for grouping of parallel runs of piping, and support together on field-assembled fiberglass struts.
- F. Thermal-Hanger Shield Installation: Install in pipe hanger or shield for insulated piping.
- G. Fastener System Installation:
 - 1. Install powder-actuated fasteners for use in lightweight concrete or concrete slabs less than 4 inches (100 mm) thick in concrete after concrete is placed and completely cured. Use operators that are licensed by powder-actuated tool manufacturer. Install fasteners according to powder-actuated tool manufacturer's operating manual.
 - 2. Install mechanical-expansion anchors in concrete after concrete is placed and completely cured. Install fasteners according to manufacturer's written instructions.
- H. Pipe Stand Installation:

1. Pipe Stand Types except Curb-Mounted Type: Assemble components and mount on smooth roof surface. Do not penetrate roof membrane.

- I. Pipe Positioning-System Installation: Install support devices to make rigid supply and waste piping connections to each plumbing fixture. See Division 22 plumbing fixture Sections for requirements for pipe positioning systems for plumbing fixtures.
- J. Install hangers and supports complete with necessary attachments, inserts, bolts, rods, nuts, washers, and other accessories.
- K. Equipment Support Installation: Fabricate from welded-structural-steel shapes.
- L. Install hangers and supports to allow controlled thermal and seismic movement of piping systems, to permit freedom of movement between pipe anchors, and to facilitate action of expansion joints, expansion loops, expansion bends, and similar units.
- M. Install lateral bracing with pipe hangers and supports to prevent swaying.
- N. Install building attachments within concrete slabs or attach to structural steel. Install additional attachments at concentrated loads, including valves, flanges, and strainers, **NPS 2-1/2 (DN 65)** and larger and at changes in direction of piping. Install concrete inserts before concrete is placed; fasten inserts to forms and install reinforcing bars through openings at top of inserts.
- O. Load Distribution: Install hangers and supports so that piping live and dead loads and stresses from movement will not be transmitted to connected equipment.
- P. Pipe Slopes: Install hangers and supports to provide indicated pipe slopes and to not exceed maximum pipe deflections allowed by ASME B31.9 for building services piping.
- Q. Insulated Piping:
 1. Attach clamps and spacers to piping.
 - a. Piping Operating above Ambient Air Temperature: Clamp may project through insulation.
 - b. Piping Operating below Ambient Air Temperature: Use thermal-hanger shield insert with clamp sized to match OD of insert.
 - c. Do not exceed pipe stress limits allowed by ASME B31.9 for building services piping.
 2. Install MSS SP-58, Type 39, protection saddles if insulation without vapor barrier is indicated. Fill interior voids with insulation that matches adjoining insulation.
 - a. Option: Thermal-hanger shield inserts may be used. Include steel weight-distribution plate for pipe **NPS 4 (DN 100)** and larger if pipe is installed on rollers.
 3. Install MSS SP-58, Type 40, protective shields on cold piping with vapor barrier. Shields shall span an arc of 180 degrees.

- a. Option: Thermal-hanger shield inserts may be used. Include steel weight-distribution plate for pipe **NPS 4 (DN 100)** and larger if pipe is installed on rollers.
4. Shield Dimensions for Pipe: Not less than the following:
- a. **NPS 1/4 to NPS 3-1/2 (DN 8 to DN 90): 12 inches (305 mm) long and 0.048 inch (1.22 mm) thick.**
 - b. **NPS 4 (DN 100): 12 inches (305 mm) long and 0.06 inch (1.52 mm) thick.**
 - c. **NPS 5 and NPS 6 (DN 125 and DN 150): 18 inches (457 mm) long and 0.06 inch (1.52 mm) thick.**
 - d. **NPS 8 to NPS 14 (DN 200 to DN 350): 24 inches (610 mm) long and 0.075 inch (1.91 mm) thick.**
 - e. **NPS 16 to NPS 24 (DN 400 to DN 600): 24 inches (610 mm) long and 0.105 inch (2.67 mm) thick.**
5. Pipes **NPS 8 (DN 200)** and Larger: Include wood or reinforced calcium-silicate-insulation inserts of length at least as long as protective shield.
6. Thermal-Hanger Shields: Install with insulation same thickness as piping insulation.

27.2 EQUIPMENT SUPPORTS

- A. Fabricate structural-steel stands to suspend equipment from structure overhead or to support equipment above floor.
- B. Grouting: Place grout under supports for equipment and make bearing surface smooth.
- C. Provide lateral bracing, to prevent swaying, for equipment supports.

27.3 METAL FABRICATIONS

- A. Cut, drill, and fit miscellaneous metal fabrications for trapeze pipe hangers and equipment supports.
- B. Fit exposed connections together to form hairline joints. Field weld connections that cannot be shop welded because of shipping size limitations.
- C. Field Welding: Comply with AWS D1.1/D1.1M procedures for shielded, metal arc welding; appearance and quality of welds; and methods used in correcting welding work; and with the following:
 - 1. Use materials and methods that minimize distortion and develop strength and corrosion resistance of base metals.
 - 2. Obtain fusion without undercut or overlap.
 - 3. Remove welding flux immediately.
 - 4. Finish welds at exposed connections so no roughness shows after finishing and so contours of welded surfaces match adjacent contours.

27.4 ADJUSTING

- A. Hanger Adjustments: Adjust hangers to distribute loads equally on attachments and to achieve indicated slope of pipe.
- B. Trim excess length of continuous-thread hanger and support rods to 1-1/2 inches (40 mm).

27.5 PAINTING

- A. Touchup: Clean field welds and abraded areas of shop paint. Paint exposed areas immediately after erecting hangers and supports. Use same materials as used for shop painting. Comply with SSPC-PA 1 requirements for touching up field-painted surfaces.
 - 1. Apply paint by brush or spray to provide a minimum dry film thickness of 2.0 mils (0.05 mm).
- B. Touchup: Cleaning and touchup painting of field welds, bolted connections, and abraded areas of shop paint on miscellaneous metal are specified in Division 09 painting Sections.
- C. Galvanized Surfaces: Clean welds, bolted connections, and abraded areas and apply galvanizing-repair paint to comply with ASTM A 780.

27.6 HANGER AND SUPPORT SCHEDULE

- A. Specific hanger and support requirements are in Sections specifying piping systems and equipment.
- B. Comply with MSS SP-69 for pipe-hanger selections and applications that are not specified in piping system Sections.
- C. Use hangers and supports with galvanized metallic coatings for piping and equipment that will not have field-applied finish.
- D. Use nonmetallic coatings on attachments for electrolytic protection where attachments are in direct contact with copper tubing.
- E. Use carbon-steel pipe hangers and supports, metal trapeze pipe hangers and metal framing systems and attachments for general service applications.
- F. Use stainless-steel pipe hangers and stainless-steel or corrosion-resistant attachments for hostile environment applications.
- G. Use copper-plated pipe hangers and copper or stainless-steel attachments for copper piping and tubing.
- H. Use padded hangers for piping that is subject to scratching.
- I. Use thermal-hanger shield inserts for insulated piping and tubing.
- J. Horizontal-Piping Hangers and Supports: Unless otherwise indicated and except as specified in piping system Sections, install the following types:

1. Adjustable, Steel Clevis Hangers (MSS Type 1): For suspension of noninsulated or insulated, stationary pipes **NPS 1/2 to NPS 30 (DN 15 to DN 750)**.
2. Yoke-Type Pipe Clamps (MSS Type 2): For suspension of up to **1050 deg F (566 deg C)**, pipes **NPS 4 to NPS 24 (DN 100 to DN 600)**, requiring up to **4 inches (100 mm)** of insulation.
3. Carbon- or Alloy-Steel, Double-Bolt Pipe Clamps (MSS Type 3): For suspension of pipes **NPS 3/4 to NPS 36 (DN 20 to DN 900)**, requiring clamp flexibility and up to **4 inches (100 mm)** of insulation.
4. Steel Pipe Clamps (MSS Type 4): For suspension of cold and hot pipes **NPS 1/2 to NPS 24 (DN 15 to DN 600)** if little or no insulation is required.
5. Pipe Hangers (MSS Type 5): For suspension of pipes **NPS 1/2 to NPS 4 (DN 15 to DN 100)**, to allow off-center closure for hanger installation before pipe erection.
6. Adjustable, Swivel Split- or Solid-Ring Hangers (MSS Type 6): For suspension of noninsulated, stationary pipes **NPS 3/4 to NPS 8 (DN 20 to DN 200)**.
7. Adjustable, Steel Band Hangers (MSS Type 7): For suspension of noninsulated, stationary pipes **NPS 1/2 to NPS 8 (DN 15 to DN 200)**.
8. Adjustable Band Hangers (MSS Type 9): For suspension of noninsulated, stationary pipes **NPS 1/2 to NPS 8 (DN 15 to DN 200)**.
9. Adjustable, Swivel-Ring Band Hangers (MSS Type 10): For suspension of noninsulated, stationary pipes **NPS 1/2 to NPS 8 (DN 15 to DN 200)**.
10. Split Pipe Ring with or without Turnbuckle Hangers (MSS Type 11): For suspension of noninsulated, stationary pipes **NPS 3/8 to NPS 8 (DN 10 to DN 200)**.
11. Extension Hinged or Two-Bolt Split Pipe Clamps (MSS Type 12): For suspension of noninsulated, stationary pipes **NPS 3/8 to NPS 3 (DN 10 to DN 80)**.
12. U-Bolts (MSS Type 24): For support of heavy pipes **NPS 1/2 to NPS 30 (DN 15 to DN 750)**.
13. Clips (MSS Type 26): For support of insulated pipes not subject to expansion or contraction.
14. Pipe Saddle Supports (MSS Type 36): For support of pipes **NPS 4 to NPS 36 (DN 100 to DN 900)**, with steel-pipe base stanchion support and cast-iron floor flange or carbon-steel plate.
15. Pipe Stanchion Saddles (MSS Type 37): For support of pipes **NPS 4 to NPS 36 (DN 100 to DN 900)**, with steel-pipe base stanchion support and cast-iron floor flange or carbon-steel plate, and with U-bolt to retain pipe.
16. Adjustable Pipe Saddle Supports (MSS Type 38): For stanchion-type support for pipes **NPS 2-1/2 to NPS 36 (DN 65 to DN 900)** if vertical adjustment is required, with steel-pipe base stanchion support and cast-iron floor flange.
17. Single-Pipe Rolls (MSS Type 41): For suspension of pipes **NPS 1 to NPS 30 (DN 25 to DN 750)**, from two rods if longitudinal movement caused by expansion and contraction might occur.
18. Adjustable Roller Hangers (MSS Type 43): For suspension of pipes **NPS 2-1/2 to NPS 24 (DN 65 to DN 600)**, from single rod if horizontal movement caused by expansion and contraction might occur.
19. Complete Pipe Rolls (MSS Type 44): For support of pipes **NPS 2 to NPS 42 (DN 50 to DN 1050)** if longitudinal movement caused by expansion and contraction might occur but vertical adjustment is not necessary.
20. Pipe Roll and Plate Units (MSS Type 45): For support of pipes **NPS 2 to NPS 24 (DN 50 to DN 600)** if small horizontal movement caused by expansion and contraction might occur and vertical adjustment is not necessary.
21. Adjustable Pipe Roll and Base Units (MSS Type 46): For support of pipes **NPS 2 to NPS 30 (DN 50 to DN 750)** if vertical and lateral adjustment during installation might be required in addition to expansion and contraction.

- K. Vertical-Piping Clamps: Unless otherwise indicated and except as specified in piping system Sections, install the following types:
1. Extension Pipe or Riser Clamps (MSS Type 8): For support of pipe risers **NPS 3/4 to NPS 24 (DN 24 to DN 600)**.
 2. Carbon- or Alloy-Steel Riser Clamps (MSS Type 42): For support of pipe risers **NPS 3/4 to NPS 24 (DN 20 to DN 600)** if longer ends are required for riser clamps.
- L. Hanger-Rod Attachments: Unless otherwise indicated and except as specified in piping system Sections, install the following types:
1. Steel Turnbuckles (MSS Type 13): For adjustment up to **6 inches (150 mm)** for heavy loads.
 2. Steel Clevises (MSS Type 14): For **120 to 450 deg F (49 to 232 deg C)** piping installations.
 3. Swivel Turnbuckles (MSS Type 15): For use with MSS Type 11, split pipe rings.
 4. Malleable-Iron Sockets (MSS Type 16): For attaching hanger rods to various types of building attachments.
 5. Steel Weldless Eye Nuts (MSS Type 17): For **120 to 450 deg F (49 to 232 deg C)** piping installations.
- M. Building Attachments: Unless otherwise indicated and except as specified in piping system Sections, install the following types:
1. Steel or Malleable Concrete Inserts (MSS Type 18): For upper attachment to suspend pipe hangers from concrete ceiling.
 2. Top-Beam C-Clamps (MSS Type 19): For use under roof installations with bar-joint construction, to attach to top flange of structural shape.
 3. Side-Beam or Channel Clamps (MSS Type 20): For attaching to bottom flange of beams, channels, or angles.
 4. Center-Beam Clamps (MSS Type 21): For attaching to center of bottom flange of beams.
 5. Welded Beam Attachments (MSS Type 22): For attaching to bottom of beams if loads are considerable and rod sizes are large.
 6. C-Clamps (MSS Type 23): For structural shapes.
 7. Top-Beam Clamps (MSS Type 25): For top of beams if hanger rod is required tangent to flange edge.
 8. Side-Beam Clamps (MSS Type 27): For bottom of steel I-beams.
 9. Steel-Beam Clamps with Eye Nuts (MSS Type 28): For attaching to bottom of steel I-beams for heavy loads.
 10. Linked-Steel Clamps with Eye Nuts (MSS Type 29): For attaching to bottom of steel I-beams for heavy loads, with link extensions.
 11. Malleable-Beam Clamps with Extension Pieces (MSS Type 30): For attaching to structural steel.
 12. Welded-Steel Brackets: For support of pipes from below or for suspending from above by using clip and rod. Use one of the following for indicated loads:
 - a. Light (MSS Type 31): **750 lb (340 kg)**.
 - b. Medium (MSS Type 32): **1500 lb (680 kg)**.
 - c. Heavy (MSS Type 33): **3000 lb (1360 kg)**.
 13. Side-Beam Brackets (MSS Type 34): For sides of steel or wooden beams.

14. Plate Lugs (MSS Type 57): For attaching to steel beams if flexibility at beam is required.
 15. Horizontal Travelers (MSS Type 58): For supporting piping systems subject to linear horizontal movement where headroom is limited.
- N. Saddles and Shields: Unless otherwise indicated and except as specified in piping system Sections, install the following types:
1. Steel-Pipe-Covering Protection Saddles (MSS Type 39): To fill interior voids with insulation that matches adjoining insulation.
 2. Protection Shields (MSS Type 40): Of length recommended in writing by manufacturer to prevent crushing insulation.
 3. Thermal-Hanger Shield Inserts: For supporting insulated pipe.
- O. Spring Hangers and Supports: Unless otherwise indicated and except as specified in piping system Sections, install the following types:
1. Restraint-Control Devices (MSS Type 47): Where indicated to control piping movement.
 2. Spring Cushions (MSS Type 48): For light loads if vertical movement does not exceed **1-1/4 inches (32 mm)**.
 3. Spring-Cushion Roll Hangers (MSS Type 49): For equipping Type 41, roll hanger with springs.
 4. Spring Sway Braces (MSS Type 50): To retard sway, shock, vibration, or thermal expansion in piping systems.
 5. Variable-Spring Hangers (MSS Type 51): Preset to indicated load and limit variability factor to 25 percent to allow expansion and contraction of piping system from hanger.
 6. Variable-Spring Base Supports (MSS Type 52): Preset to indicated load and limit variability factor to 25 percent to allow expansion and contraction of piping system from base support.
 7. Variable-Spring Trapeze Hangers (MSS Type 53): Preset to indicated load and limit variability factor to 25 percent to allow expansion and contraction of piping system from trapeze support.
 8. Constant Supports: For critical piping stress and if necessary to avoid transfer of stress from one support to another support, critical terminal, or connected equipment. Include auxiliary stops for erection, hydrostatic test, and load-adjustment capability. These supports include the following types:
 - a. Horizontal (MSS Type 54): Mounted horizontally.
 - b. Vertical (MSS Type 55): Mounted vertically.
 - c. Trapeze (MSS Type 56): Two vertical-type supports and one trapeze member.
- P. Comply with MSS SP-69 for trapeze pipe-hanger selections and applications that are not specified in piping system Sections.
- Q. Comply with MFMA-103 for metal framing system selections and applications that are not specified in piping system Sections.
- R. Use powder-actuated fasteners or mechanical-expansion anchors instead of building attachments where required in concrete construction.
- S. Use pipe positioning systems in pipe spaces behind plumbing fixtures to support supply and waste piping for plumbing fixtures.

END OF SECTION

SECTION 220548 - VIBRATION AND SEISMIC CONTROLS FOR PLUMBING PIPING AND EQUIPMENT

PART 29 - GENERAL

29.1 RELATED DOCUMENTS

- A. Drawings and general provisions of the Contract, including General and Supplementary Conditions and Division 01 Specification Sections, apply to this Section.

29.2 SUMMARY

- A. This Section includes the following:
 - 1. Pipe riser resilient supports.
 - 2. Resilient pipe guides.
 - 3. Seismic snubbers.
 - 4. Restraining braces and cables.

29.3 DEFINITIONS

- A. IBC: International Building Code.
- B. ICC-ES: ICC-Evaluation Service.
- C. OSHPD: Office of Statewide Health Planning and Development for the State of California.

29.4 PERFORMANCE REQUIREMENTS

- A. Seismic-Restraint Loading:
 - 1. Site Class as Defined in the IBC: D.
 - 2. Assigned Seismic Use Group or Building Category as Defined in the IBC: II.
 - a. Component Importance Factor: 1.0.
 - b. Component Response Modification Factor: 6.5.
 - c. Component Amplification Factor: 4.
 - 3. Design Spectral Response Acceleration at Short Periods (0.2 Second): 1.931%.
 - 4. Design Spectral Response Acceleration at 1-Second Period: 1.026%.

29.5 SUBMITTALS

- A. Product Data: For the following:
 - 1. Include rated load, rated deflection, and overload capacity for each vibration isolation device.

2. Illustrate and indicate style, material, strength, fastening provision, and finish for each type and size of seismic-restraint component used.
 - a. Tabulate types and sizes of seismic restraints, complete with report numbers and rated strength in tension and shear as evaluated by an agency acceptable to authorities having jurisdiction.
 - b. Annotate to indicate application of each product submitted and compliance with requirements.
 3. Interlocking Snubbers: Include ratings for horizontal, vertical, and combined loads.
- B. Delegated-Design Submittal: For vibration isolation and seismic-restraint details indicated to comply with performance requirements and design criteria, including analysis data signed and sealed by the qualified professional engineer responsible for their preparation.
1. Design Calculations: Calculate static and dynamic loading due to equipment weight and operation, seismic forces required to select vibration isolators, seismic restraints, and for designing vibration isolation bases.
 2. Riser Supports: Include riser diagrams and calculations showing anticipated expansion and contraction at each support point, initial and final loads on building structure, spring deflection changes, and seismic loads. Include certification that riser system has been examined for excessive stress and that none will exist.
 3. Vibration Isolation Base Details: Detail overall dimensions, including anchorages and attachments to structure and to supported equipment. Include auxiliary motor slides and rails, base weights, equipment static loads, power transmission, component misalignment, and cantilever loads.
 4. Seismic-Restraint Details:
 - a. Design Analysis: To support selection and arrangement of seismic restraints. Include calculations of combined tensile and shear loads.
 - b. Details: Indicate fabrication and arrangement. Detail attachments of restraints to the restrained items and to the structure. Show attachment locations, methods, and spacings. Identify components, list their strengths, and indicate directions and values of forces transmitted to the structure during seismic events. Indicate association with vibration isolation devices.
 - c. Preapproval and Evaluation Documentation: By an agency acceptable to authorities having jurisdiction, showing maximum ratings of restraint items and the basis for approval (tests or calculations).
- C. Coordination Drawings: Show coordination of seismic bracing for plumbing piping and equipment with other systems and equipment in the vicinity, including other supports and seismic restraints.
- D. Welding certificates.
- E. Qualification Data: For testing agency.
- F. Field quality-control test reports.
- G. Operation and Maintenance Data: For air-mounting systems to include in operation and maintenance manuals.

29.6 QUALITY ASSURANCE

- A. Testing Agency Qualifications: An independent agency, with the experience and capability to conduct the testing indicated, that is a nationally recognized testing laboratory (NRTL) as defined by OSHA in 29 CFR 1910.7, and that is acceptable to authorities having jurisdiction.
- B. Comply with seismic-restraint requirements in the IBC unless requirements in this Section are more stringent.
- C. Welding: Qualify procedures and personnel according to AWS D1.1/D1.1M, "Structural Welding Code - Steel."
- D. Seismic-restraint devices shall have horizontal and vertical load testing and analysis and shall bear anchorage preapproval OPA number from OSHPD, preapproved by ICC-ES, or preapproved by another agency acceptable to authorities having jurisdiction, showing maximum seismic-restraint ratings. Ratings based on independent testing are preferred to ratings based on calculations. If preapproved ratings are not available, submittals based on independent testing are preferred. Calculations (including combining shear and tensile loads) to support seismic-restraint designs must be signed and sealed by a qualified professional engineer.

PART 30 - PRODUCTS

30.1 SEISMIC-RESTRAINT DEVICES

- A. Manufacturers: Subject to compliance with requirements, provide products by one of the following:
 - 1. Amber/Booth Company, Inc.
 - 2. California Dynamics Corporation.
 - 3. Cooper B-Line, Inc.; a division of Cooper Industries.
 - 4. Hilti, Inc.
 - 5. Kinetics Noise Control.
 - 6. Loos & Co.; Cableware Division.
 - 7. Mason Industries.
 - 8. TOLCO Incorporated; a brand of NIBCO INC.
 - 9. Unistrut; Tyco International, Ltd.
- B. General Requirements for Restraint Components: Rated strengths, features, and applications shall be as defined in reports by an evaluation service member of ICC-ES.
 - 1. Structural Safety Factor: Allowable strength in tension, shear, and pullout force of components shall be at least four times the maximum seismic forces to which they will be subjected.
- C. Snubbers: Factory fabricated using welded structural-steel shapes and plates, anchor bolts, and replaceable resilient isolation washers and bushings.
 - 1. Anchor bolts for attaching to concrete shall be seismic-rated, drill-in, and stud-wedge or female-wedge type.
 - 2. Resilient Isolation Washers and Bushings: Oil- and water-resistant neoprene.

3. Maximum 1/4-inch air gap, and minimum 1/4-inch-thick resilient cushion.
- D. Channel Support System: MFMA-3, shop- or field-fabricated support assembly made of slotted steel channels with accessories for attachment to braced component at one end and to building structure at the other end and other matching components and with corrosion-resistant coating; and rated in tension, compression, and torsion forces.
- E. Restraint Cables: ASTM A 603 galvanized-steel cables with end connections made of steel assemblies with thimbles, brackets, swivel, and bolts designed for restraining cable service; and with a minimum of two clamping bolts for cable engagement.
- F. Hanger Rod Stiffener: Steel tube or steel slotted-support-system sleeve with internally bolted connections to hanger rod.
- G. Bushings for Floor-Mounted Equipment Anchor Bolts: Neoprene bushings designed for rigid equipment mountings, and matched to type and size of anchor bolts and studs.
- H. Bushing Assemblies for Wall-Mounted Equipment Anchorage: Assemblies of neoprene elements and steel sleeves designed for rigid equipment mountings, and matched to type and size of attachment devices used.
- I. Resilient Isolation Washers and Bushings: One-piece, molded, oil- and water-resistant neoprene, with a flat washer face.
- J. Mechanical Anchor Bolts: Drilled-in and stud-wedge or female-wedge type in zinc-coated steel for interior applications and stainless steel for exterior applications. Select anchor bolts with strength required for anchor and as tested according to ASTM E 488. Minimum length of eight times diameter.
- K. Adhesive Anchor Bolts: Drilled-in and capsule anchor system containing polyvinyl or urethane methacrylate-based resin and accelerator, or injected polymer or hybrid mortar adhesive. Provide anchor bolts and hardware with zinc-coated steel for interior applications and stainless steel for exterior applications. Select anchor bolts with strength required for anchor and as tested according to ASTM E 488.

30.2 FACTORY FINISHES

- A. Finish: Manufacturer's standard prime-coat finish ready for field painting.
- B. Finish: Manufacturer's standard paint applied to factory-assembled and -tested equipment before shipping.
 1. Powder coating on springs and housings.
 2. All hardware shall be galvanized. Hot-dip galvanize metal components for exterior use.
 3. Baked enamel or powder coat for metal components on isolators for interior use.
 4. Color-code or otherwise mark vibration isolation and seismic-control devices to indicate capacity range.

PART 31 - EXECUTION

31.1 EXAMINATION

- A. Examine areas and equipment to receive vibration isolation and seismic-control devices for compliance with requirements for installation tolerances and other conditions affecting performance.
- B. Examine roughing-in of reinforcement and cast-in-place anchors to verify actual locations before installation.
- C. Proceed with installation only after unsatisfactory conditions have been corrected.

31.2 APPLICATIONS

- A. Multiple Pipe Supports: Secure pipes to trapeze member with clamps approved for application by an evaluation service member of ICC-ES.
- B. Hanger Rod Stiffeners: Install hanger rod stiffeners where indicated or scheduled on Drawings to receive them and where required to prevent buckling of hanger rods due to seismic forces.
- C. Strength of Support and Seismic-Restraint Assemblies: Where not indicated, select sizes of components so strength will be adequate to carry present and future static and seismic loads within specified loading limits.

31.3 VIBRATION-CONTROL AND SEISMIC-RESTRAINT DEVICE INSTALLATION

- A. Piping Restraints:
 - 1. Comply with requirements in MSS SP-127.
 - 2. Space lateral supports a maximum of **40 feet** o.c., and longitudinal supports a maximum of **80 feet** o.c.
 - 3. Brace a change of direction longer than **12 feet**.
- B. Install cables so they do not bend across edges of adjacent equipment or building structure.
- C. Install seismic-restraint devices using methods approved by an evaluation service member of ICC-ES providing required submittals for component.
- D. Install bushing assemblies for anchor bolts for floor-mounted equipment, arranged to provide resilient media between anchor bolt and mounting hole in concrete base.
- E. Install bushing assemblies for mounting bolts for wall-mounted equipment, arranged to provide resilient media where equipment or equipment-mounting channels are attached to wall.
- F. Attachment to Structure: If specific attachment is not indicated, anchor bracing to structure at flanges of beams, at upper truss chords of bar joists, or at concrete members.
- G. Drilled-in Anchors:

1. Identify position of reinforcing steel and other embedded items prior to drilling holes for anchors. Do not damage existing reinforcing or embedded items during coring or drilling. Notify the structural engineer if reinforcing steel or other embedded items are encountered during drilling. Locate and avoid prestressed tendons, electrical and telecommunications conduit, and gas lines.
2. Do not drill holes in concrete or masonry until concrete, mortar, or grout has achieved full design strength.
3. Wedge Anchors: Protect threads from damage during anchor installation. Heavy-duty sleeve anchors shall be installed with sleeve fully engaged in the structural element to which anchor is to be fastened.
4. Adhesive Anchors: Clean holes to remove loose material and drilling dust prior to installation of adhesive. Place adhesive in holes proceeding from the bottom of the hole and progressing toward the surface in such a manner as to avoid introduction of air pockets in the adhesive.
5. Set anchors to manufacturer's recommended torque, using a torque wrench.
6. Install zinc-coated steel anchors for interior and stainless-steel anchors for exterior applications.

31.4 ACCOMMODATION OF DIFFERENTIAL SEISMIC MOTION

- A. Install flexible connections in piping where they cross seismic joints, where adjacent sections or branches are supported by different structural elements, and where the connections terminate with connection to equipment that is anchored to a different structural element from the one supporting the connections as they approach equipment. Comply with requirements in Division 22 Section "Domestic Water Piping" for piping flexible connections.

31.5 FIELD QUALITY CONTROL

- A. Testing Agency: Owner will engage qualified testing agency to perform tests.
- B. Perform tests and inspections.
- C. Tests and Inspections:
 1. Provide evidence of recent calibration of test equipment by a testing agency acceptable to authorities having jurisdiction.
 2. Schedule test with Owner, through Architect, before connecting anchorage device to restrained component (unless post connection testing has been approved), and with at least seven days' advance notice.
 3. Obtain Architect's approval before transmitting test loads to structure. Provide temporary load-spreading members.
 4. Test at least four of each type and size of installed anchors and fasteners selected by Architect.
 5. Test to 90 percent of rated proof load of device.
 6. Measure isolator restraint clearance.
 7. Verify snubber minimum clearances.
 8. Air-Mounting System Leak Test: After installation, charge system and test for leaks. Repair leaks and retest until no leaks exist.
 9. Air-Mounting System Operational Test: Test the compressed-air leveling system.
 10. Test and adjust air-mounting system controls and safeties.

11. If a device fails test, modify all installations of same type and retest until satisfactory results are achieved.

D. Remove and replace malfunctioning units and retest as specified above.

E. Prepare test and inspection reports.

31.6 ADJUSTING

A. Adjust isolators after piping system is at operating weight.

B. Adjust limit stops on restrained spring isolators to mount equipment at normal operating height. After equipment installation is complete, adjust limit stops so they are out of contact during normal operation.

C. Adjust active height of sprint isolators.

D. Adjust restraints to permit free movement of equipment within normal mode of operation.

END OF SECTION

SECTION 220553 - IDENTIFICATION FOR PLUMBING PIPING AND EQUIPMENT

PART 33 - GENERAL

33.1 RELATED DOCUMENTS

- A. Drawings and general provisions of the Contract, including General and Supplementary Conditions and Division 01 Specification Sections, apply to this Section.

33.2 SUMMARY

- A. Section Includes:
 - 1. Equipment labels.
 - 2. Warning signs and labels.
 - 3. Pipe labels.
 - 4. Valve tags.
 - 5. Warning tags.

33.3 SUBMITTALS

- A. Product Data: For each type of product indicated.
- B. Samples: For color, letter style, and graphic representation required for each identification material and device.
- C. Equipment Label Schedule: Include a listing of all equipment to be labeled with the proposed content for each label.
- D. Valve numbering scheme.
- E. Valve Schedules: For each piping system to include in maintenance manuals.

33.4 COORDINATION

- A. Coordinate installation of identifying devices with completion of covering and painting of surfaces where devices are to be applied.
- B. Coordinate installation of identifying devices with locations of access panels and doors.
- C. Install identifying devices before installing acoustical ceilings and similar concealment.

PART 34 - PRODUCTS

34.1 EQUIPMENT LABELS

- A. Plastic Labels for Equipment:

1. Material and Thickness: Multilayer, multicolor, plastic labels for mechanical engraving, **1/16 inch (1.6 mm)** thick, and having predrilled holes for attachment hardware.
 2. Letter Color: Black
 3. Background Color: White
 4. Maximum Temperature: Able to withstand temperatures up to **160 deg F (71 deg C)**.
 5. Minimum Label Size: Length and width vary for required label content, but not less than **2-1/2 by 3/4 inch (64 by 19 mm)**.
 6. Minimum Letter Size: **1/4 inch (6.4 mm)** for name of units if viewing distance is less than **24 inches (600 mm)**, **1/2 inch (13 mm)** for viewing distances up to **72 inches (1830 mm)**, and proportionately larger lettering for greater viewing distances. Include secondary lettering two-thirds to three-fourths the size of principal lettering.
 7. Fasteners: Stainless-steel rivets.
 8. Adhesive: Contact-type permanent adhesive, compatible with label and with substrate.
- B. Label Content: Include equipment's Drawing designation or unique equipment number, Drawing numbers where equipment is indicated (plans, details, and schedules), plus the Specification Section number and title where equipment is specified.
- C. Equipment Label Schedule: For each item of equipment to be labeled, on **8-1/2-by-11-inch (A4)** bond paper. Tabulate equipment identification number and identify Drawing numbers where equipment is indicated (plans, details, and schedules), plus the Specification Section number and title where equipment is specified. Equipment schedule shall be included in operation and maintenance data.

34.2 WARNING SIGNS AND LABELS

- A. Material and Thickness: Multilayer, multicolor, plastic labels for mechanical engraving, **1/16 inch (1.6 mm)** thick, and having predrilled holes for attachment hardware.
- B. Letter Color: Red
- C. Background Color: White
- D. Maximum Temperature: Able to withstand temperatures up to **160 deg F (71 deg C)**.
- E. Minimum Label Size: Length and width vary for required label content, but not less than **2-1/2 by 3/4 inch (64 by 19 mm)**.
- F. Minimum Letter Size: **1/4 inch (6.4 mm)** for name of units if viewing distance is less than **24 inches (600 mm)**, **1/2 inch (13 mm)** for viewing distances up to **72 inches (1830 mm)**, and proportionately larger lettering for greater viewing distances. Include secondary lettering two-thirds to three-fourths the size of principal lettering.
- G. Fasteners: Stainless-steel rivets
- H. Adhesive: Contact-type permanent adhesive, compatible with label and with substrate.
- I. Label Content: Include caution and warning information, plus emergency notification instructions.

34.3 PIPE LABELS

- A. General Requirements for Manufactured Pipe Labels: Preprinted, color-coded, with lettering indicating service, and showing flow direction.
- B. Pretensioned Pipe Labels: Precoiled, semirigid plastic formed to cover full circumference of pipe and to attach to pipe without fasteners or adhesive.
- C. Self-Adhesive Pipe Labels: Printed plastic with contact-type, permanent-adhesive backing.
- D. Pipe Label Contents: Include identification of piping service using same designations or abbreviations as used on Drawings, pipe size, and an arrow indicating flow direction.
 - 1. Flow-Direction Arrows: Integral with piping system service lettering to accommodate both directions, or as separate unit on each pipe label to indicate flow direction.
 - 2. Lettering Size: At least **1-1/2 inches (38 mm)** high.

34.4 VALVE TAGS

- A. Valve Tags: Stamped or engraved with **1/4-inch (6.4-mm)** letters for piping system abbreviation and **1/2-inch (13-mm)** numbers.
 - 1. Tag Material: Brass, **0.032-inch (0.8-mm)** minimum thickness, and having predrilled or stamped holes for attachment hardware.
 - 2. Fasteners: Brass wire-link or beaded chain; or S-hook
- B. Valve Schedules: For each piping system, on **8-1/2-by-11-inch (A4)** bond paper. Tabulate valve number, piping system, system abbreviation (as shown on valve tag), location of valve (room or space), normal-operating position (open, closed, or modulating), and variations for identification. Mark valves for emergency shutoff and similar special uses.
 - 1. Valve-tag schedule shall be included in operation and maintenance data.

34.5 WARNING TAGS

- A. Warning Tags: Preprinted or partially preprinted, accident-prevention tags, of plasticized card stock with matte finish suitable for writing.
 - 1. Size: **3 by 5-1/4 inches (75 by 133 mm)** minimum
 - 2. Fasteners: Brass grommet and wire
 - 3. Nomenclature: Large-size primary caption such as "DANGER," "CAUTION," or "DO NOT OPERATE."
 - 4. Color: Yellow background with black lettering.

PART 35 - EXECUTION

35.1 PREPARATION

- A. Clean piping and equipment surfaces of substances that could impair bond of identification devices, including dirt, oil, grease, release agents, and incompatible primers, paints, and encapsulants.

35.2 EQUIPMENT LABEL INSTALLATION

- A. Install or permanently fasten labels on each major item of mechanical equipment.
- B. Locate equipment labels where accessible and visible.

35.3 PIPE LABEL INSTALLATION

- A. Piping Color-Coding: Painting of piping is specified in Section 099600 "High-Performance Coating."
- B. Locate pipe labels where piping is exposed or above accessible ceilings in finished spaces; machine rooms; accessible maintenance spaces such as shafts, tunnels, and plenums; and exterior exposed locations as follows:
 - 1. Near each valve and control device.
 - 2. Near each branch connection, excluding short takeoffs for fixtures and terminal units. Where flow pattern is not obvious, mark each pipe at branch.
 - 3. Near penetrations through walls, floors, ceilings, and inaccessible enclosures.
 - 4. At access doors, manholes, and similar access points that permit view of concealed piping.
 - 5. Near major equipment items and other points of origination and termination.
 - 6. Spaced at maximum intervals of **50 feet (15 m)** along each run. Reduce intervals to **25 feet (7.6 m)** in areas of congested piping and equipment.
 - 7. On piping above removable acoustical ceilings. Omit intermediately spaced labels.
- C. Pipe Label Color Schedule:
 - 1. Domestic Water Piping:
 - a. Background Color: Blue
 - b. Letter Color: White
 - 2. Sanitary Waste Piping:
 - a. Background Color: White.
 - b. Letter Color: Black

35.4 VALVE-TAG INSTALLATION

- A. Install tags on valves and control devices in piping systems, except check valves; valves within factory-fabricated equipment units; shutoff valves; faucets; convenience and lawn-

watering hose connections; and similar roughing-in connections of end-use fixtures and units. List tagged valves in a valve schedule.

B. Valve-Tag Application Schedule: Tag valves according to size, shape, and color scheme and with captions similar to those indicated in the following subparagraphs:

1. Valve-Tag Size and Shape:

- a. Cold Water: 1-1/2 inches (38 mm), round.
- b. Hot Water: 1-1/2 inches (38 mm), round.

2. Valve-Tag Color:

- a. Cold Water: Natural.
- b. Hot Water: Natural

3. Letter Color:

- a. Cold Water: Black
- b. Hot Water: Black

35.5 WARNING-TAG INSTALLATION

A. Write required message on, and attach warning tags to, equipment and other items where required.

END OF SECTION

SECTION 220719 - PLUMBING PIPING INSULATION

PART 37 - GENERAL

37.1 RELATED DOCUMENTS

- A. Drawings and general provisions of the Contract, including General and Supplementary Conditions and Division 01 Specification Sections, apply to this Section.

37.2 SUMMARY

- A. Section includes insulating the following plumbing piping services:
 1. Domestic hot-water piping.
 2. Domestic recirculating hot-water piping.
 3. Supplies and drains for handicap-accessible lavatories and sinks.

37.3 SUBMITTALS

- A. Product Data: For each type of product indicated. Include thermal conductivity, water-vapor permeance thickness, and jackets (both factory- and field-applied, if any).
- B. LEED Submittals:
 1. Product Data for Credit EQ 4.1: For adhesives and sealants, documentation including printed statement of VOC content and chemical components.
 2. Laboratory Test Reports for Credit EQ 4: For adhesives and sealants, documentation indicating that product complies with the testing and product requirements of the California Department of Health Services' "Standard Practice for the Testing of Volatile Organic Emissions from Various Sources Using Small-Scale Environmental Chambers," including 2004 Addenda.
- C. Shop Drawings: Include plans, elevations, sections, details, and attachments to other work.
 1. Detail application of protective shields, saddles, and inserts at hangers for each type of insulation and hanger.
 2. Detail attachment and covering of heat tracing inside insulation.
 3. Detail insulation application at pipe expansion joints for each type of insulation.
 4. Detail insulation application at elbows, fittings, flanges, valves, and specialties for each type of insulation.
 5. Detail removable insulation at piping specialties, equipment connections, and access panels.
 6. Detail application of field-applied jackets.
 7. Detail application at linkages of control devices.

- D. Samples: For each type of insulation and jacket indicated. Identify each Sample, describing product and intended use. Sample sizes are as follows:
 - 1. Preformed Pipe Insulation Materials: 12 inches (300 mm) long by NPS 2 (DN 50).
 - 2. Jacket Materials for Pipe: 12 inches (300 mm) long by NPS 2 (DN 50).
 - 3. Sheet Jacket Materials: 12 inches (300 mm) square. Manufacturer's Color Charts: For products where color is specified, show the full range of colors available for each type of finish material.
- E. Qualification Data: For qualified Installer.
- F. Material Test Reports: From a qualified testing agency acceptable to authorities having jurisdiction indicating, interpreting, and certifying test results for compliance of insulation materials, sealers, attachments, cements, and jackets, with requirements indicated. Include dates of tests and test methods employed.
- G. Field quality-control reports.

37.4 QUALITY ASSURANCE

- A. Installer Qualifications: Skilled mechanics who have successfully completed an apprenticeship program or another craft training program certified by the Department of Labor, Bureau of Apprenticeship and Training.
- B. Surface-Burning Characteristics: For insulation and related materials, as determined by testing identical products according to ASTM E 84 by a testing agency acceptable to authorities having jurisdiction. Factory label insulation and jacket materials and adhesive, mastic, tapes, and cement material containers, with appropriate markings of applicable testing agency.
 - 1. Insulation Installed Indoors: Flame-spread index of 25 or less, and smoke-developed index of 50 or less.
 - 2. Insulation Installed Outdoors: Flame-spread index of 75 or less, and smoke-developed index of 150 or less.
- C. Mockups: Before installing insulation, build mockups for each type of insulation and finish listed below to demonstrate quality of insulation application and finishes. Build mockups in the location indicated or, if not indicated, as directed by Architect. Use materials indicated for the completed Work.
 - 1. Piping Mockups:
 - a. One 10-foot (3-m) section of NPS 2 (DN 50) straight pipe.
 - b. One each of a 90-degree threaded, welded, and flanged elbow.
 - c. One each of a threaded, welded, and flanged tee fitting.
 - d. One NPS 2 (DN 50) or smaller valve, and one NPS 2-1/2 (DN 65) or larger valve.
 - e. Four support hangers including hanger shield and insert.
 - f. One threaded strainer and one flanged strainer with removable portion of insulation.
 - g. One threaded reducer and one welded reducer.

- h. One pressure temperature tap.
 - i. One mechanical coupling.
2. For each mockup, fabricate cutaway sections to allow observation of application details for insulation materials, adhesives, mastics, attachments, and jackets.
 3. Notify Architect seven days in advance of dates and times when mockups will be constructed.
 4. Obtain Architect's approval of mockups before starting insulation application.
 5. Approval of mockups does not constitute approval of deviations from the Contract Documents contained in mockups unless Architect specifically approves such deviations in writing.
 6. Maintain mockups during construction in an undisturbed condition as a standard for judging the completed Work.
 7. Demolish and remove mockups when directed.
- D. Comply with the following applicable standards and other requirements specified for miscellaneous components:
1. Supply and Drain Protective Shielding Guards: ICC A117.1.

37.5 DELIVERY, STORAGE, AND HANDLING

- A. Packaging: Insulation material containers shall be marked by manufacturer with appropriate ASTM standard designation, type and grade, and maximum use temperature.

37.6 COORDINATION

- A. Coordinate sizes and locations of supports, hangers, and insulation shields specified in Division 22 Section "Hangers and Supports for Plumbing Piping and Equipment."
- B. Coordinate clearance requirements with piping Installer for piping insulation application. Before preparing piping Shop Drawings, establish and maintain clearance requirements for installation of insulation and field-applied jackets and finishes and for space required for maintenance.
- C. Coordinate installation and testing of heat tracing.

37.7 SCHEDULING

- A. Schedule insulation application after pressure testing systems and, where required, after installing and testing heat tracing. Insulation application may begin on segments that have satisfactory test results.
- B. Complete installation and concealment of plastic materials as rapidly as possible in each area of construction.

PART 38 - PRODUCTS

38.1 INSULATION MATERIALS

- A. Comply with requirements in "Piping Insulation Schedule, General," "Indoor Piping Insulation Schedule," "Outdoor, Aboveground Piping Insulation Schedule," and "Outdoor, Underground Piping Insulation Schedule" articles for where insulating materials shall be applied.
- B. Products shall not contain asbestos, lead, mercury, or mercury compounds.
- C. Products that come in contact with stainless steel shall have a leachable chloride content of less than 50 ppm when tested according to ASTM C 871.
- D. Insulation materials for use on austenitic stainless steel shall be qualified as acceptable according to ASTM C 795.
- E. Foam insulation materials shall not use CFC or HCFC blowing agents in the manufacturing process.
- F. Cellular Glass: Inorganic, incombustible, foamed or cellulated glass with annealed, rigid, hermetically sealed cells. Factory-applied jacket requirements are specified in "Factory-Applied Jackets" Article.
 - 1. Products: Subject to compliance with requirements, provide the following
 - a. Pittsburgh Corning Corporation; Foamglas.
 - 2. Block Insulation: ASTM C 552, Type I.
 - 3. Special-Shaped Insulation: ASTM C 552, Type III.
 - 4. Preformed Pipe Insulation without Jacket: Comply with ASTM C 552, Type II, Class 1.
 - 5. Preformed Pipe Insulation with Factory-Applied [ASJ] [ASJ-SSL]: Comply with ASTM C 552, Type II, Class 2.
 - 6. Factory fabricate shapes according to ASTM C 450 and ASTM C 585.
- G. Mineral-Fiber Blanket Insulation: Mineral or glass fibers bonded with a thermosetting resin. Comply with ASTM C 553, Type II and ASTM C 1290, Type I. Factory-applied jacket requirements are specified in "Factory-Applied Jackets" Article.
 - 1. Products: Subject to compliance with requirements, provide the following:
 - a. CertainTeed Corp.; SoftTouch Duct Wrap.
 - b. Johns Manville; Microlite.
 - c. Knauf Insulation; Friendly Feel Duct Wrap.
 - d. Manson Insulation Inc.; Alley Wrap.
 - e. Owens Corning; SOFTR All-Service Duct Wrap.
- H. Mineral-Fiber, Preformed Pipe Insulation:
 - 1. Products: Subject to compliance with requirements, provide the following:
 - a. Fibrex Insulations Inc.; Coreplus 1200.

- b. Johns Manville; Micro-Lok.
 - c. Knauf Insulation; 1000-Degree Pipe Insulation.
 - d. Manson Insulation Inc.; Alley-K.
 - e. Owens Corning; Fiberglas Pipe Insulation.
2. Type I, **850 Deg F (454 Deg C)** Materials: Mineral or glass fibers bonded with a thermosetting resin. Comply with ASTM C 547, Type I, Grade A, with factory-applied ASJ-SSL. Factory-applied jacket requirements are specified in "Factory-Applied Jackets" Article.

38.2 INSULATING CEMENTS

- A. Mineral-Fiber Insulating Cement: Comply with ASTM C 195.
 - 1. Products: Subject to compliance with requirements, provide the following:
 - a. Ramco Insulation, Inc.; Super-Stik.
- B. Expanded or Exfoliated Vermiculite Insulating Cement: Comply with ASTM C 196.
 - 1. Products: Subject to compliance with requirements, provide the following:
 - a. Ramco Insulation, Inc.; Thermokote V.
- C. Mineral-Fiber, Hydraulic-Setting Insulating and Finishing Cement: Comply with ASTM C 449.
 - 1. Products: Subject to compliance with requirements, provide the following:
 - a. Ramco Insulation, Inc.; Ramcote 1200 and Quik-Cote.

38.3 ADHESIVES

- A. Materials shall be compatible with insulation materials, jackets, and substrates and for bonding insulation to itself and to surfaces to be insulated, unless otherwise indicated.
- B. Cellular-Glass Adhesive: Two-component, thermosetting urethane adhesive containing no flammable solvents, with a service temperature range of **minus 100 to plus 200 deg F (minus 73 to plus 93 deg C)**.
 - 1. Products: Subject to compliance with requirements, provide the following:
 - a. Foster Brand, Specialty Construction Brands, Inc., a business of H. B. Fuller Company; 81-84.
 - 2. For indoor applications, use adhesive that has a VOC content of 50 g/L or less when calculated according to 40 CFR 59, Subpart D (EPA Method 24).
 - 3. Use adhesive that complies with the testing and product requirements of the California Department of Health Services' "Standard Practice for the Testing of Volatile Organic Emissions from Various Sources Using Small-Scale Environmental Chambers," including 2004 Addenda.

- C. Mineral-Fiber Adhesive: Comply with MIL-A-3316C, Class 2, Grade A.
1. Products: Subject to compliance with requirements, provide the following:
 - a. Childers Brand, Specialty Construction Brands, Inc., a business of H. B. Fuller Company; CP-127.
 - b. Eagle Bridges - Marathon Industries; 225.
 - c. Foster Brand, Specialty Construction Brands, Inc., a business of H. B. Fuller Company; 85-60/85-70.
 - d. Mon-Eco Industries, Inc.; 22-25.
 2. For indoor applications, use adhesive that has a VOC content of 80 g/L or less when calculated according to 40 CFR 59, Subpart D (EPA Method 24).
 3. Use adhesive that complies with the testing and product requirements of the California Department of Health Services' "Standard Practice for the Testing of Volatile Organic Emissions from Various Sources Using Small-Scale Environmental Chambers," including 2004 Addenda.
- D. ASJ Adhesive, and FSK Jacket Adhesive: Comply with MIL-A-3316C, Class 2, Grade A for bonding insulation jacket lap seams and joints.
1. Products: Subject to compliance with requirements, provide the following:
 - a. Childers Brand, Specialty Construction Brands, Inc., a business of H. B. Fuller Company; CP-82.
 - b. Eagle Bridges - Marathon Industries; 225.
 - c. Foster Brand, Specialty Construction Brands, Inc., a business of H. B. Fuller Company; 85-20.
 - d. Mon-Eco Industries, Inc.; 22-25.
 2. For indoor applications, use adhesive that has a VOC content of 50 g/L or less when calculated according to 40 CFR 59, Subpart D (EPA Method 24).
 3. Use adhesive that complies with the testing and product requirements of the California Department of Health Services' "Standard Practice for the Testing of Volatile Organic Emissions from Various Sources Using Small-Scale Environmental Chambers," including 2004 Addenda.
- E. PVC Jacket Adhesive: Compatible with PVC jacket.
1. Products: Subject to compliance with requirements, provide the following:
 - a. Dow Corning Corporation; 739, Dow Silicone.
 - b. Johns Manville; Zeston Perma-Weld, CEEL-TITE Solvent Welding Adhesive.
 - c. P.I.C. Plastics, Inc.; Welding Adhesive.
 - d. Speedline Corporation; Polyco VP Adhesive.
 2. For indoor applications, use adhesive that has a VOC content of 50 g/L or less when calculated according to 40 CFR 59, Subpart D (EPA Method 24).
 3. Use adhesive that complies with the testing and product requirements of the California Department of Health Services' "Standard Practice for the Testing of Volatile Organic Emissions from Various Sources Using Small-Scale Environmental Chambers," including 2004 Addenda.

38.4 LAGGING ADHESIVES

- A. Description: Comply with MIL-A-3316C, Class I, Grade A, and shall be compatible with insulation materials, jackets, and substrates.
1. For indoor applications, use lagging adhesives that have a VOC content of 50 g/L or less when calculated according to 40 CFR 59, Subpart D (EPA Method 24).
 2. Products: Subject to compliance with requirements, provide the following:
 - a. Childers Brand, Specialty Construction Brands, Inc., a business of H. B. Fuller Company; CP-50 AHV2.
 - b. Foster Brand, Specialty Construction Brands, Inc., a business of H. B. Fuller Company; 30-36.
 - c. Vimasco Corporation; 713 and 714
 3. Fire-resistant, water-based lagging adhesive and coating for use indoors to adhere fire-resistant lagging cloths over pipe insulation.
 4. Service Temperature Range: 0 to plus 180 deg F (Minus 18 to plus 82 deg C).
 5. Color: White.

38.5 SEALANTS

- A. Joint Sealants:
1. Joint Sealants for Cellular-Glass and Phenolic Products: Subject to compliance with requirements, provide the following:
 - a. Childers Brand, Specialty Construction Brands, Inc., a business of H. B. Fuller Company; CP-76.
 - b. Eagle Bridges - Marathon Industries; 405.
 - c. Foster Brand, Specialty Construction Brands, Inc., a business of H. B. Fuller Company; 30-45.
 - d. Mon-Eco Industries, Inc.; 44-05.
 - e. Pittsburgh Corning Corporation; Pittseal 444.
 2. Materials shall be compatible with insulation materials, jackets, and substrates.
 3. Permanently flexible, elastomeric sealant.
 4. Service Temperature Range: Minus 100 to plus 300 deg F (Minus 73 to plus 149 deg C).
 5. Color: White or gray.
 6. For indoor applications, use sealants that have a VOC content of 420 g/L or less when calculated according to 40 CFR 59, Subpart D (EPA Method 24).
 7. Use sealants that comply with the testing and product requirements of the California Department of Health Services' "Standard Practice for the Testing of Volatile Organic Emissions from Various Sources Using Small-Scale Environmental Chambers," including 2004 Addenda.
- B. FSK and Metal Jacket Flashing Sealants:
1. Products: Subject to compliance with requirements, provide the following:
 - a. Childers Brand, Specialty Construction Brands, Inc., a business of H. B. Fuller Company; CP-76.

- b. Eagle Bridges - Marathon Industries; 405.
 - c. Foster Brand, Specialty Construction Brands, Inc., a business of H. B. Fuller Company; 95-44.
 - d. Mon-Eco Industries, Inc.; 44-05.
2. Materials shall be compatible with insulation materials, jackets, and substrates.
 3. Fire- and water-resistant, flexible, elastomeric sealant.
 4. Service Temperature Range: **Minus 40 to plus 250 deg F (Minus 40 to plus 121 deg C)**.
 5. Color: Aluminum.
 6. For indoor applications, use sealants that have a VOC content of 420 g/L or less when calculated according to 40 CFR 59, Subpart D (EPA Method 24).
 7. Use sealants that comply with the testing and product requirements of the California Department of Health Services' "Standard Practice for the Testing of Volatile Organic Emissions from Various Sources Using Small-Scale Environmental Chambers," including 2004 Addenda.
- C. ASJ Flashing Sealants, and Vinyl, PVDC, and PVC Jacket Flashing Sealants:
1. Products: Subject to compliance with requirements, provide the following:
 - a. Childers Brand, Specialty Construction Brands, Inc., a business of H. B. Fuller Company; CP-76.
 2. Materials shall be compatible with insulation materials, jackets, and substrates.
 3. Fire- and water-resistant, flexible, elastomeric sealant.
 4. Service Temperature Range: **Minus 40 to plus 250 deg F (Minus 40 to plus 121 deg C)**.
 5. Color: White.
 6. For indoor applications, use sealants that have a VOC content of 420 g/L or less when calculated according to 40 CFR 59, Subpart D (EPA Method 24).
 7. Use sealants that comply with the testing and product requirements of the California Department of Health Services' "Standard Practice for the Testing of Volatile Organic Emissions from Various Sources Using Small-Scale Environmental Chambers," including 2004 Addenda.

38.6 FACTORY-APPLIED JACKETS

- A. Insulation system schedules indicate factory-applied jackets on various applications. When factory-applied jackets are indicated, comply with the following:
1. ASJ: White, kraft-paper, fiberglass-reinforced scrim with aluminum-foil backing; complying with ASTM C 1136, Type I.
 2. ASJ-SSL: ASJ with self-sealing, pressure-sensitive, acrylic-based adhesive covered by a removable protective strip; complying with ASTM C 1136, Type I.
 3. FSK Jacket: Aluminum-foil, fiberglass-reinforced scrim with kraft-paper backing; complying with ASTM C 1136, Type II.

38.7 FIELD-APPLIED FABRIC-REINFORCING MESH

- A. Woven Glass-Fiber Fabric: Approximately 2 oz./sq. yd. (68 g/sq. m) with a thread count of 10 strands by 10 strands/sq. in. (4 strands by 4 strands/sq. mm) for covering pipe and pipe fittings.
 - 1. Products: Subject to compliance with requirements, provide the following:
 - a. Childers Brand, Specialty Construction Brands, Inc., a business of H. B. Fuller Company; Chil-Glas Number 10.
- B. Woven Polyester Fabric: Approximately 1 oz./sq. yd. (34 g/sq. m) with a thread count of 10 strands by 10 strands/sq. in. (4 strands by 4 strands/sq. mm), in a Leno weave, for pipe.
 - 1. Products: Subject to compliance with requirements, provide the following:
 - a. Foster Brand, Specialty Construction Brands, Inc., a business of H. B. Fuller Company; Mast-A-Fab.
 - b. Vimasco Corporation; Elastafab 894.

38.8 FIELD-APPLIED CLOTHS

- A. Woven Glass-Fiber Fabric: Comply with MIL-C-20079H, Type I, plain weave, and presized a minimum of 8 oz./sq. yd. (271 g/sq. m).
 - 1. Products: Subject to compliance with requirements, provide the following:
 - a. Alpha Associates, Inc.; Alpha-Maritex 84215 and 84217/9485RW, Luben 59.

38.9 FIELD-APPLIED JACKETS

- A. Field-applied jackets shall comply with ASTM C 921, Type I, unless otherwise indicated.
- B. PVC Jacket: High-impact-resistant, UV-resistant PVC complying with ASTM D 1784, Class 16354-C; thickness as scheduled; roll stock ready for shop or field cutting and forming. Thickness is indicated in field-applied jacket schedules.
 - 1. Products: Subject to compliance with requirements, provide the following:
 - a. Johns Manville; Zeston.
 - b. P.I.C. Plastics, Inc.; FG Series.
 - c. Proto Corporation; LoSmoke.
 - d. Speedline Corporation; SmokeSafe.
 - 2. Adhesive: As recommended by jacket material manufacturer.
 - 3. Color: Color-code jackets based on system.
 - 4. Factory-fabricated fitting covers to match jacket if available; otherwise, field fabricate.
 - a. Shapes: 45- and 90-degree, short- and long-radius elbows, tees, valves, flanges, unions, reducers, end caps, soil-pipe hubs, traps, mechanical joints, and P-trap and supply covers for lavatories.

C. Metal Jacket:

1. Products: Subject to compliance with requirements, provide the following:
 - a. Childers Brand, Specialty Construction Brands, Inc., a business of H. B. Fuller Company; Metal Jacketing Systems.
 - b. ITW Insulation Systems; Aluminum and Stainless Steel Jacketing.
 - c. RPR Products, Inc.; Insul-Mate.

2. Aluminum Jacket: Comply with **ASTM B 209 (ASTM B 209M)**, Alloy 3003, 3005, 3105, or 5005, Temper H-14.
 - a. Sheet and roll stock ready for shop or field sizing.
 - b. Finish and thickness are indicated in field-applied jacket schedules.
 - c. Moisture Barrier for Indoor Applications: **1-mil- (0.025-mm-)** thick, heat-bonded polyethylene and kraft paper.
 - d. Moisture Barrier for Outdoor Applications: **3-mil- (0.075-mm-)** thick, heat-bonded polyethylene and kraft paper.
 - e. Factory-Fabricated Fitting Covers:
 - 1) Same material, finish, and thickness as jacket.
 - 2) Preformed 2-piece or gore, 45- and 90-degree, short- and long-radius elbows.
 - 3) Tee covers.
 - 4) Flange and union covers.
 - 5) End caps.
 - 6) Beveled collars.
 - 7) Valve covers.
 - 8) Field fabricate fitting covers only if factory-fabricated fitting covers are not available.

3. Stainless-Steel Jacket: ASTM A 167 or ASTM A 240/A 240M.
 - a. Sheet and roll stock ready for shop or field sizing.
 - b. Material, finish, and thickness are indicated in field-applied jacket schedules.
 - c. Moisture Barrier for Indoor Applications: **1-mil- (0.025-mm-)** thick, heat-bonded polyethylene and kraft paper.
 - d. Moisture Barrier for Outdoor Applications: **3-mil- (0.075-mm-)** thick, heat-bonded polyethylene and kraft paper.
 - e. Factory-Fabricated Fitting Covers:
 - 1) Same material, finish, and thickness as jacket.
 - 2) Preformed 2-piece or gore, 45- and 90-degree, short- and long-radius elbows.
 - 3) Tee covers.
 - 4) Flange and union covers.
 - 5) End caps.
 - 6) Beveled collars.
 - 7) Valve covers.
 - 8) Field fabricate fitting covers only if factory-fabricated fitting covers are not available.

D. Underground Direct-Buried Jacket: **125-mil- (3.2-mm-)** thick vapor barrier and waterproofing membrane consisting of a rubberized bituminous resin reinforced with a woven-glass fiber or polyester scrim and laminated aluminum foil.

1. Products: Subject to compliance with requirements, provide the following:
 - a. Pittsburgh Corning Corporation; Pittwrap.
 - b. Polyguard Products, Inc.; Insulrap No Torch 125.

38.10 TAPES

A. ASJ Tape: White vapor-retarder tape matching factory-applied jacket with acrylic adhesive, complying with ASTM C 1136.

1. Products: Subject to compliance with requirements, provide the following:
 - a. ABI, Ideal Tape Division; 428 AWF ASJ.
 - b. Avery Dennison Corporation, Specialty Tapes Division; Fasson 0836.
 - c. Compac Corporation; 104 and 105.
 - d. Venture Tape; 1540 CW Plus, 1542 CW Plus, and 1542 CW Plus/SQ.
2. Width: **3 inches (75 mm)**.
3. Thickness: **11.5 mils (0.29 mm)**.
4. Adhesion: **90 ounces force/inch (1.0 N/mm)** in width.
5. Elongation: 2 percent.
6. Tensile Strength: **40 lbf/inch (7.2 N/mm)** in width.
7. ASJ Tape Disks and Squares: Precut disks or squares of ASJ tape.

B. FSK Tape: Foil-face, vapor-retarder tape matching factory-applied jacket with acrylic adhesive; complying with ASTM C 1136.

1. Products: Subject to compliance with requirements, provide the following:
 - a. ABI, Ideal Tape Division; 491 AWF FSK.
 - b. Avery Dennison Corporation, Specialty Tapes Division; Fasson 0827.
 - c. Compac Corporation; 110 and 111.
 - d. Venture Tape; 1525 CW NT, 1528 CW, and 1528 CW/SQ.
2. Width: **3 inches (75 mm)**.
3. Thickness: **6.5 mils (0.16 mm)**.
4. Adhesion: **90 ounces force/inch (1.0 N/mm)** in width.
5. Elongation: 2 percent.
6. Tensile Strength: **40 lbf/inch (7.2 N/mm)** in width.
7. FSK Tape Disks and Squares: Precut disks or squares of FSK tape.

C. PVC Tape: White vapor-retarder tape matching field-applied PVC jacket with acrylic adhesive; suitable for indoor and outdoor applications.

1. Products: Subject to compliance with requirements, provide the following:
 - a. ABI, Ideal Tape Division; 370 White PVC tape.
 - b. Compac Corporation; 130.
 - c. Venture Tape; 1506 CW NS.

2. Width: **2 inches (50 mm)**.
3. Thickness: **6 mils (0.15 mm)**.
4. Adhesion: **64 ounces force/inch (0.7 N/mm)** in width.
5. Elongation: 500 percent.
6. Tensile Strength: **18 lbf/inch (3.3 N/mm)** in width.

D. Aluminum-Foil Tape: Vapor-retarder tape with acrylic adhesive.

1. Products: Subject to compliance with requirements, provide the following:
 - a. ABI, Ideal Tape Division; 488 AWF.
 - b. Avery Dennison Corporation, Specialty Tapes Division; Fasson 0800.
 - c. Compac Corporation; 120.
 - d. Venture Tape; 3520 CW.
2. Width: **2 inches (50 mm)**.
3. Thickness: **3.7 mils (0.093 mm)**.
4. Adhesion: **100 ounces force/inch (1.1 N/mm)** in width.
5. Elongation: 5 percent.
6. Tensile Strength: **34 lbf/inch (6.2 N/mm)** in width.

38.11 SECUREMENTS

A. Bands:

1. Products: Subject to compliance with requirements, provide the following:
 - a. ITW Insulation Systems; Gerrard Strapping and Seals.
 - b. RPR Products, Inc.; Insul-Mate Strapping and Seals.
2. Stainless Steel: ASTM A 167 or ASTM A 240/A 240M, Type 304 or Type 316; **0.015 inch (0.38 mm)** thick, **1/2 inch (13 mm)** wide with wing seal or closed seal.
3. Aluminum: **ASTM B 209 (ASTM B 209M)**, Alloy 3003, 3005, 3105, or 5005; Temper H-14, **0.020 inch (0.51 mm)** thick, **1/2 inch (13 mm)** wide with wing seal or closed seal.

B. Staples: Outward-clinching insulation staples, nominal **3/4-inch- (19-mm-)** wide, stainless steel or Monel.

C. Wire: **0.080-inch (2.0-mm)** nickel-copper alloy.

1. Manufacturers: Subject to compliance with requirements, provide products by one of the following:
 - a. C & F Wire.

38.12 PROTECTIVE SHIELDING GUARDS

A. Protective Shielding Pipe Covers,

1. Manufacturers: Subject to compliance with requirements, provide products by the following:

- a. Engineered Brass Company.
 - b. Insul-Tect Products Co.; a subsidiary of MVG Molded Products.
 - c. McGuire Manufacturing.
 - d. Plumberex.
 - e. Truebro; a brand of IPS Corporation.
 - f. Zurn Industries, LLC; Tubular Brass Plumbing Products Operation.
2. Description: Manufactured plastic wraps for covering plumbing fixture hot-water supply and trap and drain piping. Comply with Americans with Disabilities Act (ADA) requirements.
- B. Protective Shielding Piping Enclosures:
- 1. Manufacturers: Subject to compliance with requirements, provide products by the following:
 - a. Truebro; a brand of IPS Corporation.
 - b. Zurn Industries, LLC; Tubular Brass Plumbing Products Operation.
 - 2. Description: Manufactured plastic enclosure for covering plumbing fixture hot- and cold-water supplies and trap and drain piping. Comply with ADA requirements.

PART 39 - EXECUTION

39.1 EXAMINATION

- A. Examine substrates and conditions for compliance with requirements for installation tolerances and other conditions affecting performance of insulation application.
 - 1. Verify that systems to be insulated have been tested and are free of defects.
 - 2. Verify that surfaces to be insulated are clean and dry.
- B. Proceed with installation only after unsatisfactory conditions have been corrected.

39.2 PREPARATION

- A. Surface Preparation: Clean and dry surfaces to receive insulation. Remove materials that will adversely affect insulation application.
- B. Surface Preparation: Clean and prepare surfaces to be insulated. Before insulating, apply a corrosion coating to insulated surfaces as follows:
 - 1. Stainless Steel: Coat 300 series stainless steel with an epoxy primer **5 mils (0.127 mm)** thick and an epoxy finish **5 mils (0.127 mm)** thick if operating in a temperature range between **140 and 300 deg F (60 and 149 deg C)**. Consult coating manufacturer for appropriate coating materials and application methods for operating temperature range.
 - 2. Carbon Steel: Coat carbon steel operating at a service temperature between **32 and 300 deg F (0 and 149 deg C)** with an epoxy coating. Consult coating manufacturer for appropriate coating materials and application methods for operating temperature range.

- C. Coordinate insulation installation with the trade installing heat tracing. Comply with requirements for heat tracing that apply to insulation.
- D. Mix insulating cements with clean potable water; if insulating cements are to be in contact with stainless-steel surfaces, use demineralized water.

39.3 GENERAL INSTALLATION REQUIREMENTS

- A. Install insulation materials, accessories, and finishes with smooth, straight, and even surfaces; free of voids throughout the length of piping including fittings, valves, and specialties.
- B. Install insulation materials, forms, vapor barriers or retarders, jackets, and thicknesses required for each item of pipe system as specified in insulation system schedules.
- C. Install accessories compatible with insulation materials and suitable for the service. Install accessories that do not corrode, soften, or otherwise attack insulation or jacket in either wet or dry state.
- D. Install insulation with longitudinal seams at top and bottom of horizontal runs.
- E. Install multiple layers of insulation with longitudinal and end seams staggered.
- F. Do not weld brackets, clips, or other attachment devices to piping, fittings, and specialties.
- G. Keep insulation materials dry during application and finishing.
- H. Install insulation with tight longitudinal seams and end joints. Bond seams and joints with adhesive recommended by insulation material manufacturer.
- I. Install insulation with least number of joints practical.
- J. Where vapor barrier is indicated, seal joints, seams, and penetrations in insulation at hangers, supports, anchors, and other projections with vapor-barrier mastic.
 - 1. Install insulation continuously through hangers and around anchor attachments.
 - 2. For insulation application where vapor barriers are indicated, extend insulation on anchor legs from point of attachment to supported item to point of attachment to structure. Taper and seal ends at attachment to structure with vapor-barrier mastic.
 - 3. Install insert materials and install insulation to tightly join the insert. Seal insulation to insulation inserts with adhesive or sealing compound recommended by insulation material manufacturer.
 - 4. Cover inserts with jacket material matching adjacent pipe insulation. Install shields over jacket, arranged to protect jacket from tear or puncture by hanger, support, and shield.
- K. Apply adhesives, mastics, and sealants at manufacturer's recommended coverage rate and wet and dry film thicknesses.
- L. Install insulation with factory-applied jackets as follows:
 - 1. Draw jacket tight and smooth.

2. Cover circumferential joints with **3-inch- (75-mm-)** wide strips, of same material as insulation jacket. Secure strips with adhesive and outward clinching staples along both edges of strip, spaced **4 inches (100 mm)** o.c.
 3. Overlap jacket longitudinal seams at least **1-1/2 inches (38 mm)**. Install insulation with longitudinal seams at bottom of pipe. Clean and dry surface to receive self-sealing lap. Staple laps with outward clinching staples along edge at **2 inches (50 mm)** o.c.
 - a. For below-ambient services, apply vapor-barrier mastic over staples.
 4. Cover joints and seams with tape, according to insulation material manufacturer's written instructions, to maintain vapor seal.
 5. Where vapor barriers are indicated, apply vapor-barrier mastic on seams and joints and at ends adjacent to pipe flanges and fittings.
- M. Cut insulation in a manner to avoid compressing insulation more than 75 percent of its nominal thickness.
- N. Finish installation with systems at operating conditions. Repair joint separations and cracking due to thermal movement.
- O. Repair damaged insulation facings by applying same facing material over damaged areas. Extend patches at least **4 inches (100 mm)** beyond damaged areas. Adhere, staple, and seal patches similar to butt joints.
- P. For above-ambient services, do not install insulation to the following:
1. Vibration-control devices.
 2. Testing agency labels and stamps.
 3. Nameplates and data plates.
 4. Cleanouts.

39.4 PENETRATIONS

- A. Insulation Installation at Roof Penetrations: Install insulation continuously through roof penetrations.
1. Seal penetrations with flashing sealant.
 2. For applications requiring only indoor insulation, terminate insulation above roof surface and seal with joint sealant. For applications requiring indoor and outdoor insulation, install insulation for outdoor applications tightly joined to indoor insulation ends. Seal joint with joint sealant.
 3. Extend jacket of outdoor insulation outside roof flashing at least **2 inches (50 mm)** below top of roof flashing.
 4. Seal jacket to roof flashing with flashing sealant.
- B. Insulation Installation at Underground Exterior Wall Penetrations: Terminate insulation flush with sleeve seal. Seal terminations with flashing sealant.
- C. Insulation Installation at Aboveground Exterior Wall Penetrations: Install insulation continuously through wall penetrations.
1. Seal penetrations with flashing sealant.

2. For applications requiring only indoor insulation, terminate insulation inside wall surface and seal with joint sealant. For applications requiring indoor and outdoor insulation, install insulation for outdoor applications tightly joined to indoor insulation ends. Seal joint with joint sealant.
 3. Extend jacket of outdoor insulation outside wall flashing and overlap wall flashing at least **2 inches (50 mm)**.
 4. Seal jacket to wall flashing with flashing sealant.
- D. Insulation Installation at Interior Wall and Partition Penetrations (That Are Not Fire Rated): Install insulation continuously through walls and partitions.
- E. Insulation Installation at Fire-Rated Wall and Partition Penetrations: Install insulation continuously through penetrations of fire-rated walls and partitions.
- F. Insulation Installation at Floor Penetrations:
1. Pipe: Install insulation continuously through floor penetrations.

39.5 GENERAL PIPE INSULATION INSTALLATION

- A. Requirements in this article generally apply to all insulation materials except where more specific requirements are specified in various pipe insulation material installation articles.
- B. Insulation Installation on Fittings, Valves, Strainers, Flanges, and Unions:
1. Install insulation over fittings, valves, strainers, flanges, unions, and other specialties with continuous thermal and vapor-retarder integrity unless otherwise indicated.
 2. Insulate pipe elbows using preformed fitting insulation or mitered fittings made from same material and density as adjacent pipe insulation. Each piece shall be butted tightly against adjoining piece and bonded with adhesive. Fill joints, seams, voids, and irregular surfaces with insulating cement finished to a smooth, hard, and uniform contour that is uniform with adjoining pipe insulation.
 3. Insulate tee fittings with preformed fitting insulation or sectional pipe insulation of same material and thickness as used for adjacent pipe. Cut sectional pipe insulation to fit. Butt each section closely to the next and hold in place with tie wire. Bond pieces with adhesive.
 4. Insulate valves using preformed fitting insulation or sectional pipe insulation of same material, density, and thickness as used for adjacent pipe. Overlap adjoining pipe insulation by not less than two times the thickness of pipe insulation, or one pipe diameter, whichever is thicker. For valves, insulate up to and including the bonnets, valve stuffing-box studs, bolts, and nuts. Fill joints, seams, and irregular surfaces with insulating cement.
 5. Insulate strainers using preformed fitting insulation or sectional pipe insulation of same material, density, and thickness as used for adjacent pipe. Overlap adjoining pipe insulation by not less than two times the thickness of pipe insulation, or one pipe diameter, whichever is thicker. Fill joints, seams, and irregular surfaces with insulating cement. Insulate strainers so strainer basket flange or plug can be easily removed and replaced without damaging the insulation and jacket. Provide a

- removable reusable insulation cover. For below-ambient services, provide a design that maintains vapor barrier.
6. Insulate flanges and unions using a section of oversized preformed pipe insulation. Overlap adjoining pipe insulation by not less than two times the thickness of pipe insulation, or one pipe diameter, whichever is thicker.
 7. Cover segmented insulated surfaces with a layer of finishing cement and coat with a mastic. Install vapor-barrier mastic for below-ambient services and a breather mastic for above-ambient services. Reinforce the mastic with fabric-reinforcing mesh. Trowel the mastic to a smooth and well-shaped contour.
 8. For services not specified to receive a field-applied jacket except for flexible elastomeric and polyolefin, install fitted PVC cover over elbows, tees, strainers, valves, flanges, and unions. Terminate ends with PVC end caps. Tape PVC covers to adjoining insulation facing using PVC tape.
 9. Stencil or label the outside insulation jacket of each union with the word "union." Match size and color of pipe labels.
- C. Insulate instrument connections for thermometers, pressure gages, pressure temperature taps, test connections, flow meters, sensors, switches, and transmitters on insulated pipes. Shape insulation at these connections by tapering it to and around the connection with insulating cement and finish with finishing cement, mastic, and flashing sealant.
- D. Install removable insulation covers at locations indicated. Installation shall conform to the following:
1. Make removable flange and union insulation from sectional pipe insulation of same thickness as that on adjoining pipe. Install same insulation jacket as adjoining pipe insulation.
 2. When flange and union covers are made from sectional pipe insulation, extend insulation from flanges or union long at least two times the insulation thickness over adjacent pipe insulation on each side of flange or union. Secure flange cover in place with stainless-steel or aluminum bands. Select band material compatible with insulation and jacket.
 3. Construct removable valve insulation covers in same manner as for flanges, except divide the two-part section on the vertical center line of valve body.
 4. When covers are made from block insulation, make two halves, each consisting of mitered blocks wired to stainless-steel fabric. Secure this wire frame, with its attached insulation, to flanges with tie wire. Extend insulation at least **2 inches (50 mm)** over adjacent pipe insulation on each side of valve. Fill space between flange or union cover and pipe insulation with insulating cement. Finish cover assembly with insulating cement applied in two coats. After first coat is dry, apply and trowel second coat to a smooth finish.
 5. Unless a PVC jacket is indicated in field-applied jacket schedules, finish exposed surfaces with a metal jacket.

39.6 INSTALLATION OF CELLULAR-GLASS INSULATION

- A. Insulation Installation on Straight Pipes and Tubes:
1. Secure each layer of insulation to pipe with wire or bands and tighten bands without deforming insulation materials.
 2. Where vapor barriers are indicated, seal longitudinal seams, end joints, and protrusions with vapor-barrier mastic and joint sealant.

3. For insulation with factory-applied jackets on above-ambient services, secure laps with outward clinched staples at 6 inches (150 mm) o.c.
4. For insulation with factory-applied jackets on below-ambient services, do not staple longitudinal tabs. Instead, secure tabs with additional adhesive as recommended by insulation material manufacturer and seal with vapor-barrier mastic and flashing sealant.

B. Insulation Installation on Pipe Flanges:

1. Install preformed pipe insulation to outer diameter of pipe flange.
2. Make width of insulation section same as overall width of flange and bolts, plus twice the thickness of pipe insulation.
3. Fill voids between inner circumference of flange insulation and outer circumference of adjacent straight pipe segments with cut sections of cellular-glass block insulation of same thickness as pipe insulation.
4. Install jacket material with manufacturer's recommended adhesive, overlap seams at least 1 inch (25 mm), and seal joints with flashing sealant.

C. Insulation Installation on Pipe Fittings and Elbows:

1. Install preformed sections of same material as straight segments of pipe insulation when available. Secure according to manufacturer's written instructions.
2. When preformed sections of insulation are not available, install mitered sections of cellular-glass insulation. Secure insulation materials with wire or bands.

D. Insulation Installation on Valves and Pipe Specialties:

1. Install preformed sections of cellular-glass insulation to valve body.
2. Arrange insulation to permit access to packing and to allow valve operation without disturbing insulation.
3. Install insulation to flanges as specified for flange insulation application.

39.7 INSTALLATION OF MINERAL-FIBER INSULATION

A. Insulation Installation on Straight Pipes and Tubes:

1. Secure each layer of preformed pipe insulation to pipe with wire or bands and tighten bands without deforming insulation materials.
2. Where vapor barriers are indicated, seal longitudinal seams, end joints, and protrusions with vapor-barrier mastic and joint sealant.
3. For insulation with factory-applied jackets on above-ambient surfaces, secure laps with outward clinched staples at 6 inches (150 mm) o.c.
4. For insulation with factory-applied jackets on below-ambient surfaces, do not staple longitudinal tabs. Instead, secure tabs with additional adhesive as recommended by insulation material manufacturer and seal with vapor-barrier mastic and flashing sealant.

B. Insulation Installation on Pipe Flanges:

1. Install preformed pipe insulation to outer diameter of pipe flange.
2. Make width of insulation section same as overall width of flange and bolts, plus twice the thickness of pipe insulation.

3. Fill voids between inner circumference of flange insulation and outer circumference of adjacent straight pipe segments with mineral-fiber blanket insulation.
4. Install jacket material with manufacturer's recommended adhesive, overlap seams at least **1 inch (25 mm)**, and seal joints with flashing sealant.

C. Insulation Installation on Pipe Fittings and Elbows:

1. Install preformed sections of same material as straight segments of pipe insulation when available.
2. When preformed insulation elbows and fittings are not available, install mitered sections of pipe insulation, to a thickness equal to adjoining pipe insulation. Secure insulation materials with wire or bands.

D. Insulation Installation on Valves and Pipe Specialties:

1. Install preformed sections of same material as straight segments of pipe insulation when available.
2. When preformed sections are not available, install mitered sections of pipe insulation to valve body.
3. Arrange insulation to permit access to packing and to allow valve operation without disturbing insulation.
4. Install insulation to flanges as specified for flange insulation application.

39.8 FIELD-APPLIED JACKET INSTALLATION

A. Where glass-cloth jackets are indicated, install directly over bare insulation or insulation with factory-applied jackets.

1. Draw jacket smooth and tight to surface with **2-inch (50-mm)** overlap at seams and joints.
2. Embed glass cloth between two **0.062-inch- (1.6-mm-)** thick coats of lagging adhesive.
3. Completely encapsulate insulation with coating, leaving no exposed insulation.

B. Where FSK jackets are indicated, install as follows:

1. Draw jacket material smooth and tight.
2. Install lap or joint strips with same material as jacket.
3. Secure jacket to insulation with manufacturer's recommended adhesive.
4. Install jacket with **1-1/2-inch (38-mm)** laps at longitudinal seams and **3-inch- (75-mm-)** wide joint strips at end joints.
5. Seal openings, punctures, and breaks in vapor-retarder jackets and exposed insulation with vapor-barrier mastic.

C. Where PVC jackets are indicated, install with **1-inch (25-mm)** overlap at longitudinal seams and end joints. Seal with manufacturer's recommended adhesive.

1. Apply two continuous beads of adhesive to seams and joints, one bead under lap and the finish bead along seam and joint edge.

D. Where metal jackets are indicated, install with **2-inch (50-mm)** overlap at longitudinal seams and end joints. Overlap longitudinal seams arranged to shed water. Seal end joints with

weatherproof sealant recommended by insulation manufacturer. Secure jacket with stainless-steel bands **12 inches (300 mm)** o.c. and at end joints.

39.9 FINISHES

- A. Insulation with ASJ, Glass-Cloth, or Other Paintable Jacket Material: Paint jacket with paint system identified below and as specified in Division 09 painting Sections.
 - 1. Flat Acrylic Finish: Two finish coats over a primer that is compatible with jacket material and finish coat paint. Add fungicidal agent to render fabric mildew proof.
 - a. Finish Coat Material: Interior, flat, latex-emulsion size.
- B. Flexible Elastomeric Thermal Insulation: After adhesive has fully cured, apply two coats of insulation manufacturer's recommended protective coating.
- C. Color: Final color as selected by Architect. Vary first and second coats to allow visual inspection of the completed Work.
- D. Do not field paint aluminum or stainless-steel jackets.

39.10 FIELD QUALITY CONTROL

- A. Testing Agency: Owner will engage a qualified testing agency to perform tests and inspections.
- B. Perform tests and inspections.
- C. Tests and Inspections:
 - 1. Inspect pipe, fittings, strainers, and valves, randomly selected by Architect, by removing field-applied jacket and insulation in layers in reverse order of their installation. Extent of inspection shall be limited to three locations of straight pipe, three locations of threaded fittings, three locations of welded fittings, two locations of threaded strainers, two locations of welded strainers, three locations of threaded valves, and three locations of flanged valves for each pipe service defined in the "Piping Insulation Schedule, General" Article.
- D. All insulation applications will be considered defective Work if sample inspection reveals noncompliance with requirements.

39.11 PIPING INSULATION SCHEDULE, GENERAL

- A. Acceptable preformed pipe and tubular insulation materials and thicknesses are identified for each piping system and pipe size range. If more than one material is listed for a piping system, selection from materials listed is Contractor's option.
- B. Items Not Insulated: Unless otherwise indicated, do not install insulation on the following:
 - 1. Drainage piping located in crawl spaces.
 - 2. Underground piping.
 - 3. Chrome-plated pipes and fittings unless there is a potential for personnel injury.

39.12 INDOOR PIPING INSULATION SCHEDULE

A. Domestic Hot and Recirculated Hot Water:

1. **NPS 1-1/4 (DN 32)** and Smaller: Insulation shall be the following:
 - a. Mineral-Fiber, Preformed Pipe Insulation, Type I: **1 inch (13 mm)** thick.
2. **NPS 1-1/2 (DN 40)** and Larger: Insulation shall be the following:
 - a. Mineral-Fiber, Preformed Pipe Insulation, Type I: **1 inch (25 mm)** thick.

B. Exposed Sanitary Drains, Domestic Water, Domestic Hot Water, and Stops for Plumbing Fixtures for People with Disabilities:

1. All Pipe Sizes: Insulation shall be the following:
 - a. Flexible Elastomeric: **1/2 inch (13 mm)** thick.
 - b. Mineral-Fiber, Preformed Pipe Insulation, Type I: **1/2 inch (13 mm)** thick.
 - c. Polyolefin: **1/2 inch (13 mm)** thick.

39.13 OUTDOOR, ABOVEGROUND PIPING INSULATION SCHEDULE

A. Domestic Water Piping:

1. All Pipe Sizes: Insulation shall be one of the following:
 - a. Cellular Glass: **2 inches (50 mm)** thick.
 - b. Mineral-Fiber, Preformed Pipe Insulation, Type I: **2 inches (50 mm)** thick.

B. Domestic Hot and Recirculated Hot Water:

1. All Pipe Sizes: Insulation shall be one of the following:
 - a. Cellular Glass: **2 inches (50 mm)** thick.
 - b. Mineral-Fiber, Preformed Pipe Insulation, Type I: **2 inches (50 mm)** thick.

39.14 INDOOR, FIELD-APPLIED JACKET SCHEDULE

A. Install jacket over insulation material. For insulation with factory-applied jacket, install the field-applied jacket over the factory-applied jacket.

B. If more than one material is listed, selection from materials listed is Contractor's option.

C. Piping, Concealed:

1. None.
2. PVC : **20 mils (0.5 mm)** thick.

D. Piping, Exposed:

1. None.

2. PVC: 20 mils (0.5 mm) thick.

39.15 OUTDOOR, FIELD-APPLIED JACKET SCHEDULE

- A. Install jacket over insulation material. For insulation with factory-applied jacket, install the field-applied jacket over the factory-applied jacket.
- B. If more than one material is listed, selection from materials listed is Contractor's option.
- C. Piping, Concealed:
 1. None.
 2. PVC : 20 mils (0.5 mm) thick.
- D. Piping, Exposed:
 1. PVC: 20 mils (0.5 mm) thick.

39.16 UNDERGROUND, FIELD-INSTALLED INSULATION JACKET

- A. For underground direct-buried piping applications, install underground direct-buried jacket over insulation material.

END OF SECTION

SECTION 221116 - DOMESTIC WATER PIPING

PART 41 - GENERAL

41.1 RELATED DOCUMENTS

- A. Drawings and general provisions of the Contract, including General and Supplementary Conditions and Division 01 Specification Sections, apply to this Section.

41.2 SUMMARY

- A. Section Includes:
 - 1. Under-building slab and aboveground domestic water pipes, tubes, fittings, and specialties inside the building.
 - 2. Encasement for piping.
 - 3. Specialty valves.
 - 4. Flexible connectors.
 - 5. Water meters furnished by utility company for installation by Contractor.
 - 6. Water meters.

41.3 PERFORMANCE REQUIREMENTS

- A. Seismic Performance: Domestic water piping and support and installation shall withstand effects of earthquake motions determined according to ASCE/SEI 7

41.4 SUBMITTALS

- A. Product Data: For the following products:
 - 1. Specialty valves.
 - 2. Transition fittings.
 - 3. Dielectric fittings.
 - 4. Flexible connectors.
 - 5. Water meters.
 - 6. Backflow preventers and vacuum breakers.
 - 7. Water penetration systems.
- B. LEED Submittals:
 - 1. Product Data for Credit EQ 4.1: For solvent cements and adhesive primers, documentation including printed statement of VOC content.

2. Laboratory Test Reports for Credit EQ 4: For solvent cements and adhesive primers, documentation indicating that products comply with the testing and product requirements of the California Department of Health Services' "Standard Practice for the Testing of Volatile Organic Emissions from Various Sources Using Small-Scale Environmental Chambers."
 3. Product Data for Credit EA 5: For specified metering equipment.
- C. Water Samples: Specified in "Cleaning" Article.
- D. Coordination Drawings: For piping in equipment rooms and other congested areas, drawn to scale, on which the following items are shown and coordinated with each other, using input from Installers of the items involved:
1. Fire-suppression-water piping.
 2. Domestic water piping.
 3. Compressed air piping.
 4. HVAC hydronic piping.
- E. Field quality-control reports.

41.5 QUALITY ASSURANCE

- A. Piping materials shall bear label, stamp, or other markings of specified testing agency.
- B. Comply with NSF 14 for plastic, potable domestic water piping and components.
- C. Comply with NSF 61 for potable domestic water piping and components.

41.6 PROJECT CONDITIONS

- A. Interruption of Existing Water Service: Do not interrupt water service to facilities occupied by Owner or others unless permitted under the following conditions and then only after arranging to provide temporary water service according to requirements indicated:
 1. Notify Architect days in advance of proposed interruption of water service.
 2. Do not proceed with interruption of water service without Architect's written permission.

41.7 COORDINATION

- A. Coordinate sizes and locations of concrete bases with actual equipment provided.

PART 42 - PRODUCTS

42.1 PIPING MATERIALS

- A. Comply with requirements in "Piping Schedule" Article for applications of pipe, tube, fitting materials, and joining methods for specific services, service locations, and pipe sizes.

42.2 COPPER TUBE AND FITTINGS

- A. Hard Copper Tube: **ASTM B 88, Type L (ASTM B 88M, Type B)** water tube, drawn temper.
 - 1. Cast-Copper Solder-Joint Fittings: ASME B16.18, pressure fittings.
 - 2. Wrought-Copper Solder-Joint Fittings: ASME B16.22, wrought-copper pressure fittings.
 - 3. Bronze Flanges: ASME B16.24, Class 150, with solder-joint ends.
 - 4. Copper Unions: MSS SP-123, cast-copper-alloy, hexagonal-stock body, with ball-and-socket, metal-to-metal seating surfaces, and solder-joint or threaded ends.
- B. Soft Copper Tube: **ASTM B 88, Type K (ASTM B 88M, Type A) and ASTM B 88, Type L (ASTM B 88M, Type B)** water tube, annealed temper.
 - 1. Copper Solder-Joint Fittings: ASME B16.22, wrought-copper pressure fittings.

42.3 PIPING JOINING MATERIALS

- A. Pipe-Flange Gasket Materials: AWWA C110, rubber, flat face, **1/8 inch (3.2 mm)** thick or ASME B16.21, nonmetallic and asbestos free, unless otherwise indicated; full-face or ring type unless otherwise indicated.
- B. Metal, Pipe-Flange Bolts and Nuts: ASME B18.2.1, carbon steel unless otherwise indicated.
- C. Solder Filler Metals: ASTM B 32, lead-free alloys. Include water-flushable flux according to ASTM B 813.
- D. Brazing Filler Metals: AWS A5.8/A5.8M, BCuP Series, copper-phosphorus alloys for general-duty brazing unless otherwise indicated.

42.4 ENCASEMENT FOR PIPING

- A. Standard: ASTM A 674 or AWWA C105.
- B. Form: Sheet or Tube.
- C. Material: LLDPE film of **0.008-inch (0.20-mm)** minimum thickness.
- D. Color: Black

42.5 DIELECTRIC FITTINGS

- A. General Requirements: Assembly of copper alloy and ferrous materials with separating nonconductive insulating material. Include end connections compatible with pipes to be joined.
- B. Dielectric Unions:
 - 1. Manufacturers: Subject to compliance with requirements, provide products by one of the following:

- a. Capitol Manufacturing Company.
- b. Central Plastics Company.
- c. Hart Industries International, Inc.
- d. Jomar International Ltd.
- e. Matco-Norca, Inc.
- f. McDonald, A. Y. Mfg. Co.
- g. Watts Regulator Co.; a division of Watts Water Technologies, Inc.
- h. Wilkins; a Zurn company.

2. Description:

- a. Standard: ASSE 1079.
- b. Pressure Rating: 125 psig (860 kPa) minimum at 180 deg F (82 deg C)
- c. End Connections: Solder-joint copper alloy and threaded ferrous.

C. Dielectric Flanges:

1. Manufacturers: Subject to compliance with requirements, provide products by one of the following:

- a. Capitol Manufacturing Company.
- b. Central Plastics Company.
- c. Matco-Norca, Inc.
- d. Watts Regulator Co.; a division of Watts Water Technologies, Inc.
- e. Wilkins; a Zurn company.

2. Description:

- a. Standard: ASSE 1079.
- b. Factory-fabricated, bolted, companion-flange assembly.
- c. Pressure Rating: 125 psig (860 kPa) minimum at 180 deg F (82 deg C)
- d. End Connections: Solder-joint copper alloy and threaded ferrous; threaded solder-joint copper alloy and threaded ferrous.

D. Dielectric-Flange Insulating Kits:

1. Manufacturers: Subject to compliance with requirements, provide products by one of the following:

- a. Advance Products & Systems, Inc.
- b. Calpico, Inc.
- c. Central Plastics Company.
- d. Pipeline Seal and Insulator, Inc.

2. Description:

- a. Nonconducting materials for field assembly of companion flanges.
- b. Pressure Rating: 150 psig (1035 kPa)
- c. Gasket: Neoprene or phenolic.
- d. Bolt Sleeves: Phenolic or polyethylene.
- e. Washers: Phenolic with steel backing washers.

E. Dielectric Nipples:

1. Manufacturers: Subject to compliance with requirements, provide products by one of the following:
 - a. Elster Perfection.
 - b. Grinnell Mechanical Products.
 - c. Matco-Norca, Inc.
 - d. Precision Plumbing Products, Inc.
 - e. Victaulic Company.

2. Description:
 - a. Standard: IAPMO PS 66
 - b. Electroplated steel nipple. complying with ASTM F 1545.
 - c. Pressure Rating: 300 psig (2070 kPa) at 225 deg F (107 deg C).
 - d. End Connections: Male threaded or grooved.
 - e. Lining: Inert and noncorrosive, propylene.

42.6 FLEXIBLE CONNECTORS

- A. Manufacturers: Subject to compliance with requirements, provide products by one of the following:
 1. Flex-Hose Co., Inc.
 2. Flexicraft Industries.
 3. Flex Pression, Ltd.
 4. Flex-Weld, Inc.
 5. Hyspan Precision Products, Inc.
 6. Mercer Rubber Co.
 7. Metraflex, Inc.
 8. Proco Products, Inc.
 9. Tozen Corporation.
 10. Unaflex, Inc.
 11. Universal Metal Hose; a Hyspan company

- B. Bronze-Hose Flexible Connectors: Corrugated-bronze tubing with bronze wire-braid covering and ends brazed to inner tubing.
 1. Working-Pressure Rating: Minimum [200 psig (1380 kPa)] [250 psig (1725 kPa)].
 2. End Connections NPS 2 (DN 50) and Smaller: Threaded copper pipe or plain-end copper tube.
 3. End Connections NPS 2-1/2 (DN 65) and Larger: Flanged copper alloy.

- C. Stainless-Steel-Hose Flexible Connectors: Corrugated-stainless-steel tubing with stainless-steel wire-braid covering and ends welded to inner tubing.
 1. Working-Pressure Rating: Minimum [200 psig (1380 kPa)] [250 psig (1725 kPa)].
 2. End Connections NPS 2 (DN 50) and Smaller: Threaded steel-pipe nipple.
 3. End Connections NPS 2-1/2 (DN 65) and Larger: Flanged steel nipple.

PART 43 - EXECUTION

43.1 EARTHWORK

- A. Comply with requirements in 2018 Greenbook for excavating, trenching, and backfilling.

43.2 PIPING INSTALLATION

- A. Drawing plans, schematics, and diagrams indicate general location and arrangement of domestic water piping. Indicated locations and arrangements are used to size pipe and calculate friction loss, expansion, and other design considerations. Install piping as indicated unless deviations to layout are approved on Coordination Drawings.
- B. Install copper tubing under building slab according to CDA's "Copper Tube Handbook."
- C. Install ductile-iron piping under building slab with restrained joints according to AWWA C600 and AWWA M41.
- D. Install underground copper tube in PE encasement according to ASTM A 674 or AWWA C105.
- E. Install shutoff valve, hose-end drain valve, strainer, pressure gage, and test tee with valve, inside the building at each domestic water service entrance. Comply with requirements in Division 22 Section "Meters and Gages for Plumbing Piping" for pressure gages and Division 22 Section "Domestic Water Piping Specialties" for drain valves and strainers.
- F. Install shutoff valve immediately upstream of each dielectric fitting.
- G. Install water-pressure-reducing valves downstream from shutoff valves. Comply with requirements in Division 22 Section "Domestic Water Piping Specialties" for pressure-reducing valves.
- H. Install domestic water piping level with 0.25 percent slope downward toward drain and plumb.
- I. Rough-in domestic water piping for water-meter installation according to utility company's requirements.
- J. Install seismic restraints on piping. Comply with requirements in Division 22 Section "Vibration and Seismic Controls for Plumbing Piping and Equipment" for seismic-restraint devices.
- K. Install piping concealed from view and protected from physical contact by building occupants unless otherwise indicated and except in equipment rooms and service areas.
- L. Install piping indicated to be exposed and piping in equipment rooms and service areas at right angles or parallel to building walls. Diagonal runs are prohibited unless specifically indicated otherwise.
- M. Install piping above accessible ceilings to allow sufficient space for ceiling panel removal, and coordinate with other services occupying that space.

- N. Install piping adjacent to equipment and specialties to allow service and maintenance.
- O. Install piping to permit valve servicing.
- P. Install nipples, unions, special fittings, and valves with pressure ratings the same as or higher than system pressure rating used in applications below unless otherwise indicated.
- Q. Install piping free of sags and bends.
- R. Install fittings for changes in direction and branch connections.
- S. Install PEX piping with loop at each change of direction of more than 90 degrees.
- T. Install unions in copper tubing at final connection to each piece of equipment, machine, and specialty.
- U. Install pressure gages on suction and discharge piping from each plumbing pump and packaged booster pump. Comply with requirements in Division 22 Section "Meters and Gages for Plumbing Piping" for pressure gages.
- V. Install thermostats in hot-water circulation piping. Comply with requirements for thermostats.
- W. Install thermometers on inlet and outlet piping from each water heater. Comply with requirements in Division 22 Section "Meters and Gages for Plumbing Piping" for thermometers.
- X. Install sleeves for piping penetrations of walls, ceilings, and floors. Comply with requirements for sleeves specified in Division 22 Section "Sleeves and Sleeve Seals for Plumbing Piping."
- Y. Install sleeve seals for piping penetrations of concrete walls and slabs. Comply with requirements for sleeve seals specified in Division 22 Section "Sleeves and Sleeve Seals for Plumbing Piping."
- Z. Install escutcheons for piping penetrations of walls, ceilings, and floors. Comply with requirements for escutcheons specified in Division 22 Section "Escutcheons for Plumbing Piping."

43.3 JOINT CONSTRUCTION

- A. Ream ends of pipes and tubes and remove burrs. Bevel plain ends of steel pipe.
- B. Remove scale, slag, dirt, and debris from inside and outside of pipes, tubes, and fittings before assembly.
- C. Threaded Joints: Thread pipe with tapered pipe threads according to ASME B1.20.1. Cut threads full and clean using sharp dies. Ream threaded pipe ends to remove burrs and restore full ID. Join pipe fittings and valves as follows:
 1. Apply appropriate tape or thread compound to external pipe threads.
 2. Damaged Threads: Do not use pipe or pipe fittings with threads that are corroded or damaged.

- D. Brazed Joints: Join copper tube and fittings according to CDA's "Copper Tube Handbook," "Braze Joints" Chapter.
- E. Soldered Joints: Apply ASTM B 813, water-flushable flux to end of tube. Join copper tube and fittings according to ASTM B 828 or CDA's "Copper Tube Handbook."
- F. Flanged Joints: Select appropriate asbestos-free, nonmetallic gasket material in size, type, and thickness suitable for domestic water service. Join flanges with gasket and bolts according to ASME B31.9.
- G. Dissimilar-Material Piping Joints: Make joints using adapters compatible with materials of both piping systems.

43.4 VALVE INSTALLATION

- A. General-Duty Valves: Comply with requirements in Division 22 Section "General-Duty Valves for Plumbing Piping" for valve installations.
- B. Install shutoff valve close to water main on each branch and riser serving plumbing fixtures or equipment, on each water supply to equipment, and on each water supply to plumbing fixtures that do not have supply stops. Use ball or gate valves for piping **NPS 2 (DN 50)** and smaller. Use butterfly or gate valves for piping **NPS 2-1/2 (DN 65)** and larger.
- C. Install drain valves for equipment at base of each water riser, at low points in horizontal piping, and where required to drain water piping. Drain valves are specified in Division 22 Section "Domestic Water Piping Specialties."
 - 1. Hose-End Drain Valves: At low points in water mains, risers, and branches.
 - 2. Stop-and-Waste Drain Valves: Instead of hose-end drain valves where indicated.
- D. Install balancing valve in each hot-water circulation return branch and discharge side of each pump and circulator. Set balancing valves partly open to restrict but not stop flow. Use ball valves for piping **NPS 2 (DN 50)** and smaller and butterfly valves for piping **NPS 2-1/2 (DN 65)** and larger. Comply with requirements in Division 22 Section "Domestic Water Piping Specialties" for balancing valves.
- E. Install calibrated balancing valves in each hot-water circulation return branch and discharge side of each pump and circulator. Set calibrated balancing valves partly open to restrict but not stop flow. Comply with requirements in Division 22 Section "Domestic Water Piping Specialties" for calibrated balancing valves.

43.5 TRANSITION FITTING INSTALLATION

- A. Install transition couplings at joints of dissimilar piping.
- B. Transition Fittings in Underground Domestic Water Piping:
 - 1. **NPS 1-1/2 (DN 40)** and Smaller: Fitting-type coupling.
 - 2. **NPS 2 (DN 50)** and Larger: Sleeve-type coupling.

43.6 DIELECTRIC FITTING INSTALLATION

- A. Install dielectric fittings in piping at connections of dissimilar metal piping and tubing.
- B. Dielectric Fittings for **NPS 2 (DN 50)** and Smaller: Use dielectric unions.
- C. Dielectric Fittings for **NPS 2-1/2 to NPS 4 (DN 65 to DN 100)** Use dielectric flanges.
- D. Dielectric Fittings for **NPS 5 (DN 125)** and Larger: Use dielectric flange kits.

43.7 FLEXIBLE CONNECTOR INSTALLATION

- A. Install bronze-hose flexible connectors in copper domestic water tubing.

43.8 HANGER AND SUPPORT INSTALLATION

- A. Comply with requirements in Division 22 Section "Vibration and Seismic Controls for Plumbing Piping and Equipment" for seismic-restraint devices.
- B. Comply with requirements in Division 22 Section "Hangers and Supports for Plumbing Piping and Equipment" for pipe hanger and support products and installation.
 - 1. Vertical Piping: MSS Type 8 or 42, clamps.
 - 2. Individual, Straight, Horizontal Piping Runs:
 - a. **100 Feet (30 m)** and Less: MSS Type 1, adjustable, steel clevis hangers.
 - b. Longer Than **100 Feet (30 m)**: MSS Type 43, adjustable roller hangers.
 - c. Longer Than **100 Feet (30 m)** If Indicated: MSS Type 49, spring cushion rolls.
 - 3. Multiple, Straight, Horizontal Piping Runs **100 Feet (30 m)** or Longer: MSS Type 44, pipe rolls. Support pipe rolls on trapeze.
 - 4. Base of Vertical Piping: MSS Type 52, spring hangers.
- C. Support vertical piping and tubing at base and at each floor.
- D. Rod diameter may be reduced one size for double-rod hangers, to a minimum of **3/8 inch (10 mm)**.
- E. Install hangers for copper tubing with the following maximum horizontal spacing and minimum rod diameters:
 - 1. **NPS 3/4 (DN 20)** and Smaller: **60 inches (1500 mm)** with **3/8-inch (10-mm)** rod.
 - 2. **NPS 1 and NPS 1-1/4 (DN 25 and DN 32)**: **72 inches (1800 mm)** with **3/8-inch (10-mm)** rod.
 - 3. **NPS 1-1/2 and NPS 2 (DN 40 and DN 50)**: **96 inches (2400 mm)** with **3/8-inch (10-mm)** rod.
 - 4. **NPS 2-1/2 (DN 65)**: **108 inches (2700 mm)** with **1/2-inch (13-mm)** rod.
 - 5. **NPS 3 to NPS 5 (DN 80 to DN 125)**: **10 feet (3 m)** with **1/2-inch (13-mm)** rod.
 - 6. **NPS 6 (DN 150)**: **10 feet (3 m)** with **5/8-inch (16-mm)** rod.
 - 7. **NPS 8 (DN 200)**: **10 feet (3 m)** with **3/4-inch (19-mm)** rod.
- F. Install supports for vertical copper tubing every **10 feet (3 m)**.

- G. Support piping and tubing not listed in this article according to MSS SP-69 and manufacturer's written instructions.

43.9 CONNECTIONS

- A. Drawings indicate general arrangement of piping, fittings, and specialties.
- B. Install piping adjacent to equipment and machines to allow service and maintenance.
- C. Connect domestic water piping to exterior water-service piping. Use transition fitting to join dissimilar piping materials.
- D. Connect domestic water piping to water-service piping with shutoff valve; extend and connect to the following:
 - 1. Domestic Water Booster Pumps: Cold-water suction and discharge piping.
 - 2. Water Heaters: Cold-water inlet and hot-water outlet piping in sizes indicated, but not smaller than sizes of water heater connections.
 - 3. Plumbing Fixtures: Cold- and hot-water supply piping in sizes indicated, but not smaller than required by plumbing code. Comply with requirements in Division 22 plumbing fixture Sections for connection sizes.
 - 4. Equipment: Cold- and hot-water supply piping as indicated, but not smaller than equipment connections. Provide shutoff valve and union for each connection. Use flanges instead of unions for **NPS 2-1/2 (DN 65)** and larger.

43.10 IDENTIFICATION

- A. Identify system components. Comply with requirements in Division 22 Section "Identification for Plumbing Piping and Equipment" for identification materials and installation.
- B. Label pressure piping with system operating pressure.

43.11 FIELD QUALITY CONTROL

- A. Perform tests and inspections.
- B. Piping Inspections:
 - 1. Do not enclose, cover, or put piping into operation until it has been inspected and approved by authorities having jurisdiction.
 - 2. During installation, notify authorities having jurisdiction at least one day before inspection must be made. Perform tests specified below in presence of authorities having jurisdiction:
 - a. Roughing-in Inspection: Arrange for inspection of piping before concealing or closing-in after roughing-in and before setting fixtures.
 - b. Final Inspection: Arrange final inspection for authorities having jurisdiction to observe tests specified below and to ensure compliance with requirements.

3. Reinspection: If authorities having jurisdiction find that piping will not pass tests or inspections, make required corrections and arrange for reinspection.
4. Reports: Prepare inspection reports and have them signed by authorities having jurisdiction.

C. Piping Tests:

1. Fill domestic water piping. Check components to determine that they are not air bound and that piping is full of water.
2. Test for leaks and defects in new piping and parts of existing piping that have been altered, extended, or repaired. If testing is performed in segments, submit a separate report for each test, complete with diagram of portion of piping tested.
3. Leave new, altered, extended, or replaced domestic water piping uncovered and unconcealed until it has been tested and approved. Expose work that was covered or concealed before it was tested.
4. Cap and subject piping to static water pressure of 50 psig (345 kPa) above operating pressure, without exceeding pressure rating of piping system materials. Isolate test source and allow to stand for four hours. Leaks and loss in test pressure constitute defects that must be repaired.
5. Repair leaks and defects with new materials and retest piping or portion thereof until satisfactory results are obtained.
6. Prepare reports for tests and for corrective action required.

D. Domestic water piping will be considered defective if it does not pass tests and inspections.

E. Prepare test and inspection reports.

43.12 ADJUSTING

A. Perform the following adjustments before operation:

1. Close drain valves, hydrants, and hose bibbs.
2. Open shutoff valves to fully open position.
3. Open throttling valves to proper setting.
4. Adjust balancing valves in hot-water-circulation return piping to provide adequate flow.
 - a. Manually adjust ball-type balancing valves in hot-water-circulation return piping to provide flow of hot water in each branch.
 - b. Adjust calibrated balancing valves to flows indicated.
5. Remove plugs used during testing of piping and for temporary sealing of piping during installation.
6. Remove and clean strainer screens. Close drain valves and replace drain plugs.
7. Remove filter cartridges from housings and verify that cartridges are as specified for application where used and are clean and ready for use.
8. Check plumbing specialties and verify proper settings, adjustments, and operation.

43.13 CLEANING

A. Clean and disinfect potable and non-potable domestic water piping as follows:

1. Purge new piping and parts of existing piping that have been altered, extended, or repaired before using.
 2. Use purging and disinfecting procedures prescribed by authorities having jurisdiction; if methods are not prescribed, use procedures described in either AWWA C651 or AWWA C652 or follow procedures described below:
 - a. Flush piping system with clean, potable water until dirty water does not appear at outlets.
 - b. Fill and isolate system according to either of the following:
 - 1) Fill system or part thereof with water/chlorine solution with at least **50 ppm (50 mg/L)** of chlorine. Isolate with valves and allow to stand for 24 hours.
 - 2) Fill system or part thereof with water/chlorine solution with at least **200 ppm (200 mg/L)** of chlorine. Isolate and allow to stand for three hours.
 - c. Flush system with clean, potable water until no chlorine is in water coming from system after the standing time.
 - d. Submit water samples in sterile bottles to authorities having jurisdiction. Repeat procedures if biological examination shows contamination.
- B. Clean non-potable domestic water piping as follows:
1. Purge new piping and parts of existing piping that have been altered, extended, or repaired before using.
 2. Use purging procedures prescribed by authorities having jurisdiction or; if methods are not prescribed, follow procedures described below:
 - a. Flush piping system with clean, potable water until dirty water does not appear at outlets.
 - b. Submit water samples in sterile bottles to authorities having jurisdiction. Repeat procedures if biological examination shows contamination.
- C. Prepare and submit reports of purging and disinfecting activities.
- D. Clean interior of domestic water piping system. Remove dirt and debris as work progresses.

43.14 PIPING SCHEDULE

- A. Transition and special fittings with pressure ratings at least equal to piping rating may be used in applications below unless otherwise indicated.
- B. Flanges and unions may be used for aboveground piping joints unless otherwise indicated.
- C. Fitting Option: Extruded-tee connections and brazed joints may be used on aboveground copper tubing.
- D. Aboveground domestic water piping, **NPS 2 (DN 50)** and smaller, shall be the following:
 1. Hard copper tube, **ASTM B 88, Type L (ASTM B 88M, Type B)** cast or wrought copper solder-joint fittings; and soldered joints.

- E. Aboveground domestic water piping, **NPS 2-1/2 to NPS 4 (DN 65 to DN 100)** shall be the following:
 - 1. Hard copper tube, **ASTM B 88, Type L (ASTM B 88M, Type B)** cast or wrought copper solder-joint fittings; and soldered joints.
 - 2. Hard copper tube, **ASTM B 88, Type L (ASTM B 88M, Type B)**
- F. Aboveground domestic water piping, **NPS 5 to NPS 8 (DN 125 to DN 200)** shall be the following:
 - 1. Hard copper tube, **ASTM B 88, Type L (ASTM B 88M, Type B)** cast or wrought copper solder-joint fittings; and soldered joints.

43.15 VALVE SCHEDULE

- A. Drawings indicate valve types to be used. Where specific valve types are not indicated, the following requirements apply:
 - 1. Shutoff Duty: Use ball or gate valves for piping **NPS 2 (DN 50)** and smaller. Use butterfly, ball, or gate valves with flanged ends for piping **NPS 2-1/2 (DN 65)** and larger.
 - 2. Throttling Duty: Use ball or globe valves for piping **NPS 2 (DN 50)** and smaller. Use butterfly or ball valves with flanged ends for piping **NPS 2-1/2 (DN 65)** and larger.
 - 3. Hot-Water Circulation Piping, Balancing Duty: Calibrated balancing valves.
 - 4. Drain Duty: Hose-end drain valves.
- B. Use check valves to maintain correct direction of domestic water flow to and from equipment.

END OF SECTION

SECTION 221119 – DOMESTIC WATER PIPING SPECIALTIES

PART 45 - GENERAL

45.1 RELATED DOCUMENTS

- A. Drawings and general provisions of the Contract, including General and Supplementary Conditions and Division 01 Specification Sections, apply to this Section.

45.2 SUMMARY

- A. This Section includes the following domestic water piping specialties:

1. Vacuum breakers.
2. Backflow preventers.
3. Water pressure-reducing valves.
4. Balancing valves.
5. Temperature-actuated water mixing valves.
6. Strainers.
7. Outlet boxes.
8. Hose bibbs.
9. Wall hydrants.
10. Drain valves.
11. Water hammer arresters.
12. Air vents.
13. Trap-seal primer valves.
14. Trap-seal primer systems.

- B. Related Sections include the following:

1. Division 22 Section "Meters and Gages for Plumbing Piping" for thermometers, pressure gages, and flow meters in domestic water piping.
2. Division 22 Section "Domestic Water Piping" for water meters.

45.3 PERFORMANCE REQUIREMENTS

- A. Minimum Working Pressure for Domestic Water Piping Specialties: **125 psig (860 kPa)** unless otherwise indicated.

45.4 SUBMITTALS

- A. Product Data: For each type of product indicated.
- B. Shop Drawings: Diagram power, signal, and control wiring.
- C. Field quality-control test reports.
- D. Operation and Maintenance Data: For domestic water piping specialties to include in emergency, operation, and maintenance manuals.

45.5 QUALITY ASSURANCE

- A. Electrical Components, Devices, and Accessories: Listed and labeled as defined in NFPA 70, Article 100, by a testing agency acceptable to authorities having jurisdiction, and marked for intended use.
- B. NSF Compliance:
 - 1. Comply with NSF 14, "Plastics Piping Components and Related Materials," for plastic domestic water piping components.
 - 2. Comply with NSF 61, "Drinking Water System Components - Health Effects; Sections 1 through 9."

PART 46 - PRODUCTS

46.1 VACUUM BREAKERS

- A. Pipe-Applied, Atmospheric-Type Vacuum Breakers :
 - 1. Manufacturers: Subject to compliance with requirements, provide products by one of the following:
 - a. Ames Co.
 - b. Cash Acme.
 - c. Conbraco Industries, Inc.
 - d. FEBCO; SPX Valves & Controls.
 - e. Rain Bird Corporation.
 - f. Toro Company (The); Irrigation Div.
 - g. Watts Industries, Inc.; Water Products Div.
 - h. Zurn Plumbing Products Group; Wilkins Div.
 - 2. Standard: ASSE 1001.
 - 3. Size: **NPS 1/4 to NPS 3 (DN 8 to DN 80)**, as required to match connected piping.
 - 4. Body: Bronze.
 - 5. Inlet and Outlet Connections: Threaded.
 - 6. Finish: Chrome plated.

46.2 BACKFLOW PREVENTERS

A. Intermediate Atmospheric-Vent Backflow Preventers

1. Manufacturers: Subject to compliance with requirements, provide products by one of the following:
 - a. Cash Acme.
 - b. Conbraco Industries, Inc.
 - c. FEBCO; SPX Valves & Controls.
 - d. Honeywell Water Controls.
 - e. Legend Valve.
 - f. Watts Industries, Inc.; Water Products Div.
 - g. Zurn Plumbing Products Group; Wilkins Div.
2. Standard: ASSE 1012.
3. Operation: Continuous-pressure applications.
4. Size: See Schedule Sheet P0.2
5. Body: Bronze.
6. End Connections: Union, solder joint.
7. Finish: Chrome plated

B. Reduced-Pressure-Principle Backflow Preventers

1. Manufacturers: Subject to compliance with requirements, provide products by one of the following:
 - a. Bradley Corporation.
 - b. Watts Industries, Inc.; Water Products Div.
 - c. Zurn Plumbing Products Group; Wilkins Div.
2. Standard: ASSE 1070.
3. Operation: Continuous-pressure applications.
4. Pressure Loss: **12 psig (83 kPa)** maximum, through middle 1/3 of flow range.
5. Size: See Schedule Sheet P0.2
6. Design Flow Rate: See Schedule Sheet P0.2
7. Selected Unit Flow Range Limits: See Schedule Sheet P0.2
8. Pressure Loss at Design Flow Rate: see Schedule Sheet P0.2 for sizes **NPS 2 (DN 50)** and smaller; for **NPS 2-1/2 (DN 65)** and larger.
9. Body: Bronze for **NPS 2 (DN 50)** and smaller; stainless steel for **NPS 2-1/2 (DN 65)** and larger.
10. End Connections: Threaded for **NPS 2 (DN 50)** and smaller; flanged for **NPS 2-1/2 (DN 65)** and larger.
11. Configuration: Designed for horizontal, straight through flow.
12. Accessories:
 - a. Valves: Ball type with threaded ends on inlet and outlet of **NPS 2 (DN 50)** and smaller; outside screw and yoke gate-type with flanged ends on inlet and outlet of **NPS 2-1/2 (DN 65)** and larger.
 - b. Air-Gap Fitting: ASME A112.1.2, matching backflow-preventer connection.

C. Hose-Connection Backflow Preventers :

1. Manufacturers: Subject to compliance with requirements, provide products by one of the following:
 - a. Conbraco Industries, Inc.
 - b. Watts Industries, Inc.; Water Products Div.
 - c. Woodford Manufacturing Company.
2. Standard: ASSE 1052.
3. Operation: Up to 10-foot head of water (30-kPa) back pressure.
4. Inlet Size: NPS 1/2 or NPS 3/4 (DN 15 or DN 20).
5. Outlet Size: Garden-hose thread complying with ASME B1.20.7.
6. Capacity: At least 3-gpm (0.19-L/s) flow.

46.3 WATER PRESSURE-REDUCING VALVES

A. Water Regulators :

1. Manufacturers: Subject to compliance with requirements, provide products by one of the following:
 - a. Cash Acme.
 - b. Conbraco Industries, Inc.
 - c. Honeywell Water Controls.
 - d. Watts Industries, Inc.; Water Products Div.
 - e. Zurn Plumbing Products Group; Wilkins Div.
2. Standard: ASSE 1003.
3. Pressure Rating: Initial working pressure of 150 psig (1035 kPa).
4. Size: See Schedule Sheet P0.2
5. Design Flow Rate: See Schedule Sheet P0.2
6. Design Inlet Pressure: See Schedule Sheet P0.2
7. Design Outlet Pressure Setting: See Schedule Sheet P0.2
8. Body: Bronze for NPS 2 (DN 50) and smaller; cast iron with interior lining complying with AWWA C550 or that is FDA approved for NPS 2-1/2 and NPS 3 (DN 65 and DN 80).
9. Valves for Booster Heater Water Supply: Include integral bypass.
10. End Connections: Threaded for NPS 2 (DN 50) and smaller; flanged for NPS 2-1/2 and NPS 3 (DN 65 and DN 80).

46.4 BALANCING VALVES

A. Copper-Alloy Calibrated Balancing Valves:

1. Manufacturers: Subject to compliance with requirements, provide products by one of the following:
 - a. Armstrong International, Inc.
 - b. Flo Fab Inc.
 - c. ITT Industries; Bell & Gossett Div.
 - d. NIBCO INC.
 - e. TAC Americas.

- f. Taco, Inc.
 - g. Watts Industries, Inc.; Water Products Div.
2. Type: Ball or Y-pattern globe valve with two readout ports and memory setting indicator.
 3. Body: Brass or bronze,
 4. Size: Same as connected piping, but not larger than **NPS 2 (DN 50)**.
 5. Accessories: Meter hoses, fittings, valves, differential pressure meter, and carrying case.

46.5 TEMPERATURE-ACTUATED WATER MIXING VALVES

A. Water-Temperature Limiting Devices:

1. Manufacturers: Subject to compliance with requirements, provide products by one of the following:
 - a. Leonard Valve Company.
 - b. Powers; a Watts Industries Co.
 - c. Symmons Industries, Inc.
 - d. Bradley Corporation.
2. Standard: ASSE 1017.
3. Pressure Rating: **125 psig (860 kPa)**.
4. Type: Thermostatically controlled water mixing valve.
5. Material: Bronze body with corrosion-resistant interior components.
6. Connections: Threaded inlets and outlet.
7. Accessories: Check stops on hot- and cold-water supplies, and adjustable, temperature-control handle.
8. Tempered-Water Setting: 120° F.
9. Tempered-Water Design Flow Rate: 15 gpm.
10. Valve Finish: Chrome plated

B. Primary, Thermostatic, Water Mixing Valves

1. Manufacturers: Subject to compliance with requirements, provide products by one of the following:
 - a. Armstrong International, Inc.
 - b. Lawler Manufacturing Company, Inc.
 - c. Leonard Valve Company.
 - d. Powers; a Watts Industries Co.
 - e. Symmons Industries, Inc.
2. Standard: ASSE 1017.
3. Pressure Rating: **125 psig (860 kPa)**.
4. Type: Exposed-mounting thermostatically controlled water mixing valve.
5. Material: Bronze body with corrosion-resistant interior components.
6. Connections: Threaded inlets and outlet.
7. Accessories: Manual temperature control, check stops on hot- and cold-water supplies, and adjustable, temperature-control handle.
8. Valve Pressure Rating: **125 psig (860 kPa)** minimum, unless otherwise indicated.

9. Tempered-Water Setting: See Schedule Sheet P0.2.
10. Tempered-Water Design Flow Rate: See Schedule Sheet P0.2.
11. Selected Valve Flow Rate at See Schedule Sheet P0.2.
12. Pressure Drop at Design Flow Rate: See Schedule Sheet P0.2.
13. Valve Finish: Chrome plated
14. Piping Finish: Chrome plated
15. Cabinet: Factory-fabricated, stainless steel, for surface mounting and with hinged, stainless-steel door.

C. Individual-Fixture, Water Tempering Valves

1. Manufacturers: Subject to compliance with requirements, provide products by one of the following:
 - a. Cash Acme.
 - b. Conbraco Industries, Inc.
 - c. Honeywell Water Controls.
 - d. Lawler Manufacturing Company, Inc.
 - e. Leonard Valve Company.
 - f. Powers; a Watts Industries Co.
 - g. Watts Industries, Inc.; Water Products Div.
 - h. Zurn Plumbing Products Group; Wilkins Div.
2. Standard: ASSE 1016, thermostatically controlled water tempering valve.
3. Pressure Rating: 125 psig (860 kPa) minimum, unless otherwise indicated.
4. Body: Bronze body with corrosion-resistant interior components.
5. Temperature Control: Adjustable.
6. Inlets and Outlet: Threaded.
7. Finish: Rough or chrome-plated bronze.
8. Tempered-Water Setting: 105
9. Tempered-Water Design Flow Rate: 0.35 Minimum.

46.6 STRAINERS FOR DOMESTIC WATER PIPING

A. Y-Pattern Strainers:

1. Pressure Rating: 125 psig (860 kPa) minimum, unless otherwise indicated.
2. Body: Bronze for NPS 2 (DN 50) and smaller; cast iron with interior lining complying with AWWA C550 or FDA-approved, epoxy coating and for NPS 2-1/2 (DN 65) and larger.
3. End Connections: Threaded for NPS 2 (DN 50) and smaller; flanged for NPS 2-1/2 (DN 65) and larger.
4. Screen: Stainless steel with round perforations, unless otherwise indicated.
5. Perforation Size:
 - a. Strainers NPS 2 (DN 50) and Smaller: 0.020 inch (0.51 mm)
 - b. Strainers NPS 2-1/2 to NPS 4 (DN 65 to DN 100): 0.045 inch (1.14 mm)
 - c. Strainers NPS 5 (DN 125) and Larger: 0.10 inch (2.54 mm)
6. Drain: Pipe plug or Factory-installed, hose-end drain valve.

46.7 OUTLET BOXES

A. Clothes Washer Outlet Boxes:

1. Available Manufacturers: Subject to compliance with requirements, manufacturers offering products that may be incorporated into the Work include, but are not limited to, the following:
2. Manufacturers: Subject to compliance with requirements, provide products by one of the following:
 - a. Acorn Engineering Company.
 - b. Guy Gray Manufacturing Co., Inc.
 - c. IPS Corporation.
 - d. LSP Products Group, Inc.
 - e. Oatey.
 - f. Plastic Oddities; a division of Diverse Corporate Technologies.
 - g. Symmons Industries, Inc.
 - h. Watts Industries, Inc.; Water Products Div.
 - i. Whitehall Manufacturing; a div. of Acorn Engineering Company.
 - j. Zurn Plumbing Products Group; Light Commercial Operation.
3. Mounting: Recessed.
4. Material and Finish: Enameled-steel or epoxy-painted-steel or plastic box and faceplate.
5. Faucet: Combination, valved fitting or separate hot- and cold-water, valved fittings complying with ASME A112.18.1. Include garden-hose thread complying with ASME B1.20.7 on outlets.
6. Supply Shutoff Fittings: **NPS 1/2 (DN 15)** gate, globe, or ball valves and **NPS 1/2 (DN 15)** copper, water tubing.
7. Drain: **NPS 2 (DN 50)** standpipe and P-trap for direct waste connection to drainage piping.
8. Inlet Hoses: Two **60-inch- (1500-mm-)** long, rubber household clothes washer inlet hoses with female, garden-hose-thread couplings. Include rubber washers.
9. Drain Hose: One **48-inch- (1200-mm-)** long, rubber household clothes washer drain hose with hooked end.

B. Icemaker Outlet Boxes :

1. Manufacturers: Subject to compliance with requirements, provide products by one of the following:
 - a. Acorn Engineering Company.
 - b. IPS Corporation.
 - c. LSP Products Group, Inc.
 - d. Oatey.
 - e. Plastic Oddities; a division of Diverse Corporate Technologies.
2. Mounting: Recessed.
3. Material and Finish: Enameled-steel or epoxy-painted-steel or plastic box and faceplate.
4. Faucet: Valved fitting complying with ASME A112.18.1. Include **NPS 1/2 (DN 15)** or smaller copper tube outlet.

5. Supply Shutoff Fitting: **NPS 1/2 (DN 15)** gate, globe, or ball valve and **NPS 1/2 (DN 15)** copper, water tubing.

46.8 HOSE BIBBS

A. Hose Bibbs :

1. Standard: ASME A112.18.1 for sediment faucets.
2. Body Material: Bronze.
3. Seat: Bronze, replaceable.
4. Supply Connections: **NPS 1/2 or NPS 3/4 (DN 15 or DN 20)** threaded or solder-joint inlet.
5. Outlet Connection: Garden-hose thread complying with ASME B1.20.7.
6. Pressure Rating: **125 psig (860 kPa)**.
7. Vacuum Breaker: Integral nonremovable, drainable, hose-connection vacuum breaker complying with ASSE 1011.
8. Finish for Equipment Rooms: Rough bronze, or chrome or nickel plated.
9. Finish for Service Areas: Rough bronze.
10. Finish for Finished Rooms: Chrome or nickel plated.
11. Operation for Equipment Rooms: Wheel handle or operating key.
12. Operation for Service Areas: Wheel handle
13. Operation for Finished Rooms: Wheel handle
14. Include operating key with each operating-key hose bibb.
15. Include integral wall flange with each chrome- or nickel-plated hose bibb.

46.9 WALL HYDRANTS

A. Moderate-Climate Wall Hydrants:

1. Available Manufacturers: Subject to compliance with requirements, manufacturers offering products that may be incorporated into the Work include, but are not limited to, the following:
2. Manufacturers: Subject to compliance with requirements, provide products by one of the following:
 - a. Josam Company.
 - b. MIFAB, Inc.
 - c. Prier Products, Inc.
 - d. Smith, Jay R. Mfg. Co.; Division of Smith Industries, Inc.
 - e. Tyler Pipe; Wade Div.
 - f. Watts Drainage Products Inc.
 - g. Woodford Manufacturing Company.
 - h. Zurn Plumbing Products Group; Light Commercial Operation.
 - i. Zurn Plumbing Products Group; Specification Drainage Operation.
3. Standard: ASME A112.21.3M for concealed-outlet, self-draining wall hydrants.
4. Pressure Rating: **125 psig (860 kPa)**.
5. Operation: Loose key.
6. Inlet: **NPS 3/4 or NPS 1 (DN 20 or DN 25)**.
7. Outlet: Concealed, with integral vacuum breaker or nonremovable hose-connection vacuum breaker complying with ASSE 1011 or backflow preventer complying with ASSE 1052; and garden-hose thread complying with ASME B1.20.7.
8. Box: Deep, flush mounting with cover.

9. Box and Cover Finish: Polished nickel bronze.
10. Outlet: Exposed, with integral vacuum breaker or nonremovable hose-connection vacuum breaker complying with ASSE 1011] or backflow preventer complying with ASSE 1052; and garden-hose thread complying with ASME B1.20.7.
11. Nozzle and Wall-Plate Finish: Polished nickel bronze
12. Operating Keys(s): One with each wall hydrant.

46.10 DRAIN VALVES

A. Ball-Valve-Type, Hose-End Drain Valves:

1. Standard: MSS SP-110 for standard-port, two-piece ball valves.
2. Pressure Rating: 400-psig (2760-kPa) minimum CWP.
3. Size: NPS 3/4 (DN 20).
4. Body: Copper alloy.
5. Ball: Chrome-plated brass.
6. Seats and Seals: Replaceable.
7. Handle: Vinyl-covered steel.
8. Inlet: Threaded or solder joint.
9. Outlet: Threaded, short nipple with garden-hose thread complying with ASME B1.20.7 and cap with brass chain.

B. Gate-Valve-Type, Hose-End Drain Valves:

1. Standard: MSS SP-80 for gate valves.
2. Pressure Rating: Class 125.
3. Size: NPS 3/4 (DN 20).
4. Body: ASTM B 62 bronze.
5. Inlet: NPS 3/4 (DN 20) threaded or solder joint.
6. Outlet: Garden-hose thread complying with ASME B1.20.7 and cap with brass chain.

C. Stop-and-Waste Drain Valves

1. Standard: MSS SP-110 for ball valves or MSS SP-80 for gate valves.
2. Pressure Rating: 200-psig (1380-kPa) minimum CWP or Class 125.
3. Size: NPS 3/4 (DN 20).
4. Body: Copper alloy or ASTM B 62 bronze.
5. Drain: NPS 1/8 (DN 6) side outlet with cap.

46.11 WATER HAMMER ARRESTERS

A. Water Hammer Arresters:

1. Manufacturers: Subject to compliance with requirements, provide products by one of the following:
 - a. AMTROL, Inc.
 - b. Josam Company.
 - c. MIFAB, Inc.
 - d. PPP Inc.
 - e. Sioux Chief Manufacturing Company, Inc.
 - f. Smith, Jay R. Mfg. Co.; Division of Smith Industries, Inc.

- g. Tyler Pipe; Wade Div.
 - h. Watts Drainage Products Inc.
 - i. Zurn Plumbing Products Group; Specification Drainage Operation.
2. Standard: ASSE 1010 or PDI-WH 201.
 3. Type: Metal bellows
 4. Size: ASSE 1010, Sizes AA and A through F or PDI-WH 201, Sizes A through F.

46.12 TRAP-SEAL PRIMER VALVES

A. Supply-Type, Trap-Seal Primer Valves:

1. Manufacturers: Subject to compliance with requirements, provide products by one of the following:
 - a. MIFAB, Inc.
 - b. PPP Inc.
 - c. Sioux Chief Manufacturing Company, Inc.
 - d. Smith, Jay R. Mfg. Co.; Division of Smith Industries, Inc.
 - e. Watts Industries, Inc.; Water Products Div.
2. Standard: ASSE 1018.
3. Pressure Rating: 125 psig (860 kPa) minimum.
4. Body: Bronze
5. Inlet and Outlet Connections: NPS 1/2 (DN 15) threaded, union, or solder joint.
6. Gravity Drain Outlet Connection: NPS 1/2 (DN 15) threaded or solder joint.
7. Finish: Chrome plated, or rough bronze for units used with pipe or tube that is not chrome finished.

46.13 TRAP-SEAL PRIMER SYSTEMS

A. Trap-Seal Primer Systems :

1. Available Manufacturers: Subject to compliance with requirements, manufacturers offering products that may be incorporated into the Work include, but are not limited to, the following:
 - a. PPP Inc.
2. Standard: ASSE 1044,
3. Piping: NPS 3/4, ASTM B 88, Type L (DN 20, ASTM B 88M, Type B); copper, water tubing.
4. Cabinet: Recessed or surface mounting steel box with stainless-steel cover.
5. Electric Controls: 24-hour timer, solenoid valve, and manual switch for 120-V ac power.
6. Vacuum Breaker: ASSE 1001.
7. Number Outlets: Four
8. Size Outlets: NPS 1/2 (DN 15).

PART 47 - EXECUTION

47.1 INSTALLATION

- A. Refer to Section 220000 "General Plumbing Requirements" for piping joining materials, joint construction, and basic installation requirements.
- B. Install backflow preventers in each water supply to mechanical equipment and systems and to other equipment and water systems that may be sources of contamination. Comply with authorities having jurisdiction.
 - 1. Locate backflow preventers in same room as connected equipment or system.
 - 2. Install drain for backflow preventers with atmospheric-vent drain connection with air-gap fitting, fixed air-gap fitting, or equivalent positive pipe separation of at least two pipe diameters in drain piping and pipe to floor drain. Locate air-gap device attached to or under backflow preventer. Simple air breaks are not acceptable for this application.
 - 3. Do not install bypass piping around backflow preventers.
- C. Install water regulators with inlet and outlet shutoff valves. Install pressure gages on inlet and outlet.
- D. Install water control valves with inlet and outlet shutoff valves. Install pressure gages on inlet and outlet.
- E. Install balancing valves in locations where they can easily be adjusted.
- F. Install temperature-actuated water mixing valves with check stops or shutoff valves on inlets and with shutoff valve on outlet.
 - 1. Install thermometers and water regulators if specified.
 - 2. Install cabinet-type units recessed in or surface mounted on wall as specified.
- G. Install Y-pattern strainers for water on supply side of each control valve, water pressure-reducing valve, solenoid valve, and pump.
- H. Install outlet boxes recessed in wall. Install 2-by-4-inch (38-by-89-mm) fire-retardant-treated-wood blocking wall reinforcement between studs. Fire-retardant-treated-wood blocking is specified in Division 06 Section "Rough Carpentry."
- I. Install hose stations with check stops or shutoff valves on inlets and with thermometer on outlet.
 - 1. Install shutoff valve on outlet if specified.
 - 2. Install cabinet-type units recessed in or surface mounted on wall as specified. Install 2-by-4-inch (38-by-89-mm) fire-retardant-treated-wood blocking wall reinforcement between studs. Fire-retardant-treated-wood blocking is specified in Division 06 Section "Rough Carpentry."
- J. Install freeze-resistant yard hydrants with riser pipe set in concrete or pavement. Do not encase canister in concrete.
- K. Install water hammer arresters in water piping according to PDI-WH 201.

- L. Install air vents at high points of water piping.
- M. Install supply-type, trap-seal primer valves with outlet piping pitched down toward drain trap a minimum of 1 percent, and connect to floor-drain body, trap, or inlet fitting. Adjust valve for proper flow.
- N. Install drainage-type, trap-seal primer valves as lavatory trap with outlet piping pitched down toward drain trap a minimum of 1 percent, and connect to floor-drain body, trap, or inlet fitting.
- O. Install trap-seal primer systems with outlet piping pitched down toward drain trap a minimum of 1 percent, and connect to floor-drain body, trap, or inlet fitting. Adjust system for proper flow.

47.2 CONNECTIONS

- A. Piping installation requirements are specified in other Division 22 Sections. Drawings indicate general arrangement of piping and specialties.
- B. Ground equipment according to Division 26 Section "Grounding and Bonding for Electrical Systems."
- C. Connect wiring according to Division 26 Section "Low-Voltage Electrical Power Conductors and Cables."

47.3 LABELING AND IDENTIFYING

- A. Equipment Nameplates and Signs: Install engraved plastic-laminate equipment nameplate or sign on or near each of the following:
 1. Pressure vacuum breakers.
 2. Reduced-pressure-principle backflow preventers.
 3. Water pressure-reducing valves.
 4. Calibrated balancing valves.
 5. Primary, thermostatic, water mixing valves.
 6. Manifold, thermostatic, water-mixing-valve assemblies.
 7. Primary water tempering valves.
 8. Outlet boxes.
 9. Supply-type, trap-seal primer valves.
 10. Trap-seal primer systems.
- B. Distinguish among multiple units, inform operator of operational requirements, indicate safety and emergency precautions, and warn of hazards and improper operations, in addition to identifying unit. Nameplates and signs are specified in Division 22 Section "Identification for Plumbing Piping and Equipment."

47.4 FIELD QUALITY CONTROL

- A. Perform the following tests and prepare test reports:

1. Test each reduced-pressure-principle backflow preventer according to authorities having jurisdiction and the device's reference standard.
- B. Remove and replace malfunctioning domestic water piping specialties and retest as specified above.

47.5 ADJUSTING

- A. Set field-adjustable pressure set points of water pressure-reducing valves.
- B. Set field-adjustable flow set points of balancing valves.
- C. Set field-adjustable temperature set points of temperature-actuated water mixing valves.

END OF SECTION

SECTION 221316 - SANITARY WASTE AND VENT PIPING

PART 49 - GENERAL

49.1 RELATED DOCUMENTS

- A. Drawings and general provisions of the Contract, including General and Supplementary Conditions and Division 01 Specification Sections, apply to this Section.

49.2 SUMMARY

- A. Section Includes:

1. Pipe, tube, and fittings.
2. Specialty pipe fittings.
3. Encasement for underground metal piping.

- B. Related Sections:

1. 2018 Greenbook for sanitary sewerage piping and structures outside the building.

49.3 PERFORMANCE REQUIREMENTS

- A. Components and installation shall be capable of withstanding the following minimum working pressure unless otherwise indicated:

1. Soil, Waste, and Vent Piping: 10-foot head of water.
2. Waste, Force-Main Piping: 50 psig.

- B. Seismic Performance: Soil, waste, and vent piping and support and installation shall withstand the effects of earthquake motions determined according to ASCE/SEI 7

49.4 SUBMITTALS

- A. Product Data: For each type of product indicated.

- B. LEED Submittals:

1. Product Data for Credit EQ 4.1: For solvent cements and adhesive primers, documentation including printed statement of VOC content.
2. Laboratory Test Reports for Credit EQ 4: For solvent cements and adhesive primers, documentation indicating that products comply with the testing and product requirements of the California Department of Health Services' "Standard Practice for the Testing of Volatile Organic Emissions from Various Sources Using Small-Scale Environmental Chambers."

- C. Shop Drawings: For sovent drainage system. Include plans, elevations, sections, and details.
- D. Seismic Qualification Certificates: For waste and vent piping, accessories, and components, from manufacturer.
 - 1. Basis for Certification: Indicate whether withstand certification is based on actual test of assembled components or on calculation.
 - 2. Detailed description of piping anchorage devices on which the certification is based and their installation requirements.
- E. Field quality-control reports.

49.5 QUALITY ASSURANCE

- A. Piping materials shall bear label, stamp, or other markings of specified testing agency.
- B. Comply with NSF/ANSI 14, "Plastics Piping Systems Components and Related Materials," for plastic piping components. Include marking with "NSF-dwv" for plastic drain, waste, and vent piping and "NSF-sewer" for plastic sewer piping.
- C. All cast iron soil pipe and fittings shall be marked with the collective trademark of the Cast Iron Soil Pipe Institute (CISPI) and be listed by NSF International.
- D. All couplings for hubless cast iron soil pipe and fittings shall meet the requirements of CISPI 310 and be certified by NSF International.

49.6 PROJECT CONDITIONS

- A. Interruption of Existing Sanitary Waste Service: Do not interrupt service to facilities occupied by Owner or others unless permitted under the following conditions and then only after arranging to provide temporary service according to requirements indicated:
 - 1. Notify Architect no fewer than two days in advance of proposed interruption of sanitary waste service.
 - 2. Do not proceed with interruption of sanitary waste service without Architect's written permission.

PART 50 - PRODUCTS

50.1 PIPING MATERIALS

- A. Comply with requirements in "Piping Schedule" Article for applications of pipe, tube, fitting materials, and joining methods for specific services, service locations, and pipe sizes.

50.2 HUB-AND-SPIGOT, CAST-IRON SOIL PIPE AND FITTINGS

- A. Pipe and Fittings: ASTM A 74, Service and Extra Heavy class(es).

- B. Gaskets: ASTM C 564, rubber.
- C. Calking Materials: ASTM B 29, pure lead and oakum or hemp fiber.

50.3 HUBLESS, CAST-IRON SOIL PIPE AND FITTINGS

- A. Pipe and Fittings: ASTM A 888 or CISPI 301.
- B. CISPI, Hubless-Piping Couplings:
 1. Manufacturers: Subject to compliance with requirements, provide products by one of the following:
 - a. ANACO-Husky.
 - b. Dallas Specialty & Mfg. Co.
 - c. Fernco Inc.
 - d. Matco-Norca, Inc.
 - e. MIFAB, Inc.
 - f. Mission Rubber Company; a division of MCP Industries, Inc.
 - g. Stant.
 - h. Tyler Pipe.
 2. Standards: ASTM C 1277 and CISPI 310.
 3. Description: Stainless-steel corrugated shield with stainless-steel bands and tightening devices; and ASTM C 564, rubber sleeve with integral, center pipe stop.

- C. Heavy-Duty, Hubless-Piping Couplings:
 1. Manufacturers: Subject to compliance with requirements, provide products by one of the following:
 - a. ANACO-Husky.
 - b. Clamp-All Corp.
 - c. Dallas Specialty & Mfg. Co.
 - d. MIFAB, Inc.
 - e. Mission Rubber Company; a division of MCP Industries, Inc.
 - f. Stant.
 - g. Tyler Pipe.
 2. Standards: ASTM C 1277 and ASTM C 1540.
 3. Description: Stainless-steel shield with stainless-steel bands and tightening devices; and ASTM C 564, rubber sleeve with integral, center pipe stop.

50.4 COPPER TUBE AND FITTINGS

- A. Copper DWV Tube: ASTM B 306, drainage tube, drawn temper.
- B. Copper Drainage Fittings: ASME B16.23, cast copper or ASME B16.29, wrought copper, solder-joint fittings.
- C. Hard Copper Tube: **ASTM B 88, Type L and Type M** (ASTM B 88M, Type B and Type C), water tube, drawn temper.

- D. Soft Copper Tube: **ASTM B 88, Type L** (**ASTM B 88M, Type B**), water tube, annealed temper.
- E. Copper Pressure Fittings:
 - 1. Copper Fittings: ASME B16.18, cast-copper-alloy or ASME B16.22, wrought-copper, solder-joint fittings. Furnish wrought-copper fittings if indicated.
 - 2. Copper Unions: MSS SP-123, copper-alloy, hexagonal-stock body with ball-and-socket, metal-to-metal seating surfaces, and solder-joint or threaded ends.
- F. Copper Flanges: ASME B16.24, Class 150, cast copper with solder-joint end.
 - 1. Flange Gasket Materials: ASME B16.21, full-face, flat, nonmetallic, asbestos-free, **1/8-inch** maximum thickness unless thickness or specific material is indicated.
 - 2. Flange Bolts and Nuts: ASME B18.2.1, carbon steel unless otherwise indicated.
- G. Solder: ASTM B 32, lead free with ASTM B 813, water-flushable flux.

50.5 PVC PIPE AND FITTINGS

- A. Solid-Wall PVC Pipe: ASTM D 2665, drain, waste, and vent.
- B. Cellular-Core PVC Pipe: ASTM F 891, Schedule 40.
- C. PVC Socket Fittings: ASTM D 2665, made to ASTM D 3311, drain, waste, and vent patterns and to fit Schedule 40 pipe.
- D. Adhesive Primer: ASTM F 656.
 - 1. Adhesive primer shall have a VOC content of 550 g/L or less when calculated according to 40 CFR 59, Subpart D (EPA Method 24).
 - 2. Adhesive primer shall comply with the testing and product requirements of the California Department of Health Services' "Standard Practice for the Testing of Volatile Organic Emissions from Various Sources Using Small-Scale Environmental Chambers."
- E. Solvent Cement: ASTM D 2564.
 - 1. PVC solvent cement shall have a VOC content of 510 g/L or less when calculated according to 40 CFR 59, Subpart D (EPA Method 24).
 - 2. Solvent cement shall comply with the testing and product requirements of the California Department of Health Services' "Standard Practice for the Testing of Volatile Organic Emissions from Various Sources Using Small-Scale Environmental Chambers"

50.6 SPECIALTY PIPE FITTINGS

- A. Transition Couplings:
 - 1. General Requirements: Fitting or device for joining piping with small differences in OD's or of different materials. Include end connections same size as and compatible with pipes to be joined.

2. Fitting-Type Transition Couplings: Manufactured piping coupling or specified piping system fitting.
3. Shielded, Nonpressure Transition Couplings:
 - a. Manufacturers: Subject to compliance with requirements, provide products by one of the following:
 - 1) Cascade Waterworks Mfg. Co.
 - 2) Mission Rubber Company; a division of MCP Industries, Inc.
 - b. Standard: ASTM C 1460.
 - c. Description: Elastomeric or rubber sleeve with full-length, corrosion-resistant outer shield and corrosion-resistant-metal tension band and tightening mechanism on each end.

B. Dielectric Fittings:

1. General Requirements: Assembly of copper alloy and ferrous materials with separating nonconductive insulating material. Include end connections compatible with pipes to be joined.
2. Dielectric Unions:
 - a. Manufacturers: Subject to compliance with requirements, provide products by one of the following:
 - 1) Capitol Manufacturing Company.
 - 2) Central Plastics Company.
 - 3) Hart Industries International, Inc.
 - 4) Jomar International Ltd.
 - 5) Matco-Norca, Inc.
 - 6) McDonald, A. Y. Mfg. Co.
 - 7) Watts Regulator Co.; a division of Watts Water Technologies, Inc.
 - 8) Wilkins; a Zurn company.
 - b. Description:
 - 1) Standard: ASSE 1079.
 - 2) Pressure Rating: 125 psig minimum at 180 deg F.
 - 3) End Connections: Solder-joint copper alloy and threaded ferrous.
3. Dielectric-Flange Insulating Kits:
 - a. Manufacturers: Subject to compliance with requirements, provide products by one of the following:
 - 1) Advance Products & Systems, Inc.
 - 2) Calpico, Inc.
 - 3) Central Plastics Company.
 - 4) Pipeline Seal and Insulator, Inc.
 - b. Description:
 - 1) Nonconducting materials for field assembly of companion flanges.

- 2) Pressure Rating: 150 psig
- 3) Gasket: Neoprene or phenolic.
- 4) Bolt Sleeves: Phenolic or polyethylene.
- 5) Washers: Phenolic with steel backing washers.

4. Dielectric Nipples:

- a. Manufacturers: Subject to compliance with requirements, provide products by one of the following:

- 1) Elster Perfection.
- 2) Grinnell Mechanical Products.
- 3) Matco-Norca, Inc.
- 4) Precision Plumbing Products, Inc.
- 5) Victaulic Company.

- b. Description:

- 1) Standard: IAPMO PS 66
- 2) Electroplated steel nipple.
- 3) Pressure Rating: 300 psig at 225 deg F.
- 4) End Connections: Male threaded or grooved.
- 5) Lining: Inert and noncorrosive, propylene.

50.7 ENCASUREMENT FOR UNDERGROUND METAL PIPING

- A. Standard: ASTM A 674 or AWWA C105/A 21.5.
- B. Material: Linear low-density polyethylene film of 0.008-inch or high-density, cross-laminated polyethylene film of 0.004-inch minimum thickness.
- C. Form: Sheet or tube.
- D. Color: Black

PART 51 - EXECUTION

51.1 EARTH MOVING

- A. Comply with requirements for excavating, trenching, and backfilling specified in 2018 Greenbook Sections 300.

51.2 PIPING INSTALLATION

- A. Drawing plans, schematics, and diagrams indicate general location and arrangement of piping systems. Indicated locations and arrangements were used to size pipe and calculate friction loss, expansion, pump sizing, and other design considerations. Install piping as indicated unless deviations to layout are approved on coordination drawings.
- B. Install piping in concealed locations unless otherwise indicated and except in equipment rooms and service areas.

- C. Install piping indicated to be exposed and piping in equipment rooms and service areas at right angles or parallel to building walls. Diagonal runs are prohibited unless specifically indicated otherwise.
- D. Install piping above accessible ceilings to allow sufficient space for ceiling panel removal.
- E. Install piping to permit valve servicing.
- F. Install piping at indicated slopes.
- G. Install piping free of sags and bends.
- H. Install fittings for changes in direction and branch connections.
- I. Install piping to allow application of insulation.
- J. Install seismic restraints on piping. Comply with requirements for seismic-restraint devices specified in Division 22 Section "Vibration and Seismic Controls for Plumbing Piping and Equipment."
- K. Make changes in direction for soil and waste drainage and vent piping using appropriate branches, bends, and long-sweep bends. Sanitary tees and short-sweep 1/4 bends may be used on vertical stacks if change in direction of flow is from horizontal to vertical. Use long-turn, double Y-branch and 1/8-bend fittings if two fixtures are installed back to back or side by side with common drain pipe. Straight tees, elbows, and crosses may be used on vent lines. Do not change direction of flow more than 90 degrees. Use proper size of standard increasers and reducers if pipes of different sizes are connected. Reducing size of drainage piping in direction of flow is prohibited.
- L. Lay buried building drainage piping beginning at low point of each system. Install true to grades and alignment indicated, with unbroken continuity of invert. Place hub ends of piping upstream. Install required gaskets according to manufacturer's written instructions for use of lubricants, cements, and other installation requirements. Maintain swab in piping and pull past each joint as completed.
- M. Install soil and waste drainage and vent piping at the following minimum slopes unless otherwise indicated:
 1. Building Sanitary Drain: 2 percent downward in direction of flow for piping **NPS 3** and smaller; 1 percent downward in direction of flow for piping **NPS 4** and larger.
 2. Horizontal Sanitary Drainage Piping: 2 percent downward in direction of flow.
 3. Vent Piping: 1 percent down toward vertical fixture vent or toward vent stack.
- N. Install cast-iron soil piping according to CISPI's "Cast Iron Soil Pipe and Fittings Handbook," Chapter IV, "Installation of Cast Iron Soil Pipe and Fittings."
 1. Install encasement on underground piping according to ASTM A 674 or AWWA C105/A 21.5.
- O. Install stainless-steel piping according to ASME A112.3.1 and applicable plumbing code.
- P. Install aboveground copper tubing according to CDA's "Copper Tube Handbook."
- Q. Install underground PVC piping according to ASTM D 2321.

- R. Install engineered soil and waste drainage and vent piping systems as follows:
 - 1. Combination Waste and Vent: Comply with standards of authorities having jurisdiction.
 - 2. Solvent Drainage System: Comply with ASSE 1043 and solvent fitting manufacturer's written installation instructions.
 - 3. Reduced-Size Venting: Comply with standards of authorities having jurisdiction.
 - 4. Install encasement on piping according to ASTM A 674 or AWWA C105/A 21.5.

- S. Plumbing Specialties:
 - 1. Install backwater valves in sanitary waster gravity-flow piping. Comply with requirements for backwater valves specified in Division 22 Section "Sanitary Waste Piping Specialties."
 - 2. Install cleanouts at grade and extend to where building sanitary drains connect to building sanitary sewers in sanitary drainage gravity-flow piping. Install cleanout fitting with closure plug inside the building in sanitary drainage force-main piping. Comply with requirements for cleanouts specified in Division 22 Section "Sanitary Waste Piping Specialties."
 - 3. Install drains in sanitary drainage gravity-flow piping. Comply with requirements for drains specified in Division 22 Section "Sanitary Waste Piping Specialties."

- T. Do not enclose, cover, or put piping into operation until it is inspected and approved by authorities having jurisdiction.

- U. Install sleeves for piping penetrations of walls, ceilings, and floors. Comply with requirements for sleeves specified in Division 22 Section "Sleeves and Sleeve Seals for Plumbing Piping."

- V. Install sleeve seals for piping penetrations of concrete walls and slabs. Comply with requirements for sleeve seals specified in Division 22 Section "Sleeves and Sleeve Seals for Plumbing Piping."

- W. Install escutcheons for piping penetrations of walls, ceilings, and floors. Comply with requirements for escutcheons specified in Division 22 Section "Escutcheons for Plumbing Piping."

51.3 JOINT CONSTRUCTION

- A. Join hub-and-spigot, cast-iron soil piping with gasket joints according to CISPI's "Cast Iron Soil Pipe and Fittings Handbook" for compression joints.
- B. Join hub-and-spigot, cast-iron soil piping with calked joints according to CISPI's "Cast Iron Soil Pipe and Fittings Handbook" for lead-and-oakum calked joints.
- C. Join hubless, cast-iron soil piping according to CISPI 310 and CISPI's "Cast Iron Soil Pipe and Fittings Handbook" for hubless-piping coupling joints.
- D. Threaded Joints: Thread pipe with tapered pipe threads according to ASME B1.20.1. Cut threads full and clean using sharp dies. Ream threaded pipe ends to remove burrs and restore full ID. Join pipe fittings and valves as follows:

1. Apply appropriate tape or thread compound to external pipe threads unless dry seal threading is specified.
 2. Damaged Threads: Do not use pipe or pipe fittings with threads that are corroded or damaged. Do not use pipe sections that have cracked or open welds.
- E. Join stainless-steel pipe and fittings with gaskets according to ASME A112.3.1.
- F. Join copper tube and fittings with soldered joints according to ASTM B 828. Use ASTM B 813, water-flushable, lead-free flux and ASTM B 32, lead-free-alloy solder.
- G. Grooved Joints: Cut groove ends of pipe according to AWWA C606. Lubricate and install gasket over ends of pipes or pipe and fitting. Install coupling housing sections, over gasket, with keys seated in piping grooves. Install and tighten housing bolts.
- H. Flanged Joints: Align bolt holes. Select appropriate gasket material, size, type, and thickness. Install gasket concentrically positioned. Use suitable lubricants on bolt threads. Torque bolts in cross pattern.
- I. Plastic, Nonpressure-Piping, Solvent-Cement Joints: Clean and dry joining surfaces. Join pipe and fittings according to the following:
1. Comply with ASTM F 402 for safe-handling practice of cleaners, primers, and solvent cements.
 2. ABS Piping: Join according to ASTM D 2235 and ASTM D 2661 Appendixes.
 3. PVC Piping: Join according to ASTM D 2855 and ASTM D 2665 Appendixes.

51.4 SPECIALTY PIPE FITTING INSTALLATION

A. Transition Couplings:

1. Install transition couplings at joints of piping with small differences in OD's.
2. In Drainage Piping: Shielded, nonpressure transition couplings.
3. In Aboveground Force Main Piping: Fitting-type transition couplings.
4. In Underground Force Main Piping:
 - a. **NPS 1-1/2** and Smaller: Fitting-type transition couplings.
 - b. **NPS 2** and Larger: Pressure transition couplings.

B. Dielectric Fittings:

1. Install dielectric fittings in piping at connections of dissimilar metal piping and tubing.
2. Dielectric Fittings for **NPS 2** and Smaller: Use dielectric unions.
3. Dielectric Fittings for **NPS 2-1/2 to NPS 4**. Use dielectric flange kits.
4. Dielectric Fittings for **NPS 5** and Larger: Use dielectric flange kits.

51.5 VALVE INSTALLATION

A. General valve installation requirements are specified in Division 22 Section "General-Duty Valves for Plumbing Piping."

B. Shutoff Valves:

1. Install shutoff valve on each sewage pump discharge.
 2. Install gate or full-port ball valve for piping **NPS 2** and smaller.
 3. Install gate valve for piping **NPS 2-1/2** and larger.
- C. Check Valves: Install swing check valve, between pump and shutoff valve, on each sewage pump discharge.
- D. Backwater Valves: Install backwater valves in piping subject to backflow.
1. Horizontal Piping: Horizontal backwater valves.
 2. Floor Drains: Drain outlet backwater valves unless drain has integral backwater valve.
 3. Install backwater valves in accessible locations.
 4. Comply with requirements for backwater valve specified in Division 22 Section "Sanitary Waste Piping Specialties."

51.6 HANGER AND SUPPORT INSTALLATION

- A. Comply with requirements for seismic-restraint devices specified in Division 22 Section "Vibration and Seismic Controls for Plumbing Piping and Equipment."
- B. Comply with requirements for pipe hanger and support devices and installation specified in Division 22 Section "Hangers and Supports for Plumbing Piping and Equipment."
1. Install carbon-steel pipe hangers for horizontal piping in noncorrosive environments.
 2. Install carbon-steel pipe support clamps for vertical piping in noncorrosive environments.
 3. Install stainless-steel pipe support clamps for vertical piping in corrosive environments.
 4. Vertical Piping: MSS Type 8 or Type 42, clamps.
 5. Install individual, straight, horizontal piping runs:
 - a. **100 Feet** and Less: MSS Type 1, adjustable, steel clevis hangers.
 - b. Longer Than **100 Feet**: MSS Type 43, adjustable roller hangers.
 - c. Longer Than **100 Feet** if Indicated: MSS Type 49, spring cushion rolls.
 6. Multiple, Straight, Horizontal Piping Runs **100 Feet** or Longer: MSS Type 44, pipe rolls. Support pipe rolls on trapeze.
 7. Base of Vertical Piping: MSS Type 52, spring hangers.
- C. Support horizontal piping and tubing within **12 inches** of each fitting and coupling.
- D. Support vertical piping and tubing at base and at each floor.
- E. Rod diameter may be reduced one size for double-rod hangers, with **3/8-inch** minimum rods.
- F. Install hangers for cast-iron soil piping with the following maximum horizontal spacing and minimum rod diameters:
1. **NPS 1-1/2 and NPS 2**: **60 inches** with **3/8-inch** rod.
 2. **NPS 3**: **60 inches** with **1/2-inch** rod.
 3. **NPS 4 and NPS 5**: **60 inches** with **5/8-inch** rod.
 4. **NPS 6 and NPS 8**: **60 inches** with **3/4-inch** rod.

5. **NPS 10 and NPS 12: 60 inches** with **7/8-inch** rod.
 6. Spacing for **10-foot** lengths may be increased to **10 feet**. Spacing for fittings is limited to **60 inches**.
- G. Install supports for vertical cast-iron soil piping every **15 feet**.
- H. Install hangers for copper tubing with the following maximum horizontal spacing and minimum rod diameters:
1. **NPS 1-1/4: 72 inches** with **3/8-inch** rod.
 2. **NPS 1-1/2 and NPS 2: 96 inches** with **3/8-inch** rod.
 3. **NPS 2-1/2: 108 inches** with **1/2-inch** rod.
 4. **NPS 3 and NPS 5: 10 feet** with **1/2-inch** rod.
 5. **NPS 6: 10 feet** with **5/8-inch** rod.
 6. **NPS 8: 10 feet** with **3/4-inch** rod.
- I. Install supports for vertical copper tubing every **10 feet**.
- J. Support piping and tubing not listed above according to MSS SP-69 and manufacturer's written instructions.

51.7 CONNECTIONS

- A. Drawings indicate general arrangement of piping, fittings, and specialties.
- B. Connect soil and waste piping to exterior sanitary sewerage piping. Use transition fitting to join dissimilar piping materials.
- C. Connect drainage and vent piping to the following:
1. Plumbing Fixtures: Connect drainage piping in sizes indicated, but not smaller than required by plumbing code.
 2. Plumbing Fixtures and Equipment: Connect atmospheric vent piping in sizes indicated, but not smaller than required by authorities having jurisdiction.
 3. Plumbing Specialties: Connect drainage and vent piping in sizes indicated, but not smaller than required by plumbing code.
 4. Install test tees (wall cleanouts) in conductors near floor and floor cleanouts with cover flush with floor.
 5. Comply with requirements for backwater valves cleanouts and drains specified in Division 22 Section "Sanitary Waste Piping Specialties."
 6. Equipment: Connect drainage piping as indicated. Provide shutoff valve if indicated and union for each connection. Use flanges instead of unions for connections **NPS 2-1/2** and larger.
- D. Where installing piping adjacent to equipment, allow space for service and maintenance of equipment.
- E. Make connections according to the following unless otherwise indicated:
1. Install unions, in piping **NPS 2** and smaller, adjacent to each valve and at final connection to each piece of equipment.
 2. Install flanges, in piping **NPS 2-1/2** and larger, adjacent to flanged valves and at final connection to each piece of equipment.

51.8 IDENTIFICATION

- A. Identify exposed sanitary waste and vent piping. Comply with requirements for identification specified in Division 22 Section "Identification for Plumbing Piping and Equipment."

51.9 FIELD QUALITY CONTROL

- A. During installation, notify authorities having jurisdiction at least 24 hours before inspection must be made. Perform tests specified below in presence of authorities having jurisdiction.
 - 1. Roughing-in Inspection: Arrange for inspection of piping before concealing or closing-in after roughing-in and before setting fixtures.
 - 2. Final Inspection: Arrange for final inspection by authorities having jurisdiction to observe tests specified below and to ensure compliance with requirements.
- B. Reinspection: If authorities having jurisdiction find that piping will not pass test or inspection, make required corrections and arrange for reinspection.
- C. Reports: Prepare inspection reports and have them signed by authorities having jurisdiction.
- D. Test sanitary drainage and vent piping according to procedures of authorities having jurisdiction or, in absence of published procedures, as follows:
 - 1. Test for leaks and defects in new piping and parts of existing piping that have been altered, extended, or repaired. If testing is performed in segments, submit separate report for each test, complete with diagram of portion of piping tested.
 - 2. Leave uncovered and unconcealed new, altered, extended, or replaced drainage and vent piping until it has been tested and approved. Expose work that was covered or concealed before it was tested.
 - 3. Roughing-in Plumbing Test Procedure: Test drainage and vent piping except outside leaders on completion of roughing-in. Close openings in piping system and fill with water to point of overflow, but not less than **10-foot head of water**. From 15 minutes before inspection starts to completion of inspection, water level must not drop. Inspect joints for leaks.
 - 4. Finished Plumbing Test Procedure: After plumbing fixtures have been set and traps filled with water, test connections and prove they are gastight and watertight. Plug vent-stack openings on roof and building drains where they leave building. Introduce air into piping system equal to pressure of **1-inch wg**. Use U-tube or manometer inserted in trap of water closet to measure this pressure. Air pressure must remain constant without introducing additional air throughout period of inspection. Inspect plumbing fixture connections for gas and water leaks.
 - 5. Repair leaks and defects with new materials and retest piping, or portion thereof, until satisfactory results are obtained.
 - 6. Prepare reports for tests and required corrective action.

51.10 CLEANING AND PROTECTION

- A. Clean interior of piping. Remove dirt and debris as work progresses.

- B. Protect drains during remainder of construction period to avoid clogging with dirt and debris and to prevent damage from traffic and construction work.
- C. Place plugs in ends of uncompleted piping at end of day and when work stops.

51.11 PIPING SCHEDULE

- A. Flanges and unions may be used on aboveground pressure piping unless otherwise indicated.
- B. Aboveground, soil and waste piping **NPS 5** and larger shall be any of the following:
 1. Service class, cast-iron soil pipe and fittings; gaskets; and gasketed joints.
 2. Hubless, cast-iron soil pipe and fittings CISPI hubless-piping couplings; and coupled joints.
 3. Dissimilar Pipe-Material Couplings: Shielded, nonpressure transition couplings.
- C. Aboveground, vent piping **NPS 4** and smaller shall be any of the following:
 1. Service class, cast-iron soil pipe and fittings; gaskets; and gasketed joints.
 2. Hubless, cast-iron soil pipe and fittings; CISPI hubless-piping couplings; and coupled joints.
 3. Copper DWV tube, copper drainage fittings, and soldered joints.
 - a. Option for Vent Piping, **NPS 2-1/2 and NPS 3-1/2**: Hard copper tube, **Type M (Type C)**; copper pressure fittings; and soldered joints.
 4. Dissimilar Pipe-Material Couplings: Shielded, nonpressure transition couplings.
- D. Aboveground, vent piping **NPS 5** and larger shall be any of the following:
 1. Service class, cast-iron soil pipe and fittings; gaskets; and gasketed joints.
 2. Hubless, cast-iron soil pipe and fittings; CISPI hubless-piping couplings; and coupled joints.
 3. Galvanized-steel pipe, drainage fittings, and threaded joints.
 4. Dissimilar Pipe-Material Couplings: Shielded, nonpressure transition couplings.
- E. Underground, soil, waste, and vent piping **NPS 4** and smaller shall be any of the following:
 1. Extra Heavy class, cast-iron soil piping; gaskets; and gasketed.
 2. Hubless, cast-iron soil pipe and fittings; heavy-duty cast-iron hubless-piping couplings; and coupled joints.
 3. Solid wall PVC pipe, PVC socket fittings, and solvent-cemented joints.
 4. Dissimilar Pipe-Material Couplings: Shielded, nonpressure transition couplings.
- F. Underground, soil and waste piping **NPS 5** and larger shall be any of the following:
 1. Extra Heavy class, cast-iron soil piping; gaskets; and gasketed joints.
 2. Hubless, cast-iron soil pipe and fittings; heavy-duty cast-iron hubless-piping couplings; coupled joints.
 3. Solid-wall PVC pipe; PVC socket fittings; and solvent-cemented joints.
 4. Dissimilar Pipe-Material Couplings: Shielded, nonpressure transition couplings.

END OF SECTION

SECTION 221319 - SANITARY WASTE PIPING SPECIALTIES

PART 53 - GENERAL

53.1 RELATED DOCUMENTS

- A. Drawings and general provisions of the Contract, including General and Supplementary Conditions and Division 01 Specification Sections, apply to this Section.

53.2 SUMMARY

- A. This Section includes the following sanitary drainage piping specialties:
 - 1. Cleanouts.
 - 2. Floor drains.
 - 3. Roof flashing assemblies.
 - 4. Through-penetration firestop assemblies.
 - 5. Miscellaneous sanitary drainage piping specialties.
 - 6. Flashing materials.
 - 7. Grease Interceptor.
- B. Related Sections include the following:
 - 1. Division 22 Section "Storm Drainage Piping Specialties" for trench drains for storm water, channel drainage systems for storm water, roof drains, and catch basins.
 - 2. Division 22 Section "Security Plumbing Fixtures" for hair interceptors.

53.3 DEFINITIONS

- A. ABS: Acrylonitrile-butadiene-styrene plastic.
- B. FOG: Fats, oils, and greases.
- C. FRP: Fiberglass-reinforced plastic.
- D. HDPE: High-density polyethylene plastic.
- E. PE: Polyethylene plastic.
- F. PP: Polypropylene plastic.
- G. PVC: Polyvinyl chloride plastic.

53.4 SUBMITTALS

- A. Product Data: For each type of product indicated. Include rated capacities, operating characteristics, and accessories for the following:

1. Grease interceptors.
- B. Shop Drawings: Show fabrication and installation details for frost-resistant vent terminals.
 1. Wiring Diagrams: Power, signal, and control wiring.
- C. Field quality-control test reports.
- D. Operation and Maintenance Data: For drainage piping specialties to include in emergency, operation, and maintenance manuals.

53.5 QUALITY ASSURANCE

- A. Drainage piping specialties shall bear label, stamp, or other markings of specified testing agency.
- B. Electrical Components, Devices, and Accessories: Listed and labeled as defined in NFPA 70, Article 100, by a testing agency acceptable to authorities having jurisdiction, and marked for intended use.
- C. Comply with NSF 14, "Plastics Piping Components and Related Materials," for plastic sanitary piping specialty components.

53.6 COORDINATION

- A. Coordinate size and location of concrete bases. Cast anchor-bolt inserts into bases. Concrete, reinforcement, and formwork requirements are specified in Division 03.
- B. Coordinate size and location of roof penetrations.

53.7 EXTRA MATERIALS

1. Furnish extra materials described below that match products installed and that are packaged with protective covering for storage and identified with labels describing contents.
 1. Cultures: Provide 1-gal. (3.8-L) bottles of bacteria culture recommended by manufacturer of FOG disposal systems equal to 200 percent of amount installed, but no fewer than 2 1-gal. (3.8-L) bottles.

PART 54 - PRODUCTS

54.1 CLEANOUTS

- A. Exposed Metal Cleanouts
 1. Manufacturers: Subject to compliance with requirements, provide products by one of the following:
 - a. Josam Company; Josam Div.

- b. MIFAB, Inc.
 - c. Smith, Jay R. Mfg. Co.; Division of Smith Industries, Inc.
 - d. Tyler Pipe; Wade Div.
 - e. Watts Drainage Products Inc.
 - f. Zurn Plumbing Products Group; Specification Drainage Operation.
 - g. Josam Company; Blucher-Josam Div.
2. Standard: ASME A112.36.2M for cast iron for cleanout test tee.
 3. Size: Same as connected drainage piping
 4. Body Material: Hubless, cast-iron soil pipe test tee as required to match connected piping.
 5. Closure: Countersunk or raised-head plug.
 6. Closure Plug Size: Same as or not more than one size smaller than cleanout size.
 7. Closure: Stainless-steel plug with seal.

B. Metal Floor Cleanouts:

1. Manufacturers: Subject to compliance with requirements, provide products by one of the following:
 - a. Josam Company; Josam Div.
 - b. Oatey.
 - c. Sioux Chief Manufacturing Company, Inc.
 - d. Smith, Jay R. Mfg. Co.; Division of Smith Industries, Inc.
 - e. Tyler Pipe; Wade Div.
 - f. Watts Drainage Products Inc.
 - g. Zurn Plumbing Products Group; Light Commercial Operation.
 - h. Zurn Plumbing Products Group; Specification Drainage Operation.
 - i. Josam Company; Josam Div.
 - j. Kusel Equipment Co.
 - k. Smith, Jay R. Mfg. Co.; Division of Smith Industries, Inc.
 - l. Josam Company; Blucher-Josam Div.
2. Standard: ASME A112.36.2M for adjustable housing cleanout.
3. Size: Same as connected branch.
4. Type: Adjustable housing
5. Body or Ferrule: Cast iron
6. Clamping Device: Required.
7. Outlet Connection: Inside calk
8. Closure: Brass plug with tapered threads
9. Adjustable Housing Material: Cast iron with set-screws or other device.
10. Frame and Cover Material and Finish: Nickel-bronze, copper alloy
11. Frame and Cover Shape: Round
12. Top Loading Classification: Medium Duty.
13. Riser: ASTM A 74, Service class, cast-iron drainage pipe fitting and riser to cleanout.
14. Standard: ASME A112.3.1.
15. Size: Same as connected branch.
16. Housing: Stainless steel.
17. Closure: Stainless steel with seal.
18. Riser: Stainless-steel drainage pipe fitting to cleanout.

C. Cast-Iron Wall Cleanouts

1. Manufacturers: Subject to compliance with requirements, provide products by one of the following:
 - a. Josam Company; Josam Div.
 - b. MIFAB, Inc.
 - c. Smith, Jay R. Mfg. Co.; Division of Smith Industries, Inc.
 - d. Tyler Pipe; Wade Div.
 - e. Watts Drainage Products Inc.
 - f. Zurn Plumbing Products Group; Specification Drainage Operation.
2. Standard: ASME A112.36.2M. Include wall access.
3. Size: Same as connected drainage piping.
4. Body: Hubless, cast-iron soil pipe test tee as required to match connected piping.
5. Closure: Countersunk or raised-head plug.
6. Closure Plug Size: Same as or not more than one size smaller than cleanout size.
7. Wall Access: Round, flat, chrome-plated brass or stainless-steel cover plate with screw.
8. Wall Access: Round, nickel-bronze, copper-alloy, or stainless-steel wall-installation frame and cover.

54.2 FLOOR DRAINS

A. Cast-Iron Floor Drains:

1. Manufacturers: Subject to compliance with requirements, provide products by one of the following:
 - a. Commercial Enameling Co.
 - b. Josam Company; Josam Div.
 - c. MIFAB, Inc.
 - d. Prier Products, Inc.
 - e. Smith, Jay R. Mfg. Co.; Division of Smith Industries, Inc.
 - f. Tyler Pipe; Wade Div.
 - g. Watts Drainage Products Inc.
 - h. Zurn Plumbing Products Group; Light Commercial Operation.
 - i. Zurn Plumbing Products Group; Specification Drainage Operation.
2. Standard: ASME A112.6.3.
3. Pattern: Floor drain.
4. Body Material: Cast iron
5. Seepage Flange: Required.
6. Anchor Flange: Required.
7. Clamping Device: Required.
8. Outlet: Bottom
9. Backwater Valve: Not required.
10. Coating on Interior and Exposed Exterior Surfaces: Not required.
11. Sediment Bucket: Not required
12. Top or Strainer Material: Nickel bronze
13. Top of Body and Strainer Finish: Nickel bronze
14. Top Shape: Round
15. Inlet Fitting: Gray iron, with threaded inlet and threaded or spigot outlet, and trap-seal primer valve connection.

16. Trap Material: Cast iron
17. Trap Pattern: Standard P-trap.
18. Trap Features: Trap-seal primer valve drain connection.

54.3 ROOF FLASHING ASSEMBLIES

A. Roof Flashing Assemblies:

1. Manufacturers: Subject to compliance with requirements, provide products by one of the following:
 - a. Acorn Engineering Company; Elmdor/Stoneman Div.
 - b. Thaler Metal Industries Ltd.

B. Description: Manufactured assembly made of 4.0-lb/sq. ft. (20-kg/sq. m), 0.0625-inch- (1.6-mm-) from pipe, with galvanized-steel boot reinforcement and counterflashing fitting.

1. Open-Top Vent Cap: Without cap.
2. Low-Silhouette Vent Cap: With vandal-proof vent cap.
3. Extended Vent Cap: With field-installed, vandal-proof vent cap.

54.4 THROUGH-PENETRATION FIRESTOP ASSEMBLIES

A. Through-Penetration Firestop Assemblies:

1. Manufacturers: Subject to compliance with requirements, provide products by one of the following:
 - a. ProSet Systems Inc.
2. Standard: UL 1479 assembly of sleeve and stack fitting with firestopping plug.
3. Size: Same as connected soil, waste, or vent stack.
4. Sleeve: Molded PVC plastic, of length to match slab thickness and with integral nailing flange on one end for installation in cast-in-place concrete slabs.
5. Stack Fitting: ASTM A 48/A 48M, gray-iron, hubless-pattern, wye branch with neoprene O-ring at base and gray-iron plug in thermal-release harness. Include PVC protective cap for plug.
6. Special Coating: Corrosion resistant on interior of fittings.

54.5 MISCELLANEOUS SANITARY DRAINAGE PIPING SPECIALTIES

A. Open Drains:

1. Description: Shop or field fabricate from ASTM A 74, Service class, hub-and-spigot, cast-iron, soil-pipe fittings. Include P-trap, hub-and-spigot riser section; and where required, increaser fitting joined with ASTM C 564, rubber gaskets.
2. Size: Same as connected waste piping.

B. Deep-Seal Traps:

1. Description: Cast-iron or bronze casting, with inlet and outlet matching connected piping and cleanout trap-seal primer valve connection.
2. Size: Same as connected waste piping.
 - a. NPS 2 (DN 50): 4-inch- (100-mm-) minimum water seal.
 - b. NPS 2-1/2 (DN 65) and Larger: 5-inch- (125-mm-) minimum water seal.

C. Floor-Drain, Trap-Seal Primer Fittings:

1. Description: Cast iron, with threaded inlet and threaded or spigot outlet, and trap-seal primer valve connection.
2. Size: Same as floor drain outlet with NPS 1/2 (DN 15) side inlet.

D. Air-Gap Fittings :

1. Standard: ASME A112.1.2, for fitting designed to ensure fixed, positive air gap between installed inlet and outlet piping.
2. Body: Bronze or cast iron.
3. Inlet: Opening in top of body.
4. Outlet: Larger than inlet.
5. Size: Same as connected waste piping and with inlet large enough for associated indirect waste piping.

E. Sleeve Flashing Device:

1. Description: Manufactured, cast-iron fitting, with clamping device, that forms sleeve for pipe floor penetrations of floor membrane. Include galvanized-steel pipe extension in top of fitting that will extend 2 inches (51 mm) above finished floor and galvanized-steel pipe extension in bottom of fitting that will extend through floor slab.
2. Size: As required for close fit to riser or stack piping.

F. Stack Flashing Fittings:

1. Description: Counterflashing-type, cast-iron fitting, with bottom recess for terminating roof membrane, and with threaded or hub top for extending vent pipe.
2. Size: Same as connected stack vent or vent stack.

G. Expansion Joints

1. Standard: ASME A112.21.2M.
2. Body: Cast iron with bronze sleeve, packing, and gland.
3. End Connections: Matching connected piping.
4. Size: Same as connected soil, waste, or vent piping.

54.6 FLASHING MATERIALS

A. Lead Sheet: ASTM B 749, Type L51121, copper bearing, with the following minimum weights and thicknesses, unless otherwise indicated:

1. General Use: 4.0-lb/sq. ft. (20-kg/sq. m), 0.0625-inch (1.6-mm) thickness.
2. Vent Pipe Flashing: 3.0-lb/sq. ft. (15-kg/sq. m), 0.0469-inch (1.2-mm) thickness.
3. Burning: 6-lb/sq. ft. (30-kg/sq. m), 0.0938-inch (2.4-mm) thickness.

- B. Copper Sheet: ASTM B 152/B 152M, of the following minimum weights and thicknesses, unless otherwise indicated:
 - 1. General Applications: 12 oz./sq. ft. (3.7 kg/sq. m or 0.41-mm) thickness.
 - 2. Vent Pipe Flashing: 8 oz./sq. ft. (2.5 kg/sq. m or 0.27-mm) thickness.
- C. Zinc-Coated Steel Sheet: ASTM A 653/A 653M, with 0.20 percent copper content and 0.04-inch (1.01-mm) minimum thickness, unless otherwise indicated. Include G90 (Z275) hot-dip galvanized, mill-phosphatized finish for painting if indicated.
- D. Elastic Membrane Sheet: ASTM D 4068, flexible, chlorinated polyethylene, 40-mil (1.01-mm) minimum thickness.
- E. Fasteners: Metal compatible with material and substrate being fastened.
- F. Metal Accessories: Sheet metal strips, clamps, anchoring devices, and similar accessory units required for installation; matching or compatible with material being installed.
- G. Solder: ASTM B 32, lead-free alloy.
- H. Bituminous Coating: SSPC-Paint 12, solvent-type, bituminous mastic.

54.7 EXTERIOR GREASE INTERCEPTOR – SPECIFICATIONS

- A. References:
 - 1. ASTM C1613-06 Standard Specifications for Precast Grease Interceptor Tanks
 - 2. ASTM C 890-06 Standard for Waste Water Structures
 - 3. ASTM C 318-02 Standard for Reinforced Concrete
- B. Manufacturers
- C. Precast concrete grease interceptor to meet ASTM and or state design requirements. Tank to be engineered, watertight, and capable of withstanding loading conditions for this project per drawings. Tank to comply with ASTM C-1613-06.
- D. Provide minimum 24" diameter concrete manholes spaced within a minimum of 8' opening increments to facilitate pumping. Furnish cast iron frame and covers with gas tight, bolted access lids. Manholes shall be provided with warning labels affixed or cast into covers.
- E. Inlet and outlet piping joints to be furnished with rubber boots meeting ASTM C923.
- F. Execution: Excavate for exterior grease interceptor, setting precast bases on granular compacted base of 6" stone or sand under ¾". Base material shall support weight of tank and back fill without settlement. Seal joints between base, top sections, risers and castings with EZ stick mastic per ASTM C990. Back fill and compact soil around grease interceptor in 12" lifts. Back fill material to be dry and under 3" size. Tank shall be vacuum tested after installation to insure structure is watertight per ASTM 1663-06 using 4 inch of mercury for 5 minutes or to meet state codes.

PART 55 - EXECUTION

55.1 INSTALLATION

- A. Refer to Section 220000 "General Plumbing Requirements" for piping joining materials, joint construction, and basic installation requirements.
- B. Install backwater valves in building drain piping. For interior installation, provide cleanout deck plate flush with floor and centered over backwater valve cover, and of adequate size to remove valve cover for servicing.
- C. Install cleanouts in aboveground piping and building drain piping according to the following, unless otherwise indicated:
 - 1. Size same as drainage piping up to **NPS 4 (DN 100)**. Use **NPS 4 (DN 100)** for larger drainage piping unless larger cleanout is indicated.
 - 2. Locate at each change in direction of piping greater than 45 degrees.
 - 3. Locate at minimum intervals of **50 feet (15 m)** for piping **NPS 4 (DN 100)** and smaller and **100 feet (30 m)** for larger piping.
 - 4. Locate at base of each vertical soil and waste stack.
- D. For floor cleanouts for piping below floors, install cleanout deck plates with top flush with finished floor.
- E. For cleanouts located in concealed piping, install cleanout wall access covers, of types indicated, with frame and cover flush with finished wall.
- F. Install floor drains at low points of surface areas to be drained. Set grates of drains flush with finished floor, unless otherwise indicated.
 - 1. Position floor drains for easy access and maintenance.
 - 2. Set floor drains below elevation of surrounding finished floor to allow floor drainage. Set with grates depressed according to the following drainage area radii:
 - a. Radius, **30 Inches (750 mm)** or Less: Equivalent to 1 percent slope, but not less than **1/4-inch (6.35-mm)** total depression.
 - b. Radius, **30 to 60 Inches (750 to 1500 mm)**: Equivalent to 1 percent slope.
 - c. Radius, **60 Inches (1500 mm)** or Larger: Equivalent to 1 percent slope, but not greater than **1-inch (25-mm)** total depression.
 - 3. Install floor-drain flashing collar or flange so no leakage occurs between drain and adjoining flooring. Maintain integrity of waterproof membranes where penetrated.
 - 4. Install individual traps for floor drains connected to sanitary building drain, unless otherwise indicated.
- G. Install roof flashing assemblies on sanitary stack vents and vent stacks that extend through roof.
- H. Install flashing fittings on sanitary stack vents and vent stacks that extend through roof.
- I. Assemble open drain fittings and install with top of hub **2 inches (51 mm)** above floor.
- J. Install deep-seal traps on floor drains and other waste outlets, if indicated.

- K. Install floor-drain, trap-seal primer fittings on inlet to floor drains that require trap-seal primer connection.
 - 1. Exception: Fitting may be omitted if trap has trap-seal primer connection.
 - 2. Size: Same as floor drain inlet.
- L. Install air-gap fittings on draining-type backflow preventers and on indirect-waste piping discharge into sanitary drainage system.
- M. Install sleeve flashing device with each riser and stack passing through floors with waterproof membrane.
- N. Install vent caps on each vent pipe passing through roof.
- O. Install frost-resistant vent terminals on each vent pipe passing through roof. Maintain 1-inch (25-mm) clearance between vent pipe and roof substrate.
- P. Install expansion joints on vertical stacks and conductors. Position expansion joints for easy access and maintenance.
- Q. Install frost-proof vent caps on each vent pipe passing through roof. Maintain 1-inch (25-mm) clearance between vent pipe and roof substrate.
- R. Install wood-blocking reinforcement for wall-mounting-type specialties.
- S. Install traps on plumbing specialty drain outlets. Omit traps on indirect wastes unless trap is indicated.

55.2 CONNECTIONS

- A. Piping installation requirements are specified in other Division 22 Sections. Drawings indicate general arrangement of piping, fittings, and specialties.
- B. Install piping adjacent to equipment to allow service and maintenance.
- C. FOG Disposal Systems: Connect inlet and outlet to unit, connect flow-control fitting and fresh-air inlet piping to unit inlet piping, and connect vent piping between trap and media chamber. Connect electrical power.
- D. Grease Interceptors: Connect inlet and outlet to unit, and connect flow-control fitting and vent to unit inlet piping. Install valve on outlet of automatic drawoff-type unit.
- E. Grease Removal Devices: Connect controls, electrical power, factory-furnished accessories, and inlet, outlet, and vent piping to unit.
- F. Oil Interceptors: Connect inlet, outlet, vent, and gravity drawoff piping to unit; flow-control fitting and vent to unit inlet piping; and gravity drawoff and suction piping to oil storage tank.
- G. Ground equipment according to Division 26 Section "Grounding and Bonding for Electrical Systems."
- H. Connect wiring according to Division 26 Section "Low-Voltage Electrical Power Conductors and Cables."

55.3 FLASHING INSTALLATION

- A. Fabricate flashing from single piece unless large pans, sumps, or other drainage shapes are required. Join flashing according to the following if required:
 - 1. Lead Sheets: Burn joints of lead sheets **6.0-lb/sq. ft. (30-kg/sq. m)**, **0.0938-inch (2.4-mm)** thickness or thicker. Solder joints of lead sheets **4.0-lb/sq. ft. (20-kg/sq. m)**, **0.0625-inch (1.6-mm)** thickness or thinner.
 - 2. Copper Sheets: Solder joints of copper sheets.
- B. Install sheet flashing on pipes, sleeves, and specialties passing through or embedded in floors and roofs with waterproof membrane.
 - 1. Pipe Flashing: Sleeve type, matching pipe size, with minimum length of **10 inches (250 mm)**, and skirt or flange extending at least **8 inches (200 mm)** around pipe.
 - 2. Sleeve Flashing: Flat sheet, with skirt or flange extending at least **8 inches (200 mm)** around sleeve.
 - 3. Embedded Specialty Flashing: Flat sheet, with skirt or flange extending at least **8 inches (200 mm)** around specialty.
- C. Set flashing on floors and roofs in solid coating of bituminous cement.
- D. Secure flashing into sleeve and specialty clamping ring or device.
- E. Install flashing for piping passing through roofs with counterflashing or commercially made flashing fittings, according to Division 07 Section "Sheet Metal Flashing and Trim."
- F. Extend flashing up vent pipe passing through roofs and turn down into pipe, or secure flashing into cast-iron sleeve having calking recess.
- G. Fabricate and install flashing and pans, sumps, and other drainage shapes.

55.4 FIELD QUALITY CONTROL

- A. Perform tests and inspections and prepare test reports.
- B. Tests and Inspections:
 - 1. Leak Test: After installation, charge system and test for leaks. Repair leaks and retest until no leaks exist.
 - 2. Test and adjust controls and safeties. Replace damaged and malfunctioning controls and equipment.

55.5 PROTECTION

- A. Protect drains during remainder of construction period to avoid clogging with dirt or debris and to prevent damage from traffic or construction work.
- B. Place plugs in ends of uncompleted piping at end of each day or when work stops.

END OF SECTION

SECTION 221413 - FACILITY STORM DRAINAGE PIPING

PART 57 - GENERAL

57.1 RELATED DOCUMENTS

- A. Drawings and general provisions of the Contract, including General and Supplementary Conditions and Division 01 Specification Sections, apply to this Section.

57.2 SUMMARY

- A. Section Includes:
 - 1. Pipe, tube, and fittings.
 - 2. Specialty pipe fittings.
 - 3. Encasement for underground metal piping.

57.3 PERFORMANCE REQUIREMENTS

- A. Components and installation shall be capable of withstanding the following minimum working pressure unless otherwise indicated:
 - 1. Storm Drainage Piping: 10-foot head of water (30 kPa).
- B. Seismic Performance: Storm drainage piping and support and installation shall withstand the effects of earthquake motions determined according to ASCE/SEI 7.

57.4 SUBMITTALS

- A. Product Data: For each type of product indicated.
- B. LEED Submittal:
 - 1. Product Data for Credit EQ 4.1: For solvent cements and adhesive primers, documentation including printed statement of VOC content.
- C. Seismic Qualification Certificates: For storm drainage piping, accessories, and components, from manufacturer.
 - 1. Basis for Certification: Indicate whether withstand certification is based on actual test of assembled components or on calculation.
 - 2. Detailed description of equipment anchorage devices on which the certification is based and their installation requirements.

- D. Field quality-control reports.

57.5 QUALITY ASSURANCE

- A. Piping materials shall bear label, stamp, or other markings of specified testing agency.
- B. Comply with NSF/ANSI 14, "Plastics Piping System Components and Related Materials," for plastic piping components. Include marking with "NSF-drain" for plastic drain piping and "NSF-sewer" for plastic sewer piping.

PART 58 - PRODUCTS

58.1 PIPING MATERIALS

- A. Comply with requirements in "Piping Schedule" Article for applications of pipe, tube, fitting materials, and joining methods for specific services, service locations, and pipe sizes.

58.2 HUB-AND-SPIGOT, CAST-IRON SOIL PIPE AND FITTINGS

- A. Pipe and Fittings: ASTM A 74, Service classes.
- B. Gaskets: ASTM C 564, rubber.
- C. Calking Materials: ASTM B 29, pure lead and oakum or hemp fiber.

58.3 HUBLESS, CAST-IRON SOIL PIPE AND FITTINGS

- A. Pipe and Fittings: ASTM A 888 or CISPI 301.
- B. CISPI, Hubless-Piping Couplings:
 - 1. Manufacturers: Subject to compliance with requirements, provide products by one of the following:
 - a. ANACO-Husky.
 - b. Dallas Specialty & Mfg. Co.
 - c. Fernco Inc.
 - d. Matco-Norca, Inc.
 - e. MIFAB, Inc.
 - f. Mission Rubber Company; a division of MCP Industries, Inc.
 - g. Stant.
 - h. Tyler Pipe.
 - 2. Standards: ASTM C 1277 and CISPI 310.
 - 3. Description: Stainless-steel corrugated shield with stainless-steel bands and tightening devices; and ASTM C 564, rubber sleeve with integral, center pipe stop.
- C. Heavy-Duty, Hubless-Piping Couplings:

1. Manufacturers: Subject to compliance with requirements, provide products by one of the following:
 - a. ANACO-Husky.
 - b. Clamp-All Corp.
 - c. Dallas Specialty & Mfg. Co.
 - d. MIFAB, Inc.
 - e. Mission Rubber Company; a division of MCP Industries, Inc.
 - f. Stant.
 - g. Tyler Pipe.
2. Standards: ASTM C 1277 and ASTM C 1540.
3. Description: Stainless-steel shield with stainless-steel bands and tightening devices; and ASTM C 564, rubber sleeve with integral, center pipe stop.

58.4 PVC PIPE AND FITTINGS

- A. Solid-Wall PVC Pipe: ASTM D 2665, drain, waste, and vent.
- B. PVC Socket Fittings: ASTM D 2665, made to ASTM D 3311, drain, waste, and vent patterns and to fit Schedule 40 pipe.
- C. Adhesive Primer: ASTM F 656.
 1. Use adhesive primer that has a VOC content of 550 g/L or less when calculated according to 40 CFR 59, Subpart D (EPA Method 24).
- D. Solvent Cement: ASTM D 2564.
 1. Use PVC solvent cement that has a VOC content of 510 g/L or less when calculated according to 40 CFR 59, Subpart D (EPA Method 24).

58.5 SPECIALTY PIPE FITTINGS

- A. Transition Couplings:
 1. General Requirements: Fitting or device for joining piping with small differences in OD's or of different materials. Include end connections same size as and compatible with pipes to be joined.
 2. Fitting-Type Transition Couplings: Manufactured piping coupling or specified-piping-system fitting.
 3. Shielded, Nonpressure Transition Couplings:
 - a. Manufacturers: Subject to compliance with requirements, provide products by one of the following:
 - 1) Cascade Waterworks Mfg. Co.
 - 2) Mission Rubber Company; a division of MCP Industries, Inc.
 - b. Standard: ASTM C 1460.

- c. Description: Elastomeric or rubber sleeve with full-length, corrosion-resistant outer shield and corrosion-resistant-metal tension band and tightening mechanism on each end.
4. Pressure Transition Couplings:
- a. Manufacturers: Subject to compliance with requirements, provide products by one of the following:
 - 1) Cascade Waterworks Mfg. Co.
 - 2) Dresser, Inc.
 - 3) EBAA Iron, Inc.
 - 4) Ford Meter Box Company, Inc. (The)
 - 5) JCM Industries, Inc.
 - 6) Romac Industries, Inc.
 - 7) Smith-Blair, Inc.; a Sensus company.
 - 8) Viking Johnson; c/o Mueller Co.
 - b. Standard: AWWA C219.
 - c. Description: Metal, sleeve-type couplings same size as, with pressure rating at least equal to and ends compatible with, pipes to be joined.
 - d. Center-Sleeve Material: Manufacturer's standard.
 - e. Gasket Material: Natural or synthetic rubber.
 - f. Metal Component Finish: Corrosion-resistant coating or material.
- B. Dielectric Fittings:
- 1. General Requirements: Assembly of copper alloy and ferrous materials with separating nonconductive insulating material. Include end connections compatible with pipes to be joined.
 - 2. Dielectric Unions:
 - a. Manufacturers: Subject to compliance with requirements, provide products by one of the following:
 - 1) Capitol Manufacturing Company.
 - 2) Central Plastics Company.
 - 3) Hart Industries International, Inc.
 - 4) Jomar International Ltd.
 - 5) Matco-Norca, Inc.
 - 6) McDonald, A. Y. Mfg. Co.
 - 7) Watts Regulator Co.; a division of Watts Water Technologies, Inc.
 - 8) Wilkins; a Zurn company.
 - b. Description:
 - 1) Standard: ASSE 1079.
 - 2) Pressure Rating: 150 psig at 180 deg F (82 deg C).
 - 3) End Connections: Solder-joint copper alloy and threaded ferrous.
 - 3. Dielectric Flanges:

- a. Manufacturers: Subject to compliance with requirements, provide products by one of the following:
 - 1) Capitol Manufacturing Company.
 - 2) Central Plastics Company.
 - 3) Matco-Norca, Inc.
 - 4) Watts Regulator Co.; a division of Watts Water Technologies, Inc.
 - 5) Wilkins; a Zurn company.
 - b. Description:
 - 1) Standard: ASSE 1079.
 - 2) Factory-fabricated, bolted, companion-flange assembly.
 - 3) Pressure Rating: 150 psig.
 - 4) End Connections: Solder-joint copper alloy and threaded ferrous; threaded solder-joint copper alloy and threaded ferrous.
4. Dielectric-Flange Insulating Kits:
- a. Manufacturers: Subject to compliance with requirements, provide products by one of the following:
 - 1) Advance Products & Systems, Inc.
 - 2) Calpico, Inc.
 - 3) Central Plastics Company.
 - 4) Pipeline Seal and Insulator, Inc.
 - b. Description:
 - 1) Nonconducting materials for field assembly of companion flanges.
 - 2) Pressure Rating: 150 psig.
 - 3) Gasket: Neoprene or phenolic.
 - 4) Bolt Sleeves: Phenolic or polyethylene.
 - 5) Washers: Phenolic with steel-backing washers.
5. Dielectric Nipples:
- a. Manufacturers: Subject to compliance with requirements, provide products by one of the following:
 - 1) Elster Perfection.
 - 2) Grinnell Mechanical Products.
 - 3) Matco-Norca, Inc.
 - 4) Precision Plumbing Products, Inc.
 - 5) Victaulic Company.
 - b. Description:
 - 1) Electroplated steel nipple complying with ASTM F 1545.
 - 2) Pressure Rating: 300 psig at 225 deg F.
 - 3) End Connections: Male threaded or grooved.
 - 4) Lining: Inert and noncorrosive, propylene.

PART 59 - EXECUTION

59.1 EARTH MOVING

- A. Comply with requirements for excavating, trenching, and backfilling specified in 2018 Greenbook Section 300.

59.2 PIPING INSTALLATION

- A. Drawing plans, schematics, and diagrams indicate general location and arrangement of piping systems. Indicated locations and arrangements were used to size pipe and calculate friction loss, expansion, pump sizing, and other design considerations. Install piping as indicated unless deviations from layout are approved on coordination drawings.
- B. Install piping in concealed locations unless otherwise indicated and except in equipment rooms and service areas.
- C. Install piping indicated to be exposed and piping in equipment rooms and service areas at right angles or parallel to building walls. Diagonal runs are prohibited unless specifically indicated otherwise.
- D. Install piping above accessible ceilings to allow sufficient space for ceiling panel removal.
- E. Install piping to permit valve servicing.
- F. Install piping at indicated slopes.
- G. Install piping free of sags and bends.
- H. Install fittings for changes in direction and branch connections.
- I. Install piping to allow application of insulation.
- J. Install seismic restraints on piping. Comply with requirements for seismic-restraint devices specified in Division 22 Section "Vibration and Seismic Controls for Plumbing Piping and Equipment."
- K. Make changes in direction for storm drainage piping using appropriate branches, bends, and long-sweep bends. Do not change direction of flow more than 90 degrees. Use proper size of standard increasers and reducers if pipes of different sizes are connected. Reducing size of drainage piping in direction of flow is prohibited.
- L. Lay buried building storm drainage piping beginning at low point of each system. Install true to grades and alignment indicated, with unbroken continuity of invert. Place hub ends of piping upstream. Install required gaskets according to manufacturer's written instructions for use of lubricants, cements, and other installation requirements. Maintain swab in piping and pull past each joint as completed.
- M. Install storm drainage piping at the following minimum slopes unless otherwise indicated:
 - 1. Building Storm Drain: 1 percent downward in direction of flow for piping **NPS 3** and smaller; 1 percent downward in direction of flow for piping **NPS 4** and larger.

- 2. Horizontal Storm-Drainage Piping: 1 percent downward in direction of flow.
- N. Install cast-iron soil piping according to CISPI's "Cast Iron Soil Pipe and Fittings Handbook," Chapter IV, "Installation of Cast Iron Soil Pipe and Fittings."
 - 1. Install encasement on underground piping according to ASTM A 674 or AWWA C105.
- O. Install underground PVC piping according to ASTM D 2321.
- P. Install underground, ductile-iron, force-main piping according to AWWA C600. Install buried piping inside building between wall and floor penetrations and connection to storm sewer piping outside building with restrained joints. Anchor pipe to wall or floor. Install thrust-block supports at vertical and horizontal offsets.
- Q. Install underground, copper, force-main tubing according to CDA's "Copper Tube Handbook."
 - 1. Install encasement on piping according to ASTM A 674 or AWWA C105.
- R. Install force mains at elevations indicated.
- S. Plumbing Specialties:
 - 1. Install cleanouts at grade and extend to where building storm drains connect to building storm sewers in storm drainage gravity-flow piping. Install cleanout fitting with closure plug inside the building in storm drainage force-main piping. Comply with requirements for cleanouts specified in Division 22 Section "Storm Drainage Piping Specialties."
 - 2. Install drains in storm drainage gravity-flow piping. Comply with requirements for drains specified in Division 22 Section "Storm Drainage Piping Specialties."
- T. Do not enclose, cover, or put piping into operation until it is inspected and approved by authorities having jurisdiction.
- U. Install sleeves for piping penetrations of walls, ceilings, and floors. Comply with requirements for sleeves specified in Division 22 Section "Sleeves and Sleeve Seals for Plumbing Piping."
- V. Install sleeve seals for piping penetrations of concrete walls and slabs. Comply with requirements for sleeve seals specified in Division 22 Section "Sleeves and Sleeve Seals for Plumbing Piping."
- W. Install escutcheons for piping penetrations of walls, ceilings, and floors. Comply with requirements for escutcheons specified in Division 22 Section "Escutcheons for Plumbing Piping."

59.3 JOINT CONSTRUCTION

- A. Hub-and-Spigot, Cast-Iron Soil Piping Gasketed Joints: Join according to CISPI's "Cast Iron Soil Pipe and Fittings Handbook" for compression joints.

- B. Hub-and-Spigot, Cast-Iron Soil Piping Calked Joints: Join according to CISPI's "Cast Iron Soil Pipe and Fittings Handbook" for lead-and-oakum calked joints.
- C. Hubless, Cast-Iron Soil Piping Coupled Joints: Join according to CISPI 310 and CISPI's "Cast Iron Soil Pipe and Fittings Handbook" for hubless-piping coupling joints.
- D. Threaded Joints: Thread pipe with tapered pipe threads according to ASME B1.20.1. Cut threads full and clean using sharp dies. Ream threaded pipe ends to remove burrs and restore full ID. Join pipe fittings and valves as follows:
 - 1. Apply appropriate tape or thread compound to external pipe threads unless dry seal threading is specified.
 - 2. Damaged Threads: Do not use pipe or pipe fittings with threads that are corroded or damaged. Do not use pipe sections that have cracked or open welds.
- E. Flanged Joints: Align bolt holes. Select appropriate gasket material, size, type, and thickness. Install gasket concentrically positioned. Use suitable lubricants on bolt threads. Torque bolts in cross pattern.
- F. Plastic, Nonpressure-Piping, Solvent-Cemented Joints: Clean and dry joining surfaces. Join pipe and fittings according to the following:
 - 1. Comply with ASTM F 402 for safe-handling practice of cleaners, primers, and solvent cements.
 - 2. ABS Piping: Join according to ASTM D 2235 and ASTM D 2661 Appendixes.
 - 3. PVC Piping: Join according to ASTM D 2855 and ASTM D 2665 Appendixes.

59.4 SPECIALTY PIPE FITTING INSTALLATION

- A. Transition Couplings:
 - 1. Install transition couplings at joints of piping with small differences in OD's.
 - 2. In Drainage Piping: Shielded, nonpressure transition couplings.
 - 3. In Aboveground Force-Main Piping: Fitting-type transition couplings.
 - 4. In Underground Force-Main Piping:
 - a. **NPS 1-1/2** and Smaller: Fitting-type transition couplings.
 - b. **NPS 2** and Larger: Pressure transition couplings.
- B. Dielectric Fittings:
 - 1. Install dielectric fittings in piping at connections of dissimilar metal piping and tubing.
 - 2. Dielectric Fittings for **NPS 2** and Smaller: Use dielectric nipples.
 - 3. Dielectric Fittings for **NPS 2-1/2 to NPS 4**: Use dielectric flange kits.
 - 4. Dielectric Fittings for **NPS 5** and Larger: Use dielectric flange kits.

59.5 VALVE INSTALLATION

- A. General valve installation requirements are specified in Division 22 Section "General-Duty Valves for Plumbing Piping."
- B. Shutoff Valves: Install shutoff valve on each sump pump discharge.

1. Install gate or full-port ball valve for piping **NPS 2** and smaller.
 2. Install gate valve for piping **NPS 2-1/2** and larger.
- C. Check Valves: Install swing-check valve, between pump and shutoff valve, on each sump pump discharge.
- D. Backwater Valves: Install backwater valves in piping subject to backflow.
1. Horizontal Piping: Horizontal backwater valves. Use normally closed type unless otherwise indicated.
 2. Install backwater valves in accessible locations.
 3. Comply with requirements for backwater valves specified in Division 22 Section "Storm Drainage Piping Specialties."

59.6 HANGER AND SUPPORT INSTALLATION

- A. Comply with requirements for seismic-restraint devices specified in Division 22 Section "Vibration and Seismic Controls for Plumbing Piping and Equipment."
- B. Comply with requirements for pipe hanger and support devices and installation specified in Division 22 Section "Hangers and Supports for Plumbing Piping and Equipment."
1. Install carbon-steel pipe hangers for horizontal piping in noncorrosive environments.
 2. Install stainless-steel pipe hangers for horizontal piping in corrosive environments.
 3. Install carbon-steel pipe support clamps for vertical piping in noncorrosive environments.
 4. Install stainless-steel pipe support clamps for vertical piping in corrosive environments.
 5. Vertical Piping: MSS Type 8 or Type 42, clamps.
 6. Individual, Straight, Horizontal Piping Runs:
 - a. **100 Feet** and Less: MSS Type 1, adjustable, steel clevis hangers.
 - b. Longer Than **100 Feet**: MSS Type 43, adjustable roller hangers.
 - c. Longer Than **100 Feet** if Indicated: MSS Type 49, spring cushion rolls.
 7. Multiple, Straight, Horizontal Piping Runs **100 Feet** or Longer: MSS Type 44, pipe rolls. Support pipe rolls on trapeze.
 8. Base of Vertical Piping: MSS Type 52, spring hangers.
- C. Support horizontal piping and tubing within **12 inches** of each fitting, valve, and coupling.
- D. Support vertical piping and tubing at base and at each floor.
- E. Rod diameter may be reduced one size for double-rod hangers, with **3/8-inch** minimum rods.
- F. Install hangers for cast-iron soil piping with the following maximum horizontal spacing and minimum rod diameters:
1. **NPS 1-1/2 and NPS 2**: **60 inches** with **3/8-inch** rod.
 2. **NPS 3**: **60 inches** with **1/2-inch** rod.
 3. **NPS 4 and NPS 5**: **60 inches** with **5/8-inch** rod.
 4. **NPS 6 and NPS 8**: **60 inches** with **3/4-inch** rod.

5. NPS 10 and NPS 12: 60 inches with 7/8-inch rod.
6. Spacing for 10-foot pipe lengths may be increased to 10 feet. Spacing for fittings is limited to 60 inches.

G. Install supports for vertical cast-iron soil piping every 15 feet.

H. Manufacturer's written instructions.

59.7 CONNECTIONS

A. Drawings indicate general arrangement of piping, fittings, and specialties.

B. Connect interior storm drainage piping to exterior storm drainage piping. Use transition fitting to join dissimilar piping materials.

C. Connect storm drainage piping to roof drains and storm drainage specialties.

1. Install test tees (wall cleanouts) in conductors near floor, and floor cleanouts with cover flush with floor.
2. Install horizontal backwater valves with cleanout cover flush with floor or in pit with pit cover flush with floor.
3. Comply with requirements for backwater valves cleanouts and drains specified in Division 22 Section "Storm Drainage Piping Specialties."

D. Connect force-main piping to the following:

1. Storm Sewer: To exterior force main.
2. Sump Pumps: To sump pump discharge.

E. Where installing piping adjacent to equipment, allow space for service and maintenance of equipment.

F. Make connections according to the following unless otherwise indicated:

1. Install unions, in piping NPS 2 and smaller, adjacent to each valve and at final connection to each piece of equipment.
2. Install flanges, in piping NPS 2-1/2 and larger, adjacent to flanged valves and at final connection to each piece of equipment.

59.8 IDENTIFICATION

A. Identify exposed storm drainage piping. Comply with requirements for identification specified in Division 22 Section "Identification for Plumbing Piping and Equipment."

59.9 FIELD QUALITY CONTROL

A. During installation, notify authorities having jurisdiction at least 24 hours before inspection must be made. Perform tests specified below in presence of authorities having jurisdiction.

1. Roughing-in Inspection: Arrange for inspection of piping before concealing or closing-in after roughing-in.

2. Final Inspection: Arrange for final inspection by authorities having jurisdiction to observe tests specified below and to ensure compliance with requirements.
- B. Reinspection: If authorities having jurisdiction find that piping will not pass test or inspection, make required corrections and arrange for reinspection.
 - C. Reports: Prepare inspection reports and have them signed by authorities having jurisdiction.
 - D. Test storm drainage piping according to procedures of authorities having jurisdiction or, in absence of published procedures, as follows:
 1. Test for leaks and defects in new piping and parts of existing piping that have been altered, extended, or repaired. If testing is performed in segments, submit separate report for each test, complete with diagram of portion of piping tested.
 2. Leave uncovered and unconcealed new, altered, extended, or replaced storm drainage piping until it has been tested and approved. Expose work that was covered or concealed before it was tested.
 3. Test Procedure: Test storm drainage piping on completion of roughing-in. Close openings in piping system and fill with water to point of overflow, but not less than **10-foot head of water**. From 15 minutes before inspection starts until completion of inspection, water level must not drop. Inspect joints for leaks.
 4. Repair leaks and defects with new materials and retest piping, or portion thereof, until satisfactory results are obtained.
 5. Prepare reports for tests and required corrective action.
 - E. Test force-main piping according to procedures of authorities having jurisdiction or, in absence of published procedures, as follows:
 1. Leave uncovered and unconcealed new, altered, extended, or replaced force-main piping until it has been tested and approved. Expose work that was covered or concealed before it was tested.
 2. Cap and subject piping to static-water pressure of **50 psig** above operating pressure, without exceeding pressure rating of piping system materials. Isolate test source and allow to stand for four hours. Leaks and loss in test pressure constitute defects that must be repaired.
 3. Repair leaks and defects with new materials and retest piping, or portion thereof, until satisfactory results are obtained.
 4. Prepare reports for tests and required corrective action.

59.10 CLEANING

- A. Clean interior of piping. Remove dirt and debris as work progresses.
- B. Protect drains during remainder of construction period to avoid clogging with dirt and debris and to prevent damage from traffic and construction work.
- C. Place plugs in ends of uncompleted piping at end of day and when work stops.

59.11 PIPING SCHEDULE

- A. Flanges and unions may be used on aboveground pressure piping unless otherwise indicated.
- B. Aboveground storm drainage piping **NPS 6** and smaller shall be any of the following:
 - 1. Service class, cast-iron soil pipe and fittings; gaskets; and gasketed joints.
 - 2. Hubless, cast-iron soil pipe and fittings; heavy-duty, hubless-piping couplings; and coupled joints.
 - 3. Dissimilar Pipe-Material Couplings: Shielded, nonpressure transition couplings.
- C. Aboveground, storm drainage piping **NPS 8** and larger shall be any of the following:
 - 1. Service class, cast-iron soil pipe and fittings; gaskets; and gasketed joints.
 - 2. Hubless, cast-iron soil pipe and fittings; CISPI, hubless-piping couplings; and coupled joints.
 - 3. Dissimilar Pipe-Material Couplings: Shielded, nonpressure transition couplings.
- D. Underground storm drainage piping **NPS 6** and smaller shall be any of the following:
 - 1. Service class, cast-iron soil pipe and fittings; gaskets; and gasketed joints.
 - 2. Hubless, cast-iron soil pipe and fittings; heavy-duty, hubless-piping couplings; and coupled joints.
 - 3. Cellular-core PVC pipe, PVC socket fittings, and solvent-cemented joints.
 - 4. Dissimilar Pipe-Material Couplings: Shielded, nonpressure transition couplings.
- E. Underground, storm drainage piping **NPS 8** and larger shall be any of the following:
 - 1. Service class, cast-iron soil pipe and fittings; gaskets; and gasketed joints.
 - 2. Hubless, cast-iron soil pipe and fittings; heavy-duty, hubless-piping couplings; and coupled joints.
 - 3. Cellular-core PVC pipe, PVC socket fittings, and solvent-cemented joints.
 - 4. Cellular-core, sewer and drain series, PVC pipe; PVC socket fittings; and solvent-cemented joints.
 - 5. Dissimilar Pipe-Material Couplings: Shielded, nonpressure transition couplings.
- F. Aboveground storm drainage force mains **NPS 1-1/2** and **NPS 2** shall be any of the following:
 - 1. Hard copper tube, copper pressure fittings, and soldered joints.
 - 2. Galvanized-steel pipe, pressure fittings, and threaded joints.
- G. Aboveground storm drainage force mains **NPS 2-1/2 to NPS 6** shall be any of the following:
 - 1. Hard copper tube, copper pressure fittings, and soldered joints.
 - 2. Galvanized-steel pipe, pressure fittings, and threaded joints.
 - 3. Grooved-end, galvanized-steel pipe; grooved-joint, galvanized-steel-pipe appurtenances; and grooved joints.
 - 4. Fitting-type transition couplings if dissimilar pipe materials.
- H. Underground storm drainage force mains **NPS 4** and smaller shall be any of the following:
 - 1. Hard copper tube; wrought-copper pressure fittings; and soldered joints.

2. Ductile-iron, mechanical-joint piping and mechanical joints.
 3. Ductile-iron, push-on-joint piping and push-on joints.
 4. Ductile-iron, grooved-joint piping and grooved joints.
 5. Fitting-type transition coupling for piping smaller than **NPS 1-1/2** and pressure transition coupling for **NPS 1-1/2** and larger if dissimilar pipe materials.
- I. Underground storm drainage force mains **NPS 5** and larger shall be any of the following:
1. Hard copper tube; wrought-copper pressure fittings; and soldered joints.
 2. Ductile-iron, mechanical-joint piping and mechanical joints.
 3. Ductile-iron, push-on-joint piping and push-on joints.
 4. Ductile-iron, grooved-joint piping and grooved joints.
 5. Pressure transition couplings if dissimilar pipe materials.

END OF SECTION

SECTION 221423 - STORM DRAINAGE PIPING SPECIALTIES

PART 61 - GENERAL

61.1 RELATED DOCUMENTS

- A. Drawings and general provisions of the Contract, including General and Supplementary Conditions and Division 01 Specification Sections, apply to this Section.

61.2 SUMMARY

- A. Section Includes:
 - 1. Roof drains.
 - 2. Miscellaneous storm drainage piping specialties.
 - 3. Cleanouts.
 - 4. Through-penetration firestop assemblies.
 - 5. Flashing materials.

61.3 SUBMITTALS

- A. Product Data: For each type of product indicated.

61.4 QUALITY ASSURANCE

- A. Drainage piping specialties shall bear label, stamp, or other markings of specified testing agency.

PART 62 - PRODUCTS

62.1 METAL ROOF DRAINS

- A. Cast-Iron, Large-Sump, General-Purpose Roof Drains:
 - 1. Manufacturers: Subject to compliance with requirements, provide products by one of the following:
 - a. Josam Company.
 - b. Marathon Roofing Products.
 - c. MIFAB, Inc.
 - d. Smith, Jay R. Mfg. Co.
 - e. Tyler Pipe.
 - f. Watts Water Technologies, Inc.
 - g. Zurn Plumbing Products Group; Specification Drainage Operation.
 - 2. Standard: ASME A112.6.4, for general-purpose roof drains.
 - 3. Body Material: Cast iron.

4. Dimension of Body: Nominal 14-inch (357-mm) diameter.
5. Combination Flashing Ring and Gravel Stop: Required.
6. Flow-Control Weirs: Not required.
7. Outlet: Bottom.
8. Extension Collars: Required.
9. Underdeck Clamp: Required.
10. Expansion Joint: Required.
11. Sump Receiver Plate: Required.
12. Dome Material: Aluminum.
13. Perforated Gravel Guard: Not required.
14. Vandal-Proof Dome: Required.
15. Water Dam: 2 inches (51 mm) high.

B. Metal, Medium-Sump, Promenade Roof Drains:

1. Manufacturers: Subject to compliance with requirements, provide products by one of the following:
 - a. Josam Company.
 - b. MIFAB, Inc.
 - c. Smith, Jay R. Mfg. Co.
 - d. Tyler Pipe.
 - e. Zurn Plumbing Products Group; Specification Drainage Operation.
2. Standard: ASME A112.6.4, for promenade roof drains.
3. Body Material: Cast iron.
4. Dimension of Body: 11- to 12-inch (280- to 305-mm) diameter.
5. Dimension of Frame and Grate: Nominal 12 inches (305 mm) square.
6. Outlet: Bottom.
7. Grate Material: Nickel-bronze alloy.
8. Vandal-Proof Grate: Required.
9. Extension Collars: Required.
10. Underdeck Clamp: Required.
11. Expansion Joint: Required.
12. Sump Receiver Plate: Required.

62.2 MISCELLANEOUS STORM DRAINAGE PIPING SPECIALTIES

A. Downspout Adaptors:

1. Description: Manufactured, gray-iron casting, for attaching to horizontal-outlet, parapet roof drain and to exterior, sheet metal downspout.
2. Size: Inlet size to match parapet drain outlet.

B. Downspout Boots:

1. Description: Manufactured, ASTM A 48/A 48M, gray-iron casting, with strap or ears for attaching to building; NPS 4 (DN 100) outlet; and shop-applied bituminous coating.
2. Size: Inlet size to match downspout and NPS 4 (DN 100) outlet.

C. Conductor Nozzles:

1. Description: Bronze body with threaded inlet and bronze wall flange with mounting holes.
2. Size: Same as connected conductor.

62.3 CLEANOUTS

A. Floor Cleanouts:

1. Manufacturers: Subject to compliance with requirements, provide products by one of the following:
 - a. Josam Company.
 - b. Oatey.
 - c. Sioux Chief Manufacturing Company, Inc.
 - d. Smith, Jay R. Mfg. Co.
 - e. Tyler Pipe.
 - f. Watts Water Technologies, Inc.
 - g. Zurn Plumbing Products Group; Light Commercial Products Operation.
 - h. Zurn Plumbing Products Group; Specification Drainage Operation.
2. Standard: ASME A112.36.2M, for adjustable housing.
3. Size: Same as connected branch.
4. Type: Adjustable housing.
5. Body or Ferrule Material: Cast iron.
6. Clamping Device: Not required.
7. Outlet Connection: Inside call.
8. Closure: Brass plug with straight threads and gasket.
9. Adjustable Housing Material: Cast iron with threads.
10. Frame and Cover Material and Finish: Nickel-bronze, copper alloy.
11. Frame and Cover Shape: Round.
12. Top-Loading Classification: Extra-Heavy Duty.
13. Riser: ASTM A 74, Extra-Heavy class, cast-iron drainage pipe fitting and riser to cleanout.

B. Test Tees:

1. Manufacturers: Subject to compliance with requirements, provide products by one of the following:
 - a. Josam Company.
 - b. MIFAB, Inc.
 - c. Smith, Jay R. Mfg. Co.
 - d. Tyler Pipe.
 - e. Watts Water Technologies, Inc.
 - f. Zurn Plumbing Products Group; Specification Drainage Operation.
2. Standard: ASME A112.36.2M and ASTM A 74, ASTM A 888, or CISPI 301, for cleanout test tees.
3. Size: Same as connected drainage piping.

4. Body Material: Hub-and-spigot, cast-iron soil-pipe T-branch or hubless, cast-iron soil-pipe test tee as required to match connected piping.
5. Closure Plug: Countersunk or raised head.
6. Closure Plug Size: Same as or not more than one size smaller than cleanout size.

C. Wall Cleanouts:

1. Manufacturers: Subject to compliance with requirements, provide products by one of the following:
 - a. Josam Company.
 - b. MIFAB, Inc.
 - c. Smith, Jay R. Mfg. Co.
 - d. Tyler Pipe.
 - e. Watts Water Technologies, Inc.
 - f. Zurn Plumbing Products Group; Specification Drainage Operation.
2. Standard: ASME A112.36.2M, for cleanouts. Include wall access.
3. Size: Same as connected drainage piping.
4. Body Material: Hubless, cast-iron soil-pipe test tee as required to match connected piping.
5. Closure: Countersunk or raised-head plug.
6. Closure Plug Size: Same as or not more than one size smaller than cleanout size.
7. Wall Access: Round, flat, chrome-plated brass or stainless-steel cover plate with screw.
8. Wall Access: Round nickel-bronze wall-installation frame and cover.

62.4 THROUGH-PENETRATION FIRESTOP ASSEMBLIES

A. Through-Penetration Firestop Assemblies:

1. Manufacturers: Subject to compliance with requirements, provide products by one of the following:
 - a. ProSet Systems Inc.
2. Standard: ASTM E 814, for through-penetration firestop assemblies.
3. Certification and Listing: Intertek Testing Service NA for through-penetration firestop assemblies.
4. Size: Same as connected pipe.
5. Sleeve: Molded PVC plastic, of length to match slab thickness and with integral nailing flange on one end for installation in cast-in-place concrete slabs.
6. Stack Fitting: ASTM A 48/A 48M, gray-iron, hubless-pattern, wye branch with neoprene O-ring at base and gray-iron plug in thermal-release harness. Include PVC protective cap for plug.
7. Special Coating: Corrosion resistant on interior of fittings.

62.5 FLASHING MATERIALS

- A. Copper Sheet: ASTM B 152/B 152M, 12 oz./sq. ft. (3.7 kg/sq. m or 0.41-mm thickness).

- B. Zinc-Coated Steel Sheet: ASTM A 653/A 653M, with 0.20 percent copper content and **0.04-inch (1.01-mm)** minimum thickness unless otherwise indicated. Include **G90 (Z275)** hot-dip galvanized, mill-phosphatized finish for painting if indicated.
- C. Elastic Membrane Sheet: ASTM D 4068, flexible, chlorinated polyethylene, **40-mil (1.01-mm)** minimum thickness.
- D. Fasteners: Metal compatible with material and substrate being fastened.
- E. Metal Accessories: Sheet metal strips, clamps, anchoring devices, and similar accessory units required for installation; matching or compatible with material being installed.
- F. Solder: ASTM B 32, lead-free alloy.

PART 63 - EXECUTION

63.1 INSTALLATION

- A. Install roof drains at low points of roof areas according to roof membrane manufacturer's written installation instructions. Roofing materials are specified in Division 07 Sections.
 - 1. Install flashing collar or flange of roof drain to prevent leakage between drain and adjoining roofing. Maintain integrity of waterproof membranes where penetrated.
 - 2. Install expansion joints, if indicated, in roof drain outlets.
 - 3. Position roof drains for easy access and maintenance.
- B. Install downspout adapters on outlet of back-outlet parapet roof drains and connect to sheet metal downspouts.
- C. Install downspout boots at grade with top **12 inches (305 mm)** above grade. Secure to building wall.
- D. Install conductor nozzles at exposed bottom of conductors where they spill onto grade.
- E. Install cleanouts in aboveground piping and building drain piping according to the following instructions unless otherwise indicated:
 - 1. Use cleanouts the same size as drainage piping up to **NPS 4 (DN 100)**. Use **NPS 4 (DN 100)** for larger drainage piping unless larger cleanout is indicated.
 - 2. Locate cleanouts at each change in direction of piping greater than 45 degrees.
 - 3. Locate cleanouts at minimum intervals of **50 feet (15 m)** for piping **NPS 4 (DN 100)** and smaller and **100 feet (30 m)** for larger piping.
 - 4. Locate cleanouts at base of each vertical soil and waste stack.
- F. For floor cleanouts for piping below floors, install cleanout deck plates with top flush with finished floor.
- G. For cleanouts located in concealed piping, install cleanout wall access covers, of types indicated, with frame and cover flush with finished wall.
- H. Install horizontal backwater valves in floor with cover flush with floor.

- I. Install wall cleanouts in vertical conductors. Install access door in wall if indicated.
- J. Install trench drains at low points of surface areas to be drained. Set grates of drains flush with finished surface unless otherwise indicated.
- K. Assemble channel drainage system components according to manufacturer's written instructions. Install on support devices so that top will be flush with adjacent surface.
- L. Install through-penetration firestop assemblies in plastic conductors at concrete floor penetrations.
- M. Install sleeve flashing device with each conductor passing through floors with waterproof membrane.

63.2 CONNECTIONS

- A. Comply with requirements for piping specified in Division 22 Sections. Drawings indicate general arrangement of piping, fittings, and specialties.

63.3 FLASHING INSTALLATION

- A. Fabricate flashing from single piece of metal unless large pans, sumps, or other drainage shapes are required. Join flashing according to the following if required:
 1. Lead Sheets: Burn joints of 6.0-lb/sq. ft. (30-kg/sq. m) lead sheets, 0.0938-inch (2.4-mm) thickness or thicker. Solder joints of 4.0-lb/sq. ft. (20-kg/sq. m) lead sheets, 0.0625-inch (1.6-mm) thickness or thinner.
 2. Copper Sheets: Solder joints of copper sheets.
- B. Install sheet flashing on pipes, sleeves, and specialties passing through or embedded in floors and roofs with waterproof membrane.
 1. Pipe Flashing: Sleeve type, matching the pipe size, with a minimum length of 10 inches (250 mm) and with skirt or flange extending at least 8 inches (200 mm) around pipe.
 2. Sleeve Flashing: Flat sheet, with skirt or flange extending at least 8 inches (200 mm) around sleeve.
 3. Embedded Specialty Flashing: Flat sheet, with skirt or flange extending at least 8 inches (200 mm) around specialty.
- C. Set flashing on floors and roofs in solid coating of bituminous cement.
- D. Secure flashing into sleeve and specialty clamping ring or device.
- E. Fabricate and install flashing and pans, sumps, and other drainage shapes.

63.4 PROTECTION

- A. Protect drains during remainder of construction period to avoid clogging with dirt or debris and to prevent damage from traffic or construction work.

- B. Place plugs in ends of uncompleted piping at end of each day or when work stops.

END OF SECTION

SECTION 223300 - ELECTRIC, DOMESTIC-WATER HEATERS

PART 65 - GENERAL

65.1 RELATED DOCUMENTS

- A. Drawings and general provisions of the Contract, including General and Supplementary Conditions and Division 01 Specification Sections, apply to this Section.

65.2 SUMMARY

- A. Section Includes:
 - 1. Commercial, electric, storage, domestic-water heaters.
 - 2. Domestic-water heater accessories.

65.3 PERFORMANCE REQUIREMENTS

- A. Seismic Performance: Commercial domestic-water heaters shall withstand the effects of earthquake motions determined according to ASCE/SEI 7.
 - 1. The term "withstand" means "the unit will remain in place without separation of any parts from the device when subjected to the seismic forces specified."

65.4 SUBMITTALS

- A. Product Data: For each type and size of domestic-water heater indicated. Include rated capacities, operating characteristics, electrical characteristics, and furnished specialties and accessories.
- B. LEED Submittal:
 - 1. Product Data for Prerequisite EA 2: Documentation indicating that units comply with ASHRAE/IESNA 90.1, Section 7, "Service Water Heating."
- C. Shop Drawings:
 - 1. Wiring Diagrams: For power, signal, and control wiring.
- D. Seismic Qualification Certificates: For commercial domestic-water heaters, accessories, and components, from manufacturer.
 - 1. Basis for Certification: Indicate whether withstand certification is based on actual test of assembled components or on calculation.
 - 2. Dimensioned Outline Drawings of Equipment Unit: Identify center of gravity and locate and describe mounting and anchorage provisions.
 - 3. Detailed description of equipment anchorage devices on which the certification is based and their installation requirements.

- E. Product Certificates: For each type of commercial, electric, domestic-water heater, from manufacturer.
- F. Domestic-Water Heater Labeling: Certified and labeled by testing agency acceptable to authorities having jurisdiction.
- G. Source quality-control reports.
- H. Field quality-control reports.
- I. Operation and Maintenance Data: For electric, domestic-water heaters to include in emergency, operation, and maintenance manuals.
- J. Warranty: Sample of special warranty.

65.5 QUALITY ASSURANCE

- A. Electrical Components, Devices, and Accessories: Listed and labeled as defined in NFPA 70, by a qualified testing agency, and marked for intended location and application.
- B. ASHRAE/IESNA 90.1 Compliance: Applicable requirements in ASHRAE/IESNA 90.1.
- C. ASME Compliance: Where ASME-code construction is indicated, fabricate and label commercial, domestic-water heater storage tanks to comply with ASME Boiler and Pressure Vessel Code: Section VIII, Division 1.
- D. NSF Compliance: Fabricate and label equipment components that will be in contact with potable water to comply with NSF 61, "Drinking Water System Components - Health Effects."

65.6 COORDINATION

- A. Coordinate sizes and locations of concrete bases with actual equipment provided.

65.7 WARRANTY

- A. Special Warranty: Manufacturer's standard form in which manufacturer agrees to repair or replace components of electric, domestic-water heaters that fail in materials or workmanship within specified warranty period.
 - 1. Failures include, but are not limited to, the following:
 - a. Structural failures including storage tank and supports.
 - b. Faulty operation of controls.
 - c. Deterioration of metals, metal finishes, and other materials beyond normal use.
 - 2. Warranty Periods: From date of Substantial Completion.
 - a. Commercial, Electric, Domestic-Water Booster Heaters:
 - 1) Controls and Other Components: Three years.

- b. Commercial, Electric, Storage, Domestic-Water Heaters:
 - 1) Storage Tank: Three years.
 - 2) Controls and Other Components: Three years.
- c. Compression Tanks: Five years.

PART 66 - PRODUCTS

66.1 COMMERCIAL, ELECTRIC, DOMESTIC-WATER HEATERS

A. Commercial, Electric, Storage, Domestic-Water Heaters:

1. Manufacturers: Subject to compliance with requirements, provide products by one of the following:
 - a. American Water Heaters.
 - b. Bradford White Corporation.
 - c. Cemline Corporation.
 - d. Electric Heater Company (The).
 - e. GSW Water Heating.
 - f. HESco Industries, Inc.
 - g. Lochinvar Corporation.
 - h. Precision Boilers, Inc.
 - i. PVI Industries, LLC.
 - j. RECO USA.
 - k. Rheem Manufacturing Company.
 - l. Smith, A. O. Water Products Co.; a division of A. O. Smith Corporation.
2. Standard: UL 1453.
3. Storage-Tank Construction: ASME-code, steel vertical arrangement.
 - a. Tappings: Factory fabricated of materials compatible with tank and piping connections. Attach tappings to tank before testing.
 - 1) **NPS 2** and Smaller: Threaded ends according to ASME B1.20.1.
 - 2) **NPS 2-1/2** and Larger: Flanged ends according to ASME B16.5 for steel and stainless-steel flanges, and according to ASME B16.24 for copper and copper-alloy flanges.
 - b. Pressure Rating: **150 psig**.
 - c. Interior Finish: Comply with NSF 61 barrier materials for potable-water tank linings, including extending lining material into tappings.
4. Factory-Installed Storage-Tank Appurtenances:
 - a. Anode Rod: Replaceable magnesium.
 - b. Drain Valve: Corrosion-resistant metal complying with ASSE 1005.
 - c. Insulation: Comply with ASHRAE/IESNA 90.1.
 - d. Jacket: Steel with enameled finish.
 - e. Heating Elements: Electric, screw-in or bolt-on immersion type arranged in multiples of three.
 - f. Temperature Control: Adjustable thermostat.

- g. Safety Controls: High-temperature-limit and low-water cutoff devices or systems.
 - h. Relief Valves: ASME rated and stamped for combination temperature-and-pressure relief valves. Include one or more relief valves with total relieving capacity at least as great as heat input, and include pressure setting less than domestic-water heater working-pressure rating. Select one relief valve with sensing element that extends into storage tank.
5. Special Requirements: NSF 5 construction.

66.2 DOMESTIC-WATER HEATER ACCESSORIES

A. Domestic-Water Compression Tanks:

1. Manufacturers: Subject to compliance with requirements, provide products by one of the following:
 - a. AMTROL Inc.
 - b. Flexcon Industries.
 - c. Honeywell International Inc.
 - d. Pentair Pump Group (The); Myers.
 - e. Smith, A. O. Water Products Co.; a division of A. O. Smith Corporation.
 - f. State Industries.
 - g. Taco, Inc.
 2. Description: Steel pressure-rated tank constructed with welded joints and factory-installed butyl-rubber diaphragm. Include air precharge to minimum system-operating pressure at tank.
 3. Construction:
 - a. Tappings: Factory-fabricated steel, welded to tank before testing and labeling. Include ASME B1.20.1 pipe thread.
 - b. Interior Finish: Comply with NSF 61 barrier materials for potable-water tank linings, including extending finish into and through tank fittings and outlets.
 - c. Air-Charging Valve: Factory installed.
 4. Capacity and Characteristics:
 - a. See Schedule on Sheet P0.2.
- B. Drain Pans: Corrosion-resistant metal with raised edge. Comply with ANSI/CSA LC 3. Include dimensions not less than base of domestic-water heater, and include drain outlet not less than **NPS 3/4** with ASME B1.20.1 pipe threads or with ASME B1.20.7 garden-hose threads.
- C. Piping-Type Heat Traps: Field-fabricated piping arrangement according to ASHRAE/IESNA 90. or ASHRAE 90.2.
- D. Heat-Trap Fittings: ASHRAE 90.2.
- E. Combination Temperature-and-Pressure Relief Valves: ASME rated and stamped. Include relieving capacity at least as great as heat input, and include pressure setting less than

domestic-water heater working-pressure rating. Select relief valves with sensing element that extends into storage tank.

- F. Vacuum Relief Valves: ANSI Z21.22/CSA 4.4.
- G. Shock Absorbers: ASSE 1010 or PDI-WH 201, Size A water hammer arrester.
- H. Domestic-Water Heater Mounting Brackets: Manufacturer's factory-fabricated steel bracket for wall mounting, capable of supporting domestic-water heater and water.

66.3 SOURCE QUALITY CONTROL

- A. Factory Tests: Test and inspect domestic-water heaters specified to be ASME-code construction, according to ASME Boiler and Pressure Vessel Code.
- B. Hydrostatically test commercial domestic-water heaters to minimum of one and one-half times pressure rating before shipment.
- C. Electric, domestic-water heaters will be considered defective if they do not pass tests and inspections.
- D. Prepare test and inspection reports.

PART 67 - EXECUTION

67.1 DOMESTIC-WATER HEATER INSTALLATION

- A. Commercial, Electric, Domestic-Water Heater Mounting: Install commercial, electric, domestic-water heaters on concrete base. Comply with requirements for concrete bases specified in Division 03 Section "Cast-in-Place Concrete."
 - 1. Exception: Omit concrete bases for commercial, electric, domestic-water heaters if installation on stand, bracket, suspended platform, or directly on floor is indicated.
 - 2. Maintain manufacturer's recommended clearances.
 - 3. Arrange units so controls and devices that require servicing are accessible.
 - 4. Install dowel rods to connect concrete base to concrete floor. Unless otherwise indicated, install dowel rods on 18-inch (450-mm) centers around the full perimeter of concrete base.
 - 5. For supported equipment, install epoxy-coated anchor bolts that extend through concrete base and anchor into structural concrete floor.
 - 6. Place and secure anchorage devices. Use setting drawings, templates, diagrams, instructions, and directions furnished with items to be embedded.
 - 7. Install anchor bolts to elevations required for proper attachment to supported equipment.
 - 8. Anchor domestic-water heaters to substrate.
- B. Install electric, domestic-water heaters level and plumb, on 3" high concrete pad according to layout drawings, original design, and referenced standards. Maintain manufacturer's

recommended clearances. Arrange units so controls and devices needing service are accessible.

1. Install shutoff valves on domestic-water-supply piping to domestic-water heaters and on domestic-hot-water outlet piping. Comply with requirements for shutoff valves specified in Division 22 Section "General-Duty Valves for Plumbing Piping."
- C. Install commercial, electric, domestic-water heaters with seismic-restraint devices. Comply with requirements for seismic-restraint devices specified in Division 22 Section "Vibration and Seismic Controls for Plumbing Piping and Equipment."
- D. Install combination temperature-and-pressure relief valves in water piping for electric, domestic-water heaters without storage. Extend commercial-water-heater relief-valve outlet, with drain piping same as domestic-water piping in continuous downward pitch, and discharge by positive air gap onto closest floor sink.
- E. Install water-heater drain piping as indirect waste to spill by positive air gap into open drains or over floor drains. Install hose-end drain valves at low points in water piping for electric, domestic-water heaters that do not have tank drains. Comply with requirements for hose-end drain valves specified in Division 22 Section "Domestic Water Piping Specialties."
- F. Install thermometers on outlet piping of electric, domestic-water heaters. Comply with requirements for thermometers specified in Division 22 Section "Meters and Gages for Plumbing Piping."
- G. Assemble and install inlet and outlet piping manifold kits for multiple electric, domestic-water heaters. Fabricate, modify, or arrange manifolds for balanced water flow through each electric, domestic-water heater. Include shutoff valve and thermometer in each domestic-water heater inlet and outlet, and throttling valve in each electric, domestic-water heater outlet. Comply with requirements for valves specified in Division 22 Section "General-Duty Valves for Plumbing Piping," and comply with requirements for thermometers specified in Division 22 Section "Meters and Gages for Plumbing Piping."
- H. Install piping-type heat traps on inlet and outlet piping of electric, domestic-water heater storage tanks without integral or fitting-type heat traps.
- I. Fill electric, domestic-water heaters with water.
- J. Charge domestic-water compression tanks with air.

67.2 CONNECTIONS

- A. Comply with requirements for piping specified in Division 22 Section "Domestic Water Piping." Drawings indicate general arrangement of piping, fittings, and specialties.
- B. Where installing piping adjacent to electric, domestic-water heaters, allow space for service and maintenance of water heaters. Arrange piping for easy removal of domestic-water heaters.

67.3 IDENTIFICATION

- A. Identify system components. Comply with requirements for identification specified in Division 22 Section "Identification for Plumbing Piping and Equipment."

67.4 FIELD QUALITY CONTROL

- A. Perform tests and inspections.
 - 1. Manufacturer's Field Service: Engage a factory-authorized service representative to inspect components, assemblies, and equipment installations, including connections, and to assist in testing.
 - 2. Leak Test: After installation, charge system and test for leaks. Repair leaks and retest until no leaks exist.
 - 3. Operational Test: After electrical circuitry has been energized, start units to confirm proper operation.
 - 4. Test and adjust controls and safeties. Replace damaged and malfunctioning controls and equipment.
- B. Electric, domestic-water heaters will be considered defective if they do not pass tests and inspections.
- C. Prepare test and inspection reports.

67.5 DEMONSTRATION

- A. Engage a factory-authorized service representative to train Owner's maintenance personnel to adjust, operate, and maintain commercial, electric, domestic-water heaters.

END OF SECTION

SECTION 224600 - SECURITY PLUMBING FIXTURES

PART 69 - GENERAL

69.1 RELATED DOCUMENTS

- A. Drawings and general provisions of the Contract, including General and Supplementary Conditions and Division 01 Specification Sections, apply to this Section.

69.2 SUMMARY

- A. This Section includes the following security plumbing fixtures and related components:
 - 1. Drinking fountains.
 - 2. Lavatories.
 - 3. Utility sink.
 - 4. Kitchen sink.
 - 5. Water closets.
 - 6. Flushometer valves for vitreous-china water closets.
 - 7. Fixture supports for front-mounting, stainless-steel fixtures and vitreous-china, wall-mounting fixtures.
- B. Related Sections include the following:
 - 1. Division 10 Section "Toilet, Bath, and Laundry Accessories."

69.3 DEFINITIONS

- A. Accessible Fixture: Security plumbing fixture that can be approached and used by people with disabilities.
- B. Back-Mounting-Type Fixture: Security plumbing fixture designed to mount on wall sleeve built into wall so installation and removal of fixture and piping and other components are only accessible from service space behind wall.
- C. Front-Mounting-Type Fixture: Security plumbing fixture designed to mount on fixture support with installation and removal from fixture side of wall, and piping and other components are accessible from access panels in fixture or wall.

69.4 SUBMITTALS

- A. Product Data: For each type of product indicated. Include furnished specialties and accessories.
- B. Shop Drawings: Diagram power, signal, and control wiring.
- C. Field quality-control test reports.

- D. Operation and Maintenance Data: For security plumbing fixtures to include in emergency, operation, and maintenance manuals.

69.5 **QUALITY ASSURANCE**

- A. Electrical Components, Devices, and Accessories: Listed and labeled as defined in NFPA 70, Article 100, by a testing agency acceptable to authorities having jurisdiction, and marked for intended use.
- B. Regulatory Requirements: Comply with requirements in ICC A117.1, "Accessible and Usable Buildings and Facilities"; 2016 California Building Code (CBC) Chapter 35; about security plumbing fixtures for people with disabilities. Comply with requirements in "Energy Policy Act" about water flow and consumption rates for plumbing fixtures.
- C. NSF Standard: Comply with NSF 61, "Drinking Water System Components - Health Effects," for fixture materials that will be in contact with potable water.
- D. Select combinations of fixtures and trim, faucets, fittings, and other components that are compatible.

69.6 **EXTRA MATERIALS**

- A. Furnish extra materials described below that match products installed and that are packaged with protective covering for storage and identified with labels describing contents.
 - 1. Flushometer Valves: Equal to 10 percent of amount installed for each type indicated.

PART 70 - PRODUCTS

70.1 PLUMBING FIXTURES

- A. Plumbing fixtures and accessories provided in a toilet room or bathing room required to comply with CBC Section 11B-213.2 shall comply with CBC Section 11B-213.3.
- B. Effective March 1, 2017, all single-user toilet facilities shall be identified as Gender Neutral facilities by a door symbol that complies with CBC Sections 11B-216.8 and 11B-703.2.6.3. No pictogram, text or braille is required on the symbol. If tactile jamb signage is provided, the signage shall comply with the appropriate technical requirements of CBC Section 11B-703. Examples of appropriate designations are "ALL-GENDER RESTROOM", "RESTROOM" or "UNISEX RESTROOM". DSA BU 17-01.
- C. Accessible plumbing fixtures shall comply with all the requirements in CBC Division 6.
- D. Clearance around accessible water closets and in toilet compartments shall be 60 inches minimum measured perpendicular from the side wall and 56 inches minimum measured perpendicular from the rear wall per CBC Section 11B-604.3.1.
- E. Heights and location of all accessible fixtures shall be mounted according to CBC Sections 11B-602 through 11B-612.

- F. Accessible fixture controls shall comply with CBC Sections 11B-602.3 for drinking fountains, 11B-604.6 for water closets, 11B-604.9.5 for children’s water closets, 11B-605.4 for urinals, 11B-606.4 for lavatories and sinks, 11B-607.5 for bathtubs, 11B-608.5 for showers, and 11B-611.3 for washing machines and clothes dryers.
- G. Accessible lavatories and sinks shall be mounted with the front of the higher rim or counter surface 34” maximum above the finish floor or ground. Depth of lavatories or sinks shall not interfere with knee and toe clearance provided in accordance with CBC Section 11B-306 when a forward approach is required. CBC Sections 11B-606.3 and 11B-606.7.
- H. Water supply and drain pipes under accessible lavatories and sinks shall be insulated or otherwise configured to protect against contact. There shall be no sharp or abrasive surfaces under accessible lavatories and sinks. CBC Section 11B-606.5.

70.2 DRINKING FOUNTAINS

- A. Security Drinking Fountains, DF-1, DF-2 and DF-3. See sheet P0.2, Plumbing Fixture Schedule.

70.3 LAVATORIES

- A. Security Lavatories, L-1. See sheet P0.2, Plumbing Fixture Schedule.

70.4 UTILITY SINKS

- A. Security Service Sinks, S-1. See sheet P0.2, Plumbing Fixture Schedule.

70.5 KITCHEN SINKS

- A. Security Service Sinks, KS-1. See sheet P0.2, Plumbing Fixture Schedule.

70.6 WATER CLOSETS

- A. Security Water Closets, WC-1 and WC-2. See sheet P0.2, Plumbing Fixture Schedule:
 1. Available Manufacturers: Subject to compliance with requirements, manufacturers offering products that may be incorporated into the Work include, but are not limited to, the following:
 2. Manufacturers: Subject to compliance with requirements, provide products by one of the following:

70.7 FIXTURE SUPPORTS

- A. Off-Floor, Plumbing Fixture Supports:
 1. Available Manufacturers: Subject to compliance with requirements, manufacturers offering products that may be incorporated into the Work include, but are not limited to, the following:

2. Manufacturers: Subject to compliance with requirements, provide products by one of the following:
 - a. Josam Company.
 - b. MIFAB, Inc.
 - c. Smith, Jay R. Mfg. Co.
 - d. Tyler Pipe; Wade Div.
 - e. Watts Drainage Products Inc.; a div. of Watts Industries, Inc.
 - f. Zurn Plumbing Products Group; Specification Drainage Operation.

3. Description: ASME A112.6.1M carriers with dimensions and trim matching fixture.
 - a. Stainless-Steel, Front-Mounting Fixtures: With modifications.
 - 1) Drinking Fountains: Type I drinking fountain carrier.
 - 2) Lavatories: Type III lavatory carrier.
 - 3) Water Closets: Combination support and waste fitting assembly.

PART 71 - EXECUTION

71.1 EXAMINATION

- A. Examine roughing-in for water supply and sanitary drainage and vent piping systems to verify actual locations of piping connections before security plumbing fixture installation.
- B. Examine floors and walls for suitable conditions where security plumbing fixtures will be installed.
- C. Proceed with installation only after unsatisfactory conditions have been corrected.

71.2 SECURITY PLUMBING FIXTURE INSTALLATION

- A. Install back-mounting-type, stainless-steel security plumbing fixtures as follows:
 1. Install wall sleeve in wall.
 2. Install fixture on wall sleeve; mount components on or attached to wall sleeve with access from accessible service space.
 3. Extend supply piping from service space to fixture.
 4. Install soil and waste piping from fixture and extend into service space.
 5. Install fixture trap in service space instead of below fixture drain.

- B. Install front-mounting-type, stainless-steel security plumbing fixtures as follows:
 1. Install fixture support or mounting bracket.
 2. Install fixture on support; mount components inside of or attached to fixture.
 3. Extend supply piping from pipe space to fixture.
 4. Install trap below fixture and extend soil and waste piping into pipe space.
 5. Install fixture on support.
 6. Install components in pipe space with access panels.

- C. Install security plumbing fixture outlets with gasket seals.
- D. Install fixtures designated "accessible" according to ICC A117.1 for heights, dimensions, and clearances.
- E. Install fixtures level and plumb.
- F. Install shutoff valves in water-supply piping to fixtures. Use ball, gate, or globe valve if specific type valve is not indicated. Install valves in locations where they can be easily reached for operation. Valves are specified in Division 22 Section "General-Duty Valves for Plumbing Piping."
- G. Install dielectric fittings in water-supply piping to fixtures if piping and fixture connections are made of different metals. See Section 220000 "General Plumbing Requirements" for dielectric fittings.
- H. Install toilet seats on water closets if seats are indicated.

71.3 CONNECTIONS

- A. Piping installation requirements are specified in other Division 22 Sections. Drawings indicate general arrangement of piping, fittings, and specialties.
- B. Connect hot- and cold-water supply piping to security plumbing fixtures. Include supply stops, if specified, or ball valve on each supply. Ball valves are specified in Division 22 Section "General-Duty Valves for Plumbing Piping."
- C. Connect soil and waste piping to security plumbing fixtures.
- D. Ground equipment according to Division 26 Section "Grounding and Bonding for Electrical Systems."
- E. Connect wiring according to Division 26 Section "Low-Voltage Electrical Power Conductors and Cables."

71.4 FIELD QUALITY CONTROL

- A. Perform the following field tests and inspections and prepare test reports:
 1. Testing: After installing security plumbing fixtures and after electrical circuitry has been energized, test for compliance with requirements.
 2. Remove and replace malfunctioning security plumbing fixtures. Retest as specified above after repairs or replacements are made.

71.5 ADJUSTING

- A. Operate and adjust water-supply flushometers and flow-control valves on security plumbing fixtures.

71.6 **CLEANING**

- A. Clean security plumbing fixtures, faucets, and other fittings with manufacturers' recommended cleaning methods and materials. Do the following:
 - 1. Remove faucet spouts and strainers, remove sediment and debris, and reinstall spouts and strainers.
 - 2. Remove sediment and debris from drains.
- B. After completing installation of exposed, factory-finished fixtures, faucets, and fittings, inspect exposed finishes and repair damaged finishes.

71.7 **PROTECTION**

- A. Provide protective covering for installed security plumbing fixtures and fittings.
- B. Do not allow use of security plumbing fixtures for temporary facilities unless approved in writing by Owner.

END OF SECTION

SECTION 230000 - GENERAL MECHANICAL REQUIREMENTS

PART 1 - GENERAL

1.1 GENERAL REQUIREMENTS

- A. The General conditions, supplementary conditions, special Requirements, and applicable portions of Division 1 of the specification are a part of this Division and the requirements contained herein are supplementary to them.
- B. This Division is an integrated whole comprising of interrelated and interdependent sections and shall be considered in its entirety in determining requirements.
- C. Refer to other sections of this Division for additional requirements or information regarding the subjects of this Section.

1.2 ABBREVIATIONS AND DEFINITIONS (as used on Division 23 Drawings and herein)

- A. This Division is abbreviated and includes incomplete sentences. Supply omitted words by inference.
- B. Symbols: "S" means submittals are required; "[M/O]" means Maintenance/Operating data is required; see paragraphs hereinafter.
- C. "Provide" means furnish, install and connect unless otherwise described in specific instances.
- D. "Ductwork" means ducts, plenums, compartments, casings or any like devices, including the building structure, which are used to convey or contain air.
- E. "Extend", "Submit", "Repair", "Abandon", "Replace", "Remove" and similar words mean that the Contractor (or his designated subcontractor) shall accomplish the action described.
- F. "Codes" or "Code" means all codes, laws, statutes, rules, regulations, ordinances, orders, decrees, and other requirements of all legally constructed authorities and public utility franchise holders having jurisdiction.
- G. "Products", "Materials" and "Equipment" are used interchangeably and mean materials, fixtures, equipment, accessories, etc.
- H. "Substantial Mechanical Completion" means all components of all systems are functioning but lacking in final adjustment.

1.3 DESCRIPTION

- A. Provide a complete and operable installation, including all labor, supervision, materials, equipment, tools, apparatus, transportation, warehousing, rigging, scaffolding and other

equipment and services necessary to accomplish the work in accordance with the intent and meaning of these drawings and specifications.

1.4 RELATED WORK

- A. Coordination: Refer to Architectural, Civil, Structural, and Electrical Drawings for the construction details and coordinate the work of this Division with that of other Divisions. Order the work of this Division so that progress will harmonize with that of other Divisions and all work will proceed expeditiously. The work of this Division shall include direct responsibility for the correct placing and connection of mechanical work in relation to the work of other Divisions.
- B. Examine other Divisions for work related to the work of this Division, especially Division 26 - ELECTRICAL.

1.5 EXISTING CONDITIONS

- A. Visit the site prior to bidding and investigate the existing conditions which affect or will be affected by the work of this Division. Become thoroughly familiar with the working conditions and take into account any special or unusual features peculiar to this job. By the act of submitting a Bid, the Contractor will be deemed to have complied with the foregoing, to have accepted such conditions, and to have made allowance therefore in preparing his Bid.
- B. The locations of existing concealed utility lines are shown in accordance with reference data received by the Architect. The Architect does not guarantee the accuracy of such data. The points of connection are therefore approximate and the Bidder shall include adequate funds in his bid to cover costs of connection regardless of their exact location.

1.6 DRAWINGS AND SPECIFICATIONS

- A. Drawings and specifications are intended to complement each other. Where a conflict exists between the requirements of the drawings and/or the specifications, request clarification.
- B. The Architect shall interpret the drawings and the specifications, and his decision as to the true intent and meaning thereof and the quality, quantity, and sufficiency of the materials and workmanship furnished there under shall be accepted as final and conclusive.
- C. In case of conflict not clarified prior to Bidding deadline, use the most costly alternative (better quality, greater quantity, or larger size) in preparing the Bid. A clarification will be issued to the successful bidder as soon as feasible after the Award and if appropriate a deductive change order will be issued.
- D. All provisions shall be deemed mandatory except as expressly indicated as optional by the word "may" or "option".

1.7 PERMITS AND INSPECTIONS

- A. Obtain, schedule and pay for permits, licenses, approvals, tests, and inspections required by legally constituted authorities and public utility franchise holders having jurisdiction over the work.
- B. Afford the Architect's representative every facility for evaluating the skill and competence of the mechanics and to examine the materials. Concealed work shall be reopened when so directed during his periodic visits.

1.8 CODES AND REGULATIONS

- A. By submitting a bid, Contractor is deemed to represent himself as competent to accomplish the work of this Division in conformance with applicable Codes. In case of conflict between the Contract documents and the Code requirements, the Codes shall take precedence. Should such conflicts appear, cease work on the parts of the contract affected and immediately notify the Architect in writing. It shall be the Contractor's responsibility to correct, at no cost to the Owner, any work he executes in violation of Code requirements. Specify references to codes elsewhere in this Division are either to aid the Contractor in locating applicable information or to deny him permission to use options which are permitted by Codes.
- B. Applicable Codes: (Current editions unless otherwise noted)
 - 1. All local codes; city and/or County as applicable
 - 2. OSHA requirements
 - 3. Uniform Building Code
 - 4. Uniform Mechanical Code
 - 5. Uniform Plumbing Code
 - 6. California Code of Regulations (CCR) Titles
 - 7. Fire Marshal Regulations
 - 8. Regulations of all other authorities having jurisdiction.
- C. Where conflict or variation exists among codes, the most stringent shall govern.
- D. Certificates of Conformance or Compliance: Submit original and not pre-printed certifications. Do not make statements in the certifications that could be interpreted to imply that the product does not meet all requirements specified, such as "as good as", "achieve the same end use and results as materials formulated in accordance with the referenced publications", "equal or exceed the services and performance of the specified material". Simply state that the product conforms to the requirements specified.
- E. Certified Test Reports: Certified Test Reports are reports of tests conducted on previously manufactured materials or equipment identical to that proposed for use. Before delivery of materials and equipment, submit certified copies of test reports specified in the individual sections.

- F. Factory Tests: Factory tests are tests which are required to be performed on the actual materials or equipment proposed for use. Submit results of the tests in accordance with the requirements for laboratory test results of this Contract.
- G. Permits and Certificates of Inspection: Furnish the originals.
- H. Testing procedures and test results required in this and other sections. Furnish 2 copies.
- I. Other data required by other sections of this Division. Furnish 2 copies.

1.9 RECORD AND DOCUMENTATION

A. Accumulate the following and deliver to the Owner's representative prior to final acceptance of the work:

1. Record (As-Built) Drawings:

- a. Maintain in good order in the field office a complete set of prints for all work being done under Division 23. Update the drawings daily with neat and legible annotations in red ink showing the work as actually installed.
- b. The actual size, location and elevation of all buried lines, valve boxes, manholes, monuments, and stub-outs shall be accurately located and dimensioned from building walls or other permanent landmarks.
- c. Furnish the originals.

2. Operation and Maintenance Manual: Furnish an operation and maintenance manual covering the stipulated mechanical systems and equipment. Seven copies of the manual, bound in hardback binders or an approved equivalent, shall be provided to the Architect in accordance with the Division 1 section on Maintenance and Operation Manuals. Furnish one complete manual prior to the time that system or equipment tests are performed. Furnish the remaining manuals before the contract is completed. The following identification shall be inscribed on the cover:

OPERATION AND MAINTENANCE MANUAL

PROJECT TITLE.....

CONTRACTOR.....

Provide a table of contents. Insert tab sheets to identify discrete subjects. Instruction sheets shall be legible and easily understood, with large sheets of drawings folded in. The manual shall be complete in all respects for all materials, piping, valves, devices and equipment, controls, accessories and appurtenances stipulated. Include as a minimum the following:

- a. Updated approved materials list, shop drawings and catalog information of all items indicated by symbol "M/O" at titles or beginning of paragraphs.
- b. System layout showing piping, valves and controls.
- c. Wiring and control diagrams with data to explain detailed operation and control

of each component.

- d. A control sequence describing start-up, operation and shutdown.
 - e. Detailed description of the function of each principal component of the system.
 - f. Procedure for starting.
 - g. Procedure for operation.
 - h. Shut-down instruction.
 - i. Installation instructions.
 - j. Adjustments, maintenance and overhaul instructions.
 - k. Lubrication schedule including type, grade, temperature range and frequency.
 - l. Safety precautions, diagrams and illustrations.
 - m. Test procedures.
 - n. Performance data.
 - o. Parts lists, with manufacturer's names and catalog numbers.
 - p. Preventive maintenance schedule.
 - q. Service organization with name, address and telephone number.
 - r. Valve identification chart and schedule.
 - s. ASME certification
 - t. Air Balance report.
- B. Standard Compliance: Where equipment or materials are specified to conform with requirements of standards of recognized technical or industrial organizations such as American National Standards (ANSI), American Society of Mechanical Engineers (ASME), American Society of Heating, Refrigeration and Air Conditioning Engineers (ASHRAE), Underwriters Laboratories (UL), American Refrigeration Institute (ARI), American Gas Association (AGA), or National Electrical Manufacturer's Association (NEMA), that use a label or published listing as a method of indicating compliance, proof of such conformance shall be submitted and approved. The label or listing of the specified organization will be acceptable evidence.
- C. Certificates of Conformance or Compliance: Submit original and not pre-printed certifications. Do not make statements in the certifications that could be interpreted to imply that the product does not meet all requirements specified, such as "as good as", "achieve the same end use and results as materials formulated in accordance with the referenced publications", "equal or exceed the services and performance of the specified material". Simply state that the product conforms to the requirements specified.
- D. Certified Test Reports: Certified Test Reports are reports of tests conducted on previously manufactured materials or equipment identical to that proposed for use. Before delivery of materials and equipment, submit certified copies of test reports specified in the individual

sections.

- E. Factory Tests: Factory tests are tests which are required to be performed on the actual materials or equipment proposed for use. Submit results of the tests in accordance with the requirements for laboratory test results of this Contract.
- F. Permits and Certificates of Inspection: Furnish the originals.
- G. Testing procedures and test results required in this and other sections. Furnish 2 copies.
- H. Other data required by other sections of this Division. Furnish 2 copies.

1.10 TOOLS

- A. Provide all special tools needed for proper operation and routine adjustment and maintenance of systems and equipment. Deliver tools to Owner's representative and request a receipt for same.

1.11 CONSTRUCTION COST BREAKDOWN

- A. To assist the Architect and Engineer in evaluation of the construction cost, the Contractor shall prepare and submit for review a construction cost breakdown for the major subdivisions of the mechanical work.
- B. Subdivide each item on the breakdown into two headings: labor and materials. Include overhead and profit in each entry.
- C. Cost breakdowns shall be submitted and approved prior to the first payment request. Send one copy of the breakdown directly to the Engineer and the remaining copies sent through regular channels.

PART 2 - PRODUCTS

2.1 MATERIALS AND EQUIPMENT

- A. Standard Products: Materials and equipment shall be essentially the standard cataloged products of manufacturers regularly engaged in production of such materials or equipment and shall be their latest standard designs that comply with the specification requirements. Materials and equipment shall duplicate items that have been in satisfactory commercial or industrial use at least two years prior to bid opening. Where two or more units of the same type of equipment are required, these units shall be products of a single manufacturer. The components thereof, however, are not required to be exclusively of the same manufacturer. Each major component of equipment shall have manufacturer's name, address, model, and serial number on a nameplate securely affixed in a conspicuous place. The nameplate of the distributing agent will not be acceptable.
- B. Whenever on the plans, or in these specifications, products are identified by the name of

one manufacturer, it is intended that equivalent products of other manufacturers are acceptable, unless otherwise indicated, if accepted as a substitution by the Architect. Where three or more manufacturers are listed as "acceptable manufacturers" however, then the products furnished shall be the product of one of the manufacturers listed. Manufacturers listed as "acceptable manufacturers" shall meet quality and performance of a particular one specified by both name and catalog number.

2.2 SUBSTITUTIONS

- A. General: Should the Contractor desire to substitute for specified products, he shall submit with the Material List a complete list of the requested substitutions. The request shall contain complete descriptive information of the products. Samples for evaluation shall also be submitted upon the Architect's request. If in the Architect's opinion the products as presented in this first submittal are in variance with the specified products, or if the information submitted is not sufficiently complete to allow proper evaluation, the substitution will be disallowed from consideration and the specified products shall be furnished. By proposing a substitution, it is deemed that the Contractor shall bear the cost of any changes (whether architectural, structural, electrical or mechanical) necessary to accommodate the substitution.
- B. Specific: Refer to other sections of this Division for additional requirements.

2.3 SUBMITTALS

- A. General:
 - 1. Provide for all items indicated with the symbol "[S]" at titles or beginning of paragraphs in accordance with General Provisions covering submittals and as herein specified. Where warranty of longer than one year is specified, include such warranty with submittal. Architect's review of the submittal is only for general conformance with design compliance with the information given in the contract documents. The submittal procedure is required as an effort to minimize the problems which occur due to the discovery of Contractor non-compliance at the construction site. The Contractor is responsible for conformation and correlation of the dimensions, quantities and sizes, for information that pertains to fabrication methods or construction techniques, and for coordination of work of all Divisions of the work. Deviations, if any, from Contract documents shall be clearly and completely indicated (by a separate letter if deviations are extensive) in the submittals, and the lack of such is deemed complete compliance with Contract Documents without any deviations. Submittals favorably processed will not relieve the Contractor of responsibility for deviations not so reported nor for errors in the submittal.
 - 2. In addition to the above, upon permission to proceed after review of submittal and prior to the installation of work, submit dimensioned and scaled drawings (not less than 1/4-inch equal to one foot) of all mechanical equipment rooms and areas. Such layouts shall indicate, but not be limited to, all mechanical equipment, control panels,

pipng, housekeeping pads, ductwork, tube pull, access and maintenance clearances, and other like items. The layout shall also indicate major equipment to be provided under other Sections of work.

3. Contractor Stamp: All submittals shall be stamped with the following text and signed by the Contractors representative:

"IT IS HEREBY CERTIFIED THAT THE PRODUCTS SHOWN AND MARKED IN THIS SUBMITTAL ARE IN COMPLIANCE WITH THE CONTRACT DOCUMENTS AND CAN BE INSTALLED IN THE ALLOCATED SPACES EXCEPT WHERE NOTED AS DEVIATIONS.

CERTIFIED BY:----- DATE:-----

4. All submittals shall be complete and with catalog data and information properly marked to show, among other things, equality of material (where substitution is allowed and desired), adequacy in capacity and performance to meet minimum capacities of performance as specified or indicated. Arrange the submittals in the same sequence as these specifications, and reference (at the upper right-hand corner) the particular specification provision for which each submittal is intended. Incomplete submittals will be rejected.
 5. For all work under Division 23, the notations by the Contractor or Supplier on submittal documents "Per Plans and Specifications", or "As Specified", or similar wording or phrasing is not acceptable and will be cause of rejection. Complete descriptive submittals are required for all Division 23 work.
 6. Refer to the other sections of this Division for specific requirements.
- B. Material List: Within 15 days after award of Contract, submit for approval a complete list of materials proposed for use. Furnish names and addresses of manufacturers, catalog numbers (where applicable) types and trade names. For purposes of uniformity, only one manufacturer will be accepted for each class or type of material. This list is in addition to Shop Drawings.
 - C. Shop Drawings: Submit shop drawings with such promptness as to cause no delay in the work. Do not commence fabrication of the equipment until the approved drawings are received from the Owner's representative.
 - D. Other Submittals: As required by other sections of this Division.

PART 3 - EXECUTION

3.1 WORKMANSHIP AND INSTALLATION METHODS

- A. Workmanship shall be in the best standard practice of the trade.

- B. Execute the work so as to contribute to ease of operation and maintenance, maximum accessibility and best appearance. Execute it so that the installation will conform and adjust itself to the building structure, its equipment and its usage. The work shall be symmetrical, plumb, uniform, properly aligned, and firmly secured in place.
- C. Install equipment in accordance with the manufacturer's instructions and recommendations unless otherwise noted or specified.

3.2 TESTS

A. General:

1. Demonstrate that all components of the work of this Division have been provided and that they operate in accordance with the Contract Documents.
2. Provide instruments and personnel for tests and demonstrations. Submit signed test results.

- B. Specific: Refer to the other sections of this Division for test requirements.

3.3 DELIVERY, HANDLING, STORAGE OF MATERIALS AND PROTECTION OF WORK

- A. Protect materials against dirt, water, chemical and mechanical damage both while in storage and during construction.
- B. Cover materials in such a manner that no finished surfaces will be damaged, marred or splattered with plaster or paint and all moving parts will be kept clean and dry.
- C. Replace or refinish any damaged materials including fronts of control panels, ductwork fittings, and shop fabricated ductwork.
- D. Keep cabinets and other openings closed to prevent entry of foreign matter.

3.4 CLEANUP AND HOUSEKEEPING

- A. Cleaning shall be done as the work proceeds. Periodically remove waste and debris to keep the site as clean as is practical.
- B. Leave exposed parts of the mechanical work in a neat, clean and usable condition, with painted surfaces unblemished and plated metal surfaces polished.

3.5 PROJECT CONDITIONS

A. Site Examinations and Conditions:

1. Regard information relative to existing conditions, services and structure as approximate only. Verify dimensions and locations, and be knowledgeable of all working conditions before submitting Bid. Verify pressure, location, size, and

elevation of existing services (to which points of connection are to be made or crossed) as soon as possible and prior to commencement of any new work.

2. Make minor deviations necessary to conform to actual locations and conditions. Submission of Bid presumes proper examination of Site, locations, dimensions and conditions, and no additional cost will be honored for lack of such examinations.
- B. Existing Services: Examine the Contract Drawings and visit the project site to ascertain the extent of the existing services. Where existing equipment/services serving existing structures and/or existing structures to be demolished are to remain in service, reroute, relocate, or extend such existing equipment and/or services to accommodate this project without additional cost.
- C. Interruption of Existing Services: Where it is necessary to reroute existing services or utilities, or to make connections of new work to existing services or utilities, give timely written notice of such intent to the Owner and secure written approval before proceeding. Make all such interruptions at such time as permitted by the Owner. Anticipate such interruptions to be made outside of normal working hours or normal working days; therefore, no additional cost will be permitted for such work. Except in a case of emergency involving life, limb or health, do not operate any existing equipment (including valves). Where such operations are necessary, they shall be performed by the Owner's personnel.
- D. Access and Placement of Work:
1. Check and coordinate for clearance, accessibility and placement of equipment either by going through openings provided or by placing equipment during construction. Ordering of equipment to be shipped disassembled, or disassembly of equipment at Project Site and re-assembly of equipment to accomplish this requirement shall be executed without additional cost. Where provided openings are inadequate to accommodate equipment, provide new openings and restoration of same, all at no additional cost. Obtain written approval for new openings before proceeding.
 2. Verify location of all plumbing fixtures and equipment within finished spaces with the Architectural Drawings. In the event that Mechanical Drawings do not indicate exact locations, or are in conflict with the Architectural Drawings, obtain information regarding proper locations. Installation of work without proper instruction under such circumstances will result in relocation of work, when directed, without additional cost.
- E. Verification and Coordination: Drawings indicating suggested distribution routes are diagrammatic only, and all scaled and figured dimensions are approximate and are indicated for estimating purposes only. The Drawings do not indicate necessary offsets and like items. Do not construe Contract Drawings as fabrication drawings. Prior to fabrication and installation of work, verify all dimensions, sizes and distribution routes with actual conditions, and prepare submittal and fabrication drawings. Coordinate to avoid possible conflicts and resolve same where such exist. Install work to conform to structure, avoid obstruction, preserve headroom, and keep openings and passageway clear. Changes necessary, resulting from such verification and coordination, shall not be a cause for

additional cost.

- F. See Drawings for extent of demolition.

3.6 WARRANTY

- A. Guarantee, in writing, all work against fault of any product or workmanship for a period of not less than one year after formal acceptance by the Owner; except, where longer periods are specified in the Specifications, such longer periods shall govern. However, when any component fails at any time during this period, the warranty period for such component and all other components that are inactive because of said failure shall be suspended. The warranty period for such component shall resume running for the remaining portion of the warranty period when failed component is completely repaired and in operation; however, in no case shall the resumed portion of the warranty period be less than 3 months in duration.
- B. Neither payments for work, nor total or partial occupancy of work by the Owner, within or prior to the warranty period specified, shall be construed as acceptance of faulty work or shall condone any negligence or omission of Contractor in doing the work.

3.7 SAFETY REQUIREMENTS

- A. Enclose and guard belts, pulleys, chains, gears, couplings, projecting setscrews, keys and other rotating parts in accordance with the OSHA 1910.219. Insulate, guard, and cover any high-temperature equipment and piping so located as to endanger personnel or creature a fire hazard.

3.8 MANUFACTURER'S RECOMMENDATIONS

- A. Where installation procedures or any part thereof are required to be in accordance with the recommendations of the manufacturer of the material or equipment being installed, furnish printed copies of these recommendations to the installing Contractor and Architect prior to installation. Do not proceed with the installation of the item until the recommendations are received. Failure to furnish these recommendations can be cause for rejection of the material.

END OF SECTION

SECTION 230500 - BASIC MECHANICAL MATERIALS AND METHODS

PART 1 - GENERAL

1.1 GENERAL REQUIREMENTS

- A. The contract documents shall apply in their entirety to the work specified herein.
- B. Submittals: Submit shop drawings and manufacturer's data on each item marked [S] in accordance with the submittal General Provisions and Section 23 00 00, Basic Mechanical Requirements.
- C. Maintenance and Operation Manuals: Provide manufacturer's maintenance and operation manuals on each item marked [M/O] in accordance with the Greenbook/Whitebook section on maintenance and operation manuals and Section 23 00 00, Basic Mechanical Requirements.

PART 2 - PRODUCTS

2.1 ELECTRICAL MOTORS [S] [M/O]

- A. Provide all motors indicated on drawings necessary for equipment under the Mechanical Work. See electrical drawings for voltage and phase of electrical services.
- B. Motors exposed outdoors: either epoxy encapsulated winding or TEFC enclosure.
- C. Each motor shall have sufficient starting torque to start the apparatus driven.
- D. Provide all motors with junction boxes or terminals boxes and provide adjustable slide rails for all motors with belt drives. All motors shall have a nameplate voltage rating of the specified operating voltage.
- E. Provide overload protection on single phase motors.
- F. Provide with nameplates permanently attached to exterior housing with manufacturer's name and all electrical characteristics specified thereon.
- G. Brake horsepower shall not exceed 90% of rated motor horsepower.

2.2 MOTOR STARTERS [S] [M/O]

- A. See Electrical Drawings for voltage and phase of electrical services.
- B. Starters for motors will be provided under Division 26. Provide to Division 26 the data necessary for motor starter heater sizing for all motors.
- C. Enclosure: NEMA 1 (unless location of starters dictates otherwise) of sufficient size to

contain all accessories specified.

2.3 EQUIPMENT IDENTIFICATION [S]

- A. General: Identify all equipment using brass discs or laminated plastics. Install as specified below in readily visible locations not interfering with insulation or equipment operation.
 - 1. Brass Discs: Provide minimum 0.040-inch in thickness and 2-inches in diameter or square. Top line of each tag shall have 1/4-inch high black filled letters to indicate designation of service. Bottom line shall have 7/16-inch high black filled numbers to indicate equipment or valve number.
 - 2. Laminated Plastic: Provide white on black with engraved black letters. The equipment identifying name and number lettering size shall be a minimum of 1/4-inch in height, nameplate data 3/16-inch in height and the manufacturer's name and location 1/8-inch in height. Provide laminated plastic tags either 2-1/2-inches by 3-1/2-inches or 3-1/2-inches by 5-inches, as required.

2.4 PRIMERS AND PAINTS [S]

- A. All equipment furnished under Division 23, unless otherwise noted, shall be furnished with a factory applied prime coat.
- B. Where field priming or touch-up priming is required, primer shall be as follows for ferrous metal surfaces:
 - 1. Metal Surfaces, Not Galvanized: Latex, corrosion resistant primer suitable for metal surfaces or Epoxy-polyamide, green primer paint, formula 150, type I (QPL).
 - 2. Metal Surfaces, Galvanized: Galvanized repair compound with high zinc dust content; ZRC Cold Galvanizing Compound, or approved equivalent (no known equivalent).
- C. Finish painting of Mechanical equipment furnished under Division 15: See Section 099600 "High-Performance Coatings."
 - 1. Non-metallic surfaces: Latex (Acrylic Emulsion, Exterior Wood and Masonry) Paint.

2.5 SEALANTS, WATERSTOP

- A. Cold applied, pre-formed, plasticized, waterstop sealing compound consisting of blends of refined hydrocarbon resins and plasticizing compounds; Synko-Flex Waterstop and Primer, or approved equivalent (no known equivalent).

2.6 BOLTED MECHANICAL SEALS [S]

- A. Seals shall be modular, bolted, mechanical link type, consisting of interlocking synthetic rubber links shaped to continuously fill the annular space between the pipe and wall opening. Links shall be loosely assembled with bolts to form a continuous rubber belt around the pipe with a pressure plate under each bolt head and nut. Tightening of the bolts

shall cause the rubber sealing elements to expand to form a water-tight seal between the pipe and the sleeve; Thunderline "Link-Seal" Model LS, or approved equivalent.

PART 3 - EXECUTION

3.1 GENERAL

- A. Install products in accordance with product manufacturer's recommendations. After installation of systems and until formal acceptance of systems by the Owner, be responsible for operation and maintenance of systems.

3.2 FORMING, CUTTING, AND PATCHING

- A. Provide Forming, recesses, chases, blocking and grounds necessary for Mechanical Work.
- B. Provide Cutting (including core drilling and saw cutting), patching and repairing existing structures to accommodate the Mechanical Work. Such work shall include voids, holes, and the like resulting from removal of existing or addition of new Mechanical Work. Restoration shall match existing work.
- C. Core drill all holes through existing concrete structures. Before drilling through any structural members, obtain written permissions from the Architect. Before coring, check all proposed hole locations with electronic device to assure clearance of obstruction (i.e., reinforcement bars, piping, conduits, etc.).
- D. Saw cut all existing concrete and masonry openings and slabs.

3.3 ELECTRICAL WORK

- A. Coordinate with Division 26. See Division 26 Contract Documents for voltage and phase of electrical services.
- B. All power wiring and conduits for same serving motors, and where indicated on Division 26 Contract Drawings, to mechanical control panels, separate or equipment mounted, shall be provided under Division 26.
- C. The following shall be provided under Division 23:
 - 1. Pre-wired mechanical control panels.
 - 2. All automatic or temperature control and interlock wiring, regardless of voltage, and conduits for same necessary for proper operation of equipment under Division 23. This includes interlock wiring between motor starter coils, interlocking relays, contactors, mechanical equipment control panels, temperature control devices, and temperature control panels.
 - 3. Power wiring and conduits for same not indicated on the Division 26 Contract Drawings to mechanical control panels (separate or equipment mounted).

- D. Install all wiring under Division 23 in rigid conduit or electrical metallic tubing indoors and in rigid conduit outdoors. All such wiring shall be concealed.

3.4 FLASHING

- A. Flash and counter flash with metal to make waterproof all penetrations through roofs or exterior walls. Roof flashing shall have a minimum 8-inch skirt. The metal flashing and counterflashing shall be the same material as the equipment to which they are attached. Factory-fabricated flashing may be used for piping. Prior to any interior finish work, test the integrity of all flashing with water hose.

3.5 EQUIPMENT INSTALLATION

- A. Install equipment where shown, as indicated, and in accordance with the manufacturer's recommendations for the specific service.
- B. Provide anchor bolts, setting Drawings and templates for setting equipment.
- C. Assure correct alignment of equipment after setting.
- D. Where grouting is necessary, use non-shrink type.
- E. Before bolting any equipment coat threads with an anti-seize and lubricating compound. Do not use powder driven anchors unless written permission has been obtained from the Architect.
- F. Provide all exposed moving or rotating parts of machines with guards in compliance with OSHA requirements. Install all guards in removable sections, if necessary, and with studs and wing nuts for removal of same in maintenance. Make provision for RPM readings on guards covering end of shafts; enclose fan belts at both sides of belts.

3.6 MAINTENANCE AND ACCESS TO EQUIPMENT

- A. Where valves, dampers, control devices, coils, or other like devices (i.e, plumbing P-trap, water hammer arresters, gauges, thermometers) requiring maintenance, checking or readings are inaccessibly concealed in walls or ceilings, and where indicated, provide square or rectangular access doors. Where space permits, doors for ceiling installation shall not be less than 18-inches by 18-inches. Prior to installation, verify all access locations.
- B. Where there are lubrications within equipment, extend such to exterior of equipment.

3.7 REVIEW OF WORK

- A. Do not allow or cause any mechanical work to be covered, concealed or enclosed until such work has been tested and reviewed. Should such work be covered, concealed or enclosed

before being tested and reviewed, such shall be uncovered and thereafter restored at no additional cost.

3.8 EQUIPMENT IDENTIFICATION

- A. Manufacturer's Nameplates: Provide all equipment with manufacturer's nameplates secured to the respective equipment and indicating, but not being limited to, the manufacturer's name, model, size, serial number, capacity and electrical characteristics. Clean, polish and protect all such nameplates with a coat of clear protective finish.
- B. Equipment Tags: Identify all equipment (such as machinery, motor starters, control panels, pushbuttons and other like devices) exposed to view with identification tags. Secure tags to equipment surface. Where size or surface curvature does not permit such, secure with No. 16 brass jack chain.

3.9 PRIMING, PAINTING, AND COATING

- A. Properly clean surfaces to be touched up of rust, dirt, scale, wax and other deleterious materials. Prime surfaces. Touch up with like material all damaged galvanized or factory-primed metal surfaces. Do not prime over manufacturer's nameplates on equipment.
- B. Coat all bare steel parts of piping accessories below grade with coats of coal-tar based bituminous mastic.
- C. Except for factory priming, factory finish painting and otherwise specified under this Article, all field priming (except touch up) and finish painting shall be under other Divisions.
- D. Paint flat black interior surfaces of all concealed unlined galvanized sheet metal ductwork behind air outlets and inlets.
- E. All exposed insulation surfaces in finished areas shall be ready for finish painting; glue size if necessary.

3.10 TESTS AND ADJUSTMENTS

- A. At the completion of the Work, completely adjust all equipment for their proper use and rating.

END OF SECTION

SECTION 230529 - HANGERS AND SUPPORTS FOR HVAC PIPING AND EQUIPMENT

PART 72 - GENERAL

72.1 RELATED DOCUMENTS

- A. Drawings and general provisions of the Contract, including General and Supplementary Conditions and Division 01 Specification Sections, apply to this Section.

72.2 SUMMARY

- A. Section Includes:
 - 1. Equipment supports.
- B. Related Sections:
 - 1. Division 23 Section(s) "Metal Ducts" for duct hangers and supports.

72.3 PERFORMANCE REQUIREMENTS

- A. Structural Performance: Hangers and supports for HVAC piping and equipment shall withstand the effects of gravity loads and stresses within limits and under conditions indicated according to ASCE/SEI 7.
 - 1. Design equipment supports capable of supporting combined operating weight of supported equipment and connected systems and components.
 - 2. Design seismic-restraint hangers and supports for piping and equipment.

72.4 SUBMITTALS

- A. Product Data: For each type of product indicated.
- B. Shop Drawings: Show fabrication and installation details and include calculations for the following; include Product Data for components:
 - 1. Equipment supports.

PART 73 - PRODUCTS

73.1 EQUIPMENT SUPPORTS

- A. Description: Welded, shop- or field-fabricated equipment support made from structural carbon-steel shapes.

73.2 MISCELLANEOUS MATERIALS

- A. Structural Steel: ASTM A 36/A 36M, carbon-steel plates, shapes, and bars; black and galvanized.
- B. Grout: ASTM C 1107, factory-mixed and -packaged, dry, hydraulic-cement, nonshrink and nonmetallic grout; suitable for interior and exterior applications.
 - 1. Properties: Nonstaining, noncorrosive, and nongaseous.
 - 2. Design Mix: **5000-psi**, 28-day compressive strength.

PART 74 - EXECUTION

74.1 EQUIPMENT SUPPORTS

- A. Fabricate structural-steel stands to suspend equipment from structure overhead or to support equipment above floor.
- B. Grouting: Place grout under supports for equipment and make bearing surface smooth.
- C. Provide lateral bracing, to prevent swaying, for equipment supports.

74.2 METAL FABRICATIONS

- A. Cut, drill, and fit miscellaneous metal fabrications for trapeze pipe hangers and equipment supports.
- B. Fit exposed connections together to form hairline joints. Field weld connections that cannot be shop welded because of shipping size limitations.
- C. Field Welding: Comply with AWS D1.1/D1.1M procedures for shielded, metal arc welding; appearance and quality of welds; and methods used in correcting welding work; and with the following:
 - 1. Use materials and methods that minimize distortion and develop strength and corrosion resistance of base metals.
 - 2. Obtain fusion without undercut or overlap.
 - 3. Remove welding flux immediately.
 - 4. Finish welds at exposed connections so no roughness shows after finishing and so contours of welded surfaces match adjacent contours.

74.3 ADJUSTING

- A. Hanger Adjustments: Adjust hangers to distribute loads equally on attachments and to achieve indicated slope of pipe.
- B. Trim excess length of continuous-thread hanger and support rods to **1-1/2 inches**.

74.4 PAINTING

- A. Touchup: Clean field welds and abraded areas of shop paint. Paint exposed areas immediately after erecting hangers and supports. Use same materials as used for shop painting. Comply with SSPC-PA 1 requirements for touching up field-painted surfaces.
 - 1. Apply paint by brush or spray to provide a minimum dry film thickness of **2.0 mils**.
- B. Galvanized Surfaces: Clean welds, bolted connections, and abraded areas and apply galvanizing-repair paint to comply with ASTM A 780.

END OF SECTION

SECTION 230553 - IDENTIFICATION FOR HVAC PIPING AND EQUIPMENT

PART 75 - GENERAL

75.1 RELATED DOCUMENTS

- A. Drawings and general provisions of the Contract, including General and Supplementary Conditions and Division 01 Specification Sections, apply to this Section.

75.2 SUMMARY

- A. Section Includes:

1. Equipment labels.

75.3 SUBMITTALS

- A. Product Data: For each type of product indicated.
- B. Samples: For color, letter style, and graphic representation required for each identification material and device.
- C. Equipment Label Schedule: Include a listing of all equipment to be labeled with the proposed content for each label.

75.4 COORDINATION

- A. Coordinate installation of identifying devices with completion of covering and painting of surfaces where devices are to be applied.
- B. Coordinate installation of identifying devices with locations of access panels and doors.
- C. Install identifying devices before installing acoustical ceilings and similar concealment.

PART 76 - PRODUCTS

76.1 EQUIPMENT LABELS

- A. Metal Labels for Equipment:

1. Material and Thickness: Brass, **0.032-inch**, Stainless steel, **0.025-inch**, Aluminum, **0.032-inch**, or anodized aluminum, **0.032-inch** minimum thickness, and having predrilled or stamped holes for attachment hardware.
2. Minimum Label Size: Length and width vary for required label content, but not less than **2-1/2 by 3/4 inch**.
3. Minimum Letter Size: **1/4 inch** for name of units if viewing distance is less than **24 inches**, **1/2 inch** for viewing distances up to **72 inches**, and proportionately larger

lettering for greater viewing distances. Include secondary lettering two-thirds to three-fourths the size of principal lettering.

4. Fasteners: Stainless-steel rivets or self-tapping screws.
5. Adhesive: Contact-type permanent adhesive, compatible with label and with substrate.

B. Plastic Labels for Equipment:

1. Material and Thickness: Multilayer, multicolor, plastic labels for mechanical engraving, **1/16 inch** thick, and having predrilled holes for attachment hardware.
2. Letter Color: Black.
3. Background Color: White.
4. Maximum Temperature: Able to withstand temperatures up to **160 deg F**.
5. Minimum Label Size: Length and width vary for required label content, but not less than **2-1/2 by 3/4 inch**.
6. Minimum Letter Size: **1/4 inch** for name of units if viewing distance is less than **24 inches (600 mm)**, **1/2 inch** for viewing distances up to **72 inches**, and proportionately larger lettering for greater viewing distances. Include secondary lettering two-thirds to three-fourths the size of principal lettering.
7. Fasteners: Stainless-steel rivets or self-tapping screws.
8. Adhesive: Contact-type permanent adhesive, compatible with label and with substrate.

C. Label Content: Include equipment's Drawing designation or unique equipment number, Drawing numbers where equipment is indicated (plans, details, and schedules), plus the Specification Section number and title where equipment is specified.

D. Equipment Label Schedule: For each item of equipment to be labeled, on **8-1/2-by-11-inch bond paper**. Tabulate equipment identification number and identify Drawing numbers where equipment is indicated (plans, details, and schedules), plus the Specification Section number and title where equipment is specified. Equipment schedule shall be included in operation and maintenance data.

PART 77 - EXECUTION

77.1 PREPARATION

- A. Clean equipment surfaces of substances that could impair bond of identification devices, including dirt, oil, grease, release agents, and incompatible primers, paints, and encapsulants.

77.2 EQUIPMENT LABEL INSTALLATION

- A. Install or permanently fasten labels on each major item of mechanical equipment.
- B. Locate equipment labels where accessible and visible.

END OF SECTION

SECTION 230593 - TESTING, ADJUSTING, AND BALANCING

PART 1 GENERAL

1.1 SECTION INCLUDES

- A. Testing, adjustment, and balancing of air systems.
- B. Measurement of final operating condition of HVAC systems.
- C. Commissioning activities.

1.2 ALLOWANCES

- A. Allowance includes testing, adjusting, and balancing of mechanical systems.

1.3 REFERENCES

- A. AABC MN-1 - AABC National Standards for Total System Balance; Associated Air Balance Council; 2002.
- B. ASHRAE Std 111 - Practices for Measurement, Testing, Adjusting and Balancing of Building Heating, Ventilation, Air-Conditioning, and Refrigeration Systems; American Society of Heating, Refrigerating and Air-Conditioning Engineers, Inc.; 1988.
- C. NEBB (TAB) - Procedural Standards for Testing Adjusting Balancing of Environmental Systems; National Environmental Balancing Bureau; 2005, Seventh Edition.
- D. SMACNA (TAB) - HVAC Systems Testing, Adjusting, and Balancing; Sheet Metal and Air Conditioning Contractors' National Association; 2002.

1.4 SUBMITTALS

- A. See Greenbook General Provisions _____, for submittal procedures.
- B. Qualifications: Submit name of adjusting and balancing agency and TAB supervisor for approval within 30 days after award of Contract.
- C. TAB Plan: Submit a written plan indicating the testing, adjusting, and balancing standard to be followed and the specific approach for each system and component.
 - 1. Submit to the Construction Manager.
 - 2. Submit six weeks prior to starting the testing, adjusting, and balancing work.
 - 3. Include certification that the plan developer has reviewed the contract documents, the equipment and systems, and the control system with the Architect and other installers to sufficiently understand the design intent for each system.

4. Include at least the following in the plan:
 - a. Preface: An explanation of the intended use of the control system.
 - b. List of all air flow, water flow, sound level, system capacity and efficiency measurements to be performed and a description of specific test procedures, parameters, formulas to be used.
 - c. Copy of field checkout sheets and logs to be used, listing each piece of equipment to be tested, adjusted and balanced with the data cells to be gathered for each.
 - d. Identification and types of measurement instruments to be used and their most recent calibration date.
 - e. Discussion of what notations and markings will be made on the duct and piping drawings during the process.
 - f. Final test report forms to be used.
 - g. Detailed step-by-step procedures for TAB work for each system and issue, including:
 - 1) Diffuser proportioning.
 - 2) Total flow calculations.
 - 3) Rechecking.
 - h. Expected problems and solutions, etc.
 - i. Criteria for using air flow straighteners or relocating flow stations and sensors.
 - j. Details of how TOTAL flow will be determined; for example:
 - 1) Air: Sum of terminal flows via control system calibrated readings or via hood readings of all terminals, supply (SA) and return air (RA) pitot traverse, SA or RA flow stations.
 - k. Specific procedures that will ensure that air side is operating at the lowest possible pressures and methods to verify this.
 - l. Confirmation of understanding of the outside air ventilation criteria under all conditions.
 - m. Method of verifying and setting minimum outside air flow rate will be verified and set and for what level (total building, zone, etc.).
 - n. Method of checking building static and exhaust fan and/or relief damper capacity.
 - o. Proposed selection points for sound measurements and sound measurement methods.
 - p. Methods for making coil or other system plant capacity measurements, if specified.

- q. Time schedule for TAB work to be done in phases (by floor, etc.).
 - r. Description of TAB work for areas to be built out later, if any.
 - s. Time schedule for deferred or seasonal TAB work, if specified.
 - t. False loading of systems to complete TAB work, if specified.
 - u. Exhaust fan balancing and capacity verifications, including any required room pressure differentials.
 - v. Procedures for field technician logs of discrepancies, deficient or uncompleted work by others, contract interpretation requests and lists of completed tests (scope and frequency).
 - w. Procedures for formal progress reports, including scope and frequency.
 - x. Procedures for formal deficiency reports, including scope, frequency and distribution.
- D. Control System Coordination Reports: Communicate in writing to the controls installer all setpoint and parameter changes made or problems and discrepancies identified during TAB which affect the control system setup and operation.
- E. Progress Reports.
- F. Final Report: Indicate deficiencies in systems that would prevent proper testing, adjusting, and balancing of systems and equipment to achieve specified performance.
1. Submit under as required per General Provisions.
 2. Submit to the Construction Manager and HVAC controls contractor within two weeks after completion of testing, adjusting, and balancing.
 3. Revise TAB plan to reflect actual procedures and submit as part of final report.
 4. Submit draft copies of report for review prior to final acceptance of Project. Provide final copies for Architect and for inclusion in operating and maintenance manuals.
 5. Provide reports in 3 ring binder manuals, complete with index page and indexing tabs, with cover identification at front and side. Include set of reduced drawings with air outlets and equipment identified to correspond with data sheets, and indicating thermostat locations.
 6. Include actual instrument list, with manufacturer name, serial number, and date of calibration.
 7. Form of Test Reports: Where the TAB standard being followed recommends a report format use that; otherwise, follow ASHRAE Std 111.
 8. Units of Measure: Report data in I-P (inch-pound) units only.
 9. Include the following on the title page of each report:
 - a. Name of Testing, Adjusting, and Balancing Agency.

- b. Address of Testing, Adjusting, and Balancing Agency.
 - c. Telephone number of Testing, Adjusting, and Balancing Agency.
 - d. Project name.
 - e. Project location.
 - f. Project Owner.
 - g. Project Engineer.
 - h. Project Contractor.
 - i. Project altitude.
 - j. Report date.
- G. Project Record Documents: Record actual locations of flow measuring stations and balancing valves and rough setting.

PART 2 PRODUCTS - NOT USED

PART 3 EXECUTION

3.1 GENERAL REQUIREMENTS

- A. Perform total system balance in accordance with one of the following:
 - 1. AABC MN-1, AABC National Standards for Total System Balance.
 - 2. NEBB Procedural Standards for Testing Adjusting Balancing of Environmental Systems.
 - 3. Maintain at least one copy of the standard to be used at project site at all times.
- B. Begin work after completion of systems to be tested, adjusted, or balanced and complete work prior to Substantial Completion of the project.
- C. Where HVAC systems and/or components interface with life safety systems, including fire and smoke detection, alarm, and control, coordinate scheduling and testing and inspection procedures with the authorities having jurisdiction.
- D. TAB Agency Qualifications:
 - 1. Company specializing in the testing, adjusting, and balancing of systems specified in this section.
 - 2. Not used.
 - 3. Certified by one of the following:
 - a. AABC, Associated Air Balance Council: www.aabchq.com; upon completion

submit AABC National Performance Guaranty.

b. NEBB, National Environmental Balancing Bureau: www.nebb.org.

- E. TAB Supervisor Qualifications: Certified by same organization as TAB agency.
- F. TAB Supervisor Qualifications: Professional Engineer licensed in the State in which the Project is located.

3.2 EXAMINATION

- A. Verify that systems are complete and operable before commencing work. Ensure the following conditions:
 - 1. Systems are started and operating in a safe and normal condition.
 - 2. Temperature control systems are installed complete and operable.
 - 3. Proper thermal overload protection is in place for electrical equipment.
 - 4. Duct systems are clean of debris.
 - 5. Fans are rotating correctly.
 - 6. Air outlets are installed and connected.
 - 7. Duct system leakage is minimized.
- B. Submit field reports. Report defects and deficiencies noted during performance of services which prevent system balance.
- C. Beginning of work means acceptance of existing conditions.

3.3 PREPARATION

- A. Hold a pre-balancing meeting at least one week prior to starting TAB work.
 - 1. Require attendance by all installers whose work will be tested, adjusted, or balanced.
- B. Provide instruments required for testing, adjusting, and balancing operations. Make instruments available to Owner to facilitate spot checks during testing.
- C. Provide additional balancing devices as required.

3.4 INSTALLATION TOLERANCES

- A. Air Handling Systems: Adjust to within plus or minus 10 percent of design for supply systems and plus or minus 10 percent of design for return and exhaust systems.

- B. Air Outlets and Inlets: Adjust total to within plus or minus 10 percent of design to space. Adjust outlets and inlets in space to within plus or minus 10 percent of design.

3.5 RECORDING AND ADJUSTING

- A. Field Logs: Maintain written logs including:
 - 1. Running log of events and issues.
 - 2. Discrepancies, deficient or uncompleted work by others.
 - 3. Contract interpretation requests.
 - 4. Lists of completed tests.
- B. Ensure recorded data represents actual measured or observed conditions.
- C. Permanently mark settings of valves, dampers, and other adjustment devices allowing settings to be restored. Set and lock memory stops.
- D. Mark on the drawings the locations where traverse and other critical measurements were taken and cross reference the location in the final report.
- E. After adjustment, take measurements to verify balance has not been disrupted or that such disruption has been rectified.
- F. Leave systems in proper working order, replacing belt guards, closing access doors, closing doors to electrical switch boxes, and restoring thermostats to specified settings.
- G. At final inspection, recheck random selections of data recorded in report. Recheck points or areas as selected and witnessed by the Owner.
- H. Check and adjust systems approximately six months after final acceptance and submit report.

3.6 AIR SYSTEM PROCEDURE

- A. Adjust air handling and distribution systems to provide required or design supply, return, and exhaust air quantities at site altitude.
- B. Make air quantity measurements in ducts by Pitot tube traverse of entire cross sectional area of duct.
- C. Use volume control devices to regulate air quantities only to extend that adjustments do not create objectionable air motion or sound levels. Effect volume control by duct internal devices such as dampers and splitters.
- D. Vary total system air quantities by adjustment of fan speeds. Provide drive changes

required. Vary branch air quantities by damper regulation.

- E. Provide system schematic with required and actual air quantities recorded at each outlet or inlet.

3.7 SCOPE

- A. Test, adjust, and balance the following:

1. Fans
2. Air Inlets and Outlets

3.8 MINIMUM DATA TO BE REPORTED

- A. Exhaust Fans:

1. Location
2. Manufacturer
3. Model number
4. Serial number
5. Air flow, specified and actual
6. Total static pressure (total external), specified and actual
7. Inlet pressure
8. Discharge pressure
9. Sheave Make/Size/Bore
10. Number of Belts/Make/Size
11. Fan RPM

END OF SECTION

SECTION 233113 - METAL DUCTS

PART 1 - GENERAL

1.1 SECTION INCLUDES

- A. Metal ductwork.
- B. Casing and plenums.

1.2 RELATED SECTIONS

- A. Section 099600 - High-Performance Coatings: Weld priming, weather resistant, paint or coating.
- B. Section 233300 - Air Duct Accessories.
- C. Section 233713 - Diffusers, Registers, and Grilles.
- D. Section 230593 - Testing, Adjusting, and Balancing.

1.3 REFERENCES

- A. ASTM A 653/A 653M - Standard Specification for Steel Sheet, Zinc-Coated (Galvanized) or Zinc-Iron Alloy-Coated (Galvannealed) by the Hot-Dip Process; 2005a.
- B. NFPA 90A - Standard for the Installation of Air Conditioning and Ventilating Systems; National Fire Protection Association; 2002.
- C. SMACNA (LEAK) - HVAC Air Duct Leakage Test Manual; Sheet Metal and Air Conditioning Contractors' National Association; 1985, First Edition.
- D. SMACNA (DCS) - HVAC Duct Construction Standards - Metal and Flexible; Sheet Metal and Air Conditioning Contractors' National Association; 2005.
- E. UL 181 - Standard for Factory-Made Air Ducts and Air Connectors; Underwriters Laboratories Inc.; 2005.

1.4 PERFORMANCE REQUIREMENTS

- A. No variation of duct configuration or sizes permitted except by written permission. Size round ducts installed in place of rectangular ducts in accordance with ASHRAE table of equivalent rectangular and round ducts.

1.5 SUBMITTALS

- A. See Greenbook General Provisions _____, for submittal procedures.

- B. Product Data: Provide data for duct materials, duct liner, and duct connections.
- C. Shop Drawings: Indicate duct fittings, particulars such as gages, sizes, welds, and configuration prior to start of work for all systems.
- D. Test Reports: Indicate pressure tests performed. Include date, section tested, test pressure, and leakage rate, following SMACNA (LEAK) - HVAC Air Duct Leakage Test Manual.
- E. Project Record Documents: Record actual locations of ducts and duct fittings. Record changes in fitting location and type. Show additional fittings used.

1.6 REGULATORY REQUIREMENTS

- A. Construct ductwork to NFPA 90A, NFPA 90B, and NFPA 96 standards.

1.7 ENVIRONMENTAL REQUIREMENTS

- A. Do not install duct sealants when temperatures are less than those recommended by sealant manufacturers.
- B. Maintain temperatures within acceptable range during and after installation of duct sealants.

PART 2 - PRODUCTS

2.1 MATERIALS

- A. Galvanized Steel Ducts: Hot-dipped galvanized steel sheet, ASTM A 653/A 653M FS Type B, with G90/Z275 coating.
- B. Joint Sealers and Sealants: Non-hardening, water resistant, mildew and mold resistant.
 1. Type: Heavy mastic or liquid used alone or with tape, suitable for joint configuration and compatible with substrates, and recommended by manufacturer for pressure class of ducts.
 2. VOC Content: Not more than 250 g/L, excluding water.
 3. Surface Burning Characteristics: Flame spread of zero, smoke developed of zero, when tested in accordance with ASTM E 84.
 4. For Use With Flexible Ducts: UL labeled.
- C. Hanger Rod: ASTM A 36/A 36M; steel, galvanized; threaded both ends, threaded one end, or continuously threaded.

2.2 DUCTWORK FABRICATION

- A. Fabricate and support in accordance with SMACNA HVAC Duct Construction Standards - Metal and Flexible, and as indicated. Provide duct material, gages, reinforcing, and sealing for operating pressures indicated.

2.3 DUCT MANUFACTURERS

- A. Metal-Fab, Inc: www.mtlfab.com.
- B. SEMCO Incorporated: www.semcoinc.com.
- C. United McGill Corporation: www.unitedmcgill.com.

2.4 MANUFACTURED METAL DUCTWORK AND FITTINGS

- A. Manufacture in accordance with SMACNA HVAC Duct Construction Standards - Metal and Flexible, and as indicated. Provide duct material, gages, reinforcing, and sealing for operating pressures indicated.

PART 3 - EXECUTION

3.1 INSTALLATION

- A. Install in accordance with manufacturer's instructions.
- B. Duct sizes indicated are inside clear dimensions. For lined ducts, maintain sizes inside lining.
- C. Install and seal metal and flexible ducts in accordance with SMACNA HVAC Duct Construction Standards - Metal and Flexible.
- D. Provide openings in ductwork where required to accommodate thermometers and controllers. Provide pilot tube openings where required for testing of systems, complete with metal can with spring device or screw to ensure against air leakage. Where openings are provided in insulated ductwork, install insulation material inside a metal ring.
- E. Locate ducts with sufficient space around equipment to allow normal operating and maintenance activities.
- F. Use crimp joints with or without bead for joining round duct sizes 8 inch (200 mm) and smaller with crimp in direction of air flow.
- G. Use double nuts and lock washers on threaded rod supports.

3.2 SCHEDULES

- A. Ductwork Material:
 - 1. General Exhaust & Outside Air: Galvanized Steel.

B. Ductwork Pressure Class:

1. General Exhaust & Outside Air: 1 inch (250 Pa).

END OF SECTION

SECTION 233300 - AIR DUCT ACCESSORIES

PART 1 - GENERAL

1.1 SECTION INCLUDES

- A. Backdraft dampers.
- B. Duct access doors.
- C. Duct test holes.

1.2 RELATED SECTIONS

- B. Section 233113 - Metal Ducts.

1.3 REFERENCES

- A. NFPA 90A - Standard for the Installation of Air Conditioning and Ventilating Systems; National Fire Protection Association; 2002.
- B. SMACNA (DCS) - HVAC Duct Construction Standards - Metal and Flexible; Sheet Metal and Air Conditioning Contractors' National Association; 2005.

1.4 SUBMITTALS

- A. See Greenbook General Provisions , for submittal procedures.
- B. Product Data: Provide for shop fabricated assemblies including volume control dampers, duct access doors, duct test holes, and hardware used. Include electrical characteristics and connection requirements.
- C. Shop Drawings: Indicate for shop fabricated assemblies including volume control dampers, duct access doors, and duct test holes.

1.5 PROJECT RECORD DOCUMENTS

- A. Record actual locations of access doors and test holes.

1.6 QUALITY ASSURANCE

- A. Manufacturer Qualifications: Company specializing in manufacturing the type of products specified in this section .

- B. Products Requiring Electrical Connection: Listed and classified by Underwriters Laboratories Inc. as suitable for the purpose specified and indicated.

1.7 EXTRA MATERIALS

- A. See Greenbook General Provisions, for additional provisions.

PART 2 - PRODUCTS

2.1 BACKDRAFT DAMPERS

- A. Manufacturers:
 - 1. Nailor Industries Inc: www.nailor.com.
 - 2. Ruskin Company: www.ruskin.com.
 - 3. Greenheck.
- B. Gravity Backdraft Dampers, Size 18 x 18 inches (450 x 450 mm) or Smaller, Furnished with Air Moving Equipment: Air moving equipment manufacturer's standard construction.
- C. Multi-Blade, Parallel Action Gravity Balanced Backdraft Dampers: galvanized steel, with center pivoted blades of maximum 6 inch (150 mm) width, with felt or flexible vinyl sealed edges, linked together in rattle-free manner with 90 degree stop, steel ball bearings, and plated steel pivot pin; adjustment device to permit setting for varying differential static pressure.

2.2 DUCT ACCESS DOORS

- A. Manufacturers:
 - 1. Nailor Industries Inc: www.nailor.com.
 - 2. Ruskin Company: www.ruskin.com.
 - 3. SEMCO Incorporated: www.semcoinc.com.
- B. Fabricate in accordance with SMACNA HVAC Duct Construction Standards - Metal and Flexible, and as indicated.
- C. Fabrication: Rigid and close-fitting of galvanized steel with sealing gaskets and quick fastening locking devices. For insulated ducts, install minimum 1 inch (25 mm) thick insulation with sheet metal cover.
 - 1. Less Than 12 inches (300 mm) Square: Secure with sash locks.

2. Up to 18 inches (450 mm) Square: Provide two hinges and two sash locks.
3. Up to 24 x 48 inches (600 x 1200 mm): Three hinges and two compression latches with outside and inside handles.
4. Larger Sizes: Provide an additional hinge.
5. Sash Lock.

2.3 DUCT TEST HOLES

- A. Temporary Test Holes: Cut or drill in ducts as required. Cap with neat patches, neoprene plugs, threaded plugs, or threaded or twist-on metal caps.
- B. Permanent Test Holes: Factory fabricated, air tight flanged fittings with screw cap. Provide extended neck fittings to clear insulation.

PART 3 - EXECUTION

3.1 PREPARATION

- A. Verify that electric power is available and of the correct characteristics.

3.2 INSTALLATION

- A. Provide backdraft dampers on exhaust fans or exhaust ducts nearest to outside and where indicated.
- B. Provide duct access doors for inspection and cleaning before and after filters, coils, fans, automatic dampers, and elsewhere as indicated. Review locations prior to fabrication.
- C. Provide duct test holes where indicated and required for testing and balancing purposes.

END OF SECTION

SECTION 233423 - HVAC POWER VENTILATORS

PART 1 - GENERAL

1.1 SECTION INCLUDES

- A. Centrifugal roof ventilator.

1.2 RELATED SECTIONS

- A. Section 233300 – Air Duct Accessories: Backdraft dampers.
- B. Section 262726 - Wiring Devices: Electrical characteristics and wiring connections.

1.3 REFERENCES

- A. AMCA 99 - Standards Handbook; Air Movement and Control Association International, Inc.; 2003.
- B. AMCA 210 - Laboratory Methods of Testing Fans for Aerodynamic Performance Rating; Air Movement and Control Association International, Inc.; 1999 (ANSI/AMCA 210, same as ANSI/ASHRAE 51).
- C. AMCA (DIR) - [Directory of] Products Licensed Under AMCA International Certified Ratings Program; Air Movement and Control Association International, Inc.; <http://www.amca.org/licenses/search.aspx>.
- D. AMCA 300 - Reverberant Room Method for Sound Testing of Fans; Air Movement and Control Association International, Inc.; 2005.
- E. AMCA 301 - Methods for Calculating Fan Sound Ratings from Laboratory Test Data; Air Movement and Control Association International, Inc.; 2006.
- F. NEMA MG 1 - Motors and Generators; National Electrical Manufacturers Association; 2006.
- G. NFPA 96 - Standard for Ventilation Control and Fire Protection of Commercial Cooking Operations; National Fire Protection Association; 2004.
- H. UL 705 - Power Ventilators; Underwriters Laboratories Inc.; 2004.

1.4 SUBMITTALS

- A. See Greenbook General Provisions , for submittal procedures.
- B. Product Data: Provide data on fans and accessories including fan curves with specified

operating point clearly plotted, power, RPM, sound power levels at rated capacity, and electrical characteristics and connection requirements.

- C. Manufacturer's Instructions: Indicate installation instructions.
- D. Maintenance Data: Include instructions for lubrication, motor and drive replacement, spare parts list, and wiring diagrams.

1.5 QUALITY ASSURANCE

- A. Manufacturer Qualifications: Company specializing in manufacturing the type of products specified in this section
- B. Products Requiring Electrical Connection: Listed and classified by Underwriters Laboratories Inc. as suitable for the purpose specified and indicated.

1.6 ENVIRONMENTAL REQUIREMENTS

- A. Do not operate fans for any purpose until ductwork is clean, filters are in place, bearings have been lubricated, and fan has been test run under observation.

1.7 EXTRA MATERIALS

- A. See Greenbook General Provisions, for additional provisions.

PART 2 - PRODUCTS

2.1 MANUFACTURERS

- A. Loren Cook Company: www.lorencook.com.
- B. Greenheck: www.greenheck.com.
- C. Twin City Fans.

2.2 CENTRIFUGAL ROOF VENTILATOR

- C. Description:
 1. Factory-fabricated, -assembled, -tested, and -finished, belt-driven centrifugal fans consisting of housing, wheel, fan shaft, bearings, motor, drive assembly, and support structure.
 2. Deliver fans as factory-assembled units, to the extent allowable by shipping limitations.
 3. Factory-installed and -wired disconnect switch.

D. Housings:

1. Formed panels to make curved-scroll housings with shaped cutoff.
2. Panel Bracing: Steel angle- or channel-iron member supports for mounting and supporting fan scroll, wheel, motor, and accessories.
3. Horizontally split, bolted-flange housing.
4. Spun inlet cone with flange.
5. Outlet flange.

E. Forward-Curved Wheels:

1. Black-enameled or galvanized-steel construction with inlet flange, backplate, shallow blades with inlet and tip curved forward in direction of airflow.
2. Mechanically secured to flange and backplate; cast-steel hub swaged to backplate and fastened to shaft with set screws.

F. Shafts:

1. Statically and dynamically balanced and selected for continuous operation at maximum rated fan speed and motor horsepower, with adjustable alignment and belt tensioning.
2. Turned, ground, and polished hot-rolled steel with keyway. Ship with protective coating of lubricating oil.
3. Designed to operate at no more than 70 percent of first critical speed at top of fan's speed range.

G. Grease-Lubricated Shaft Bearings:

1. Self-aligning, pillow-block-type, ball or roller bearings with adapter mount and two-piece, cast-iron housing.
2. Ball-Bearing Rating Life: ABMA 9, L10 at 50,000 hours.

H. Accessories:

1. Access for Inspection, Cleaning, and Maintenance: Comply with requirements in ASHRAE 62.1.
2. Scroll Drain Connection: NPS 1 (DN 25) steel pipe coupling welded to low point of fan scroll.

PART 3 - EXECUTION

3.1 INSTALLATION

- A. Install in accordance with manufacturer's instructions. Provide mounting hardware.

END OF SECTION

SECTION 233713 - DIFFUSERS, REGISTERS, AND GRILLES

PART 1 - GENERAL

1.1 SECTION INCLUDES

- A. Registers/grilles.

1.2 RELATED SECTIONS

- A. Section 099600 - High-Performance Coatings: Painting of ducts visible behind outlets and inlets.

1.3 REFERENCES

- A. AMCA 500-L - Laboratory Methods of Testing Louvers for Rating; Air Movement and Control Association International, Inc.; 1999.
- B. ARI 890 - Standard for Air Diffusers and Air Diffuser Assemblies; Air-Conditioning and Refrigeration Institute; 2001.
- C. ASHRAE Std 70 - Method of Testing for Rating the Performance of Air Outlets and Inlets; American Society of Heating, Refrigerating and Air Conditioning Engineers, Inc.; 2006.
- D. SMACNA (DCS) - HVAC Duct Construction Standards - Metal and Flexible; Sheet Metal and Air Conditioning Contractors' National Association; 2005.

1.4 SUBMITTALS

- A. See Greenbook General Provisions for submittal procedures.
- B. Product Data: Provide data for equipment required for this project. Review outlets and inlets as to size, finish, and type of mounting prior to submission. Submit schedule of outlets and inlets showing type, size, location, application, and noise level.
- C. Project Record Documents: Record actual locations of air outlets and inlets.

1.5 QUALITY ASSURANCE

- A. Test and rate air outlet and inlet performance in accordance with ASHRAE Std 70.

1.6 QUALITY ASSURANCE

- A. Manufacturer Qualifications: Company specializing in manufacturing the type of products specified in this section

PART 2 - PRODUCTS

2.1 MANUFACTURERS

- A. Titus: www.titus-hvac.com.
- B. Krueger: www.krueger-hvac.com.
- C. Metalaire.

2.2 FIXED FACE BAR TYPE RETURN GRILLES "A"

- A. Type: Streamlined, 1/8 by 3/4 inch blades on 3/4 inch centers. 35 degree deflection.
- B. Frame: 1-1/4" wide, surface mount type. In plaster ceilings, provide plaster frame and ceiling frame.
- C. Fabrication: Steel with 20 gauge minimum frames and 22 gauge minimum blades, steel with factory finish

PART 3 - EXECUTION

3.1 INSTALLATION

- A. Install in accordance with manufacturer's instructions.
- B. Check location of outlets and inlets and make necessary adjustments in position to conform with architectural features, symmetry, and lighting arrangement.
- C. Install diffusers to ductwork with air tight connection.
- D. Paint ductwork visible behind air outlets and inlets matte black. Refer to Section 09 96 00.

END OF SECTION

SECTION 260500 - GENERAL ELECTRICAL REQUIREMENTS

PART 1 - GENERAL

1.1 RELATED DOCUMENTS

- A. Drawings and general provisions of the Contract, including General and Supplementary Conditions and Division 1 Specification Sections.
- B. All Specification Sections under Division 26.

77.4 SUMMARY

- A. This Section includes:
 - 1. Definitions.
 - 2. Excavation.
 - 3. Coordination of work.
 - 4. Cleaning, patching repairing and painting.
 - 5. Guarantees.
 - 6. Field test.

77.5 REFERENCES

- A. American National Standards Institute, Inc. (ANSI) Publications:
 - 1. C2 - National Electrical Safety Code.
 - 2. C37 – Metal-Enclosed Low-Voltage Power Circuit Breaker Switchgear.
 - 3. C37 – Metal-Clad and Station-Type Cubicle Switchgear.
 - 4. C37 – Metal-Enclosed Interrupter Switchgear.
- B. California Code of Regulations (CCR) Publications:
 - 1. Title 8, Industrial Relations.
 - 2. Title 19, State Fire Marshal Regulations.
 - 3. Title 24, Part 2, Energy Conservation Standards.
 - 4. Title 24, Part 3, CCR, 2016 California Electrical Code.
 - 5. Title 24, Part 9, CCR, 2016 California Fire Code.
- C. National Electrical Manufacturers Association (NEMA) Publication: ICS6-93 Enclosures for Industrial Controls and Systems.
- D. National Fire Protection Association (NFPA) Publications:
 - 1. 70 National Electrical Code (NEC).
 - 2. 70B Recommended Practice for Electrical Equipment Maintenance.
- E. State of California Public Utilities Commission (Cal. P.U.C.) Publications:

1. G.O. 95 Rules for Overhead Electric Line Construction.
2. G.O. 128 Rules for Construction of Underground Electrical Supply and Communications Systems.

77.6 DEFINITIONS

The following definitions apply to terms used in these standards.

- A. The words "work" or "electrical work" include products, labor, equipment, tools, appliances, transportation, and all related items directly or indirectly required to complete the specified and indicated electrical installation.
- B. The word "concealed" shall mean that the installation will not be visible when all permanent or removable elements of the construction are in place. The word "exposed" shall mean that the installation is visible when all permanent or removable elements of the construction are in place.
- C. The word "code" shall mean any and all regulations and requirements of regulatory bodies, public and private, having jurisdiction over the work involved.
- D. The word "product" used in Division 26 means all material, equipment, machinery, and/or appliances directly or indirectly required to complete the specified and/or indicated electrical work.
- E. The words "standard product" shall mean a manufactured product, illustrated and/or described in catalogs or brochures that is in general distribution prior to the date of issue of construction documents. Products will generally be identified by means of a specific catalog number and manufacturer's name.
- F. "Provide" means furnish, install, connect and test unless otherwise noted.
- G. The words "conduit" and "duct" are used interchangeably, and have the same meaning.
- H. "UFER" Ground: See Section 26 0526, "Grounding and Bonding".

77.7 DRAWINGS AND SPECIFICATIONS:

- A. Electrical drawings are diagrammatic but shall be followed as closely as actual construction and work of the other sections shall permit. Size and location of equipment is drawn to scale wherever possible.
- B. Drawings and specifications are for the assistance and guidance of the Contractor. Exact locations, distances, and levels will be governed by the building. The Contractor shall make use of data in all the contract documents to verify information at the building site.
- C. In any case where there appears to be a conflict or ambiguity between that which is shown on the electrical drawings or in the electrical specifications and any other part of the Contract Documents, the Contractor shall notify and secure directions from the Architect.
- D. Drawings and specifications are intended to complement each other. Where a conflict or ambiguity exists between the requirements of the drawings and the specifications, request clarification. Do not proceed with work without direction.

- E. The Architect shall interpret the drawings and the specifications. The interpretation by the Architect as to the true intent and meaning thereof and the quality, quantity, and sufficiency of the materials and workmanship furnished there under shall be accepted as final and conclusive.
- F. In the case of conflicts or ambiguities not clarified prior to the bidding deadline, use the most costly alternative (better quality, greater quantity, and larger size) in preparing the bid. A clarification will be issued to the successful bidder as soon as feasible after the award and, if appropriate, a deductive change order will be issued.
- G. Where items are specified in the singular, this division shall provide the quantity as shown on drawings plus any spares or extras indicated on the drawings or in the specifications.

77.8 RECORD DRAWINGS:

- A. On one (1) set of contract drawings, kept at the site during construction, mark all work that is installed differently from that shown on plans, including revised circuitry, material or equipment. Sufficient dimensions shall be provided to locate all materials installed beneath and outside the building including, but not limited to, underground conduits, cabling, ground rods, and stubouts.
- B. All changes or revisions to the contract drawings including, but not limited to, those indicate by amendment, change order, field order, written response to RFI/RFC or other contractual means shall be kept current as the work progresses and shall be incorporated onto the final record drawings.
- C. Accurately locate and dimension all underground and embedded conduit runs on the record drawings.
- D. The marked drawings shall be kept current as the work progresses and shall be available for inspection upon request. At the close of construction, prepare a set of accurate reproducible record drawings and turn them over to the Architect. The correct and completed record drawings are a prerequisite to final contract payment.
 - 1. As part of the reproducible record drawings, the Contractor shall produce full size reproducible drawings with the: Final panelboard schedules as modified during construction and final light fixture schedule as modified during construction.
 - 2. These drawings shall be on Architectural base sheets and numerically sequenced to follow the last "E" sheet.
- E. As part of the reproducible record drawings, the Contractor shall produce full size reproducible drawings for all signal systems which shall include exact "As-Built" device locations, "As-Built" interconnection drawings, and "As-Built" riser diagrams, and provide one set in the panel board, motor control center, or main distribution panel.

77.9 EXAMINATION OF SITE:

- A. Examination of the building site shall be made by the Contractor. The Contractor shall compare it with the drawings and specification and satisfy himself as to the conditions

under which work is to be performed. The Contractor shall, at such time, ascertain and check the locations of existing structures or equipment which may affect his work.

77.10 EXCAVATION

- A. Prior to starting excavation or trenching, the Contractor shall perform an underground Site Survey utilizing an electronic locator to verify the exact location of all existing underground utility piping, conduits and conductors. The Contractor shall submit for approval a site survey report to the Architect within five (5) working days after the survey is performed. The Site Survey Report shall show the horizontal location for existing utilities and identify any possible conflicts between the new work and existing utilities.

77.11 PERMITS, FEES AND INSPECTIONS:

- A. Permits, fees, and inspections shall be arranged for and paid by the Contractor.
- B. The Contractor shall present to the Architect, properly signed certificates of the final inspection before work will be accepted.

77.12 ELECTRO-MECHANICAL REQUIREMENTS:

- A. The power wiring, safety switches, combination controllers (indicated on electrical plans), circuit breakers, and motor control equipment forming a part of motor-control centers or switchgear assemblies, and the electrical connection of the mechanical equipment to the electrical power source shall be included under Division 26.
- B. The electrical components of mechanical equipment including, but not limited to, motors, motor-starters, control or pushbutton stations, float-pressure switches, solenoid valves, thermostats, junction boxes, and other devices functioning to control mechanical equipment shall be provided under Division 15. Interconnecting wiring for packaged equipment shall be provided as an integral part of the equipment.
- C. Control Wiring: Installation of line and low voltage conduit, wiring and junction/outlet boxes not shown on the electrical drawings but required for controlling or monitoring mechanical equipment systems shall be furnished and installed under Division 15. Installation of these shall comply with the requirements of Division 26.
- D. If substitution of controls or mechanical equipment other than that specified requires any changes in the electrical work from that shown on the plans or specified in Division 26, any additional cost of the equipment or electrical work shall be the responsibility of Division 15.

1.11 SUBMITTALS:

- E. Submittal requirements for Division 26 shall be in accordance with Division 1 except as modified herein. All time requirements shall be based on the notice to proceed date of the General Contract. All materials and equipment furnished under Division 26 shall; be

submitted to the Architect for approval. Such approval shall be in writing from the Architect including that which is exactly as specified. Any materials or equipment installed without written approval shall be subject to immediate removal. Approval of material or equipment shall in no way obviate compliance with the contract documents.

- F. Submittals shall be packaged separately for each system or major piece of equipment and reviewed by the Contractor for verification of compliance with the contract documents prior to submitting to the Architect. Separate, bound submittals shall be provided for each specification section to the Architect. Authorization to combine equipment or systems must be in writing from the Architect. All interface between specification sections shall be indicated in each submittal.
- G. All materials and equipment shall be new and shall bear the inspection label of the Underwriters Laboratories (UL) where applicable. Materials and equipment shall be the latest standard product and shall be of the grade indicated by the trade names given.
- H. The work shown on the contract drawings is engineered and designed to accommodate the equipment described hereinafter in these specifications.
- I. Equipment submittal shall include manufacturer's name, model, type, number, finish, size and capacity of the equipment at the given conditions. This information shall be provided in bound submittals, each containing an index and all submittals. Provide [seven (7)] copies of each submittal. The title shall provide the project name, system identity, the specification number, and the Contractor's name and address. This submittal shall be in addition to the shop drawings hereinafter specified. Partial submittals of material submitted from time to time are not acceptable and may be returned without review.
- J. Submittals shall be reviewed by the Architect for compliance with the contract documents. Submittals found to be incomplete or not in compliance with the contract documents shall be returned for resubmittal. The Architect shall review the original submittal and one (1) resubmittal per section (if required). The Contractor shall reimburse the Architect for all subsequent submittal review.
- K. Equipment Layout Drawings: "Equipment Layout Drawings" shall be provided for each equipment room, yard or area containing equipment items furnished under Division 26. Layout drawings shall consist of a plan view of the room or area (to a ¼ inch = 1 foot – 0 inch minimum scale) showing projected outlines of all equipment, complete with dotted lines indicating all required clearances, including all clearances needed for removal or service. Location of all conduit and pull boxes shall be indicated. Drawings shall indicate any and all conflicts with other trades.

1.12 SUBSTITUTIONS:

- A. Equipment submitted for substitution must fit the space conditions shown on the drawings, leaving adequate room for maintenance around all equipment. A minimum of 48 inches (or more if required by Code) must be maintained clear in front of all electrical panels, starters, gutters or other electrical apparatus. Submit drawings showing the layout, size, and exact method of interconnection of conduit, wiring and controls, which shall conform to the manufacturer's recommendations and these specifications. The scale of these drawings shall be the scale of the contract drawings. The Contractor shall bear the excess costs, by any and all crafts, for fitting the equipment into the space and the system designated. Where additional labor or material is required to permit equipment submitted for

substitution to function in an approved manner, this shall be furnished and installed by the Contractor without additional cost to the Owner.

2. No substitutions will be allowed for materials or equipment if three (3) or more manufacturers are indicated.
- L. An item submitted for substitution does not constitute an "equal" unless approval by the Architect has been given in writing.
- M. Equipment submitted for substitution shall be approved in writing by the Architect and shall be accompanied by the following:
 1. A sample of each item submitted for substitution shall accompany the submittal if requested by the Architect.
 2. A unit price quotation shall be provided with each item intended for substitution. This quote shall include a unit price for the specified item and a unit price for the intended substitute item. The Contractor shall also provide a total (per item) of the differential payback to the Owner should the intended substitute item be approved as equivalent to that which is specified.
 3. The Contractor shall reimburse the Owner for the additional services required by the Architect to review and process substitutions.
- N. Substitutions shall be approved in writing by the Architect. The determination of the Architect shall be final.

1.13 WARRANTY:

- O. Warranty requirements for Division 26 shall be in accordance with Division 1 except as modified herein.
- P. All materials and equipment provided shall be warranted for a minimum period of one (1)-year from the official date of completion. In addition, provide two (2)-year extended warranty, for a total of three (3)-years, for the following items:
 1. Disconnect Switches.
 2. Panelboards.
 3. Circuit Breakers.
- Q. The Contractor shall provide all labor and materials required to correct problems which develop during the warranty period due to defective materials or faulty workmanship. The labor and materials to do this work shall be provided at no additional cost to the Owner.
- R. Within one (1)-month prior to the expiration of the warranty period, the Contractor shall correct any and all defects covered by the warranty. This shall include tightening to original specifications of all bolted connections.
- S. Warranty certificates shall be made out to Vista Unified School District and shall be delivered to the Architect at the completion of the installation.
- T. All equipment shall be guaranteed to be supported in such a way as to be free from objectionable vibration and noise.

- U. Additional warranty requirement shall be as indicated in the following sections of Division 26.

1.14 OPERATION AND MAINTENANCE MANUALS:

- V. The Contractor shall furnish operation and maintenance manuals for each electrical system and for each piece of equipment. The complete manual, bound in hardback binders, or an approved equivalent, shall be provided to the Architect. Provide Seven (7) copies of each manual. One (1) manual shall be furnished prior to the time that system or equipment tests are performed, and the remaining manuals shall be furnished one (1) week before the final job visit is made. The following identification shall be inscribed on the cover; the words "OPERATION AND MAINTENANCE MANUAL", the name and location of the building, the name of the Contractor, and the contract number.
- W. The manual shall include the names, address, and the telephone numbers of each Subcontractor installing equipment and systems, and of the local representatives for each item of equipment and each system. The manual shall have a table of contents and be assembled to conform to the table of contents with tab sheets placed before instructions covering each subject. The instruction sheet shall be legible with large sheets of drawings folded in. The Manual shall include, but not limited to, the following:
 1. System layout showing components.
 2. Devices and controls.
 3. Wiring and control diagrams showing operation and control of each component.
 4. Sequence of operation describing start-up, operation, and shutdown.
 5. Functional description of the principal system components.
 6. Installation instructions.
 7. Maintenance and overhaul instructions.
 8. Lubrication schedule including type, grade, temperature, range, and frequency.
 9. Safety precautions, diagrams and illustrations.
 10. Test procedures.
 11. Performance data.
 12. Parts list.
- X. The parts list for equipment shall indicate the sources of supply, recommended spare parts, and the service organization which is reasonably convenient to the building sit. The manual shall be complete in all respects for all equipment, controls, and accessories provided.

1.15 COORDINATION OF ALL WORK:

- Y. Job Visits by the Architect:
 1. Periodic visits to the job by the Architect are for the express purpose of verifying compliance with the contract documents.
 2. Such visits shall not be construed as construction supervision. Neither shall such visits be construed as making the Architect responsible for providing a safe place for the performance of the work by the Contractor or the Contractor's employees or the safety of the supplies of the Contractor or his Subcontractors.
- Z. Temporary Electrical Service:

1. The Contractor shall provide labor and materials required for the installation and maintenance of temporary lighting and required power sources for the Contractor's equipment inside the building or construction site and for pedestrian walkways during the period of construction.
2. The building or construction site shall be sufficiently illuminated so that construction work can be safely performed. Special attention shall be given to adequately lighting stairs, ladders, pedestrian walkways, floor openings, etc. Walkway lights shall be controlled by a switch within the building or construction site.
3. Power shall be on and all lighting shall be in operation before painting work commences.

AA. Posted Operating Instructions:

1. Operating instructions shall be provided by the Contractor at the conclusion of the project for each system and each principal piece of equipment for the use of operating and maintenance personnel. The operating instructions shall include wiring and control diagrams showing the entire system, including, but not limited to, equipment, devices, and control sequences. All operating instruction shall be approved by the Architect.
2. Operating instructions shall be typewritten or engraved and shall be framed under glass or in approved laminated plastic and posted adjacent to each principal piece of equipment and shall include such instructions as start up, proper adjustment, operation, lubrication, shutdown, safety-precautions, procedure in the event of equipment failure, and any other necessary items of instructions as recommended by the manufacturer of unit.
3. Operating instructions exposed to the weather shall be made of weather-resisting materials or shall be suitably enclosed to be weather protected. Operating instructions shall not face when exposed to sunlight and shall be secured to prevent easy removal or peeling.

1.16 TRAINING:

- BB. User staff and maintenance personnel shall be thoroughly trained (minimum four (4)-hours) in the use of each system or major piece of equipment installed. This training shall be provided a part of the Contractors bid to supply the system or equipment. Additional training requirements, shall be as specified in the subsequent sections of Division 26.

1.17 DELIVERY AND STORAGE:

- CC. Equipment and materials shall be properly stored, adequately protected, and carefully handled to prevent damage before and during installation. Equipment and materials shall be handled, stored, and protected in accordance with the manufacturer's recommendations and as approved by the Architect. Electrical conduit shall be stored to provide protection from the weather and accidental damage. Plastic conduit shall be stored on even supports and in locations not subject to direct sunrays or excessive heat. Cables shall be sealed, stored, and handled carefully to avoid damage to the outer covering or insulation and damage from moisture and weather. Damaged or defective items shall be replaced with new items a no cost to the Owner. The Architect shall determine if a damaged or defective item is to be replaced with a new item. The decisions by the Architect in these matters shall be final.

1.18 FIELD TESTS:

DD. As an exception to requirements that may be stated elsewhere in the contract, the Architect shall be given five (5) working days notice prior to each test. The Contractor shall provide all test equipment, personnel and incidentals including, but not limited to, water, fuel, and lubricants necessary to perform the required tests. Inspections are to be performed by an independent third party and are intended to ensure that the work of the prime contractor is in accordance with the Contract Documents and applicable building codes. The Owner shall provide electrical power required for all tests. The Contractor shall submit five (5) typewritten copies of all test results to the Architect within five (5) working days after each test.

1. The information submitted shall include, but not limited to, the following:
 - a. Scope of the test.
2. Name and type of instrument used.
3. Calibration date of instrument and name of calibration firm.
4. Name and signature of testing personnel.
5. Name of signature of Architect.
6. Analysis of test results.
7. The Contractor shall demonstrate to the Architect the operation of all equipment and systems. All tests shall be completed to the satisfaction of the Architect. Each test shall be performed the number of time indicated in the individual specification section. In the event the number of times the tests are to be completed is omitted, the Architect shall determine the number.

END OF SECTION

SECTION 260519 - LOW-VOLTAGE ELECTRICAL POWER CONDUCTORS AND CABLES

PART 78 - GENERAL

78.1 SUMMARY

- A. This Section includes the following:
 - 1. Building wires and cables rated 600 V and less.
 - 2. Connectors, splices, and terminations rated 600 V and less.

78.2 ACTION SUBMITTALS

- A. Product Data: For each type of product indicated.

78.3 INFORMATIONAL SUBMITTALS

- A. Field quality-control test reports.

78.4 QUALITY ASSURANCE

- A. Electrical Components, Devices, and Accessories: Listed and labeled as defined in NFPA 70, Article 100, by a testing agency acceptable to authorities having jurisdiction, and marked for intended use.
- B. Comply with NFPA 70.

PART 79 - PRODUCTS

79.1 CONDUCTORS AND CABLES

- A. Aluminum and Copper Conductors: Comply with NEMA WC 70.
- B. Conductor Insulation: Comply with NEMA WC 70 for Types THHN-THWN, XHHW.
- C. Multiconductor Cable: Comply with NEMA WC 70 for armored cable, Type AC or metal-clad cable, Type MC with ground wire.

79.2 CONNECTORS AND SPLICES

- A. Available Manufacturers: Subject to compliance with requirements, manufacturers offering products that may be incorporated into the Work include, but are not limited to, the following:
 - 1. AFC Cable Systems, Inc.
 - 2. Hubbell Power Systems, Inc.

3. O-Z/Gedney; EGS Electrical Group LLC.
 4. 3M; Electrical Products Division.
 5. Tyco Electronics Corp.
- B. Description: Factory-fabricated connectors and splices of size, ampacity rating, material, type, and class for application and service indicated.

PART 80 - EXECUTION

80.1 CONDUCTOR MATERIAL APPLICATIONS

- A. Feeders: Copper for feeders smaller than No. 1 AWG; aluminum for feeders No. 1 AWG and larger. Solid for No. 10 AWG and smaller; stranded for No. 8 AWG and larger.
- B. Branch Circuits: Copper. Solid for No. 10 AWG and smaller; stranded for No. 8 AWG and larger.

80.2 CONDUCTOR INSULATION AND MULTICONDUCTOR CABLE APPLICATIONS AND WIRING METHODS

- A. Service Entrance: Type XHHW, single conductors in raceway.
- B. Exposed Feeders: Type THHN-THWN, single conductors in raceway.
- C. Feeders Concealed in Ceilings, Walls, Partitions, and Crawlspace: Type THHN-THWN, single conductors in raceway.
- D. Feeders Concealed in Concrete, below Slabs-on-Grade, and Underground: Type THHN-THWN, single conductors in raceway.
- E. Exposed Branch Circuits, Including in Crawlspace: Type THHN-THWN, single conductors in raceway.
- F. Branch Circuits Concealed in Ceilings, Walls, and Partitions: Type THHN-THWN, single conductors in raceway, Armored cable, Type AC or Metal-clad cable, Type MC.
- G. Branch Circuits Concealed in Concrete, below Slabs-on-Grade, and Underground: Type THHN-THWN, single conductors in raceway.
- H. Cord Drops and Portable Appliance Connections: Type SO, hard service cord with stainless-steel, wire-mesh, strain relief device at terminations to suit application.
- I. Class 1 Control Circuits: Type THHN-THWN, in raceway.
- J. Class 2 Control Circuits: Type THHN-THWN, in raceway or Power-limited cable, concealed in building finishes.

80.3 INSTALLATION OF CONDUCTORS AND CABLES

- A. Conceal cables in finished walls, ceilings, and floors, unless otherwise indicated.

- B. Use manufacturer-approved pulling compound or lubricant where necessary; compound used must not deteriorate conductor or insulation. Do not exceed manufacturer's recommended maximum pulling tensions and sidewall pressure values.
- C. Use pulling means, including fish tape, cable, rope, and basket-weave wire/cable grips, that will not damage cables or raceway.
- D. Install exposed cables parallel and perpendicular to surfaces of exposed structural members, and follow surface contours where possible.
- E. Support cables according to Division 26 Sections "Hangers and Supports for Electrical Systems."
- F. Identify and color-code conductors and cables according to Division 26 Section "Identification for Electrical Systems."
- G. Tighten electrical connectors and terminals according to manufacturer's published torque-tightening values. If manufacturer's torque values are not indicated, use those specified in UL 486A and UL 486B.
- H. Make splices and taps that are compatible with conductor material and that possess equivalent or better mechanical strength and insulation ratings than unspliced conductors.
 - 1. Use oxide inhibitor in each splice and tap conductor for aluminum conductors.
- I. Wiring at Outlets: Install conductor at each outlet, with at least **6 inches (150 mm)** of slack.

80.4 SLEEVE AND SLEEVE-SEAL INSTALLATION FOR ELECTRICAL PENETRATIONS

- A. Install sleeves and sleeve seals at penetrations of exterior floor and wall assemblies. Comply with requirements in Division 26 Section "Sleeves and Sleeve Seals for Electrical Raceways and Cabling."

80.5 FIRESTOPPING

- A. Apply firestopping to electrical penetrations of fire-rated floor and wall assemblies to restore original fire-resistance rating of assembly

80.6 FIELD QUALITY CONTROL

- A. Perform tests and inspections and prepare test reports.
- B. Tests and Inspections:
 - 1. After installing conductors and cables and before electrical circuitry has been energized, test service entrance and feeder conductors for compliance with requirements.
 - 2. Perform each visual and mechanical inspection and electrical test stated in NETA Acceptance Testing Specification. Certify compliance with test parameters.

3. Infrared Scanning: After Substantial Completion, but not more than 60 days after Final Acceptance, perform an infrared scan of each splice in cables and conductors No. 3 AWG and larger. Remove box and equipment covers so splices are accessible to portable scanner.
 - a. Follow-up Infrared Scanning: Perform an additional follow-up infrared scan of each splice 11 months after date of Substantial Completion.
 - b. Instrument: Use an infrared scanning device designed to measure temperature or to detect significant deviations from normal values. Provide calibration record for device.
 - c. Record of Infrared Scanning: Prepare a certified report that identifies splices checked and that describes scanning results. Include notation of deficiencies detected, remedial action taken, and observations after remedial action.
- C. Test Reports: Prepare a written report to record the following:
 1. Test procedures used.
 2. Test results that comply with requirements.
 3. Test results that do not comply with requirements and corrective action taken to achieve compliance with requirements.
- D. Remove and replace malfunctioning units and retest as specified above.
- E. Checking and Testing of Equipment
 1. Switchboards, panelboards, disconnects, and all other operable equipment worked on under this contract shall be inspected for defects, and tested for proper operation.
 2. Systems shall be tested for short circuits, open circuits, wrong connections, and grounds. All system shall be free from mechanical and electrical defects.
 3. Circuits shall be tested for proper neutral and ground connections.
 4. Where required or directed, systems shall be tested in the presence of the Architect to demonstrate that equipment furnished, installed, or connected functions in the manner intended.
 5. The contractor shall furnish all necessary instruments and equipment required for testing and shall immediately correct any defective work at no additional charge. Should the Contractor refuse or neglect to make tests necessary to satisfy the Architect that he has carried out the true intent and meaning of the specifications, the Architect may have such tests made and charge the expense thereof to the Contractor to be retained out of full final payment.

END OF SECTION

SECTION 260526 - GROUNDING AND BONDING FOR ELECTRICAL SYSTEMS

PART 81 - GENERAL

81.1 SUMMARY

- A. Section Includes: Grounding systems and equipment.

81.2 SUBMITTALS

- A. Product Data: For each type of product indicated.
- B. Field quality-control reports.

81.3 QUALITY ASSURANCE

- A. Electrical Components, Devices, and Accessories: Listed and labeled as defined in NFPA 70, by a qualified testing agency, and marked for intended location and application.
- B. Comply with UL 467 for grounding and bonding materials and equipment.

PART 82 - PRODUCTS

82.1 CONDUCTORS

- A. Insulated Conductors: Copper wire or cable insulated for 600 V unless otherwise required by applicable Code or authorities having jurisdiction.
- B. Bare Copper Conductors:
 - 1. Solid Conductors: ASTM B 3.
 - 2. Stranded Conductors: ASTM B 8.
 - 3. Tinned Conductors: ASTM B 33.
 - 4. Bonding Cable: 28 kcmil, 14 strands of No. 17 AWG conductor, 1/4 inch (6 mm) in diameter.
 - 5. Bonding Conductor: No. 4 or No. 6 AWG, stranded conductor.
 - 6. Bonding Jumper: Copper tape, braided conductors terminated with copper ferrules; 1-5/8 inches (41 mm) wide and 1/16 inch (1.6 mm) thick.
 - 7. Tinned Bonding Jumper: Tinned-copper tape, braided conductors terminated with copper ferrules; 1-5/8 inches (41 mm) wide and 1/16 inch (1.6 mm) thick.

82.2 CONNECTORS

- A. Listed and labeled by an NRTL acceptable to authorities having jurisdiction for applications in which used and for specific types, sizes, and combinations of conductors and other items connected.

- B. Bolted Connectors for Conductors and Pipes: Copper or copper alloy, pressure type with at least two bolts.
 - 1. Pipe Connectors: Clamp type, sized for pipe.
- C. Welded Connectors: Exothermic-welding kits of types recommended by kit manufacturer for materials being joined and installation conditions.

82.3 GROUNDING ELECTRODES

- A. Ground Rods: Copper-clad steel, **5/8 by 96 inches (16 by 2400 mm)** in diameter.

PART 83 - EXECUTION

83.1 APPLICATIONS

- A. Conductors: Install solid conductor for No. 8 AWG and smaller, and stranded conductors for No. 6 AWG and larger unless otherwise indicated.
- B. Underground Grounding Conductors: Install bare tinned-copper conductor, No. 3/0 AWG minimum. Bury at least **24 inches (600 mm)** below grade.
- C. Isolated Grounding Conductors: Green-colored insulation with continuous yellow stripe. On feeders with isolated ground, identify grounding conductor where visible to normal inspection, with alternating bands of green and yellow tape, with at least three bands of green and two bands of yellow.
- D. Conductor Terminations and Connections:
 - 1. Pipe and Equipment Grounding Conductor Terminations: Bolted connectors.
 - 2. Underground Connections: Welded connectors except at test wells and as otherwise indicated.
 - 3. Connections to Ground Rods at Test Wells: Bolted connectors.
 - 4. Connections to Structural Steel: Welded connectors.

83.2 EQUIPMENT GROUNDING

- A. Install insulated equipment grounding conductors with the following items, in addition to those required by NFPA 70:
 - 1. Feeders and branch circuits.
 - 2. Lighting circuits.
 - 3. Receptacle circuits.
 - 4. Single-phase motor and appliance branch circuits.
 - 5. Three-phase motor and appliance branch circuits.
 - 6. Flexible raceway runs.
 - 7. Armored and metal-clad cable runs.
 - 8. Busway Supply Circuits: Install insulated equipment grounding conductor from grounding bus in the switchgear, switchboard, or distribution panel to equipment grounding bar terminal on busway.

9. Computer and Rack-Mounted Electronic Equipment Circuits: Install insulated equipment grounding conductor in branch-circuit runs from equipment-area power panels and power-distribution units.
- B. Air-Duct Equipment Circuits: Install insulated equipment grounding conductor to duct-mounted electrical devices operating at 120 V and more, including air cleaners, heaters, dampers, humidifiers, and other duct electrical equipment. Bond conductor to each unit and to air duct and connected metallic piping.
- C. Water Heater, Heat-Tracing, and Antifrost Heating Cables: Install a separate insulated equipment grounding conductor to each electric water heater and heat-tracing cable. Bond conductor to heater units, piping, connected equipment, and components.
- D. Signal and Communication Equipment: In addition to grounding and bonding required by NFPA 70, provide a separate grounding system complying with requirements in TIA/ATIS J-STD-607-A.
 1. For telephone, alarm, voice and data, and other communication equipment, provide No. 4 AWG minimum insulated grounding conductor in raceway from grounding electrode system to each service location, terminal cabinet, wiring closet, and central equipment location.
 2. Service and Central Equipment Locations and Wiring Closets: Terminate grounding conductor on a 1/4-by-4-by-12-inch (6.3-by-100-by-300-mm) grounding bus.
 3. Terminal Cabinets: Terminate grounding conductor on cabinet grounding terminal.
- E. Metal Poles Supporting Outdoor Lighting Fixtures: Install grounding electrode and a separate insulated equipment grounding conductor in addition to grounding conductor installed with branch-circuit conductors.

83.3 INSTALLATION

- A. Grounding Conductors: Route along shortest and straightest paths possible unless otherwise indicated or required by Code. Avoid obstructing access or placing conductors where they may be subjected to strain, impact, or damage.
- B. Ground Rods: Drive rods until tops are 2 inches (50 mm) below finished floor or final grade unless otherwise indicated.
 1. Interconnect ground rods with grounding electrode conductor below grade and as otherwise indicated. Make connections without exposing steel or damaging coating if any.
 2. For grounding electrode system, install at least three rods spaced at least one-rod length from each other and located at least the same distance from other grounding electrodes, and connect to the service grounding electrode conductor.
- C. Test Wells: Ground rod driven through drilled hole in bottom of handhole. Handholes shall be at least 12 inches (300 mm) deep, with cover.
 1. Test Wells: Install at least one test well for each service unless otherwise indicated. Install at the ground rod electrically closest to service entrance. Set top of test well flush with finished grade or floor.

- D. Bonding Straps and Jumpers: Install in locations accessible for inspection and maintenance except where routed through short lengths of conduit.
 - 1. Bonding to Structure: Bond straps directly to basic structure, taking care not to penetrate any adjacent parts.
 - 2. Bonding to Equipment Mounted on Vibration Isolation Hangers and Supports: Install bonding so vibration is not transmitted to rigidly mounted equipment.
 - 3. Use exothermic-welded connectors for outdoor locations; if a disconnect-type connection is required, use a bolted clamp.

- E. Grounding and Bonding for Piping:
 - 1. Metal Water Service Pipe: Install insulated copper grounding conductors, in conduit, from building's main service equipment, or grounding bus, to main metal water service entrances to building. Connect grounding conductors to main metal water service pipes; use a bolted clamp connector or bolt a lug-type connector to a pipe flange using one of the lug bolts of the flange. Where a dielectric main water fitting is installed, connect grounding conductor on street side of fitting. Bond metal grounding conductor conduit or sleeve to conductor at each end.
 - 2. Water Meter Piping: Use braided-type bonding jumpers to electrically bypass water meters. Connect to pipe with a bolted connector.
 - 3. Bond each aboveground portion of gas piping system downstream from equipment shutoff valve.

- F. Bonding Interior Metal Ducts: Bond metal air ducts to equipment grounding conductors of associated fans, blowers, electric heaters, and air cleaners. Install tinned bonding jumper to bond across flexible duct connections to achieve continuity.

83.4 LABELING

- A. Comply with requirements in Division 26 Section "Identification for Electrical Systems" Article for instruction signs. The label or its text shall be green.

- B. Install labels at the telecommunications bonding conductor and grounding equalizer and at the grounding electrode conductor where exposed.
 - 1. Label Text: "If this connector or cable is loose or if it must be removed for any reason, notify the facility manager."

83.5 FIELD QUALITY CONTROL

- A. Perform the following tests and inspections and prepare test reports:
 - 1. After installing grounding system but before permanent electrical circuits have been energized, test for compliance with requirements.
 - 2. Inspect physical and mechanical condition. Verify tightness of accessible, bolted, electrical connections with a calibrated torque wrench according to manufacturer's written instructions.
 - 3. Test completed grounding system at each location where a maximum ground-resistance level is specified, at service disconnect enclosure grounding terminal, and at ground test wells. Make tests at ground rods before any conductors are connected.

- B. Report measured ground resistances that exceed the following values:
1. Power and Lighting Equipment or System with Capacity of 500 kVA and Less: 10 ohms.
 2. Power and Lighting Equipment or System with Capacity of 500 to 1000 kVA: 5 ohms.
 3. Power and Lighting Equipment or System with Capacity More Than 1000 kVA: 3 ohms.
 4. Power Distribution Units or Panelboards Serving Electronic Equipment: 3 ohm(s).
- C. Excessive Ground Resistance: If resistance to ground exceeds specified values, notify Architect promptly and include recommendations to reduce ground resistance.

END OF SECTION

SECTION 260529 - HANGERS AND SUPPORTS FOR ELECTRICAL SYSTEMS

PART 84 - GENERAL

84.1 SUMMARY

- A. Section includes:
 - 1. Hangers and supports for electrical equipment and systems.
 - 2. Construction requirements for concrete bases.

84.2 PERFORMANCE REQUIREMENTS

- A. Delegated Design: Design supports for multiple raceways, including comprehensive engineering analysis by a qualified professional engineer, using performance requirements and design criteria indicated.
- B. Design supports for multiple raceways capable of supporting combined weight of supported systems and its contents.
- C. Design equipment supports capable of supporting combined operating weight of supported equipment and connected systems and components.
- D. Rated Strength: Adequate in tension, shear, and pullout force to resist maximum loads calculated or imposed for this Project, with a minimum structural safety factor of five times the applied force.

84.3 SUBMITTALS

- A. Product Data: For steel slotted support systems.
- B. Shop Drawings: Show fabrication and installation details and include calculations for the following:
 - 1. Trapeze hangers. Include Product Data for components.
 - 2. Steel slotted channel systems. Include Product Data for components.
 - 3. Equipment supports.
- C. Welding certificates.

84.4 QUALITY ASSURANCE

- A. Welding: Qualify procedures and personnel according to AWS D1.1/D1.1M, "Structural Welding Code - Steel."
- B. Comply with NFPA 70.

PART 85 - PRODUCTS

85.1 SUPPORT, ANCHORAGE, AND ATTACHMENT COMPONENTS

- A. Steel Slotted Support Systems: Comply with MFMA-4, factory-fabricated components for field assembly.
 - 1. Available Manufacturers: Subject to compliance with requirements, manufacturers offering products that may be incorporated into the Work include, but are not limited to, the following:
 - a. Allied Tube & Conduit.
 - b. Cooper B-Line, Inc.; a division of Cooper Industries.
 - c. ERICO International Corporation.
 - d. GS Metals Corp.
 - e. Thomas & Betts Corporation.
 - f. Unistrut; Tyco International, Ltd.
 - g. Wesanco, Inc.
 - 2. Metallic Coatings: Hot-dip galvanized after fabrication and applied according to MFMA-4.
 - 3. Nonmetallic Coatings: Manufacturer's standard PVC, polyurethane, or polyester coating applied according to MFMA-4.
 - 4. Painted Coatings: Manufacturer's standard painted coating applied according to MFMA-4.
 - 5. Channel Dimensions: Selected for applicable load criteria.
- B. Raceway and Cable Supports: As described in NECA 1 and NECA 101.
- C. Conduit and Cable Support Devices: Steel hangers, clamps, and associated fittings, designed for types and sizes of raceway or cable to be supported.
- D. Support for Conductors in Vertical Conduit: Factory-fabricated assembly consisting of threaded body and insulating wedging plug or plugs for non-armored electrical conductors or cables in riser conduits. Plugs shall have number, size, and shape of conductor gripping pieces as required to suit individual conductors or cables supported. Body shall be malleable iron.
- E. Structural Steel for Fabricated Supports and Restraints: ASTM A 36/A 36M, steel plates, shapes, and bars; black and galvanized.
- F. Mounting, Anchoring, and Attachment Components: Items for fastening electrical items or their supports to building surfaces include the following:
 - 1. Mechanical-Expansion Anchors: Insert-wedge-type, zinc-coated steel, for use in hardened portland cement concrete with tension, shear, and pullout capacities appropriate for supported loads and building materials in which used.
 - a. Available Manufacturers: Subject to compliance with requirements, manufacturers offering products that may be incorporated into the Work include, but are not limited to, the following:
 - 1) Cooper B-Line, Inc.; a division of Cooper Industries.

- 2) Empire Tool and Manufacturing Co., Inc.
 - 3) Hilti Inc.
 - 4) ITW Ramset/Red Head; a division of Illinois Tool Works, Inc.
 - 5) MKT Fastening, LLC.
2. Concrete Inserts: Steel or malleable-iron, slotted support system units similar to MSS Type 18; complying with MFMA-4 or MSS SP-58.
 3. Clamps for Attachment to Steel Structural Elements: MSS SP-58, type suitable for attached structural element.
 4. Through Bolts: Structural type, hex head, and high strength. Comply with ASTM A 325.
 5. Toggle Bolts: All-steel springhead type.
 6. Hanger Rods: Threaded steel.

85.2 FABRICATED METAL EQUIPMENT SUPPORT ASSEMBLIES

- A. Description: Welded or bolted, structural-steel shapes, shop or field fabricated to fit dimensions of supported equipment.
- B. Materials: Comply with requirements in Division 05 Section "Metal Fabrications" for steel shapes and plates.

PART 86 - EXECUTION

86.1 APPLICATION

- A. Comply with NECA 1 and NECA 101 for application of hangers and supports for electrical equipment and systems except if requirements in this Section are stricter.
- B. Maximum Support Spacing and Minimum Hanger Rod Size for Raceway: Space supports for EMT, IMC, and RMC as scheduled in NECA 1, where its Table 1 lists maximum spacings less than stated in NFPA 70. Minimum rod size shall be **1/4 inch (6 mm)** in diameter.
- C. Multiple Raceways or Cables: Install trapeze-type supports fabricated with steel slotted support system, sized so capacity can be increased by at least 25 percent in future without exceeding specified design load limits.
 1. Secure raceways and cables to these supports with two-bolt conduit clamps or single-bolt conduit clamps.
- D. Spring-steel clamps designed for supporting single conduits without bolts may be used for **1-1/2-inch (38-mm)** and smaller raceways serving branch circuits and communication systems above suspended ceilings and for fastening raceways to trapeze supports.

86.2 SUPPORT INSTALLATION

- A. Comply with NECA 1 and NECA 101 for installation requirements except as specified in this Article.

- B. Raceway Support Methods: In addition to methods described in NECA 1, EMT, IMC, and RMC may be supported by openings through structure members, as permitted in NFPA 70.
- C. Strength of Support Assemblies: Where not indicated, select sizes of components so strength will be adequate to carry present and future static loads within specified loading limits. Minimum static design load used for strength determination shall be weight of supported components plus 200 lb (90 kg).
- D. Mounting and Anchorage of Surface-Mounted Equipment and Components: Anchor and fasten electrical items and their supports to building structural elements by the following methods unless otherwise indicated by code:
 - 1. To Wood: Fasten with lag screws or through bolts.
 - 2. To New Concrete: Bolt to concrete inserts.
 - 3. To Masonry: Approved toggle-type bolts on hollow masonry units and expansion anchor fasteners on solid masonry units.
 - 4. To Existing Concrete: Expansion anchor fasteners.
 - 5. Instead of expansion anchors, powder-actuated driven threaded studs provided with lock washers and nuts may be used in existing standard-weight concrete 4 inches (100 mm) thick or greater. Do not use for anchorage to lightweight-aggregate concrete or for slabs less than 4 inches (100 mm) thick.
 - 6. To Steel: Beam clamps (MSS Type 19, 21, 23, 25, or 27) complying with MSS SP-69 or Spring-tension clamps.
 - 7. To Light Steel: Sheet metal screws.
 - 8. Items Mounted on Hollow Walls and Nonstructural Building Surfaces: Mount cabinets, panelboards, disconnect switches, control enclosures, pull and junction boxes, transformers, and other devices on slotted-channel racks attached to substrate by means that meet seismic-restraint strength and anchorage requirements.
- E. Drill holes for expansion anchors in concrete at locations and to depths that avoid reinforcing bars.

86.3 INSTALLATION OF FABRICATED METAL SUPPORTS

- A. Comply with installation requirements in Division 05 Section "Metal Fabrications" for site-fabricated metal supports.
- B. Cut, fit, and place miscellaneous metal supports accurately in location, alignment, and elevation to support and anchor electrical materials and equipment.
- C. Field Welding: Comply with AWS D1.1/D1.1M.

86.4 CONCRETE BASES

- A. Construct concrete bases of dimensions indicated but not less than 4 inches (100 mm) larger in both directions than supported unit, and so anchors will be a minimum of 10 bolt diameters from edge of the base.
- B. Use 3000-psi (20.7-MPa), 28-day compressive-strength concrete. Concrete materials, reinforcement, and placement requirements are specified in Section 033000 "Cast-in-place Concrete."

- C. Anchor equipment to concrete base.
 - 1. Place and secure anchorage devices. Use supported equipment manufacturer's setting drawings, templates, diagrams, instructions, and directions furnished with items to be embedded.
 - 2. Install anchor bolts to elevations required for proper attachment to supported equipment.
 - 3. Install anchor bolts according to anchor-bolt manufacturer's written instructions.

86.5 PAINTING

- A. Touchup: Clean field welds and abraded areas of shop paint. Paint exposed areas immediately after erecting hangers and supports. Use same materials as used for shop painting. Comply with SSPC-PA 1 requirements for touching up field-painted surfaces.
 - 1. Apply paint by brush or spray to provide minimum dry film thickness of 2.0 mils (0.05 mm).
- B. Touchup: Comply with requirements in Division 09 painting Sections for cleaning and touchup painting of field welds, bolted connections, and abraded areas of shop paint on miscellaneous metal.
- C. Galvanized Surfaces: Clean welds, bolted connections, and abraded areas and apply galvanizing-repair paint to comply with ASTM A 780.

END OF SECTION

SECTION 260533 - RACEWAY AND BOXES FOR ELECTRICAL SYSTEMS

PART 87 - GENERAL

87.1 SUMMARY

- A. This Section includes raceways, fittings, boxes, enclosures, and cabinets for electrical wiring.
- B. See Division 26 Section "Raceways and Boxes for Electrical Systems" for exterior ductbanks and manholes, and underground handholes, boxes, and utility construction.

87.2 SUBMITTALS

- A. Product Data: For surface raceways, wireways and fittings, floor boxes, hinged-cover enclosures, and cabinets.
- B. Shop Drawings: For custom enclosures and cabinets. Include plans, elevations, sections, details, and attachments to other work.

87.3 QUALITY ASSURANCE

- A. Electrical Components, Devices, and Accessories: Listed and labeled as defined in NFPA 70, Article 100, by a testing agency acceptable to authorities having jurisdiction, and marked for intended use.
- B. Comply with NFPA 70.

PART 88 - PRODUCTS

88.1 METAL CONDUIT AND TUBING

- A. Rigid Steel Conduit: ANSI C80.1.
- B. IMC: ANSI C80.6.
- C. EMT: ANSI C80.3.
- D. FMC: Zinc-coated steel.
- E. LFMC: Flexible steel conduit with PVC jacket.
- F. Fittings for Conduit (Including all Types and Flexible and Liquidtight), EMT, and Cable: NEMA FB 1; listed for type and size raceway with which used, and for application and environment in which installed.
 - 1. Conduit Fittings for Hazardous (Classified) Locations: Comply with UL 886.

2. Fittings for EMT: Steel or die-cast, compression type.

88.2 NONMETALLIC CONDUIT AND TUBING

- A. ENT: NEMA TC 13.
- B. RNC: NEMA TC 2, Type EPC-40-PVC, unless otherwise indicated.
- C. LFNC: UL 1660.
- D. Fittings for ENT and RNC: NEMA TC 3; match to conduit or tubing type and material.
- E. Fittings for LFNC: UL 514B.

88.3 METAL WIREWAYS

- A. Available Manufacturers: Subject to compliance with requirements, manufacturers offering products that may be incorporated into the Work include, but are not limited to, the following:
 1. Cooper B-Line, Inc.
 2. Hoffman.
 3. Square D; Schneider Electric.
- B. Description: Sheet metal sized and shaped as indicated, NEMA 250, Type 1, 12, 3R or 4X stainless steel, unless otherwise indicated.
- C. Fittings and Accessories: Include couplings, offsets, elbows, expansion joints, adapters, hold-down straps, end caps, and other fittings to match and mate with wireways as required for complete system.
- D. Wireway Covers: As indicated.
- E. Finish: Manufacturer's standard enamel finish.

88.4 NONMETALLIC WIREWAYS

- A. Available Manufacturers: Subject to compliance with requirements, manufacturers offering products that may be incorporated into the Work include, but are not limited to, the following:
 1. Hoffman.
 2. Lamson & Sessions; Carlon Electrical Products.
- B. Description: PVC plastic, extruded and fabricated to size and shape indicated, with snap-on cover and mechanically coupled connections with plastic fasteners.
- C. Fittings and Accessories: Include couplings, offsets, elbows, expansion joints, adapters, hold-down straps, end caps, and other fittings to match and mate with wireways as required for complete system.

88.5 BOXES, ENCLOSURES, AND CABINETS

- A. Sheet Metal Outlet and Device Boxes: NEMA OS 1.
- B. Cast-Metal Outlet and Device Boxes: NEMA FB 1, ferrous alloy, Type FD, with gasketed cover.
- C. Nonmetallic Outlet and Device Boxes: NEMA OS 2.
- D. Metal Floor Boxes: Cast metal, fully adjustable, rectangular.
- E. Nonmetallic Floor Boxes: Nonadjustable, round.
- F. Small Sheet Metal Pull and Junction Boxes: NEMA OS 1.
- G. Cast-Metal Access, Pull, and Junction Boxes: NEMA FB 1, galvanized, cast iron with gasketed cover.
- H. Hinged-Cover Enclosures: NEMA 250, Type 1, with continuous-hinge cover with flush latch, unless otherwise indicated.
 - 1. Metal Enclosures: Steel, finished inside and out with manufacturer's standard enamel.
 - 2. Nonmetallic Enclosures: Plastic, finished inside with radio-frequency-resistant paint.
- I. Cabinets:
 - 1. NEMA 250, Type 1, galvanized-steel box with removable interior panel and removable front, finished inside and out with manufacturer's standard enamel.
 - 2. Hinged door in front cover with flush latch and concealed hinge.
 - 3. Key latch to match panelboards.
 - 4. Metal barriers to separate wiring of different systems and voltage.
 - 5. Accessory feet where required for freestanding equipment.

PART 89 - EXECUTION

89.1 RACEWAY APPLICATION

- A. Outdoors: Apply raceway products as specified below, unless otherwise indicated:
 - 1. Exposed Conduit: Rigid steel conduit.
 - 2. Concealed Conduit, Aboveground: Rigid steel conduit, IMC, EMT.
 - 3. Underground Conduit: RNC, Type EPC-40-PVC, direct buried.
 - 4. Connection to Vibrating Equipment (Including Transformers and Hydraulic, Pneumatic, Electric Solenoid, or Motor-Driven Equipment): LFMC.
 - 5. Boxes and Enclosures, Aboveground: NEMA 250, Type 4X Stainless steel.
- B. Comply with the following indoor applications, unless otherwise indicated:
 - 1. Exposed, Not Subject to Physical Damage: EMT.
 - 2. Exposed, Not Subject to Severe Physical Damage: EMT.

3. Exposed and Subject to Severe Physical Damage: Rigid steel conduit. Includes raceways in the following locations:
 - a. Loading dock.
 - b. Corridors used for traffic of mechanized carts, forklifts, and pallet-handling units.
 - c. Mechanical rooms.
 4. Concealed in Ceilings and Interior Walls and Partitions: EMT.
 5. Connection to Vibrating Equipment (Including Transformers and Hydraulic, Pneumatic, Electric Solenoid, or Motor-Driven Equipment): FMC, except use LFMC in damp or wet locations.
 6. Damp or Wet Locations: Rigid steel conduit.
 7. Raceways for Optical Fiber or Communications Cable: EMT.
 8. Boxes and Enclosures: NEMA 250, Type 1, except use NEMA 250, Type 4X, stainless steel in damp or wet locations.
- C. Minimum Raceway Size: **3/4-inch (21-mm)** trade size.
- D. Raceway Fittings: Compatible with raceways and suitable for use and location.
1. Rigid and Intermediate Steel Conduit: Use threaded rigid steel conduit fittings, unless otherwise indicated.

89.2 INSTALLATION

- A. Comply with NECA 1 for installation requirements applicable to products specified in Part 2 except where requirements on Drawings or in this Article are stricter.
- B. Keep raceways at least **6 inches (150 mm)** away from parallel runs of flues and steam or hot-water pipes. Install horizontal raceway runs above water and steam piping.
- C. Complete raceway installation before starting conductor installation.
- D. Support raceways as specified in Division 26 Section "Hangers and Supports for Electrical Systems."
- E. Arrange stub-ups so curved portions of bends are not visible above the finished slab.
- F. Install no more than the equivalent of three 90-degree bends in any conduit run except for communications conduits, for which fewer bends are allowed.
- G. Conceal conduit and EMT within finished walls, ceilings, and floors, unless otherwise indicated.
- H. Raceways Embedded in Slabs:
 1. Run conduit larger than **1-inch (27-mm)** trade size, parallel or at right angles to main reinforcement. Where at right angles to reinforcement, place conduit close to slab support.
 2. Arrange raceways to cross building expansion joints at right angles with expansion fittings.

3. Change from ENT to RNC, Type EPC-40-PVC, rigid steel conduit, or IMC before rising above the floor.
- I. Raceway Terminations at Locations Subject to Moisture or Vibration: Use insulating bushings to protect conductors, including conductors smaller than No. 4 AWG.
 - J. Install pull wires in empty raceways. Use polypropylene or monofilament plastic line with not less than **200-lb (90-kg)** tensile strength. Leave at least **12 inches (300 mm)** of slack at each end of pull wire.
 - K. Raceways for Optical Fiber and Communications Cable: Install as follows:
 1. **3/4-Inch (19-mm)** Trade Size and Smaller: Install raceways in maximum lengths of **50 feet (15 m)**.
 2. **1-Inch (25-mm)** Trade Size and Larger: Install raceways in maximum lengths of **75 feet (23 m)**.
 3. Install with a maximum of two 90-degree bends or equivalent for each length of raceway unless Drawings show stricter requirements. Separate lengths with pull or junction boxes or terminations at distribution frames or cabinets where necessary to comply with these requirements.
 - L. Install raceway sealing fittings at suitable, approved, and accessible locations and fill them with listed sealing compound. For concealed raceways, install each fitting in a flush steel box with a blank cover plate having a finish similar to that of adjacent plates or surfaces. Install raceway sealing fittings at the following points:
 1. Where conduits pass from warm to cold locations, such as boundaries of refrigerated spaces.
 2. Where otherwise required by NFPA 70.
 - M. Expansion-Joint Fittings for RNC: Install in each run of aboveground conduit that is located where environmental temperature change may exceed **30 deg F (17 deg C)**, and that has straight-run length that exceeds **25 feet (7.6 m)**.
 1. Install expansion-joint fittings for each of the following locations, and provide type and quantity of fittings that accommodate temperature change listed for location:
 - a. Outdoor Locations Not Exposed to Direct Sunlight: **125 deg F (70 deg C)** temperature change.
 - b. Outdoor Locations Exposed to Direct Sunlight: **155 deg F (86 deg C)** temperature change.
 - c. Indoor Spaces: Connected with the Outdoors without Physical Separation: **125 deg F (70 deg C)** temperature change.
 - d. Attics: **135 deg F (75 deg C)** temperature change.
 2. Install fitting(s) that provide expansion and contraction for at least **0.00041 inch per foot of length of straight run per deg F (0.06 mm per meter of length of straight run per deg C)** of temperature change.
 3. Install each expansion-joint fitting with position, mounting, and piston setting selected according to manufacturer's written instructions for conditions at specific location at the time of installation.

- N. Flexible Conduit Connections: Use maximum of **72 inches (1830 mm)** of flexible conduit for recessed and semirecessed lighting fixtures, equipment subject to vibration, noise transmission, or movement; and for transformers and motors.
 - 1. Use LFMC in damp or wet locations subject to severe physical damage.
 - 2. Use LFMC in damp or wet locations not subject to severe physical damage.
- O. Recessed Boxes in Masonry Walls: Saw-cut opening for box in center of cell of masonry block, and install box flush with surface of wall.
- P. Set metal floor boxes level and flush with finished floor surface.
- Q. Set nonmetallic floor boxes level. Trim after installation to fit flush with finished floor surface.

89.3 INSTALLATION OF UNDERGROUND CONDUIT

- A. Direct-Buried Conduit:
 - 1. Excavate trench bottom to provide firm and uniform support for conduit. Prepare trench bottom as specified in Greenbook Section 300 "Earth Moving" for pipe less than **6 inches (150 mm)** in nominal diameter.
 - 2. Install backfill as specified in Greenbook Section 300 "Earth Moving."
 - 3. After installing conduit, backfill and compact. Start at tie-in point, and work toward end of conduit run, leaving conduit at end of run free to move with expansion and contraction as temperature changes during this process. Firmly hand tamp backfill around conduit to provide maximum supporting strength. After placing controlled backfill to within **12 inches (300 mm)** of finished grade, make final conduit connection at end of run and complete backfilling with normal compaction as specified in Greenbook Section 300 "Earth Moving."
 - 4. Install manufactured duct elbows for stub-ups at poles and equipment and at building entrances through the floor, unless otherwise indicated. Encase elbows for stub-up ducts throughout the length of the elbow.
 - 5. Install manufactured rigid steel conduit elbows for stub-ups at poles and equipment and at building entrances through the floor.
 - a. Couple steel conduits to ducts with adapters designed for this purpose, and encase coupling with **3 inches (75 mm)** of concrete.
 - b. For stub-ups at equipment mounted on outdoor concrete bases, extend steel conduit horizontally a minimum of **60 inches (1500 mm)** from edge of equipment pad or foundation. Install insulated grounding bushings on terminations at equipment.
 - 6. Warning Planks: Bury warning planks approximately **12 inches (300 mm)** above direct-buried conduits, placing them **24 inches (600 mm)** o.c. Align planks along the width and along the centerline of conduit.

89.4 FIRESTOPPING

- A. Apply firestopping to electrical penetrations of fire-rated floor and wall assemblies to restore original fire-resistance rating of assembly.

END OF SECTION

SECTION 260544 - SLEEVES AND SLEEVE SEALS FOR ELECTRICAL RACEWAYS AND CABLING

PART 90 - GENERAL

90.1 SUMMARY

A. Section Includes:

1. Sleeves for raceway and cable penetration of non-fire-rated construction walls and floors.
2. Sleeve-seal systems.
3. Sleeve-seal fittings.
4. Grout.
5. Silicone sealants.

90.2 ACTION SUBMITTALS

- ##### A. Product Data: For each type of product.

PART 91 - PRODUCTS

91.1 SLEEVES

A. Wall Sleeves:

1. Steel Pipe Sleeves: ASTM A 53/A 53M, Type E, Grade B, Schedule 40, zinc coated, plain ends.
2. Cast-Iron Pipe Sleeves: Cast or fabricated "wall pipe," equivalent to ductile-iron pressure pipe, with plain ends and integral waterstop unless otherwise indicated.

- ##### B. Sleeves for Conduits Penetrating Non-Fire-Rated Gypsum Board Assemblies: Galvanized-steel sheet; 0.0239-inch (0.6-mm) minimum thickness; round tube closed with welded longitudinal joint, with tabs for screw-fastening the sleeve to the board.

C. Sleeves for Rectangular Openings:

1. Material: Galvanized sheet steel.
2. Minimum Metal Thickness:
 - a. For sleeve cross-section rectangle perimeter less than 50 inches (1270 mm) and with no side larger than 16 inches (400 mm), thickness shall be 0.052 inch (1.3 mm).
 - b. For sleeve cross-section rectangle perimeter 50 inches (1270 mm) or more and one or more sides larger than 16 inches (400 mm), thickness shall be 0.138 inch (3.5 mm).

91.2 SLEEVE-SEAL SYSTEMS

- A. Description: Modular sealing device, designed for field assembly, to fill annular space between sleeve and raceway or cable.
1. Manufacturers: Subject to compliance with requirements, available manufacturers offering products that may be incorporated into the Work include, but are not limited to, the following:
 - a. Advance Products & Systems, Inc.
 - b. CALPICO, Inc.
 - c. Metraflex Company (The).
 - d. Pipeline Seal and Insulator, Inc.
 - e. Proco Products, Inc.
 2. Sealing Elements: EPDM rubber interlocking links shaped to fit surface of pipe. Include type and number required for pipe material and size of pipe.
 3. Pressure Plates: Carbon steel.
 4. Connecting Bolts and Nuts: Carbon steel, with corrosion-resistant coating, of length required to secure pressure plates to sealing elements.

91.3 SLEEVE-SEAL FITTINGS

- A. Description: Manufactured plastic, sleeve-type, waterstop assembly made for embedding in concrete slab or wall. Unit shall have plastic or rubber waterstop collar with center opening to match piping OD.
1. Manufacturers: Subject to compliance with requirements, provide products by the following:
 - a. Presealed Systems.

91.4 GROUT

- A. Description: Nonshrink; recommended for interior and exterior sealing openings in non-fire-rated walls or floors.
- B. Standard: ASTM C 1107/C 1107M, Grade B, post-hardening and volume-adjusting, dry, hydraulic-cement grout.
- C. Design Mix: 5000-psi (34.5-MPa), 28-day compressive strength.
- D. Packaging: Premixed and factory packaged.

91.5 SILICONE SEALANTS

- A. Silicone Sealants: Single-component, silicone-based, neutral-curing elastomeric sealants of grade indicated below.
1. Grade: Pourable (self-leveling) formulation for openings in floors and other horizontal surfaces that are not fire rated.
 2. Sealant shall have VOC content of 250 g/L or less when calculated according to 40 CFR 59, Subpart D (EPA Method 24).

3. Sealant shall comply with the testing and product requirements of the California Department of Health Services' "Standard Practice for the Testing of Volatile Organic Emissions from Various Sources Using Small-Scale Environmental Chambers."
- B. Silicone Foams: Multicomponent, silicone-based liquid elastomers that, when mixed, expand and cure in place to produce a flexible, nonshrinking foam.

PART 92 - EXECUTION

92.1 SLEEVE INSTALLATION FOR NON-FIRE-RATED ELECTRICAL PENETRATIONS

- A. Comply with NECA 1.
- B. Comply with NEMA VE 2 for cable tray and cable penetrations.
- C. Sleeves for Conduits Penetrating Above-Grade Non-Fire-Rated Concrete and Masonry-Unit Floors and Walls:
 1. Interior Penetrations of Non-Fire-Rated Walls and Floors:
 - a. Seal annular space between sleeve and raceway or cable, using joint sealant appropriate for size, depth, and location of joint. Comply with requirements in Division 07 Section "Joint Sealants."
 - b. Seal space outside of sleeves with mortar or grout. Pack sealing material solidly between sleeve and wall so no voids remain. Tool exposed surfaces smooth; protect material while curing.
 2. Use pipe sleeves unless penetration arrangement requires rectangular sleeved opening.
 3. Size pipe sleeves to provide **1/4-inch (6.4-mm)** annular clear space between sleeve and raceway or cable unless sleeve seal is to be installed or unless seismic criteria require different clearance.
 4. Install sleeves for wall penetrations unless core-drilled holes or formed openings are used. Install sleeves during erection of walls. Cut sleeves to length for mounting flush with both surfaces of walls. Deburr after cutting.
 5. Install sleeves for floor penetrations. Extend sleeves installed in floors **2 inches (50 mm)** above finished floor level. Install sleeves during erection of floors.
- D. Sleeves for Conduits Penetrating Non-Fire-Rated Gypsum Board Assemblies:
 1. Use circular metal sleeves unless penetration arrangement requires rectangular sleeved opening.
 2. Seal space outside of sleeves with approved joint compound for gypsum board assemblies.
- E. Roof-Penetration Sleeves: Seal penetration of individual raceways and cables with flexible boot-type flashing units applied in coordination with roofing work.
- F. Aboveground, Exterior-Wall Penetrations: Seal penetrations using steel pipe sleeves and mechanical sleeve seals. Select sleeve size to allow for **1-inch (25-mm)** annular clear space between pipe and sleeve for installing mechanical sleeve seals.
- G. Underground, Exterior-Wall and Floor Penetrations: Install cast-iron pipe sleeves. Size sleeves to allow for **1-inch (25-mm)** annular clear space between raceway or cable and sleeve for installing sleeve-seal system.

92.2 SLEEVE-SEAL-SYSTEM INSTALLATION

- A. Install sleeve-seal systems in sleeves in exterior concrete walls and slabs-on-grade at raceway entries into building.
- B. Install type and number of sealing elements recommended by manufacturer for raceway or cable material and size. Position raceway or cable in center of sleeve. Assemble mechanical sleeve seals and install in annular space between raceway or cable and sleeve. Tighten bolts against pressure plates that cause sealing elements to expand and make watertight seal.

92.3 SLEEVE-SEAL-FITTING INSTALLATION

- A. Install sleeve-seal fittings in new walls and slabs as they are constructed.
- B. Assemble fitting components of length to be flush with both surfaces of concrete slabs and walls. Position waterstop flange to be centered in concrete slab or wall.
- C. Secure nailing flanges to concrete forms.
- D. Using grout, seal the space around outside of sleeve-seal fittings.

END OF SECTION

SECTION 260548 - VIBRATION AND SEISMIC CONTROLS FOR ELECTRICAL SYSTEMS

PART 93 - GENERAL

93.1 SUMMARY

- A. Section includes:
1. Isolation pads.
 2. Spring isolators.
 3. Restrained spring isolators.
 4. Channel support systems.
 5. Restraint cables.
 6. Hanger rod stiffeners.
 7. Anchorage bushings and washers.

93.2 PERFORMANCE REQUIREMENTS

- A. Seismic-Restraint Loading:
1. Site Class as Defined in the IBC: D.
 2. Assigned Seismic Use Group or Building Category as Defined in the IBC: II.
 - a. Component Importance Factor: 1.0.
 - b. Component Response Modification Factor: 1.5.
 - c. Component Amplification Factor: 1.0.

93.3 SUBMITTALS

- A. Product Data: For the following:
1. Include rated load, rated deflection, and overload capacity for each vibration isolation device.
 2. Illustrate and indicate style, material, strength, fastening provision, and finish for each type and size of seismic-restraint component used.
 - a. Tabulate types and sizes of seismic restraints, complete with report numbers and rated strength in tension and shear as evaluated by an agency acceptable to authorities having jurisdiction.
 - b. Annotate to indicate application of each product submitted and compliance with requirements.
 3. Restrained-Isolation Devices: Include ratings for horizontal, vertical, and combined loads.
- B. Delegated-Design Submittal: For vibration isolation and seismic-restraint details indicated to comply with performance requirements and design criteria, including analysis data signed and sealed by the qualified professional engineer responsible for their preparation.
1. Design Calculations: Calculate static and dynamic loading due to equipment weight and operation, seismic forces required to select vibration isolators and seismic restraints.

- a. Coordinate design calculations with wind-load calculations required for equipment mounted outdoors. Comply with requirements in other Division 26 Sections for equipment mounted outdoors.
- 2. Indicate materials and dimensions and identify hardware, including attachment and anchorage devices.
- 3. Field-fabricated supports.
- 4. Seismic-Restraint Details:
 - a. Design Analysis: To support selection and arrangement of seismic restraints. Include calculations of combined tensile and shear loads.
 - b. Details: Indicate fabrication and arrangement. Detail attachments of restraints to the restrained items and to the structure. Show attachment locations, methods, and spacings. Identify components, list their strengths, and indicate directions and values of forces transmitted to the structure during seismic events.
 - c. Preapproval and Evaluation Documentation: By an agency acceptable to authorities having jurisdiction, showing maximum ratings of restraint items and the basis for approval (tests or calculations).
- C. Welding certificates.
- D. Field quality-control test reports.

93.4 QUALITY ASSURANCE

- A. Comply with seismic-restraint requirements in the IBC unless requirements in this Section are more stringent.
- B. Welding Qualifications: Qualify procedures and personnel according to AWS D1.1/D1.1M, "Structural Welding Code - Steel."
- C. Seismic-restraint devices shall have horizontal and vertical load testing and analysis and shall bear anchorage preapproval OPA number from OSHPD, preapproval by ICC-ES, or preapproval by another agency acceptable to authorities having jurisdiction, showing maximum seismic-restraint ratings. Ratings based on independent testing are preferred to ratings based on calculations. If preapproved ratings are not available, submittals based on independent testing are preferred. Calculations (including combining shear and tensile loads) to support seismic-restraint designs must be signed and sealed by a qualified professional engineer.
- D. Comply with NFPA 70.

PART 94 - PRODUCTS

94.1 VIBRATION ISOLATORS

- A. Available Manufacturers: Subject to compliance with requirements, manufacturers offering products that may be incorporated into the Work include, but are not limited to, the following:
 - 1. Ace Mountings Co., Inc.
 - 2. Amber/Booth Company, Inc.
 - 3. California Dynamics Corporation.
 - 4. Isolation Technology, Inc.
 - 5. Kinetics Noise Control.

6. Mason Industries.
 7. Vibration Eliminator Co., Inc.
 8. Vibration Isolation.
 9. Vibration Mountings & Controls, Inc.
- B. Pads: Arrange in single or multiple layers of sufficient stiffness for uniform loading over pad area, molded with a nonslip pattern and galvanized-steel baseplates, and factory cut to sizes that match requirements of supported equipment.
1. Resilient Material: Oil- and water-resistant neoprene.
- C. Spring Isolators: Freestanding, laterally stable, open-spring isolators.
1. Outside Spring Diameter: Not less than 80 percent of the compressed height of the spring at rated load.
 2. Minimum Additional Travel: 50 percent of the required deflection at rated load.
 3. Lateral Stiffness: More than 80 percent of rated vertical stiffness.
 4. Overload Capacity: Support 200 percent of rated load, fully compressed, without deformation or failure.
 5. Baseplates: Factory drilled for bolting to structure and bonded to **1/4-inch- (6-mm-)** thick, rubber isolator pad attached to baseplate underside. Baseplates shall limit floor load to **500 psig (3447 kPa)**.
 6. Top Plate and Adjustment Bolt: Threaded top plate with adjustment bolt and cap screw to fasten and level equipment.
- D. Restrained Spring Isolators: Freestanding, steel, open-spring isolators with seismic or limit-stop restraint.
1. Housing: Steel with resilient vertical-limit stops to prevent spring extension due to weight being removed; factory-drilled baseplate bonded to **1/4-inch- (6-mm-)** thick, neoprene or rubber isolator pad attached to baseplate underside; and adjustable equipment mounting and leveling bolt that acts as blocking during installation.
 2. Restraint: Seismic or limit-stop as required for equipment and authorities having jurisdiction.
 3. Outside Spring Diameter: Not less than 80 percent of the compressed height of the spring at rated load.
 4. Minimum Additional Travel: 50 percent of the required deflection at rated load.
 5. Lateral Stiffness: More than 80 percent of rated vertical stiffness.
 6. Overload Capacity: Support 200 percent of rated load, fully compressed, without deformation or failure.

94.2 SEISMIC-RESTRAINT DEVICES

- A. Available Manufacturers: Subject to compliance with requirements, manufacturers offering products that may be incorporated into the Work include, but are not limited to, the following:
1. Amber/Booth Company, Inc.
 2. California Dynamics Corporation.
 3. Cooper B-Line, Inc.; a division of Cooper Industries.
 4. Hilti Inc.
 5. Loos & Co.; Seismic Earthquake Division.
 6. Mason Industries.
 7. TOLCO Incorporated; a brand of NIBCO INC.
 8. Unistrut; Tyco International, Ltd.

- B. General Requirements for Restraint Components: Rated strengths, features, and application requirements shall be as defined in reports by an agency acceptable to authorities having jurisdiction.
 - 1. Structural Safety Factor: Allowable strength in tension, shear, and pullout force of components shall be at least four times the maximum seismic forces to which they will be subjected.
- C. Channel Support System: MFMA-3, shop- or field-fabricated support assembly made of slotted steel channels with accessories for attachment to braced component at one end and to building structure at the other end and other matching components and with corrosion-resistant coating; and rated in tension, compression, and torsion forces.
- D. Restraint Cables: ASTM A 603 galvanized-steel cables with end connections made of steel assemblies with thimbles, brackets, swivels, and bolts designed for restraining cable service; and with a minimum of two clamping bolts for cable engagement.
- E. Hanger Rod Stiffener: Steel tube or steel slotted-support-system sleeve with internally bolted connections to hanger rod. Do not weld stiffeners to rods.
- F. Bushings for Floor-Mounted Equipment Anchor: Neoprene bushings designed for rigid equipment mountings, and matched to type and size of anchors and studs.
- G. Bushing Assemblies for Wall-Mounted Equipment Anchorage: Assemblies of neoprene elements and steel sleeves designed for rigid equipment mountings, and matched to type and size of attachment devices.
- H. Resilient Isolation Washers and Bushings: One-piece, molded, oil- and water-resistant neoprene, with a flat washer face.
- I. Mechanical Anchor: Drilled-in and stud-wedge or female-wedge type in zinc-coated steel for interior applications and stainless steel for exterior applications. Select anchors with strength required for anchor and as tested according to ASTM E 488. Minimum length of eight times diameter.
- J. Adhesive Anchor: Drilled-in and capsule anchor system containing polyvinyl or urethane methacrylate-based resin and accelerator, or injected polymer or hybrid mortar adhesive. Provide anchor bolts and hardware with zinc-coated steel for interior applications and stainless steel for exterior applications. Select anchor bolts with strength required for anchor and as tested according to ASTM E 488.

PART 95 - EXECUTION

95.1 APPLICATIONS

- A. Multiple Raceways or Cables: Secure raceways and cables to trapeze member with clamps approved for application by an agency acceptable to authorities having jurisdiction.
- B. Hanger Rod Stiffeners: Install hanger rod stiffeners where indicated or scheduled on Drawings to receive them and where required to prevent buckling of hanger rods due to seismic forces.
- C. Strength of Support and Seismic-Restraint Assemblies: Where not indicated, select sizes of components so strength will be adequate to carry present and future static and seismic loads within specified loading limits.

95.2 SEISMIC-RESTRAINT DEVICE INSTALLATION

A. Equipment and Hanger Restraints:

1. Install restrained isolators on electrical equipment.
2. Install resilient, bolt-isolation washers on equipment anchor bolts where clearance between anchor and adjacent surface exceeds **0.125 inch (3.2 mm)**.
3. Install seismic-restraint devices using methods approved by an agency acceptable to authorities having jurisdiction providing required submittals for component.

B. Install bushing assemblies for mounting bolts for wall-mounted equipment, arranged to provide resilient media where equipment or equipment-mounting channels are attached to wall.

C. Attachment to Structure: If specific attachment is not indicated, anchor bracing to structure at flanges of beams, at upper truss chords of bar joists, or at concrete members.

D. Drilled-in Anchors:

1. Identify position of reinforcing steel and other embedded items prior to drilling holes for anchors. Do not damage existing reinforcing or embedded items during coring or drilling. Notify the structural engineer if reinforcing steel or other embedded items are encountered during drilling. Locate and avoid prestressed tendons, electrical and telecommunications conduit, and gas lines.
2. Do not drill holes in concrete or masonry until concrete, mortar, or grout has achieved full design strength.
3. Wedge Anchors: Protect threads from damage during anchor installation. Heavy-duty sleeve anchors shall be installed with sleeve fully engaged in the structural element to which anchor is to be fastened.
4. Adhesive Anchors: Clean holes to remove loose material and drilling dust prior to installation of adhesive. Place adhesive in holes proceeding from the bottom of the hole and progressing toward the surface in such a manner as to avoid introduction of air pockets in the adhesive.
5. Set anchors to manufacturer's recommended torque, using a torque wrench.
6. Install zinc-coated steel anchors for interior and stainless-steel anchors for exterior applications.

95.3 ACCOMMODATION OF DIFFERENTIAL SEISMIC MOTION

- ### A. Install flexible connections in runs of raceways, cables, wireways, cable trays, and busways where they cross seismic joints, where adjacent sections or branches are supported by different structural elements, and where they terminate with connection to equipment that is anchored to a different structural element from the one supporting them as they approach equipment.

95.4 FIELD QUALITY CONTROL

A. Tests and Inspections:

1. Obtain Architect's approval before transmitting test loads to structure. Provide temporary load-spreading members.
2. Test at least four of each type and size of installed anchors and fasteners selected by Architect.
3. Test to 90 percent of rated proof load of device.
4. Measure isolator restraint clearance.
5. Measure isolator deflection.

6. Verify snubber minimum clearances.
7. If a device fails test, modify all installations of same type and retest until satisfactory results are achieved.

- B. Remove and replace malfunctioning units and retest as specified above.
- C. Prepare test and inspection reports.

95.5 ADJUSTING

- A. Adjust isolators after isolated equipment is at operating weight.
- B. Adjust limit stops on restrained spring isolators to mount equipment at normal operating height. After equipment installation is complete, adjust limit stops so they are out of contact during normal operation.
- C. Adjust active height of spring isolators.
- D. Adjust restraints to permit free movement of equipment within normal mode of operation.

END OF SECTION

SECTION 260553 - IDENTIFICATION FOR ELECTRICAL SYSTEMS

PART 96 - GENERAL

96.1 SUMMARY

A. Section Includes:

1. Identification for raceways.
2. Identification of power and control cables.
3. Identification for conductors.
4. Underground-line warning tape.
5. Warning labels and signs.
6. Instruction signs.
7. Equipment identification labels.
8. Miscellaneous identification products.

96.2 SUBMITTALS

- A. Product Data: For each electrical identification product indicated.

96.3 QUALITY ASSURANCE

- A. Comply with ANSI A13.1.
- B. Comply with NFPA 70.
- C. Comply with 29 CFR 1910.144 and 29 CFR 1910.145.
- D. Comply with ANSI Z535.4 for safety signs and labels.
- E. Adhesive-attached labeling materials, including label stocks, laminating adhesives, and inks used by label printers, shall comply with UL 969.

96.4 POWER RACEWAY IDENTIFICATION MATERIALS

- A. Comply with ANSI A13.1 for minimum size of letters for legend and for minimum length of color field for each raceway size.
- B. Colors for Raceways Carrying Circuits at 600 V or Less:
1. Black letters on an orange field.
 2. Legend: Indicate voltage.
- C. Self-Adhesive Vinyl Labels for Raceways Carrying Circuits at 600 V or Less: Preprinted, flexible label laminated with a clear, weather- and chemical-resistant coating and matching wraparound adhesive tape for securing ends of legend label.

96.5 ARMORED AND METAL-CLAD CABLE IDENTIFICATION MATERIALS

- A. Comply with ANSI A13.1 for minimum size of letters for legend and for minimum length of color field for each raceway and cable size.
- B. Colors for Raceways Carrying Circuits at 600 V and Less:
 - 1. Black letters on an orange field.
 - 2. Legend: Indicate voltage.
- C. Self-Adhesive Vinyl Labels: Preprinted, flexible label laminated with a clear, weather- and chemical-resistant coating and matching wraparound adhesive tape for securing ends of legend label.

96.6 POWER AND CONTROL CABLE IDENTIFICATION MATERIALS

- A. Comply with ANSI A13.1 for minimum size of letters for legend and for minimum length of color field for each raceway and cable size.
- B. Self-Adhesive Vinyl Labels: Preprinted, flexible label laminated with a clear, weather- and chemical-resistant coating and matching wraparound adhesive tape for securing ends of legend label.
- C. Write-On Tags: Polyester tag, **0.010 inch (0.25 mm)** thick, with corrosion-resistant grommet and cable tie for attachment to conductor or cable.
 - 1. Marker for Tags: Permanent, waterproof, black ink marker recommended by tag manufacturer.

96.7 CONDUCTOR IDENTIFICATION MATERIALS

- A. Color-Coding Conductor Tape: Colored, self-adhesive vinyl tape not less than **3 mils (0.08 mm)** thick by **1 to 2 inches (25 to 50 mm)** wide.
- B. Self-Adhesive Vinyl Labels: Preprinted, flexible label laminated with a clear, weather- and chemical-resistant coating and matching wraparound adhesive tape for securing ends of legend label.

96.8 FLOOR MARKING TAPE

- A. **2-inch- (50-mm-)** wide, **5-mil (0.125-mm)** pressure-sensitive vinyl tape, with black and white stripes and clear vinyl overlay.

96.9 UNDERGROUND-LINE WARNING TAPE

- A. Tape:
 - 1. Recommended by manufacturer for the method of installation and suitable to identify and locate underground electrical and communications utility lines.
 - 2. Printing on tape shall be permanent and shall not be damaged by burial operations.

3. Tape material and ink shall be chemically inert, and not subject to degrading when exposed to acids, alkalis, and other destructive substances commonly found in soils.

B. Color and Printing:

1. Comply with ANSI Z535.1 through ANSI Z535.5.
2. Inscriptions for Red-Colored Tapes: ELECTRIC LINE, HIGH VOLTAGE.
3. Inscriptions for Orange-Colored Tapes: TELEPHONE CABLE, CATV CABLE, COMMUNICATIONS CABLE, OPTICAL FIBER CABLE.

C. Tag:

1. Detectable three-layer laminate, consisting of a printed pigmented polyolefin film, a solid aluminum-foil core, and a clear protective film that allows inspection of the continuity of the conductive core, bright-colored, continuous-printed on one side with the inscription of the utility, compounded for direct-burial service.
2. Overall Thickness: 5 mils (0.125 mm).
3. Foil Core Thickness: 0.35 mil (0.00889 mm).
4. Weight: 28 lb/1000 sq. ft. (13.7 kg/100 sq. m).
5. 3-Inch (75-mm) Tensile According to ASTM D 882: 70 lbf (311.3 N), and 4600 psi (31.7 MPa).

96.10 WARNING LABELS AND SIGNS

A. Comply with NFPA 70 and 29 CFR 1910.145.

B. Self-Adhesive Warning Labels: Factory-printed, multicolor, pressure-sensitive adhesive labels, configured for display on front cover, door, or other access to equipment unless otherwise indicated.

C. Baked-Enamel Warning Signs:

1. Preprinted aluminum signs, punched or drilled for fasteners, with colors, legend, and size required for application.
2. 1/4-inch (6.4-mm) grommets in corners for mounting.
3. Nominal size, 7 by 10 inches (180 by 250 mm).

D. Metal-Backed, Butyrate Warning Signs:

1. Weather-resistant, nonfading, preprinted, cellulose-acetate butyrate signs with 0.0396-inch (1-mm) galvanized-steel backing; and with colors, legend, and size required for application.
2. 1/4-inch (6.4-mm) grommets in corners for mounting.
3. Nominal size, 10 by 14 inches (250 by 360 mm).

E. Warning label and sign shall include, but are not limited to, the following legends:

1. Multiple Power Source Warning: "DANGER - ELECTRICAL SHOCK HAZARD - EQUIPMENT HAS MULTIPLE POWER SOURCES."
2. Workspace Clearance Warning: "WARNING - OSHA REGULATION - AREA IN FRONT OF ELECTRICAL EQUIPMENT MUST BE KEPT CLEAR FOR 36 INCHES (915 MM)."

96.11 INSTRUCTION SIGNS

- A. Engraved, laminated acrylic or melamine plastic, minimum **1/16 inch (1.6 mm)** thick for signs up to **20 sq. inches (129 sq. cm)** and **1/8 inch (3.2 mm)** thick for larger sizes.
 - 1. Engraved legend with black letters on white face.
 - 2. Punched or drilled for mechanical fasteners.
 - 3. Framed with mitered acrylic molding and arranged for attachment at applicable equipment.
- B. Adhesive Film Label: Machine printed, in black, by thermal transfer or equivalent process. Minimum letter height shall be **3/8 inch (10 mm)**.

96.12 EQUIPMENT IDENTIFICATION LABELS

- A. Self-Adhesive, Engraved, Laminated Acrylic or Melamine Label: Adhesive backed, with white letters on a dark-gray background. Minimum letter height shall be **3/8 inch (10 mm)**.

96.13 MISCELLANEOUS IDENTIFICATION PRODUCTS

- A. Paint: Comply with requirements in Division 09 painting Sections for paint materials and application requirements. Select paint system applicable for surface material and location (exterior or interior).
- B. Fasteners for Labels and Signs: Self-tapping, stainless-steel screws or stainless-steel machine screws with nuts and flat and lock washers.

PART 97 - EXECUTION

97.1 INSTALLATION

- A. Location: Install identification materials and devices at locations for most convenient viewing without interference with operation and maintenance of equipment.
- B. Apply identification devices to surfaces that require finish after completing finish work.
- C. Self-Adhesive Identification Products: Clean surfaces before application, using materials and methods recommended by manufacturer of identification device.
- D. Attach signs and plastic labels that are not self-adhesive type with mechanical fasteners appropriate to the location and substrate.
- E. System Identification Color-Coding Bands for Raceways and Cables: Each color-coding band shall completely encircle cable or conduit. Place adjacent bands of two-color markings in contact, side by side. Locate bands at changes in direction, at penetrations of walls and floors, at **50-foot (15-m)** maximum intervals in straight runs, and at **25-foot (7.6-m)** maximum intervals in congested areas.
- F. Underground-Line Warning Tape: During backfilling of trenches install continuous underground-line warning tape directly above line at **6 to 8 inches (150 to 200 mm)** below

finished grade. Use multiple tapes where width of multiple lines installed in a common trench or concrete envelope exceeds **16 inches (400 mm)** overall.

- G. Painted Identification: Comply with requirements in Division 09 painting Sections for surface preparation and paint application.

97.2 IDENTIFICATION SCHEDULE

- A. Accessible Raceways and Metal-Clad Cables, 600 V or Less, for Service, Feeder, and Branch Circuits More Than 30A, and 120V to ground: Install labels at **10-foot (3-m)** maximum intervals.
- B. Accessible Raceways and Cables within Buildings: Identify the covers of each junction and pull box of the following systems with self-adhesive vinyl labels with the wiring system legend and system voltage. System legends shall be as follows:
 - 1. Emergency Power.
 - 2. Power.
 - 3. UPS.
- C. Power-Circuit Conductor Identification, 600 V or Less: For conductors in vaults, pull and junction boxes, manholes, and handholes, use color-coding conductor tape to identify the phase.
 - 1. Color-Coding for Phase and Voltage Level Identification, 600 V or Less: Use colors listed below for ungrounded service, feeder and branch-circuit conductors.
 - a. Color shall be factory applied or field applied for sizes larger than No. 8 AWG, if authorities having jurisdiction permit.
 - b. Colors for 208/120-V Circuits:
 - 1) Phase A: Black.
 - 2) Phase B: Red.
 - 3) Phase C: Blue.
 - c. Colors for 480/277-V Circuits:
 - 1) Phase A: Brown.
 - 2) Phase B: Orange.
 - 3) Phase C: Yellow.
 - d. Field-Applied, Color-Coding Conductor Tape: Apply in half-lapped turns for a minimum distance of **6 inches (150 mm)** from terminal points and in boxes where splices or taps are made. Apply last two turns of tape with no tension to prevent possible unwinding. Locate bands to avoid obscuring factory cable markings.
- D. Install instructional sign including the color-code for grounded and ungrounded conductors using adhesive-film-type labels.
- E. Conductors to Be Extended in the Future: Attach write-on tags to conductors and list source.

- F. Auxiliary Electrical Systems Conductor Identification: Identify field-installed alarm, control, and signal connections.
 - 1. Identify conductors, cables, and terminals in enclosures and at junctions, terminals, and pull points. Identify by system and circuit designation.
 - 2. Use system of marker tape designations that is uniform and consistent with system used by manufacturer for factory-installed connections.
 - 3. Coordinate identification with Project Drawings, manufacturer's wiring diagrams, and the Operation and Maintenance Manual.

- G. Locations of Underground Lines: Identify with underground-line warning tape for power, lighting, communication, and control wiring and optical fiber cable.
 - 1. Limit use of underground-line warning tape to direct-buried cables.
 - 2. Install underground-line warning tape for both direct-buried cables and cables in raceway.

- H. Workspace Indication: Install floor marking tape to show working clearances in the direction of access to live parts. Workspace shall be as required by NFPA 70 and 29 CFR 1926.403 unless otherwise indicated. Do not install at flush-mounted panelboards and similar equipment in finished spaces.

- I. Warning Labels for Indoor Cabinets, Boxes, and Enclosures for Power and Lighting: Self-adhesive warning labels.
 - 1. Comply with 29 CFR 1910.145.
 - 2. Identify system voltage with black letters on an orange background.
 - 3. Apply to exterior of door, cover, or other access.
 - 4. For equipment with multiple power or control sources, apply to door or cover of equipment including, but not limited to, the following:
 - a. Power transfer switches.
 - b. Controls with external control power connections.

- J. Operating Instruction Signs: Install instruction signs to facilitate proper operation and maintenance of electrical systems and items to which they connect. Install instruction signs with approved legend where instructions are needed for system or equipment operation.

- K. Emergency Operating Instruction Signs: Install instruction signs with white legend on a red background with minimum **3/8-inch- (10-mm-)** high letters for emergency instructions at equipment used for power transfer.

- L. Equipment Identification Labels: On each unit of equipment, install unique designation label that is consistent with wiring diagrams, schedules, and the Operation and Maintenance Manual. Apply labels to disconnect switches and protection equipment, central or master units, control panels, control stations, terminal cabinets, and racks of each system. Systems include power, lighting, control, communication, signal, monitoring, and alarm systems unless equipment is provided with its own identification.
 - 1. Labeling Instructions:
 - a. Indoor Equipment: Self-adhesive, engraved, laminated acrylic or melamine label. Unless otherwise indicated, provide a single line of text with **1/2-inch-**

(13-mm-) high letters on 1-1/2-inch- (38-mm-) high label; where two lines of text are required, use labels 2 inches (50 mm) high.

- b. Outdoor Equipment: Engraved, laminated acrylic or melamine label, Stenciled legend 4 inches (100 mm) high.
- c. Elevated Components: Increase sizes of labels and letters to those appropriate for viewing from the floor.
- d. Unless provided with self-adhesive means of attachment, fasten labels with appropriate mechanical fasteners that do not change the NEMA or NRTL rating of the enclosure.

END OF SECTION

SECTION 262200 - LOW-VOLTAGE TRANSFORMERS

PART 98 - GENERAL

98.1 SUMMARY

- A. This Section includes the following types of dry-type transformers rated 600 V and less, with capacities up to 1000 kVA:
 - 1. Distribution transformers.

98.2 SUBMITTALS

- A. Product Data: For each product indicated.
- B. Shop Drawings: Indicate dimensions and weights.
 - 1. Wiring Diagrams: Power, signal, and control wiring.
- C. Manufacturer Seismic Qualification Certification: Submit certification that transformers, accessories, and components will withstand seismic forces defined in Division 26 Section "Vibration and Seismic Controls for Electrical Systems."
- D. Field quality-control test reports.
- E. Operation and maintenance data.

98.3 QUALITY ASSURANCE

- A. Electrical Components, Devices, and Accessories: Listed and labeled as defined in NFPA 70, Article 100, by a testing agency acceptable to authorities having jurisdiction, and marked for intended use.
- B. Comply with IEEE C57.12.91, "Test Code for Dry-Type Distribution and Power Transformers."

PART 99 - PRODUCTS

99.1 MANUFACTURERS

- A. Available Manufacturers: Subject to compliance with requirements, manufacturers offering products that may be incorporated into the Work include, but are not limited to, the following:
 - 1. ACME Electric Corporation; Power Distribution Products Division.
 - 2. Challenger Electrical Equipment Corp.; a division of Eaton Corp.
 - 3. Controlled Power Company.
 - 4. Eaton Electrical Inc.; Cutler-Hammer Products.

5. Federal Pacific Transformer Company; Division of Electro-Mechanical Corp.
6. General Electric Company.
7. Hammond Co.; Matra Electric, Inc.
8. Magnetek Power Electronics Group.
9. Micron Industries Corp.
10. Myers Power Products, Inc.
11. Siemens Energy & Automation, Inc.
12. Sola/Hevi-Duty.
13. Square D; Schneider Electric.

99.2 GENERAL TRANSFORMER REQUIREMENTS

- A. Description: Factory-assembled and -tested, air-cooled units for 60-Hz service.
- B. Cores: Grain-oriented, non-aging silicon steel.
- C. Coils: Continuous windings without splices except for taps.
 1. Internal Coil Connections: Brazed or pressure type.
 2. Coil Material: Aluminum.

99.3 DISTRIBUTION TRANSFORMERS

- A. Comply with NEMA ST 20, and list and label as complying with UL 1561.
- B. Provide transformers that are constructed to withstand seismic forces specified in Division 26 Section "Vibration and Seismic Controls for Electrical Systems."
- C. Cores: One leg per phase.
- D. Enclosure: Ventilated, NEMA 250, Type 2.
 1. Core and coil shall be encapsulated within resin compound, sealing out moisture and air.
 2. Core and coil shall be encapsulated within resin compound, sealing out moisture and air.
- E. Transformer Enclosure Finish: Comply with NEMA 250.
 1. Finish Color: Gray.
- F. Taps for Transformers Smaller Than 3 kVA: One 5 percent tap above normal full capacity.
- G. Taps for Transformers 7.5 to 24 kVA: Two 5 percent taps below rated voltage.
- H. Taps for Transformers 25 kVA and Larger: Two 2.5 percent taps above and four 2.5 percent taps below normal full capacity.
- I. Insulation Class: 220 deg C, UL-component-recognized insulation system with a maximum of 150 deg C rise above 40 deg C ambient temperature.
- J. Energy Efficiency for Transformers Rated 15 kVA and Larger:

1. Complying with NEMA TP 1, Class 1 efficiency levels.
2. Tested according to NEMA TP 2.

K. Wall Brackets: Manufacturer's standard brackets.

99.4 IDENTIFICATION DEVICES

A. Nameplates: Engraved, laminated-plastic or metal nameplate. Nameplates are specified in Division 26 Section "Identification for Electrical Systems."

PART 100 - EXECUTION

100.1 INSTALLATION

A. Install wall-mounting transformers level and plumb with wall brackets fabricated by transformer manufacturer.

1. Brace wall-mounting transformers as specified in Division 26 Section "Vibration and Seismic Controls for Electrical Systems."

B. Construct concrete bases and anchor floor-mounting transformers according to manufacturer's written instructions, seismic codes applicable to Project, and requirements in Division 26 Section "Hangers and Supports for Electrical Systems."

100.2 FIELD QUALITY CONTROL

A. Perform tests and inspections.

B. Tests and Inspections:

1. Perform each visual and mechanical inspection and electrical test stated in NETA Acceptance Testing Specification. Certify compliance with test parameters.
2. Infrared Scanning: Two months after Substantial Completion, perform an infrared scan of transformer connections.
 - a. Use an infrared-scanning device designed to measure temperature or detect significant deviations from normal values. Provide documentation of device calibration.
 - b. Perform 2 follow-up infrared scans of transformers, one at 4 months and the other at 11 months after Substantial Completion.
 - c. Prepare a certified report identifying transformer checked and describing results of scanning. Include notation of deficiencies detected, remedial action taken, and scanning observations after remedial action.

100.3 ADJUSTING

A. Adjust transformer taps to provide optimum voltage conditions at secondary terminals. Optimum is defined as not exceeding nameplate voltage plus 10 percent and not being

lower than nameplate voltage minus 3 percent at maximum load conditions. Submit recording and tap settings as test results.

- B. Connect buck-boost transformers to provide nameplate voltage of equipment being served, plus or minus 5 percent, at secondary terminals.
- C. Output Settings Report: Prepare a written report recording output voltages and tap settings.

END OF SECTION

SECTION 262413 - SWITCHBOARDS

PART 101 - GENERAL

101.1 SUMMARY

A. Section Includes:

1. Service and distribution switchboards rated 600 V and less.
2. Disconnecting and overcurrent protective devices.
3. Accessory components and features.
4. Identification.

101.2 PERFORMANCE REQUIREMENTS

A. Seismic Performance: Switchboards shall withstand the effects of earthquake motions determined according to SEI/ASCE 7.

1. The term "withstand" means "the unit will remain in place without separation of any parts from the device when subjected to the seismic forces specified and the unit will be fully operational after the seismic event."

101.3 SUBMITTALS

A. Product Data: For each type of product indicated.

B. Shop Drawings: For each switchboard and related equipment.

1. Include dimensioned plans, elevations, sections, and details, including required clearances and service space around equipment. Show tabulations of installed devices, equipment features, and ratings.
2. Include time-current coordination curves for each type and rating of overcurrent protective device included in switchboards.
3. Include schematic and wiring diagrams for power, signal, and control wiring.

C. Seismic Qualification Certificates: Submit certification that switchboards, overcurrent protective devices, accessories, and components will withstand seismic forces defined in Division 26 Section "Vibration and Seismic Controls for Electrical Systems."

D. Field quality-control reports.

E. Operation and maintenance data.

101.4 QUALITY ASSURANCE

A. Electrical Components, Devices, and Accessories: Listed and labeled as defined in NFPA 70, by a qualified testing agency, and marked for intended location and application.

- B. Comply with NEMA PB 2.
- C. Comply with NFPA 70.
- D. Comply with UL 891.

101.5 WARRANTY

- A. Special Warranty: Manufacturer's standard form in which manufacturer agrees to repair or replace transient voltage suppression devices that fail in materials or workmanship within specified warranty period.
 - 1. Warranty Period: Five years from date of Substantial Completion.

PART 102 - PRODUCTS

102.1 MANUFACTURED UNITS

- A. Manufacturers: Subject to compliance with requirements, available manufacturers offering products that may be incorporated into the Work include or approved equal to the following:
 - 1. Eaton Electrical Inc.; Cutler-Hammer Business Unit.
 - 2. General Electric Company; GE Consumer & Industrial - Electrical Distribution.
 - 3. Siemens Energy & Automation, Inc.
 - 4. Square D; a brand of Schneider Electric.
- B. Front-Connected, Front-Accessible Switchboards:
 - 1. Main Devices: Fixed, individually mounted.
 - 2. Branch Devices: Panel mounted.
 - 3. Sections front and rear aligned.
- C. Main-Bus Continuous: as indicated on single line diagram.
- D. Seismic Requirements: Fabricate and test switchboards according to IEEE 344 to withstand seismic forces defined in Division 26 Section "Vibration and Seismic Controls for Electrical Systems."
- E. Enclosure: Stainless Steel, NEMA 3R.
 - 1. Enclosure Finish: Factory-applied finish in manufacturer's standard gray finish over a rust-inhibiting primer on treated metal surface.
 - 2. Enclosure: Flat roof; bolt-on rear covers for each section, with provisions for padlocking.
- F. Utility Metering Compartment: Fabricated, barrier compartment and section complying with utility company's requirements. If separate vertical section is required for utility metering, match and align with basic switchboard. Provide service entrance label and necessary applicable service entrance features.

- G. Bus Transition and Incoming Pull Sections: Matched and aligned with basic switchboard.
- H. Hinged Front Panels: Allow access to circuit breaker, metering, accessory, and blank compartments.
- I. Phase and Neutral Buses and Connections: Three phase, four wire unless otherwise indicated. Tin-plated, high-strength, electrical-grade aluminum alloy with tin-plated aluminum circuit-breaker line connections.
 - 1. Ground Bus: **1/4-by-2-inch- (6-by-50-mm-)** minimum size, hard-drawn copper of 98 percent conductivity, equipped with pressure connectors for feeder and branch-circuit ground conductors.
 - 2. Main Phase Buses and Equipment Ground Buses: Uniform capacity for entire length of switchboard's main and distribution sections. Provide for future extensions from both ends.
 - 3. Neutral Buses: 50 percent of the ampacity of phase buses unless otherwise indicated, equipped with pressure connectors for outgoing circuit neutral cables.
- J. Future Devices: Equip compartments with mounting brackets, supports, bus connections, and appurtenances at full rating of circuit-breaker compartment.

102.2 DISCONNECTING AND OVERCURRENT PROTECTIVE DEVICES

- A. Molded-Case Circuit Breaker (MCCB): Comply with UL 489, with interrupting capacity to meet available fault currents.
 - 1. Thermal-Magnetic Circuit Breakers: Inverse time-current element for low-level overloads, and instantaneous magnetic trip element for short circuits. Adjustable magnetic trip setting for circuit-breaker frame sizes 250 A and larger.
 - 2. Adjustable Instantaneous-Trip Circuit Breakers: Magnetic trip element with front-mounted, field-adjustable trip setting.
 - 3. Electronic trip circuit breakers with rms sensing; field-replaceable rating plug or field-replicable electronic trip; and the following field-adjustable settings:
 - a. Instantaneous trip.
 - b. Long- and short-time pickup levels.
 - c. Long- and short-time time adjustments.
 - d. Ground-fault pickup level, time delay, and I^2t response.
 - 4. Molded-Case Circuit-Breaker (MCCB) Features and Accessories:
 - a. Standard frame sizes, trip ratings, and number of poles.
 - b. Lugs: Mechanical style, suitable for number, size, trip ratings, and conductor material.
 - c. Application Listing: Appropriate for application; Type SWD for switching fluorescent lighting loads; Type HID for feeding fluorescent and high-intensity discharge (HID) lighting circuits.
 - d. Ground-Fault Protection: Integrally mounted relay and trip unit with adjustable pickup and time-delay settings, push-to-test feature, and ground-fault indicator.

- e. Shunt Trip: 120-V trip coil energized from separate circuit, set to trip at 55 percent of rated voltage.

102.3 ACCESSORY COMPONENTS AND FEATURES

- A. Portable Test Set: For testing functions of solid-state trip devices without removing from switchboard. Include relay and meter test plugs suitable for testing switchboard meters and switchboard class relays.

102.4 IDENTIFICATION

- A. Service Equipment Label: NRTL labeled for use as service equipment for switchboards with one or more service disconnecting and overcurrent protective devices.

PART 103 - EXECUTION

103.1 INSTALLATION

- A. Receive, inspect, handle, store and install switchboards and accessories according to NECA 400 and NEMA PB 2.1.
- B. Equipment Mounting: Install switchboards on concrete base, 4-inch (100-mm) nominal thickness. Comply with requirements for concrete base specified in Division 03 Section "Miscellaneous Cast-in-Place Concrete."
 - 1. Install dowel rods to connect concrete base to concrete floor. Unless otherwise indicated, install dowel rods on 18-inch (450-mm) centers around the full perimeter of concrete base.
 - 2. For supported equipment, install epoxy-coated anchor bolts that extend through concrete base and anchor into structural concrete floor.
 - 3. Place and secure anchorage devices. Use setting drawings, templates, diagrams, instructions, and directions furnished with items to be embedded.
 - 4. Install anchor bolts to elevations required for proper attachment to switchboards.
- C. Temporary Lifting Provisions: Remove temporary lifting eyes, channels, and brackets and temporary blocking of moving parts from switchboard units and components.
- D. Comply with mounting and anchoring requirements specified in Division 26 Section "Vibration and Seismic Controls for Electrical Systems."
- E. Install filler plates in unused spaces of panel-mounted sections.
- F. Install overcurrent protective devices.
 - 1. Set field-adjustable switches and circuit-breaker trip ranges.
- G. Comply with NECA 1.

103.2 IDENTIFICATION

- A. Identify field-installed conductors, interconnecting wiring, and components; provide warning signs complying with requirements for identification specified in Division 26 Section "Identification for Electrical Systems."
- B. Switchboard Nameplates: Label each switchboard compartment with a nameplate complying with requirements for identification specified in Division 26 Section "Identification for Electrical Systems."
- C. Device Nameplates: Label each disconnecting and overcurrent protective device and each meter and control device mounted in compartment doors with a nameplate complying with requirements for identification specified in Division 26 Section "Identification for Electrical Systems."

103.3 FIELD QUALITY CONTROL

- A. Acceptance Testing Preparation:
 - 1. Test insulation resistance for each switchboard bus, component, connecting supply, feeder, and control circuit.
 - 2. Test continuity of each circuit.
- B. A qualified inspector shall perform tests and Inspections. Inspections are to be performed by an independent third party and are intended to ensure that the work of the prime contractor is in accordance with the Contract Documents and applicable building codes.
 - 1. Perform each visual and mechanical inspection and electrical test stated in NETA Acceptance Testing Specification. Certify compliance with test parameters.
 - 2. Correct malfunctioning units on-site, where possible, and retest to demonstrate compliance; otherwise, replace with new units and retest.
 - 3. Test and adjust controls, remote monitoring, and safeties. Replace damaged and malfunctioning controls and equipment.
- C. Switchboard will be considered defective if it does not pass tests and inspections.
- D. Prepare test and inspection reports, including a certified report that identifies switchboards included and that describes scanning results. Include notation of deficiencies detected, remedial action taken, and observations after remedial action.

END OF SECTION

SECTION 262416 - PANELBOARDS

PART 104 - GENERAL

104.1 SUMMARY

- A. Section includes distribution panelboards and lighting and appliance branch-circuit panelboards.

104.2 PERFORMANCE REQUIREMENTS

- A. Seismic Performance: Panelboards shall withstand the effects of earthquake motions determined according to SEI/ASCE 7.
 - 1. The term "withstand" means "the unit will remain in place without separation of any parts from the device when subjected to the seismic forces specified and the unit will be fully operational after the seismic event."

104.3 SUBMITTALS

- A. Product Data: For each type of product indicated.
- B. Shop Drawings: For each panelboard and related equipment.
 - 1. Include dimensioned plans, elevations, sections, and details. Show tabulations of installed devices, equipment features, and ratings.
 - 2. Detail enclosure types and details for types other than NEMA 250, Type 1.
 - 3. Detail bus configuration, current, and voltage ratings.
 - 4. Short-circuit current rating of panelboards and overcurrent protective devices.
 - 5. Include evidence of NRTL listing for series rating of installed devices.
 - 6. Detail features, characteristics, ratings, and factory settings of individual overcurrent protective devices and auxiliary components.
 - 7. Include wiring diagrams for power, signal, and control wiring.
 - 8. Include time-current coordination curves for each type and rating of overcurrent protective device included in panelboards.
- C. Seismic Qualification Certificates: Submit certification that panelboards, overcurrent protective devices, accessories, and components will withstand seismic forces defined in Division 26 Section "Vibration and Seismic Controls for Electrical Systems."
- D. Field quality-control reports.
- E. Panelboard schedules for installation in panelboards.
- F. Operation and maintenance data.

104.4 QUALITY ASSURANCE

- A. Electrical Components, Devices, and Accessories: Listed and labeled as defined in NFPA 70, by a qualified testing agency, and marked for intended location and application.
- B. Comply with NEMA PB 1.
- C. Comply with NFPA 70.

104.5 WARRANTY

- A. Special Warranty: Manufacturer's standard form in which manufacturer agrees to repair or replace transient voltage suppression devices that fail in materials or workmanship within specified warranty period.
 - 1. Warranty Period: Five years from date of Substantial Completion.

PART 105 - PRODUCTS

105.1 GENERAL REQUIREMENTS FOR PANELBOARDS

- A. Fabricate and test panelboards according to IEEE 344 to withstand seismic forces defined in Division 26 Section "Vibration and Seismic Controls for Electrical Systems."
- B. Enclosures: Flush- and surface-mounted cabinets.
 - 1. Rated for environmental conditions at installed location.
 - a. Indoor Dry and Clean Locations: NEMA 250, Type 1.
 - b. Outdoor Locations: NEMA 250, Type 4X stainless steels.
 - c. Kitchen and Wash-Down Areas: NEMA 250, Type 4X stainless steel.
 - d. Other Wet or Damp Indoor Locations: NEMA 250, Type 4X stainless steel.
 - 2. Front: Secured to box with concealed trim clamps. For surface-mounted fronts, match box dimensions; for flush-mounted fronts, overlap box.
 - 3. Hinged Front Cover: Entire front trim hinged to box and with standard door within hinged trim cover.
 - 4. Directory Card: Inside panelboard door, mounted in transparent card holder.
- C. Incoming Mains Location: Top and bottom.
- D. Phase, Neutral, and Ground Buses: Tin-plated aluminum.
- E. Conductor Connectors: Suitable for use with conductor material and sizes.
 - 1. Material: Tin-plated aluminum.
 - 2. Main and Neutral Lugs: Mechanical type.
 - 3. Ground Lugs and Bus Configured Terminators: Mechanical type.
 - 4. Feed-Through Lugs: Mechanical type, suitable for use with conductor material. Locate at opposite end of bus from incoming lugs or main device.
 - 5. Subfeed (Double) Lugs: Mechanical type suitable for use with conductor material. Locate at same end of bus as incoming lugs or main device.

- F. Service Equipment Label: NRTL labeled for use as service equipment for panelboards with one or more main service disconnecting and overcurrent protective devices.
- G. Future Devices: Mounting brackets, bus connections, filler plates, and necessary appurtenances required for future installation of devices.
- H. Panelboard Short-Circuit Current Rating: Fully rated to interrupt symmetrical short-circuit current available at terminals.

105.2 DISTRIBUTION PANELBOARDS

- A. Manufacturers: Subject to compliance with requirements, available manufacturers offering products that may be incorporated into the Work include, but are not limited to, the following:
 1. Eaton Electrical Inc.; Cutler-Hammer Business Unit.
 2. General Electric Company; GE Consumer & Industrial - Electrical Distribution.
 3. Siemens Energy & Automation, Inc.
 4. Square D; a brand of Schneider Electric.
- B. Panelboards: NEMA PB 1, power and feeder distribution type.
- C. Doors: Secured with vault-type latch with tumbler lock; keyed alike.
- D. Mains: Lugs only.
- E. Branch Overcurrent Protective Devices: For Circuit-Breaker Frame Sizes 125 A and Smaller: Bolt-on circuit breakers.
- F. Branch Overcurrent Protective Devices: For Circuit-Breaker Frame Sizes Larger Than 125 A: Bolt-on circuit breakers.

105.3 LIGHTING AND APPLIANCE BRANCH-CIRCUIT PANELBOARDS

- A. Manufacturers: Subject to compliance with requirements, available manufacturers offering products that may be incorporated into the Work include, but are not limited to, the following:
 1. Eaton Electrical Inc.; Cutler-Hammer Business Unit.
 2. General Electric Company; GE Consumer & Industrial - Electrical Distribution.
 3. Siemens Energy & Automation, Inc.
 4. Square D; a brand of Schneider Electric.
- B. Panelboards: NEMA PB 1, lighting and appliance branch-circuit type.
- C. Mains: Circuit breaker or lugs only, as indicated on panel schedules.
- D. Branch Overcurrent Protective Devices: Bolt-on circuit breakers, replaceable without disturbing adjacent units.
- E. Doors: Concealed hinges; secured with flush latch with tumbler lock; keyed alike.

- F. Column-Type Panelboards: Narrow gutter extension, with cover, to overhead junction box equipped with ground and neutral terminal buses.

105.4 DISCONNECTING AND OVERCURRENT PROTECTIVE DEVICES

- A. Manufacturers: Subject to compliance with requirements, available manufacturers offering products that may be incorporated into the Work include, but are not limited to, the following:
 - 1. Eaton Electrical Inc.; Cutler-Hammer Business Unit.
 - 2. General Electric Company; GE Consumer & Industrial - Electrical Distribution.
 - 3. Siemens Energy & Automation, Inc.
 - 4. Square D; a brand of Schneider Electric.

- B. Molded-Case Circuit Breaker (MCCB): Comply with UL 489, with interrupting capacity to meet available fault currents.
 - 1. Thermal-Magnetic Circuit Breakers: Inverse time-current element for low-level overloads, and instantaneous magnetic trip element for short circuits. Adjustable magnetic trip setting for circuit-breaker frame sizes 250 A and larger.
 - 2. Adjustable Instantaneous-Trip Circuit Breakers: Magnetic trip element with front-mounted, field-adjustable trip setting.
 - 3. Electronic trip circuit breakers with rms sensing; field-replaceable rating plug or field-replicable electronic trip; and the following field-adjustable settings:
 - a. Instantaneous trip.
 - b. Long- and short-time pickup levels.
 - c. Long- and short-time time adjustments.
 - d. Ground-fault pickup level, time delay, and I^2t response.
 - 4. Ground-Fault Equipment Protection (GFEP) Circuit Breakers: Class B ground-fault protection (30-mA trip).
 - 5. Molded-Case Circuit-Breaker (MCCB) Features and Accessories:
 - a. Standard frame sizes, trip ratings, and number of poles.
 - b. Lugs: Mechanical style, suitable for number, size, trip ratings, and conductor materials.
 - c. Application Listing: Appropriate for application; Type SWD for switching fluorescent lighting loads; Type HID for feeding fluorescent and high-intensity discharge (HID) lighting circuits.
 - d. Ground-Fault Protection: Integrally mounted relay and trip unit with adjustable pickup and time-delay settings, push-to-test feature, and ground-fault indicator.
 - e. Shunt Trip: 120-V trip coil energized from separate circuit, set to trip at 55 percent of rated voltage.
 - f. Handle Padlocking Device: Fixed attachment, for locking circuit-breaker handle in on or off position.
 - g. Handle Clamp: Loose attachment, for holding circuit-breaker handle in on position.

105.5 ACCESSORY COMPONENTS AND FEATURES

- A. Portable Test Set: For testing functions of solid-state trip devices without removing from panelboard. Include relay and meter test plugs suitable for testing panelboard meters and switchboard class relays.

PART 106 - EXECUTION

106.1 INSTALLATION

- A. Receive, inspect, handle, store and install panelboards and accessories according to NECA 407 and NEMA PB 1.1.
- B. Comply with mounting and anchoring requirements specified in Division 26 Section "Vibration and Seismic Controls for Electrical Systems."
- C. Mount panelboards such that the highest position of any operating handle for circuit breakers or switches does not exceed 79 inches above the floor or working platform, unless otherwise indicated.
- D. Mount panelboard cabinet plumb and rigid without distortion of box. Mount recessed panelboards with fronts uniformly flush with wall finish and mating with back box.
- E. Install overcurrent protective devices and controllers not already factory installed.
 - 1. Set field-adjustable, circuit-breaker trip ranges.
- F. Install filler plates in unused spaces.
- G. Stub four 1-inch (27-GRC) empty conduits from panelboard into accessible ceiling space or space designated to be ceiling space in the future. Stub four 1-inch (27-GRC) empty conduits into raised floor space or below slab not on grade.
- H. Arrange conductors in gutters into groups and bundle and wrap with wire ties.
- I. Comply with NECA 1.

106.2 IDENTIFICATION

- A. Identify field-installed conductors, interconnecting wiring, and components; provide warning signs complying with Division 26 Section "Identification for Electrical Systems."
- B. Create a directory to indicate installed circuit loads and incorporating Owner's final room designations. Obtain approval before installing. Use a computer or typewriter to create directory; handwritten directories are not acceptable.
- C. Panelboard Nameplates: Label each panelboard with a nameplate complying with requirements for identification specified in Division 26 Section "Identification for Electrical Systems."

- D. Device Nameplates: Label each branch circuit device in distribution panelboards with a nameplate complying with requirements for identification specified in Division 26 Section "Identification for Electrical Systems."

106.3 FIELD QUALITY CONTROL

- A. Perform tests and inspections.
- B. Acceptance Testing Preparation:
 - 1. Test insulation resistance for each panelboard bus, component, connecting supply, feeder, and control circuit.
 - 2. Test continuity of each circuit.
- C. Tests and Inspections:
 - 1. Perform each visual and mechanical inspection and electrical test stated in NETA Acceptance Testing Specification. Certify compliance with test parameters.
 - 2. Correct malfunctioning units on-site, where possible, and retest to demonstrate compliance; otherwise, replace with new units and retest.
- D. Panelboards will be considered defective if they do not pass tests and inspections.
- E. Prepare test and inspection reports, including a certified report that identifies panelboards included and that describes scanning results. Include notation of deficiencies detected, remedial action taken, and observations after remedial action.

END OF SECTION

SECTION 262726 - WIRING DEVICES

PART 107 - GENERAL

107.1 SUMMARY

- A. This Section includes the following:
 - 1. Receptacles, receptacles with integral GFCI, and associated device plates.
 - 2. Snap switches and wall-box dimmers.
 - 3. Solid-state fan speed controls.

107.2 SUBMITTALS

- A. Product Data: For each type of product indicated.
- B. Shop Drawings: List of legends and description of materials and process used for premarking wall plates.
- C. Samples: One for each type of device and wall plate specified, in each color specified.
- D. Operation and Maintenance Data: For wiring devices to include in all manufacturers' packing label warnings and instruction manuals that include labeling conditions.

107.3 QUALITY ASSURANCE

- A. Electrical Components, Devices, and Accessories: Listed and labeled as defined in NFPA 70, Article 100, by a testing agency acceptable to authorities having jurisdiction, and marked for intended use.
- B. Comply with NFPA 70.

PART 108 - PRODUCTS

108.1 MANUFACTURERS

- A. Manufacturers' Names: Shortened versions (shown in parentheses) of the following manufacturers' names are used in other Part 2 articles:
 - 1. Cooper Wiring Devices; a division of Cooper Industries, Inc. (Cooper).
 - 2. Hubbell Incorporated; Wiring Device-Kellems (Hubbell).
 - 3. Leviton Mfg. Company Inc. (Leviton).
 - 4. Pass & Seymour/Legrand; Wiring Devices & Accessories (Pass & Seymour).

108.2 STRAIGHT BLADE RECEPTACLES

- A. Convenience Receptacles, 125 V, 20 A: Comply with NEMA WD 1, NEMA WD 6 configuration 5-20R, and UL 498.
 - 1. Available Products: Subject to compliance with requirements, products that may be incorporated into the Work include, but are not limited to, the following:
 - 2. Products: Subject to compliance with requirements, provide one of the following:
 - a. Cooper; 5351 (single), 5352 (duplex).
 - b. Hubbell; HBL5351 (single), CR5352 (duplex).
 - c. Leviton; 5891 (single), 5352 (duplex).
 - d. Pass & Seymour; 5381 (single), 5352 (duplex).

108.3 GFCI RECEPTACLES

- A. General Description: Straight blade, non-feed-through type. Comply with NEMA WD 1, NEMA WD 6, UL 498, and UL 943, Class A, and include indicator light that is lighted when device is tripped.
- B. Duplex GFCI Convenience Receptacles, 125 V, 20 A:
 - 1. Available Products: Subject to compliance with requirements, products that may be incorporated into the Work include, but are not limited to, the following:
 - 2. Products: Subject to compliance with requirements, provide one of the following:
 - a. Cooper; GF20.
 - b. Pass & Seymour; 2084.

108.4 SNAP SWITCHES

- A. Comply with NEMA WD 1 and UL 20.
- B. Switches, 120/277 V, 20 A:
 - 1. Available Products: Subject to compliance with requirements, products that may be incorporated into the Work include, but are not limited to, the following:
 - 2. Products: Subject to compliance with requirements, provide one of the following:
 - a. Cooper; 2221 (single pole), 2222 (two pole), 2223 (three way), 2224 (four way).
 - b. Hubbell; CS1221 (single pole), CS1222 (two pole), CS1223 (three way), CS1224 (four way).
 - c. Leviton; 1221-2 (single pole), 1222-2 (two pole), 1223-2 (three way), 1224-2 (four way).
 - d. Pass & Seymour; 20AC1 (single pole), 20AC2 (two pole), 20AC3 (three way), 20AC4 (four way).
- C. Single-Pole, Double-Throw, Momentary Contact, Center-Off Switches, 120/277 V, 20 A; for use with mechanically held lighting contactors.
 - 1. Available Products: Subject to compliance with requirements, products that may be incorporated into the Work include, but are not limited to, the following:

2. Products: Subject to compliance with requirements, provide one of the following:
 - a. Cooper; 1995.
 - b. Hubbell; HBL1557.
 - c. Leviton; 1257.
 - d. Pass & Seymour; 1251.

108.5 WALL PLATES

- A. Single and combination types to match corresponding wiring devices.
 1. Plate-Securing Screws: Metal with head color to match plate finish.
 2. Material for Finished Spaces: Smooth, high-impact thermoplastic.
 3. Material for Damp Locations: Stainless steel with spring-loaded lift cover, and listed and labeled for use in "wet locations."
- B. Wet-Location, Weatherproof Cover Plates: NEMA 250, complying with type 3R weather-resistant thermoplastic "while in use" with lockable cover.

108.6 FINISHES

- A. Color: Wiring device catalog numbers in Section Text do not designate device color.
 1. Wiring Devices Connected to Normal Power System: As selected by Architect, unless otherwise indicated or required by NFPA 70 or device listing.
 2. Wiring Devices Connected to Emergency Power System: Red.

PART 109 - EXECUTION

109.1 INSTALLATION

- A. Comply with NECA 1, including the mounting heights listed in that standard, unless otherwise noted.
- B. Coordination with Other Trades:
 1. Take steps to insure that devices and their boxes are protected. Do not place wall finish materials over device boxes and do not cut holes for boxes with routers that are guided by riding against outside of the boxes.
 2. Keep outlet boxes free of plaster, drywall joint compound, mortar, cement, concrete, dust, paint, and other material that may contaminate the raceway system, conductors, and cables.
 3. Install device boxes in brick or block walls so that the cover plate does not cross a joint unless the joint is troweled flush with the face of the wall.
 4. Install wiring devices after all wall preparation, including painting, is complete.
- C. Conductors:
 1. Do not strip insulation from conductors until just before they are spliced or terminated on devices.

2. Strip insulation evenly around the conductor using tools designed for the purpose. Avoid scoring or nicking of solid wire or cutting strands from stranded wire.
3. The length of free conductors at outlets for devices shall meet provisions of NFPA 70, Article 300, without pigtails.
4. Existing Conductors:
 - a. Cut back and pigtail, or replace all damaged conductors.
 - b. Straighten conductors that remain and remove corrosion and foreign matter.
 - c. Pigtailing existing conductors is permitted provided the outlet box is large enough.

D. Device Installation:

1. Replace all devices that have been in temporary use during construction or that show signs that they were installed before building finishing operations were complete.
2. Keep each wiring device in its package or otherwise protected until it is time to connect conductors.
3. Do not remove surface protection, such as plastic film and smudge covers, until the last possible moment.
4. Connect devices to branch circuits using pigtails that are not less than **6 inches (152 mm)** in length.
5. When there is a choice, use side wiring with binding-head screw terminals. Wrap solid conductor tightly clockwise, 2/3 to 3/4 of the way around terminal screw.
6. Use a torque screwdriver when a torque is recommended or required by the manufacturer.
7. When conductors larger than No. 12 AWG are installed on 15- or 20-A circuits, splice No. 12 AWG pigtails for device connections.
8. Tighten unused terminal screws on the device.
9. When mounting into metal boxes, remove the fiber or plastic washers used to hold device mounting screws in yokes, allowing metal-to-metal contact.

E. Receptacle Orientation:

1. Install ground pin of vertically mounted receptacles up, and on horizontally mounted receptacles to the right.

F. Device Plates: Do not use oversized or extra-deep plates. Repair wall finishes and remount outlet boxes when standard device plates do not fit flush or do not cover rough wall opening.

G. Dimmers:

1. Install dimmers within terms of their listing.
2. Verify that dimmers used for fan speed control are listed for that application.
3. Install unshared neutral conductors on line and load side of dimmers according to manufacturers' device listing conditions in the written instructions.

H. Arrangement of Devices: Unless otherwise indicated, mount flush, with long dimension vertical and with grounding terminal of receptacles on top. Group adjacent switches under single, multigang wall plates.

109.2 IDENTIFICATION

- A. Comply with Division 26 Section "Identification for Electrical Systems."
 - 1. Receptacles: Identify panelboard and circuit number from which served. Use hot, stamped or engraved machine printing with black-filled lettering on face of plate, and durable wire markers or tags inside outlet boxes.

109.3 FIELD QUALITY CONTROL

- A. Perform tests and inspections and prepare test reports.
 - 1. Test Instruments: Use instruments that comply with UL 1436.
 - 2. Test Instrument for Convenience Receptacles: Digital wiring analyzer with digital readout or illuminated LED indicators of measurement.
- B. Tests for Convenience Receptacles:
 - 1. Line Voltage: Acceptable range is 105 to 132 V.
 - 2. Percent Voltage Drop under 15-A Load: A value of 6 percent or higher is not acceptable.
 - 3. Ground Impedance: Values of up to 2 ohms are acceptable.
 - 4. GFCI Trip: Test for tripping values specified in UL 1436 and UL 943.
 - 5. Using the test plug, verify that the device and its outlet box are securely mounted.
 - 6. The tests shall be diagnostic, indicating damaged conductors, high resistance at the circuit breaker, poor connections, inadequate fault current path, defective devices, or similar problems. Correct circuit conditions, remove malfunctioning units and replace with new, and retest as specified above.

END OF SECTION

SECTION 262813 - FUSES

PART 110 - GENERAL

110.1 SUMMARY

- A. Section Includes: Cartridge fuses rated 600-V ac and less for use in enclosed switches and enclosed controllers.

110.2 SUBMITTALS

- A. Product Data: For each type of product indicated.
- B. Operation and maintenance data.

110.3 QUALITY ASSURANCE

- A. Electrical Components, Devices, and Accessories: Listed and labeled as defined in NFPA 70, by a qualified testing agency, and marked for intended location and application.
- B. Comply with NEMA FU 1 for cartridge fuses.
- C. Comply with NFPA 70.

PART 111 - PRODUCTS

111.1 MANUFACTURERS

- A. Manufacturers: Subject to compliance with requirements, available manufacturers offering products that may be incorporated into the Work include, but are not limited to, the following:
 - 1. Cooper Bussmann, Inc.
 - 2. Edison Fuse, Inc.
 - 3. Ferraz Shawmut, Inc.
 - 4. Littelfuse, Inc.

111.2 CARTRIDGE FUSES

- A. Characteristics: NEMA FU 1, nonrenewable cartridge fuses with voltage ratings consistent with circuit voltages.

PART 112 - EXECUTION

112.1 FUSE APPLICATIONS

- A. Motor Branch Circuits: Class RK1, time delay.
- B. Other Branch Circuits: Class RK1, time delay.

112.2 INSTALLATION

- A. Install fuses in fusible devices. Arrange fuses so rating information is readable without removing fuse.

112.3 IDENTIFICATION

- A. Install labels complying with requirements for identification specified in Division 26 Section "Identification for Electrical Systems" and indicating fuse replacement information on inside door of each fused switch and adjacent to each fuse block and holder.

END OF SECTION

SECTION 262816 - ENCLOSED SWITCHES AND CIRCUIT BREAKERS

PART 113 - GENERAL

113.1 SUMMARY

- A. Section Includes:
 - 1. Fusible switches.
 - 2. Nonfusible switches.
 - 3. Receptacle switches.
 - 4. Molded-case circuit breakers (MCCBs).
 - 5. Enclosures.

113.2 DEFINITIONS

- A. NC: Normally closed.
- B. NO: Normally open.
- C. SPDT: Single pole, double throw.

113.3 PERFORMANCE REQUIREMENTS

- A. Seismic Performance: Enclosed switches and circuit breakers shall withstand the effects of earthquake motions determined according to ASCE/SEI 7.
 - 1. The term "withstand" means "the unit will remain in place without separation of any parts from the device when subjected to the seismic forces specified and the unit will be fully operational after the seismic event."

113.4 SUBMITTALS

- A. Product Data: For each type of enclosed switch, circuit breaker, accessory, and component indicated.
- B. Shop Drawings: For enclosed switches and circuit breakers. Include plans, elevations, sections, details, and attachments to other work.
 - 1. Wiring Diagrams: For power, signal, and control wiring.
- C. Seismic Qualification Certificates: For enclosed switches and circuit breakers, accessories, and components, from manufacturer.
- D. Field quality-control reports.
- E. Operation and maintenance data.

113.5 QUALITY ASSURANCE

- A. Electrical Components, Devices, and Accessories: Listed and labeled as defined in NFPA 70, by a qualified testing agency, and marked for intended location and application.
- B. Comply with NFPA 70.

PART 114 - PRODUCTS

114.1 FUSIBLE SWITCHES

- A. Manufacturers: Subject to compliance with requirements, available manufacturers offering products that may be incorporated into the Work include, but are not limited to, the following:
 - 1. Eaton Electrical Inc.; Cutler-Hammer Business Unit.
 - 2. General Electric Company; GE Consumer & Industrial - Electrical Distribution.
 - 3. Siemens Energy & Automation, Inc.
 - 4. Square D; a brand of Schneider Electric.
- B. Type HD, Heavy Duty, Single Throw, 240 or 600-V ac, 1200 A and Smaller: UL 98 and NEMA KS 1, horsepower rated, with clips or bolt pads to accommodate specified fuses, lockable handle with capability to accept three padlocks, and interlocked with cover in closed position.
- C. Accessories:
 - 1. Equipment Ground Kit: Internally mounted and labeled for copper and aluminum ground conductors.
 - 2. Class R Fuse Kit: Provides rejection of other fuse types when Class R fuses are specified.
 - 3. Lugs: Suitable for number, size, and conductor material.

114.2 NONFUSIBLE SWITCHES

- A. Manufacturers: Subject to compliance with requirements, available manufacturers offering products that may be incorporated into the Work include, but are not limited to, the following:
 - 1. Eaton Electrical Inc.; Cutler-Hammer Business Unit.
 - 2. General Electric Company; GE Consumer & Industrial - Electrical Distribution.
 - 3. Siemens Energy & Automation, Inc.
 - 4. Square D; a brand of Schneider Electric.
- B. Type HD, Heavy Duty, Single Throw, 240 or 600-V ac, 1200 A and Smaller: UL 98 and NEMA KS 1, horsepower rated, lockable handle with capability to accept three padlocks, and interlocked with cover in closed position.
- C. Accessories:

1. Equipment Ground Kit: Internally mounted and labeled for copper and aluminum ground conductors.
2. Lugs: Suitable for number, size, and conductor material.

114.3 RECEPTACLE SWITCHES

- A. Manufacturers: Subject to compliance with requirements, available manufacturers offering products that may be incorporated into the Work include, but are not limited to, the following:
 1. Eaton Electrical Inc.; Cutler-Hammer Business Unit.
 2. General Electric Company; GE Consumer & Industrial - Electrical Distribution.
 3. Siemens Energy & Automation, Inc.
 4. Square D; a brand of Schneider Electric.
- B. Type HD, Heavy-Duty, Single-Throw Fusible Switch: 240 or 600-V ac, 30, 60, 100 A; UL 98 and NEMA KS 1; horsepower rated, with clips or bolt pads to accommodate specified fuses; lockable handle with capability to accept three padlocks; interlocked with cover in closed position.
- C. Interlocking Linkage: Provided between the receptacle and switch mechanism to prevent inserting or removing plug while switch is in the on position, inserting any plug other than specified, and turning switch on if an incorrect plug is inserted or correct plug has not been fully inserted into the receptacle.
- D. Receptacle: Polarized, three-phase, four-wire receptacle (fourth wire connected to enclosure ground lug).

114.4 MOLDED-CASE CIRCUIT BREAKERS

- A. Manufacturers: Subject to compliance with requirements, provide products by one of the following:
 1. Eaton Electrical Inc.; Cutler-Hammer Business Unit.
 2. General Electric Company; GE Consumer & Industrial - Electrical Distribution.
 3. Siemens Energy & Automation, Inc.
 4. Square D; a brand of Schneider Electric.
- B. General Requirements: Comply with UL 489, NEMA AB 1, and NEMA AB 3, with interrupting capacity to comply with available fault currents.
- C. Thermal-Magnetic Circuit Breakers: Inverse time-current element for low-level overloads and instantaneous magnetic trip element for short circuits. Adjustable magnetic trip setting for circuit-breaker frame sizes 250 A and larger.
- D. Features and Accessories:
 1. Standard frame sizes, trip ratings, and number of poles.
 2. Lugs: Suitable for number, size, trip ratings, and conductor material.
 3. Application Listing: Appropriate for application; Type SWD for switching fluorescent lighting loads; Type HID for feeding fluorescent and high-intensity discharge lighting circuits.

114.5 ENCLOSURES

- A. Enclosed Switches and Circuit Breakers: NEMA AB 1, NEMA KS 1, NEMA 250, and UL 50, to comply with environmental conditions at installed location.
 - 1. Indoor, Dry and Clean Locations: NEMA 250, Type 1.
 - 2. Outdoor Locations: NEMA 250, Type 4X stainless steel.
 - 3. Kitchen and Wash-Down Areas: NEMA 250, Type 4X stainless steel.
 - 4. Other Wet or Damp, Indoor Locations: NEMA 250, Type 4X, stainless steel.
 - 5. Indoor Locations Subject to Dust, Falling Dirt, and Dripping Noncorrosive Liquids: NEMA 250, Type 12.

PART 115 - EXECUTION

115.1 INSTALLATION

- A. Install individual wall-mounted switches and circuit breakers with tops at uniform height unless otherwise indicated.
- B. Comply with mounting and anchoring requirements specified in Division 26 Section "Vibration and Seismic Controls for Electrical Systems."
- C. Temporary Lifting Provisions: Remove temporary lifting eyes, channels, and brackets and temporary blocking of moving parts from enclosures and components.
- D. Install fuses in fusible devices.
- E. Comply with NECA 1.

115.2 IDENTIFICATION

- A. Comply with requirements in Division 26 Section "Identification for Electrical Systems."
 - 1. Identify field-installed conductors, interconnecting wiring, and components; provide warning signs.
 - 2. Label each enclosure with engraved metal or laminated-plastic nameplate.

115.3 FIELD QUALITY CONTROL

- A. Perform tests and inspections.
- B. Acceptance Testing Preparation:
 - 1. Test insulation resistance for each enclosed switch and circuit breaker, component, connecting supply, feeder, and control circuit.
 - 2. Test continuity of each circuit.
- C. Tests and Inspections:

1. Perform each visual and mechanical inspection and electrical test stated in NETA Acceptance Testing Specification. Certify compliance with test parameters.
 2. Correct malfunctioning units on-site, where possible, and retest to demonstrate compliance; otherwise, replace with new units and retest.
- D. Enclosed switches and circuit breakers will be considered defective if they do not pass tests and inspections.
- E. Prepare test and inspection reports, including a certified report that identifies enclosed switches and circuit breakers and that describes scanning results. Include notation of deficiencies detected, remedial action taken, and observations after remedial action.

END OF SECTION

SECTION 265100 - INTERIOR LIGHTING

PART 116 - GENERAL

116.1 SUMMARY

A. Section Includes:

1. Interior lighting fixtures, LED diodes and ballasts.
2. Emergency lighting battery back-up units.
3. Exit signs.
4. Lighting fixture supports.

116.2 SUBMITTALS

- A. Product Data:** For each type of lighting fixture, arranged in order of fixture designation. Include data on features, accessories, and finishes.
- B. Shop Drawings:** Show details of nonstandard or custom lighting fixtures. Indicate dimensions, weights, methods of field assembly, components, features, and accessories. **Product Certificates:** For each type of ballast for bi-level and dimmer-controlled fixtures, from manufacturer.
- C. Field quality-control reports.**

116.3 QUALITY ASSURANCE

- A. Electrical Components, Devices, and Accessories:** Listed and labeled as defined in NFPA 70, by a qualified testing agency, and marked for intended location and application.
- B. Comply with NFPA 70.**

PART 117 - PRODUCTS

117.1 MANUFACTURERS

- A. Products:** Subject to compliance with requirements, provide product indicated on Drawings.

117.2 GENERAL REQUIREMENTS FOR LIGHTING FIXTURES AND COMPONENTS

- A. Recessed Fixtures: Comply with NEMA LE 4 for ceiling compatibility for recessed fixtures.
- B. Metal Parts: Free of burrs and sharp corners and edges.
- C. Sheet Metal Components: Steel unless otherwise indicated. Form and support to prevent warping and sagging.
- D. Doors, Frames, and Other Internal Access: Smooth operating, free of light leakage under operating conditions, and designed to permit relamping without use of tools. Designed to prevent doors, frames, lenses, diffusers, and other components from falling accidentally during relamping and when secured in operating position.
- E. Diffusers and Globes:
 - 1. Acrylic Lighting Diffusers: 100 percent virgin acrylic plastic. High resistance to yellowing and other changes due to aging, exposure to heat, and UV radiation.
 - a. Lens Thickness: At least 0.125 inch unless otherwise indicated.
 - b. UV stabilized.
 - 2. Glass: Annealed crystal glass unless otherwise indicated.

117.3 DRIVERS FOR LED DIODES

- 1. LED drivers shall include the following features unless otherwise indicated:
 - 1. Minimum efficiency: 85% at full load.
 - 2. Minimum Operating Ambient Temperature: -20° C. (-4° F.)
 - 3. Input Voltage: 120 - 277V (±10%) at 60 Hz.
 - 4. Integral short circuit, open circuit, and overload protection.
 - 5. Power Factor: ≥ 0.9.
 - 6. Total Harmonic Distortion: ≤ 20%.
 - 7. Comply with FCC 47 CFR Part 15.
 - 8. Dimming 0-10V
- 2. LED modules shall include the following features unless otherwise indicated:
 - 1. Comply with IES LM-79 and LM-80 requirements.
 - 2. Minimum CRI 80 and color temperature 3500° K unless otherwise specified in LIGHTING FIXTURE SCHEDULE.
 - 3. Minimum Rated Life: 50,000 hours per IES L70.
 - 4. Light output lumens as indicated in the LIGHTING FIXTURE SCHEDULE.
- 3. LED Downlights: Housing, LED driver, and LED module shall be products of the same manufacturer.
- 4. LED Troffers:
 - 1. LED drivers, modules, and reflector shall be accessible, serviceable, and replaceable from below the ceiling.
 - 2. Housing, LED driver, and LED module shall be products of the same manufacturer.

5. Drivers for Dimmer-Controlled Lighting Fixtures:
 1. Dimming Range: 100 to 5 percent of rated lamp lumens.
 2. Driver Input Watts: Can be reduced to 20 percent of normal.
 3. Compatibility: Certified by manufacturer for use with specific dimming control system and lamp type indicated.
 4. Control: Coordinate wiring from ballast to control device to ensure that ballast, controller, and connecting wiring are compatible.

117.4 EXIT SIGNS

- A. General Requirements for Exit Signs: Comply with UL 924; for sign colors, visibility, luminance, and lettering size, comply with authorities having jurisdiction.
- B. Internally Lighted Signs:
 1. Lamps for AC Operation: LEDs, 50,000 hours minimum rated lamp life.

117.5 LIGHTING FIXTURE SUPPORT COMPONENTS

- A. Comply with Division 26 Section "Hangers and Supports for Electrical Systems" for channel- and angle-iron supports and nonmetallic channel and angle supports.
- B. Single-Stem Hangers: **1/2-inch (13-mm)** steel tubing with swivel ball fittings and ceiling canopy. Finish same as fixture.
- C. Twin-Stem Hangers: Two, **1/2-inch (13-mm)** steel tubes with single canopy designed to mount a single fixture. Finish same as fixture.
- D. Wires: ASTM A 641/A 641M, Class 3, soft temper, zinc-coated steel, **12 gage (2.68 mm)**.
- E. Wires for Humid Spaces: ASTM A 580/A 580M, Composition 302 or 304, annealed stainless steel, **12 gage (2.68 mm)**.
- F. Rod Hangers: **3/16-inch (5-mm)** minimum diameter, cadmium-plated, threaded steel rod.
- G. Hook Hangers: Integrated assembly matched to fixture and line voltage and equipped with threaded attachment, cord, and locking-type plug.

PART 118 - EXECUTION

118.1 INSTALLATION

- A. Lighting fixtures: Set level, plumb, and square with ceilings and walls. Install lamps in each fixture.
- B. Comply with NFPA 70 for minimum fixture supports.
- C. Suspended Lighting Fixture Support:

1. Pendants and Rods: Where longer than **48 inches (1200 mm)**, brace to limit swinging.
 2. Stem-Mounted, Single-Unit Fixtures: Suspend with twin-stem hangers.
 3. Continuous Rows: Use tubing or stem for wiring at one point and tubing or rod for suspension for each unit length of fixture chassis, including one at each end.
- D. Adjust aimable lighting fixtures to provide required light intensities.
- E. Connect wiring according to Division 26 Section "Low-Voltage Electrical Power Conductors and Cables."

118.2 FIELD QUALITY CONTROL

- A. Test all light fixtures for normal operation.
- B. Prepare a written report of tests, inspections, observations, and verifications indicating and interpreting results. If adjustments are made to lighting system, retest to demonstrate compliance with standards.

END OF SECTION

SECTION 265568 - EXTERIOR ATHLETIC LIGHTING

PART 119 - GENERAL

119.1 SUMMARY

A. Section Includes:

1. LED Lighting System

B. Work covered by this section of the specifications shall conform to the contract documents, engineering plans as well as state and local codes.

C. The purpose of these specifications is to define the performance and design standards for the City of Lake Elsinore at Rosetta Canyon Sports Park. Manufacturer/contractor shall supply LED lighting equipment to meet or exceed the standards set forth in these specifications.

D. The sports lighting will be for the following fields:

1. Baseball Fields 1 thru 5
2. Football Field

E. The primary goals of this sports lighting project are:

1. Guaranteed Light Levels: Selection of appropriate light levels impact the safety of the players and the enjoyment of spectators. Therefore light levels are guaranteed to not drop below specified target values for a period of 10 years.
2. Environmental Light Control: It is the primary goal of this project to minimize spill light and glare.
3. Life-cycle Cost: In order to reduce the operating budget, the preferred lighting system shall be energy efficient and cost effective to operate. All maintenance costs shall be eliminated, and the field(s) should be proactively monitored to detect luminaire outages over a 10 year life-cycle.
4. Control and Monitoring: To allow for optimized use of labor resources and avoid unneeded operation of the facility, customer requires a remote on/off control system for the lighting system.

LIGHTING PERFORMANCE

F. Illumination Levels and Design Factors: The illumination levels specified shall be based on light levels for 10 years. Light levels shall not drop below specified targeted lighting levels during the specified warranty period. Appropriate light loss factors shall be applied and submitted for the basis of design.

Area of Lighting	Average Light Levels	Max to Min Uniformity Ratio	Grid Points	Grid Spacing
Softball Infield	50 footcandles	2:1	25	20' x 20'
Softball Outfield	30 footcandles	2.5:1	73	20' x 20'
Soccer Field	30 footcandles	2.5:1	72	30' x 30'

- G. Horizontal illumination levels shall be based at any point on a parallel plane 36 inches above the playing surface, unless otherwise indicated. Lighting calculations shall be placed on a grid as shown in the specification.
- H. Mounting Heights: To ensure proper aiming angles for reduced glare and to provide better playability, minimum mounting heights shall be as described below. Higher mounting heights may be required based on photometric report and ability to ensure the top of the field angle is a minimum of 10 degrees below horizontal.

# of Poles	Pole Designation	Pole Height
5	A1 – A5	60'
10	B1 – B10	70'
4	F1 – F4	70'

ENVIRONMENTAL LIGHT CONTROL

- I. Spill Light Control: All luminaires shall utilize spill light and glare control devices including, but not limited to, internal shields, louvers and external shields. No symmetrical beam patterns are accepted.
- J. Spill and Glare Control: Maximum candela viewed from any one fixture shall not exceed 3500 candela at a distance of 150' from the playing field.

LIFE-CYCLE COSTS

- K. Preventative and Spot Maintenance: Manufacturer shall provide all preventative and spot maintenance, including parts and labor for 10 years from the date of equipment shipment. Individual outages shall be repaired when the usage of any field is materially impacted. Owner agrees to check fuses in the event of a luminaire outage.

WARRANTY AND GUARANTEE

- L. 10-Year Warranty: Each manufacturer shall supply a signed warranty covering the entire system for 10 years from the date of shipment. Warranty shall specify light levels; system energy consumption; monitoring, maintenance and control services, spill light control, and structural integrity. Manufacturer shall maintain specifically-funded financial reserves to assure fulfillment of the warranty for the full term. Warranty does not cover weather conditions events such as lightning or hail damage, improper installation, vandalism or abuse, unauthorized repairs or alterations, or product made by other manufacturers.

PART 120 - PRODUCT

SPORTS LIGHTING SYSTEM CONSTRUCTION

- A. Manufacturing Requirements: All components shall be designed and manufactured as a system. All luminaires, wire harnesses, remote drivers, and other enclosures shall be factory assembled, aimed, wired and tested.
- B. Durability: All exposed components shall be constructed of corrosion resistant material and/or coated to help prevent corrosion. All exposed carbon steel shall be hot dip galvanized per ASTM A123. All exposed aluminum shall be powder coated with high performance polyester or anodized. All exterior reflective inserts shall be anodized, coated, and protected from direct environmental exposure to prevent reflective degradation or corrosion. All exposed hardware and fasteners shall be stainless steel of 18-8 grade or better, passivated and coated with aluminum-based thermosetting epoxy resin for protection against corrosion and stress corrosion cracking. Structural fasteners may be carbon steel and galvanized meeting ASTM A153 and ISO/EN 1461 (for hot dipped galvanizing), or ASTM B695 (for mechanical galvanizing). All wiring shall be enclosed within the cross-arms, pole, or electrical components enclosure.
- C. System Description: Lighting system shall consist of the following:
 - 1. Galvanized steel poles and cross-arm assemblies.
 - 2. Non-approved pole technology:
 - A. Any direct bury steel poles or variations of direct buried steel will not be accepted due to potential for internal and external corrosive reaction to the soils and long term performance concerns.
 - 3. Pre-stressed concrete base embedded in concrete backfill allowed to cure for 12-24 hours before pole stress is applied. Alternate may be an anchor bolt foundation designed such that the steel pole and any exposed steel portion of the foundation is located a minimum of 18 inches above final grade. The concrete for anchor bolt foundations shall be allowed to cure for a minimum of 28 days before the pole stress is applied unless shorter cure time approved by structural engineer of record.
 - 4. Fixtures shall have adjustable external visors to control spill light and reduce glare.
 - 5. LED Lamp Technology Sports Lighting Fixtures. Instant on/off capabilities.
 - 6. Fixtures must include thermal management and come with a 10 year full coverage warranty including parts and labor.
 - 7. Minimum of 5,700 Color Temp and 65+ CRI.

8. Fixture Operating Temperature Range of -30 Degrees C to 55 Degrees C. Maximum Junction Temperature for the diodes of 80 degrees C.
 9. Electronic Driver with an efficiency of 95% or greater. Maximum starting inrush of 7 amps at 25 degrees C.
 10. All drivers shall be remote mounted approximately 12-feet above grade-level. Integral drivers will not be accepted.
 11. Secondary Wiring: Manufacturer shall supply all necessary wiring to connect the fixture to the driver enclosure. Wiring shall be protected with either a jacketed cord or conduit and shall be internal to the pole.
 12. Control cabinet to provide remote on-off control and monitoring of the lighting system. Cabinet shall be constructed of aluminum and be rated NEMA Type 4. Communication method shall be provided by manufacturer. Cabinet shall contain custom configured contactor modules for 30, 60, and 100 amps, labeled to match field diagrams and electrical design. Manual off-on-auto selector switches shall be provided.
 13. Manufacturing Requirements: All components shall be designed and manufactured as a system. All luminaires, wire harnesses, drivers and other enclosures shall be factory assembled aimed, wired and tested.
- D. Safety: All system components shall be UL Listed for the appropriate application.
- E. Lightning Protection: Manufacturer shall provide integrated lightning grounding via concrete encased electrode grounding system as defined by NFPA 780 and be UL Listed per UL 96 and UL 96A. If grounding is not integrated into the structure, the manufacturer shall supply grounding electrodes, copper down conductors, and exothermic weld kits. Electrodes and conductors shall be sized as required by NFPA 780. The grounding electrode shall be minimum size of 5/8 inch diameter and 8 feet long, with a minimum of 10 feet embedment. Grounding electrode shall be connected to the structure by a grounding electrode conductor with a minimum size of 2 AWG for poles with 75 feet mounting height or less, and 2/0 AWG for poles with more than 75 feet mounting height.

ELECTRICAL

- F. Electric Power Requirements for the Sports Lighting Equipment.
1. Electric Power: 480V / 3 Phase (refer to electrical plans)
 2. Maximum total voltage drop: Voltage drop to the remote enclosure shall not exceed three (3) percent of the rated voltage.

STRUCTURAL PARAMETERS

- G. All luminaires, visors, and cross-arm assemblies shall withstand 150 mph winds and maintain luminaire aiming alignment
- H. Wind Loads: Wind loads shall be based on the 2016 California Building Code, Chapter 35. Wind loads to be calculated using ASCE 7-05, a design wind speed of 110 mph, Exposure Category C, and wind importance factor of 1.0.
- I. Pole Structural Design: The stress analysis and safety factor of the poles shall conform to 2009 AASHTO Standard Specification for Structural Supports for Highway Signs, Luminaires, and Traffic Signals (LTS-5).

- J. Foundation Design: The foundation design shall be based on soil parameters as outlined in the Geotech Report. If a Geotech Report is not available, foundation design shall be based on soils that meet or exceed those of a Class 5 material as defined by 2016 CBC Table 1806A.2
- K. Foundation Drawings: Project specific foundation drawings stamped by a registered engineer in the state where the project is located are required. The foundation drawings must list the moment, shear (horizontal) force, and axial (vertical) force at ground level for each pole. These drawings must be submitted at time of bid to allow for accurate pricing.

CONTROL SYSTEM

- L. Remote Lighting Control System: System shall allow owner and users with a security code to schedule on/off system operation via a web site, phone, fax or email up to ten years in advance. Manufacturer shall provide and maintain a two-way TCP/IP communication link. Trained staff shall be available 24/7 to provide scheduling support and assist with reporting needs.
 - 1. The owner may assign various security levels to schedulers by function and/or fields. This function must be flexible to allow a range of privileges such as full scheduling capabilities for all fields, to only having permission to execute "early off" commands by phone.
 - 2. Controller shall accept and store 7-day schedules, be protected against memory loss during power outages, and shall reboot once power is regained and execute any commands that would have occurred during outage.
- M. Remote Monitoring System: System shall monitor lighting performance, including on/off status, hours of usage and lamp outages. If luminaire outages that affect playability are detected, manufacturer shall contact owner so that maintenance can be proactively scheduled. The controller shall determine switch position (Manual or Auto) and contactor status (open or closed).
- N. Management Tools: Manufacturer shall provide a web-based database of actual field usage and provide reports by facility and user group.
 - 1. Hours of Usage: Manufacturer shall provide a means of tracking actual hours of usage for the field lighting system that is readily accessible to the owner.
 - a. Cumulative hours: shall be tracked to show the total hours used by the facility
 - b. Current lamp hours: shall be tracked separately to reflect the amount of hours on the current set of lamps being used, so relamping can be scheduled accurately
- O. Communication Costs: Manufacturer shall include communication costs for operating the control and monitoring systems for a period of 10 years.

PART 121 - EXECUTION

SOIL QUALITY CONTROL

- A. It shall be the Contractor's responsibility to notify the Owner if soil conditions exist other than those on which the foundation design is based, or if the soil cannot be readily excavated. Contractor may issue a change order request / estimate for the Owner's approval / payment for additional costs associated with:
 - 1. Providing engineered foundation embedment design by a registered engineer in the State of California for soils other than specified soil conditions;
 - 2. Additional materials required to achieve alternate foundation;
 - 3. Excavation and removal of materials other than normal soils, such as rock, caliche, etc.

DELIVERY TIMING

- B. Equipment On-Site: The equipment must be on-site 6-12 weeks from receipt of approved submittals and receipt of complete order information.

FIELD QUALITY CONTROL

- C. Illumination Measurements: Upon substantial completion of the project and in the presence of the Contractor, Project Engineer, Owner's Representative, and Manufacturer's Representative, illumination measurements shall be taken and verified. The illumination measurements shall be conducted in accordance with IESNA LM-5-04.
- D. Correcting Non-Conformance: If, in the opinion of the Owner or his appointed Representative, the actual performance levels including footcandles and uniformity ratios are not in conformance with the requirements of the performance specifications and submitted information, the Manufacturer shall be required to make adjustments to meet specifications and satisfy Owner.

PART 122 - DESIGN APPROVAL

PRE-BID SUBMITTAL REQUIREMENTS

- A. Approved Product: Musco's Lighting® or approved equal.

END OF SECTION

SECTION 265600 - EXTERIOR LIGHTING

PART 123 - GENERAL

123.1 SUMMARY

A. Section Includes:

1. Exterior luminaires with LED Drivers and Arrays.

123.2 SUBMITTALS

- A. Product Data: For each luminaire and support component, arranged in order of lighting unit designation. Include data on features, accessories, and finishes.

123.3 QUALITY ASSURANCE

- A. Electrical Components, Devices, and Accessories: Listed and labeled as defined in NFPA 70, by a qualified testing agency, and marked for intended location and application.
- B. Comply with IEEE C2, "National Electrical Safety Code."
- C. Comply with NFPA 70.

PART 124 - PRODUCTS

124.1 MANUFACTURERS

- A. Products: Subject to compliance with requirements, provide product indicated on Drawings.

124.2 GENERAL REQUIREMENTS FOR LUMINAIRES

- A. Luminaires shall comply with UL 1598 and be listed and labeled for installation in wet locations by an NRTL acceptable to authorities having jurisdiction.
- B. Lateral Light Distribution Patterns: Comply with IESNA RP-8 for parameters of lateral light distribution patterns indicated for luminaires.
- C. Metal Parts: Free of burrs and sharp corners and edges.
- D. Sheet Metal Components: Corrosion-resistant aluminum unless otherwise indicated. Form and support to prevent warping and sagging.
- E. Housings: Rigidly formed, weather- and light-tight enclosures that will not warp, sag, or deform in use. Provide filter/breather for enclosed luminaires.

- F. Doors, Frames, and Other Internal Access: Smooth operating, free of light leakage under operating conditions, and designed to permit relamping without use of tools. Designed to prevent doors, frames, lenses, diffusers, and other components from falling accidentally during relamping and when secured in operating position. Doors shall be removable for cleaning or replacing lenses. Designed to disconnect ballast when door opens.
- G. Exposed Hardware Material: Stainless steel.
- H. Plastic Parts: High resistance to yellowing and other changes due to aging, exposure to heat, and UV radiation.
- I. Light Shields: Metal baffles, factory installed and field adjustable, arranged to block light distribution to indicated portion of normally illuminated area or field.
- J. Reflecting surfaces shall have minimum reflectance as follows unless otherwise indicated:
 - 1. White Surfaces: 85 percent.
 - 2. Specular Surfaces: 83 percent.
 - 3. Diffusing Specular Surfaces: 75 percent.
- K. Lenses and Refractors Gaskets: Use heat- and aging-resistant resilient gaskets to seal and cushion lenses and refractors in luminaire doors.
- L. Luminaire Finish: Manufacturer's standard paint applied to factory-assembled and -tested luminaire before shipping. Where indicated, match finish process and color of pole or support materials.
- M. Factory-Applied Finish for Steel luminaires: Comply with NAAMM's "Metal Finishes Manual for Architectural and Metal Products" for recommendations for applying and designating finishes.
 - 1. Surface Preparation: Clean surfaces to comply with SSPC-SP 1, "Solvent Cleaning," to remove dirt, oil, grease, and other contaminants that could impair paint bond. Grind welds and polish surfaces to a smooth, even finish. Remove mill scale and rust, if present, from uncoated steel, complying with SSPC-SP 5/NACE No. 1, "White Metal Blast Cleaning," or SSPC-SP 8, "Pickling."
 - 2. Exterior Surfaces: Manufacturer's standard finish consisting of one or more coats of primer and two finish coats of high-gloss, high-build polyurethane enamel.
 - a. Color: As selected by Architect from manufacturer's full range.
- N. Factory-Applied Finish for Aluminum luminaires: Comply with NAAMM's "Metal Finishes Manual for Architectural and Metal Products" for recommendations for applying and designating finishes.
 - 1. Finish designations prefixed by AA comply with the system established by the Aluminum Association for designating aluminum finishes.
 - 2. Natural Satin Finish: Provide fine, directional, medium satin polish (AA-M32); buff complying with AA-M20; and seal aluminum surfaces with clear, hard-coat wax.
 - 3. Class I, Clear Anodic Finish: AA-M32C22A41 (Mechanical Finish: medium satin; Chemical Finish: etched, medium matte; Anodic Coating: Architectural Class I, clear coating 0.018 mm or thicker) complying with AAMA 611.

4. Class I, Color Anodic Finish: AA-M32C22A42/A44 (Mechanical Finish: medium satin; Chemical Finish: etched, medium matte; Anodic Coating: Architectural Class I, integrally colored or electrolytically deposited color coating 0.018 mm or thicker) complying with AAMA 611.

- a. Color: Per architect.

- O. Factory-Applied Labels: Comply with UL 1598. Include recommended lamps and ballasts. Labels shall be located where they will be readily visible to service personnel, but not seen from normal viewing angles when lamps are in place.

1. Label shall include the following lamp and ballast characteristics:

- a. "USES ONLY" and include specific lamp type.

124.3 LED DRIVERS AND ARRAYS

1. Drivers shall accept 120 through 480 volts, 50/60 Hz.
2. The housing shall have an integral thermal management system with extruded aluminum radiation fins and lateral airways.
3. Comply with IES LM-79 and LM-90 Approved Methods.
4. Comply with In-Situ testing for more reliable results.

124.4 GENERAL REQUIREMENTS FOR POLES AND SUPPORT COMPONENTS

- A. Luminaire Attachment Provisions: Comply with luminaire manufacturers' mounting requirements. Use stainless-steel fasteners and mounting bolts unless otherwise indicated.
- B. Mountings, Fasteners, and Appurtenances: Corrosion-resistant items compatible with support components.
 1. Materials: Shall not cause galvanic action at contact points.
 2. Leveling Nuts, Bolt Caps, and Washers: Hot-dip galvanized after fabrication unless otherwise indicated.

PART 125 - EXECUTION

125.1 LUMINAIRE INSTALLATION

- A. Install lamps in each luminaire.
- B. Fasten luminaire to indicate structural supports.
 1. Use fastening methods and materials selected to resist seismic forces defined for the application and approved by manufacturer.
- C. Adjust luminaires that require field adjustment or aiming.

END OF SECTION

SECTION 08 71 00 – EXIT HARDWARE

Door and gate hardware: (All requirements below shall apply to gates as well)

- Doors/doorways as part of an accessible route shall comply with **CBC Sections 11B-404.**
- The clear opening width for a door shall be 32" minimum. For a swinging door it shall be measured between the face of the door and the stop, with the door open 90 degrees. There shall be no projections into it below 34" and 4" maximum projections into it between 34" and 80" above the finish floor or ground. Door closers and stops shall be permitted to be 78" minimum above the finish floor or ground. **CBC Section 11B-404.2.3**
- Handles, pulls, latches, locks, and other operable parts on accessible doors shall comply with **CBC Section 11B-309.4** and shall be operable with one hand and shall not require tight grasping, pinching, or twisting of the wrist. Operable parts of such hardware shall be 34" minimum and 44" maximum above finish floor or ground. Where sliding doors are in the fully open position, operating hardware shall be exposed and usable from both sides. **CBC Section 11B-404.2.7**
- The force for pushing or pulling open a door shall be as follows: **CBC Section 11B-404.2.9.**
 - Interior hinged doors, sliding or folding doors, and exterior hinged doors: **5 pounds (22.2 N)** maximum. Required fire doors: the minimum opening force allowable by the DSA authority, not to exceed **15 pounds (66.7N)**. These forces do not apply to the force required to retract latch bolts or disengage other devices that hold the door in a closed position.
 - The force required for activating any operable parts, such as lever hardware, or disengaging other devices shall be **5 pounds (22.2N)** maximum to comply with **CBC Section 11B-309.4.**
- Door closing speed shall be as follows: **CBC Section 11B-404.2.8**
 - Closer shall be adjusted so that the required time to move a door from an open position of 90 degrees to a position of 12 degrees from the latch is **5 seconds** minimum.
 - Spring hinges shall be adjusted so that the required time to move a door from an open position of 70 degrees to the closed position is **1.5 seconds** minimum.
- Thresholds shall comply with **CBC Section 11B-404.2.5.**
- Floor stops shall not be located in the path of travel and 4" maximum from walls.
- Hardware (including panic hardware) shall not be provided with "Night Latch" (NL) function for any accessible doors or gates unless the following conditions are met: *(Such conditions must be clearly demonstrated and indicated in the specifications)*
 - Such hardware has a 'dogging' feature.
 - It is dogged during the time the facility is open.
 - Such 'dogging' operation is performed only by employees as their job function (non-public use).

SECTION 08 71 00 – EXIT HARDWARE

PART 1 GENERAL

1.1 SECTION INCLUDES

- A. Exit Device Hardware.

1.3 REFERENCES

- A. ANSI A117.1 - Accessible and Useable Buildings and Facilities.
- B. ANSI A156.3 - Door Controls - Exit Devices.

1.4 SUBMITTALS

- A. Omitted.
- B. Product Data: Manufacturer's data sheets on each product to be used, including:
 - 1. Preparation instructions and recommendations.
 - 2. Storage and handling requirements and recommendations.
 - 3. Installation methods.
- C. Shop Drawings: Manufacturer's approved shop drawings are required detailing the application of each product specified.
- D. Selection Samples: For each finish product specified, two full size samples representing manufacturer's full range of available colors and patterns.
- E. Verification Samples: For each finish product specified, two full size samples, representing actual product, color, and patterns.

1.5 QUALITY ASSURANCE

- A. Manufacturer Qualifications: All equipment specified in this section will be provided by a single manufacturer
- B. Installer Qualifications: All products listed in this section are to be installed by a single installer

with experience in installing products of the same type and scope as specified.

- C. Mock-Up: Provide a mock-up for evaluation of surface preparation techniques and application workmanship.
 - 1. Finish areas designated by Landscape Architect.
 - 2. Do not proceed with remaining work until workmanship, color, and sheen are approved by Landscape Architect.
 - 3. Refinish mock-up area as required to produce acceptable work.
- 1.6 DELIVERY, STORAGE, AND HANDLING
- A. Store products in manufacturer's unopened packaging until ready for installation.
 - B. Store and dispose of solvent-based materials, and materials used with solvent-based materials, in accordance with requirements of local authorities having jurisdiction.
- 1.7 PROJECT CONDITIONS
- A. Maintain environmental conditions (temperature, humidity, and ventilation) within limits recommended by manufacturer for optimum results. Do not install products under environmental conditions outside manufacturer's absolute limits.
- 1.8 WARRANTY
- A. At project closeout, provide to the Owner or Owner's Representative an executed copy of the manufacturer's Limited Warranty against Manufacturing Defects.
 - 1. Duration: three_(3) years.
- 1.9 EXTRA MATERIALS
- A. Provide to the Owner two sets of keys for each lock.

PART 2 PRODUCTS

2.1 MANUFACTURERS

- A. Acceptable Manufacturer: Von Duprin an Allegion Brand, which is located at: 11819 N. Pennsylvania St.; Carmel, IN 46032; Toll Free Tel: 877-578-1247.
- B. Substitutions: or approved equal.

2.2 EXIT DEVICES

- A. Rim Devices:
 - 1. 33A Rim Exit Device:
 - A. Latch Bolt: Deadlocking 3/4 inch (19mm) throw.

- B. Dimensions:
2. Center Case: 8 3/16 inches by 2 13/32 inches by 1 9/16 inches (208mm x 62mm x 40mm).
 - 1) Mechanism Case: 2 1/4 inches by 2 1/4 inches (57mm x 57mm).
 - 2) Projection (Maximum): 3 13/16 inches (97mm).
- B. Mortise Lock Devices:
1. 9975 Mortise Lock Device:
 - A. Trim Function: L
 - B. Trim Style: 360L
 - C. Dimensions:
 - 1) Center Case: 8 inches by 2 3/4 inches by 2 3/8 inches (203mm x 70mm x 60mm).
 - 2) Mechanism Case: 2 1/4 inches by 2 1/4 inches (57mm x 57mm).
 - 3) Projection (Maximum): 3 13/16 inches (97mm).

PART 3 EXECUTION

3.1 EXAMINATION

- A. Do not begin installation until substrates have been properly prepared.
- B. If substrate preparation is the responsibility of another installer, notify Architect of unsatisfactory preparation before proceeding.

3.2 PREPARATION

- A. Clean surfaces thoroughly prior to installation.
- B. Prepare surfaces using the methods recommended by the manufacturer for achieving the best result for the substrate under the project conditions.

3.3 INSTALLATION

- A. Install in accordance with manufacturer's instructions.

3.4 PROTECTION

- A. Protect installed products until completion of project.
- B. Touch-up, repair or replace damaged products before Substantial Completion.

3.5 HARDWARE SCHEDULE

- A. 33A/35A Series Hardware Set:
 1. Gates
 2. Components:
 - A. Series: VON DUPRIN 33A
 - B. Device: Rim Device (A)
 - C. Trim Type: Lever (L).
 - D. Trim Style: 360L.
 - E. Lever Type: Style 03.
 - F. Finish: 628, Aluminum, Clear Anodized.
 - G. WH, Weatherized

Fences, gates and hardware:

- Gates that are part of the accessible route shall meet all the requirements of an accessible door in compliance with **CBC Section 11B-404**.
- The levers of lever actuated latches or locks for accessible gates shall be curved with a return to within 1/2" of the gate surfaces to prevent catching on the clothing or persons. **California Referenced Standards Code. T-24 Part 12, Section 12-10-202, Item (F)**.
- Swing doors and gate surfaces within 10" of the finish floor or ground shall have a smooth surface on the push side extending the full width of the door or gate. Parts creating horizontal or vertical joints in these surfaces shall be within 1/16" of the same plane as the other and be free of sharp or abrasive edges. Cavities created by added kick plates shall be capped. **CBC Section 11B-404.2.10**

END OF SECTION 087100

SECTION 12 93 13 - BICYCLE RACKS

PART 1 – GENERAL

1.1 SUMMARY

- A. Section includes: Providing metal bicycle racks where indicated
- B. Related Sections include the following:
 - 1. Omitted.
- C. The bike rack shall be designed and fabricated by AAA Ribbon Bike Rack Co. OR APPROVED EQUAL.

1.2 SUBMITTALS

- A. Omitted.
- B. Product Data: Manufacturer's data for each type of bicycle rack indicated. Include construction details, material descriptions, dimensions of individual components and profiles, finishes, field assembly requirements and installation details.
- C. Manufacturer's installation instructions for information only.

1.3 LEED SUBMITTALS

- A. Credit MRc4.1 and 4.2: Recycled Content:
 - 1. List of proposed materials with recycled content.
 - 2. Product Data or other documentation for each project/material highlighting recycled content information.

1.4 QUALITY ASSURANCE

- A. Manufacturer shall have experience in the manufacturing of metal bicycle racks of the type specified for this Project.
- B. Source Limitations: Obtain each type of bicycle rack through one source from a single manufacturer.
- C. Codes and Standards: Comply with all local building codes.

1.5 PRODUCT DELIVERY

- A. Deliver materials in factory packages with factory labels attached.
- B. Cover and protect material in transit and at job site. Damaged or defaced material will be rejected and replaced at no cost to the Owner.

II PART 2 – PRODUCTS

2.1 MANUFACTURER

- A. Basis of Design for Bicycle Racks: RIBBON® Bike Rack as manufactured by AAA Ribbon Bike Rack Co. OR APPROVED EQUAL.

2.2 MATERIALS

- A. STEEL and IRON

1. Plates, Shapes and Bars: ASTM A36/A 36M. Steel Pipe: Standard weight steel pipe complying with ASTM A53, or electric-resistance-welded pipe complying with ASTM A135.
2. Steel Tubing: Cold-formed steel tubing complying with ASTM A500.
3. Stainless Steel Pipe: Standard weight stainless steel pipe complying with ASTM A312 Type 304
4. Steel Sheet: Commercial steel sheet complying with ASTM A1011.

B. CONCRETE

1. Concrete for foundations: 2,500 psi minimum.

2.3 FABRICATION

- A. Metal Components: Form to required shapes and sizes with true, consistent curves, lines and angles. Separate metals from dissimilar materials to prevent electrolytic action.
- B. Pipes and Tubes: Form simple and compound curves by bending members to jigs to produce uniform curvature for each repetitive configuration required, maintain cylindrical cross section of member throughout entire bend without buckling, twisting, cracking or otherwise deforming exposed surfaces or components.

2.4 BICYCLE RACKS

A. MANUFACTURER

AAA Ribbon Bike Rack Co. OR APPROVED EQUAL

- B. Quantity: as indicated on drawings

Model Number: RB 11 S S

C. CONSTRUCTION

1. Style: RIBBON®
2. Capacity: 11 Bicycles
3. Overall Height (above ground): Nominal 3 feet
4. Overall Length: Nominal 9 feet 2 inches

INSTALLATION

1. Installation: Surface Flange Mount

FINISH

1. Stainless Steel, Satin #4 Finish

MATERIAL

1. Stainless Steel
2. Pipe OD: Minimum 2.375"
3. Pipe Wall Thickness: 0.154"

SECURITY

1. Security: Designed to lock wheel and frame

III PART 3 – EXECUTION

3.1 EXAMINATION

- A. Examine substrates, areas and conditions with installer present, for compliance with requirements for correct and level finished grade, mounting surfaces, installation tolerances and other conditions affecting performance or work.
- B. Proceed with installation only after unsatisfactory conditions have been corrected.

3.2 PREPARATION

- A. Foundation Excavation: Excavate to neat clean lines in undisturbed soil. Remove loose soil and foreign matter from excavation and moisten earth before placing concrete.
- B. Provide forms where required due to unstable soil conditions and for perimeter of pipe base at grade. Secure and brace forms and bicycle rack in position to prevent displacement during concreting. Protect portion of posts above footing from concrete splatter.
- C. Place concrete immediately after mixing. Consolidate concrete in place by using vibrators. Moist-cure exposed concrete for not less than seven days or use non-staining curing compound. Trowel exposed concrete surfaces to a smooth, dense finish, free of trowel marks and uniform in texture and appearance. Provide positive slope for water runoff to perimeter of concrete base.

3.3 INSTALLATION

- A. Comply with manufacturer's written installation instructions, shop drawings, and specifications unless more stringent requirements are indicated.
- B. Install bicycle rack posts plumb, level and square with other work and at the height recommended by the manufacturer.

3.4 FIELD QUALITY CONTROL

- A. Verify that bicycle racks are installed in accordance with manufacturer's instructions.

3.5 CLEANING and PROTECTION

- A. After installation, clean soiled surfaces according to manufacturer's written instructions. Protect bicycle racks from damage until acceptance by Owner.

END OF SECTION 12 93 13

Section 130125 - BLEACHER

NON-ELEVATED ALUMINUM ANGLE FRAME BLEACHERS

PART 1 – GENERAL

1.01 SECTION INCLUDES

- A. Design and fabrication of Non-Elevated angle frame bleachers

1.02 QUALITY ASSURANCE

- A. Distributor: Thepark and Facilities or Approved Equal.
- B. Manufacturer Qualifications: Manufacturer must have experience in the design and manufacturer of bleachers.
- C. Welders must conform to AWS standards.
- D. Source Quality Control: Mill Test Certification.
- E. Codes and Standards: 2012 International Building Code.

1.03 WARRANTY

- A. Warranty shall guarantee bleachers to be free from defect in materials and workmanship for a period of 1 year under normal use. Warranty period shall begin on date of completion for projects installed by manufacturer, or its subcontractors, OR warranty period shall begin on date of final delivery on projects installed by others.
- B. Anodized finish of plank extrusions shall be covered by a 5 year warranty against loss of structural strength or finish deterioration due to exposure to weather conditions or UV rays. Discoloration of mill finish aluminum due to galvanic reaction not covered.

1.04 PRODUCT LIABILITY INSURANCE

- A. Product liability insurance is carried for the life of the product in the amount of \$ 2,000,000.

1.05 ENGINEERING

- A. Engineering certifications and calculations by a Registered Professional Engineer will be provided upon request, for a fee.

PART 2 – PRODUCTS

2.01 ACCEPTABLE DISTRIBUTOR

- A. Thepark and Facilities or approved equal.

2.02 DESIGN

- A. Applicable Codes:
INTERNATIONAL BUILDING CODE (IBC), 2012 EDITION
Except aisle and handicapped requirements
- B. Design Loads:
 - 1. Live Loads: Uniform loading - Structure = 100 psf
Uniform loading - Seat and Foot plank = 120 plf
 - 2. Sway Loads: Perpendicular to seats = 10 plf
Parallel to seats = 24 plf
 - 3. Guardrail Loads: Uniform vertical load = 100 plf

Uniform horizontal load = 50 plf

Concentrated horizontal load = 200 pounds

4. *Wind Loads: Basic design wind speed = 150 mph (exposure "B")

*Note: Bleacher must be anchored to meet wind loads above

2.03 NON-ELEVATED ANGLE FRAME BLEACHERS

A. Quantity and Size: Shall consist of 1 unit(s) 4 rows high x 21 long.

Net seating capacity per unit 37 + 2 ADA seats (excluding aisles, based on 18' per seat).

B. Framework: Prefabricated aluminum angle spaced at 6' - 0" intervals joined by means of aluminum angle cross bracing.

C. Shop connections: Welded to meet AWS standards and local code requirements

NB-051 8APRF

D. Joint Sleeve Assembly: Internal splices, where required shall be two per joint, and shall penetrate the joint a minimum of 8" in each direction and be riveted at one end only to allow for contraction and expansion.

E. Rise and Depth Dimensions: 8" vertical rise and 24" tread depth, Seat height is 17" above its respective tread.

F. Seats: Nominal 2" x 10" anodized aluminum with poly end caps.

G. Treads: Nominal two (2) 2" x 10" mill finish aluminum with anodized end caps on rows 2 & up.

H. Risers: Nominal two (2) 1" x 6" mill finish aluminum with mill finish end caps top on top row Nominal 1" x 6" mill finish aluminum with end caps on rows 4 & up.

I. (1) 4'-0" wide vertical aisle with mid aisle handrail.

J. Guardrail: Vertical picket guardrail system. Rails shall be anodized aluminum tube with end plugs and elbows where required. All Rails shall be secured to angle supports with galvanized fasteners. Top rails at sides, rear and front shall be 42" above the leading edge of seat or walking surfaces. Rear rail support members shall be aluminum channel, side and front rail support s shall be aluminum angle.

2.04 MATERIALS / FINISHES

A. Framework:

1. Aluminum: Structural fabrication with aluminum alloy 6061-T6 mill finish. Each frame shall be unit-welded, using metal inert gas method, under guidelines by the American Welding Society. After fabrication all steel is hot dipped galvanized to ASTM A-1 23 specifications. All crossbracing and horizontal bracing shall be aluminum angle 6061-T6 mill finish.

B. Extruded Aluminum:

1. Seat planks: Aluminum alloy 6063-T6, clear anodized 204R1, AA-M10C22A31, Class II With a wall thickness nominally .078" for impact and deformation resistance.

2. Tread and Riser Planks: Aluminum alloy 6063-T6, mill finish. With a wall thickness nominally 078" for impact and deformation resistance.

3. Guardrail Pipe: 1-5/8 OD schedule 40 aluminum alloy 6105-T5, clear anodized 204R1, AA-M10C22A31, Class II.

C. Accessories:

1. Channel End Caps: Aluminum alloy 6063-T6, clear anodized 204R1, AA-M10C22A31, Class II.

2. Hardware: Bolts and Nuts shall be hot dipped galvanized.

3. Hold Down Clip Assembly: Aluminum alloy 6063-T6 mill finish.

4. Joint Sleeve Assembly: Aluminum alloy 6061-T6, mill finish.

PART 3 – EXECUTION

3.01 INSTALLATION

A. Install bleacher unit in accordance with manufacturer written instructions and shop drawings. Note: Building codes may vary from site to site. The customer is responsible for verification of local code requirements.

Grandstands and bleachers:

- Provide accessible seating per the seating requirements CBC Section 11B-221.

Assistive-listening Systems

- Assistive-listening systems shall be provided in accordance with **CBC Section 11B-219** and shall comply with **CBC Section 11B-706**.
- The minimum number of receivers to be provided shall be equal to 4% of the total number of seats, but in no case less than two. 25 % minimum of receivers provided, but no fewer than two, shall be hearing-aid compatible in accordance with **CBC Section 11B-706.3**.
- If the system provided is limited to specific areas or seats, then such areas or seats shall be within a 50-foot viewing distance of, and have a complete view of, the stage or playing area. **CBC Section 11B-219.4**

(Show plan reviewer the types of assistive-listening systems.)

END OF SECTION

SECTION 13 31 23 - PRE-ENGINEERED FABRIC SHADE STRUCTURES

PART 1 – GENERAL

1.1 RELATED DOCUMENTS

- A. Drawings and general provisions of the Contract, including General Conditions and Division 1 Specification Sections, apply to this section.

1.2 SUMMARY

- A. A single, State of California-licensed fabric shade structure contractor shall be responsible for the design, wet-stamped engineering drawings, permitting, fabrication, supply, and erection of the work specified herein, including foundations. The intent of this specification is to have only one shade contractor be responsible for all of the functions listed above.

1.3 SUBMITTALS

1.3.1 With Bid Submittals:

- A. Provide proof of existing reference sites with structures of similar project scope and scale, and engineered to the specified CBC requirements.
- B. Provide a minimum of 7 fabric samples to demonstrate fabric color range, and a digital (PDF) or paper document showing a minimum of 9 powder coat color choices. Also, provide a letter of authorization from the fabric manufacturer delineating authorized use of the specified fabric.
- C. Provide proof of all quality assurance items, including;
 - 1. A list of at least 3 reference projects of similar scope in California.
 - 2. Proof of General Liability, Professional Liability, and Umbrella insurance, as per Section 1.4C.
 - 3. Proof of current State of California Contractor's License, Class A or Class B.
 - 4. Proof of current City of Los Angeles Approved Fabricator license.
 - 5. Proof of a total minimum of \$25,000,000 aggregate bonding capacity.
 - 6. Proof of current IAS certification, as per Section 1.4E.
 - 7. Proof of an Annual Maintenance Inspection Program.
 - 8. Proof of a Corporate Safety and/or Injury & Illness Prevention Program.
 - 9. Proof of current status as an ISNetwork Member Contractor.

1.4 QUALITY ASSURANCE

Fabrication and erection are limited to firms with proven experience in the design, fabrication, and erection of fabric shade structures, and such firms shall meet the following minimum requirements. No substitutions shall be allowed for the following:

- A. A single shade structure contractor shall design, engineer, manufacture, and erect the fabric shade structures, including the foundations, and shall provide a dedicated Project Manager throughout the entire Scope of Work related to the shade structure(s).
- B. All bidders shall have _____ experience in the design, engineering, manufacture, and erection of fabric shade structures, engineered to California Building Code requirements with similar scope, and a successful construction record of in-service performance.
- C. Omitted.
- D. Omitted.
- E. Manufacturer shall have a City of Los Angeles Approved Fabricator license and be accredited by the IAS (International Accreditation Service) for Structural Steel Fabrication under CBC specified requirements.
- F. The fabric shade structure contractor shall have a Corporate Quality Control program (manual), which describes their complete quality assurance program.
- G. All bidders must be a current Member Contractor with ISNetworld, which confirms the bidder's strict adherence to Safety, Insurance, Quality, and Regulatory standards.

1.5 PROJECT CONDITIONS

- A. Field Measurements: Verify layout information for fabric shade structure(s) shown on the drawings in relation to the property survey and existing structures, and verify locations by field measurements prior to erection of the fabric shade structure(s).

1.6 WARRANTY

- A. The successful bidder shall provide a 12-month warranty on all labor and materials.
- B. A supplemental warranty from the manufacturer shall be provided for a period of 10 years (pro-rated) on fabric and 10 years on the structural integrity of the steel, from date of substantial completion.

- C. The warranty shall not deprive the Owner of other rights the Owner may have under the provisions of the Contract Documents, and will be in addition to and run concurrent with other warranties made by the Contractor under requirements of the Contract Documents.

PART 2 – PRODUCTS

2.1 GENERAL

Scope: Proposal shall include the provision and installation of one (1) shade structure as described herein:

- A. Structure shall consist of three (3) joined four-point “hypar” sails made of Monotec 379 FR series fabric, and connected via eight steel columns.
 - 1. The diameter and thickness of each of the eight (8) steel columns shall range in size to support the varying entry heights and tension of the sails.
 - a. Two columns shall be a minimum of HSS10.75 x .365, four columns shall be a minimum HSS14 x .375, and two columns shall be a minimum of HSS16 x 3.75
 - b. Column length must extend at least 1’ above tallest entry height’s connection point
 - c. Column length must include at least 3’ of steel to be placed below ground for a “pole in hole” installation
 - 2. All steel shall be standard galvanized and powder coated.
 - 3. 0.5” (nominal) galvanized 7x19 strand cable shall be used.
 - 4. All hardware and cabling shall be standard galvanized. No exceptions
- A. The structures shall be manufactured by Shade Structures, Inc., d/b/a USA SHADE & Fabric Structures, or approved equal include the engineering drawings, fabric roof, steel cables, all fasteners, and erection of structure(s), including foundations.
- B. Contact: USA SHADE & Fabric Structures or Approved Equal
- C. To qualify as an approved equal, please submit product documentation, fabric samples, and all quality assurance criteria, as per Section 1.4, at least 10 days prior to bid in order to be considered. No substitutions will be allowed after the deadline. Any approval of alternate manufacturers shall be by addendum prior to the bid date and shall not be allowed without written notification.
- D. The fabric shade structure(s) shall conform to the CBC 2016 version of the California Building Code.
- E. All fabric shade structures are designed and engineered to meet the minimum of 115mph Wind Load, Risk Category II, Exposure C, and Seismic (earthquake) Load based on Seismic Design Category D, Seismic Risk Category II, and a Live Load of 5psf. All fabric shade structures shall be engineered with a zero wind pass-through factor on the fabric. When ASD Steel Design Method is used based on CBC Section 1605.3.1, the load combinations Dead Load + 0.75 Live load + 0.75 Wind Load, and 0.6 Dead Load + Wind Load must be analyzed. NO EXCEPTIONS.

F. Steel:

1. All steel members of the fabric shade structure shall be designed in strict accordance with the requirements of the "American Institute of Steel Construction" (AISC) Specifications and the "American Iron and Steel Institute" (AISI) Specifications for Cold-Formed Members and manufactured in a IAS- (International Accreditation Service) accredited facility for Structural Steel Fabrication under CBC Section 1704.2.5.2.
2. All connections shall have a maximum internal sleeving tolerance of .0625" using high-tensile strength steel sections with a minimum sleeve length of 6".
3. All non-hollow structural steel members shall comply to ASTM A-36. All hollow structural steel members shall be cold-formed, high-strength steel and comply with ASTM A-500, Grade C. All steel plates shall comply with ASTM A-572, Grade 50. All galvanized steel tubing shall be triple-coated for rust protection using an in-line electroplating coat process. All galvanized steel tubing shall be internally coated with zinc and organic coatings to prevent corrosion.

G. Bolts:

1. All structural field connections of the shade structure shall be designed and made with high-strength bolted connections using ASTM A-325, Grade B or SAE J249, Grade 8.
2. Where applicable, all stainless steel bolts shall comply with ASTM F-593, Alloy Group 1 or 2. All bolt fittings shall include rubber washers for water-tight seal at the joints. All nuts shall comply with ASTM F-594, Alloy Group 1 or 2.

H. Welding:

1. All shop-welded connections of the fabric shade structure shall be designed and performed in strict accordance with the requirements of the "American Welding Society" (AWS) Specifications. Structural welds shall be made in compliance with the requirements of the "pre-qualified" welded joints, where applicable and by certified welders. No onsite or field welding shall be permitted.
2. All full penetration welds shall be continuously inspected by an independent inspection agency and shall be tested to the requirement of specified CBC requirements.

I. Powder Coating:

1. Galvanized steel tubing preparation prior to powder coating shall be executed in accordance with solvent cleaning SSPC-SP1. Solvents such as water, mineral spirits, xylol, and toluol, which are to be used to remove foreign matter from the surface. A mechanical method prior to solvent

cleaning, and prior to surface preparation, shall be executed according to Power Tool Cleaning SSPC-SP3, utilizing wire brushes, abrasive wheels, needle gun, etc.

2. Carbon structural steel tubing preparation prior to powder coating shall be executed in accordance with commercial blast cleaning SSPC-SP6 or NACE #3. A commercial blast cleaned surface, when viewed without magnification, shall be free of all visible oil, grease, dirt, mill scale, rust, coating, oxides, corrosion, and other foreign material.
 3. Powder coating shall be sufficiently applied (minimum 3 mils thickness) and cured at the recommended temperature to provide proper adhesion and stability to meet salt spray and adhesion tests, as defined by the American Society of Testing Materials.
 4. Raw powder used in the powder coat process shall have the following characteristics:
 - a. Specific gravity: 1.68 +/- 0.05
 - b. Theoretical coverage: 114 +/- 4ft²/mil
 - c. Mass loss during cure: <1%
 - d. Maximum storage temperature: 80°F
 - e. Interpon[®] 800 is a high-durability TGIC powder coating designed for exterior exposure. Tested against the most severe specifications, Interpon[®] 800 gives significantly improved gloss retention and resistance to color change.
- K. Tension Cable: Steel cable is determined based on calculated engineering loads.
1. For light and medium loads, 0.25" (nominal) galvanized 7x19 strand cable shall be used.
 2. For heavy loads, and depending on structural size, either 0.375" (nominal) or 0.5" (nominal) galvanized 7x19 strand cable shall be used.
- L. Fabric Roof Systems:
1. UV Shade Fabric:
 - a. Monotec 370[®] FR Series UV shade fabric is made of a UV-stabilized, high-density polyethylene (HDPE) round yarn, as manufactured by Pro-Knit Industries[®] (Pty) Ltd.:
 - i. HDPE mesh shall be heat-seal and absolutely no tape yarn shall be used.
 - ii. Raw fabric rolls shall be no less than 3.25 meters wide to help reduce unsightly seams, weak points, and fabrication costs.
 - iii. UV protection as per AS4174-1994
 - iv. Fabric Warranties:
 - ~ 10 year UV Warranty
 - ~ 10 year "under tension" warranty
 - v. Fabric shall have passed the following flame spread and fire propagation tests:

- ASTM E-84 Class A
- NFPA 701
- California's Office of the State Fire Marshal Marshall Title 19, 1237.1 (1993)

PART 3 – EXECUTION

3.1 INSTALLATION

- A. The installation of fabric shade structures shall be performed by manufacturer or manufacturer-approved contractor, which shall be bonded and holding a current contractor's license with the State of California's Contractors State License Board. All installation personnel must have experience in the erection of tensioned fabric structures.
- B. The installation shall comply with the manufacturer's instructions for assembly, installation and erection, per approved drawings.
- C. Concrete:
 1. Unless noted otherwise for footings and piers by the Project Engineer, the concrete specification for footings and/or piers shall meet a minimum 3,000psi at 28-day strength.
 2. Concrete work shall be executed in accordance with the latest edition of American Concrete Building Code ACI 318-14.
 3. Concrete specifications shall comply in accordance with the Section 03300 Cast-in- Place Concrete, detailed as per plans, and shall be as follows:
 - a. 28 Days Strength $F'c = 3000$ psi
 - b. Aggregate: HR
 - c. Slump: 3 ~ 5 inch
 - d. Portland Cement shall conform to C-150
 - e. Aggregate shall conform to ASTM C-33
 4. All reinforcement shall conform to ASTM A-615 grade 60.
 5. Reinforcing steel shall be detailed, fabricated, and placed in accordance with the latest ACI Detailing Manual and Manual of Standard Practice.
 6. Whenever daily ambient temperatures are below 80 degrees Fahrenheit, the contractor may have mix accelerators and hot water added at the batch plant (See Table 1).
 7. The contractor shall not pour any concrete when the daily ambient temperature is to be below 55 degrees Fahrenheit.

TABLE 1

4	Temperature Range	5	% Accelerator	6	Type Accelerator
7	75~80 degrees F	8	1%	9	High Early (non calcium)
10	70~75 degrees F	11	2%	12	High Early (non calcium)
13	Below 70 degrees F	14	3%	15	High Early (non calcium)

D. Foundations:

1. Drilled-pier footings and full rebar cages shall be drilled, set, and poured as per manufacturer’s specifications.
 - a. The fabric shade structure proposed herein shall be proposed with eight (8) drilled-pier foundations; two (2) shall have a minimum footing of 30” x 10’ and six (6) shall have a minimum footing of 30” x 12’, with full rebar cage, as per final approved manufacturer’s engineered specifications and drawings.

END OF SECTION 13 31 23

SECTION 32 15 40

DG SURFACING

GENERAL

1. RELATED DOCUMENTS

Drawings and general provisions of the Contract, including General and Supplementary Conditions and Division 01 Specification Sections, apply to this Section.

2. SUMMARY

Section includes decomposed granite surfacing.

3. INFORMATIONAL SUBMITTALS

Material Certificates: Signed by suppliers certifying that each material complies with requirements.

PRODUCTS

4. DECOMPOSED GRANITE

Decomposed Granite: Igneous rock which has weathered in place or any sedimentary material principally derived from igneous rock. Provide washed material free of organic material and other deleterious substances.

Material shall be C-35 Not Defined. Conform to the following gradation as determined by ASTM C 136:

<u>Sieve Size</u>	<u>Percent Passing</u> (by weight)
3/8 inch	100
No. 4	100
No. 8	93
No. 16	65
No. 30	44
No. 50	28
No. 100	16
No. 200	8.7
Resistance "R" value	82%
Sand equivalent value	61%

5. Stabilizer

A. Stabilizer Solutions "Stabilizer" or approved equal.

B. Batch mix at plant prior to delivery to site.

EXECUTION

6. EXAMINATION

Verify that subgrade is dry and in suitable condition to support surfacing and imposed loads. Compact subgrade to 90%.

Do not begin decomposed granite surfacing installation until unsatisfactory conditions have been corrected.

7. PREPARATION

Proof-roll subgrade using heavy, pneumatic-tired rollers to locate areas that are unstable or that require further compaction.

8. INSTALLATION OF EDGINGS

Concrete Mowing Strip per City of San Diego Standard Drawing SDL-103.

9. INSTALLATION OF DECOMPOSED GRANITE SURFACING

Thoroughly pre-mix stabilizer into stock piled dry decomposed granite with approved mechanical blending unit, following manufacturer's specifications. Place surfacing material at optimum moisture content to required grades, lines, cross sections, and thickness to not less than 95 percent of maximum dry unit weight according to ASTM D 1557. Shape material to required crown elevations and cross-slope grades. Place materials in a single layer. Compacted thickness shall be 4 inches minimum. Water decomposed granite surfacing to activate stabilizer per manufacturer's specifications. Compact surfacing with 5 ton rollers or using other equipment acceptable to Construction Manager. Compact with hand tampers in areas inaccessible to rollers. Do not use vibratory plate compactors. Examine surface immediately after rolling for indicated crown, grade, and smoothness. Adjust surfaces as required, and reroll to obtain smoothness and required elevations. Protection: After final rolling, do not permit vehicular traffic on surfacing.

10. INSTALLATION TOLERANCES

Thickness: Compact to produce the thickness indicated within the following tolerances:
Surface Course: Plus 1/4 inch, no minus. Surface Smoothness: Compact to produce a surface smoothness within the following tolerances as determined by using a 10-foot straightedge applied transversely or longitudinally to surfaced areas: Surface Course: 1/4 inch (6 mm).

END OF SECTION 32 15 40

SECTION 32 18 23 – INFIELD SURFACING

PART 1: GENERAL

1.1 Section Includes

A. Section Includes: Supply and installation of a complete infield skin surface, including pitcher's mound, batter's box, and warning track mixes including:

1. PROGold Premium Infield Mix or Approved Equal

1.2 Related Sections

1.3 References

- A. ASTM F-1632: Standard Test Method for Particle Size Analysis
- B. ASTM D- 422: Standard Test Method for Fine Particle Size Analysis

1.4 Submittals

A. Submit the following:

1. Manufacturer's product data sheet and installation instructions for each product to be used.
2. 5 pound sample for each product to be used along with a private lab test indicating the particle size analysis of the material. All tests shall be performed in accordance with ASTM F-1632.
3. Manufacturer's maintenance and cleaning instructions for each product to be used.

1.5 Project / Site Conditions

- A. All Earthwork shall be performed in accordance with the preceding sections.
- B. Sub base material shall be uniformly graded and compacted, and shall mirror finish grade contours to ensure an even depth of material.
- C. Survey subgrade elevations prior to placement of material.
- D. Construct skin surfaces with a finish grade that provides adequate surface drainage, ideally 0.5 to 1.5% slope away from the center of the infield.

PART 2: PRODUCTS

SPECIFIER NOTE:

2.1 Materials

- A. PROGold Premium Infield Mix
Premium Warning Track Mix engineered soil products produced by Gail Materials or Approved Equal.

B. PROGold Premium Infield Mix:

1. Gradation: A minimum of 98% of particles shall pass the 2.00 mm sieve with the highest portion of sand particles in the medium to very fine range. Silt and Clay distribution shall be relatively equal with the ratio of silt to clay .5 – 1.2. The final soil classification based on USDA criteria shall be a “sandy loam – sandy clay loam”.
2. Color: “Gold”.

C. PROGold Premium Mound and Homeplate Mix

1. Gradation: Minimum clay content of 38% by weight as determined by ASTM D422 methodology.
2. Color: “Grey”, “Tan”, “Brown”, “Red” or “Reddish Brown”.

D. PRO Gold Premium Warning Track Mix

1. Gradation: 50-75% crushed-screen 3/16 inch minus decomposed granite fines and 25-50% Cinder Sand.
Sieve Percent Passing:
3/16” 95 - 100%
No. 4 90-100%
No. 30 25-60%
No. 200 5-20%
2. Binder: Natracil™ organic binder by Gail Materials or Approved Equal. Binder shall have a minimum swell volume of 35 ml/gm and shall be blended with a pug mill that includes a weight belt feeder that insures the proper ratio and the uniform blending of the binder. Bucket of Belt blending are not acceptable methods.
3. Color: “Gold”.

PART 3: EXECUTION

3.1 Placement

A. Infield surfacing shall be installed in strict conformance with the manufacturer’s specifications to the lines and grades as shown in the Drawings.

B. New Fields: Place material to a final minimum depth of 4 inches when finished and compacted.

The final grade should be leveled and sloped according to standard infield construction specifications. Allow for +/- 1 inch for compaction.

3.2 Watering

A. After leveling the infield skin thoroughly water the entire infield surface until the complete depth of the infield mix is moistened. After a period of +/- 4 hours compact with a minimum 2000 lb static drum roller. If low areas are present, scarify and level low areas with additional infield mix.

3.3 Inspection

A. The finished surface of the infield shall be smooth and free from any visible dips, humps, bumps for other blemishes which would hinder the removal of water through positive surface drainage. Correct irregularities to the satisfaction of the Landscape Architect.

3.4 Topdressing

A. Following successful inspection, topdressing may be applied, consisting of a calcified clay product added at a rate of one 50-pound bag per 100 square ft.

END OF SECTION 32 18 23

SECTION 32 33 43 – BENCHES

PART 1 – GENERAL

1.1 SUMMARY

- A. PRE-CAST CONCRETE SITE FURNISHING

1.2 REFERENCES

- A. Architectural Precast Association (APA).
- B. ASTM

1.3 SUBMITTALS

- A. Product Data: Submit product data for manufactured materials and products.
- B. Shop Drawing
 - 1. Show in-place location, fabrication details, plans, elevations, anchorages, reinforcement, connection details and methods, dimensions, finishes, relationships to adjacent materials, and erection and placement.
- C. Samples: Nominal size 6” sq. by appropriate thickness, of each type of unit and finished facing shown and specified for approval of quality, color, and texture of surface finish. Submit prior to fabrication.
- D. Mix Design(s): Proposed concrete mix design for each type and color of concrete mix.
- E. Test Reports: Compressive Strength. Supply 12 test results from the last year showing the required results of 5000 PSI.

1.4 QUALITY ASSURANCE

- A. Fabricator’s Qualifications: Firm shall have experience in producing units similar to those required for this Project, with sufficient production capacity to produce and deliver required units without causing delay in Work.
- B. Has a quality control program that is comparable to APA or PCI that is certified by a professional engineer. Must submit program with bid.

1.5 DELIVERY, STORAGE, AND HANDLING

- A. Deliver units to the Project site in such quantities and at such times to ensure continuity of installation.
- B. Deliver on a truck owned by the manufacturer. Truck to have a crane or a forklift for placement. Driver to be trained to use applicable equipment. Placement where possible. Contractor to place product not reachable by manufacturer’s equipment.

PART 2 – PRODUCTS

2.1 MANUFACTURERS

- A. Approved Fabricators:
 - 1. Quick Crete Products Corp. or Approved Equal.

2. Fabricators not listed as approved shall request approval. Approval request must be sent to the owner 30 days before bid opening. Request must include drawings, color samples, and an actual product for review by owner. **Approved Fabricator must ship on company owned trucks equipped with a crane or forklift for off-loading product.**

2.2 MATERIALS

A. Concrete Materials:

1. Portland Cement: ASTM C 150, Type I(white) or III (gray), to achieve desired finish colors. Use only one brand, type, and color from the same mill.
2. Aggregates: ASTM C 33, gradation may differ to achieve desired finish characteristics. Select coarse and fine aggregate colors and screen sizes to match approved sample(s). Verify that adequate supply, from one pit or quarry, for each type of aggregate is available for the entire Project. If possible obtain entire aggregate supply prior to starting Work, or have aggregate supply held in reserve by aggregate supplier.
3. Water: Potable. Clean, clear, and free from deleterious amounts of salts, acids, alkali's, organic materials, oils, detergents, or other matter that may interfere with color, curing, or strength of concrete.
4. Premium Select Ipe wood
5. Powder Coated Steel Brackets: Coated applied electrostatically and cured under heat for a tougher than conventional paint application.
6. Admixtures: Select to be compatible in specified mix.
 - a) Air Entraining: ASTM C 260.
 - b) Water Reducing: ASTM C 494, Type A,B,C,F. or G.
 - c) Coloring Agent: ASTM C 979, compatible with other concrete materials.

B. Formwork:

1. Provide forms with acceptable form facing materials that are non-reactive with concrete or form release agents and will produce required finish surfaces.
2. Construct and maintain forms to produce precast concrete units of shapes, lines, and dimensions indicated, within specified tolerances.

B. Reinforcing Materials:

1. Reinforcing Bars: ASTM A 615, Grade 40

2.3 MIXES

- A. Design mixes for each type of concrete specified may be prepared by an independent testing agency or by architectural precast manufacturing plant personnel at precast fabricator's option.
- B. Proportion mixes by either testing agency trial batch or field test data methods in accordance with ACI 211.1, using materials to be used on the project, to provide normal weight concrete with properties as follows:
 1. Compressive Strength: 5,000 psi when tested in accordance with ASTM C 39.
 2. Maximum water cement ratio 0.47 at point of placement.
 3. Add air-entrainment admixture to result in air content at point of placement complying with ACI 533 requirements.
 4. List other admixtures and recommended quantities.

2.4 FABRICATION

- A. General:
 - 1. Fabricate precast concrete units with manufacturing and testing procedures, quality control recommendations, and dimensional tolerances as specified in ACI 533, unless more stringent requirements are shown or specified.
 - 2. Fabricate units straight, smooth and true to size and shape, with exposed edges and corners precise and square, unless otherwise indicated.
- B. Reinforcement: Comply with CRSI "Manual of Standard Practice" and ACI 318 recommendations. Reinforce architectural precast concrete units to resist handling, transportation stresses, and to comply with specified performance criteria.
- C. Comply with ACI-533 requirements for measuring, mixing, transporting, and placing concrete.
- D. Consolidate concrete using equipment and procedures complying with ACI 533.
- E. Discard units that are warped, cracked, broken, spalled, stained, or otherwise defective unless repairs are approved by the Owner and meet specified requirements.
- F. Fabrication Tolerances: Fabricate to tolerances listed in ACI-533.

END OF SECTION 32 33 43

SUPPLEMENTARY SPECIAL PROVISIONS
APPENDICES

APPENDIX A
NOTICE OF EXEMPTION

NOTICE OF EXEMPTION

(Check one or both)

TO: Recorder/County Clerk
P.O. Box 1750, MS A-33
1600 Pacific Hwy, Room 260
San Diego, CA 92101-2400

FROM: City of San Diego
Public Works Department
525 B Street, Suite 750, MS 908A
San Diego, CA 92101

Office of Planning and Research
1400 Tenth Street, Room 121
Sacramento, CA 95814

Project Name: Wangenheim Joint Use Facility

Project / WBS No.: 616806/S-15007.02.06

Project Location-Specific: The project is located within the Walker-Wangenheim School Park bound by the Walker Elementary School and Walker Neighborhood Park to the north, residential uses on Westchester Avenue, Caminito Westchester, and Caminito Derecho to the west, Black Mountain Road to the east, and Wangenheim Middle School at 9230 Gold Coast Drive to the south. The proposed project is within the Mira Mesa Community Planning area, Council District 6.

Project Location-City/County: San Diego/San Diego

Description of nature and purpose of the Project: The project proposes construction to expand the existing 11-acre joint use facility at Wangenheim Middle School by 4-acres to supplement existing park acreage in the Mira Mesa community. Improvements to the joint use areas will include two new natural turf playfields, bleachers, and LED sports and field lighting to be added along Black Mountain Road on the northeast section of the park. Additional improvements would include a new 830 square foot comfort station/family restroom, new shade sails over the existing tot lot, monument signage, fencing, gates, screening trees, and traffic signal modifications to the existing signalized intersection at Miramar College Drive and Black Mountain Road.

Name of Public Agency Approving Project: City of San Diego

Name of Person or Agency Carrying Out Project: Gretchen Eichar, 525 B Street, Suite 750, San Diego, CA, 92101, (619) 533-4110

Exempt Status: (CHECK ONE)

- Ministerial (Sec. 21080(b)(1); 15268);
- Declared Emergency (Sec. 21080(b)(3); 15269(a));
- Emergency Project (Sec. 21080(b)(4); 15269 (b)(c))
- Categorical Exemption: 15303 (New Construction or Conversion of Small Structures) and 15304 (Minor Alterations to Land)

Reasons why project is exempt: The City of San Diego conducted an environmental review which determined that the project meets the categorical exemption criteria set forth in CEQA State Guidelines, Section 15303 (New Construction or Conversion of Small Structures), which allows for construction and location of limited numbers of new, small facilities or structures; Section 15304 (Minor Alterations of Land), which allows minor public alterations in the condition of land, water, and/or vegetation which do not involve the removal of healthy, mature, scenic trees, including trenching and backfilling where the surface is restored; and where the exceptions listed in Section 15300.2 would not apply.

Lead Agency Contact Person: Gretchen Eichar

Telephone: (619) 533-4110

Revised May 2016

If filed by applicant:

1. Attach certified document of exemption finding.
2. Has a notice of exemption been filed by the public agency approving the project? () Yes () No

It is hereby certified that the City of San Diego has determined the above activity to be exempt from CEQA



Carrie Purcell, Assistant Deputy Director

2/25/19
Date

Check One:

- Signed By Lead Agency
 Signed by Applicant

Date Received for Filing with County Clerk or OPR:

APPENDIX B
FIRE HYDRANT METER PROGRAM

CITY OF SAN DIEGO CALIFORNIA DEPARTMENT INSTRUCTIONS	NUMBER DI 55.27	DEPARTMENT Water Department
SUBJECT FIRE HYDRANT METER PROGRAM (FORMERLY: CONSTRUCTION METER PROGRAM)	PAGE 1 OF 10	EFFECTIVE DATE October 15, 2002
	SUPERSEDES DI 55.27	DATED April 21, 2000

1. **PURPOSE**

- 1.1 To establish a Departmental policy and procedure for issuance, proper usage and charges for fire hydrant meters.

2. **AUTHORITY**

- 2.1 All authorities and references shall be current versions and revisions.
- 2.2 San Diego Municipal Code (NC) Chapter VI, Article 7, Sections 67.14 and 67.15
- 2.3 Code of Federal Regulations, Safe Drinking Water Act of 1986
- 2.4 California Code of Regulations, Titles 17 and 22
- 2.5 California State Penal Code, Section 498B.0
- 2.6 State of California Water Code, Section 110, 500-6, and 520-23
- 2.7 Water Department Director

Reference

- 2.8 State of California Guidance Manual for Cross Connection Programs
- 2.9 American Water Works Association Manual M-14, Recommended Practice for Backflow Prevention
- 2.10 American Water Works Association Standards for Water Meters
- 2.11 U.S.C. Foundation for Cross Connection Control and Hydraulic Research Manual

3. **DEFINITIONS**

- 3.1 **Fire Hydrant Meter:** A portable water meter which is connected to a fire hydrant for the purpose of temporary use. (These meters are sometimes referred to as Construction Meters.)

CITY OF SAN DIEGO CALIFORNIA DEPARTMENT INSTRUCTIONS	NUMBER DI 55.27	DEPARTMENT Water Department
SUBJECT FIRE HYDRANT METER PROGRAM (FORMERLY: CONSTRUCTION METER PROGRAM)	PAGE 2 OF 10	EFFECTIVE DATE October 15, 2002
	SUPERSEDES DI 55.27	DATED April 21, 2000

- 3.2 **Temporary Water Use:** Water provided to the customer for no longer than twelve (12) months.
- 3.3 **Backflow Preventor:** A Reduced Pressure Principal Assembly connected to the outlet side of a Fire Hydrant Meter.

4. **POLICY**

- 4.1 The Water Department shall collect a deposit from every customer requiring a fire hydrant meter and appurtenances prior to providing the meter and appurtenances (see Section 7.1 regarding the Fees and Deposit Schedule). The deposit is refundable upon the termination of use and return of equipment and appurtenances in good working condition.
- 4.2 Fire hydrant meters will have a 2 ½" swivel connection between the meter and fire hydrant. The meter shall not be connected to the 4" port on the hydrant. All Fire Hydrant Meters issued shall have a Reduced Pressure Principle Assembly (RP) as part of the installation. Spanner wrenches are the only tool allowed to turn on water at the fire hydrant.
- 4.3 The use of private hydrant meters on City hydrants is prohibited, with exceptions as noted below. All private fire hydrant meters are to be phased out of the City of San Diego. All customers who wish to continue to use their own fire hydrant meters must adhere to the following conditions:
 - a. Meters shall meet all City specifications and American Water Works Association (AWWA) standards.
 - b. Customers currently using private fire hydrant meters in the City of San Diego water system will be allowed to continue using the meter under the following conditions:
 - 1. The customer must submit a current certificate of accuracy and calibration results for private meters and private backflows annually to the City of San Diego, Water Department, Meter Shop.

CITY OF SAN DIEGO CALIFORNIA DEPARTMENT INSTRUCTIONS	NUMBER DI 55.27	DEPARTMENT Water Department
SUBJECT FIRE HYDRANT METER PROGRAM (FORMERLY: CONSTRUCTION METER PROGRAM)	PAGE 3 OF 10	EFFECTIVE DATE October 15, 2002
	SUPERSEDES DI 55.27	DATED April 21, 2000

2. The meter must be properly identifiable with a clearly labeled serial number on the body of the fire hydrant meter. The serial number shall be plainly stamped on the register lid and the main casing. Serial numbers shall be visible from the top of the meter casing and the numbers shall be stamped on the top of the inlet casing flange.
3. All meters shall be locked to the fire hydrant by the Water Department, Meter Section (see Section 4.7).
4. All meters shall be read by the Water Department, Meter Section (see Section 4.7).
5. All meters shall be relocated by the Water Department, Meter Section (see Section 4.7).
6. These meters shall be tested on the anniversary of the original test date and proof of testing will be submitted to the Water Department, Meter Shop, on a yearly basis. If not tested, the meter will not be allowed for use in the City of San Diego.
7. All private fire hydrant meters shall have backflow devices attached when installed.
8. The customer must maintain and repair their own private meters and private backflows.
9. The customer must provide current test and calibration results to the Water Department, Meter Shop after any repairs.
10. When private meters are damaged beyond repair, these private meters will be replaced by City owned fire hydrant meters.

CITY OF SAN DIEGO CALIFORNIA DEPARTMENT INSTRUCTIONS	NUMBER DI 55.27	DEPARTMENT Water Department
SUBJECT FIRE HYDRANT METER PROGRAM (FORMERLY: CONSTRUCTION METER PROGRAM)	PAGE 4 OF 10	EFFECTIVE DATE October 15, 2002
	SUPERSEDES DI 55.27	DATED April 21, 2000

11. When a private meter malfunctions, the customer will be notified and the meter will be removed by the City and returned to the customer for repairs. Testing and calibration results shall be given to the City prior to any re-installation.
 12. The register shall be hermetically sealed straight reading and shall be readable from the inlet side. Registration shall be in hundred cubic feet.
 13. The outlet shall have a 2 ½ “National Standards Tested (NST) fire hydrant male coupling.
 14. Private fire hydrant meters shall not be transferable from one contracting company to another (i.e. if a company goes out of business or is bought out by another company).
- 4.4 All fire hydrant meters and appurtenances shall be installed, relocated and removed by the City of San Diego, Water Department. All City owned fire hydrant meters and appurtenances shall be maintained by the City of San Diego, Water Department, Meter Services.
- 4.5 If any fire hydrant meter is used in violation of this Department Instruction, the violation will be reported to the Code Compliance Section for investigation and appropriate action. Any customer using a fire hydrant meter in violation of the requirements set forth above is subject to fines or penalties pursuant to the Municipal Code, Section 67.15 and Section 67.37.
- 4.6 Conditions and Processes for Issuance of a Fire Hydrant Meter**
- Process for Issuance
- a. Fire hydrant meters shall only be used for the following purposes:
 1. Temporary irrigation purposes not to exceed one year.

CITY OF SAN DIEGO CALIFORNIA DEPARTMENT INSTRUCTIONS	NUMBER DI 55.27	DEPARTMENT Water Department
SUBJECT FIRE HYDRANT METER PROGRAM (FORMERLY: CONSTRUCTION METER PROGRAM)	PAGE 5 OF 10	EFFECTIVE DATE October 15, 2002
	SUPERSEDES DI 55.27	DATED April 21, 2000

2. Construction and maintenance related activities (see Tab 2).
 - b. No customer inside or outside the boundaries of the City of San Diego Water Department shall resell any portion of the water delivered through a fire hydrant by the City of San Diego Water Department.
 - c. The City of San Diego allows for the issuance of a temporary fire hydrant meter for a period not to exceed 12 months (365 days). An extension can only be granted in writing from the Water Department Director for up to 90 additional days. A written request for an extension by the consumer must be submitted at least 30 days prior to the 12 month period ending. No extension shall be granted to any customer with a delinquent account with the Water Department. No further extensions shall be granted.
 - d. Any customer requesting the issuance of a fire hydrant meter shall file an application with the Meter Section. The customer must complete a "Fire Hydrant Meter Application" (Tab 1) which includes the name of the company, the party responsible for payment, Social Security number and/or California ID, requested location of the meter (a detailed map signifying an exact location), local contact person, local phone number, a contractor's license (or a business license), description of specific water use, duration of use at the site and full name and address of the person responsible for payment.
 - e. At the time of the application the customer will pay their fees according to the schedule set forth in the Rate Book of Fees and Charges, located in the City Clerk's Office. All fees must be paid by check, money order or cashiers check, made payable to the City Treasurer. Cash will not be accepted.
 - f. No fire hydrant meters shall be furnished or relocated for any customer with a delinquent account with the Water Department.
 - g. After the fees have been paid and an account has been created, the

CITY OF SAN DIEGO CALIFORNIA DEPARTMENT INSTRUCTIONS	NUMBER DI 55.27	DEPARTMENT Water Department
SUBJECT FIRE HYDRANT METER PROGRAM (FORMERLY: CONSTRUCTION METER PROGRAM)	PAGE 6 OF 10	EFFECTIVE DATE October 15, 2002
	SUPERSEDES DI 55.27	DATED April 21, 2000

meter shall be installed within 48 hours (by the second business day). For an additional fee, at overtime rates, meters can be installed within 24 hours (within one business day).

4.7 Relocation of Existing Fire Hydrant Meters

- a. The customer shall call the Fire Hydrant Meter Hotline (herein referred to as “Hotline”), a minimum of 24 hours in advance, to request the relocation of a meter. A fee will be charged to the existing account, which must be current before a work order is generated for the meter’s relocation.
- b. The customer will supply in writing the address where the meter is to be relocated (map page, cross street, etc). The customer must update the original Fire Hydrant Meter Application with any changes as it applies to the new location.
- c. Fire hydrant meters shall be read on a monthly basis. While fire hydrant meters and backflow devices are in service, commodity, base fee and damage charges, if applicable, will be billed to the customer on a monthly basis. If the account becomes delinquent, the meter will be removed.

4.8 Disconnection of Fire Hydrant Meter

- a. After ten (10) months a “Notice of Discontinuation of Service” (Tab 3) will be issued to the site and the address of record to notify the customer of the date of discontinuance of service. An extension can only be granted in writing from the Water Department Director for up to 90 additional days (as stated in Section 4.6C) and a copy of the extension shall be forwarded to the Meter Shop Supervisor. If an extension has not been approved, the meter will be removed after twelve (12) months of use.
- b. Upon completion of the project the customer will notify the Meter Services office via the Hotline to request the removal of the fire hydrant meter and appurtenances. A work order will be generated

CITY OF SAN DIEGO CALIFORNIA DEPARTMENT INSTRUCTIONS	NUMBER DI 55.27	DEPARTMENT Water Department
SUBJECT FIRE HYDRANT METER PROGRAM (FORMERLY: CONSTRUCTION METER PROGRAM)	PAGE 7 OF 10	EFFECTIVE DATE October 15, 2002
	SUPERSEDES DI 55.27	DATED April 21, 2000

for removal of the meter.

- c. Meter Section staff will remove the meter and backflow prevention assembly and return it to the Meter Shop. Once returned to the Meter Shop the meter and backflow will be tested for accuracy and functionality.
- d. Meter Section Staff will contact and notify Customer Services of the final read and any charges resulting from damages to the meter and backflow or its appurtenance. These charges will be added on the customer's final bill and will be sent to the address of record. Any customer who has an outstanding balance will not receive additional meters.
- e. Outstanding balances due may be deducted from deposits and any balances refunded to the customer. Any outstanding balances will be turned over to the City Treasurer for collection. Outstanding balances may also be transferred to any other existing accounts.

5. **EXCEPTIONS**

- 5.1 Any request for exceptions to this policy shall be presented, in writing, to the Customer Support Deputy Director, or his/her designee for consideration.

6. **MOBILE METER**

- 6.1 Mobile meters will be allowed on a case by case basis. All mobile meters will be protected by an approved backflow assembly and the minimum requirement will be a Reduced Pressure Principal Assembly. The two types of Mobile Meters are vehicle mounted and floating meters. Each style of meters has separate guidelines that shall be followed for the customer to retain service and are described below:

- a) **Vehicle Mounted Meters:** Customer applies for and receives a City owned Fire Hydrant Meter from the Meter Shop. The customer mounts the meter on the vehicle and brings it to the Meter Shop for

CITY OF SAN DIEGO CALIFORNIA DEPARTMENT INSTRUCTIONS	NUMBER DI 55.27	DEPARTMENT Water Department
SUBJECT FIRE HYDRANT METER PROGRAM (FORMERLY: CONSTRUCTION METER PROGRAM)	PAGE 8 OF 10	EFFECTIVE DATE October 15, 2002
	SUPERSEDES DI 55.27	DATED April 21, 2000

inspection. After installation is approved by the Meter Shop the vehicle and meter shall be brought to the Meter Shop on a monthly basis for meter reading and on a quarterly basis for testing of the backflow assembly. Meters mounted at the owner's expense shall have the one year contract expiration waived and shall have meter or backflow changed if either fails.

b) **Floating Meters:** Floating Meters are meters that are not mounted to a vehicle. **(Note: All floating meters shall have an approved backflow assembly attached.)** The customer shall submit an application and a letter explaining the need for a floating meter to the Meter Shop. The Fire Hydrant Meter Administrator, after a thorough review of the needs of the customer, (i.e. number of jobsites per day, City contract work, lack of mounting area on work vehicle, etc.), may issue a floating meter. At the time of issue, it will be necessary for the customer to complete and sign the "Floating Fire Hydrant Meter Agreement" which states the following:

- 1) The meter will be brought to the Meter Shop at 2797 Caminito Chollas, San Diego on the third week of each month for the monthly read by Meter Shop personnel.
- 2) Every other month the meter will be read and the backflow will be tested. This date will be determined by the start date of the agreement.

If any of the conditions stated above are not met the Meter Shop has the right to cancel the contract for floating meter use and close the account associated with the meter. The Meter Shop will also exercise the right to refuse the issuance of another floating meter to the company in question.

Any Fire Hydrant Meter using reclaimed water shall not be allowed use again with any potable water supply. The customer shall incur the cost of replacing the meter and backflow device in this instance.

CITY OF SAN DIEGO CALIFORNIA DEPARTMENT INSTRUCTIONS	NUMBER DI 55.27	DEPARTMENT Water Department
SUBJECT FIRE HYDRANT METER PROGRAM (FORMERLY: CONSTRUCTION METER PROGRAM)	PAGE 9 OF 10	EFFECTIVE DATE October 15, 2002
	SUPERSEDES DI 55.27	DATED April 21, 2000

7. **FEE AND DEPOSIT SCHEDULES**

7.1 **Fees and Deposit Schedules:** The fees and deposits, as listed in the Rate Book of Fees and Charges, on file with the Office of the City Clerk, are based on actual reimbursement of costs of services performed, equipment and materials. These deposits and fees will be amended, as needed, based on actual costs. Deposits, will be refunded at the end of the use of the fire hydrant meter, upon return of equipment in good working condition and all outstanding balances on account are paid. Deposits can also be used to cover outstanding balances.

All fees for equipment, installation, testing, relocation and other costs related to this program are subject to change without prior notification. The Mayor and Council will be notified of any future changes.

8. **UNAUTHORIZED USE OF WATER FROM A HYDRANT**

8.1 Use of water from any fire hydrant without a properly issued and installed fire hydrant meter is theft of City property. Customers who use water for unauthorized purposes or without a City of San Diego issued meter will be prosecuted.

8.2 If any unauthorized connection, disconnection or relocation of a fire hydrant meter, or other connection device is made by anyone other than authorized Water Department personnel, the person making the connection will be prosecuted for a violation of San Diego Municipal Code, Section 67.15. In the case of a second offense, the customer's fire hydrant meter shall be confiscated and/or the deposit will be forfeited.

8.3 Unauthorized water use shall be billed to the responsible party. Water use charges shall be based on meter readings, or estimates when meter readings are not available.

8.4 In case of unauthorized water use, the customer shall be billed for all applicable charges as if proper authorization for the water use had been obtained, including but not limited to bi-monthly service charges, installation charges and removal charges.

CITY OF SAN DIEGO CALIFORNIA DEPARTMENT INSTRUCTIONS	NUMBER DI 55.27	DEPARTMENT Water Department
SUBJECT FIRE HYDRANT METER PROGRAM (FORMERLY: CONSTRUCTION METER PROGRAM)	PAGE 10 OF 10	EFFECTIVE DATE October 15, 2002
	SUPERSEDES DI 55.27	DATED April 21, 2000

- 8.5 If damage occurs to Water Department property (i.e. fire hydrant meter, backflow, various appurtenances), the cost of repairs or replacements will be charged to the customer of record (applicant).

Water Department Director

- Tabs: 1. Fire Hydrant Meter Application
2. Construction & Maintenance Related Activities With No Return To Sewer
3. Notice of Discontinuation of Service

APPENDIX

Administering Division: Customer Support Division

Subject Index: Construction Meters
Fire Hydrant
Fire Hydrant Meter Program
Meters, Floating or Vehicle Mounted
Mobile Meter
Program, Fire Hydrant Meter

Distribution: DI Manual Holders



Application for Fire Hydrant Meter (EXHIBIT A)

(For Office Use Only)

NS REQ	FAC#
DATE	BY

METER SHOP (619) 527-7449

Meter Information

Application Date	Requested Install Date:
------------------	-------------------------

Fire Hydrant Location: (Attach Detailed Map//Thomas Bros. Map Location or Construction drawing.) <u>Zip:</u>	T.B.	G.B. (CITY USE)
Specific Use of Water:		
Any Return to Sewer or Storm Drain, if so, explain:		
Estimated Duration of Meter Use: <input type="text"/>	<input type="checkbox"/>	Check Box if Reclaimed Water

Company Information

Company Name:			
Mailing Address:			
City:	State:	Zip:	Phone: ()
*Business license#		*Contractor license#	
A Copy of the Contractor's license OR Business License is required at the time of meter issuance.			
Name and Title of Billing Agent: <small>(PERSON IN ACCOUNTS PAYABLE)</small>			Phone: ()
Site Contact Name and Title:			Phone: ()
Responsible Party Name:			Title:
Cal ID#			Phone: ()
Signature:		Date:	
<small>Guarantees Payment of all Charges Resulting from the use of this Meter. Insures that employees of this Organization understand the proper use of Fire Hydrant Meter</small>			

Fire Hydrant Meter Removal Request	Requested Removal Date:
Provide Current Meter Location if Different from Above:	
Signature:	Title: Date:
Phone: ()	Pager: ()

<input type="checkbox"/> City Meter	<input type="checkbox"/> Private Meter
Contract Acct #:	Deposit Amount: \$ 936.00 Fees Amount: \$ 62.00
Meter Serial #	Meter Size: 05 Meter Make and Style: 6-7
Backflow #	Backflow Size: Backflow Make and Style:
Name:	Signature: Date:

WATER USES WITHOUT ANTICIPATED CHARGES FOR RETURN TO SEWER

Auto Detailing
Backfilling
Combination Cleaners (Vactors)
Compaction
Concrete Cutters
Construction Trailers
Cross Connection Testing
Dust Control
Flushing Water Mains
Hydro Blasting
Hydro Seeing
Irrigation (for establishing irrigation only; not continuing irrigation)
Mixing Concrete
Mobile Car Washing
Special Events
Street Sweeping
Water Tanks
Water Trucks
Window Washing

Note:

1. If there is any return to sewer or storm drain, then sewer and/or storm drain fees will be charges.

Date

Name of Responsible Party
Company Name and Address
Account Number: _____

Subject: Discontinuation of Fire Hydrant Meter Service

Dear Water Department Customer:

The authorization for use of Fire Hydrant Meter # _____, located at (*Meter Location Address*) ends in 60 days and will be removed on or after (*Date Authorization Expires*). Extension requests for an additional 90 days must be submitted in writing for consideration 30 days prior to the discontinuation date. If you require an extension, please contact the Water Department, or mail your request for an extension to:

City of San Diego
Water Department
Attention: Meter Services
2797 Caminito Chollas
San Diego, CA 92105-5097

Should you have any questions regarding this matter, please call the Fire Hydrant Hotline at (619) _____ - _____.

Sincerely,

Water Department

APPENDIX C

MATERIALS TYPICALLY ACCEPTED BY CERTIFICATE OF COMPLIANCE

MATERIALS TYPICALLY ACCEPTED BY CERTIFICATE OF COMPLIANCE

1. Soil amendment
2. Fiber mulch
3. PVC or PE pipe up to 16 inch diameter
4. Stabilizing emulsion
5. Lime
6. Preformed elastomeric joint seal
7. Plain and fabric reinforced elastomeric bearing pads
8. Steel reinforced elastomeric bearing pads
9. Waterstops (Special Condition)
10. Epoxy coated bar reinforcement
11. Plain and reinforcing steel
12. Structural steel
13. Structural timber and lumber
14. Treated timber and lumber
15. Lumber and timber
16. Aluminum pipe and aluminum pipe arch
17. Corrugated steel pipe and corrugated steel pipe arch
18. Structural metal plate pipe arches and pipe arches
19. Perforated steel pipe
20. Aluminum underdrain pipe
21. Aluminum or steel entrance tapers, pipe downdrains, reducers, coupling bands and slip joints
22. Metal target plates
23. Paint (traffic striping)
24. Conductors
25. Painting of electrical equipment
26. Electrical components
27. Engineering fabric
28. Portland Cement
29. PCC admixtures
30. Minor concrete, asphalt
31. Asphalt (oil)
32. Liquid asphalt emulsion
33. Epoxy

APPENDIX D

SAMPLE CITY INVOICE WITH CASH FLOW FORECAST

WBS #:	B18108
Date Submitted:	10/10/2018
NTP Date:	3/23/2018
Final Statement of WD Date:	5/23/2020
Contract #:	K-XX-XXXX-XXX-X
Contract Amount:	\$5,617,000

Construction Cash Flow Forecast
 "Sewer and Water Group Job 965 (W)"

Year	January	February	March	April	May	June	July	August	September	October	November	December
2018				15,000	25,000	52,000	52,000	100,000	10,000	100,000	100,000	100,000
2019	10,000	10,000	85,000	58,000	100,000	100,000	100,000	100,000	100,000	100,000	1,000,000	1,000,000
2020	100,000	100,000	100,000	1,000,000	1,000,000							
2021												
2022												
2023												
2024												
2025												

SAMPLE REFERENCE

APPENDIX E
LOCATION MAP

Wangenheim Neighborhood Park Joint Use Facility

SENIOR ENGINEER
Kevin Oliver
(619) 533-5139

PROJECT MANAGER
Yovanna Lewis
(619) 5335130

PROJECT ENGINEER

FOR QUESTIONS ABOUT THIS PROJECT
Call: 619-533-4207
Email: engineering@sandiego.gov

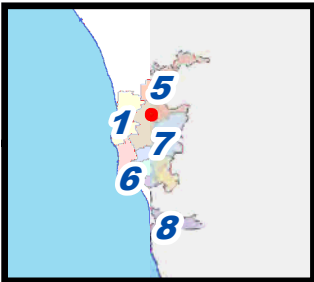

Project Location

Wangenheim Neighborhood Park Joint Use Facility

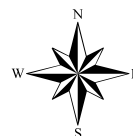

THIS MAP/DATA IS PROVIDED WITHOUT WARRANTY OF ANY KIND, EITHER EXPRESS OR IMPLIED, INCLUDING, BUT NOT LIMITED TO, THE IMPLIED WARRANTIES OR MERCHANTABILITY AND FITNESS FOR A PARTICULAR PURPOSE. Note: This product may contain information reproduced with permission granted by RAND MCNALLY & COMPANY® to SanGIS. This map is copyrighted by RAND MCNALLY & COMPANY®. It is unlawful to copy or reproduce all or any part thereof, whether for personal use or resale, without the prior, written permission of RAND MCNALLY & COMPANY.

APPENDIX F
ADJACENT PROJECT MAP

C:\Users\m71\OneDrive\Documents\2019\08\23\104\104_001\104_001_001.dwg - 10/23/2019 10:00:00 AM - Copyright © 2019 ZAGROONIK + THOMAS ARCHITECTS, L.L.P.

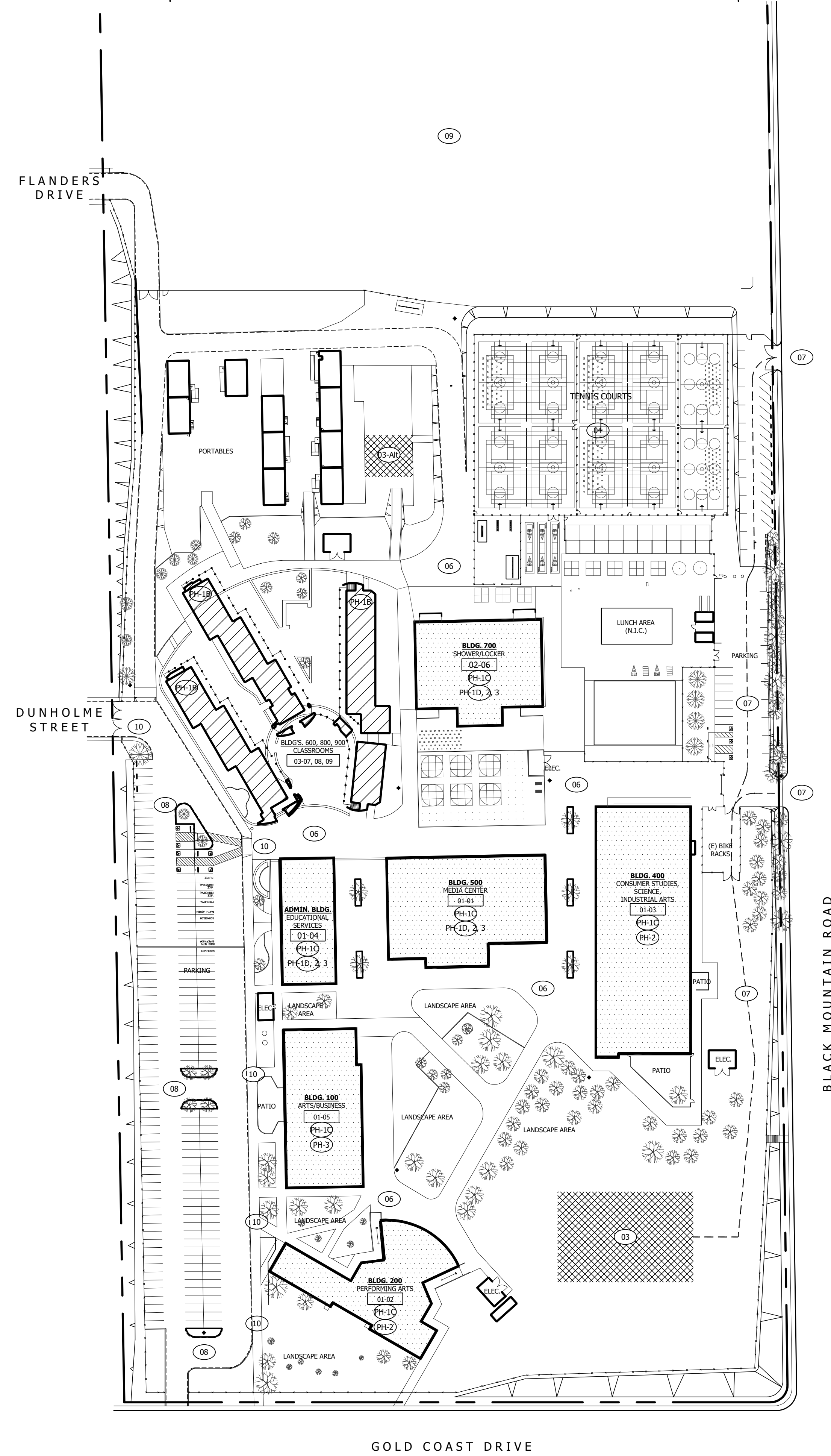

1 CONSTRUCTION AND PHASING PLAN
1"=80'-0"

NOTES
1. See Sheet G-0.2 for Notes, Legends, Abbreviations, Etc. not provided on this page.

REFERENCE KEYNOTES

SITE/PHASING -

01	SCOPE OF WORK: RE-ROOFING/ HVAC REPLACEMENT, EXTERIOR LIGHTING CONTROLS, IDF/MDF ROOM COOLING: 100, 200, 400, 500, 700 AND ADMINISTRATION BUILDINGS. REFER TO SHEETS A1-1.1 THROUGH A8-1.2 FOR DEMOLITION AND CONSTRUCTION PLANS. SEE ADDITIONAL PHASING NOTES ON EACH BUILDING.
02	SCOPE OF WORK: IDF/MDF ROOM COOLING SCOPE ONLY: BUILDING 600, 800, & 900. REFER TO SHEET A-9.1 FOR IDF/MDF ROOM LOCATIONS AND REFERENCES TO ENLARGED PLANS. SEE ADDITIONAL PHASING NOTES ON EACH BUILDING.
03	CONTRACTOR LAY-DOWN AREA. AVAILABLE FOR CONTRACTOR USE FOR THE DURATION OF THE PROJECT. CONTRACTOR TO CLEAR WEEDS AND BRUSH WITHIN THE STAGING AREA AND ALONG ALL VEHICULAR AND PEDESTRIAN ACCESS ROUTES PRIOR TO MOBILIZATION AND AS NEEDED DURING THE COURSE OF CONSTRUCTION. CONTRACTOR TO PROVIDE SECURITY FENCING AT PERIMETER. MAINTAIN 20' CLEAR FROM ALL BUILDINGS. KEEP FIRE LANES CLEAR AT ALL TIMES. CONTRACTOR TO REMOVE ALL TRAILERS, TEMPORARY FENCING, MATERIALS, EQUIPMENT, TRASH, ETC. AT PROJECT COMPLETION. RETURN AREA TO PREVIOUS EXISTING CONDITION.
03-ALT.	ALTERNATE OR SECONDARY CONTRACTOR LAY DOWN AREA. SEE NOTE 03.
04	AREA OF SAFE DISPERSAL. AREA TO REMAIN CLEAR DURING SPRING 2021* AND FALL 2021*.
06	CONTRACTOR TO PROTECT EXISTING CONCRETE SIDEWALKS FROM TIRE MARKINGS CAUSED BY VEHICLES AND EQUIPMENT FOR THE DURATION OF THE PROJECT.
07	CONTRACTOR VEHICULAR ACCESS.
08	CONCURRENT CONSTRUCTION SOLAR PV PROJECT. NO ACCESS.
09	CONCURRENT CONSTRUCTION: JOINT USE FEILD. NO ACCESS.
10	POTENTIAL CONCURRENT CONSTRUCTION: SECURITY FENCING.
PH-1B	WORK SHOULD BE PERFORMED DURING PHASE 1B. REFER TO SPECS FOR ADDITIONAL INFORMATION ON PHASING.
PH-1C	ALL WORK TO EXTERIOR LIGHTING CONTROLS MUST BE PERFORMED DURING PHASE 1C. REFER TO SPECS FOR ADDITIONAL INFORMATION ON PHASING.
PH-1D, 2, 3	ALL WORK ON THE ROOF MAY BE PERFORMED DURING PHASES 1, 2, AND/OR 3. REFER TO SPECS FOR ADDITIONAL INFORMATION ON PHASING.
PH-2	ALL WORK ON THE ROOF MUST BE PERFORMED DURING PHASE 2. REFER TO SPECS FOR ADDITIONAL INFORMATION ON PHASING.
PH-3	ALL WORK ON THE ROOF MUST BE PERFORMED DURING PHASE 3. REFER TO SPECS FOR ADDITIONAL INFORMATION ON PHASING.

* Refer to spec Section 01 10 00 Summary for additional information including School Schedule and definitions of "Spring", "Summer", and "Fall".

"DRAFT"

LEGEND

	01
	02
	03
	(E) Fence

CONSTRUCTION AND PHASING PLAN

FACILITIES MANAGEMENT
WANGENHEIM MIDDLE SCHOOL
RE-ROOFING & HVAC PROJECT
9230 GOLD COAST DRIVE, SAN DIEGO, CA 92126

PROJECT NO. DSA 04-118591
R.S. ZTA 1914 A.P.
FILE NAME
DATE 23 Aug, 2019 DRAWN -
REVISIONS CHECKED -
SHEET NO.
A-0.2
OF SHEETS

PREPARED FOR THE
BOARD OF EDUCATION
SAN DIEGO UNIFIED SCHOOL DISTRICT
SAN DIEGO, CALIFORNIA
PREPARED BY:
ZAGROONIK + THOMAS ARCHITECTS, L.L.P.

LICENSED ARCHITECT
SCOTT THOMAS
SANTA 87
REN. 6-30-21
ARCHITECT
STATE OF CALIFORNIA

SAN DIEGO UNIFIED SCHOOLS DISTRICT

District QA/QC/DSA Submittal

SHEETS ARE 24" X 36" AT FULL SIZE
© ZAGROONIK + THOMAS 2019 586 | Page

APPENDIX G
SAMPLE OF PUBLIC NOTICE



CONSTRUCTION NOTICE

PROJECT TITLE

Work on your street will begin within one week to replace the existing water mains servicing your community.

The work will consist of:

- Saw-cutting and trench work on Ingulf Street from Morena Boulevard to Galveston Street to install new water mains, water laterals and fire hydrants.
• Streets where trenching takes place will be resurfaced and curb ramps will be upgraded to facilitate access for persons with disabilities where required.
• This work is anticipated to be complete in your community by December 2016.

How your neighborhood may be impacted:

- Water service to some properties during construction will be provided by a two-inch highline pipe that will run along the curb. To report a highline leak call 619-515-3525.
• Temporary water service disruptions are planned. If planned disruptions impact your property, you will receive advance notice.
• Parking restrictions will exist because of the presence of construction equipment and materials.
• "No Parking" signs will be displayed 72 hours in advance of the work.
• Cars parked in violation of signs will be TOWED.

Hours and Days of Operation:

Monday through Friday X:XX AM to X:XX PM.

City of San Diego Contractor:

Company Name, XXX-XXX-XXXX



CONSTRUCTION NOTICE

PROJECT TITLE

Work on your street will begin within one week to replace the existing water mains servicing your community.

The work will consist of:

- Saw-cutting and trench work on Ingulf Street from Morena Boulevard to Galveston Street to install new water mains, water laterals and fire hydrants.
• Streets where trenching takes place will be resurfaced and curb ramps will be upgraded to facilitate access for persons with disabilities where required.
• This work is anticipated to be complete in your community by December 2016.

How your neighborhood may be impacted:

- Water service to some properties during construction will be provided by a two-inch highline pipe that will run along the curb. To report a highline leak call 619-515-3525.
• Temporary water service disruptions are planned. If planned disruptions impact your property, you will receive advance notice.
• Parking restrictions will exist because of the presence of construction equipment and materials.
• "No Parking" signs will be displayed 72 hours in advance of the work.
• Cars parked in violation of signs will be TOWED.

Hours and Days of Operation:

Monday through Friday X:XX AM to X:XX PM.

City of San Diego Contractor:

Company Name, XXX-XXX-XXXX

APPENDIX H

ADVANCED METERING INFRASTRUCTURE (AMI) DEVICE PROTECTION

Protecting AMI Devices in Meter Boxes and on Street Lights

The Public Utilities Department (PUD) has begun the installation of the Advanced Metering Infrastructure (AMI) technology as a new tool to enhance water meter reading accuracy and efficiency, customer service and billing, and to be used by individual accounts to better manage the efficient use of water. **All AMI devices shall be protected per Section 402-2, "Protection", of the 2018 Whitebook.**

AMI technology allows water meters to be read electronically rather than through direct visual inspection by PUD field staff. This will assist PUD staff and customers in managing unusual consumption patterns which could indicate leaks or meter tampering on a customer's property.

Three of the main components of an AMI system are the:

- A. Endpoints, see Photo 1:

Photo 1



B. AMI Antenna attached to Endpoint (antenna not always required), see Photo 2:



Network Devices, see Photo 3:

Photo 3



AMI endpoints transmit meter information to the AMI system and will soon be on the vast majority of meters in San Diego. These AMI devices provide interval consumption data to the PUD's Customer Support Division. If these devices are damaged or communication is interrupted, this Division will be alerted of the situation. The endpoints are installed in water meter boxes, coffins, and vaults adjacent to the meter. A separate flat round antenna may also be installed through the meter box lid. This antenna is connected to the endpoint via cable. The following proper installation shall be implemented when removing the lid to avoid damaging the antenna, cable, and/or endpoint. Photo 4 below demonstrates a diagram of the connection:

Photo 4



The AMI device ERT/Endpoint/Transmitter shall be positioned and installed as discussed in this Appendix. If the ERT/Endpoint/Transmitter is disturbed, it shall be re-installed and returned to its original installation with the end points pointed upwards as shown below in Photo 5.

The PUD's code compliance staff will issue citations and invoices to you for any damaged AMI devices that are not re-installed as discussed in the Contract Document

Photo 5 below shows a typical installation of an AMI endpoint on a water meter.

Photo 5

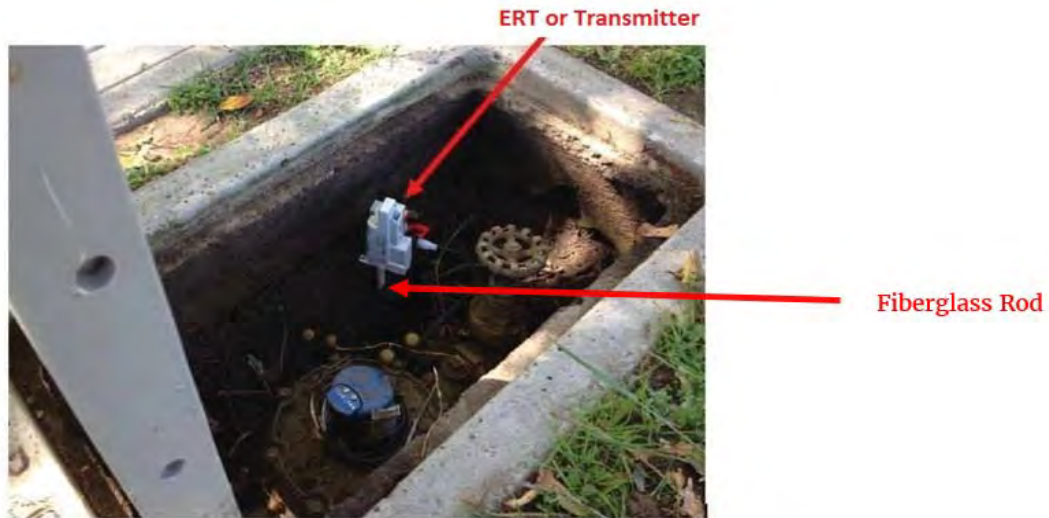

Photo 6 below is an example of disturbance that shall be avoided:

Photo 6



You are responsible when working in and around meter boxes. If you encounter these endpoints, use proper care and do not disconnect them from the registers on top of the water meter. If the lid has an antenna drilled through, do not change or tamper with the lid and inform the Resident Engineer immediately about the location of that lid. Refer to Photo 7 below:

Photo 7



Another component of the AMI system are the Network Devices. The Network Devices are strategically placed units (mainly on street light poles) that collect interval meter reading data from multiple meters for transmission to the Department Control Computer. **If you come across any of these devices on street lights that will be removed or replaced (refer to Photos 8 and 9 below), notify AMI Project Manager Arwa Sayed at (619) 362-0121 immediately.**

Photo 8 shows an installed network device on a street light. On the back of each Network Device is a sticker with contact information. See Photo 9. **Call PUD Water Emergency Repairs at 619-515-3525 if your work will impact these street lights.** These are assets that belong to the City of San Diego and you shall be responsible for any costs of disruption of this network.

Photo 8



Network Device

Photo 9



If you encounter any bad installations, disconnected/broken/buried endpoints, or inadvertently damage any AMI devices or cables, notify the Resident Engineer immediately. The Resident Engineer will then immediately contact the AMI Project Manager, Arwa Sayed, at (619) 362-0121.

APPENDIX I

MUNITION OF EXPLOSIVE CONCERN SPECIFICATIONS

Munition of Explosive Concern - Unexploded Ordnance Support for Wangenheim Neighborhood Joint Use Facility Project

This document provides background information regarding the former Linda Vista Valley Auxiliary Bomb Site and bid specifications for providing Munition of Explosive Concern (MEC) and Unexploded Ordnance construction support during construction activities for the Wangenheim Neighborhood Joint Use Facility.

BACKGROUND

The Department of Defense (DoD) is responsible for environmental restoration of properties that were formerly owned by, leased to, or otherwise possessed by the United States and under the jurisdiction of the Secretary of Defense prior to October 1986 (i.e. FUDS properties). The United States Army Corps of Engineers (USACE) manages and directs the FUDS program's administration. USACE Los Angeles District (CESPL) is responsible for the Linda Vista Valley Auxiliary Field Formally Used Defense Site (Linda Vista FUDS).

The Linda Vista FUDS is located approximately one mile north of Marine Corps Air Station Miramar (formally Naval Air Station [NAS] Miramar) and west of Interstate 15. It consists of approximately 215 acres located in the community of Mira Mesa within the City and County of San Diego. The City of San Diego, San Diego Unified School District (SDUSD), San Diego Community College District (SDCCD), and private property owners own parcels located within the Linda Vista FUDS site. The Linda Vista FUDS site also encompasses two mobile home parks (The Woods Mobilehome Park and Village Green Mobilehome Park) developed in the late-1960s.

Acquisition of the Linda Vista Valley Auxiliary Field began in 1931 when the Chief of the Bureau of Aeronautics leased 640 acres north of Camp Kearney. A portion of the acreage was to be used as an Auxiliary Flying Field to support NAS San Diego. The Navy acquired about 170 (of the original 640 acres) in 1941 for continued use as an outlying field. In 1942, the Navy acquired an additional 43 acres (also of the original 640 acres) for use as a practice bombing target. At one point in time the property was used for the storage of surplus buildings. The Navy disposed of the original 170 acres in August 1961 by quit claim deed to San Diego School District. The remaining 43.11 acres were auctioned off in 1962 to a private developer. Military related improvements reportedly consisted of an asphalt surface of approximately 65 acres, some fencing, and the practice bomb target.

The CESPL began investigating the Linda Vista Valley Auxiliary Field site in 1997, with the 1997 Inventory Project Report (INPR) which established the Linda Vista Valley Auxiliary site as a FUDS with assigned Project Number J09CA723601. The INPR recommended an investigation to evaluate the presence of MEC. In 2001 an Archives Search Report (ASR) was completed by the U.S. Army Corps of Engineers, Rock Island District (CEMVR) and in 2004 an ASR Supplement was completed which recalculated and established the current acreage of the Linda Vista Valley Auxiliary Field site to be 72 acres.

In March of 2009 a Site Inspection Report was published documenting the MEC and munition constituents (MC) field investigation results, data analysis results, and recommendation. The

Department of Toxic Substances Control (DTSC) reviewed the report and recommendation to proceed to the Remedial Investigation and Feasibility Study (RI/FS) phase for Practice Bomb Target 1 (PBT 1) and AOI Target 2. Since this letter was issued, no documentation has been located to demonstrate that the recommended sampling or site closure activities have been conducted for the Linda Vista FUDS. Although no munitions and explosives of concern (MEC) or munitions debris (MD) were observed during the SI field effort for PBT 1 and AOI Target 2, munitions were reported to be used at the FUDS. The length of time the munitions were used is not documented; however historical records indicate that military munitions used at the FUDS included 3 and 4-pound miniature practice bombs (specifically, AN-Mk 5, AN-Mk 23, AN-Mk 43 practice bombs).

The San Diego Fire Department's Bomb Squad reported that ten AN-Mk 5 practice bombs were discovered during modernization projects recently completed at Miramar Community College which is located on the opposite side of Black Mountain Road from the proposed park project. Because of the potential of encountering the referenced ordnance, MEX/UXO construction support is warranted at the Site.

SCOPE OF WORK

Task 1 – Pre-Construction MEC/UXO Awareness Meeting

The MEC/UXO Contractor will conduct a MEC/UXO awareness session with contract personnel that will be conducting grading and/or ground-disturbing activities. The Munition Response Plan for the Wangenheim Joint Use Facility will serve as the basis for the awareness training. Topics will focus on Recognize, Retreat, and Report Protocol as well as an Avoidance Protocol. The awareness meeting will be conducted two days before field activities start. For the purpose of this scope of work, assume that the duration of the meeting will be no more than 90 minutes. The MEC/UXO Contractor is expected to provide all necessary materials for the awareness meeting. A log of attendees will be maintained by the MEC/UXO Contractor to verify that all site personnel attended the awareness meeting. Relevant discussion topics during the training include the following bullets at a minimum.

- Identify the Point of Contacts (POC) including but not limited to:
 - USACE contact for SDUSD inquiries and response action to discovered Munitions Explosive Concern (MEC).
 - City of San Diego representatives.
 - SDUSD representative to handle any faculty/parent/contractor inquiries and lead response action to discovered MEC.
 - School Principals or other school representatives.
- Review Implementation Procedures
 - Awareness Briefing and Notification – MEC/UXO contractor may request that the San Diego Fire Department Bomb Squad participate in a UXO Awareness Briefing informing the construction personnel of the potential ordnance hazards and the precautions to be taken.
 - An action plan will be developed to describe the response in case of MEC discovery. The action plan will specify contacts at Marine Corps Air Station (MCAS)

- Miramar and the San Diego Fire Department (SDFD).

- Worker MEC briefing materials would include the following:
 - Contractor Ordnance Info Sheet
 - Contractor Fact Sheet

Task 2 – Detector-Aided Visual Survey and Reporting

Construction activities associated with the joint-use facility may include site grading and utility trenching activities. The site may be graded to a depth of approximately 18 to 24 inches below ground surface. Prior to the start of construction activities, the MEC/UXO contractor will perform a UXO detector-aided visual survey of select areas of the project area where ground-disturbing and/or excavation activities are planned. These areas include:

- 11,000 sq ft in the Playground Area
- 13,500 sq ft in the new Snack Bar Area/Comfort Station
- 60,500 sq ft in the Southwest Parking Lot

The field team will consist of a Level III UXO technician with an assistant. Assume that the project area will be protected by a security fence to prevent visitors to the park area from entering the project area.

Any anomalies detected by the UXO Support team that are suspected to be UXO, MEC, or MD will be marked at the surface with plastic pin flags and plotted with a Trimble ProXRT global positioning system (GPS), providing sub-meter real time accuracy. If suspect MEC/UXO/MD is encountered, the UXO personnel will attempt to identify the item and to gather additional information such as the munitions type. The item will be marked with a yellow survey marker flag and given a unique ID number. All available information about the item will be recorded in the logbook/Daily MEC Accountability Log, including the suspect MEC location, description, and ID number. Additionally, a digital photograph will be taken of each item.

The MEC contractor will not be responsible for excavating or removing suspected MEC/UXO/MD. Instead, the MEC contractor will notify the San Diego Fire Department Bomb Squad of the suspected items.

Any scrap metal suspected to be MEC or MDEH that is encountered will be certified free of explosive material by the San Diego Fire Department or qualified personnel from the Army Corps of Engineers or Department of Defense prior to transfer. Handling, transport, and storage of MDAS will be conducted by ACOE or DOD representatives in accordance with applicable rules and procedures.

Following the completion of UXO Support detector-aided visual survey, the MEC/UXO Contractor will prepare an After Action Report to document that the munitions response is complete at the school site. The After Action Report will provide a summary of UXO/MEC/MD items found and/or recovered, include mapped locations where they were encountered, and actions taken to neutralize material encountered during screening activities.

Scope of Work Clarifications

- The White's Spectrum XLT all metal detector and/or equivalent will be the survey instruments employed during the intrusive anomaly investigation.
- A detailed log will be maintained documenting the location, depth, description, and disposition of MPPEH items encountered. All MPPEH items investigated will be evaluated by a qualified UXO technician and designated as either MDAS or material documented as an explosive hazard (MDEH).
- San Diego Fire Department personnel will be responsible for treatment of MEC/MDEH on site. If the UXO team or Fire Department is unable to identify a MEC item or the item is beyond the capabilities of the UXO team (for example larger than the munition with greatest fragment distance [MGFD] or chemical filled), The Contractor or Fire Department personnel will notify the nearest military Explosive Ordnance Disposal unit.
- Contractor will take digital photographs of MPPEH found during the investigation, which will be attached to MPPEH locations displayed in ArcGIS within the After Action Report.

Task 3 – MEC/UXO Construction Support

During all site grading and/or intrusive ground disturbing activities, the MEC/UXO Construction Support contractor will provide qualified UXO personnel or a UXO Support team to serve as escorts to the construction contractor during intrusive activities to protect the construction contractor for possible hazards associated with MEC/UXO/MD. MEC/UXO personnel will use visual protocol and specialized metal detecting equipment to inspect the grading/intrusive work area for possible MEC/UXO/MD. Metal detecting equipment may include a Schonstedt GA-53CX or equivalent.

The MEC/UXO technician will conduct daily safety briefings with the contract personnel to review safety procedures and identify work areas. A daily log will be maintained to track daily activities, site personnel, observations, and findings.

If suspect MEC/UXO/MD is encountered during construction activities, the UXO personnel will mark the location of the MEC/UXO/MD item and move all construction personnel to a safe staging area. The MEC/UXO Contractor will be responsible for contacting the San Diego Fire Department Bomb Squad to identify, secure, and remove the item discovered. If the item is determined to be MD or scrap metal, the item will be collected and stored for subsequent offsite disposal.

Task 4 – Field Summary Report

Within 10 working days of completing Task 3 Construction Support activities, the contractor will provide a Field Summary Report describing the field activities. The Field Summary Report will include figures and tables depicting the site activities and observations. At a minimum, the Field Summary Report will include:

- Identification of the MEC/UXO Construction Support personnel on site.
- Description of the activities conducted, and work area observed.

- A summary of daily activities and observations. Daily log sheets will be provided as an appendix to the summary report.
- Description(s) of MEC/UXO encountered including maps and photographs of MEC/UXO/MD encountered and documenting the location of the item(s) encountered.
- A description of response actions.
- Daily photographs provided as an appendix

One electronic copy of the Field Summary Report will be provided in PDF format.

QUALIFICATIONS

MEC Inspection team will be led by a UXO Technician Level III qualified personnel.

MEASUREMENT AND PAYMENT

The Lump Sum Bid item for “**Munition of Explosive Concern**” shall include payment for all Work specified in these specifications and no additional payment shall be made.

APPENDIX J

SWPPP CONSTRUCTION BMP MAINTENANCE LOG

SWPPP Construction BMP Maintenance Log

Examples of construction BMP maintenance activities include but are not limited to tasks listed below. The contractor is ultimately responsible for compliance with the Storm Water Standards Manual and/or the Construction General Permit, and for ensuring all BMPs function per manufacturer's specifications. Use the attached log to schedule and document maintenance activities. The log shall be kept with the project SWPPP document at all times.

Construction BMP Maintenance Activities

- Maintain stabilized construction entrances/exits
- Redress gravel/rock to full coverage and remove any sediment accumulation
- Remove and replace geotextile/compost blanket/plastic with holes or tears
- Redress and restabilize erosion or rilling greater than 1-inch deep
- Reapply hydraulic stabilization products to full coverage
- Remove and replace silt fence/fiber roll/gravel bags/etc. with holes or tears
- Reinstall or replace silt fence/fiber roll/etc. with sags
- Remove sediment accumulation from perimeter controls
- Remove sediment accumulation from storm drain inlet protection and check dams
- Remove sediment accumulation from energy dissipators
- Repair or remove any vehicle/equipment that leaks
- Remove any accumulation in drip pans or containment
- Empty concrete washouts when they reach 75% capacity
- Empty waste disposal containers when they reach 95% capacity

Construction BMP Maintenance Log

Project Title:

WBS/IO No:

WDID:

Scheduled Date/Time	Completion Date/Time	Location	Maintenance Tasks Performed	Logged By

ATTACHMENT F
RESERVED

ATTACHMENT G
CONTRACT AGREEMENT

CONTRACT AGREEMENT

CONSTRUCTION CONTRACT

This contract is made and entered into between THE CITY OF SAN DIEGO, a municipal corporation, herein called "City", and Tri-Group Construction & Development, Inc., herein called "Contractor" for construction of **Wangenheim Neighborhood Park Joint Use Facility**; Bid No. **K-21-1986-DBB-3**; in the total amount Six Million Eight Hundred Thirty Four Thousand Dollars and Zero Cents (\$6,834,000.00), which is comprised of the Base Bid.

IN CONSIDERATION of the payments to be made hereunder and the mutual undertakings of the parties hereto, City and Contractor agree as follows:

1. The following are incorporated into this contract as though fully set forth herein:
 - (a) The attached Faithful Performance and Payment Bonds.
 - (b) The attached Proposal included in the Bid documents by the Contractor.
 - (c) Reference Standards listed in the Instruction to Bidders and the Supplementary Special Provisions (SSP).
 - (d) That certain documents entitled **Wangenheim Neighborhood Park Joint Use Facility**, on file in the office of the Engineering & Capital Projects Department as Document No. **S-15007** as well as all matters referenced therein.
2. The Contractor shall perform and be bound by all the terms and conditions of this contract and in strict conformity therewith shall perform and complete in a good and workmanlike **Wangenheim Neighborhood Park Joint Use Facility**, Bid Number **K-21-1986-DBB-3**, San Diego, California.
3. For such performances, the City shall pay to Contractor the amounts set forth at the times and in the manner and with such additions or deductions as are provided for in this contract, and the Contractor shall accept such payment in full satisfaction of all claims incident to such performances
4. No claim or suit whatsoever shall be made or brought by Contractor against any officer, agent, or employee of the City for or on account of anything done or omitted to be done in connection with this contract, nor shall any such officer, agent, or employee be liable hereunder.
5. This contract is effective as of the date that the Mayor or designee signs the agreement and is approved by the City Attorney in accordance with San Diego Charter Section 40.

CONTRACT AGREEMENT (continued)

IN WITNESS WHEREOF, this Agreement is signed by the City of San Diego, acting by and through its Mayor or designee, pursuant to Municipal Code §22.3102 authorizing such execution.

THE CITY OF SAN DIEGO

APPROVED AS TO FORM

By 

Mara W. Elliott, City Attorney

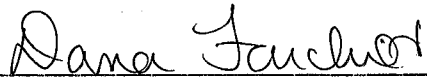
By 

Print Name: Cindy Crocker
Acting Deputy Director
Purchasing & Contracting Department

Print Name: Dana Fairchild
Deputy City Attorney

Date: 11/15/2021

Date: 11/16/2021

CONTRACTOR

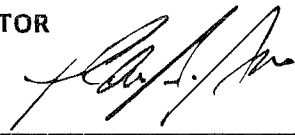
By 

Print Name: HANI ASSI

Title: SECRETARY OF CORPORATION

Date: 04-30-2021

City of San Diego License No.: B2003004679

State Contractor's License No.: 792159

DEPARTMENT OF INDUSTRIAL RELATIONS (DIR) REGISTRATION NUMBER: 1000004777

CERTIFICATIONS AND FORMS

The Bidder, by submitting its electronic bid, agrees to and certifies under penalty of perjury under the laws of the State of California, that the certifications, forms and affidavits submitted as part of this bid are true and correct.

BIDDER'S GENERAL INFORMATION

To the City of San Diego:

Pursuant to "Notice Inviting Bids", specifications, and requirements on file with the City Clerk, and subject to all provisions of the Charter and Ordinances of the City of San Diego and applicable laws and regulations of the United States and the State of California, the undersigned hereby proposes to furnish to the City of San Diego, complete at the prices stated herein, the items or services hereinafter mentioned. The undersigned further warrants that this bid is not made in the interest of, or on behalf of, any undisclosed person, partnership, company, association, organization, or corporation; that the bid is genuine and not collusive or sham; that the bidder has not directly or indirectly induced or solicited any other bidder to put in a false or sham bid, and has not directly or indirectly colluded, conspired, connived, or agreed with any bidder or anyone else to put in a sham bid, or that anyone shall refrain from bidding; that the bidder has not in any manner, directly or indirectly, sought by agreement, communication, or conference with anyone to fix the bid price of the bidder or any other bidder, or to fix any overhead, profit, or cost element of the bid price, or of that of any other bidder, or to secure any advantage against the public body awarding the contract of anyone interested in the proposed contract; that all statements contained in the bid are true; and, further, that the bidder has not, directly or indirectly, submitted his or her bid price or any breakdown thereof, or the contents thereof, or divulged information or data relative thereto, or paid, and will not pay, any fee to any corporation, partnership, company, association, organization, bid depository, or to any member or agent thereof to effectuate a collusive or sham bid.

The undersigned bidder(s) further warrants that bidder(s) has thoroughly examined and understands the entire Contract Documents (plans and specifications) and the Bidding Documents therefore, and that by submitting said Bidding Documents as its bid proposal, bidder(s) acknowledges and is bound by the entire Contract Documents, including any addenda issued thereto, as such Contract Documents incorporated by reference in the Bidding Documents.

**NON-COLLUSION AFFIDAVIT TO BE EXECUTED BY BIDDER AND SUBMITTED WITH BID UNDER 23
UNITED STATES CODE 112 AND PUBLIC CONTRACT CODE 7106**

State of California

County of San Diego

The bidder, being first duly sworn, deposes and says that he or she is authorized by the party making the foregoing bid that the bid is not made in the interest of, or on behalf of, any undisclosed person, partnership, company, association, organization, or corporation; that the bid is genuine and not collusive or sham; that the bidder has not directly or indirectly induced or solicited any other bidder to put in a false or sham bid, and has not directly or indirectly colluded, conspired, connived, or agreed with any bidder or anyone else to put in a sham bid, or that anyone shall refrain from bidding; that the bidder has not in any manner, directly or indirectly, sought by agreement, communication, or conference with anyone to fix the bid price of the bidder or any other bidder, or to fix any overhead, profit, or cost element of the bid price, or of that of any other bidder, or to secure any advantage against the public body awarding the contract of anyone interested in the proposed contract; that all statements contained in the bid are true; and further, that the bidder has not, directly or indirectly, submitted his or her bid price or any breakdown thereof, or the contents thereof, or divulged information or data relative thereto, or paid, and will not pay, any fee to any corporation, partnership, company association, organization, bid depository, or to any member or agent thereof to effectuate a collusive or sham bid.

CONTRACTOR CERTIFICATION

DRUG-FREE WORKPLACE

I hereby certify that I am familiar with the requirements of San Diego City Council Policy No. 100-17 regarding Drug-Free Workplace as outlined in the WHITEBOOK, Section 5-1.3, "Drug-Free Workplace", of the project specifications, and that;

This company has in place a drug-free workplace program that complies with said policy. I further certify that each subcontract agreement for this project contains language which indicates the subcontractor's agreement to abide by the provisions of subdivisions a) through c) of the policy as outlined.

CONTRACTOR CERTIFICATION

AMERICANS WITH DISABILITIES ACT (ADA) COMPLIANCE CERTIFICATION

I hereby certify that I am familiar with the requirements of San Diego City Council Policy No. 100-4 regarding the Americans With Disabilities Act (ADA) outlined in the WHITEBOOK, Section 5-1.2, "California Building Code, California Code of Regulations Title 24 and Americans with Disabilities Act", of the project specifications, and that:

This company has in place workplace program that complies with said policy. I further certify that each subcontract agreement for this project contains language which indicates the subcontractor's agreement to abide by the provisions of the policy as outlined.

CONTRACTOR CERTIFICATION

CONTRACTOR STANDARDS – PLEDGE OF COMPLIANCE

I declare under penalty of perjury that I am authorized to make this certification on behalf of the company submitting this bid/proposal, that as Contractor, I am familiar with the requirements of City of San Diego Municipal Code § 22.3004 regarding Contractor Standards as outlined in the WHITEBOOK, Section 5-1.4, ("Contractor Standards and Pledge of Compliance"), of the project specifications, and that Contractor has complied with those requirements.

I further certify that each of the Contractor's subcontractors has completed a Pledge of Compliance attesting under penalty of perjury of having complied with City of San Diego Municipal Code § 22.3004.

CONTRACTOR CERTIFICATION

EQUAL BENEFITS ORDINANCE CERTIFICATION

I declare under penalty of perjury that I am familiar with the requirements of and in compliance with the City of San Diego Municipal Code § 22.4300 regarding Equal Benefits Ordinance.

CONTRACTOR CERTIFICATION

EQUAL PAY ORDINANCE CERTIFICATION

Contractor shall comply with the Equal Pay Ordinance (EPO) codified in the San Diego Municipal Code (SDMC) at section 22.4801 through 22.4809, unless compliance is not required based on an exception listed in SDMC section 22.4804.

Contractor shall require all of its subcontractors to certify compliance with the EPO in their written subcontracts.

Contractor must post a notice informing its employees of their rights under the EPO in the workplace or job site.

By signing this Contract with the City of San Diego, Contractor acknowledges the EPO requirements and pledges ongoing compliance with the requirements of SDMC Division 48, section 22.4801 et seq., throughout the duration of this Contract.

AFFIDAVIT OF DISPOSAL

(To be submitted upon completion of Construction pursuant to the contracts Certificate of Completion)

WHEREAS, on the _____ DAY OF _____, 2____ the undersigned entered into and executed a contract with the City of San Diego, a municipal corporation, for:

WANGENHEIM NEIGHBORHOOD PARK JOINT USE FACILITY

(Project Title)

as particularly described in said contract and identified as Bid No. **K-21-1986-DBB-3**; SAP No. (WBS) **S-15007**; and **WHEREAS**, the specification of said contract requires the Contractor to affirm that "all brush, trash, debris, and surplus materials resulting from this project have been disposed of in a legal manner"; and **WHEREAS**, said contract has been completed and all surplus materials disposed of:

NOW, THEREFORE, in consideration of the final payment by the City of San Diego to said Contractor under the terms of said contract, the undersigned Contractor, does hereby affirm that all surplus materials as described in said contract have been disposed of at the following location(s)

and that they have been disposed of according to all applicable laws and regulations.

Dated this _____ DAY OF _____, _____.

By: _____
Contractor

ATTEST:

State of _____ County of _____

On this _____ DAY OF _____, 2____, before the undersigned, a Notary Public in and for said County and State, duly commissioned and sworn, personally appeared _____ known to me to be the _____ Contractor named in the foregoing Release, and whose name is subscribed thereto, and acknowledged to me that said Contractor executed the said Release.

Notary Public in and for said County and State

LIST OF SUBCONTRACTORS

***** PROVIDED FOR ILLUSTRATIVE PURPOSES ONLY *** TO BE SUBMITTED IN ELECTRONIC FORMAT ONLY*** SEE INSTRUCTIONS TO BIDDERS, FOR FURTHER INFORMATION**

In accordance with the requirements of the "Subletting and Subcontracting Fair Practices Act", Section 4100, of the California Public Contract Code (PCC), the Bidder is to list below the name, address and license number of each Subcontractor who will perform work, labor, render services or specially fabricate and install a portion [type] of the work or improvement, in an amount of or in excess of 0.5% of the Contractor's total Bid. Failure to comply with this requirement may result in the Bid being rejected as non-responsive. The Contractor is to list only one Subcontractor for each portion of the Work. The Bidder's attention is directed to the Special Provisions - Section 3-2, "SELF-PERFORMANCE", which stipulates the percentage of the Work to be performed with the Bidder's own forces. The Bidder is to also list all SLBE, ELBE, DBE, DVBE, MBE, WBE, OBE, SDB, WoSB, HUBZone, and SDVOSB Subcontractors for which the Bidders are seeking recognition towards achieving any mandatory, voluntary, or both subcontracting participation percentages.

NAME, ADDRESS AND TELEPHONE NUMBER OF SUBCONTRACTOR	CONSTRUCTOR OR DESIGNER	SUBCONTRACTOR LICENSE NUMBER	TYPE OF WORK	DOLLAR VALUE OF SUBCONTRACT	MBE, WBE, DBE, DVBE, OBE, ELBE, SLBE, SDB, WoSB, HUBZone, OR SDVOSB®	WHERE CERTIFIED®	CHECK IF JOINT VENTURE PARTNERSHIP
Name: _____ Address: _____ City: _____ State: _____ Zip: _____ Phone: _____ Email: _____							
Name: _____ Address: _____ City: _____ State: _____ Zip: _____ Phone: _____ Email: _____							

- ① As appropriate, Bidder shall identify Subcontractor as one of the following and shall include a valid proof of certification (except for OBE, SLBE and ELBE):
- | | | | |
|---|--------|--|---------|
| Certified Minority Business Enterprise | MBE | Certified Woman Business Enterprise | WBE |
| Certified Disadvantaged Business Enterprise | DBE | Certified Disabled Veteran Business Enterprise | DVBE |
| Other Business Enterprise | OBE | Certified Emerging Local Business Enterprise | ELBE |
| Certified Small Local Business Enterprise | SLBE | Small Disadvantaged Business | SDB |
| Woman-Owned Small Business | WoSB | HUBZone Business | HUBZone |
| Service-Disabled Veteran Owned Small Business | SDVOSB | | |
- ② As appropriate, Bidder shall indicate if Subcontractor is certified by:
- | | | | |
|--|--------|--|----------|
| City of San Diego | CITY | State of California Department of Transportation | CALTRANS |
| California Public Utilities Commission | CPUC | | |
| State of California's Department of General Services | CADoGS | City of Los Angeles | LA |
| State of California | CA | U.S. Small Business Administration | SBA |

The Bidder will not receive any subcontracting participation percentages if the Bidder fails to submit the required proof of certification.

NAMED EQUIPMENT/MATERIAL SUPPLIER LIST

***** PROVIDED FOR ILLUSTRATIVE PURPOSES ONLY *** TO BE SUBMITTED IN ELECTRONIC FORMAT ONLY *** SEE INSTRUCTIONS TO BIDDERS FOR FURTHER INFORMATION**

NAME, ADDRESS AND TELEPHONE NUMBER OF VENDOR/SUPPLIER	MATERIALS OR SUPPLIES	DOLLAR VALUE OF MATERIAL OR SUPPLIES	SUPPLIER (Yes/No)	MANUFACTURER (Yes/No)	MBE, WBE, DBE, DVBE, OBE, ELBE, SLBE, SDB, WoSB, HUBZone, OR SDVOSB ^①	WHERE CERTIFIED ^②
Name: _____ Address: _____ City: _____ State: _____ Zip: _____ Phone: _____ Email: _____						
Name: _____ Address: _____ City: _____ State: _____ Zip: _____ Phone: _____ Email: _____						

- ① As appropriate, Bidder shall identify Vendor/Supplier as one of the following and shall include a valid proof of certification (except for OBE, SLBE and ELBE):
- | | | | |
|---|--------|--|---------|
| Certified Minority Business Enterprise | MBE | Certified Woman Business Enterprise | WBE |
| Certified Disadvantaged Business Enterprise | DBE | Certified Disabled Veteran Business Enterprise | DVBE |
| Other Business Enterprise | OBE | Certified Emerging Local Business Enterprise | ELBE |
| Certified Small Local Business Enterprise | SLBE | Small Disadvantaged Business | SDB |
| Woman-Owned Small Business | WoSB | HUBZone Business | HUBZone |
| Service-Disabled Veteran Owned Small Business | SDVOSB | | |

- ② As appropriate, Bidder shall indicate if Vendor/Supplier is certified by:
- | | | | |
|--|--------|--|----------|
| City of San Diego | CITY | State of California Department of Transportation | CALTRANS |
| California Public Utilities Commission | CPUC | | |
| State of California's Department of General Services | CADoGS | City of Los Angeles | LA |
| State of California | CA | U.S. Small Business Administration | SBA |

The Bidder will not receive any subcontracting participation percentages if the Bidder fails to submit the required proof of certification.

ELECTRONICALLY SUBMITTED FORMS

FAILURE TO FULLY COMPLETE AND SUBMIT ANY OF THE FOLLOWING FORMS WILL DEEM YOUR BID NON-RESPONSIVE.

PLANETBIDS WILL NOT ALLOW FOR BID SUBMISSIONS WITHOUT THE ATTACHMENT OF THESE FORMS

The following forms are to be completed by the bidder and submitted (uploaded) electronically with the bid in PlanetBids.

- A. BID BOND – See Instructions to Bidders, Bidders Guarantee of Good Faith (Bid Security) for further instructions**
- B. CONTRACTOR’S CERTIFICATION OF PENDING ACTIONS**
- C. MANDATORY DISCLOSURE OF BUSINESS INTERESTS FORM**
- D. DEBARMENT AND SUSPENSION CERTIFICATION FOR PRIME CONTRACTOR**
- E. DEBARMENT AND SUSPENSION CERTIFICATION FOR SUBCONTRACTORS, SUPPLIERS AND MANUFACTURERS**

BID BOND

**See Instructions to Bidders, Bidder Guarantee of Good Faith
(Bid Security)**

KNOW ALL MEN BY THESE PRESENTS,

That TRI-GROUP CONSTRUCTION AND DEVELOPMENT, INC. as Principal, and NORTH AMERICAN SPECIALTY INSURANCE COMPANY as Surety, are held and firmly bound unto The City of San Diego hereinafter called "OWNER," in the sum of **10% OF THE TOTAL BID AMOUNT** for the payment of which sum, well and truly to be made, we bind ourselves, our heirs, executors, administrators, successors, and assigns, jointly and severally, firmly by these presents.

WHEREAS, said Principal has submitted a Bid to said OWNER to perform the WORK required under the bidding schedule(s) of the OWNER's Contract Documents entitled

WANGENHEIM NEIGHBORHOOD PARK JOINT USE FACILITY

NOW THEREFORE, if said Principal is awarded a contract by said OWNER and, within the time and in the manner required in the "Notice Inviting Bids" enters into a written Agreement on the form of agreement bound with said Contract Documents, furnishes the required certificates of insurance, and furnishes the required Performance Bond and Payment Bond, then this obligation shall be null and void, otherwise it shall remain in full force and effect. In the event suit is brought upon this bond by said OWNER and OWNER prevails, said Surety shall pay all costs incurred by said OWNER in such suit, including a reasonable attorney's fee to be fixed by the court.

SIGNED AND SEALED, this 25TH day of JANUARY, 2021

TRI-GROUP CONSTRUCTION AND DEVELOPMENT, INC. (SEAL)
(Principal)

NORTH AMERICAN SPECIALTY INSURANCE COMPANY (SEAL)
(Surety)

By: [Signature]
(Signature)
HANI ASSI, SECRETARY

By: [Signature]
(Signature)
SANDRA FIGUEROA, ATTORNEY-IN-FACT

(SEAL AND NOTARIAL ACKNOWLEDGEMENT OF SURETY)

CALIFORNIA ALL-PURPOSE ACKNOWLEDGMENT

CIVIL CODE § 1189

A notary public or other officer completing this certificate verifies only the identity of the individual who signed the document to which this certificate is attached, and not the truthfulness, accuracy, or validity of that document.

State of California }
County of SAN DIEGO

On 1/25/2021 before me, TRACY LYNN RODRIGUEZ, NOTARY PUBLIC
Date Here Insert Name and Title of the Officer

personally appeared SANDRA FIGUEROA
Name(s) of Signer(s)

who proved to me on the basis of satisfactory evidence to be the person(s) whose name(s) is/are subscribed to the within instrument and acknowledged to me that he/she/they executed the same in his/her/their authorized capacity(ies), and that by his/her/their signature(s) on the instrument the person(s), or the entity upon behalf of which the person(s) acted, executed the instrument.



I certify under PENALTY OF PERJURY under the laws of the State of California that the foregoing paragraph is true and correct.

WITNESS my hand and official seal.

Signature *Tracy Lynn Rodriguez*
Signature of Notary Public

Place Notary Seal and/or Stamp Above

OPTIONAL

Completing this information can deter alteration of the document or fraudulent reattachment of this form to an unintended document.

Description of Attached Document

Title or Type of Document: _____

Document Date: _____ Number of Pages: _____

Signer(s) Other Than Named Above: _____

Capacity(ies) Claimed by Signer(s)

Signer's Name: SANDRA FIGUEROA

Signer's Name: _____

Corporate Officer – Title(s): _____

Corporate Officer – Title(s): _____

Partner – Limited General

Partner – Limited General

Individual Attorney in Fact

Individual Attorney in Fact

Trustee Guardian of Conservator

Trustee Guardian of Conservator

Other: _____

Other: _____

Signer is Representing: _____

Signer is Representing: _____

CALIFORNIA ALL-PURPOSE ACKNOWLEDGMENT

CIVIL CODE § 1189

A notary public or other officer completing this certificate verifies only the identity of the individual who signed the document to which this certificate is attached, and not the truthfulness, accuracy, or validity of that document.

State of California }
County of SAN DIEGO }

On 1/26/2021 before me, TRACY LYNN RODRIGUEZ, NOTARY PUBLIC
Date Here Insert Name and Title of the Officer

personally appeared HANI ASSI
Name(s) of Signer(s)

who proved to me on the basis of satisfactory evidence to be the person(s) whose name(s) is/are subscribed to the within instrument and acknowledged to me that he/~~she~~/they executed the same in his/~~her~~/their authorized capacity(ies), and that by his/~~her~~/their signature(s) on the instrument the person(s), or the entity upon behalf of which the person(s) acted, executed the instrument.



I certify under PENALTY OF PERJURY under the laws of the State of California that the foregoing paragraph is true and correct.

WITNESS my hand and official seal.

Signature *Tracy Lynn Rodriguez*
Signature of Notary Public

Place Notary Seal and/or Stamp Above

OPTIONAL

Completing this information can deter alteration of the document or fraudulent reattachment of this form to an unintended document.

Description of Attached Document

Title or Type of Document: _____
Document Date: _____ Number of Pages: _____
Signer(s) Other Than Named Above: _____

Capacity(ies) Claimed by Signer(s)

Signer's Name: HANI ASSI Signer's Name: _____
 Corporate Officer – Title(s): SECRETARY Corporate Officer – Title(s): _____
 Partner – Limited General Partner – Limited General
 Individual Attorney in Fact Individual Attorney in Fact
 Trustee Guardian of Conservator Trustee Guardian of Conservator
 Other: _____ Other: _____
Signer is Representing: _____ Signer is Representing: _____

SWISS RE CORPORATE SOLUTIONS

NORTH AMERICAN SPECIALTY INSURANCE COMPANY
WASHINGTON INTERNATIONAL INSURANCE COMPANY
WESTPORT INSURANCE CORPORATION GENERAL POWER OF ATTORNEY

KNOW ALL MEN BY THESE PRESENTS, THAT North American Specialty Insurance Company, a corporation duly organized and existing under laws of the State of New Hampshire, and having its principal office in the City of Kansas City, Missouri and Washington International Insurance Company a corporation organized and existing under the laws of the State of New Hampshire and having its principal office in the City of Kansas City, Missouri, and Westport Insurance Corporation, organized under the laws of the State of Missouri, and having its principal office in the City of Kansas City, Missouri does hereby make, constitute and appoint:

JOHN G. MALONEY, HELEN MALONEY, SANDRA FIGUEROA, MARK D. IATAROLA, JESSICA SCHMAL AND TRACY LYNN RODRIGUEZ JOINTLY OR SEVERALLY

Its true and lawful Attorney(s)-in-Fact, to make, execute, seal and deliver, for and on its behalf and as its act and deed, bonds or other writings obligatory in the nature of a bond on behalf of each of said Companies, as surety, on contracts of suretyship as are or may be required or permitted by law, regulation, contract or otherwise, provided that no bond or undertaking or contract or suretyship executed under this authority shall exceed the amount of: ONE HUNDRED TWENTY FIVE MILLION (\$125,000,000.00) DOLLARS

This Power of Attorney is granted and is signed by facsimile under and by the authority of the following Resolutions adopted by the Boards of Directors of North American Specialty Insurance Company and Washington International Insurance Company at meetings duly called and held on March 24, 2000 and Westport Insurance Corporation by written consent of its Executive Committee dated July 18, 2011.

RESOLVED, that any two of the President, any Senior Vice President, any Vice President, any Assistant Vice President, the Secretary or any Assistant Secretary be, and each or any of them hereby is authorized to execute a Power of Attorney qualifying the attorney named in the given Power of Attorney to execute on behalf of the Company bonds, undertakings and all contracts of surety, and that each or any of them hereby is authorized to attest to the execution of any such Power of Attorney and to attach therein the seal of the Company; and it is

FURTHER RESOLVED, that the signature of such officers and the seal of the Company may be affixed to any such Power of Attorney or to any certificate relating thereto by facsimile, and any such Power of Attorney or certificate bearing such facsimile signatures or facsimile seal shall be binding upon the Company when so affixed and in the future with regard to any bond, undertaking or contract of surety to which it is attached.

By Steven P. Anderson, Senior Vice President of Washington International Insurance Company & Senior Vice President of North American Specialty Insurance Company & Senior Vice President of Westport Insurance Corporation
By Mike A. Ito, Senior Vice President of Washington International Insurance Company & Senior Vice President of North American Specialty Insurance Company & Senior Vice President of Westport Insurance Corporation

IN WITNESS WHEREOF, North American Specialty Insurance Company, Washington International Insurance Company and Westport Insurance Corporation have caused their official seals to be hereunto affixed, and these presents to be signed by their authorized officers this 19TH day of JUNE, 20 19.

North American Specialty Insurance Company
Washington International Insurance Company
Westport Insurance Corporation

State of Illinois
County of Cook

On this 19TH day of JUNE, 20 19, before me, a Notary Public personally appeared Steven P. Anderson, Senior Vice President of

Washington International Insurance Company and Senior Vice President of North American Specialty Insurance Company and Senior Vice President of Westport Insurance Corporation and Michael A. Ito Senior Vice President of Washington International Insurance Company and Senior Vice President of North American Specialty Insurance Company and Senior Vice President of Westport Insurance Corporation, personally known to me, who being by me duly sworn, acknowledged that they signed the above Power of Attorney as officers of and acknowledged said instrument to be the voluntary act and deed of their respective companies.



M. Kenny, Notary Public

I, Jeffrey Goldberg, the duly elected Vice President and Assistant Secretary of North American Specialty Insurance Company, Washington International Insurance Company and Westport Insurance Corporation do hereby certify that the above and foregoing is a true and correct copy of a Power of Attorney given by said North American Specialty Insurance Company, Washington International Insurance Company and Westport Insurance Corporation which is still in full force and effect.

IN WITNESS WHEREOF, I have set my hand and affixed the seals of the Companies this 25th day of JANUARY, 20 21.

Jeffrey Goldberg, Vice President & Assistant Secretary of Washington International Insurance Company & North American Specialty Insurance Company & Vice President & Assistant Secretary of Westport Insurance Corporation

CONTRACTOR'S CERTIFICATION OF PENDING ACTIONS

As part of its bid or proposal (Non-Price Proposal in the case of Design-Build contracts), the Bidder shall provide to the City a list of all instances within the past 10 years where a complaint was filed or pending against the Bidder in a legal or administrative proceeding alleging that Bidder discriminated against its employees, subcontractors, vendors or suppliers, and a description of the status or resolution of that complaint, including any remedial action taken.

CHECK ONE BOX ONLY.

- The undersigned certifies that within the past 10 years the Bidder has NOT been the subject of a complaint or pending action in a legal administrative proceeding alleging that Bidder discriminated against its employees, subcontractors, vendors or suppliers.
- The undersigned certifies that within the past 10 years the Bidder has been the subject of a complaint or pending action in a legal administrative proceeding alleging that Bidder discriminated against its employees, subcontractors, vendors or suppliers. A description of the status or resolution of that complaint, including any remedial action taken and the applicable dates is as follows:

DATE OF CLAIM	LOCATION	DESCRIPTION OF CLAIM	LITIGATION (Y/N)	STATUS	RESOLUTION/REMEDIAL ACTION TAKEN

TRI GROUP
~~HANI ASSI~~
CONSTRUCTION AND DEVELOPMENT, INC.

Contractor Name: _____

Certified By HANI ASSI Title SECRETARY OF CORPORATION
Name
 [Signature] Date 02-17-2021
Signature

USE ADDITIONAL FORMS AS NECESSARY

Mandatory Disclosure of Business Interests Form

BIDDER/PROPOSER INFORMATION

Legal Name		TRI-GROUP CONSTRUCTION AND DEVELOPMENT, INC.		DBA
Street Address	City	State	Zip	
9580 BLACK MOUNTAIN RD STE L	SAN DIEGO	CA	92126	
Contact Person, Title	Phone	Fax		
HANI ASSI, SECRETARY OF CORP.	618-689-0058	858-689-1594		

Provide the name, identity, and precise nature of the interest* of all persons who are directly or indirectly involved** in this proposed transaction (SDMC § 21.0103).

* The precise nature of the interest includes:

- the percentage ownership interest in a party to the transaction,
- the percentage ownership interest in any firm, corporation, or partnership that will receive funds from the transaction, the value of any financial interest in the transaction,
- any contingent interest in the transaction and the value of such interest should the contingency be satisfied, and any philanthropic, scientific, artistic, or property interest in the transaction.

** Directly or indirectly involved means pursuing the transaction by:

- communicating or negotiating with City officers or employees,
- submitting or preparing applications, bids, proposals or other documents for purposes of contracting with the City, or directing or supervising the actions of persons engaged in the above activity.

Name	Title/Position
GHASSAN "GUS" ASSI	PRESIDENT / SUPERINTENDENT
City and State of Residence	Employer (if different than Bidder/Proposer)
ESCONDIDO, CA	(N/A)
Interest in the transaction	
OWNS 50% OF TRI-GROUP'S SHARES - BIDDER	

Name	Title/Position
HANI ASSI	SECRETARY OF CORP / PROJECT MANAGER
City and State of Residence	Employer (if different than Bidder/Proposer)
SAN DIEGO, CA	(N/A)
Interest in the transaction	
OWNS 50% OF TRI-GROUP'S SHARES - BIDDER	

* Use Additional Pages if Necessary *

Under penalty of perjury under the laws of the State of California, I certify that I am responsible for the completeness and accuracy of the responses contained herein, and that all information provided is true, full and complete to the best of my knowledge and belief. I agree to provide written notice to the Mayor or Designee within five (5) business days if, at any time, I learn that any portion of this Mandatory Disclosure of Business Interests Form requires an updated response. Failure to timely provide the Mayor or Designee with written notice is grounds for Contract termination.

HANI ASSI, SECRETARY OF CORP.

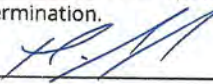

02-17-2021

Print Name, Title

Signature

Date

Failure to sign and submit this form with the bid/proposal shall make the bid/proposal non-responsive. In the case of an informal solicitation, the contract will not be awarded unless a signed and completed Mandatory Disclosure of Business Interests Form is submitted.

DEBARMENT AND SUSPENSION CERTIFICATION
PRIME CONTRACTOR
FAILURE TO COMPLETE AND SUBMIT AT TIME OF BID SHALL RENDER BID NON-RESPONSIVE

EFFECT OF DEBARMENT OR SUSPENSION
To promote integrity in the City's contracting processes and to protect the public interest, the City shall only enter into contracts with responsible- bidders and contractors. In accordance with San Diego Municipal Code §22.0814 (a): <i>Bidders and contractors</i> who have been <i>debarred</i> or <i>suspended</i> are excluded from submitting bids, submitting responses to requests for proposal or qualifications, receiving <i>contract awards</i> , executing <i>contracts</i> , participating as a <i>subcontractor</i> , employee, agent or representative of another <i>person</i> contracting with the City.

As part of its bid or proposal (Non-Price Proposal in the case of Design-Build contracts), the Bidder shall provide to the City a list of Names of the Principal Individual owner(s).

The names of all persons interested in the foregoing proposal as Principals are as follows:

NAME	TITLE
GHASSAN "Gus" ASSI	PRESIDENT
HANI ASSI	SECRETARY & CORPORATION

IMPORTANT NOTICE: If Bidder or other interested person is a corporation, state secretary, treasurer, and manager thereof; if a co-partnership, state true name of firm, also names of all individual co-partners composing firm; if Bidder or other interested person is an individual, state first and last names in full.

The Bidder, under penalty of perjury, certifies that, except as noted below, he/she or any person associated therewith in the capacity of owner, partner, director, officer, manager:

- Is not currently under suspension, debarment, voluntary exclusion, or determination of ineligibility by any Federal, State or local agency;
- has not been suspended, debarred, voluntarily excluded or determined ineligible by any Federal, State or local agency within the past 3 years;
- does not have a proposed debarment pending; and
- has not been indicted, convicted, or had a civil judgment rendered against it by a court of competent jurisdiction in any matter involving fraud or official misconduct within the past 3 years.

If there are any exceptions to this certification, insert the exceptions in the following space.

Exceptions will be considered in determining bidder responsibility. For any exception noted above, indicate below to whom it applies, initiating agency, and dates of action.

**TRI-GROUP
CONSTRUCTION AND
DEVELOPMENT, INC.**

Contractor Name: _____

Certified By HANI ASSI Title SECRETARY OF CORP.

Name

 Signature

Date 02-17-2021

NOTE: Providing false information may result in criminal prosecution or administrative sanctions.

1 of 3

**DEBARMENT AND SUSPENSION CERTIFICATION
SUBCONTRACTORS, SUPPLIERS AND MANUFACTURERS**

TO BE COMPLETED BY BIDDER

FAILURE TO COMPLETE AND SUBMIT AT TIME OF BID SHALL RENDER BID NON-RESPONSIVE

Names of the Principal individual owner(s)

As part of its bid or proposal (Non-Price Proposal in the case of Design-Build contracts), the Bidder shall provide to the City a list of Names of the Principal Individual owner(s) for their subcontractor/supplier/manufacturers.

Please indicate if principal owner is serving in the capacity of **subcontractor, supplier, and/or manufacturer:**

SUBCONTRACTOR SUPPLIER MANUFACTURER

NAME	TITLE
CRAFTSMAN FENCE	
JARRET YOUNG	PRESIDENT

SUBCONTRACTOR SUPPLIER MANUFACTURER

NAME	TITLE
PRECISION STRAPPING	
TIMOTHY HANW	PRESIDENT

SUBCONTRACTOR SUPPLIER MANUFACTURER

NAME	TITLE
G. SCOTT ASPHALT, INC	
DAN WEMPLE	PRESIDENT

SUBCONTRACTOR SUPPLIER MANUFACTURER

NAME	TITLE
IN-DEPTA ENVIRONMENTAL, INC	
CHARLES WELK	PRESIDENT

Contractor Name: TRI-GROUP CONSTRUCTION AND DEVELOPMENT, INC.

Certified By: HANI ASSI Title SECRETARY OF CORP.

Name _____

Signature _____ Date 02-17-2021

USE ADDITIONAL FORMS AS NECESSARY*

2 of 3

**DEBARMENT AND SUSPENSION CERTIFICATION
SUBCONTRACTORS, SUPPLIERS AND MANUFACTURERS**

TO BE COMPLETED BY BIDDER

FAILURE TO COMPLETE AND SUBMIT AT TIME OF BID SHALL RENDER BID NON-RESPONSIVE

Names of the Principal individual owner(s)

As part of its bid or proposal (Non-Price Proposal in the case of Design-Build contracts), the Bidder shall provide to the City a list of Names of the Principal Individual owner(s) for their subcontractor/supplier/manufacturers.

Please indicate if principal owner is serving in the capacity of **subcontractor, supplier, and/or manufacturer:**

SUBCONTRACTOR SUPPLIER MANUFACTURER

NAME	TITLE
MTGL, INC	
STEVEN KOCH	PRESIDENT

SUBCONTRACTOR SUPPLIER MANUFACTURER

NAME	TITLE
SPECTRA TRF	
ARTHUR DODGE	PRESIDENT

SUBCONTRACTOR SUPPLIER MANUFACTURER

NAME	TITLE
WEBER PLUMBING	
JUSTIN WEBER	PRESIDENT

SUBCONTRACTOR SUPPLIER MANUFACTURER

NAME	TITLE
ACE ELECTRIC	
JERRY HINDS	PRESIDENT

Contractor Name: TRI-GROUP CONSTRUCTION AND DEVELOPMENT, INC.

Certified By: HANI ASSI Title SECRETARY & CORP.

Name
[Signature]
Signature Date 02-17-2021

USE ADDITIONAL FORMS AS NECESSARY*

393

DEBARMENT AND SUSPENSION CERTIFICATION
SUBCONTRACTORS, SUPPLIERS AND MANUFACTURERS
TO BE COMPLETED BY BIDDER

FAILURE TO COMPLETE AND SUBMIT AT TIME OF BID SHALL RENDER BID NON-RESPONSIVE

Names of the Principal individual owner(s)

As part of its bid or proposal (Non-Price Proposal in the case of Design-Build contracts), the Bidder shall provide to the City a list of Names of the Principal Individual owner(s) for their subcontractor/supplier/manufacturers.

Please indicate if principal owner is serving in the capacity of **subcontractor**, **supplier**, and/or **manufacturer**:

SUBCONTRACTOR SUPPLIER MANUFACTURER

NAME	TITLE
LUBER MECHANICAL	
VADIM LYUBER	PRESIDENT

SUBCONTRACTOR SUPPLIER MANUFACTURER

NAME	TITLE
PGC CONSTRUCTION INC	
REGINA CHAPMAN	PRESIDENT

SUBCONTRACTOR SUPPLIER MANUFACTURER

NAME	TITLE
VORTEX	
ELIZABETH TURNER	PRESIDENT

SUBCONTRACTOR SUPPLIER MANUFACTURER

NAME	TITLE
VASQUEZ CONSTRUCTION COMPANY	
MANUEL VASQUEZ	PRESIDENT

Contractor Name: TRI-GROUP CONSTRUCTION AND DEVELOPMENT, INC.

Certified By: HANI ASSI Title SECRETARY OF CORP.

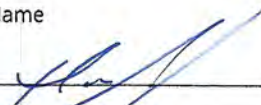
Name

Signature

Date 02-17-2021

USE ADDITIONAL FORMS AS NECESSARY*

City of San Diego

CITY CONTACT: Juan E. Espindola, Senior Contract Specialist, Email: JEEspindola@sandiego.gov

Phone No. (619) 533-4491

ADDENDUM A



FOR

WANGENHEIM NEIGHBORHOOD PARK JOINT USE FACILITY

BID NO.:	K-21-1986-DBB-3
SAP NO. (WBS/IO/CC):	S-15007
CLIENT DEPARTMENT:	1714
COUNCIL DISTRICT:	6
PROJECT TYPE:	GB, GF, BS

BID DUE DATE:

**2:00 PM
JANUARY 14, 2021**

CITY OF SAN DIEGO'S ELECTRONIC BIDDING SITE, PLANETBIDS

<http://www.sandiego.gov/cip/bidopps/index.shtml>

A. CHANGES TO CONTRACT DOCUMENTS

The following changes to the Contract Documents are hereby made effective as though originally issued with the bid package. Bidders are reminded that all previous requirements to this solicitation remain in full force and effect.

THE SUBMITTAL DATE FOR THIS PROJECT HAS BEEN **EXTENDED AS STATED ON THE COVER PAGE.**

James Nagelvoort, Director
Engineering & Capital Projects Department

Dated: *December 8, 2020*
San Diego, California

JN/RWB/rd

City of San Diego

CITY CONTACT: Juan E. Espindola, Senior Contract Specialist, Email: JEEspindola@sandiego.gov

Phone No. (619) 533-4491

ADDENDUM B



FOR

WANGENHEIM NEIGHBORHOOD PARK JOINT USE FACILITY

BID NO.:	<u>K-21-1986-DBB-3</u>
SAP NO. (WBS/IO/CC):	<u>S-15007</u>
CLIENT DEPARTMENT:	<u>1714</u>
COUNCIL DISTRICT:	<u>6</u>
PROJECT TYPE:	<u>GB, GF, BS</u>

BID DUE DATE:

**2:00 PM
FEBRUARY 2, 2021**

CITY OF SAN DIEGO'S ELECTRONIC BIDDING SITE, PLANETBIDS

<http://www.sandiego.gov/cip/bidopps/index.shtml>

ENGINEER OF WORK

The Engineering Specifications and Special Provisions contained herein have been prepared by or under the direction of the following Registered Engineers:

Kan On J

1) Registered Engineer

12-28-20

Date

Seal:



Jason Grant

2) For City Engineer

1/12/2021

Date

Seal:



A. CHANGES TO CONTRACT DOCUMENTS

The following changes to the Contract Documents are hereby made effective as though originally issued with the bid package. Bidders are reminded that all previous requirements to this solicitation remain in full force and effect.

THE SUBMITTAL DATE FOR THIS PROJECT HAS BEEN **EXTENDED AS STATED ON THE COVER PAGE.**

B. BIDDER'S QUESTIONS

Q1. Plan C-10 does not indicate the presence & removal of tree and shrubs at the end of Flanders Drive. Will tree and shrubs protection, removal, and/or replacement be a part of this project.

A1. Please see the revised D-4 sheet showing the revised call outs for the tree and shrubs at the end of Flanders Drive.

Q2. Plan C-10, The domestic water feed for concession standpipe is indicated as 3". The feed source for this line is off a 1" meter, which will be upsized meter only to 1.5". Please confirm if the pipeline to concession stand is correct at 3" and specify material type as this is an odd and uncommon diameter. We suggest a 1.5" diameter of schedule 40 or copper max to match the upsized meter.

A2. Install 3" Class 315 PVC per Plan Sheets. L-11, L-13 & L-14 and per Irrigation Legend Sht. L-16.

Q3. Please provide a connection detail for the two 2" lines connecting to the existing recycled water main on Flanders. Will these be tapped to existing main by City of SD per a Fee Schedule? The plans indicate a 2" diameter extension off of the existing main prior to perpendicular 2" services.

A3. Please see connection detail (RFI_3) for two 2" irrigation laterals.

Q4. Plans indicate to CCTV existing lateral prior to connection of new lateral. The new lateral connects to an existing manhole. Please confirm this note does not apply to installation plan for this project or clarify length of existing main to CCTV.

A4. This note does not apply to our project because our sewer alignment does not have any existing sewer laterals connection to it. Therefore, CCTV is not needed.

Q5. Please confirm that excavation and replacement of import topsoil is required. Detail A on Drawing L-28 shows 10" of topsoil is required. Page 60 of Specification

A5. Confirmed.

Q6. What is the thickness of the asphalt and base on the Parking Lot as shown on Drawing C-13?

A6. The pavement thickness is 4.0" AC over 8" Class II Base per the soils report.

C. NOTICE INVITING BIDS

1. To Item 3, **ESTIMATED CONSTRUCTION COST**, page 6, **DELETE** in its entirety and **SUBSTITUTE** with the following:

3. **ESTIMATED CONSTRUCTION COST:** The City's estimated total construction cost for this project is **\$6,849,200**.

D. SUPPLEMENTARY SPECIAL PROVISIONS

1. To Section 3-9, TECHNICAL STUDIES AND SUBSURFACE DATA, page 37, **DELETE** in its entirety and **SUBSTITUTE** with the following:

3-9 TECHNICAL STUDIES AND SUBSURFACE DATA. To the "WHITEBOOK", ADD the following:

5. In preparation of the Contract Documents, the designer has relied upon the following reports of explorations and tests at the Work Site:

a) Report of Geotechnical Investigation Wangenheim Joint Use Facility, Dated February 7, 2017, April 22, 2019, Updated on April 24, 2019 by Allied Geotechnical Engineers, Inc.

b) Drainage Study, Dated June 1, 2018, Revised January 25, 2019, Revised August 16, 2019 by Rick Engineering.

c) Response to City of San Diego Development Services Department Review Comments Pertaining to Report of Geotechnical Investigation Wangenheim Joint Use Facility, Dated April 22, 2019, Updated on April 24, 2019.

- d) Review of Shade Structure Foundation Design Wangenheim Joint Use Facility, Dated October 14, 2019, by Allied Geotechnical Engineers, Inc.
- e) Structural Calculations for Wangenheim Joint Use Facility, by Orion.
- f) Structural Calculations for Wangenheim Joint Use Facility - Addendum A: Response to DSA Comments, by Orion
- g) Priority Development Project Storm Water Quality Management Plan, Dated June 01, 2018, Revised Sep. 04, 2018, Revised January 25, 2019, by Rick Engineering Inc.
- h) Infiltration Feasibility Form I-8 & I-9 dated May 21, 2019, by Rich Engineering Inc.

6. The reports listed above are available for review at the following link:

<https://drive.google.com/drive/folders/1ytqgejTpS0WiYSXUM7iYcl7dgquCk4U>

2. To SECTION 300 – EARTHWORK, page 55, **ADD** the following:

300-4.1 "Geotechnical (soil) testing of all fill materials; subgrade, subbase, and base will be conducted by the Contractor's Geotechnical Engineer. Geotechnical (soil) tests may include relative compaction tests, sand equivalent tests, sieve analysis, R-values, etc. The results shall be presented directly by the laboratory to the City Engineer. No base or PCC pavement shall be placed prior to the subgrade or subbase being compacted, tested and approved by the City Engineer."

"The cost of any geotechnical (soil) tests shall be borne by the Contractor. Additional geotechnical (soil) tests due to the failure of one (1) or more of the initial tests shall be conducted by the laboratory and any costs borne by the Contractor. The Contractor shall make allowances in his construction procedure to permit testing of the Work in progress by the

City Engineer, and no additional compensation shall be paid to the Contractor for delays due to testing.”

3. To APPENDICES, Appendix I, MUNITION OF EXPLOSIVE CONCERN SPECIFICATIONS, pages 597 thru 601, **DELETE** in their entirety and **SUBSTITUTE** with pages 7 to 10 of this addendum.

2. PLANS

1. To Drawing Numbers 40846-1-D through 40846-2-D, 40846-10-D through 40846-14-D, 40846-16-D through 40846-17-D, 40846-22-D through 40846-26-D, 40846-28-D, 40846-33-D through 40846-37-D, 40846-39-D, 40846-41-D, 40846-43-D, 40846-46-D through 40846-50-D, 40846-75-D through 40846-77-D, 40846-79-D through 40846-81-D, 40846-85-D, 40846-100-D, 40846-104-D, 40846-108-D, 40846-113-D, 40846-117-D, 40846-118-D, 40846-130-D through 40846-133-D, 40846-137-D, **DELETE** in their entirety and **REPLACE** with pages 11 through 56 of this addendum.

James Nagelvoort, Director
Engineering & Capital Projects Department

Dated: *January 12, 2021*
San Diego, California

JN/RWB/rd

Munition of Explosive Concern/Unexploded Ordnance Support Wangenheim Neighborhood Joint Use Facility

This document provides background information regarding the former Linda Vista Valley Auxiliary Bomb Site and bid specifications for providing Munition of Explosive Concern (MEC) and Unexploded Ordnance construction support during construction activities for the Wangenheim Neighborhood Joint Use Facility.

BACKGROUND

The Department of Defense (DoD) is responsible for environmental restoration of properties that were formerly owned by, leased to, or otherwise possessed by the United States and under the jurisdiction of the Secretary of Defense prior to October 1986 (i.e. FUDS properties). The United States Army Corps of Engineers (USACE) manages and directs the FUDS program's administration. USACE Los Angeles District (CESPL) is responsible for the Linda Vista Valley Auxiliary Field Formally Used Defense Site (Linda Vista FUDS).

The Linda Vista FUDS is located approximately one mile north of Marine Corps Air Station Miramar (formally Naval Air Station [NAS] Miramar) and west of Interstate 15. It consists of approximately 215 acres located in the community of Mira Mesa within the City and County of San Diego. The City of San Diego, San Diego Unified School District (SDUSD), San Diego Community College District (SDCCD), and private property owners own parcels located within the Linda Vista FUDS site. The Linda Vista FUDS site also encompasses two mobile home parks (The Woods Mobilehome Park and Village Green Mobilehome Park) developed in the late-1960s.

Acquisition of the Linda Vista Valley Auxiliary Field began in 1931 when the Chief of the Bureau of Aeronautics leased 640 acres north of Camp Kearney. A portion of the acreage was to be used as an Auxiliary Flying Field to support NAS San Diego. The Navy acquired about 170 (of the original 640 acres) in 1941 for continued use as an outlying field. In 1942, the Navy acquired an additional 43 acres (also of the original 640 acres) for use as a practice bombing target. At one point in time the property was used for the storage of surplus buildings. The Navy disposed of the original 170 acres in August 1961 by quit claim deed to San Diego School District. The remaining 43.11 acres were auctioned off in 1962 to a private developer. Military related improvements reportedly consisted of an asphalt surface of approximately 65 acres, some fencing, and the practice bomb target.

The CESPL began investigating the Linda Vista Valley Auxiliary Field site in 1997, with the 1997 Inventory Project Report (INPR) which established the Linda Vista Valley Auxiliary site as a FUDS with assigned Project Number J09CA723601. The INPR recommended an investigation to evaluate the presence of MEC. In 2001 an Archives Search Report (ASR) was completed by the U.S. Army Corps of Engineers, Rock Island District (CEMVR) and in 2004 an ASR Supplement was completed which recalculated and established the current acreage of the Linda Vista Valley Auxiliary Field site to be 72 acres.

In March of 2009 a Site Inspection Report was published documenting the MEC and munition constituents (MC) field investigation results, data analysis results, and recommendation. The Department of Toxic Substances Control (DTSC) reviewed the report and recommendation to proceed to the Remedial Investigation and Feasibility Study (RI/FS) phase for Practice Bomb Target 1 (PBT 1) and AOI Target 2. Since this letter was issued, no documentation has been located to demonstrate that the recommended sampling or site closure activities have been conducted for the Linda Vista FUDS. Although no munitions

and explosives of concern (MEC) or munitions debris (MD) were observed during the SI field effort for PBT 1 and AOI Target 2, munitions were reported to be used at the FUDS. The length of time the munitions were used is not documented; however historical records indicate that military munitions used at the FUDS included 3 and 4-pound miniature practice bombs (specifically, AN-Mk 5, AN-Mk 23, AN-Mk 43 practice bombs).

The San Diego Fire Department's Bomb Squad reported that ten AN-Mk 5 practice bombs were discovered during modernization projects recently completed at Miramar Community College which is located on the opposite side of Black Mountain Road from the proposed park project. Because of the potential of encountering the referenced ordnance, MEX/UXO construction support is warranted at the Site.

SCOPE OF WORK

Task 1 – Pre-Construction MEC/UXO Awareness Meeting

The MEC/UXO Contractor will conduct a MEC/UXO awareness session with contract personnel that will be conducting grading and/or ground-disturbing activities. The Munition Response Plan for the Wangenheim Joint Use Facility will serve as the basis for the awareness training. Topics will focus on Recognize, Retreat, and Report Protocol as well as an Avoidance Protocol. The awareness meeting will be conducted two days before field activities start. For the purpose of this scope of work, assume that the duration of the meeting will be no more than 90 minutes. The MEC/UXO Contractor is expected to provide all necessary materials for the awareness meeting. A log of attendees will be maintained by the MEC/UXO Contractor to verify that all site personnel attended the awareness meeting. Relevant discussion topics during the training include the following bullets at a minimum.

- Identify the Point of Contacts (POC) including but not limited to:
 - USACE contact for SDUSD inquiries and response action to discovered Munitions Explosive Concern (MEC).
 - City of San Diego representatives.
 - SDUSD representative to handle any faculty/parent/contractor inquiries and lead response action to discovered MEC.
 - School Principals or other school representatives.
- Review Implementation Procedures
 - Awareness Briefing and Notification – MEC/UXO contractor may request that the San Diego Fire Department Bomb Squad participate in a UXO Awareness Briefing informing the construction personnel of the potential ordnance hazards and the precautions to be taken.
 - An action plan will be developed to describe the response in case of MEC discovery. The action plan will specify contacts at Marine Corps Air Station (MCAS) – Miramar and the San Diego Fire Department (SDFD).
- Worker MEC briefing materials would include the following:
 - Contractor Ordnance Info Sheet
 - Contractor Fact Sheet

Revised - Task 2 – Detector-Aided Visual Survey and Reporting

A qualified UXO Technician III will conduct a detector-aided visual survey of all areas where ground-disturbing activities would be conducted. Ground-disturbing activities include but are not limited to excavating, digging, drilling, auguring, trenching, grading, etc. Prior to conducting any ground disturbing activities, the UXO Technician may screen the work area using appropriate UXO/MEC/MD detectors for possible anomalies that could indicate the presence of MEC/UXO/MD.

The project area will be protected by a security fence to prevent visitors to the park area from entering the project area. Any anomalies detected by the UXO Support team that are suspected to be UXO, MEC, or MD will be marked at the surface with plastic pin flags. If suspect MEC/UXO/MD is encountered, the UXO personnel will attempt to visually identify the item and to gather additional information such as the munitions type. The item will be marked with a yellow survey marker flag and given a unique ID number. All available information about the item will be recorded in the logbook/Daily MEC Accountability Log, including the suspect MEC location, description, and ID number. Additionally, a digital photograph will be taken of each item.

If the UXO Technician determines that the anomaly represents a possible MEC/UXO/MD, the UXO Technician should implement the protocol described in the Munition Response Plan. If the anomaly cannot be identified, the UXO Technician will notify the contractor of the presence and location of the anomaly. All ground disturbing activities conducted in the vicinity of the anomaly will be observed as described in Task 3. The UXO Technician or any other site personnel is not approved to remove, handle, touch, or disturb any item that is suspected to be MEC, UXO, or MD. Instead, the MEC contractor will notify the San Diego Fire Department Bomb Squad of the suspected items.

Any scrap metal suspected to be MEC or MDEH that is encountered will be certified free of explosive material by the San Diego Fire Department or qualified personnel from the Army Corps of Engineers or Department of Defense prior to transfer. Handling, transport, and storage of MDAS will be conducted by ACOE or DOD representatives in accordance with applicable rules and procedures.

Revised Task 3 – MEC/UXO Construction Support

During all site ground disturbing activities (including but not limited to excavation, drilling, auguring, trenching, grading, deep footings, etc.), the MEC/UXO Construction Support contractor will provide a qualified UXO Technician or a UXO Support team with appropriate MEC/UXO/MD screening equipment to serve as escorts to the construction contractor during all ground disturbing activities to inspect the construction contractor work area for possible hazards associated with MEC/UXO/MD. MEC/UXO personnel will use visual protocol and specialized metal detecting equipment to inspect the grading/intrusive work area for possible MEC/UXO/MD. Metal detecting equipment may include a Schonstedt GA-53CX or equivalent.

The UXO Technician will conduct daily safety briefings with the contract personnel to review safety procedures and identify work areas. A daily log will be maintained to track daily activities, site personnel, observations, and findings.

If suspect MEC/UXO/MD is encountered during construction activities, the UXO personnel will mark the location of the MEC/UXO/MD item and move all construction personnel to a safe staging area in accordance with the Munitions Response Plan. The MEC/UXO Contractor will be responsible for implementing the protocol described in the Munitions Response Plan. These protocols include contacting the San Diego Fire Department Bomb Squad to identify, secure, and remove the item discovered. If the item is determined to be MD or scrap metal, the item will be collected and stored for subsequent offsite disposal. The UXO Technician or any site personnel may not touch, move, handle, or disturb any MEC, UXO, or MD that is encountered. After the MEC/UXO/MD item has been removed or determined to not present an explosive hazard, the UXO Technician will notify the City of the disposition of the MEC/UXO/MD item and recommend that the contractors may return to work.

After the site has been determined to be safe by the San Diego County Fire Department or appropriate responsible agency, the MEC/UXO Contractor will prepare an After Action Report to document that the munitions response is complete at the school site. The After Action Report will provide a summary of UXO/MEC/MD items found and/or recovered, include mapped locations where they were encountered, and actions taken to neutralize material encountered during screening activities.

Task 4 – Field Summary Report

Within 10 working days of completing Task 3 Construction Support activities, the contractor will provide a Field Summary Report describing the field activities. The Field Summary Report will include figures and tables depicting the site activities and observations. At a minimum, the Field Summary Report will include:

- Identification of the MEC/UXO Construction Support personnel on site.
- Description of the activities conducted, and work area observed.
- A summary of daily activities and observations. Daily log sheets will be provided as an appendix to the summary report.
- Description(s) of MEC/UXO encountered including maps and photographs of MEC/UXO/MD encountered and documenting the location of the item(s) encountered.
- A description of response actions.
- Daily photographs provided as an appendix

One electronic copy of the Field Summary Report will be provided in PDF format.

Qualifications

MEC Inspection team will be led by a UXO Technician Level III qualified personnel.

WANGENHEIM NEIGHBORHOOD JOINT USE FACILITY

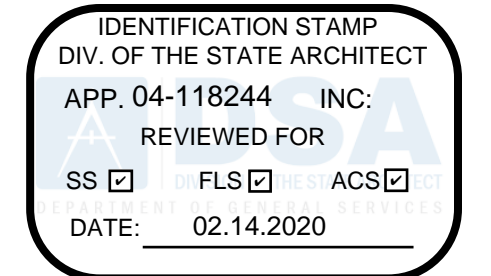

ROOM AREA AND OCCUPANT LOAD SCHEDULE

#	NAME	AREA	OCCUPANCY	OCCUPANT LOAD FACTOR	OCCUPANT LOAD
101	CONCESSION ROOM	173 SF	B	100 GROSS	2
102	STORAGE ROOM	290 SF	B	300 GROSS	1
103	PLUMBING CHASE	83 SF	B	300 GROSS	1
104	ELECTRICAL ROOM	28 SF	B	300 GROSS	1
105	TYPICAL ALL-GENDER RESTROOM	18 SF	B	N/A	N/A
106	ACCESSIBLE ALL-GENDER RESTROOM	40 SF	B	N/A	N/A
107	ACCESSIBLE ALL-GENDER RESTROOM	40 SF	B	N/A	N/A
108	TYPICAL ALL-GENDER RESTROOM	18 SF	B	N/A	N/A
109	AMBULATORY ACCESSIBLE ALL-GENDER RESTROOM	16 SF	B	N/A	N/A
110	ACCESSIBLE ALL-GENDER RESTROOM	40 SF	B	N/A	N/A
111	FAMILY RESTROOM	53 SF	B	N/A	N/A

CODES, STANDARDS AND SPECIFICATIONS

PARTIAL LIST OF APPLICABLE CODES AS OF JANUARY 1, 2017*:

2016 CALIFORNIA ADMINISTRATIVE CODE (CAC), PART 1, TITLE 24 CCR*
 2016 CALIFORNIA BUILDING CODE (CBC), PART 2, TITLE 24 CCR
 (2015 INTERNATIONAL BUILDING CODE, VOL. 1 & 2, AND 2016 CALIFORNIA AMENDMENTS)
 2016 CALIFORNIA ELECTRICAL CODE (CEC), PART 3, TITLE 24 CCR
 (2014 NATIONAL ELECTRIC CODE AND 2016 CALIFORNIA AMENDMENTS)
 2016 CALIFORNIA MECHANICAL CODE (CMC), PART 4, TITLE 24 CCR
 (2015 IAPMO UNIFORM MECHANICAL CODE AND 2016 CALIFORNIA AMENDMENTS)
 2016 CALIFORNIA PLUMBING CODE (CPC), PART 5, TITLE 24 CCR
 (2015 IAPMO UNIFORM PLUMBING CODE AND 2016 AMENDMENTS)
 2016 CALIFORNIA ENERGY CODE, PART 6, TITLE 24 CCR
 2016 CALIFORNIA FIRE CODE, PART 9, TITLE 24 CCR
 (2015 INTERNATIONAL FIRE CODE AND 2016 CALIFORNIA AMENDMENTS)
 2016 EXISTING BUILDING CODE (CEBC), PART 10, TITLE 24 CCR
 (2015 INTERNATIONAL EXISTING BUILDING CODE AND 2016 CALIFORNIA AMENDMENTS)
 2016 CALIFORNIA GREEN BUILDING STANDARDS CODE (CALGreen), PART 11, TITLE 24 CCR
 2016 CALIFORNIA REFERENCED STANDARDS, PART 12, TITLE 24 CCR
 AND AMENDMENTS IN SAN DIEGO MUNICIPAL CODE, JULY 2013
 TITLE 19 CCR, PUBLIC SAFETY, STATE FIRE MARSHAL REGULATIONS
 2013 ASME A17.1 / CSA B44-13 SAFETY CODE FOR ELEVATORS AND ESCALATORS

PARTIAL LIST OF APPLICABLE STANDARDS:

NFPA 13 STANDARD FOR INSTALLATION OF SPRINKLER SYSTEMS (CA AMENDED) 2016 ED.
 NFPA 14 STANDARD FOR INSTALLATION OF STANDPIPE AND HOSE SYSTEMS, 2013 ED.
 NFPA 17 STANDARD FOR DRY CHEMICAL EXTINGUISHING SYSTEMS, 2013 ED.
 NFPA 17A STANDARD FOR WET CHEMICAL EXTINGUISHING SYSTEMS, 2013 ED.
 NFPA 20 STANDARD FOR THE INSTALLATION OF STATIONARY PUMPS FOR FIRE PROTECTION, 2016 ED.
 NFPA 22 STANDARD FOR WATER TANKS FOR PRIVATE FOR PROTECTION, 2013 ED.
 NFPA 24 STANDARD FOR INSTALLATION OF PRIVATE FIRE SERVICE MAINS AND THEIR APPURTENANCES, 2016 ED.
 NFPA 72 NATIONAL FIRE ALARM AND SIGNALING CODE (CA. AMENDED) 2016 ED.
 (SEE UL STANDARD 1971 FOR VISUAL DEVICES)
 NFPA 80 STANDARD FOR FIRE DOORS AND OTHER OPENING PROTECTIVES, 2016 ED.
 NFPA 2001 STANDARD FOR CLEAN AGENT FIRE EXTINGUISHING SYSTEMS 2015 ED.
 UL 300 STANDARD FOR FIRE TESTING OF FIRE EXTINGUISHING SYSTEMS FOR PROTECTION OF COMMERCIAL COOKING EQUIPMENT, 2005 (2010)
 UL 464 AUDIBLE SIGNALING DEVICES FOR FIRE ALARM AND SIGNALING SYSTEMS, INCLUDING ACCESSORIES, 20013 ED.
 UL 521 STANDARD FOR HEAT DETECTORS FOR FIRE PROTECTIVE SIGNALING SYSTEMS, 1999 ED.
 UL 1971 STANDARD FOR SIGNALING DEVICES FOR THE HEARING IMPAIRED, 2002 ED.
 ICC 300 STANDARD FOR BLEACHERS, FOLDING AND TELESCOPING SEATING AND GRANDSTANDS, 2012 ED.

FOR A COMPLETE LIST OF APPLICABLE NFPA STANDARDS REFER TO 2016 CBC (SFM) CHAPTER 35 AND CALIFORNIA FIRE CODE CHAPTER 80.

SEE CALIFORNIA BUILDING CODE, CHAPTER 35, FOR STATE OF CALIFORNIA AMENDMENTS TO THE NFPA STANDARDS.

AMERICANS WITH DISABILITIES ACT TITLE II, REGULATIONS 28 CFR PART 35, 2010 ADA STANDARDS FOR ACCESSIBLE DESIGN

2018 CITY OF SAN DIEGO STANDARD DRAWINGS FOR PUBLIC WORKS CONSTRUCTION

*ALL PARTS OF THE 2016 CALIFORNIA BUILDING CODE BECOME EFFECTIVE JANUARY 1, 2017 EXCEPT THE EFFECTIVE DATE FOR THE USE OF THE 2016 BUILDING ENERGY EFFICIENCY STANDARDS (TITLE 24, PART 1, CHAPTER 10) IS FEBRUARY 25, 2016 AND THE EFFECTIVE DATE FOR THE USE OF THE CALIFORNIA ADMINISTRATIVE CODE (TITLE 24, PART 1, CHAPTER 24) IS JANUARY 20, 2016.

SHEET LIST, SCOPE, SITE PLAN REFERENCES

SHEET LIST:	REFER TO SHEET G-2	(SET SHEET No. 3-D)
SCOPE OF WORK/ WORK TO BE DONE:	REFER TO SHEET G-1	(SET SHEET No. 2-D)
SITE PLAN	REFER TO SHEET G-7	(SET SHEET No. 8-D)
DEFERRED SUBMITTALS:	NONE	

FIRE ALARM EXEMPTION NOTE

THIS PROJECT IS EXEMPT FROM THE GREEN OAKS FAMILY ACADEMY ELEMENTARY SCHOOL FIRE PROTECTION ACT (SB 575, CHAPTER 725, STATUTES OF 2001), A LETTER FROM DAVID KOEPPCKE (DISTRICT ARCHITECT) TO CRAIG RUSH (REGIONAL MANAGER, DIVISION OF THE STATE ARCHITECT) DATED APRIL 11, 2019, IS ON FILE WITH DSA CONFIRMING THE EXEMPTION.

CONCESSIONS ROOM NOTE

THE CONCESSIONS ROOM/FACILITY WILL BE 100% PRE-PACKAGED FOOD ONLY.

DISTRICT'S UNIQUE BUILDING IDENTIFIER

THIS BUILDING WILL BE IDENTIFIED AS "04-11" IN THE WANGENHEIM MIDDLE SCHOOL CAMPUS.

BUILDING DATA

PROPOSED USE:	RESTROOM/STORAGE/CONCESSIONS
OCCUPANCY GROUP:	B
CONSTRUCTION TYPE:	V-B
STORIES, ALLOWED:	2
STORIES, ACTUAL:	1
BUILDING HEIGHT, ALLOWED:	40 FEET
BUILDING HEIGHT, ACTUAL:	15'-1"
AREA PER FLOOR, ALLOWED:	9,000 SF
AREA PER FLOOR, ACTUAL:	2,385 GSF
OCCUPANTS, DESIGN LOAD:	5
FIRE SUPPRESSION SYSTEM:	NO
PORTABLE FIRE EXTINGUISHERS:	YES
FIRE RESISTANCE RATING FOR BUILDING ELEMENTS:	
STRUCTURAL FRAME:	0
BEARING WALLS:	0
NON-BEARING WALLS, INTERIOR:	0
FLOOR CONSTRUCTION:	0
ROOF CONSTRUCTION:	0
SHAFT ENCLOSURES:	N/A
STAIRWAY ENCLOSURES:	N/A
CORRIDOR:	N/A
FIRE RESISTANCE RATING REQUIREMENTS FOR EXTERIOR WALLS BASED ON FIRE SEPARATION DISTANCE:	
X > 5 FEET	1 HR
5 ≤ X < 10 FEET	1 HR
10 ≤ X < 30 FEET	0 HR
X ≥ 30 FEET	0 HR

STATEMENT OF GENERAL CONFORMANCE

FOR ARCHITECTS/ENGINEERS WHO UTILIZE PLANS, INCLUDING BUT NOT LIMITED TO SHOP DRAWINGS, PREPARED BY OTHER LICENSED DESIGN PROFESSIONALS AND/OR CONSULTANTS.

(APPLICATION NO. 04-118244 FILE NO. 33-59)

THE DRAWINGS OR SHEETS LISTED ON SHEET G-2 THIS DRAWING, PAGE OF SPECIFICATIONS/CALCULATIONS

HAVE BEEN PREPARED BY OTHER DESIGN PROFESSIONALS OR CONSULTANTS WHO ARE LICENSED AND/OR AUTHORIZED TO PREPARE SUCH DRAWINGS IN THE STATE. IT HAS BEEN EXAMINED BY ME FOR:

- DESIGN INTENT AND APPEARS TO MEET THE APPROPRIATE REQUIREMENTS OF TITLE 24, CALIFORNIA CODE OF REGULATIONS AND THE PROJECT SPECIFICATIONS PREPARED BY ME, AND
- COORDINATION WITH MY PLANS AND SPECIFICATIONS AND IS ACCEPTABLE FOR INCORPORATION INTO THE CONSTRUCTION OF THIS PROJECT.

THE STATEMENT OF GENERAL CONFORMANCE "SHALL NOT BE CONSTRUED AS RELIEVING ME OF MY RIGHTS, DUTIES AND RESPONSIBILITIES UNDER SECTIONS 17306 AND 81138 OF THE EDUCATION CODE AND SECTIONS 4-336, 4-431 AND 4-344" OF TITLE 24, PART 1. (TITLE 24, PART 1, SECTION 4-317 [b])

I CERTIFY THAT:

ALL CIVIL, LANDSCAPE, STRUCTURAL, MECHANICAL, PLUMBING, ELECTRICAL AND SHADE STRUCTURE SHEETS.

IS/ARE IN GENERAL CONFORMANCE AND HAVE BEEN COORDINATED

_____/7/18/2019
 SIGNATURE DATE

ARCHITECT OR ENGINEER DESIGNATED TO BE IN GENERAL RESPONSIBLE CHARGE.

J. MANUEL ONCINA
 PRINT NAME

C 13996 2/28/2021
 LICENSE NUMBER RENEWAL DATE

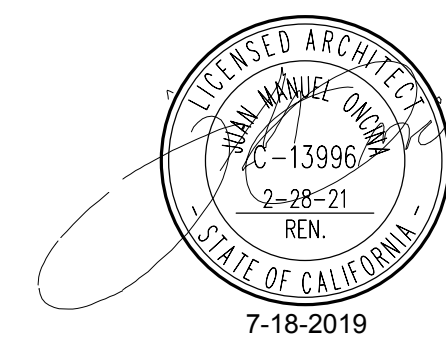

MANUEL ONCINA ARCHITECTS INC. ARCHITECTURE PLANNING INTERIORS
 5711 La Jolla Blvd
 La Jolla, CA 92037
 tel 858/459.1221
 fax 858/459.1214
 www.oncinarc.com

OWNER/APPLICANT

ARCHITECT:
 CITY OF SAN DIEGO
 PUBLIC WORKS / ENGINEERING AND CAPITAL PROJECTS DEPARTMENT
 YOVANNA LEWIS
 525 B STREET, SUITE 750
 SAN DIEGO, CA 92101
 T: (619) 533-5130

PROJECT TEAM

ARCHITECT:
 MANUEL ONCINA ARCHITECTS, INC.
 5711 LA JOLLA BLVD.
 LA JOLLA, CA 92037
 T: (858) 459-1221
 F: (858) 459-1214
 CONTACT: PATRICK BANNING
 PBANNING@ONCINAARC.COM

STRUCTURAL ENGINEER:
 ORION STRUCTURAL ENGINEERING, INC.
 11305 RANCHO BERNARDO RD. SUITE 121
 SAN DIEGO, CA 92127
 T: (858) 679-1974
 F: (858) 679-1975
 CONTACT: RYAN OMER
 RYAN@ORIONSE.COM

MECHANICAL ENGINEER:
 T-SQUARED PROFESSIONAL ENGINEERS, INC.
 1340 SPECIALTY DR. SUITE E
 VISTA, CA 92081
 T: (760) 560-0100
 F: (760) 560-0101
 CONTACT: GRACE ZEELIG
 GRACE.ZEELIG@SALASOBRIEN.COM

ELECTRICAL ENGINEER:
 T-SQUARED PROFESSIONAL ENGINEERS, INC.
 1340 SPECIALTY DR. SUITE E
 VISTA, CA 92081
 T: (760) 560-0100
 F: (760) 560-0101
 CONTACT: GRACE ZEELIG
 GRACE.ZEELIG@SALASOBRIEN.COM

PLUMBING ENGINEER:
 T-SQUARED PROFESSIONAL ENGINEERS, INC.
 1340 SPECIALTY DR. SUITE E
 VISTA, CA 92081
 T: (760) 560-0100
 F: (760) 560-0101
 CONTACT: GRACE ZEELIG
 GRACE.ZEELIG@SALASOBRIEN.COM

CIVIL ENGINEER:
 RICK ENGINEERING COMPANY
 5620 FRIARS RD.
 SAN DIEGO, CA 92110
 T: (619) 291-0707
 F: (619) 291-4165
 CONTACT: KAREN VAN ERT, P.E.
 KVANERT@RICKENGINEERING.COM

LANDSCAPE:
 RICK ENGINEERING COMPANY
 5620 FRIARS RD.
 SAN DIEGO, CA 92110
 T: (619) 291-0707
 F: (619) 291-4165
 CONTACT: TIMOTHY PRUSS, ASLA
 TPRUSS@RICKENGINEERING.COM

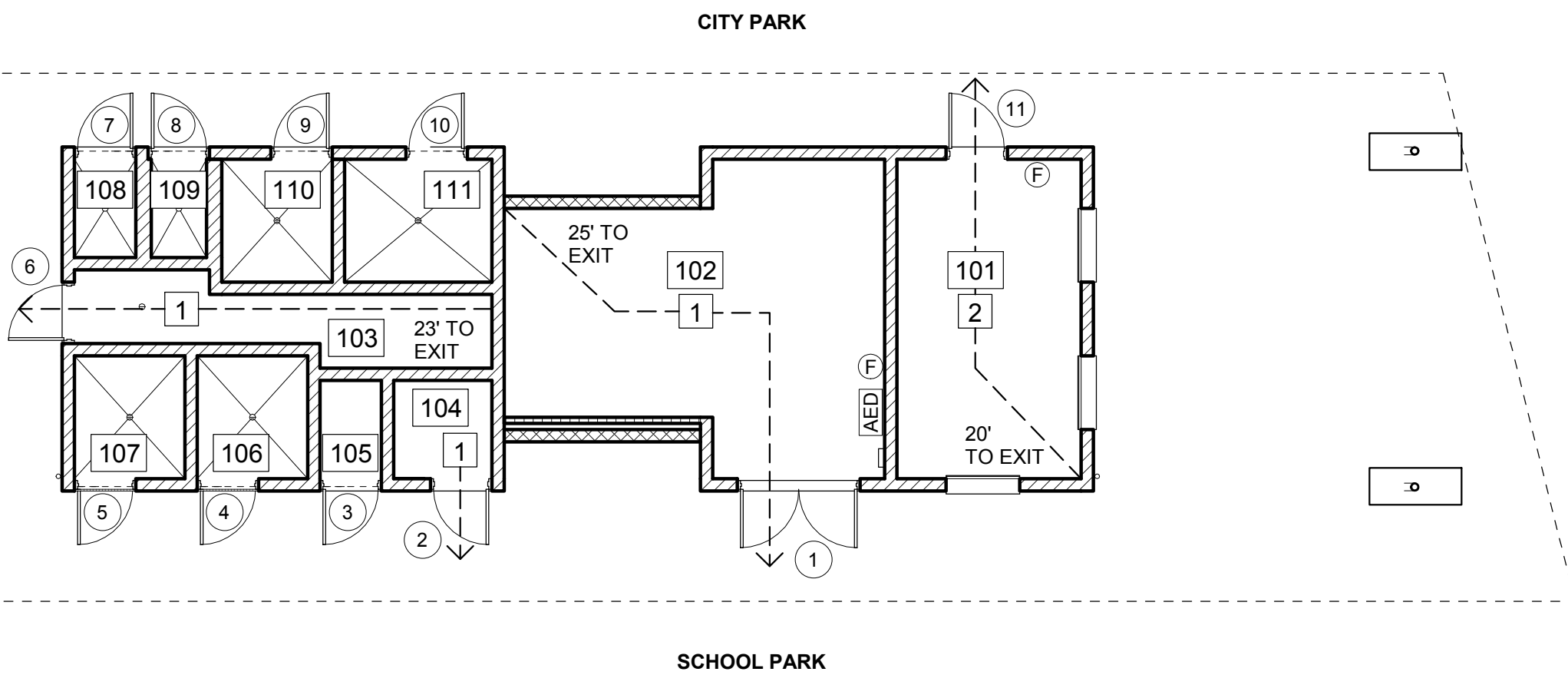

EGRESS DIAGRAM 1
 1/8" = 1'-0"

SYMBOL LEGEND

- # ROOM OCCUPANT LOAD
- # EXIT OPENING
- # ACCUMULATED EXITING LOAD
- F FIRE EXTINGUISHER CLASS 4A-20B.C
- INTENDED EGRESS ROUTE
- AED AED DEVICE IN CABINET
- ←--- EXIT

ROOM EXITING ANALYSIS

#	ROOM NAME	AREA	LOAD FACTOR	OCCUPANT LOAD	# OF REQUIRED EXITS	EXIT WIDTH FACTOR (INCHES)	EXIT WIDTH REQUIRED (INCHES)
101	CONCESSION ROOM	173 SF	100 GROSS	2	1	0.2	0.4
102	STORAGE ROOM	290 SF	300 GROSS	1	1	0.2	0.2
103	PLUMBING CHASE	83 SF	300 GROSS	1	1	0.2	0.2
104	ELECTRICAL ROOM	28 SF	300 GROSS	1	1	0.2	0.2

EXIT SCHEDULE

Door #	EXITING ROOM	EXITING LOAD	EXIT WIDTH FACTOR (INCHES)	EXIT WIDTH REQUIRED (INCHES)	EXIT WIDTH PROVIDED (INCHES)	REMARKS
1	STORAGE ROOM	2	0.2	0.4	36	
2	ELECTRICAL ROOM	1	0.2	0.2	36	
6	PLUMBING CHASE	1	0.2	0.2	36	
11	CONCESSION ROOM	1	0.2	0.2	36	

CONSTRUCTION CHANGE / ADDENDUM			
CHANGE	DATE	AFFECTED OR ADDED SHEET NUMBERS	APPROVAL NO.
B	1/12/2021	2,10-14,16,17,22-26,28,33-37,39,41,43,46-50,75-77,79-81,85,100,104,108,113,117,118,130-133,137	

WARNING
 0 1
 IF THIS BAR DOES NOT MEASURE 1" THEN DRAWING IS NOT TO SCALE.



AS-BUILT INFORMATION	
MATERIALS	MANUFACTURER
-	-
-	-
-	-
-	-
-	-
-	-
-	-
-	-
-	-
-	-

APPROVED: _____ 10/13/2020
 FOR CITY ENGINEER DATE
 JASON GRANI 77208
 PRINT NAME RCE#

REGISTERED PROFESSIONAL ARCHITECT NO. C77208 STATE OF CALIFORNIA

WANGENHEIM NEIGHBORHOOD JOINT USE FACILITY ARCHITECTURAL TITLE SHEET

CITY OF SAN DIEGO, CALIFORNIA PUBLIC WORKS DEPARTMENT SHEET 1 OF 142 SHEETS		WBS S-15007
APPROVED: _____ 10/13/2020 FOR CITY ENGINEER DATE JASON GRANI 77208 PRINT NAME RCE#	SUBMITTED BY: YOVANNA LEWIS PROJECT MANAGER	CHECKED BY: MEHDI RASHIDPOUR-HARISI PROJECT ENGINEER
DESCRIPTION BY APPROVED DATE FILMED	270-1731 (NAD27)	1910-6291 (NAD83)
ORIGINAL REC ADDENDUM B REC	1/11/2021	CCS27 COORDINATE CCS83 COORDINATE
CONTRACTOR INSPECTOR	DATE STARTED DATE COMPLETED	40846-1 -D

WANGENHEIM NEIGHBORHOOD JOINT USE FACILITY

IDENTIFICATION STAMP
 DIV. OF THE STATE ARCHITECT
 APP. 04-118244 INC.
 REVIEWED FOR
 SS FLS ACS
 DATE: 02.14.2020

CONTRACTOR'S NOTES

- PURSUANT TO SECTION 4216 OF THE GOVERNMENT CODE, AT LEAST 2 WORKING DAYS PRIOR TO EXCAVATION, YOU MUST CONTACT THE REGIONAL NOTIFICATION CENTER, (E.G. UNDERGROUND SERVICE ALERT OF SOUTHERN CALIFORNIA) AND OBTAIN AN INQUIRY IDENTIFICATION NUMBER.
- THE APPROVAL OF THIS PLAN OR ISSUANCE OF A PERMIT BY THE CITY OF SAN DIEGO DOES NOT AUTHORIZE THE UTILITY COMPANY TO VIOLATE ANY FEDERAL, STATE OR CITY LAWS, ORDINANCES, REGULATIONS, OR POLICIES.
- IMPORTANT NOTICE: SECTION 4216 OF THE GOVERNMENT CODE REQUIRES A DIG ALERT IDENTIFICATION NUMBER ISSUED BEFORE A "PERMIT TO EXCAVATE" WILL BE VALID. FOR YOUR DIG ALERT I.D. NUMBER, CALL UNDERGROUND SERVICE ALERT, TOLL FREE (800) 422-4133, TWO DAYS BEFORE YOU DIG.
- DEVIATIONS FROM THESE SIGNED PLANS WILL NOT BE ALLOWED UNLESS A CONSTRUCTION CHANGE IS APPROVED BY THE CITY ENGINEER OR THE CHANGE IS REQUIRED BY THE RESIDENT ENGINEER.
- CONTRACTOR SHALL REPLACE OR REPAIR ALL TRAFFIC SIGNAL LOOPS, CONDUITS, AND LANE STRIPPING DAMAGED DURING CONSTRUCTION.
- CONTRACTOR IS RESPONSIBLE FOR THE COST OF REPLACING ALL SURVEY MONUMENTS WHICH ARE DAMAGED OR DESTROYED BY CONSTRUCTION.
- PRIOR TO CONSTRUCTION, SURVEY MONUMENTS THAT ARE LOCATED IN THE CONSTRUCTION AREA SHALL BE TIED-OUT AND REFERENCED BY A LAND SURVEYOR.
- CONTRACTOR SHALL IMPLEMENT AN EROSION CONTROL PROGRAM DURING THE PROJECT CONSTRUCTION ACTIVITIES. THE PROGRAM SHALL COMPLY WITH ALL APPLICABLE REQUIREMENTS OF THE STATE WATER RESOURCE CONTROL BOARD.

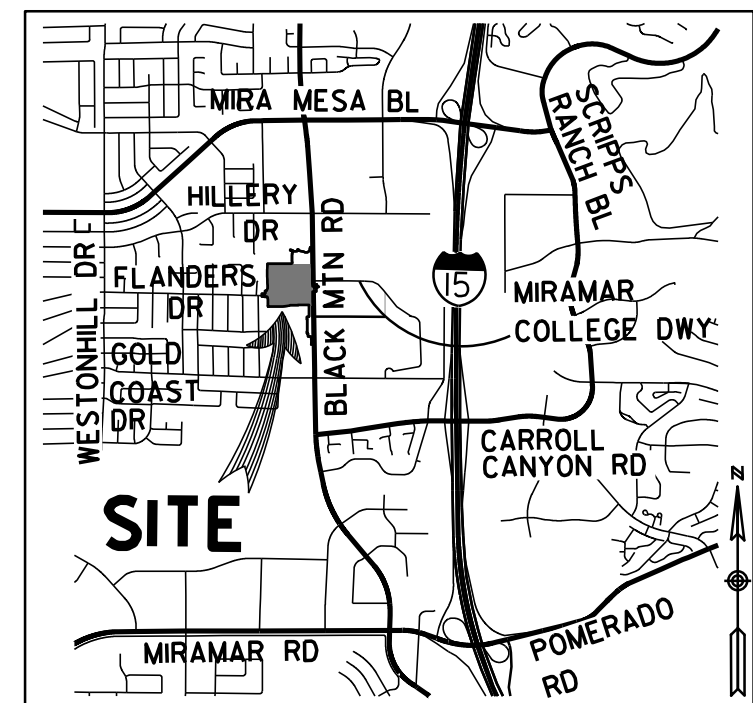

OWNER/APPLICANT

PUBLIC WORKS DEPARTMENT
 526 B STREET, SUITE 750
 SAN DIEGO, CA 92101

SOURCE OF TOPOGRAPHY

FIELD SURVEYS PREPARED BY
 RICK ENGINEERING COMPANY
 DATED 11/22/2016, 11/29/16,
 11/30/16, 6/4/18, 6/6/18

SITE ADDRESS

WANGENHEIM MIDDLE SCHOOL
 9230 GOLD COAST DR.
 SAN DIEGO, CA. 92126

LEGAL DESCRIPTION

PORTION OF THE SOUTHEAST
 QUARTER OF SECTION 31,
 TOWNSHIP 14 SOUTH, RANGE 2 WEST,
 IN THE COUNTY OF SAN DIEGO,
 STATE OF CALIFORNIA, ACCORDING
 TO THE OFFICIAL PLAT THEREOF.

SHEET INDEX/LIMITS OF WORK

SEE SHEET G-2 FOR INDEX

MONUMENT/SURVEY NOTES

SEE SHEET G-2 FOR NOTES

ASSESSORS PARCEL NUMBER

318-120-02

REFERENCE DRAWINGS

18223-2 TRU 8-D STORM DRAIN/IRRIGATION
 27941-21-D UTILITES
 15712-2-D FLANDERS DRIVE
 MUNITIONS RESPONSE PLAN:
 ENSAFE (DATED JUNE 8,2018)

BENCHMARK

THE BENCH MARK FOR THIS SURVEY IS THE NWBP
 BLACK MOUNTAIN RD. & HILLERY DR., PER
 CITY OF SAN DIEGO VERTICAL CONTROL BOOK
 DATED OCTOBER 4, 2011.

ELEVATION: 493.481, MSL NGVD DATUM

BASIS OF BEARING/COORDINATES

THE BASIS OF BEARINGS AND COORDINATES FOR
 THIS SURVEY IS THE CALIFORNIA COORDINATE SYSTEM
 OF 1983 (CCS83) ZONE 6, NAD83, BASED UPON THE
 GRID BEARING BETWEEN STATIONS 652 AND 627,
 BOTH STATIONS PER RECORD OF SURVEY 14492.

BEARING STATION 652 TO 627: N0° 56'53"W

TOTAL DISTURBED AREA

11.6 ACRES

EARTHWORK QUANTITIES

IMPORT: 900 CY (NON-STABILIZED DG)
 IMPORT: 500 CY (STABILIZED DG)
 IMPORT: 3,100 CY (FILL SOIL)
 EXPORT: 1,5500 CY (TURF - 2' GRASS SECTION)

DISCIPLINE CODE

AT- ARCHITECTURAL TITLE	S- STRUCTURAL
G- GENERAL	M- MECHANICAL
D- DEMOLITION	P- PLUMBING
C- CIVIL	E- ELECTRICAL
L- LANDSCAPE	T- TRAFFIC
A- ARCHITECTURAL	

BC BEGIN CURVE	FH FIRE HYDRANT
BF BOTTOM OF FOOTING	FL FLOW LINE
BLDG BUILDING	FT FOOT OR FEET
BM BENCH MARK	G GAS
BO BLOW OFF VALVE	GB GRADE BREAK
BW BOTTOM OF WALL	HP HIGH POINT
CL CENTER LINE	IE INVERT ELEVATION
CMU CONCRETE MASONRY UNIT	LP LOW POINT
CO CLEANOUT	MAX. MAXIMUM
EL. OR ELEV. ELEVATION	MIN. MINIMUM
E OR ELEC. ELECTRIC, ELECTRICAL	NTS NOT TO SCALE
EX. OR EXIST. EXISTING	PA PLANTER AREA
FF FINISHED FLOOR	POC POINT OF CONNECTION
FG FINISHED GRADE	PIV POST INDICATOR VALVE
FS FINISHED SURFACE	PCC PORTLAND CEMENT CONCRETE
FS FIRE SERVICE	PUB PUBLIC
	PVT PRIVATE

ABBREVIATIONS

R RADIUS
RCP REINFORCED CONCRETE PIPE
RW RECLAIMED WATER
RD ROOF DRAIN
RIM RIM ELEVATION
SD STORM DRAIN
S SANITARY SEWER
STA STATION
TC TOP OF CURB
TB TOP OF BOX
TF TOP OF FOOTING
TG TOP OF GRATE
TP TOP OF PIPE
TW TOP OF WALL
TYP TYPICAL
W WATER

GRADING & GEOTECHNICAL SPECIFICATIONS

1. ALL GRADING SHALL BE DONE UNDER OBSERVATION AND TESTING BY A QUALIFIED CIVIL ENGINEER OR GEOTECHNICAL ENGINEER AND, IF REQUIRED, BOTH A QUALIFIED CIVIL ENGINEER OR GEOTECHNICAL ENGINEER AND AN ENGINEERING GEOLOGIST. ALL GRADING MUST BE PERFORMED IN ACCORDANCE WITH APPLICABLE CITY ORDINANCE AND THE RECOMMENDATIONS AND SPECIFICATIONS SET FORTH IN THE SOILS REPORT OR GEOLOGICAL/GEOTECHNICAL INVESTIGATION ENTITLED

- GEOTECHNICAL INVESTIGATION, WANGENHEIM NEIGHBORHOOD JOINT USE FACILITY, PREPARED BY ALLIED GEOTECHNICAL ENGINEERS, INC. FEBRUARY 07, 2017 WBS* S-15007
- GEOTECHNICAL INVESTIGATION UPDATE LETTER, WANGENHEIM NEIGHBORHOOD JOINT USE FACILITY, PREPARED BY ALLIED GEOTECHNICAL ENGINEERS, INC. APRIL 24, 2019 (UPDATED) WBS* S-15007

2. ALL FILL MATERIAL SHALL BE COMPACTED TO A MINIMUM OF 90% THE MAXIMUM DRY DENSITY AS DETERMINED BY THE MOST RECENT VERSION OF A.S.T.M. D-1557 OR AN APPROVED ALTERNATIVE STANDARD.

3. AT THE COMPLETION OF THE GRADING OPERATIONS FOR THE EARTHWORK SHOWN ON THIS PLAN, AN AS-GRADED SOILS REPORT, OR IF REQUIRED, AN AS-GRADED GEOTECHNICAL REPORT WILL BE PREPARED IN ACCORDANCE WITH THE MOST RECENT EDITION OF THE CITY OF SAN DIEGO TECHNICAL GUIDELINES FOR GEOTECHNICAL REPORTS. THE FINAL "AS-GRADED" GEOTECHNICAL REPORT WILL BE SUBMITTED TO THE FIELD ENGINEERING SECTION OF ENGINEERING AND CAPITAL PROJECTS DEPARTMENT AND A SECOND COPY TO THE GEOLOGY SECTION OF THE DEVELOPMENT SERVICES DEPARTMENT WITHIN 30 DAYS OF THE COMPLETION OF GRADING. WHERE GEOLOGIC INSPECTION IS INDICATED IN THE PERMIT OR PROJECT PLANS, REPORTS OR SPECIFICATIONS, THE FINAL REPORT MUST ALSO BE REVIEWED AND SIGNED BY A CALIFORNIA CERTIFIED ENGINEERING GEOLOGIST.

4. IF THE GEOTECHNICAL CONSULTANT OF RECORD IS CHANGED FOR THE PROJECT, THE WORK SHALL BE STOPPED UNTIL THE REPLACEMENT HAS AGREED IN WRITING TO ACCEPT THE RESPONSIBILITY WITHIN THE AREA OF THEIR TECHNICAL COMPETENCE FOR APPROVAL UPON COMPLETION OF THE WORK. IT SHALL BE THE DUTY OF THE PERMITTEE TO NOTIFY THE CITY ENGINEER AND THE GEOLOGY SECTION OF DEVELOPMENT SERVICES IN WRITING OF SUCH CHANGE PRIOR TO THE RECOMMENCEMENT OF GRADING.

5. THESE GRADING PLANS HAVE BEEN REVIEWED BY THE UNDERSIGNED AND FOUND TO BE IN CONFORMANCE WITH THE RECOMMENDATIONS AND SPECIFICATIONS CONTAINED IN THE REFERENCED GEOTECHNICAL REPORT(S) PREPARED FOR THIS PROJECT.

GRADING NOTES

1. GRADING AS SHOWN ON THESE PLANS SHALL BE IN CONFORMANCE WITH CURRENT STANDARD SPECIFICATIONS AND CHAPTER 14, ARTICLE 2, DIVISION 1, OF THE SAN DIEGO MUNICIPAL CODE.

2. PLANT AND IRRIGATE ALL CUT AND FILL SLOPES AS REQUIRED BY ARTICLE 2, DIVISION 4, SECTION 142.0411 OF THE SAN DIEGO LAND DEVELOPMENT CODE AND ACCORDING TO SECTION IV OR THE LAND DEVELOPMENT MANUAL LANDSCAPE STANDARDS.

3. GRADED, DISTURBED, OR ERODED AREAS THAT WILL NOT BE PERMANENTLY PAVED, COVERED BY STRUCTURE, OR PLANTED FOR A PERIOD OVER 90 DAYS SHALL BE TEMPORARILY RE-VEGETATED WITH A NON-IRRIGATED HYDROSEED MIX, GROUND COVER, OR EQUIVALENT MATERIAL PER CITY GRADING PLANS.

CONSTRUCTION AND DEMOLITION NOTES

COMPLIANCE WITH CFC CHAPTER 33 FIRE SAFETY OF THE CALIFORNIA BUILDING STANDARDS MUST BE FOLLOWED DURING CONSTRUCTION AND DEMOLITION PHASES OF THE ENTIRE PROJECT.

DECLARATION OF RESPONSIBLE CHARGE

I HEREBY DECLARE THAT I AM THE ENGINEER OF WORK FOR THIS PROJECT THAT I HAVE EXERCISED RESPONSIBLE CHARGE OVER THE DESIGN OF THE PROJECT AS DEFINED IN SECTION 6703 OF THE BUSINESS AND PROFESSIONS CODE AND THAT THE DESIGN IS CONSISTENT WITH CURRENT STANDARDS. I UNDERSTAND THAT THE CHECK OF PROJECT DRAWINGS AND SPECIFICATIONS BY THE CITY OF SAN DIEGO IS CONFINED TO A REVIEW ONLY AND DOES NOT RELIEVE ME, AS ENGINEER OF WORK, OF MY RESPONSIBILITIES FOR PROJECT DESIGN.

Karen S. Van Ert
 KAREN S. VAN ERT R.C.E. 56991 EXP. 6-30-2021 10/15/2019 DATE



Sani Sutanto
 SANISUTANTO C. 51873 EXP.: 06/30/2022
 REGISTERED PROFESSIONAL ENGINEER
 No. 51873
 Exp. 06/30/2022
 CIVIL
 STATE OF CALIFORNIA

Nicholas E. Barnes
 NICHOLAS E. BARNES C.E.G.: 1693 EXP.: 05/31/2022
 REGISTERED PROFESSIONAL ENGINEER
 No. 1693
 Exp. 05/31/2022
 CIVIL
 STATE OF CALIFORNIA

ALLIED GEOTECHNICAL ENGINEERS, INC
 9500 CUYAMACA STREET, SUITE 102
 SANTEE, CA 92071-2685
 (619) 449-5900

CONTRACTOR RESPONSIBILITIES

- PURSUANT TO SECTION 4216 OF THE CALIFORNIA GOVERNMENT CODE, AT LEAST WORKING DAYS PRIOR TO EXCAVATION, YOU MUST CONTACT THE REGIONAL NOTIFICATION CENTER (E.G. UNDERGROUND SERVICE ALERT OF SOUTHERN CALIFORNIA) AND OBTAIN AN INQUIRY IDENTIFICATION NUMBER.
- NOTIFY SDG&E AT LEAST 10 WORKING DAYS PRIOR TO EXCAVATION WITHIN 10' OR SDG&E UNDERGROUND HIGH VOLTAGE TRANSMISSION POWER LINES (I.E., 69 KV OR HIGHER)
- FUDS SITE: POTENTIAL UNEXPLODED ORDNANCE (UXO) ON SITE. PLEASE CONTACT FPC-CEQA/ENVIRONMENTAL GROUP, PAUL GARCIZ, PGARCIA4@SANDI.NET, BEFORE DIGGING.

STREET EXCAVATION TABLE

STREET NAME	INTERSECTING STREETS	STREET CLASSIFICATION (ARTERIAL, MAJOR, COLLECTOR, RESIDENTIAL)	UTILITY TYPE (WET OR DRY)	LATERAL OR MAIN	LAST STREET OVERLAY DATE	INFLUENCE AREA WIDTH (FT) PER SDMC 62.120	TRENCH WIDTH (FT)	TRENCH LENGTH (FT)	STREET MORATORIUM (Y/N)
BLACK MOUNTAIN ROAD	HILLERY DRIVE (PUBLIC) GOLD COAST DRIVE (PUBLIC)	ARTERIAL	WTR (WET)	LATERAL	5/21/1998	3.0'	3.0'	3.0'	N

RICK ENGINEERING COMPANY
 5620 FRIARS ROAD
 SAN DIEGO, CA 92110
 619-291-0707
 (FAX) 619-291-4165
 rickengineering.com
 San Diego Riverside - Orange - Sacramento - San Luis Obispo - Phoenix - Tucson - Denver

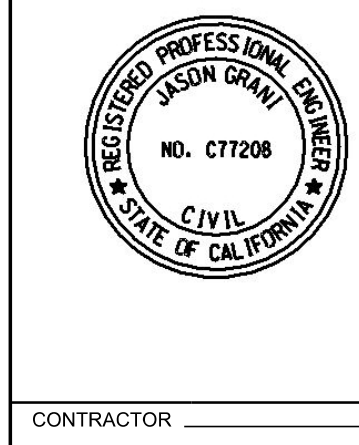

WANGENHEIM NEIGHBORHOOD JOINT USE FACILITY
CIVIL TITLE SHEET

CITY OF SAN DIEGO, CALIFORNIA
 PUBLIC WORKS DEPARTMENT
 SHEET 2 OF 142 SHEETS

APPROVED: *Jason Grani* 10/13/2020 DATE
 FOR CITY ENGINEER JASON GRANI DATE 77208
 PRINT NAME RCE#

SUBMITTED BY: YOVANNA LEWIS PROJECT MANAGER
 CHECKED BY: MEHDI RASHIDPOUR-HARISH PROJECT ENGINEER

DESCRIPTION	BY	APPROVED	DATE	FILMED
ORIGINAL	REC			
ADDENDUM B	REC	<i>Jason Grani</i>	1/11/2021	

CONTRACTOR INSPECTOR: _____ DATE STARTED: _____ DATE COMPLETED: _____

40846- 2-D

ADDENDUM B

ADDED SIGNATURES AND REVISED EARTHWORK QUANTITIES

ADDENDUM B

IDENTIFICATION STAMP
 DIV. OF THE STATE ARCHITECT
 APP. 04-118244 INC.
 REVIEWED FOR
 SS FLS ACS
 DATE: 02.14.2020

- EXISTING CONDITIONS & DEMOLITION NOTES:**
- 1 REMOVE EXISTING CONCRETE PAD
 - 2 REMOVE EXISTING BACKSTOPS TO BE SALVAGED AND RELOCATED PER LANDSCAPE PLANS SHEETS L-1 THRU L-5
 - 3 REMOVE & SALVAGE EXISTING LIGHTING, TO BE REUSED PER ELECTRICAL PLANS. TURN OVER TO CITY PARKS & REC DURING DEMOLITION.
 - 4 REMOVE EXISTING CONCRETE FOOTING
 - 5 EXISTING SEWER CLEANOUT TO REMAIN AND PROTECT IN PLACE. BURY TO PROPOSED FINISH GRADE PER ROUGH GRADING PLANS.
 - 6 EXISTING LATERAL AND MAIN IRRIGATION LINES ARE TO BE ABANDONED IN PLACE. ANY PIPING EXPOSED DURING CONSTRUCTION WORK SHALL BE REMOVED TO A DEPTH OF 12" BELOW FINISH SURFACE. SEE AS-BUILT DRAWINGS 18223-D FOR EXISTING LOCATION. ALL VALVES, MANIFOLDS, SPRINKLER HEADS AND SWING JOINTS ARE TO BE REMOVED AND TURNED OVER TO THE CITY OF SAN DIEGO.
 - 7 EXISTING TRANSFORMER TO REMAIN AND PROTECT IN PLACE
 - 8 REMOVE AND RELOCATE EXISTING DRAINAGE STRUCTURE AND GRATE.
 - 9 REMOVE EXISTING WATER VALVE AND CONCRETE VALVE BOX. CAP SERVICE LINE BELOW GRADE AND ABANDON IN PLACE.
 - 10 EXISTING TREE TO PROTECT IN PLACE
 - 11 EXISTING ELECTRICAL TRANSFORMERS TO BE RELOCATED. SEE ELECTRICAL PLANS.
 - 12 ADJUST TO FINISH GRADE EXISTING CORROSION TEST STATION
 - 13 ADJUST TO FINISH GRADE EXISTING TELEPHONE VAULT. CONTRACTOR TO COORDINATE WITH TELEPHONE COMPANY.
 - 14 ADJUST TO FINISH GRADE EXISTING TRAFFIC PULL BOX
 - 15 ADJUST TO FINISH GRADE EXISTING ELECTRIC PULL BOX
 - 16 ADJUST TO FINISH GRADE EXISTING AIR RELEASE VALVE
 - 17 ADJUST TO FINISH GRADE EXISTING BUS, TRAFFIC AND PEDESTRIAN CROSSING SIGN
 - 18 ADJUST TO FINISH GRADE EXISTING BUS STOP BENCHES
 - 19 EXISTING ELECTRICAL TRANSFORMER TO REMAIN AND PROTECT IN PLACE
 - 20 RELOCATE EXISTING IRRIGATION SEE LANDSCAPE PLANS
 - 21 EXISTING WATER VALVE TO BE REMOVED AND LINE CAPPED
 - 22 EXISTING SDG&E MANHOLE TO REMAIN AND PROTECT IN PLACE
 - 23 PROTECT EXISTING CURB & GUTTER
 - 24 EXISTING STORM DRAIN GRATE TO REMAIN AND PROTECT IN PLACE
 - 25 PROTECT EXISTING STREET LIGHT IN PLACE
 - 26 EXISTING TRAFFIC SIGNS TO REMAIN AND PROTECT IN PLACE
 - 27 ADJUST TO FINISH GRADE EXISTING COX MANHOLE. CONTRACTOR TO COORDINATE WITH COX COMMUNICATIONS.
 - 28 EXISTING CATHODIC PROTECTION AND SDG&E MANHOLE TO REMAIN AND PROTECT IN PLACE
 - 30 EXISTING CONCRETE SLOPE TO REMAIN AND PROTECT IN PLACE
 - 31 EXISTING CONCRETE PAD TO REMAIN AND PROTECT IN PLACE
 - 32 REMOVE EXISTING CURB RAMP
 - 33 REMOVE EXISTING FENCE TO PROPOSED PATHWAY AND ADD TERMINUS POST
 - 34 EXISTING CONCRETE SLOPE TO BE REMOVED
 - 35 EXISTING RUBBER PAD TO PROTECT IN PLACE
 - 36 EXISTING MOW CURB TO REMAIN AND PROTECT IN PLACE
 - 37 REMOVE EXISTING FIELD GUARD POSTS
 - 38 EXISTING SEWER MANHOLE TO REMAIN AND PROTECT IN PLACE
 - 39 REMOVE EXIST. DRAIN GRATE. TOP OF STRUCTURE TO BE BURIED 2' BELOW PROPOSED FINISH GRADE PER ROUGH GRADING PLANS. SEE DETAIL SHEET G-4.
 - 40 EXISTING IRRIGATION TO ADJUST TO FINISH GRADE
 - 41 EXISTING FENCE TO REMAIN AND PROTECT IN PLACE
 - 42 EXISTING BLEACHERS TO BE REMOVED AND TURNED OVER TO CITY PARKS AND RECREATION OR CITY RESIDENT ENGINEER
 - 46 REMOVE PORTIONS OF EXISTING FENCE. SEE LANDSCAPE PLANS, SHEETS L-1 THRU L-5 FOR PROPOSED FENCING

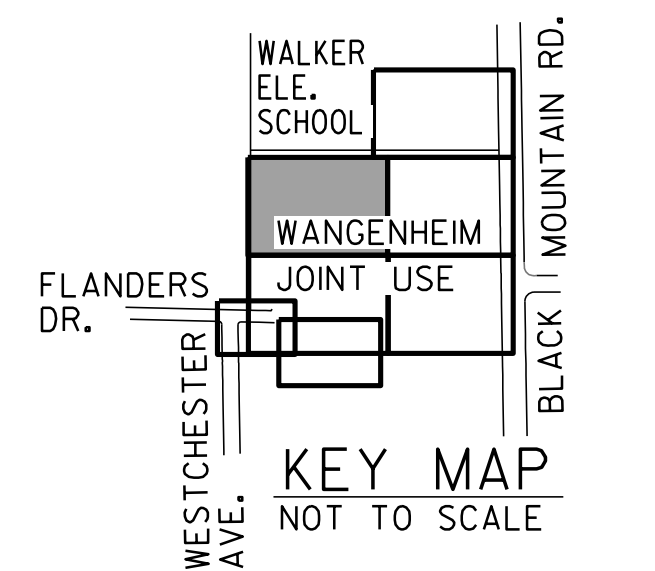

IMPORTANT NOTICE
 SECTION 4215/4217 OF THE GOVERNMENT CODE REQUIRES A DIG ALERT IDENTIFICATION NUMBER BE ISSUED BEFORE A 'PERMIT TO EXCAVATE' WILL BE VALID. FOR YOUR DIG ALERT I.D. NUMBER, CALL UNDERGROUND SERVICE ALERT TOLL FREE 1-800-422-4133 AT LEAST TWO WORKING DAYS BEFORE YOU DIG.

**WANGENHEIM NEIGHBORHOOD JOINT USE FACILITY
 DEMOLITION PLAN**

CITY OF SAN DIEGO, CALIFORNIA PUBLIC WORKS DEPARTMENT SHEET 10 OF 142 SHEETS		WBS S-15007
APPROVED: JASON GRANI FOR CITY ENGINEER PRINT NAME	DATE: 10/13/2020 77208 RCE#	SUBMITTED BY: YOVANNA LEWIS PROJECT MANAGER CREATED BY: MEHDI RASHIDPOUR-HARISI PROJECT ENGINEER
DESCRIPTION	BY	APPROVED
ORIGINAL	REC	DATE
ADDENDUM B	REC	1/11/2021
		270-1731 CCS27 COORDINATE
		1910-6291 CCS83 COORDINATE
DATE STARTED		40846-10-D
DATE COMPLETED		

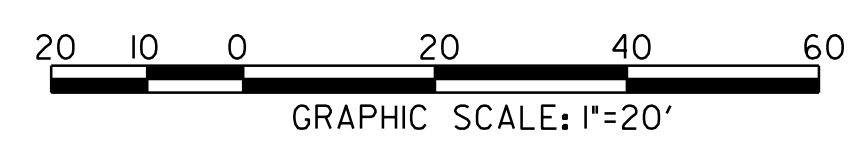

- EXISTING CONDITIONS & DEMOLITION SYMBOLOGY:**
- REMOVE EXISTING CONCRETE SIDEWALK
 - REMOVE EXISTING GRASS FIELD
 - REMOVE & STOCKPILE 12" OF EXIST. DG
 - REMOVE EXIST. DIRT TO BE USED AS FILL FOR PROJECT
 - REMOVE EXISTING FENCING
 - SAWCUT
 - REMOVE CURB & GUTTER
 - REMOVE EXISTING STORM DRAIN

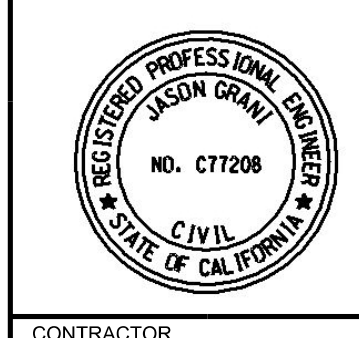

KAREN S. VAN ERT R.C.E 56991 EXP. 6-30-2021 DATE 10-15-2019
 ADDENDUM B

EXISTING UTILITIES NOTE:
 ALL EXISTING UTILITIES SHOWN ON THESE PLANS ARE PLOTTED FROM RECORD DATA AT THEIR APPROXIMATE LOCATIONS. UNDERGROUND FACILITIES MAY EXIST WHICH HAVE NOT BEEN REPORTED OR ARE NOT OF RECORD. CONTRACTOR SHALL VERIFY THE LOCATION OF ALL PERTINENT UTILITIES IN THE FIELD PRIOR TO THE START OF CONSTRUCTION.

CONTRACTOR'S NOTE:
 PROTECT ALL EXISTING UTILITIES IN PLACE UNLESS OTHERWISE NOTED.

CONTRACTOR'S NOTE:
 EXACT LOCATION OF EXISTING UTILITIES IS UNKNOWN. CONTRACTOR TO FIELD CONFIRM AND NOTIFY ENGINEER OF ANY DISCREPANCIES.

NOTE: CONTRACTOR TO POTHOLE AND CONFIRM LOCATION OF EXISTING SEWER PRIOR TO CONSTRUCTION.

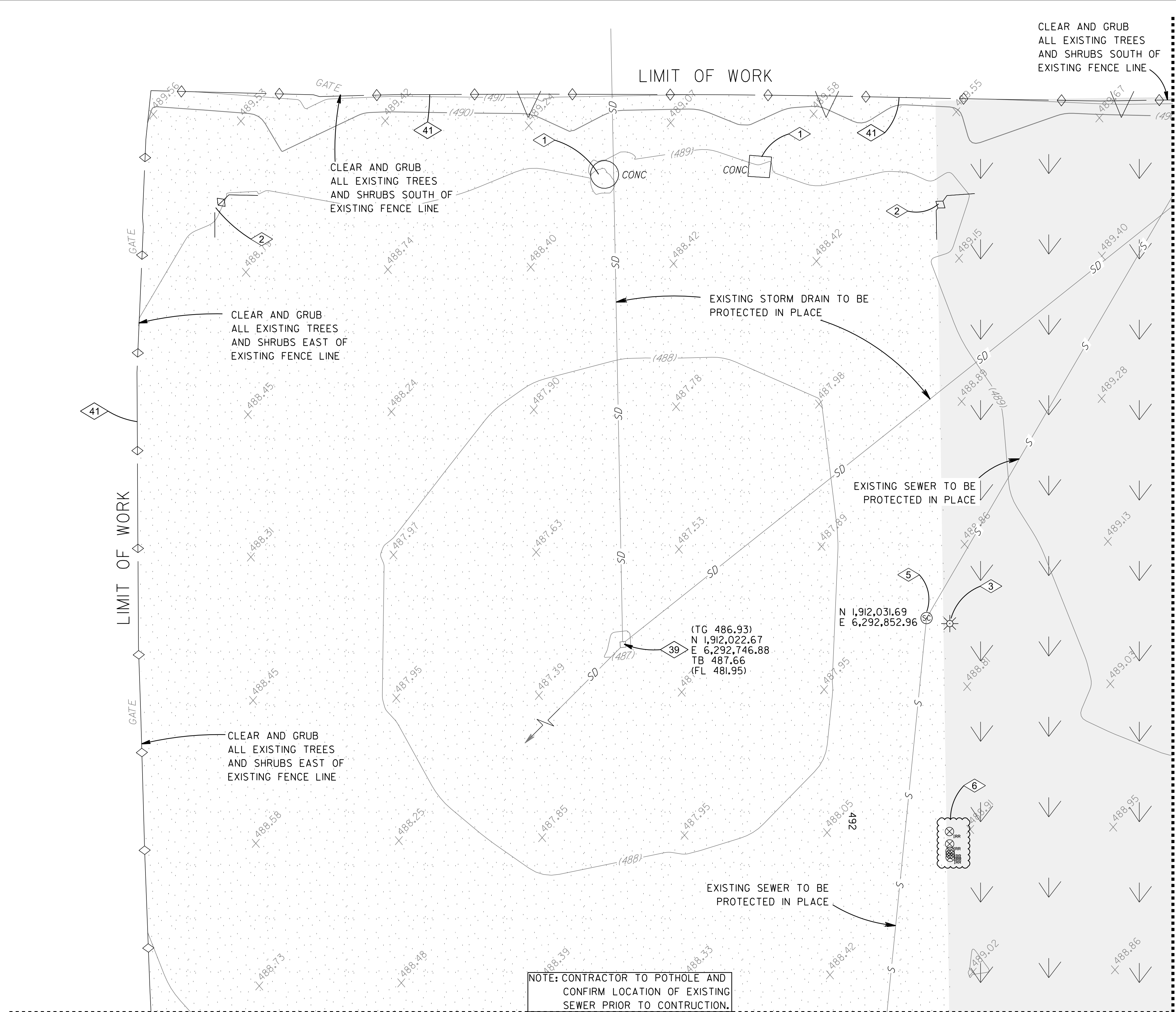

RICK ENGINEERING COMPANY
 5620 FRIARS ROAD
 SAN DIEGO, CA 92110
 619-291-0707
 (FAX) 619-291-4165
 rickengineering.com
 San Diego Riverside - Orange - Sacramento - San Luis Obispo - Phoenix - Tucson - Denver

IDENTIFICATION STAMP
 DIV. OF THE STATE ARCHITECT
 APP. 04-118244 INC.
 REVIEWED FOR
 SS FLS ACS
 DATE: 02.14.2020

- EXISTING CONDITIONS & DEMOLITION NOTES:**
- 1 REMOVE EXISTING CONCRETE PAD
 - 2 REMOVE EXISTING BACKSTOPS TO BE SALVAGED AND RELOCATED PER LANDSCAPE PLANS SHEETS L-1 THRU L-5
 - 3 REMOVE & SALVAGE EXISTING LIGHTING, TO BE REUSED PER ELECTRICAL PLANS. TURN OVER TO CITY PARKS & REC DURING DEMOLITION.
 - 4 REMOVE EXISTING CONCRETE FOOTING
 - 5 EXISTING SEWER CLEANOUT TO REMAIN AND PROTECT IN PLACE.
 - 6 EXISTING LATERAL AND MAIN IRRIGATION LINES ARE TO BE ABANDONED IN PLACE. ANY PIPING EXPOSED DURING CONSTRUCTION WORK SHALL BE REMOVED TO A DEPTH OF 12" BELOW FINISH SURFACE. SEE AS-BUILT DRAWINGS 18223-D FOR EXISTING LOCATION. ALL VALVES, MANIFOLDS, SPRINKLER HEADS AND SWING JOINTS ARE TO BE REMOVED AND TURNED OVER TO THE CITY OF SAN DIEGO.
 - 7 EXISTING TRANSFORMER TO REMAIN AND PROTECT IN PLACE
 - 8 REMOVE AND RELOCATE EXISTING DRAINAGE STRUCTURE AND GRATE.
 - 9 REMOVE EXISTING WATER VALVE AND CONCRETE VALVE BOX. CAP SERVICE LINE BELOW GRADE AND ABANDON IN PLACE.
 - 10 EXISTING TREE TO PROTECT IN PLACE
 - 11 EXISTING ELECTRICAL TRANSFORMERS TO BE RELOCATED. SEE ELECTRICAL PLANS.
 - 12 ADJUST TO FINISH GRADE EXISTING CORROSION TEST STATION
 - 13 ADJUST TO FINISH GRADE EXISTING TELEPHONE VAULT. CONTRACTOR TO COORDINATE WITH TELEPHONE COMPANY.
 - 14 ADJUST TO FINISH GRADE EXISTING TRAFFIC PULL BOX
 - 15 ADJUST TO FINISH GRADE EXISTING ELECTRIC PULL BOX
 - 16 ADJUST TO FINISH GRADE EXISTING AIR RELEASE VALVE
 - 17 ADJUST TO FINISH GRADE EXISTING BUS, TRAFFIC AND PEDESTRIAN CROSSING SIGN
 - 18 ADJUST TO FINISH GRADE EXISTING BUS STOP BENCHES
 - 19 EXISTING ELECTRICAL TRANSFORMER TO REMAIN AND PROTECT IN PLACE
 - 20 RELOCATE EXISTING IRRIGATION SEE LANDSCAPE PLANS
 - 21 EXISTING WATER VALVE TO BE REMOVED AND LINE CAPPED
 - 22 EXISTING SDG&E MANHOLE TO REMAIN AND PROTECT IN PLACE
 - 23 PROTECT EXISTING CURB & GUTTER
 - 24 EXISTING STORM DRAIN GRATE TO REMAIN AND PROTECT IN PLACE
 - 25 PROTECT EXISTING STREET LIGHT IN PLACE
 - 26 EXISTING TRAFFIC SIGNS TO REMAIN AND PROTECT IN PLACE
 - 27 ADJUST TO FINISH GRADE EXISTING COX MANHOLE. CONTRACTOR TO COORDINATE WITH COX COMMUNICATIONS.
 - 28 EXISTING CATHODIC PROTECTION AND SDG&E MANHOLE TO REMAIN AND PROTECT IN PLACE
 - 30 EXISTING CONCRETE SLOPE TO REMAIN AND PROTECT IN PLACE
 - 31 EXISTING CONCRETE PAD TO REMAIN AND PROTECT IN PLACE
 - 32 REMOVE EXISTING CURB RAMP
 - 33 REMOVE EXISTING FENCE TO PROPOSED PATHWAY AND ADD TERMINUS POST
 - 34 EXISTING CONCRETE SLOPE TO BE REMOVED
 - 35 EXISTING RUBBER PAD TO PROTECT IN PLACE
 - 36 EXISTING MOW CURB TO REMAIN AND PROTECT IN PLACE
 - 37 REMOVE EXISTING FIELD GUARD POSTS
 - 38 EXISTING SEWER MANHOLE TO REMAIN AND PROTECT IN PLACE
 - 39 REMOVE EXIST. DRAIN GRATE. TOP OF STRUCTURE TO BE BURIED 2' BELOW PROPOSED FINISH GRADE PER ROUGH GRADING PLANS. SEE DETAIL SHEET G-4.
 - 40 EXISTING IRRIGATION TO ADJUST TO FINISH GRADE
 - 41 EXISTING FENCE TO REMAIN AND PROTECT IN PLACE
 - 42 EXISTING BLEACHERS TO BE REMOVED AND TURNED OVER TO CITY PARKS AND RECREATION OR CITY RESIDENT ENGINEER
 - 46 REMOVE PORTIONS OF EXISTING FENCE. SEE LANDSCAPE PLANS, SHEETS L-1 THRU L-5 FOR PROPOSED FENCING
 - 47 REMOVE EXISTING BACKSTOP FENCING

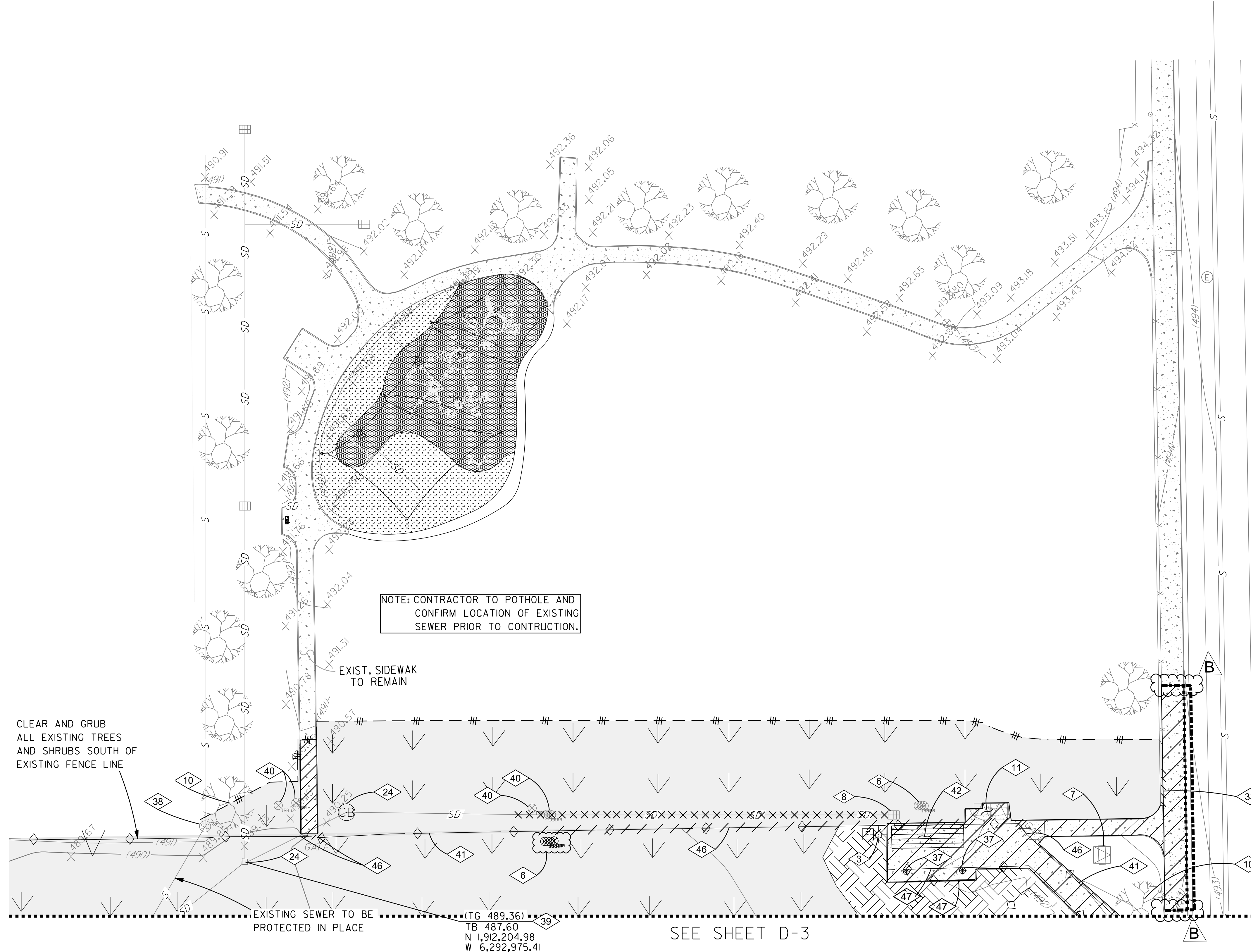

IMPORTANT NOTICE
 SECTION 4215/4217 OF THE GOVERNMENT CODE REQUIRES A DIG ALERT IDENTIFICATION NUMBER BE ISSUED BEFORE A "PERMIT TO EXCAVATE" WILL BE VALID. FOR YOUR DIG ALERT I.D. NUMBER, CALL UNDERGROUND SERVICE ALERT TOLL FREE 1-800-422-4133 AT LEAST TWO WORKING DAYS BEFORE YOU DIG.



EXISTING UTILITIES NOTE:
 ALL EXISTING UTILITIES SHOWN ON THESE PLANS ARE PLOTTED FROM RECORD DATA AT THEIR APPROXIMATE LOCATIONS. UNDERGROUND FACILITIES MAY EXIST WHICH HAVE NOT BEEN REPORTED OR ARE NOT OF RECORD. CONTRACTOR SHALL VERIFY THE LOCATION OF ALL PERTINENT UTILITIES IN THE FIELD PRIOR TO THE START OF CONSTRUCTION.

CONTRACTOR'S NOTE:
 PROTECT ALL EXISTING UTILITIES IN PLACE UNLESS OTHERWISE NOTED.

CONTRACTOR'S NOTE:
 EXACT LOCATION OF EXISTING UTILITIES IS UNKNOWN. CONTRACTOR TO FIELD CONFIRM AND NOTIFY ENGINEER OF ANY DISCREPANCIES.

- EXISTING CONDITIONS & DEMOLITION SYMBOLOLOGY:**
- REMOVE EXISTING CONCRETE SIDEWALK
 - REMOVE EXISTING GRASS FIELD
 - REMOVE & STOCKPILE EXISTING DG
 - REMOVE EXISTING DIRT TO BE USED AS FILL FOR PROJECT
 - REMOVE EXISTING FENCING
 - REMOVE EXISTING CURB & GUTTER
 - SAWCUT
 - REMOVE EXISTING STORM DRAIN

RICK ENGINEERING COMPANY
 5620 FRIARS ROAD
 SAN DIEGO, CA 92110
 619-291-0707
 (FAX) 619-291-4165
 rickengineering.com
 J-17721

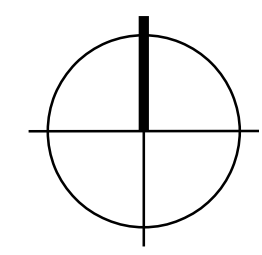
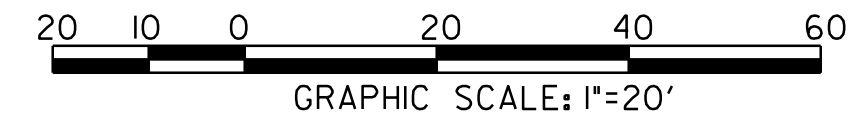

Karen S. Van Ert
 KAREN S. VAN ERT R.C.E. 56991 EXP. 6-30-2021

10-15-2019 DATE

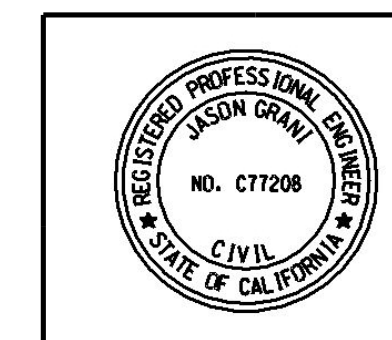

WANGENHEIM NEIGHBORHOOD JOINT USE FACILITY DEMOLITION PLANS		CITY OF SAN DIEGO, CALIFORNIA PUBLIC WORKS DEPARTMENT SHEET 11 OF 142 SHEETS		WBS S-15007
		APPROVED: <i>Jason Grani</i> FOR CITY ENGINEER JASON GRANI PRINT NAME DATE: 10/13/2020 RCE#: 77208	SUBMITTED BY: YOVANNA LEWIS PROJECT MANAGER CHECKED BY: MEHDI RASHIDPOUR-HARISH PROJECT ENGINEER	DATE STARTED: 10/15/2019 DATE COMPLETED:
CONTRACTOR: <i>Jason Grani</i> INSPECTOR:		40846-11-D		

B SAWCUT LIMITS ADDED
 DEMO NOTES REVISED

ADDENDUM B

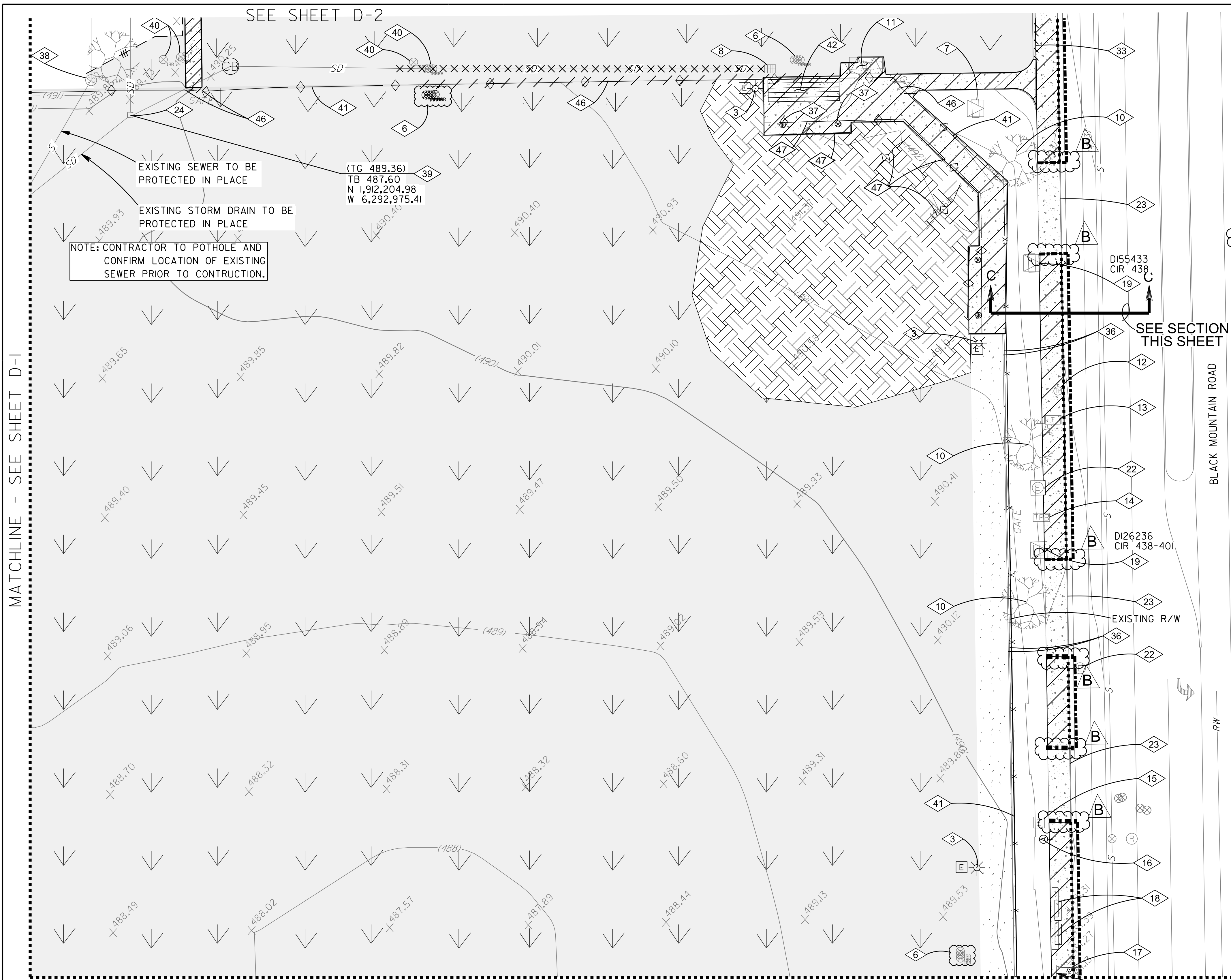

- EXISTING CONDITIONS & DEMOLITION NOTES:**
- 1 REMOVE EXISTING CONCRETE PAD
 - 2 REMOVE EXISTING BACKSTOPS TO BE SALVAGED AND RELOCATED PER LANDSCAPE PLANS SHEETS L-1 THRU L-5
 - 3 REMOVE & SALVAGE EXISTING LIGHTING, TO BE REUSED PER ELECTRICAL PLANS. TURN OVER TO CITY PARKS & REC DURING DEMOLITION.
 - 4 REMOVE EXISTING CONCRETE FOOTING
 - 5 EXISTING SEWER CLEANOUT TO REMAIN AND PROTECT IN PLACE. BURY TO PROPOSED FINISH GRADE PER ROUGH GRADING PLANS.
 - 6 EXISTING LATERAL AND MAIN IRRIGATION LINES ARE TO BE ABANDONED IN PLACE. ANY PIPING EXPOSED DURING CONSTRUCTION WORK SHALL BE REMOVED TO A DEPTH OF 12" BELOW FINISH SURFACE. SEE AS-BUILT DRAWINGS 18223-D FOR EXISTING LOCATION. ALL VALVES, MANIFOLDS, SPRINKLER HEADS AND SWING JOINTS ARE TO BE REMOVED AND TURNED OVER TO THE CITY OF SAN DIEGO.
 - 7 EXISTING TRANSFORMER TO REMAIN AND PROTECT IN PLACE
 - 8 REMOVE AND RELOCATE EXISTING DRAINAGE STRUCTURE AND GRATE.
 - 9 REMOVE EXISTING WATER VALVE AND CONCRETE VALVE BOX. CAP SERVICE LINE BELOW GRADE AND ABANDON IN PLACE.
 - 10 EXISTING TREE TO PROTECT IN PLACE
 - 11 EXISTING ELECTRICAL TRANSFORMERS TO BE RELOCATED. SEE ELECTRICAL PLANS.
 - 12 ADJUST TO FINISH GRADE EXISTING CORROSION TEST STATION
 - 13 ADJUST TO FINISH GRADE EXISTING TELEPHONE VAULT. CONTRACTOR TO COORDINATE WITH TELEPHONE COMPANY.
 - 14 ADJUST TO FINISH GRADE EXISTING TRAFFIC PULL BOX
 - 15 ADJUST TO FINISH GRADE EXISTING ELECTRIC PULL BOX
 - 16 ADJUST TO FINISH GRADE EXISTING AIR RELEASE VALVE
 - 17 ADJUST TO FINISH GRADE EXISTING BUS, TRAFFIC AND PEDESTRIAN CROSSING SIGN
 - 18 ADJUST TO FINISH GRADE EXISTING BUS STOP BENCHES
 - 19 EXISTING ELECTRICAL TRANSFORMER TO REMAIN AND PROTECT IN PLACE
 - 20 RELOCATE EXISTING IRRIGATION SEE LANDSCAPE PLANS
 - 21 EXISTING WATER VALVE TO BE REMOVED AND LINE CAPPED
 - 22 EXISTING SDG&E MANHOLE TO REMAIN AND PROTECT IN PLACE
 - 23 PROTECT EXISTING CURB & GUTTER
 - 24 EXISTING STORM DRAIN GRATE TO REMAIN AND PROTECT IN PLACE
 - 25 PROTECT EXISTING STREET LIGHT IN PLACE
 - 26 EXISTING TRAFFIC SIGNS TO REMAIN AND PROTECT IN PLACE
 - 27 ADJUST TO FINISH GRADE EXISTING COX MANHOLE. CONTRACTOR TO COORDINATE WITH COX COMMUNICATIONS.
 - 28 EXISTING CATHODIC PROTECTION AND SDG&E MANHOLE TO REMAIN AND PROTECT IN PLACE
 - 30 EXISTING CONCRETE SLOPE TO REMAIN AND PROTECT IN PLACE
 - 31 EXISTING CONCRETE PAD TO REMAIN AND PROTECT IN PLACE
 - 32 REMOVE EXISTING CURB RAMP
 - 33 REMOVE EXISTING FENCE TO PROPOSED PATHWAY AND ADD TERMINUS POST
 - 34 EXISTING CONCRETE SLOPE TO BE REMOVED
 - 35 EXISTING RUBBER PAD TO PROTECT IN PLACE
 - 36 EXISTING MOW CURB TO REMAIN AND PROTECT IN PLACE
 - 37 REMOVE EXISTING FIELD GUARD POSTS
 - 38 EXISTING SEWER MANHOLE TO REMAIN AND PROTECT IN PLACE
 - 39 REMOVE EXIST. DRAIN GRATE. TOP OF STRUCTURE TO BE BURIED 2' BELOW PROPOSED FINISH GRADE PER ROUGH GRADING PLANS. SEE DETAIL SHEET C-4.
 - 40 EXISTING IRRIGATION TO ADJUST TO FINISH GRADE
 - 41 EXISTING FENCE TO REMAIN AND PROTECT IN PLACE
 - 42 EXISTING BLEACHERS TO BE REMOVED AND TURNED OVER TO CITY PARKS AND RECREATION OR CITY RESIDENT ENGINEER
 - 46 REMOVE PORTIONS OF EXISTING FENCE. SEE LANDSCAPE PLANS, SHEETS L-1 THRU L-5 FOR PROPOSED FENCING
 - 47 REMOVE EXISTING BACKSTOP FENCING

IDENTIFICATION STAMP
 DIV. OF THE STATE ARCHITECT
 APP. 04-118244 INC.
 REVIEWED FOR
 SS FLS ACS
 DATE: 02.14.2020

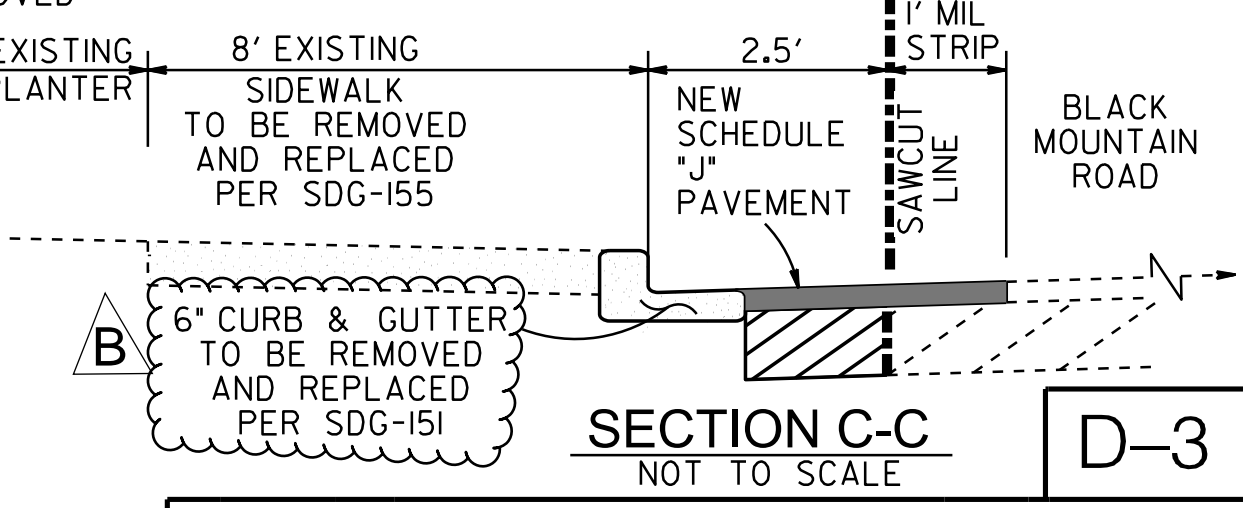
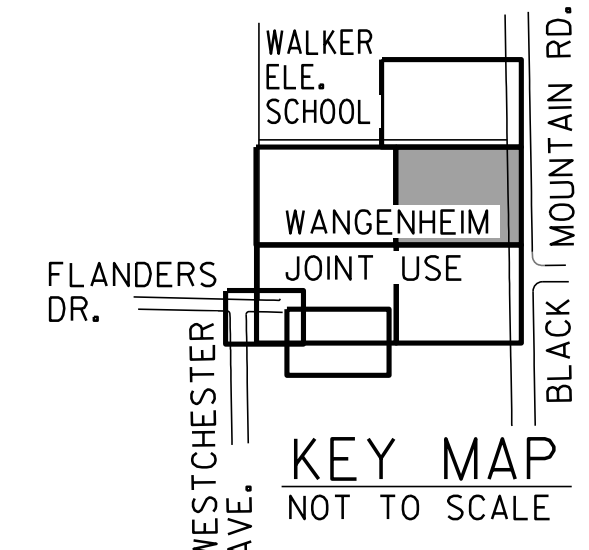

GRAPHIC SCALE: 1"=20'
CAUTION:
 ! 3" HP GAS!
 CONTRACTOR TO VERIFY EXACT LOCATION AND MUST NOTIFY SDG&E IN ADVANCE PRIOR TO EXCAVATION. SDG&E STAND BY REQUIRED.

IMPORTANT NOTICE
 SECTION 425/427 OF THE GOVERNMENT CODE REQUIRES A DIG ALERT IDENTIFICATION NUMBER BE ISSUED BEFORE A "PERMIT TO EXCAVATE" WILL BE VALID. FOR YOUR DIG ALERT I.D. NUMBER, CALL UNDERGROUND SERVICE ALERT TOLL FREE 1-800-422-4133 AT LEAST TWO WORKING DAYS BEFORE YOU DIG. CALL 811 BEFORE YOU DIG J-17721

DIG ALERT 811

RICK ENGINEERING COMPANY
 5620 FRIARS ROAD
 SAN DIEGO, CA 92110
 619-291-0707
 (FAX) 619-291-4165
 rickengineering.com
 San Diego Riverside - Orange - Sacramento - San Luis Obispo - Phoenix - Tucson - Denver

EXISTING UTILITIES NOTE:
 ALL EXISTING UTILITIES SHOWN ON THESE PLANS ARE PLOTTED FROM RECORD DATA AT THEIR APPROXIMATE LOCATIONS. UNDERGROUND FACILITIES MAY EXIST WHICH HAVE NOT BEEN REPORTED OR ARE NOT OF RECORD. CONTRACTOR SHALL VERIFY THE LOCATION OF ALL PERTINENT UTILITIES IN THE FIELD PRIOR TO THE START OF CONSTRUCTION.

CONTRACTOR'S NOTE:
 PROTECT ALL EXISTING UTILITIES IN PLACE UNLESS OTHERWISE NOTED.

CONTRACTOR'S NOTE:
 EXACT LOCATION OF EXISTING UTILITIES IS UNKNOWN. CONTRACTOR TO FIELD CONFIRM AND NOTIFY ENGINEER OF ANY DISCREPANCIES.

EXISTING CONDITIONS & DEMOLITION SYMBOLOLOGY:

- REMOVE EXISTING CONCRETE SIDEWALK
- REMOVE EXISTING GRASS FIELD
- REMOVE & STOCKPILE EXISTING DG
- REMOVE EXISTING DIRT TO BE USED AS FILL FOR PROJECT
- REMOVE EXISTING FENCING
- REMOVE EXISTING CURB & GUTTER
- SAWCUT
- REMOVE EXISTING STORM DRAIN

Kam Dan

R.C.E. 56991 EXP. 6-30-2021 DATE 10-15-2019

10/15/2019

WANGENHEIM NEIGHBORHOOD JOINT USE FACILITY DEMOLITION PLAN

CITY OF SAN DIEGO, CALIFORNIA
 PUBLIC WORKS DEPARTMENT
 SHEET 12 OF 142 SHEETS

APPROVED: *[Signature]* 10/13/2020
 FOR CITY ENGINEER: JASON GRANI DATE: 7/20/20
 PRINT NAME: RCE#

SUBMITTED BY: YOVANNA LEWIS PROJECT MANAGER
 CHECKED BY: MEHDI RASHIDPOUR-HARISH PROJECT ENGINEER

DESCRIPTION	BY	APPROVED	DATE	FILMED
ORIGINAL	REC			
ADDENDUM B	REC	<i>[Signature]</i>	1/11/2021	

DATE STARTED: DATE COMPLETED: 40846-12-D

MATCHLINE - SEE SHEET D-1

EXISTING CONDITIONS & DEMOLITION SYMOLOGY:

- REMOVE EXISTING CONCRETE SIDEWALK
- REMOVE EXISTING GRASS FIELD
- REMOVE & STOCKPILE EXISTING DG AS FILL FOR PROJECT
- REMOVE EXISTING FENCING
- SAWCUT
- REMOVE EXIST. AC BERM/CURB & GUTTER
- REMOVE EXISTING STORM DRAIN
- REMOVE EXISTING ASPHALT
- REMOVE EXISTING CONCRETE DITCH

NOTE: CONTRACTOR TO POT HOLE AND CONFIRM LOCATION OF EXISTING SEWER PRIOR TO CONSTRUCTION.

IMPORTANT NOTICE
SECTION 4215/4217 OF THE GOVERNMENT CODE REQUIRES A DIG ALERT IDENTIFICATION NUMBER BE ISSUED BEFORE A "PERMIT TO EXCAVATE" WILL BE VALID. FOR YOUR DIG ALERT I.D. NUMBER, CALL UNDERGROUND SERVICE ALERT TOLL FREE 1-800-422-4133 AT LEAST TWO WORKING DAYS BEFORE YOU DIG.



CALL 811 BEFORE YOU DIG

UPSIZE EXIST. 1" METER TO 1-1/2" METER

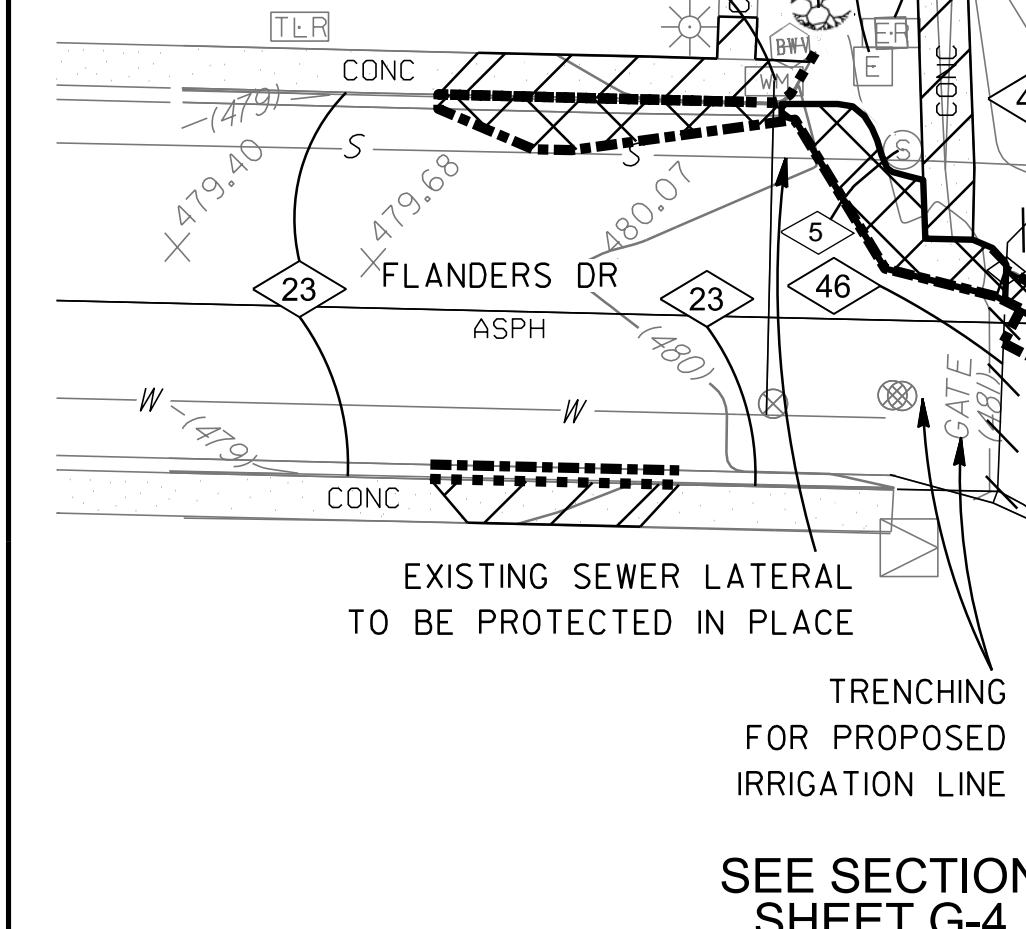

EXISTING UTILITIES NOTE:
ALL EXISTING UTILITIES SHOWN ON THESE PLANS ARE PLOTTED FROM RECORD DATA AT THEIR APPROXIMATE LOCATIONS. UNDERGROUND FACILITIES MAY EXIST WHICH HAVE NOT BEEN REPORTED OR ARE NOT OF RECORD. CONTRACTOR SHALL VERIFY THE LOCATION OF ALL PERTINENT UTILITIES IN THE FIELD PRIOR TO THE START OF CONSTRUCTION.

CONTRACTOR'S NOTE:
PROTECT ALL EXISTING UTILITIES IN PLACE UNLESS OTHERWISE NOTED.

CONTRACTOR'S NOTE:
EXACT LOCATION OF EXISTING UTILITIES IS UNKNOWN. CONTRACTOR TO FIELD CONFIRM AND NOTIFY ENGINEER OF ANY DISCREPANCIES.

RICK ENGINEERING COMPANY
5620 FRIARS ROAD
SAN DIEGO, CA 92110
619-291-0707
619-291-4165
rickengineering.com
San Diego Riverside - Orange - Sacramento - San Luis Obispo - Phoenix - Tucson - Denver

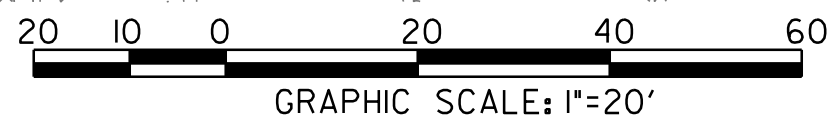
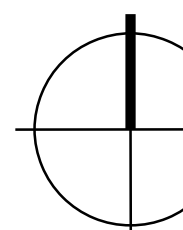

KAREN S. VAN ERT R.C.E 56991 EXP. 6-30-2021 DATE 10-15-2019

ADDENDUM B

EXISTING CONDITIONS & DEMOLITION NOTES:

- 1 REMOVE EXISTING CONCRETE PAD
- 2 REMOVE EXISTING BACKSTOPS TO BE SALVAGED AND RELOCATED. LANDSCAPE PLANS SHEETS L-1 THRU L-5
- 3 REMOVE & SALVAGE EXISTING LIGHTING, TO BE REUSED PER ELECTRICAL PLANS. TURN OVER TO CITY PARKS & REC DURING DEMOLITION.
- 4 REMOVE EXISTING CONCRETE FOOTING
- 5 EXISTING SEWER CLEANOUT TO REMAIN AND PROTECT IN PLACE. ABANDONED IN PLACE. ANY PIPING EXPOSED DURING CONSTRUCTION WORK SHALL BE REMOVED TO A DEPTH OF 12" BELOW FINISH SURFACE. SEE AS-BUILT DRAWINGS 18223-D FOR EXISTING LOCATION. ALL VALVES, MANIFOLDS, SPRINKLER HEADS AND SWING JOINTS ARE TO BE REMOVED AND TURNED OVER TO THE CITY OF SAN DIEGO.
- 6 EXISTING TRANSFORMER TO REMAIN AND PROTECT IN PLACE
- 7 REMOVE AND RELOCATE EXISTING DRAINAGE STRUCTURE AND GRATE.
- 8 REMOVE EXISTING WATER VALVE AND CONCRETE VALVE BOX. CAP SERVICE LINE BELOW GRADE AND ABANDON IN PLACE.
- 9 EXISTING TREE TO PROTECT IN PLACE
- 10 EXISTING ELECTRICAL TRANSFORMERS TO BE RELOCATED. SEE ELECTRICAL PLANS
- 11 ADJUST TO FINISH GRADE EXISTING CORROSION TEST STATION
- 12 ADJUST TO FINISH GRADE EXISTING TELEPHONE VAULT. CONTRACTOR TO COORDINATE WITH TELEPHONE COMPANY.
- 13 ADJUST TO FINISH GRADE EXISTING TRAFFIC PULL BOX
- 14 ADJUST TO FINISH GRADE EXISTING ELECTRIC PULL BOX
- 15 ADJUST TO FINISH GRADE EXISTING AIR RELEASE VALVE
- 16 ADJUST TO FINISH GRADE EXISTING BUS, TRAFFIC AND PEDESTRIAN CROSSING SIGN
- 17 ADJUST TO FINISH GRADE EXISTING BUS STOP BENCHES
- 18 EXISTING ELECTRICAL TRANSFORMER TO REMAIN AND PROTECT IN PLACE
- 19 RELOCATE EXISTING IRRIGATION SEE LANDSCAPE PLANS
- 20 EXISTING WATER VALVE TO BE REMOVED AND LINE CAPPED
- 21 EXISTING SDG&E MANHOLE TO REMAIN AND PROTECT IN PLACE
- 22 PROTECT EXISTING CURB & GUTTER
- 23 EXISTING STORM DRAIN GRATE TO REMAIN AND PROTECT IN PLACE
- 24 PROTECT EXISTING STREET LIGHT IN PLACE
- 25 EXISTING TRAFFIC SIGNS TO REMAIN AND PROTECT IN PLACE
- 26 ADJUST TO FINISH GRADE EXISTING COX MANHOLE. CONTRACTOR TO COORDINATE WITH COX COMMUNICATIONS.
- 27 EXISTING CATHODIC PROTECTION AND SDG&E MANHOLE TO REMAIN AND PROTECT IN PLACE
- 28 EXISTING CONCRETE SLOPE TO REMAIN AND PROTECT IN PLACE
- 29 EXISTING CONCRETE PAD TO REMAIN AND PROTECT IN PLACE
- 30 REMOVE EXISTING CURB RAMP
- 31 REMOVE EXISTING FENCE TO PROPOSED PATHWAY AND ADD TERMINUS POST
- 32 EXISTING CONCRETE SLOPE TO BE REMOVED
- 33 EXISTING RUBBER PAD TO PROTECT IN PLACE
- 34 EXISTING MOW CURB TO REMAIN AND PROTECT IN PLACE
- 35 REMOVE EXISTING FIELD GUARD POSTS
- 36 EXISTING SEWER MANHOLE TO REMAIN AND PROTECT IN PLACE
- 37 REMOVE EXIST. DRAIN GRATE. TOP OF STRUCTURE TO BE BURIED 2' BELOW PROPOSED FINISH GRADE PER ROUGH GRADING PLANS. SEE DETAIL SHEET G-4.
- 38 EXISTING IRRIGATION TO ADJUST TO FINISH GRADE
- 39 EXISTING FENCE TO REMAIN AND PROTECT IN PLACE
- 40 EXISTING BLEACHERS TO BE REMOVED AND TURNED OVER TO CITY PARKS AND RECREATION OR CITY RESIDENT ENGINEER
- 41 EXISTING BOOSTER PUMP TO REMAIN AND PROTECT IN PLACE
- 42 ADJUST EXISTING WATER METER TO FINISH GRADE
- 43 EXISTING ELECTRICAL PULL BOX TO BE RELOCATED
- 44 REMOVE PORTIONS OF EXISTING FENCE. SEE LANDSCAPE PLANS, SHEETS L-1 THRU L-5 FOR PROPOSED FENCING

IDENTIFICATION STAMP
DIV. OF THE STATE ARCHITECT
APP. 04-118244 INC.
REVIEWED FOR
SS FLS ACS
DATE: 02.14.2020

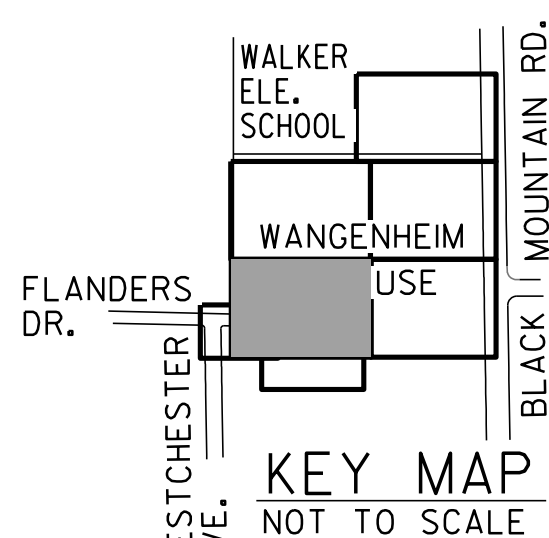

WANGENHEIM NEIGHBORHOOD JOINT USE FACILITY
DEMOLITION PLAN

CITY OF SAN DIEGO, CALIFORNIA PUBLIC WORKS DEPARTMENT SHEET 13 OF 142 SHEETS		WBS S-15007
APPROVED: JASON GRANI FOR CITY ENGINEER PRINT NAME	DATE: 10/13/2020 77208	SUBMITTED BY: YOVANNA LEWIS PROJECT MANAGER
DESCRIPTION	BY	APPROVED
ORIGINAL	REC	1/11/2021
ADDENDUM B	REC	1/11/2021
CREATED BY: MEHDI RASHIDPOUR-HARISI PROJECT ENGINEER		270-1731 CCS27 COORDINATE
DATE STARTED		1910-6291 CCS83 COORDINATE
DATE COMPLETED		40846-13-D



CONTRACTOR INSPECTOR DATE STARTED DATE COMPLETED

ADDENDUM B

MATCHLINE - SEE SHEET D-3

IDENTIFICATION STAMP
 DIV. OF THE STATE ARCHITECT
 APP. 04-118244 INC.
 REVIEWED FOR
 SS FLS ACS
 DATE: 02.14.2020

EXISTING UTILITIES NOTE:
 ALL EXISTING UTILITIES SHOWN ON THESE PLANS ARE PLOTTED FROM RECORD DATA AT THEIR APPROXIMATE LOCATIONS. UNDERGROUND FACILITIES MAY EXIST WHICH HAVE NOT BEEN REPORTED OR ARE NOT OF RECORD. CONTRACTOR SHALL VERIFY THE LOCATION OF ALL PERTINENT UTILITIES IN THE FIELD PRIOR TO THE START OF CONSTRUCTION.

CONTRACTOR'S NOTE:
 PROTECT ALL EXISTING UTILITIES IN PLACE UNLESS OTHERWISE NOTED.

CONTRACTOR'S NOTE:
 EXACT LOCATION OF EXISTING UTILITIES IS UNKNOWN. CONTRACTOR TO FIELD CONFIRM AND NOTIFY ENGINEER OF ANY DISCREPANCIES.

EXISTING CONDITIONS & DEMOLITION SYMBOLOLOGY:

	REMOVE EXISTING CONCRETE SIDEWALK		REMOVE EXISTING FENCING
	REMOVE EXISTING GRASS FIELD		SAWCUT
	REMOVE & STOCKPILE EXISTING DG AS FILL FOR PROJECT		REMOVE CURB & GUTTER
	REMOVE EXISTING STORM DRAIN		REMOVE EXISTING STORM DRAIN

- EXISTING CONDITIONS & DEMOLITION NOTES:**
- 1 REMOVE EXISTING CONCRETE PAD
 - 2 REMOVE EXISTING BACKSTOPS TO BE SALVAGED AND RE LANDSCAPE PLANS SHEETS L-1 THRU L-5
 - 3 REMOVE & SALVAGE EXISTING LIGHTING. TO BE REUSED PER ELECTRICAL PLANS. TURN OVER TO CITY PARKS & REC DURING DEMOLITION.
 - 4 REMOVE EXISTING CONCRETE FOOTING
 - 5 EXISTING SEWER CLEANOUT TO REMAIN AND PROTECT IN PLACE. BURY TO PROPOSED FINISH GRADE PER ROUGH GRADING PLANS. EXISTING LATERAL AND MAIN IRRIGATION LINES ARE TO BE ABANDONED IN PLACE. ANY PIPING EXPOSED DURING CONSTRUCTION WORK SHALL BE REMOVED TO A DEPTH OF 12" BELOW FINISH SURFACE. SEE AS-BUILT DRAWINGS 18223-D FOR EXISTING LOCATION. ALL VALVES, MANIFOLDS, SPRINKLER HEADS AND SWING JOINTS ARE TO BE REMOVED AND TURNED OVER TO THE CITY OF SAN DIEGO.
 - 6 EXISTING TRANSFORMER TO REMAIN AND PROTECT IN PLACE
 - 7 REMOVE AND RELOCATE EXISTING DRAINAGE STRUCTURE AND GRATE.
 - 8 REMOVE EXISTING WATER VALVE AND CONCRETE VALVE BOX. CAP SERVICE LINE BELOW GRADE AND ABANDON IN PLACE.
 - 9 EXISTING TREE TO PROTECT IN PLACE
 - 10 EXISTING ELECTRICAL TRANSFORMERS TO BE RELOCATED. SEE ELECTRICAL PLANS.
 - 11 ADJUST TO FINISH GRADE EXISTING CORROSION TEST STATION
 - 12 ADJUST TO FINISH GRADE EXISTING TELEPHONE VAULT. CONTRACTOR TO COORDINATE WITH TELEPHONE COMPANY.
 - 13 ADJUST TO FINISH GRADE EXISTING TRAFFIC PULL BOX
 - 14 ADJUST TO FINISH GRADE EXISTING ELECTRIC PULL BOX
 - 15 ADJUST TO FINISH GRADE EXISTING AIR RELEASE VALVE
 - 16 ADJUST TO FINISH GRADE EXISTING BUS, TRAFFIC AND PEDESTRIAN CROSSING SIGN
 - 17 ADJUST TO FINISH GRADE EXISTING BUS STOP BENCHES
 - 18 EXISTING ELECTRICAL TRANSFORMER TO REMAIN AND PROTECT IN PLACE
 - 19 RELOCATE EXISTING IRRIGATION SEE LANDSCAPE PLANS
 - 20 EXISTING WATER VALVE TO BE REMOVED AND LINE CAPPED
 - 21 EXISTING SDG&E MANHOLE TO REMAIN AND PROTECT IN PLACE
 - 22 PROTECT EXISTING CURB & GUTTER
 - 23 EXISTING STORM DRAIN GRATE TO REMAIN AND PROTECT IN PLACE
 - 24 PROTECT EXISTING STREET LIGHT IN PLACE
 - 25 EXISTING TRAFFIC SIGNS TO REMAIN AND PROTECT IN PLACE
 - 26 ADJUST TO FINISH GRADE EXISTING COX MANHOLE. CONTRACTOR TO COORDINATE WITH COX COMMUNICATIONS.
 - 27 EXISTING CATHODIC PROTECTION AND SDG&E MANHOLE TO REMAIN AND PROTECT IN PLACE
 - 28 EXISTING CONCRETE SLOPE TO REMAIN AND PROTECT IN PLACE
 - 29 EXISTING CONCRETE PAD TO REMAIN AND PROTECT IN PLACE
 - 30 REMOVE EXISTING CURB RAMP
 - 31 REMOVE EXISTING FENCE TO PROPOSED PATHWAY AND ADD TERMINUS POST
 - 32 EXISTING CONCRETE SLOPE TO BE REMOVED
 - 33 EXISTING RUBBER PAD TO PROTECT IN PLACE
 - 34 EXISTING MOW CURB TO REMAIN AND PROTECT IN PLACE
 - 35 REMOVE EXISTING FIELD GUARD POSTS
 - 36 EXISTING SEWER MANHOLE TO REMAIN AND PROTECT IN PLACE
 - 37 REMOVE EXIST. DRAIN GRATE. TOP OF STRUCTURE TO BE BURIED 2' BELOW PROPOSED FINISH GRADE PER ROUGH GRADING PLANS. SEE DETAIL SHEET G-4.
 - 38 EXISTING IRRIGATION TO ADJUST TO FINISH GRADE
 - 39 EXISTING FENCE TO REMAIN AND PROTECT IN PLACE
 - 40 EXISTING BLEACHERS TO BE REMOVED AND TURNED OVER TO CITY PARKS AND RECREATION OR CITY RESIDENT ENGINEER
 - 41 REMOVE PORTIONS OF EXISTING FENCE. SEE LANDSCAPE PLANS, SHEETS L-1 THRU L-5 FOR PROPOSED FENCING
 - 42 REMOVE EXISTING BACKSTOP FENCING

MATCHLINE - SEE SHEET D-4

SEE SECTION SHEET D-3

BLACK MOUNTAIN ROAD

WALKER ELE. SCHOOL

KEY MAP NOT TO SCALE

CAUTION: 13" HP GAS!
 CONTRACTOR TO VERIFY EXACT LOCATION AND MUST NOTIFY SDG&E IN ADVANCE PRIOR TO EXCAVATION. SDG&E STAND BY REQUIRED.

RICK ENGINEERING COMPANY
 5620 FRIARS ROAD
 SAN DIEGO, CA 92110
 619-291-0707
 (FAX) 619-291-4165
 rickengineering.com
 San Diego Riverside - Orange - Sacramento - San Luis Obispo - Phoenix - Tucson - Denver



IMPORTANT NOTICE
 SECTION 4215/4217 OF THE GOVERNMENT CODE REQUIRES A DIG ALERT IDENTIFICATION NUMBER BE ISSUED BEFORE A "PERMIT TO EXCAVATE" WILL BE VALID. FOR YOUR DIG ALERT I.D. NUMBER, CALL UNDERGROUND SERVICE ALERT TOLL FREE 1-800-422-4133 AT LEAST TWO WORKING DAYS BEFORE YOU DIG.

Karen S. Van Ert
 KAREN S. VAN ERT R.C.E 56991 EXP. 6-30-2021



WANGENHEIM NEIGHBORHOOD JOINT USE FACILITY
DEMOLITION PLAN

CITY OF SAN DIEGO, CALIFORNIA
 PUBLIC WORKS DEPARTMENT
 SHEET 14 OF 142 SHEETS

WBS S-15007

APPROVED: *Jason Gran* 10/13/2020
 FOR CITY ENGINEER JASON GRANI DATE 77208
 PRINT NAME RCE#

SUBMITTED BY: YOVANNA LEWIS PROJECT MANAGER
 CHECKED BY: MEHDI RASHIDPOUR-HARISI PROJECT ENGINEER

DESCRIPTION	BY	APPROVED	DATE	FILMED
ORIGINAL	REC			
ADDENDUM B	REC	<i>SS</i>	1/11/2021	

DATE STARTED: 10/15/2019
 DATE COMPLETED: 10/15/2019

CONTRACTOR: 40846-14-D
 INSPECTOR:

D-5

IDENTIFICATION STAMP
 DIV. OF THE STATE ARCHITECT
 APP. 04-118244 INC.
 REVIEWED FOR
 SS FLS ACS
 DATE: 02.14.2020

CONSTRUCTION LEGEND:

- DG-SEE LANDSCAPE PLANS
- CLAY INFIELD
- GRASS/FIELD
- CONCRETE
- LANDSCAPE PLANTER

- 1 GRASS SWALE PER DETAIL SHEET G-4
- 2 BACKSTOP SEE SHEET L-7 FOR DETAIL

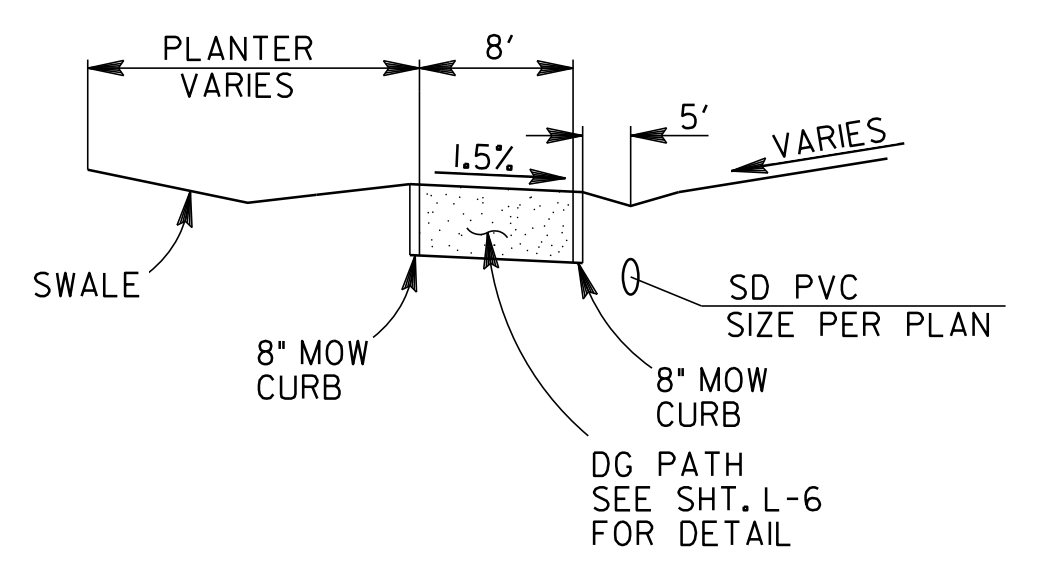

SECTION A-A
NOT TO SCALE

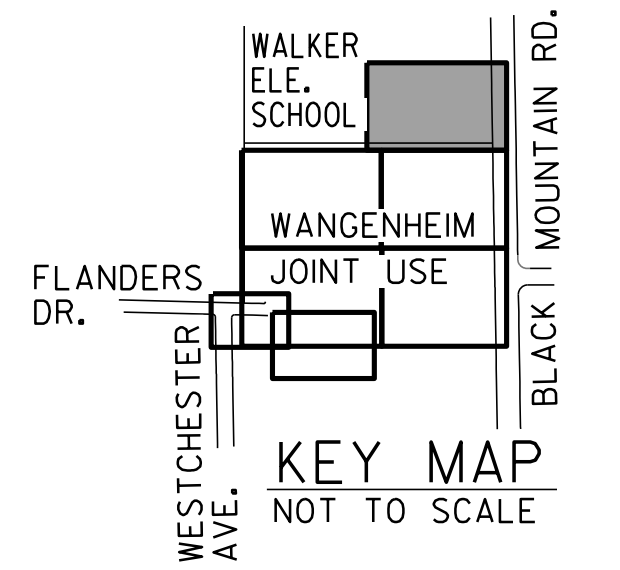

IMPORTANT NOTICE
 SECTION 4215/4217 OF THE GOVERNMENT CODE REQUIRES A DIG ALERT IDENTIFICATION NUMBER BE ISSUED BEFORE A "PERMIT TO EXCAVATE" WILL BE VALID. FOR YOUR DIG ALERT I.D. NUMBER, CALL UNDERGROUND SERVICE ALERT TOLL FREE 1-800-422-4133 AT LEAST TWO WORKING DAYS BEFORE YOU DIG.

WANGENHEIM NEIGHBORHOOD JOINT USE FACILITY

ROUGH GRADING PLANS

CITY OF SAN DIEGO, CALIFORNIA
 PUBLIC WORKS DEPARTMENT
 SHEET 16 OF 142 SHEETS

APPROVED FOR CITY ENGINEER JASON GRANI PRINT NAME	DATE 10/13/2020 77208	PROJECT MANAGER YOVANNA LEWIS
DESCRIPTION BY	APPROVED DATE FILMED	PROJECT ENGINEER MEHDI RASHIDPOUR-HARISH
ORIGINAL REC	1/11/2021	270-1731
ADDENDUM B REC		CCS27 COORDINATE
		1910-6291
		CCS83 COORDINATE
CONTRACTOR INSPECTOR		40846-16-D

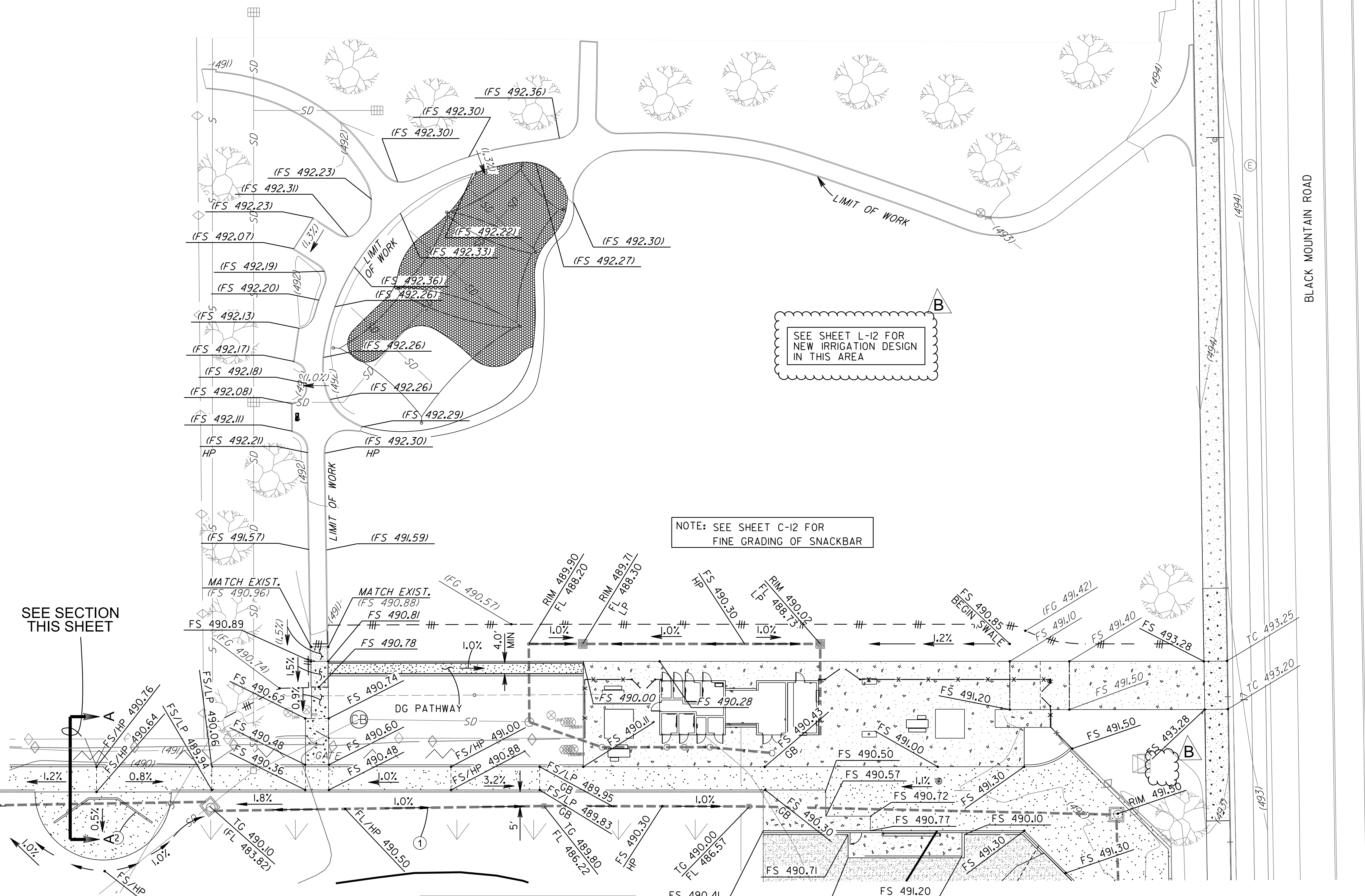

SEE SHEET L-12 FOR NEW IRRIGATION DESIGN IN THIS AREA

NOTE: SEE SHEET C-12 FOR FINE GRADING OF SNACKBAR

SEE SECTION THIS SHEET

SEE SHEET C-3

NOTE: THE CROSS-SLOPE FOR THE DG PATH AND SIDEWALK MUST NOT EXCEED 1.5% AT ANY TIME.

NOTE: SEE LANDSCAPE PLANS FOR GRASS FIELD & BALL FIELD SECTIONS, FENCING AND TREE DESIGN

NOTE: SEE SHEET C-7 FOR STORM DRAIN DESIGN

RICK ENGINEERING COMPANY
 5620 FRIARS ROAD
 SAN DIEGO, CA 92110
 619-291-0707
 (FAX) 619-291-4165
 rickengineering.com
 San Diego Riverside - Orange - Sacramento - San Luis Obispo - Phoenix - Tucson - Denver

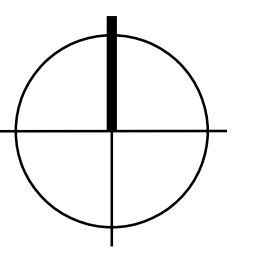
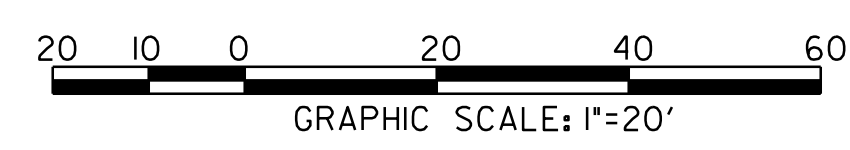

Karen S. Van Ert
 KAREN S. VAN ERT R.C.E. 56991 EXP. 6-30-2021

10-15-2019 DATE



REFERENCE NOTE FOR IRRIGATION ADDED, TREE WELL SYMBOL REMOVED AND LEGEND NOTES REVISED

ADDENDUM B

SEE SHEET C-2

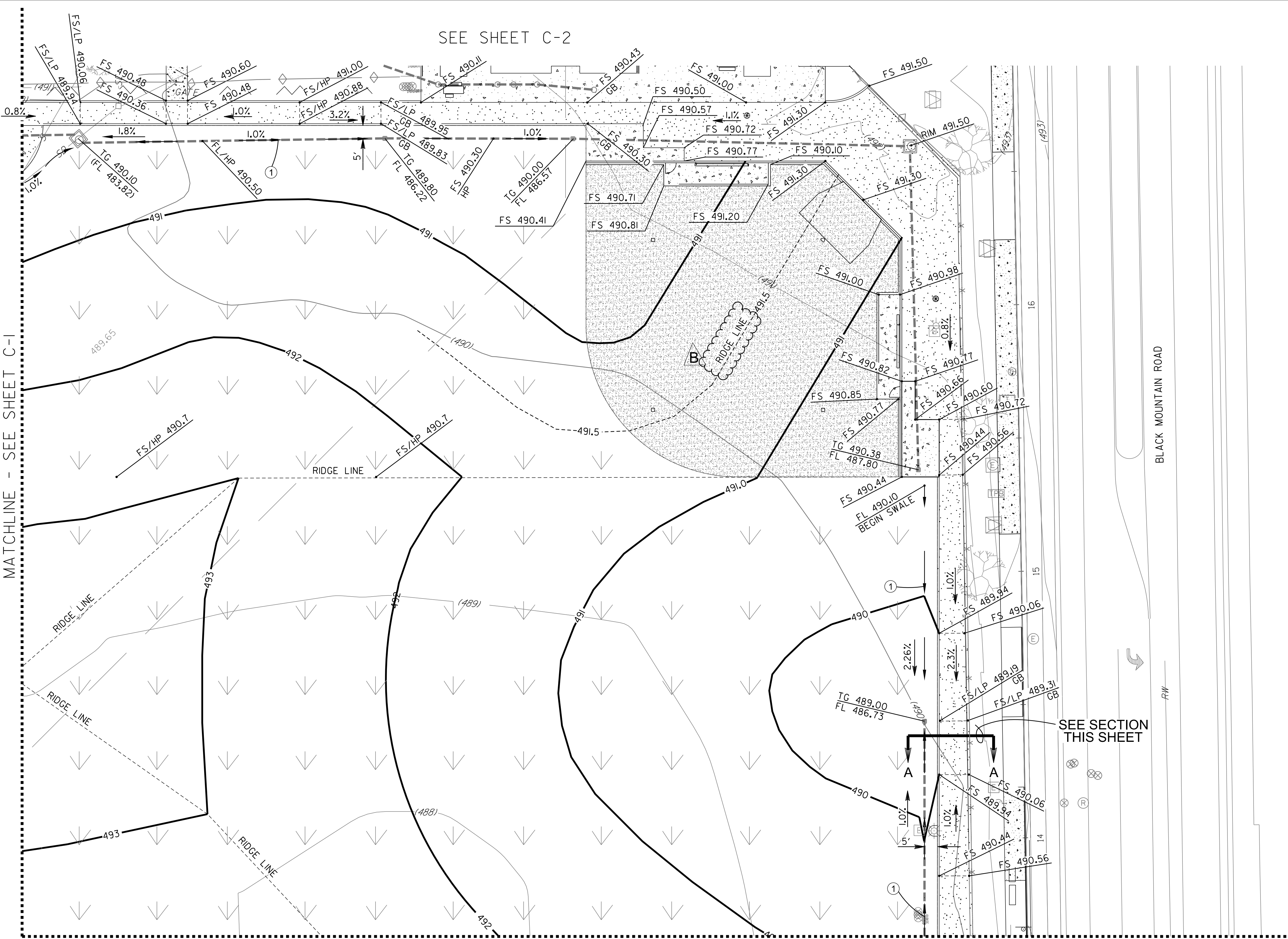

IDENTIFICATION STAMP
 DIV. OF THE STATE ARCHITECT
 APP. 04-118244 INC.
 REVIEWED FOR
 SS FLS ACS
 DATE: 02.14.2020

CONSTRUCTION LEGEND:

- DG-SEE LANDSCAPE PLANS
- CLAY INFILD
- GRASS/FIELD
- CONCRETE
- LANDSCAPE PLANTER

① GRASS SWALE PER DETAIL SHEET G-4
 ② BACKSTOP SEE SHEET L-7 FOR DETAIL

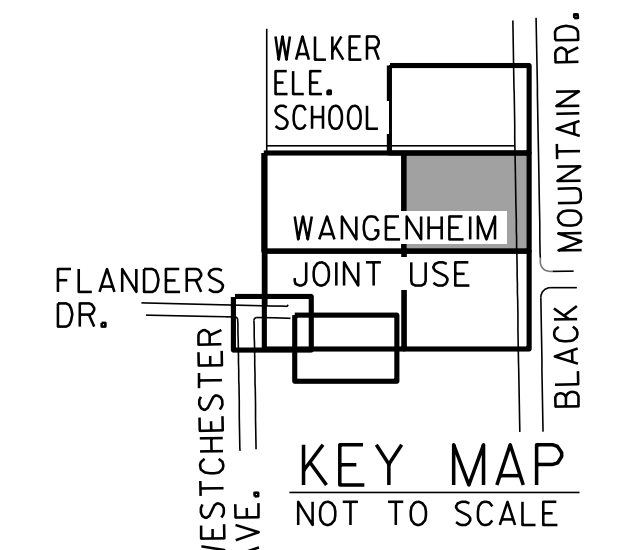
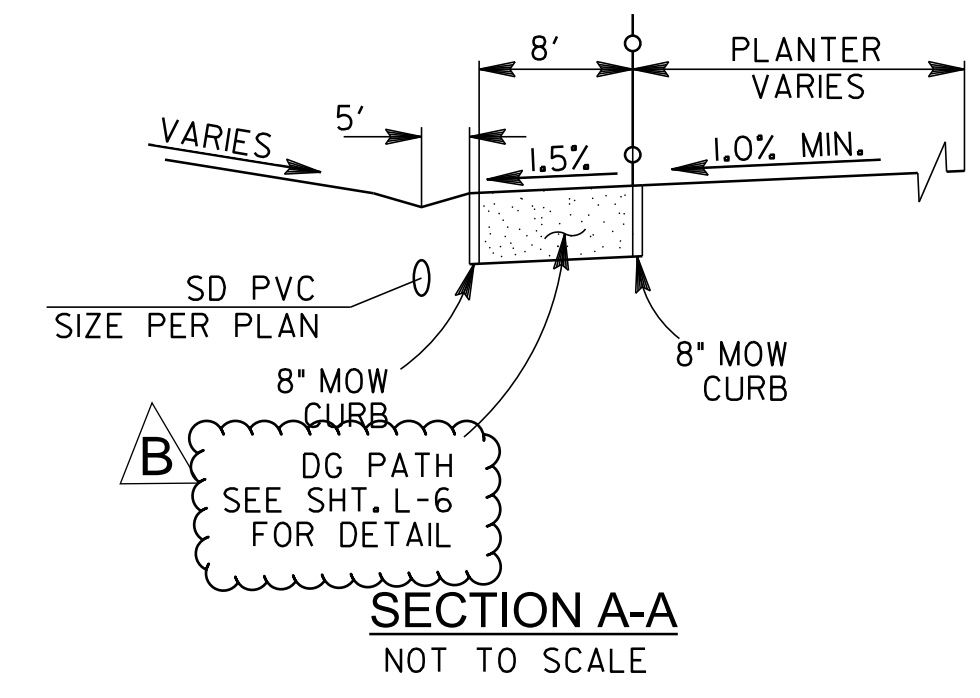

IMPORTANT NOTICE
 SECTION 4215/4217 OF THE GOVERNMENT CODE REQUIRES A DIG ALERT IDENTIFICATION NUMBER BE ISSUED BEFORE A "PERMIT TO EXCAVATE" WILL BE VALID. FOR YOUR DIG ALERT I.D. NUMBER, CALL UNDERGROUND SERVICE ALERT TOLL FREE 1-800-422-4133 AT LEAST TWO WORKING DAYS BEFORE YOU DIG.

WANGERHEIM NEIGHBORHOOD JOINT USE FACILITY
ROUGH GRADING PLANS

CITY OF SAN DIEGO, CALIFORNIA
 PUBLIC WORKS DEPARTMENT
 SHEET 17 OF 142 SHEETS

APPROVED:	10/13/2020	SUBMITTED BY: YOVANNA LEWIS
FOR CITY ENGINEER: JASON GRANI	DATE: 77208	PROJECT MANAGER
PRINT NAME: JASON GRANI	RCE#: 77208	CREATED BY: MEHDI RASHIDPOUR-HARISI
DESCRIPTION: ORIGINAL	BY: REC	DATE: 270-1731
ADDITIONUM B	BY: REC	DATE: 1/11/2021
		DATE FILMED: 1910-6291
		DATE COMPLETED: CCS83 COORDINATE
		DATE COMPLETED: 40846-17-D

NOTE: THE CROSS-SLOPE FOR THE DG PATH AND SIDEWALK MUST NOT EXCEED 1.5% AT ANY TIME.
 NOTE: SEE LANDSCAPE PLANS FOR GRASS FIELD & BALL FIELD SECTIONS, FENCING AND TREE DESIGN

NOTE: SEE SHEET C-9 FOR STORM DRAIN DESIGN
 NOTE: FOR ADDITIONAL FINE GRADING SEE SHEET C-12

EXISTING UTILITIES NOTE:
 ALL EXISTING UTILITIES SHOWN ON THESE PLANS ARE PLOTTED FROM RECORD DATA AT THEIR APPROXIMATE LOCATIONS. UNDERGROUND FACILITIES MAY EXIST WHICH HAVE NOT BEEN REPORTED OR ARE NOT OF RECORD. CONTRACTOR SHALL VERIFY THE LOCATION OF ALL PERTINENT UTILITIES IN THE FIELD PRIOR TO THE START OF CONSTRUCTION.

RICK ENGINEERING COMPANY
 5620 FRIARS ROAD
 SAN DIEGO, CA 92110
 619-291-0707
 (FAX) 619-291-4165
 J-17721
 rickengineering.com
 Riverside - Orange - Sacramento - San Luis Obispo - Phoenix - Tucson - Denver

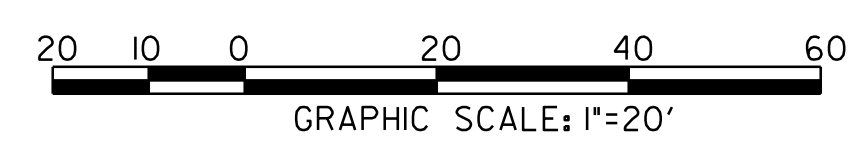

KAREN S. VAN ERT R.C.E. 56991 EXP. 6-30-2021



CONTRACTOR: DATE STARTED: 10/15/2019
 INSPECTOR: DATE COMPLETED:

REVISED CALL OUT IN SECTION A-A, UPDATE LEGEND NOTES AND ADD RIDGE LINE CALL OUT

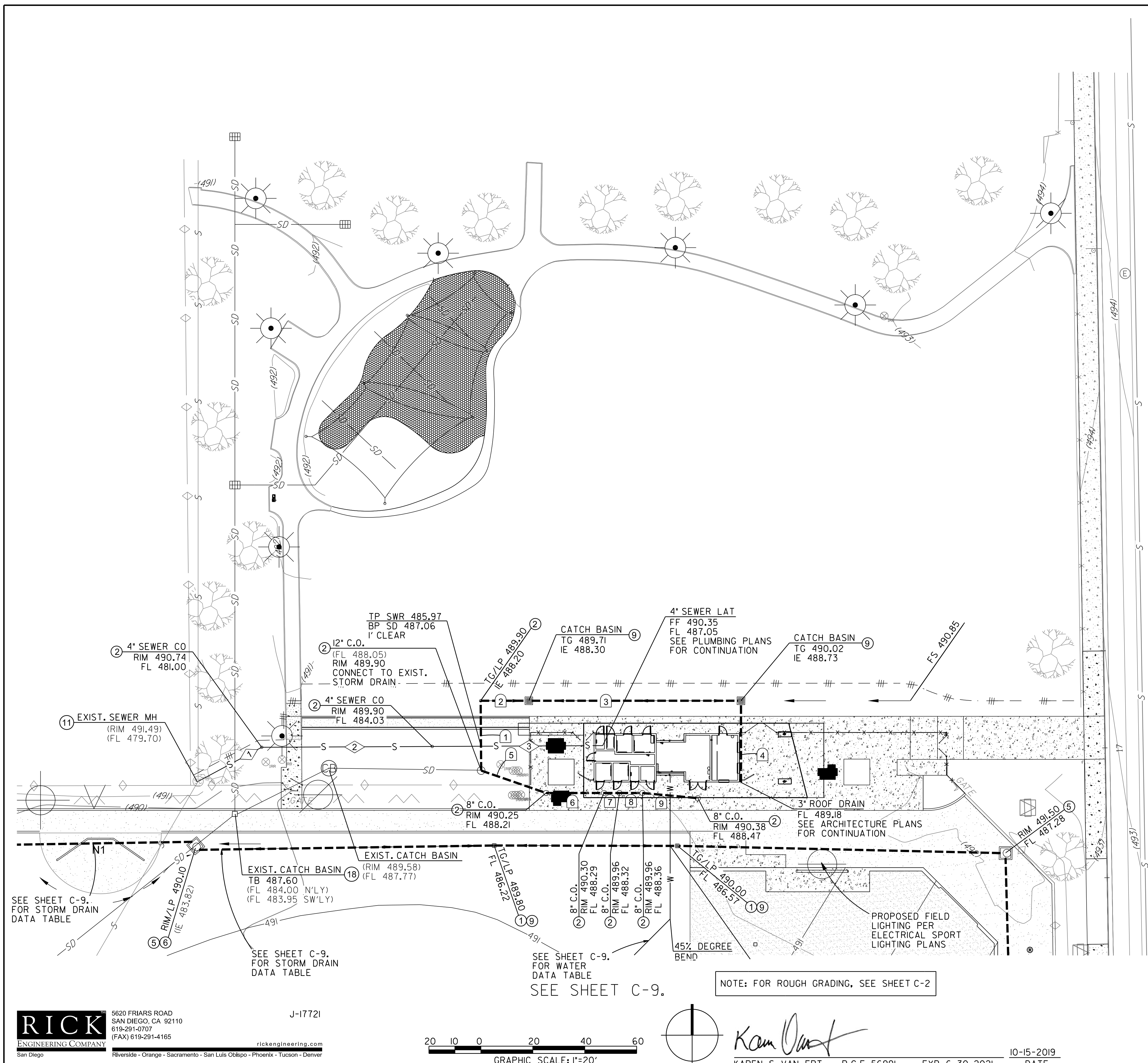

- CONSTRUCTION NOTES:**
- ① PROPOSED 24" NDS SQUARE BRASS GRATE
 - ② PROPOSED 12" CLEANOUT PER SDSW-101 SEE DETAIL ON SHEET C-26
 - ③ CONNECT PROPOSED TYPE I CATCH BASIN TO EXIST. 12" STORM DRAIN
 - ④ PROPOSED TYPE I CATCH BASIN PER D-29, SEE SHT. C-28
 - ⑤ PROPOSED TYPE A-4 CLEANOUT PER D-9, SEE SHT. C-28
 - ⑥ CONNECT PROPOSED TYPE A-4 CLEANOUT TO EXIST. 12" STORM DRAIN
 - ⑦ CONNECT PROPOSED STORM DRAIN TO EXIST. CATCH BASIN
 - ⑧ CONNECT TYPE I CATCH BASIN TO EXIST. 15" STORM DRAIN
 - ⑨ PROPOSED 24" X 24" CATCH BASIN
 - ⑩ FOR BASIN I CROSS SECTION SEE SHEET C-26
 - ⑪ CONNECT 4" SEWER LATERAL TO EXISTING SEWER MANHOLE
 - ⑫ SEE DETAIL SDSW-101 SHEET C-26
 - ⑬ SEE DETAIL SDSW-102 SHEET C-26
 - ⑭ SEE DETAIL SDSW-103 SHEET C-26
 - ⑮ SEE BMP CROSS-SECTION SHEET C-26
 - ⑯ 6" LANDSCAPE COBBLE (RIP-RAP) WITH 8" COBBLE ROCK, 4'W X 6'L
 - ⑰ DIP WATER UNDER PROPOSED STORM DRAIN
 - ⑱ EXISTING CATCH BASIN BURIED PER DEMO PLANS. SEE SHEET D-2 FOR DETAIL
 - ⑲ PROPOSED TRENCH RESURFACING PER SDG-107, SEE SHT. C-28
 - ⑳ PROPOSED TYPE B INLET PER STD. DWG SDD-116, SEE SHT. C-28

IDENTIFICATION STAMP
 DIV. OF THE STATE ARCHITECT
 APP. 04-118244 INC.
 REVIEWED FOR
 SS FLS ACS
 DATE: 02.14.2020

SEWER DATA				
NO.	DELTA OR BRG.	RADIUS	LENGTH	REMARKS
1	N61° 44' 30"E		28.19'	4" PVC @ 4.60%
2	N89° 43' 33"E		65.65'	4" PVC @ 4.60%
3	N89° 43' 33"E		65.65'	4" PVC @ 4.60%

STORM DRAIN DATA				
NO.	DELTA OR BRG.	RADIUS	LENGTH	REMARKS
1	N0° 24' 21"W		26.88'	8" PVC @ 0.5%
2	N90° 00' 00"E		17.47'	8" PVC @ 0.8%
3	N90° 00' 00"E		79.54'	8" PVC @ 0.5%
4	N00° 00' 00"E		30.36'	8" PVC @ 1.34%
5	S70° 56' 32"E		26.46'	8" PVC @ 0.5%
6	N90° 00' 00"E		22.28'	8" PVC @ 0.5%
7	N90° 00' 00"E		6.00'	8" PVC @ 0.5%
8	N90° 00' 00"E		8.84'	8" PVC @ 0.5%
9	S84° 38' 39"E		21.43'	8" PVC @ 0.5%

EXISTING UTILITIES NOTE:
 ALL EXISTING UTILITIES SHOWN ON THESE PLANS ARE PLOTTED FROM RECORD DATA AT THEIR APPROXIMATE LOCATIONS. UNDERGROUND FACILITIES MAY EXIST WHICH HAVE NOT BEEN REPORTED OR ARE NOT OF RECORD. CONTRACTOR SHALL VERIFY THE LOCATION OF ALL PERTINENT UTILITIES IN THE FIELD PRIOR TO THE START OF CONSTRUCTION.

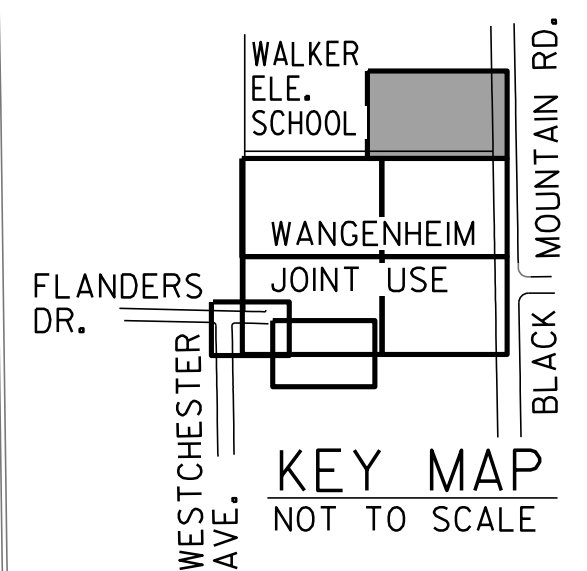

IMPORTANT NOTICE
 SECTION 4215/4217 OF THE GOVERNMENT CODE REQUIRES A DIG ALERT IDENTIFICATION NUMBER BE ISSUED BEFORE A 'PERMIT TO EXCAVATE' WILL BE VALID. FOR YOUR DIG ALERT I.D. NUMBER, CALL UNDERGROUND SERVICE ALERT TOLL FREE 1-800-422-4133 AT LEAST TWO WORKING DAYS BEFORE YOU DIG.

WANGENHEIM NEIGHBORHOOD JOINT USE FACILITY
UTILITY PLANS

CITY OF SAN DIEGO, CALIFORNIA
 PUBLIC WORKS DEPARTMENT
 SHEET 22 OF 142 SHEETS

APPROVED:	10/13/2020	SUBMITTED BY:	YOVANNA LEWIS
FOR CITY ENGINEER	DATE	PROJECT MANAGER	
JASON GRANI	77208	PROJECT ENGINEER	MEHDI RASHIDPOUR-HARISH
PRINT NAME	RCE#		
DESCRIPTION	BY	APPROVED	DATE
ORIGINAL	REC		1/11/2021
ADDENDUM B	REC		
			270-1731
			CCS27 COORDINATE
			1910-6291
			CCS83 COORDINATE
CONTRACTOR	DATE STARTED	INSPECTOR	DATE COMPLETED

RICK ENGINEERING COMPANY
 5620 FRIARS ROAD
 SAN DIEGO, CA 92110
 619-291-0707
 (FAX) 619-291-4165
 J-17721
 rickengineering.com
 Riverside - Orange - Sacramento - San Luis Obispo - Phoenix - Tucson - Denver

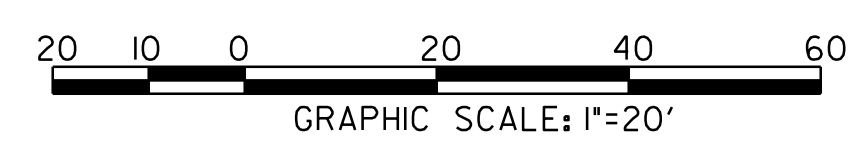

NOTE: FOR ROUGH GRADING, SEE SHEET C-2

Karen S. Van Ert
 KAREN S. VAN ERT R.C.E. 56991 EXP. 6-30-2021

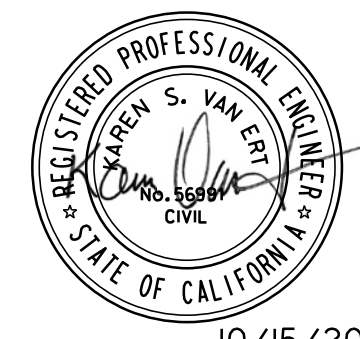

REVISOR: 10/15/2019
 REVISION: 5, 18 & 19

ADDENDUM B Page 20 of 56

MATCHLINE - SEE SHEET C-9

MATCHLINE - SEE SHEET C-10

CONSTRUCTION NOTES:

- 1 PROPOSED 24" NDS SQUARE BRASS GRATE
- 2 PROPOSED 12" CLEANOUT PER SDSW-101 SEE DETAIL ON SHEET C-26
- 3 CONNECT PROPOSED TYPE I CATCH BASIN TO EXIST. 12" STORM DRAIN
- 4 PROPOSED TYPE I CATCH BASIN PER D-29, SEE SHT. C-2
- 5 PROPOSED TYPE A-1 CLEANOUT PER D-3, SEE SHT. C-28
- 6 CONNECT PROPOSED TYPE A-4 CLEANOUT TO EXIST. 12" STORM DRAIN
- 7 CONNECT PROPOSED STORM DRAIN TO EXIST. CATCH BASIN
- 8 CONNECT TYPE I CATCH BASIN TO EXIST. 15" STORM DRAIN
- 9 PROPOSED 24" X 24" CATCH BASIN
- 10 FOR BASIN I CROSS SECTION SEE SHEET C-26
- 11 CONNECT 4" SEWER LATERAL TO EXISTING SEWER MANHOLE
- 12 SEE DETAIL SDSW-101 SHEET C-26
- 13 SEE DETAIL SDSW-102 SHEET C-26
- 14 SEE DETAIL SDSW-103 SHEET C-26
- 15 SEE BMP CROSS-SECTION SHEET C-26
- 16 6" LANDSCAPE COBBLE (RIP-RAP) WITH 8" COBBLE ROCK, 4' W X 6' L
- 17 DIP WATER UNDER PROPOSED STORM DRAIN
- 18 EXISTING CATCH BASIN BURIED PER DEMO PLANS. SEE SHEET D-5 OR DETAIL
- 19 PROPOSED TRENCH RESURFACING PER SDG-107, SEE SHT. C-28
- 20 PROPOSED TYPE B INLET PER STD. DWG. SDD-116, SEE SHT. C-28

IDENTIFICATION STAMP
 DIV. OF THE STATE ARCHITECT
 APP. 04-118244 INC.
 REVIEWED FOR
 SS FLS ACS
 DATE: 02.14.2020

STORM DRAIN DATA				
NO.	DELTA OR BRG.	RADIUS	LENGTH	REMARKS
1	N62° 39' 04" W		72.05'	I2" PVC @ 0.5%
2	S89° 59' 36" W		132.76'	I2" PVC @ 0.5%
3	N00° 03' 46" W		21.32'	I2" PVC @ 0.5%
4	N00° 00' 00" E		80.67'	I2" PVC @ 0.5%
5	N00° 00' 00" E		21.66'	I2" PVC @ 4.8%
6	N00° 00' 00" E		10.54'	I2" PVC @ 0.5%
7	S05° 59' 51" E		184.97'	I2" PVC @ 0.5%
8	N00° 00' 00" E		99.77'	I2" PVC @ 0.5%
9	N00° 00' 00" E		69.19'	I2" PVC @ 0.5%

WATER DATA				
NO.	DELTA OR BRG.	RADIUS	LENGTH	REMARKS
1	Δ = 14° 33' 46"	350.00'	88.96'	3" PVC

EXISTING UTILITIES NOTE:
 ALL EXISTING UTILITIES SHOWN ON THESE PLANS ARE PLOTTED FROM RECORD DATA AT THEIR APPROXIMATE LOCATIONS. UNDERGROUND FACILITIES MAY EXIST WHICH HAVE NOT BEEN REPORTED OR ARE NOT OF RECORD. CONTRACTOR SHALL VERIFY THE LOCATION OF ALL PERTINENT UTILITIES IN THE FIELD PRIOR TO THE START OF CONSTRUCTION.



CALL 811 BEFORE YOU DIG

IMPORTANT NOTICE
 SECTION 4215/4217 OF THE GOVERNMENT CODE REQUIRES A DIG ALERT IDENTIFICATION NUMBER BE ISSUED BEFORE A "PERMIT TO EXCAVATE" WILL BE VALID. FOR YOUR DIG ALERT I.D. NUMBER, CALL UNDERGROUND SERVICE ALERT TOLL FREE 1-800-422-4133 AT LEAST TWO WORKING DAYS BEFORE YOU DIG.

C-11

WANGENHEIM NEIGHBORHOOD JOINT USE FACILITY

UTILITY PLAN

CITY OF SAN DIEGO, CALIFORNIA PUBLIC WORKS DEPARTMENT SHEET 25 OF 142 SHEETS		WBS S-15007
APPROVED: <i>[Signature]</i> FOR CITY ENGINEER JASON GRANI PRINT NAME	DATE: 10/13/2020 77208 RCE#	SUBMITTED BY: YOVANNA LEWIS PROJECT MANAGER CREATED BY: MEHDI RASHIDPOUR-HARISI PROJECT ENGINEER
DESCRIPTION	BY	APPROVED
ORIGINAL	REC	
ADDENDUM B	REC	
		DATE FILMED
		1/11/2021
		DATE STARTED
		DATE COMPLETED
CONTRACTOR INSPECTOR		40846-25-D

CAUTION: 13" HP GAS!
 CONTRACTOR TO VERIFY EXACT LOCATION AND MUST NOTIFY SDG&E IN ADVANCE PRIOR TO EXCAVATION. SDG&E STAND BY REQUIRED.

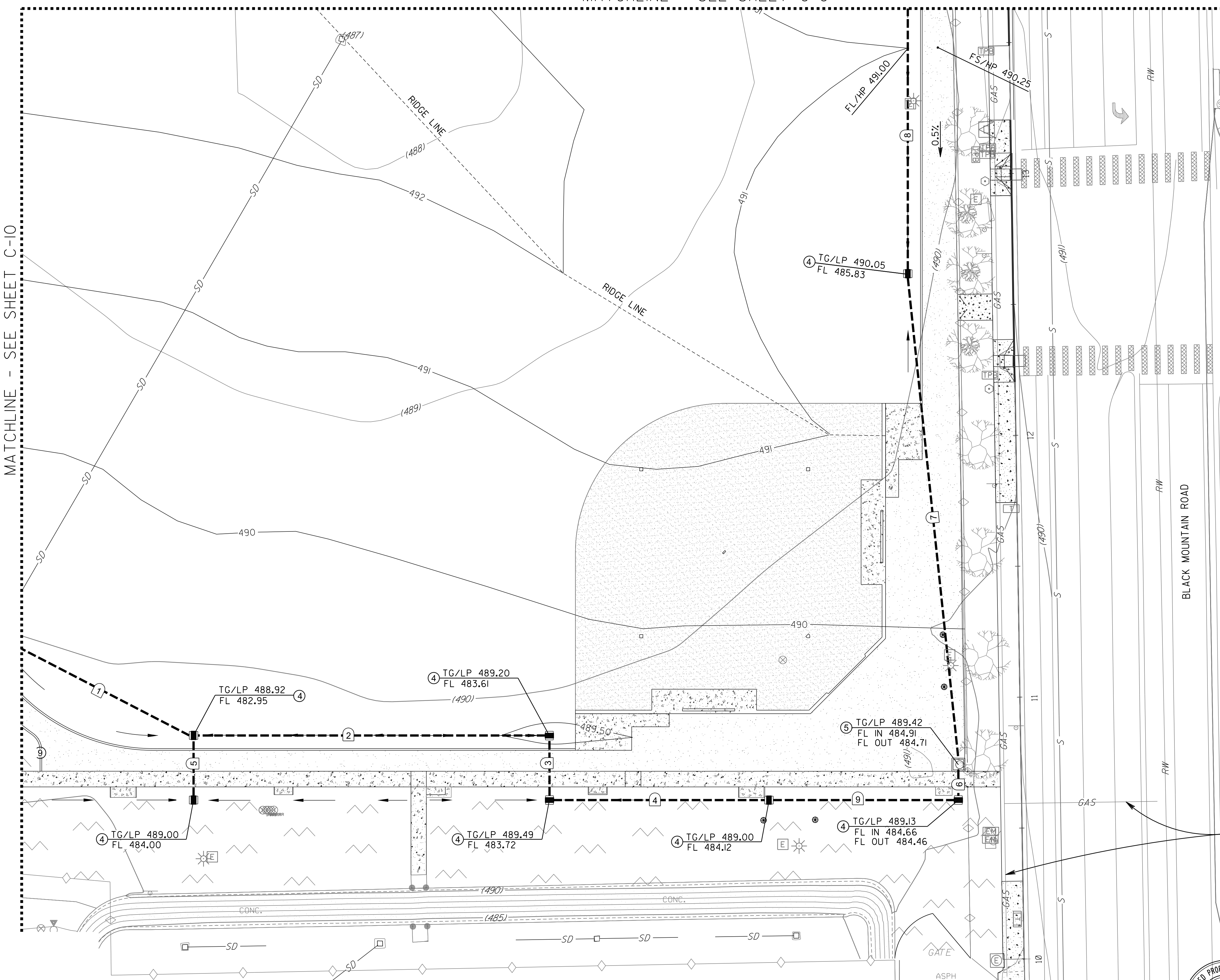

RICK ENGINEERING COMPANY
 5620 FRIARS ROAD
 SAN DIEGO, CA 92110
 619-291-0707
 (FAX) 619-291-4165
 rickengineering.com
 Riverside - Orange - Sacramento - San Luis Obispo - Phoenix - Tucson - Denver

NOTE: FOR ROUGH GRADING, SEE SHEET C-5

20 10 0 20 40 60
 GRAPHIC SCALE: 1"=20'

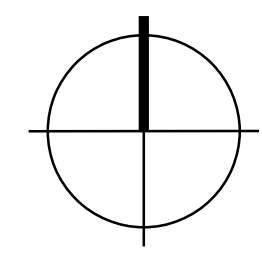

[Signature]
 KAREN S. VAN ERT
 R.C.E 56991
 EXP. 6-30-2021

10-15-2019
 DATE

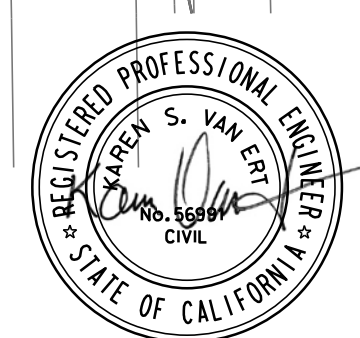

REVISOR: 10/15/2019
 REVISION: 5, 18 & 19

ADDENDUM B

IDENTIFICATION STAMP
 DIV. OF THE STATE ARCHITECT
 APP. 04-118244 INC.
 REVIEWED FOR
 SS FLS ACS
 DATE: 02.14.2020

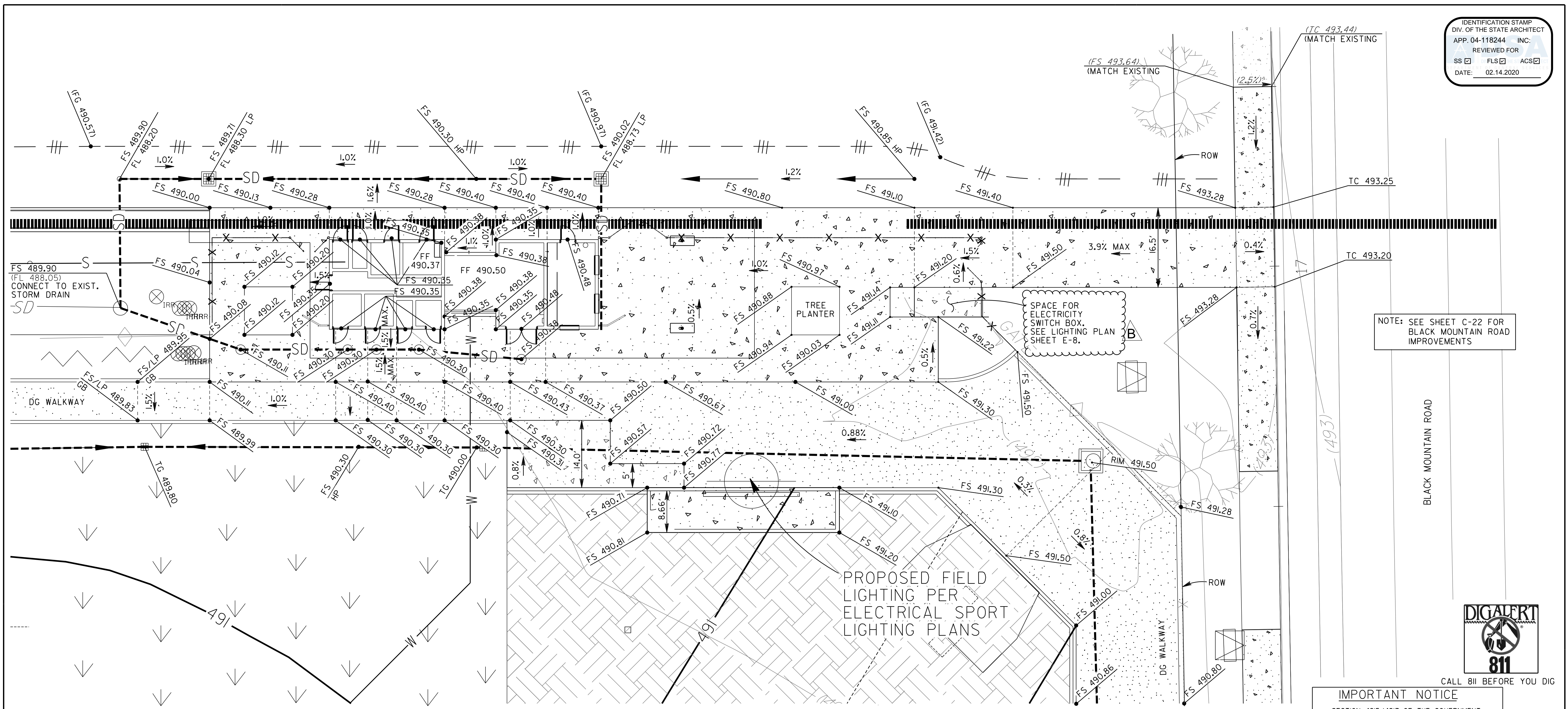

NOTE: SEE SHEET C-22 FOR
 BLACK MOUNTAIN ROAD
 IMPROVEMENTS

PROPOSED FIELD
 LIGHTING PER
 ELECTRICAL SPORT
 LIGHTING PLANS



IMPORTANT NOTICE
 SECTION 4215/4217 OF THE GOVERNMENT
 CODE REQUIRES A DIG ALERT IDENTIFICATION
 NUMBER BE ISSUED BEFORE A
 "PERMIT TO EXCAVATE" WILL BE VALID.
 FOR YOUR DIG ALERT I.D. NUMBER, CALL
 UNDERGROUND SERVICE ALERT
 TOLL FREE 1-800-422-4133
 AT LEAST TWO WORKING DAYS BEFORE YOU DIG.

C-12

CONSTRUCTION NOTES:

- PROPOSED FIELD DIRT
- PROPOSED DG PATH
- PROPOSED 4" PCC PER
TYPICAL SIDEWALK DETAIL ON SHEET G-4
- PROPOSED GRASS
- EXISTING CONCRETE



NOTE: FOR FENCING AND BACKSTOP
 DETAILS, SEE LANDSCAPE PLANS

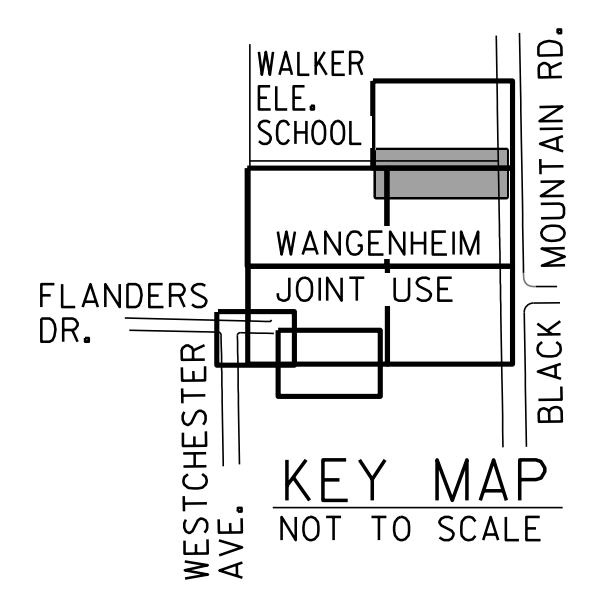

RICK
 ENGINEERING COMPANY
 5620 FRIARS ROAD
 SAN DIEGO, CA 92110
 619-291-0707
 (FAX) 619-291-4165
 rickengineering.com
 J-17721

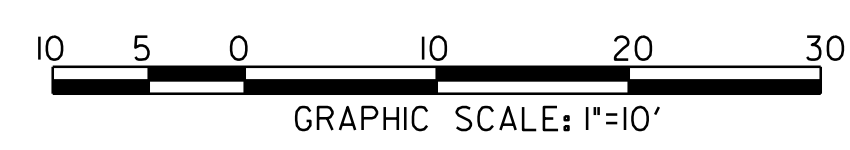

Karen S. Van Ert
 KAREN S. VAN ERT
 R.C.E. 56991
 EXP. 6-30-2021

10-15-2019
 DATE

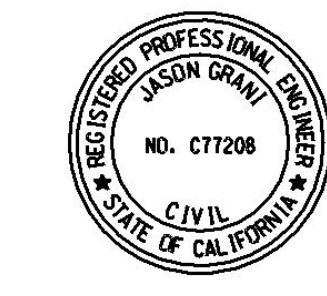

CITY OF SAN DIEGO, CALIFORNIA PUBLIC WORKS DEPARTMENT SHEET 26 OF 142 SHEETS		WBS S-15007
APPROVED: FOR CITY ENGINEER JASON GRANI PRINT NAME	10/13/2020 DATE 77208 RCE#	SUBMITTED BY: YOVANNA LEWIS PROJECT MANAGER
DESCRIPTION	BY	APPROVED
ORIGINAL	REC	DATE
ADDENDUM B	REC	DATE
DATE STARTED		DATE FILMED
DATE COMPLETED		
CONTRACTOR		270-1731
INSPECTOR		CCS27 COORDINATE
		1910-6291
		CCS83 COORDINATE
		40846-26-D

B LIGHTING PLAN NOTE REVISED

ADDENDUM B

IDENTIFICATION STAMP
 DIV. OF THE STATE ARCHITECT
 APP. 04-118244 INC.
 REVIEWED FOR
 SS FLS ACS
 DATE: 02.14.2020

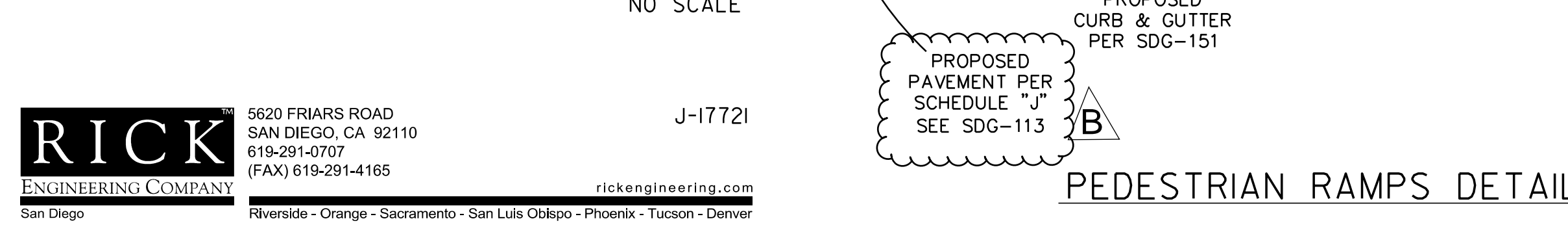
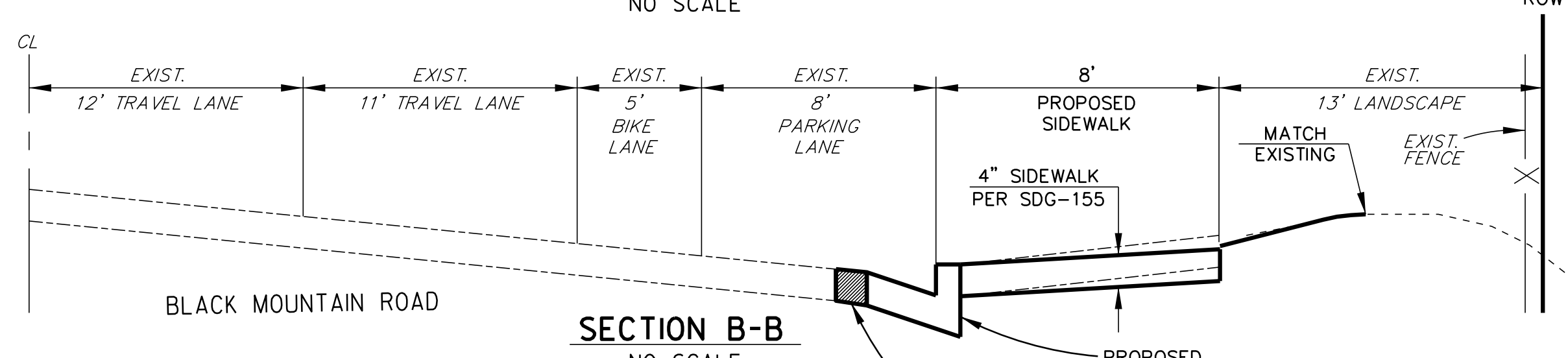
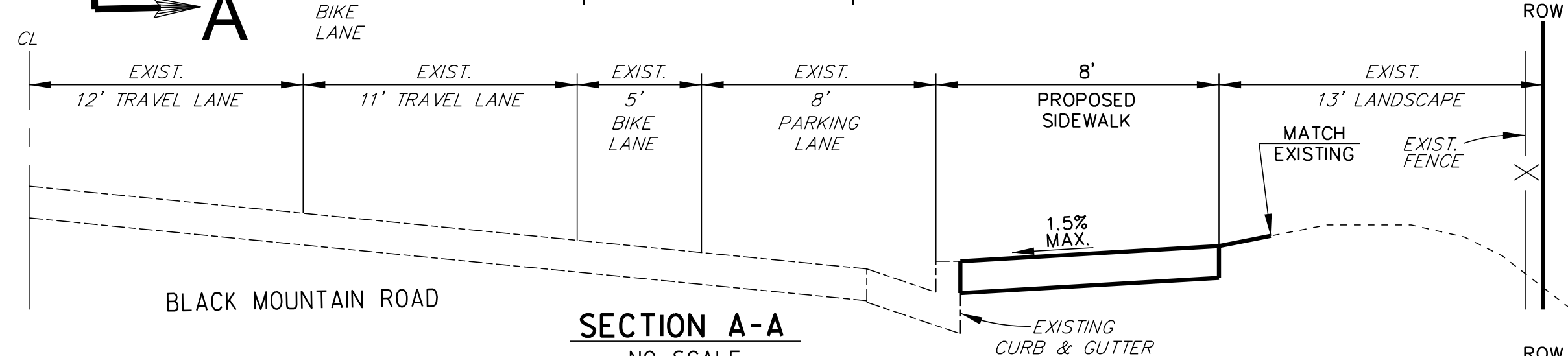
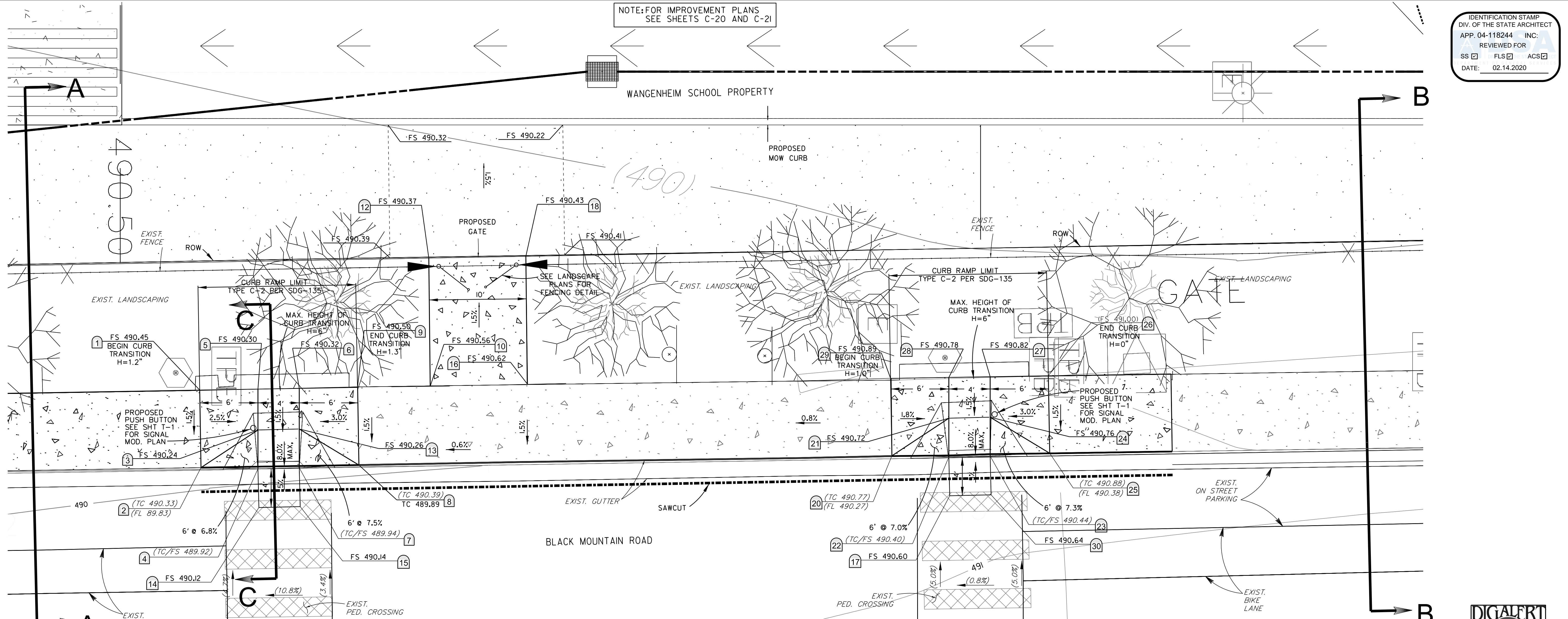

COORDINATE DATA TABLE

POINT	NORTHING	EASTING
1	1,911,750.72	6,293,310.55
2	1,911,750.86	6,293,318.55
3	1,911,756.73	6,293,318.52
4	1,911,756.73	6,293,314.67
5	1,911,756.73	6,293,310.67
6	1,911,760.99	6,293,310.57
7	1,911,760.99	6,293,318.57
8	1,911,767.13	6,293,318.28
9	1,911,766.98	6,293,310.28
10	1,911,770.48	6,293,310.22

COORDINATE DATA TABLE

POINT	NORTHING	EASTING
12	1,911,774.31	6,293,296.81
13	1,911,760.99	6,293,314.57
14	1,911,756.82	6,293,322.67
15	1,911,761.08	6,293,322.57
16	1,911,784.48	6,293,309.98
17	1,911,828.02	6,293,321.45
18	1,911,784.31	6,293,296.68
20	1,911,822.05	6,293,317.33

COORDINATE DATA TABLE

POINT	NORTHING	EASTING
21	1,911,827.92	6,293,313.45
22	1,911,827.92	6,293,317.45
23	1,911,832.18	6,293,317.35
24	1,911,832.18	6,293,313.35
25	1,911,838.32	6,293,317.06
26	1,911,838.18	6,293,309.07
27	1,911,832.18	6,293,309.35
28	1,911,827.92	6,293,309.45
29	1,911,821.92	6,293,309.33
30	1,911,832.28	6,293,321.35

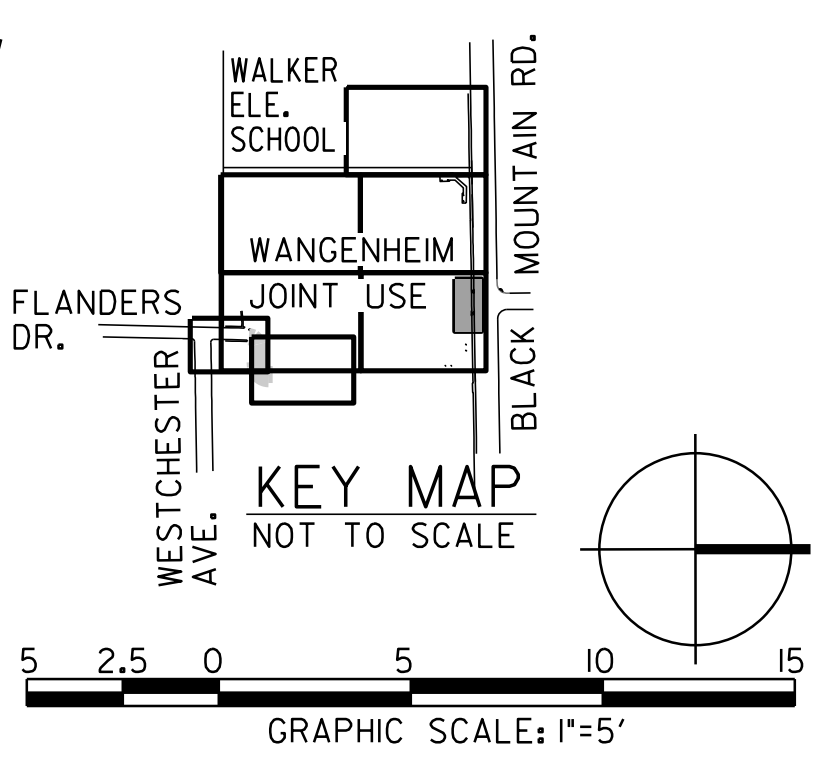
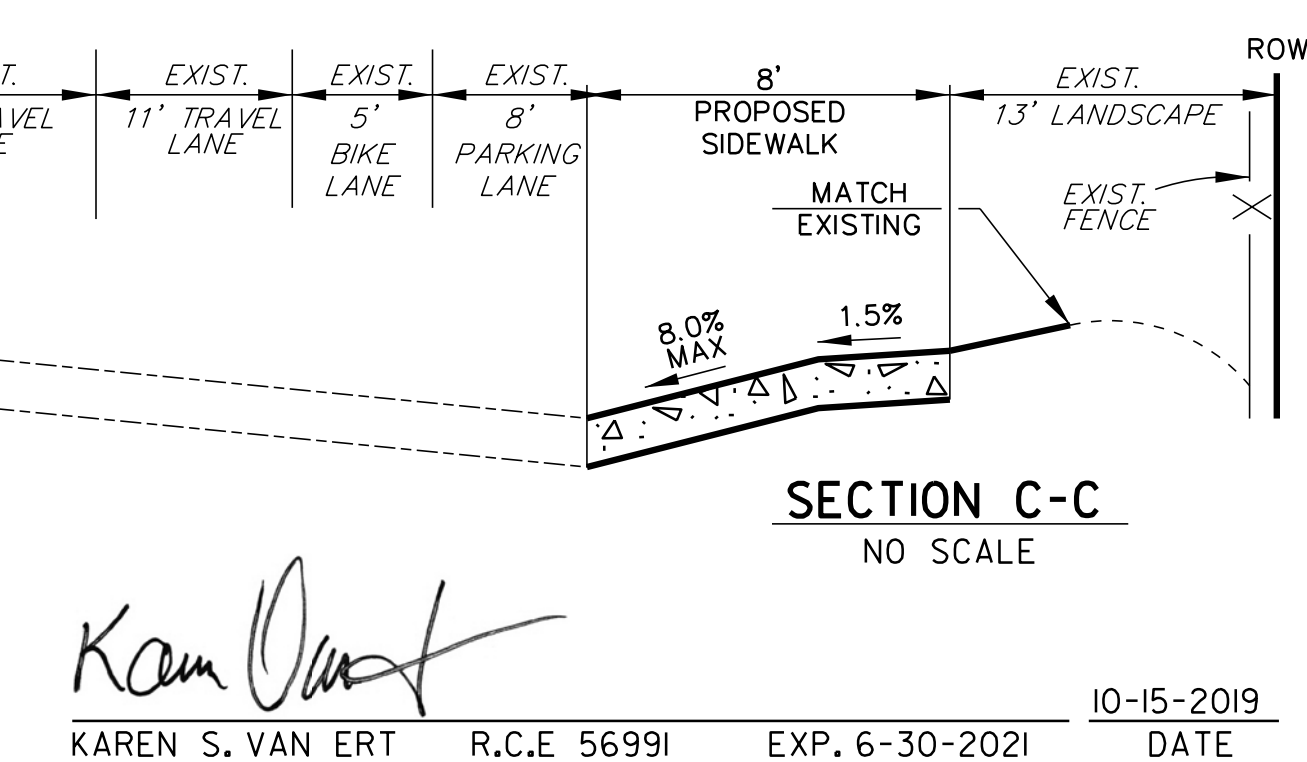

IMPORTANT NOTICE
 SECTION 4215/4217 OF THE GOVERNMENT CODE REQUIRES A DIG ALERT IDENTIFICATION NUMBER BE ISSUED BEFORE A 'PERMIT TO EXCAVATE' WILL BE VALID. FOR YOUR DIG ALERT I.D. NUMBER, CALL UNDERGROUND SERVICE ALERT TOLL FREE 1-800-422-4133 AT LEAST TWO WORKING DAYS BEFORE YOU DIG.

WANGENHEIM NEIGHBORHOOD JOINT USE FACILITY
CURB RAMPS AND DETAILS

CITY OF SAN DIEGO, CALIFORNIA PUBLIC WORKS DEPARTMENT SHEET 28 OF 142 SHEETS		WBS S-15007
APPROVED: JASON GRANI FOR CITY ENGINEER PRINT NAME	DATE: 10/13/2020 77208	SUBMITTED BY: YOVANNA LEWIS PROJECT MANAGER
DESCRIPTION BY	APPROVED DATE FILMED	CREATED BY: MEHDI RASHIDPOUR-HARISI PROJECT ENGINEER
ORIGINAL REC	1/11/2021	270-1731 CCS27 COORDINATE
ADDENDUM B REC		1910-6291 CCS83 COORDINATE
DATE STARTED		40846-28-D
DATE COMPLETED		

RICK ENGINEERING COMPANY
 5620 FRIARS ROAD
 SAN DIEGO, CA 92110
 619-291-0707
 (FAX) 619-291-4165
 J-17721
 rickengineering.com
 Riverside - Orange - Sacramento - San Luis Obispo - Phoenix - Tucson - Denver



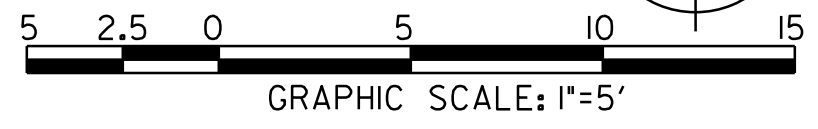

Karen S. Van Ert
 KAREN S. VAN ERT R.C.E 56991 EXP. 6-30-2021
 DATE 10-15-2019

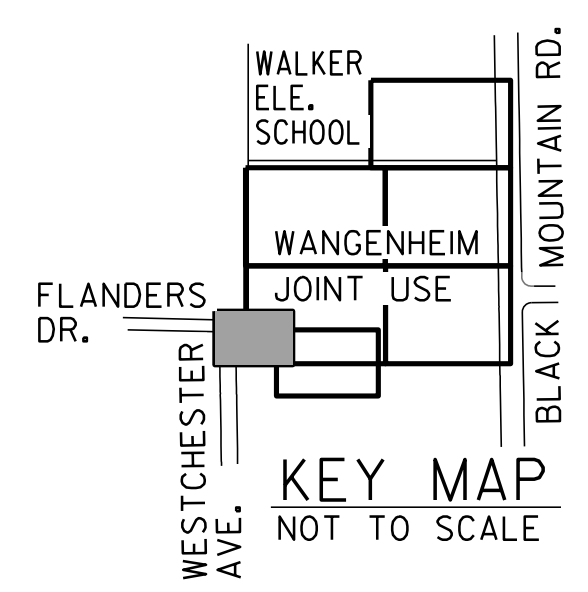

CONTRACTOR INSPECTOR

IDENTIFICATION STAMP
 DIV. OF THE STATE ARCHITECT
 APP. 04-118244 INC.
 REVIEWED FOR
 SS FLS ACS
 DATE: 02.14.2020



-  PROPOSED ASPHALT PER SCHEDULE J
-  PROPOSED CONCRETE DITCH
-  PROPOSED SLURRY SEAL
-  PROPOSED ASPHALT
-  SAWCUT LINE

CURB DATA				
NO.	DELTA OR BRG.	RADIUS	LENGTH	REMARKS
1	N88° 44'20"W		5.00'	TRANSITION CURB
2	N88° 44'20"W		4.00'	ZERO CURB
3	N88° 34'07"W		5.00'	TRANSITION CURB
4	N88° 21'02"W		13.77'	6' CURB & GUTTER
5	N87° 10'06"W		19.99'	6' CURB & GUTTER
6	N88° 43'19"W		4.00'	6' CURB & GUTTER
7	N88° 43'39"W		5.98'	TRANSITION CURB
8	N88° 43'19"W		4.00'	ZERO CURB
9	N88° 42'55"W		8.02'	TRANSITION CURB
10	N88° 37'08"W		3.93'	6' CURB & GUTTER



CALL 811 BEFORE YOU DIG

IMPORTANT NOTICE
 SECTION 4215/4217 OF THE GOVERNMENT CODE REQUIRES A DIG ALERT IDENTIFICATION NUMBER BE ISSUED BEFORE A "PERMIT TO EXCAVATE" WILL BE VALID. FOR YOUR DIG ALERT I.D. NUMBER, CALL UNDERGROUND SERVICE ALERT TOLL FREE 1-800-422-4133 AT LEAST TWO WORKING DAYS BEFORE YOU DIG.

C-20

WANGENHEIM NEIGHBORHOOD JOINT USE FACILITY

IMPROVEMENT PLANS FLANDERS DRIVE

CITY OF SAN DIEGO, CALIFORNIA
 PUBLIC WORKS DEPARTMENT
 SHEET 34 OF 142 SHEETS

WBS S-15007

APPROVED: 	10/13/2020	SUBMITTED BY: YOVANNA LEWIS
FOR CITY ENGINEER: JASON GRANI	DATE: 77208	PROJECT MANAGER
PRINT NAME: JASON GRANI	RCE#	CREATED BY: MEHDI RASHIDPOUR-HARISH
DESCRIPTION: ORIGINAL	BY: REC	DATE: 1/11/2021
ADDENDUM B	BY: REC	DATE: 1/11/2021
		270-1731
		CCS27 COORDINATE
		1910-6291
		CCS83 COORDINATE

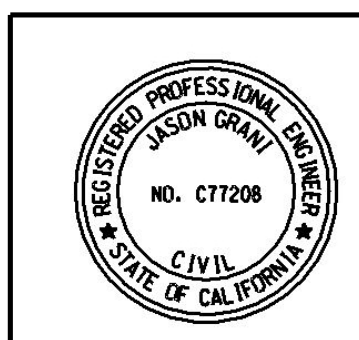

CONTRACTOR INSPECTOR

DATE STARTED: 10/15/2019
 DATE COMPLETED: 10/15/2019

40846-34-D

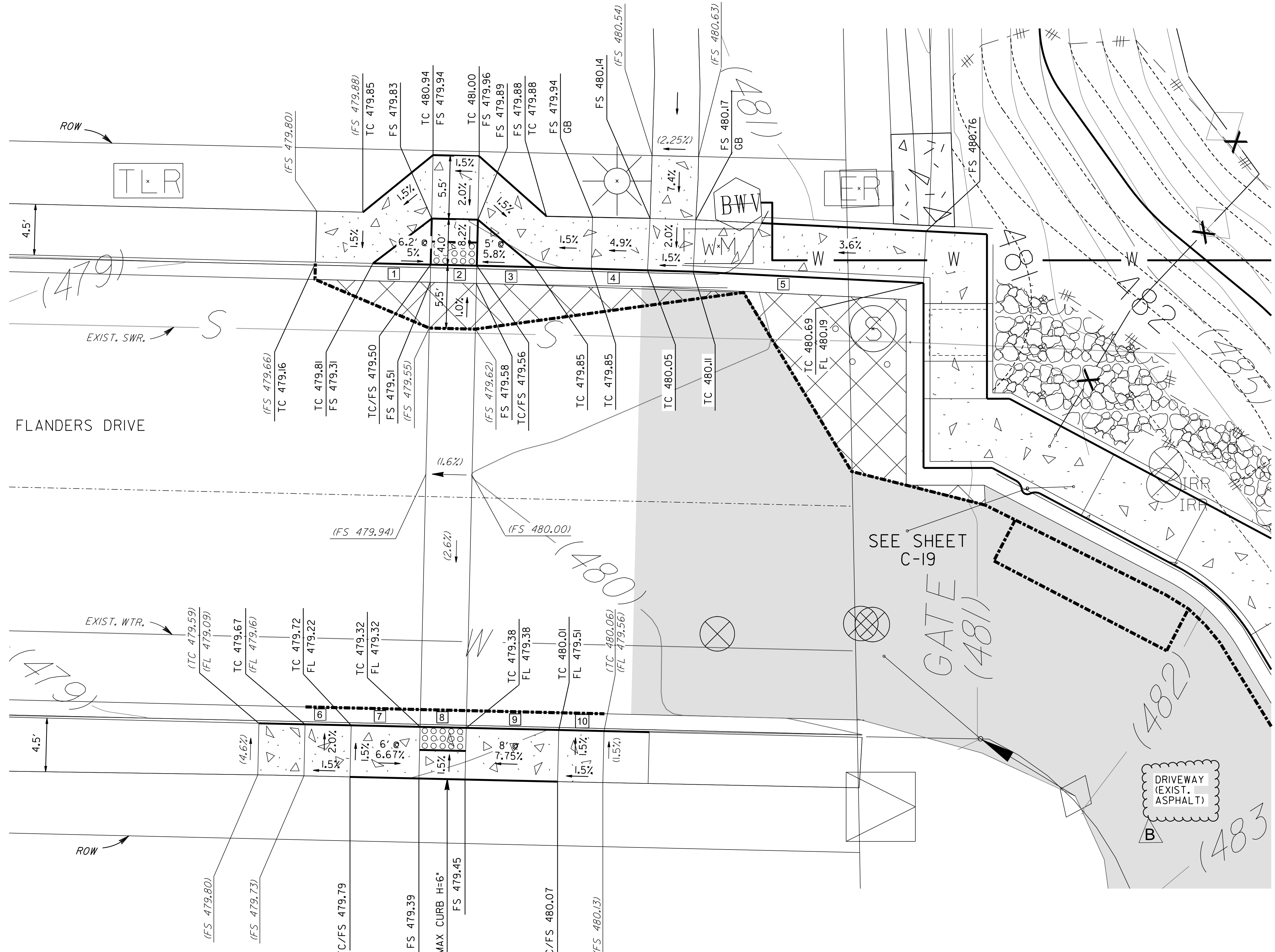

RICK ENGINEERING COMPANY
 5620 FRIARS ROAD
 SAN DIEGO, CA 92110
 619-291-0707
 (FAX) 619-291-4165
 rickengineering.com
 San Diego Riverside - Orange - Sacramento - San Luis Obispo - Phoenix - Tucson - Denver

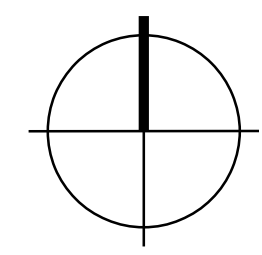
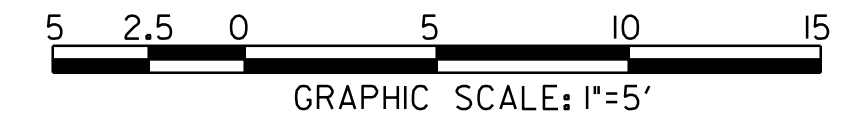

 KAREN S. VAN ERT
 R.C.E. 56991
 EXP. 6-30-2021

10-15-2019
 DATE



EXIST. DRIVEWAY NOTE ADDED

ADDENDUM B

IDENTIFICATION STAMP
 DIV. OF THE STATE ARCHITECT
 APP. 04-118244 INC.
 REVIEWED FOR
 SS FLS ACS
 DATE: 02.14.2020

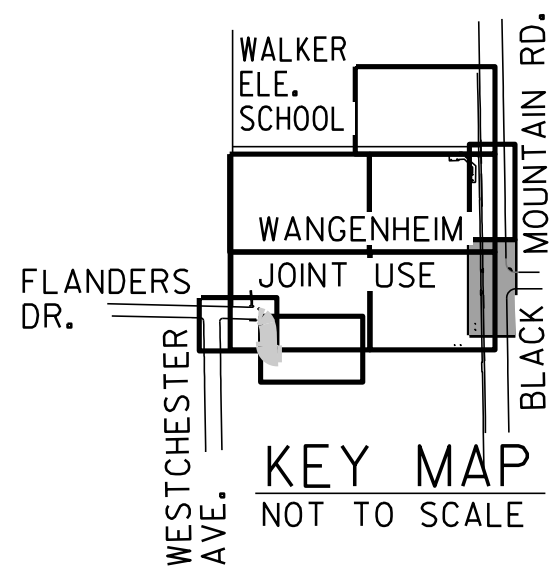

- IMPROVEMENT NOTES:
- ① INSTALL SIDEWALK TO MATCH EXISTING WIDTH PER SDG-155
 - ② INSTALL NEW SIDEWALK PER SDG-155, WIDTH PER PLAN
 - ③ PROTECT EXISTING CURB & GUTTER IN PLACE
 - ④ ADJUST EXISTING TELEPHONE VAULT TO FINISH GRADE
 - ⑤ PROTECT EXISTING TRAFFIC SIGN TO FINISH GRADE. ENSURE 4" MINIMUM PATH CLEARANCE AND 7" MINIMUM SIGN HEIGHT CLEARANCE
 - ⑥ PROTECT EXISTING COX COMMUNICATION MANHOLE IN PLACE
 - ⑦ PROTECT EXISTING CATHODIC PROTECTION AND SDG&E MANHOLE IN PLACE
 - ⑧ PROTECT EXISTING PEDESTRIAN CROSSING SIGN IN PLACE
 - ⑨ PROTECT EXISTING STREET LIGHT IN PLACE
 - ⑩ ADJUST EXISTING TRAFFIC PULL BOX TO FINISH GRADE
 - ⑪ INSTALL "TYPE C-2" CURB RAMP PER SDG-135 (SEE DETAIL SHEET C-14)
 - ⑫ INSTALL "TYPE G" CURB AND GUTTER PER SDG-151
 - ⑬ PROTECT EXISTING TRAFFIC SIGNS IN PLACE
 - ⑭ FOR ACCESSIBILITY PATH DETAIL, SEE SHEET C-14
 - ⑮ PROTECT EXISTING SDG&E MANHOLE IN PLACE
 - ⑯ ADJUST EXISTING ELECTRICAL TRANSFORMER TO FINISH GRADE
 - ⑰ PROTECT EXISTING BUS STOP AT FINISH GRADE. CONTRACTOR TO ENSURE 4" MINIMUM PATH CLEARANCE AND 7" MINIMUM SIGN HEIGHT CLEARANCES. SEE NOTES ON SHEET G-04. CONTRACTOR TO PROVIDE NEW POST, AND MTS TO PROVIDE BUS STOP SIGN. CONTRACTOR TO COORDINATE WITH MTS.
 - ⑱ REPLACE EXISTING BUS STOP BENCHES AFTER NEW SIDEWALK IS INSTALLED
 - ⑲ MATCH EXISTING CURB & GUTTER PER SDG-151
 - ⑳ EXISTING VALVES TO REMAIN
 - ㉑ ADJUST EXISTING AIR RELEASE VALVE TO FINISH GRADE
 - ㉒ ADJUST EXISTING CORROSION TEST STATION TO FINISH GRADE
 - ㉓ PROTECT EXISTING ELECTRICAL TRANSFORMER IN PLACE
 - ㉔ FOR PATHWAY FINE GRADING, SEE SHEET C-12
 - ㉕ MATCH EXIST. SIDEWALK OR EXTEND TO NEAREST SIDEWALK JOINT FOR CLEAN CONSTRUCTION OF SIDEWALK
 - ㉖ PROTECT EXISTING SIDEWALK
 - ㉗ PROTECT EXISTING TRAFFIC PULL BOX IN PLACE

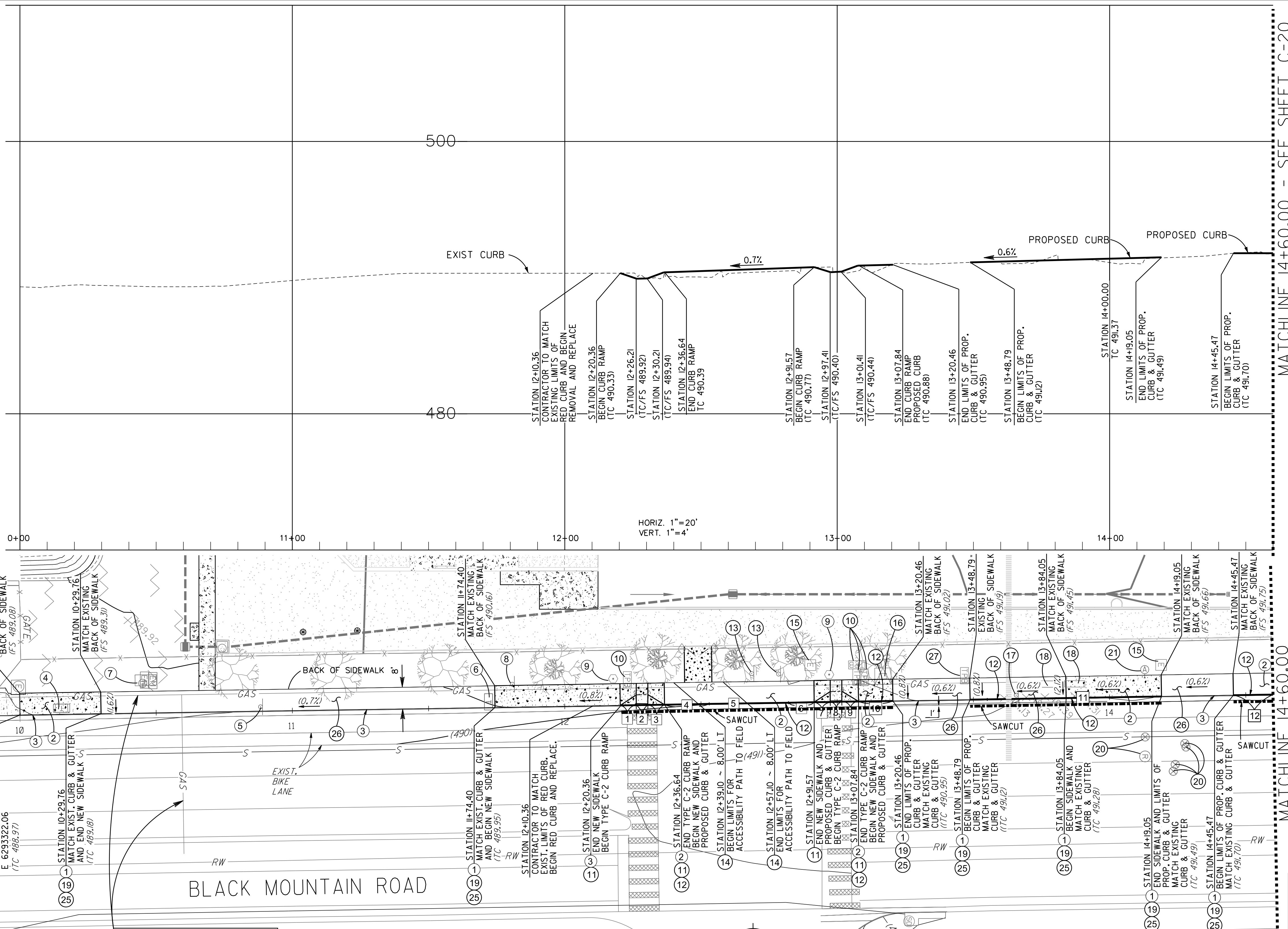

EXISTING UTILITIES NOTE:
 ALL EXISTING UTILITIES SHOWN ON THESE PLANS ARE PLOTTED FROM RECORD DATA AT THEIR APPROXIMATE LOCATIONS. UNDERGROUND FACILITIES MAY EXIST WHICH HAVE NOT BEEN REPORTED OR ARE NOT OF RECORD. CONTRACTOR SHALL VERIFY THE LOCATION OF ALL PERTINENT UTILITIES IN THE FIELD PRIOR TO THE START OF CONSTRUCTION.

IMPORTANT NOTICE
 SECTION 4215/4217 OF THE GOVERNMENT CODE REQUIRES A DIG ALERT IDENTIFICATION NUMBER BE ISSUED BEFORE A "PERMIT TO EXCAVATE" WILL BE VALID. FOR YOUR DIG ALERT I.D. NUMBER, CALL UNDERGROUND SERVICE ALERT TOLL FREE 1-800-422-4133 AT LEAST TWO WORKING DAYS BEFORE YOU DIG.

NO.	DELTA OR BRG.	RADIUS	LENGTH	REMARKS
1	N00°58'01"W	5.87'	6"	CURB & GUTTER
2	N00°55'07"W	4.28'	6"	CURB & GUTTER
3	N00°56'42"W	6.14'	6"	CURB & GUTTER
4	N01°03'17"W	16.39'	6"	CURB & GUTTER
5	N00°49'09"W	29.10'	6"	CURB & GUTTER
6	N01°14'28"W	9.44'	6"	CURB & GUTTER
7	N00°35'44"W	5.85'	6"	CURB & GUTTER
8	N01°54'58"W	4.28'	6"	CURB & GUTTER
9	N00°39'51"W	6.14'	6"	CURB & GUTTER
10	N00°53'39"W	12.62'	6"	CURB & GUTTER
11	N00°56'58"W	70.27'	6"	CURB & GUTTER
12	N00°52'59"W	14.52'	6"	CURB & GUTTER

**CAUTION:
 1.3" HP GAS!**
 CONTRACTOR TO VERIFY EXACT LOCATION AND MUST NOTIFY SDG&E IN ADVANCE PRIOR TO EXCAVATION. SDG&E STAND BY REQUIRED.

NOTE: SEE SHEET C-14 FOR CURB RAMP DETAILS

NOTE: STATIONING FOR TOP OF CURB IS PROPOSED FOR THIS SET DRAWINGS

RICK ENGINEERING COMPANY
 5620 FRIARS ROAD
 SAN DIEGO, CA 92110
 619-291-0707
 (FAX) 619-291-4165
 J-17721
 rickengineering.com
 San Diego Riverside - Orange - Sacramento - San Luis Obispo - Phoenix - Tucson - Denver

Karen Van Ert
 KAREN S. VAN ERT
 R.C.E. 56991
 EXP. 6-30-2021

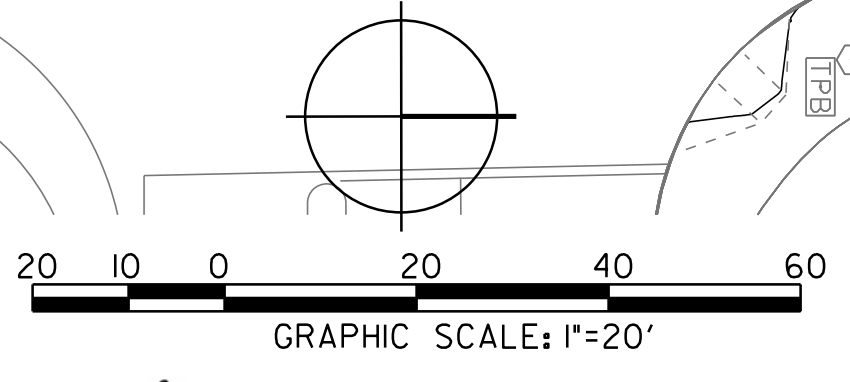

SYMBOLOLOGY:
 - - - - - SAWCUT

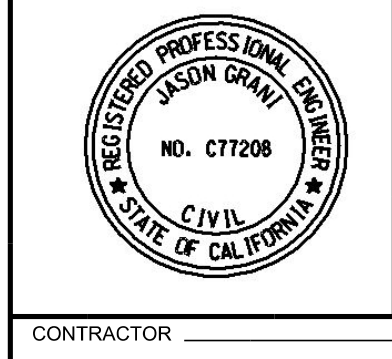
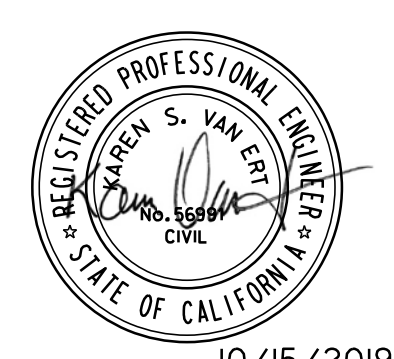

WANGENHEIM NEIGHBORHOOD JOINT USE FACILITY
IMPROVEMENT PLANS BLACK MOUNTAIN ROAD
 CITY OF SAN DIEGO, CALIFORNIA
 PUBLIC WORKS DEPARTMENT
 SHEET 35 OF 142 SHEETS
 WBS S-15007
 APPROVED: 10/13/2020
 FOR CITY ENGINEER: JASON GRANI
 DATE: 7/20/20
 PRINT NAME: RCE#
 SUBMITTED BY: YOVANNA LEWIS
 PROJECT MANAGER
 CHECKED BY: MEHDI RASHIDPOUR-HARISH
 PROJECT ENGINEER
 DESCRIPTION BY APPROVED DATE FILMED
 ORIGINAL REC 270-1731
 ADDENDUM B REC 1/11/2021 CCS27 COORDINATE
 1910-6291
 CCS83 COORDINATE
 CONTRACTOR: DATE STARTED: 10/15/2019
 INSPECTOR: DATE COMPLETED: 10/15/2019
40846-35-D

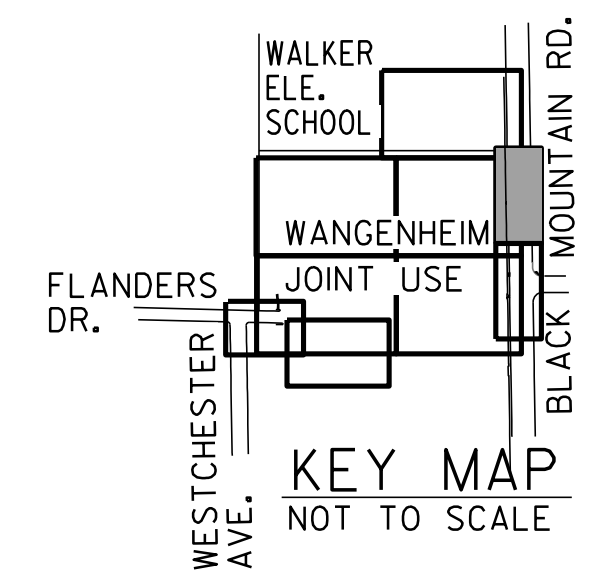

- IMPROVEMENT NOTES:**
- ① INSTALL SIDEWALK TO MATCH EXISTING WIDTH PER SDG-155
 - ② INSTALL NEW SIDEWALK PER SDG-155, WIDTH PER PLAN
 - ③ PROTECT EXISTING CURB & GUTTER IN PLACE
 - ④ ADJUST EXISTING TELEPHONE VAULT TO FINISH GRADE
 - ⑤ PROTECT EXISTING TRAFFIC SIGN TO FINISH GRADE. ENSURE 4' MINIMUM PATH CLEARANCE AND 7' MINIMUM SIGN HEIGHT CLEARANCE
 - ⑥ PROTECT EXISTING COX COMMUNICATION MANHOLE IN PLACE
 - ⑦ PROTECT EXISTING CATHODIC PROTECTION AND SDG&E MANHOLE IN PLACE
 - ⑧ PROTECT EXISTING PEDESTRIAN CROSSING SIGN IN PLACE
 - ⑨ PROTECT EXISTING STREET LIGHT IN PLACE
 - ⑩ ADJUST EXISTING TRAFFIC PULL BOX TO FINISH GRADE
 - ⑪ INSTALL "TYPE C-2" CURB RAMP PER SDG-135 (SEE DETAIL SHEET C-14)
 - ⑫ INSTALL "TYPE G" CURB AND GUTTER PER SDG-151
 - ⑬ PROTECT EXISTING TRAFFIC SIGNS IN PLACE
 - ⑭ FOR ACCESSIBILITY PATH DETAIL, SEE SHEET C-14
 - ⑮ PROTECT EXISTING SDG&E MANHOLE IN PLACE
 - ⑯ ADJUST EXISTING ELECTRICAL TRANSFORMER TO FINISH GRADE
 - ⑰ PROTECT EXISTING BUS STOP AT FINISH GRADE. CONTRACTOR TO ENSURE 4' MINIMUM PATH CLEARANCE AND 7' MINIMUM SIGN HEIGHT CLEARANCES. SEE NOTES ON SHEET G-04 CONTRACTOR TO PROVIDE NEW POST, AND MTS TO PROVIDE BUS STOP SIGN. CONTRACTOR TO COORDINATE WITH MTS.
 - ⑱ REPLACE EXISTING BUS STOP BENCHES AFTER NEW SIDEWALK IS INSTALLED
 - ⑲ MATCH EXISTING CURB & GUTTER PER SDG-151
 - ⑳ EXISTING VALVES TO REMAIN
 - ㉑ ADJUST EXISTING AIR RELEASE VALVE TO FINISH GRADE
 - ㉒ ADJUST EXISTING CORROSION TEST STATION TO FINISH GRADE
 - ㉓ PROTECT EXISTING ELECTRICAL TRANSFORMER IN PLACE
 - ㉔ FOR PATHWAY FINE GRADING, SEE SHEET C-12
 - ㉕ MATCH EXIST. SIDEWALK OR EXTEND TO NEAREST SIDEWALK JOINT FOR CLEAN CONSTRUCTION OF SIDEWALK
 - ㉖ PROTECT EXISTING SIDEWALK
 - ㉗ PROTECT EXISTING TRAFFIC PULL BOX IN PLACE



IMPORTANT NOTICE
 SECTION 4215/4217 OF THE GOVERNMENT CODE REQUIRES A DIG ALERT IDENTIFICATION NUMBER BE ISSUED BEFORE A "PERMIT TO EXCAVATE" WILL BE VALID. FOR YOUR DIG ALERT I.D. NUMBER, CALL UNDERGROUND SERVICE ALERT TOLL FREE 1-800-422-4133 AT LEAST TWO WORKING DAYS BEFORE YOU DIG.

C-22

WANGENHEIM NEIGHBORHOOD JOINT USE FACILITY
IMPROVEMENT PLANS
BLACK MOUNTAIN ROAD

CITY OF SAN DIEGO, CALIFORNIA PUBLIC WORKS DEPARTMENT SHEET 36 OF 142 SHEETS		WBS S-15007
APPROVED: FOR CITY ENGINEER JASON GRANI PRINT NAME	DATE 10/13/2020 77208	SUBMITTED BY: YOVANNA LEWIS PROJECT MANAGER
DESCRIPTION	BY	APPROVED
ORIGINAL	REC	DATE
ADDENDUM B	REC	DATE
DATE STARTED	DATE COMPLETED	
CONTRACTOR INSPECTOR		40846-36-D

EXISTING UTILITIES NOTE:
 ALL EXISTING UTILITIES SHOWN ON THESE PLANS ARE PLOTTED FROM RECORD DATA AT THEIR APPROXIMATE LOCATIONS. UNDERGROUND FACILITIES MAY EXIST WHICH HAVE NOT BEEN REPORTED OR ARE NOT OF RECORD. CONTRACTOR SHALL VERIFY THE LOCATION OF ALL PERTINENT UTILITIES IN THE FIELD PRIOR TO THE START OF CONSTRUCTION.



Karen S. Van Ert
 KAREN S. VAN ERT R.C.E 56991 EXP. 6-30-2021 DATE 10-15-2019

CURB DATA

NO.	DELTA OR BRG.	RADIUS	LENGTH	REMARKS
1	N0°52'59"W		19.06'	6" CURB & GUTTER

NOTE: STATIONING FOR TOP OF CURB IS PROPOSED FOR THIS SET DRAWINGS

SYMBOLOLOGY:
 - - - - - SAWCUT

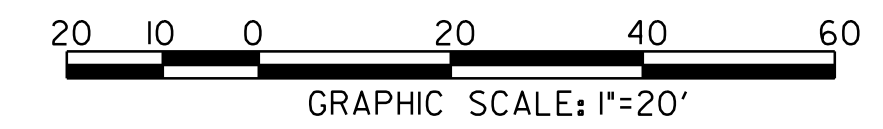

RICK ENGINEERING COMPANY
 5620 FRIARS ROAD
 SAN DIEGO, CA 92110
 619-291-0707
 (FAX) 619-291-4165
 rickengineering.com
 Riverside - Orange - Sacramento - San Luis Obispo - Phoenix - Tucson - Denver

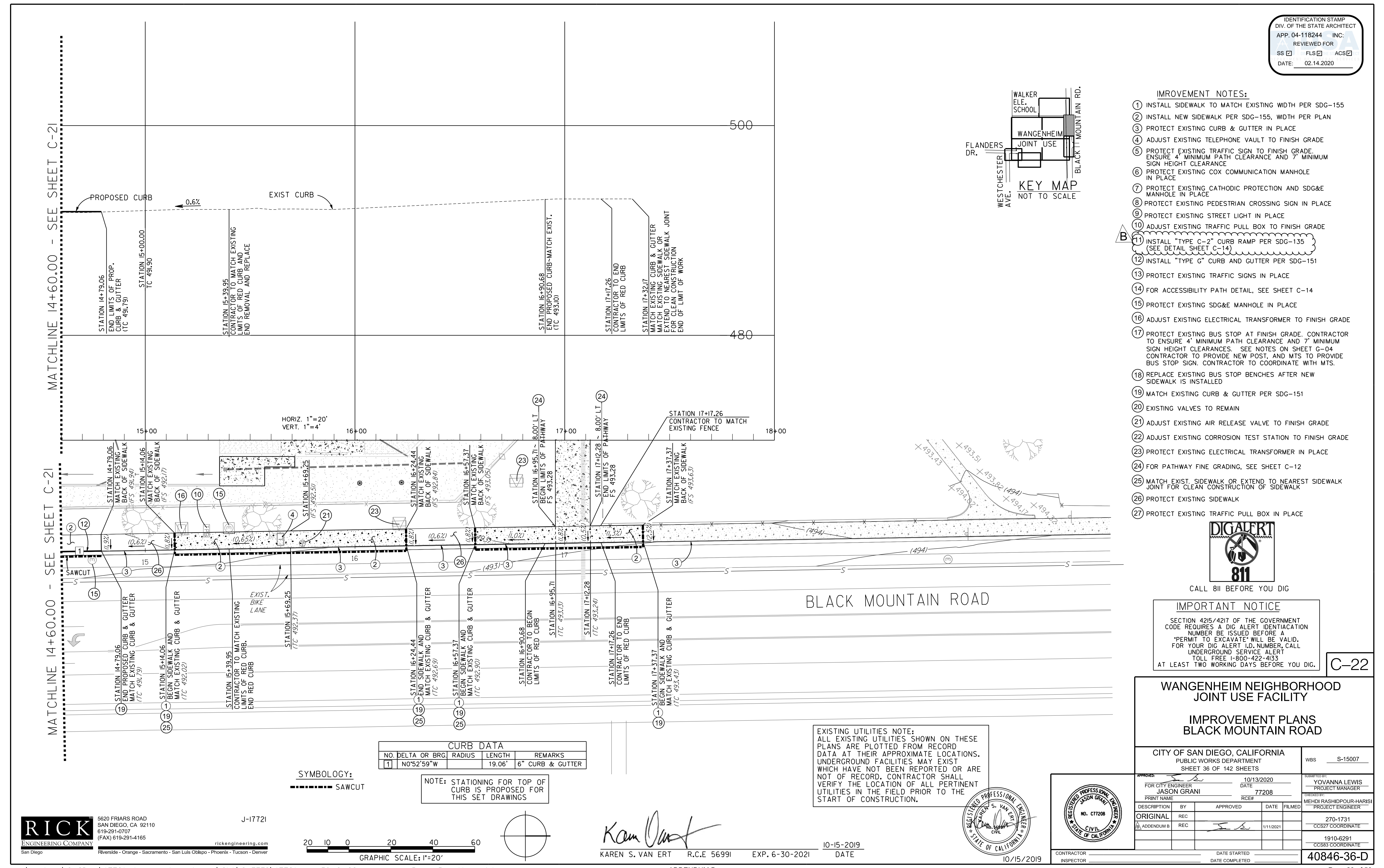

IDENTIFICATION STAMP
 DIV. OF THE STATE ARCHITECT
 APP. 04-118244 INC.
 REVIEWED FOR
 SS FLS ACS
 DATE: 02.14.2020

POST-CONSTRUCTION BMP CERTIFICATION:

AS THE PROFESSIONAL IN RESPONSIBLE CHARGE FOR THE DESIGN OF THIS PROJECT, I CERTIFY THAT I HAVE INSPECTED ALL CONSTRUCTED LOW IMPACT DEVELOPMENT (LID) SITE DESIGN, SOURCE CONTROL, HYDROMODIFICATION MANAGEMENT, AND TREATMENT CONTROL BMPs REQUIRED PER THE STORM WATER STANDARDS MANUAL AND CONTRACT REQUIREMENTS; AND THAT SAID BMPs HAVE BEEN CONSTRUCTED IN COMPLIANCE WITH THE APPROVED PLANS AND ALL APPLICABLE SPECIFICATIONS, PERMITS, ORDINANCES AND SAN DIEGO REGIONAL MS4 PERMIT.

I UNDERSTAND THAT THIS BMP CERTIFICATION STATEMENT DOES NOT CONSTITUTE AN OPERATION AND MAINTENANCE VERIFICATION.

SIGNATURE: _____
 DATE OF SIGNATURE: _____
 PRINTED NAME: _____
 TITLE: _____
 PHONE NO.: _____

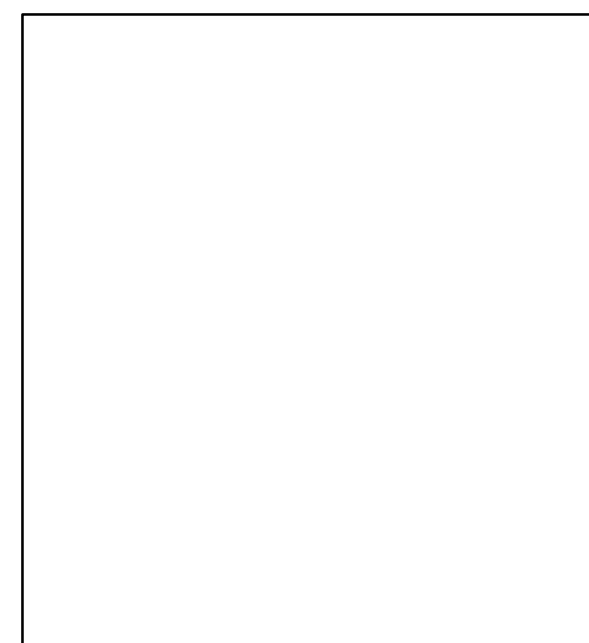

SITE DESIGN, SOURCE CONTROL AND POLLUTANT CONTROL BMP OPERATION & MAINTENANCE PROCEDURE DETAILS						
STORM WATER MANAGEMENT AND DISCHARGE CONTROL MAINTENANCE AGREEMENT APPROVAL NO.:						
O&M RESPONSIBLE PARTY DESIGNEE: DEPARTMENT OF PARKS AND RECREATION, CITY OF SAN DIEGO						
BMP DESCRIPTION	INSPECTION FREQUENCY	MAINTENANCE FREQUENCY	MAINTENANCE METHOD	QUANTITY	INCLUDED IN O&M MANUAL	SHEET NUMBER(S)
SITE DESIGN LANDSCAPED AREAS	MONTHLY (NOTE: INSPECTOR SHALL CHECK FOR THE FOLLOWING MAINTENANCE INDICATORS: EROSION IN THE FORM OF RILLS OR GULLIES, PONDING WATER, BARE AREAS, BURROWS, MOUNDS, AND TRASH.)	1. AS DETERMINED BY INSPECTION; AND 2. ON OR BEFORE SEPTEMBER 30TH.	1. FILL AND COMPACT AREAS OF RUTS, RILLS, OR GULLIES; 2. RE-SEED AND/OR PLANT SLOPES AND AREAS OF EXPOSED SOILS; AND 3. ROUTINE MOWING AND TRIMMING AND TRASH REMOVAL.	N/A	YES	L1-L21
OUTLET PROTECTION	1. MONTHLY; 2. WITHIN 24 HOURS AFTER EACH "SIGNIFICANT RAIN EVENT" AND 3. WITHIN 24 HOURS FOLLOWING CONSTRUCTION IN IMMEDIATE AREA OF OUTLET PROTECTION	1. AS DETERMINED BY INSPECTION; 2. WHEN DISTURBED OR MISSING ROCKS (RIP RAP), OR SOIL EROSION BELOW AND/OR ADJACENT TO OUTLET PROTECTION ARE OBSERVED.	1. REMOVE TRASH, DEBRIS AND LEAVES. REPAIR ANY DAMAGE TO ROOF DRAINS; 2. IMMEDIATELY REPOSITION ALL DISPLACED ENERGY DISSIPATER; AND 3. IF SOIL EROSION IS FOUND, EXTEND ENERGY DISSIPATER (I.E. LANDSCAPE ROCKS AND/OR SPLASH PADS); REPOSITION OR INCREASE LIMITS OF ENERGY DISSIPATER TO COVER ERODED AREA.	1	YES	C-13 & C-22 - C-25
SOURCE CONTROL INTEGRATED PEST MANAGEMENT	MONTHLY (NOTE: INSPECTOR SHALL CHECK FOR INDICATIONS OF THE PRESENCE OF PESTS ON-SITE)	WHEN THE PEST OR PESTS, OBSERVED IN GREATEST ABUNDANCE OR CAUSE THE MOST OBSERVED SYMPTOMS, ARE IDENTIFIED.	CHECK FREQUENTLY FOR PESTS, AND TREAT WITH A PESTICIDE ONLY WHEN A PEST IS PRESENT, ETC.	N/A	YES	L1-L21
EFFECTIVE IRRIGATION SYSTEM	MONTHLY	WHEN BROKEN SPRINKLER HEADS, RAIN SHUTOFF DEVICES, AND FLOW REDUCERS ARE OBSERVED, OR RUNNING SPRINKLERS IN RAIN ARE OBSERVED.	REPAIR OR REPLACE THE BROKEN AND/OR MALFUNCTIONING PARTS OF IRRIGATION SYSTEM.	N/A	YES	L1-L21
SOURCE CONTROL TRASH STORAGE AREAS	WEEKLY	1. AS DETERMINED BY INSPECTION; 2. STANDING WATER IN TRASH STORAGE AREA. 3. LOOSE TRASH OR DEBRIS. 4. LEAKED OR SPILLED MATERIALS. 5. COMPROMISED FENCE, SCREEN, GATE, WALL, BIN, LID OR ROOF AWNING (WHERE APPLICABLE). 6. CRACKED OR OTHERWISE COMPROMISED PAVING OR OTHER FLAWED FLOOR SURFACE (AS APPLICABLE).	1. IF STANDING WATER IS OBSERVED IN THE AREA, DETERMINE THE WATER SOURCE AND REMOVE THE SOURCE. ALLOW STANDING WATER TO EVAPORATE. IF WATER DOES NOT EVAPORATE IN 48 HOURS, REDISTRIBUTE THE WATER TO LANDSCAPED AREA(S). DO NOT DRAIN WATER TO STORM DRAIN SYSTEM; 2. REMOVE AND PROPERLY DISPOSE LOOSE TRASH, DEBRIS, AND LEAKED OR SPILLED MATERIALS. USE APPROPRIATE SPILL CLEANUP MATERIAL AS NECESSARY TO REMOVE ALL LEAKED AND SPILLED MATERIALS INCLUDING MATERIALS ADHERED TO PAVEMENT.	4	YES	C-13 & C-22 - C-25
PREVENTIVE STENCILING AND SIGNAGE	ANNUALLY	WHEN FULLY OR PARTIALLY ERASED SIGNS ARE OBSERVED; WHEN DUMPING OF TRASH ARE OBSERVED AT PUBLIC ACCESS POINTS, BUILDING ENTRANCES, PUBLIC PARKS, ETC.	1. REPLACE OR REPAINT THE STENCILS AND SIGNAGE SO THAT THEY ARE LEGIBLE; AND 2. MAKE SURE THAT THEY ARE PLACED AT ALL REQUIRED LOCATIONS (I.E. - ALL INLETS).	35	YES	C-13 & C-22 - C-25
POLLUTANT CONTROL BIOFILTRATION FACILITY (HMP INCLUDED)	1. TWICE A YEAR (ON OR BEFORE SEPTEMBER 15TH AND FOLLOWING THE RAINY SEASON AFTER MAY 1ST); AND 2. AFTER EACH "SIGNIFICANT RAIN EVENT" (NOTE: INSPECTOR SHALL CHECK FOR THE FOLLOWING MAINTENANCE INDICATORS: EROSION IN THE FORM OF RILLS OR GULLIES, PONDING WATER, BARE AREAS, DEAD VEGETATION, ANIMAL BURROWS, HOLES, MOUNDS, AND TRASH)	1. AS DETERMINED BY INSPECTION; AND 2. ON OR BEFORE SEPTEMBER 30TH AND FOLLOWING THE RAINY SEASON AFTER MAY 1ST; AND 3. AFTER EACH "SIGNIFICANT RAIN EVENT" ²	1. REPLACE MULCH IN AREAS OF RUTS, RILLS, OR GULLIES; 2. RE-SEED AND/OR PLANT SLOPES AND AREAS OF EXPOSED SOILS; 3. ROUTINE MAINTENANCE TO REMOVE ACCUMULATED MATERIALS SUCH AS TRASH AND DEBRIS; 4. NON-ROUTINE MAINTENANCE WILL BE REQUIRED TO BACKWASH AND CLEAR UNDERDRAINS IF INSPECTION INDICATES UNDERDRAINS ARE CLOGGED; AND 5. DEPENDING ON POLLUTANT LOADS, SOILS MAY NEED TO BE REPLACED EVERY 5 TO 10 YEARS. 6. THE RISER STRUCTURE SHOULD BE MAINTAINED TO AVOID CLOGGING AND ANY LEAKAGE THROUGH BOLTHOLES.	1	YES	C-10, C-13 & C-22 - C-25
HMP EXEMPT No						
NOTES: 1. REFER TO THE "PRIORITY DEVELOPMENT PROJECT (PDP) STORM WATER QUALITY MANAGEMENT PLAN (SWQMP) FOR WANGENHEIM NEIGHBORHOOD JOINT USE FACILITY", DATED AUGUST 16, 2019 OR ANY REVISIONS THEREOF FOR MORE SPECIFIC INFORMATION. 2. A SIGNIFICANT RAIN EVENT CONSIDERED WHENEVER THE NATIONAL WEATHER SERVICE REPORTS 0.50" OF RAIN IN 48 HOURS FOR THE LOCAL COMMUNITY. 3. DURING THE FIRST YEAR OF NORMAL OPERATION, ALL BMPs SHOULD BE INSPECTED ONCE BEFORE AUGUST 31 AND THEN MONTHLY FROM SEPTEMBER THROUGH MAY. THE MINIMUM INSPECTION AND MAINTENANCE FREQUENCY SHOULD BE DETERMINED BASED ON THE RESULTS OF THE FIRST YEAR INSPECTIONS.						

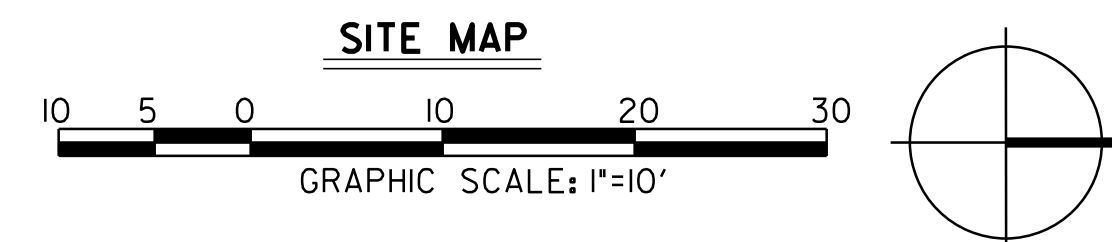
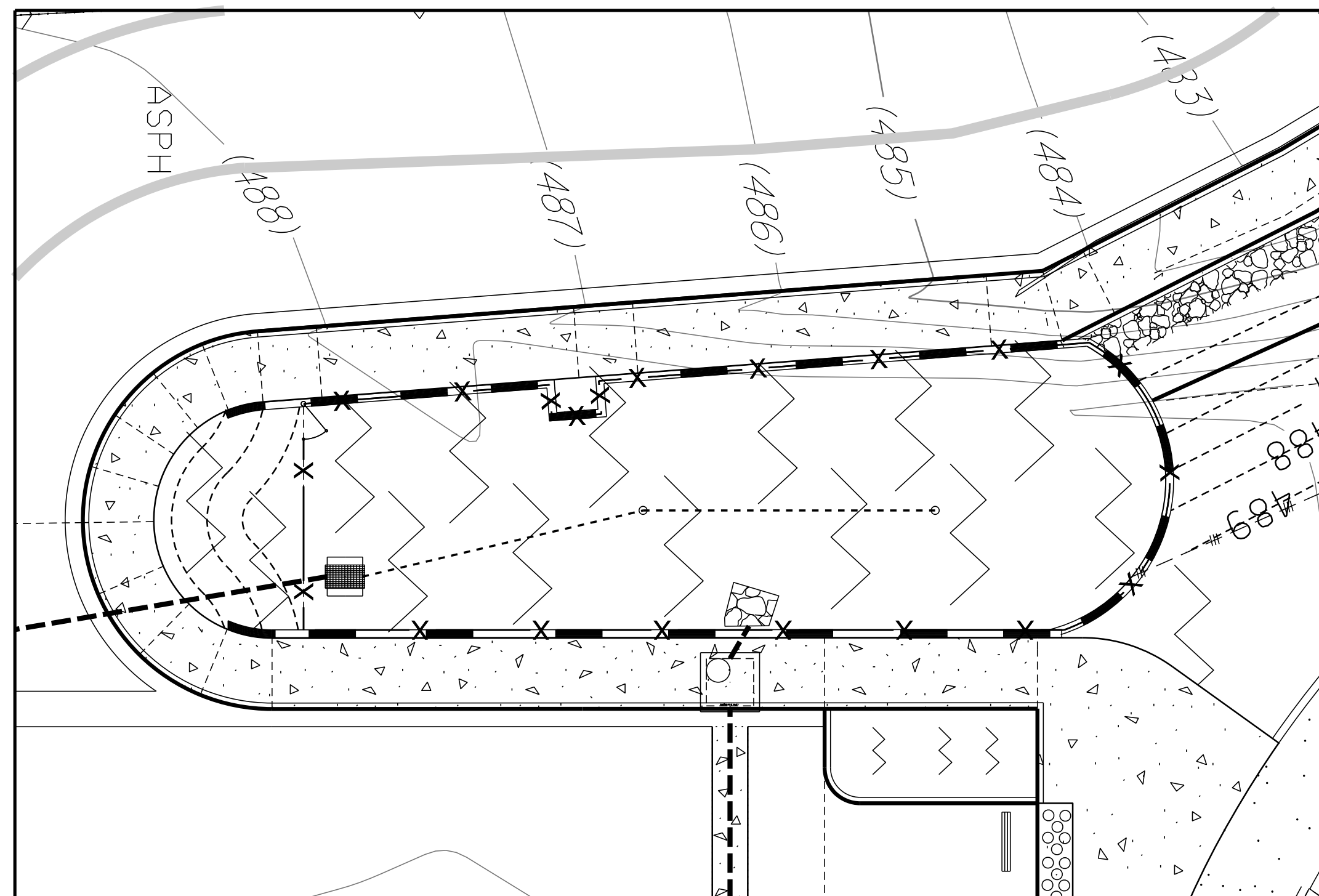

RICK ENGINEERING COMPANY
 5620 FRIARS ROAD
 SAN DIEGO, CA 92110
 619-291-0707
 (FAX) 619-291-4165
 J-17721
 rickengineering.com
 San Diego Riverside - Orange - Sacramento - San Luis Obispo - Phoenix - Tucson - Denver

STORM WATER REQUIREMENTS:

THIS PROJECT IS SUBJECT TO MUNICIPAL CODE SECTION 4303 AND ORDER NO. R9-2013-0001 AS AMENDED BY R9-2015-0001 AND R9-2015-0100.

ALL WORK RELATED TO POST-CONSTRUCTION STORMWATER QUALITY SHALL BE IN ACCORDANCE WITH THE STORM WATER QUALITY MANAGEMENT PLAN ENTITLED, PROJECT NAME/ WBS OR IO: WANGENHEIM NEIGHBORHOOD JOINT USE FACILITY PROJECT ADDRESS: 9230 GOLD COAST DR, SAN DIEGO, CA. 92126 PREPARED BY: RICK ENGINEERING COMPANY DATE PREPARED: AUGUST 16, 2019

POST-CONSTRUCTION BMPs ARE REQUIRED, SEE SHEET(S) C-10 & C-26

THE CONTRACTOR SHALL NOTIFY THE RESIDENT ENGINEER (RE) 10 WORKING DAYS PRIOR TO THE INSTALLATION OF ALL HMP FACILITIES AND PERMANENT TREATMENT CONTROL BMPs. THE RE SHALL COORDINATE THE INSPECTION OF PERMANENT BMPs WITH THE CITY PROJECT MANAGER (PM) PRIOR TO THE INSTALLATION. THEN THE PM SHALL COORDINATE WITH THE ENGINEER OF WORK (EOW) TO INSPECT AND APPROVE PERMANENT BMPs TO ENSURE THAT THEY ARE INSTALLED PER THE APPROVED SWQMP AND PLANS. AFTER APPROVAL, THE EOW SHALL SUBMIT A SIGNED DS-563 FORM TO THE RE. THE RE SHALL THEN SUBMIT THE ORIGINAL COPY OF THE FORM TO THE CONSTRUCTION STORM WATER SECTION.

Karen S. Van Ert
 KAREN S. VAN ERT R.C.E 56991 EXP. 6-30-2021

10-15-2019
 DATE

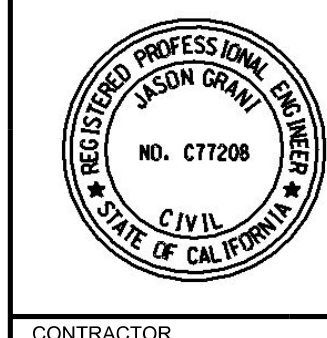

WANGENHEIM NEIGHBORHOOD JOINT USE FACILITY
BMP MAP FOR PRIORITY DEVELOPMENT PROJECT

CITY OF SAN DIEGO, CALIFORNIA PUBLIC WORKS DEPARTMENT SHEET 37 OF 142 SHEETS		WBS S-15007
APPROVED FOR CITY ENGINEER JASON GRANI PRINT NAME	DATE 10/13/2020 77208	SUBMITTED BY: YOVANNA LEWIS PROJECT MANAGER
DESCRIPTION	BY	APPROVED
ORIGINAL	REC	
ADDENDUM B	REC	1/11/2021
CREATED BY: MEHDI RASHIDPOUR-HARISI PROJECT ENGINEER		NO. 270-1731 CCS27 COORDINATE 1910-6291 CCS83 COORDINATE
CONTRACTOR INSPECTOR		DATE STARTED DATE COMPLETED
		40846-37-D

C-23

NOTE REVISD

ADDENDUM B

City of San Diego Development Services Storm Water Requirements Applicability Checklist FORM DS-560 November 2018

Project Address: WANGENHEIM MIDDLE SCHOOL, 9230 GOLD COAST DR., SAN DIEGO, CA, 92126 Project Number:

SECTION 1. Construction Storm Water BMP Requirements:
 All construction sites are required to implement construction BMPs in accordance with the performance standards in the Storm Water Standards Manual. Some sites are additionally required to obtain coverage under the State Construction General Permit (CGP), which is administered by the State Regional Water Quality Control Board.

For all projects complete PART A: If project is required to submit a SWPPP or WPCP, continue to PART B.

PART A: Determine Construction Phase Storm Water Requirements.

1. Is the project subject to California's statewide General NPDES permit for Storm Water Discharges Associated with Construction Activities, also known as the State Construction General Permit (CGP)? (Typically projects with land disturbance greater than or equal to 1 acre.)
 Yes; SWPPP required, skip questions 2-4 No; next question

2. Does the project propose construction or demolition activity, including but not limited to, clearing, grading, grubbing, excavation, or any other activity resulting in ground disturbance and/or contact with storm water?
 Yes; WPCP required, skip questions 3-4 No; next question

3. Does the project propose routine maintenance to maintain original line and grade, hydraulic capacity, or original purpose of the facility? (Projects such as pipeline/utility replacement)
 Yes; WPCP required, skip question 4 No; next question

4. Does the project only include the following Permit types listed below?
 • Electrical Permit, Fire Alarm Permit, Fire Sprinkler Permit, Plumbing Permit, Sign Permit, Mechanical Permit, Spa Permit.
 • Individual Right of Way Permits that exclusively include only ONE of the following activities: water service, sewer lateral, or utility service.
 • Right of Way Permits with a project footprint less than 150 linear feet that exclusively include only ONE of the following activities: curbs ramp, sidewalk and driveway apron replacement, pot holing, curb and gutter replacement, and retaining wall encroachments.
 Yes; no document required

Check one of the boxes below, and continue to PART B:

If you checked "Yes" for question 1, a SWPPP is REQUIRED. Continue to PART B

If you checked "No" for question 1, and checked "Yes" for question 2 or 3, a WPCP is REQUIRED. If the project proposes less than 5,000 square feet of ground disturbance AND has less than a 5-foot elevation change over the entire project area, a Minor WPCP may be required instead. Continue to PART B.

If you checked "No" for all questions 1-3, and checked "Yes" for question 4, PART B does not apply and no document is required. Continue to Section 2.

1. More information on the City's construction BMP requirements as well as CGP requirements can be found at: www.sandiego.gov/stormwater/regulations/index.shtml

Printed on recycled paper. Visit our web site at www.sandiego.gov/development-services.
 Upon request, this information is available in alternative formats for persons with disabilities.
 DS-560 (11-18)

Page 2 of 4 City of San Diego • Development Services • Storm Water Requirements Applicability Checklist

PART B: Determine Construction Site Priority
 This prioritization must be completed within this form, noted on the plans, and included in the SWPPP or WPCP. The city reserves the right to adjust the priority of projects both before and after construction. Construction projects are assigned an inspection frequency based on if the project has a "high threat to water quality." The City has aligned the local definition of "high threat to water quality" to the risk determination approach of the State Construction General Permit (CGP). The CGP determines risk level based on project specific sediment risk and receiving water risk. Additional inspection is required for projects within the Areas of Special Biological Significance (ASBS) watershed. NOTE: The construction priority does NOT change construction BMP requirements that apply to projects; rather, it determines the frequency of inspections that will be conducted by city staff.

Complete PART B and continued to Section 2

1. ASBS
 a. Projects located in the ASBS watershed.

2. High Priority
 a. Projects that qualify as Risk Level 2 or Risk Level 3 per the Construction General Permit (CGP) and not located in the ASBS watershed.
 b. Projects that qualify as LUP Type 2 or LUP Type 3 per the CGP and not located in the ASBS watershed.

3. Medium Priority
 a. Projects that are not located in an ASBS watershed or designated as a High priority site.
 b. Projects that qualify as Risk Level 1 or LUP Type 1 per the CGP and not located in an ASBS watershed.
 c. WPCP projects (>5,000sf of ground disturbance) located within the Los Penasquitos watershed management area.

4. Low Priority
 a. Projects not subject to a Medium or High site priority designation and are not located in an ASBS watershed.

SECTION 2. Permanent Storm Water BMP Requirements.
 Additional information for determining the requirements is found in the Storm Water Standards Manual.

PART C: Determine if Not Subject to Permanent Storm Water Requirements.
 Projects that are considered maintenance, or otherwise not categorized as "new development projects" or "redevelopment projects" according to the Storm Water Standards Manual are not subject to Permanent Storm Water BMPs.

If "yes" is checked for any number in Part C, proceed to Part F and check "Not Subject to Permanent Storm Water BMP Requirements".
 If "no" is checked for all of the numbers in Part C continue to Part D.

1. Does the project only include interior remodels and/or is the project entirely within an existing enclosed structure and does not have the potential to contact storm water? Yes No

2. Does the project only include the construction of overhead or underground utilities without creating new impervious surfaces? Yes No

3. Does the project fall under routine maintenance? Examples include, but are not limited to: roof or exterior structure surface replacement, resurfacing or reconfiguring surface parking lots or existing roadways without expanding the impervious footprint, and routine replacement of damaged pavement (grinding, overlay, and pothole repair). Yes No

Page 3 of 4 City of San Diego • Development Services • Storm Water Requirements Applicability Checklist

PART D: PDP Exempt Requirements.
 PDP Exempt projects are required to implement site design and source control BMPs.
 If "yes" was checked for any questions in Part D, continue to Part F and check the box labeled "PDP Exempt."
 If "no" was checked for all questions in Part D, continue to Part E.

1. Does the project ONLY include new or retrofit sidewalks, bicycle lanes, or trails that:
 • Are designed and constructed to direct storm water runoff to adjacent vegetated areas, or other non-erodible permeable areas? Or,
 • Are designed and constructed to be hydraulically disconnected from paved streets and roads? Or,
 • Are designed and constructed with permeable pavements or surfaces in accordance with the Green Streets guidance in the City's Storm Water Standards manual?
 Yes; PDP exempt requirements apply No; next question

2. Does the project ONLY include retrofitting or redeveloping existing paved alleys, streets or roads designed and constructed in accordance with the Green Streets guidance in the City's Storm Water Standards Manual?
 Yes; PDP exempt requirements apply No; project not exempt.

PART E: Determine if Project is a Priority Development Project (PDP).
 Projects that match one of the definitions below are subject to additional requirements including preparation of a Storm Water Quality Management Plan (SWQMP).

If "yes" is checked for any number in PART E, continue to PART F and check the box labeled "Priority Development Project".
 If "no" is checked for every number in PART E, continue to PART F and check the box labeled "Standard Development Project".

1. New Development that creates 10,000 square feet or more of impervious surfaces collectively over the project site. This includes commercial, industrial, residential, mixed-use, and public development projects on public or private land. Yes No

2. Redevelopment project that creates and/or replaces 5,000 square feet or more of impervious surfaces on an existing site of 10,000 square feet or more of impervious surfaces. This includes commercial, industrial, residential, mixed-use, and public development projects on public or private land. Yes No

3. New development or redevelopment of a restaurant. Facilities that sell prepared foods and drinks for consumption, including stationary lunch counters and refreshment stands selling prepared foods and drinks for immediate consumption (SIC 5812), and where the land development creates and/or replaces 5,000 square feet or more of impervious surface. Yes No

4. New development or redevelopment on a hillside. The project creates and/or replaces 5,000 square feet or more of impervious surface (collectively over the project site) and where the development will grade on any natural slope that is twenty-five percent or greater. Yes No

5. New development or redevelopment of a parking lot that creates and/or replaces 5,000 square feet or more of impervious surface (collectively over the project site). Yes No

6. New development or redevelopment of streets, roads, highways, freeways, and driveways. The project creates and/or replaces 5,000 square feet or more of impervious surface (collectively over the project site). Yes No

Page 4 of 4 City of San Diego • Development Services • Storm Water Requirements Applicability Checklist

7. New development or redevelopment discharging directly to an Environmentally Sensitive Area. The project creates and/or replaces 2,500 square feet of impervious surface (collectively over project site), and discharges directly to an Environmentally Sensitive Area (ESA). "Discharging directly to" includes flow that is conveyed overland a distance of 200 feet or less from the project to the ESA, or conveyed in a pipe or open channel any distance as an isolated flow from the project to the ESA (i.e. not commingled with flows from adjacent lands). Yes No

8. New development or redevelopment projects of a retail gasoline outlet (RGO) that create and/or replaces 5,000 square feet of impervious surface. The development project meets the following criteria: (a) 5,000 square feet or more or (b) has a projected Average Daily Traffic (ADT) of 100 or more vehicles per day. Yes No

9. New development or redevelopment projects of an automotive repair shops that create and/or replaces 5,000 square feet or more of impervious surfaces. Development projects categorized in any one of Standard Industrial Classification (SIC) codes 5013, 5014, 5041, 7532, 7534, or 7536-7539. Yes No

10. Other Pollutant Generating Project. The project is not covered in the categories above, results in the disturbance of one or more acres of land and is expected to generate pollutants post construction, such as fertilizers and pesticides. This does not include projects creating less than 5,000 sf of impervious surface and where added landscaping does not require regular use of pesticides and fertilizers, such as slope stabilization using native plants. Calculation of the square footage of impervious surface need not include linear pathways that are for infrequent vehicle use, such as emergency maintenance access or bicycle pedestrian use, if they are built with pervious surfaces of if they sheet flow to surrounding pervious surfaces. Yes No

PART F: Select the appropriate category based on the outcomes of PART C through PART E.

1. The project is NOT SUBJECT TO PERMANENT STORM WATER REQUIREMENTS.

2. The project is a STANDARD DEVELOPMENT PROJECT. Site design and source control BMP requirements apply. See the Storm Water Standards Manual for guidance.

3. The project is PDP EXEMPT. Site design and source control BMP requirements apply. See the Storm Water Standards Manual for guidance.

4. The project is a PRIORITY DEVELOPMENT PROJECT. Site design, source control, and structural pollutant control BMP requirements apply. See the Storm Water Standards Manual for guidance on determining if project requires a hydromodification plan management.

Yovanna L. Lewis Associate Engineer
 Name of Owner or Agent (Please Print) Title
 Signature Date 11/12/2019

RICK ENGINEERING COMPANY
 5620 FRIARS ROAD
 SAN DIEGO, CA 92110
 619-291-0707
 (FAX) 619-291-4165
 rickengineering.com
 San Diego Riverside - Orange - Sacramento - San Luis Obispo - Phoenix - Tucson - Denver

J-17721

Karen S. Van Ert
 KAREN S. VAN ERT R.C.E 56991 EXP. 6-30-2021 DATE 10-15-2019

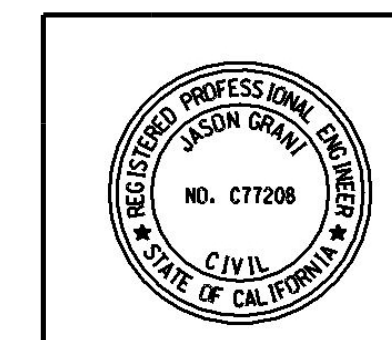
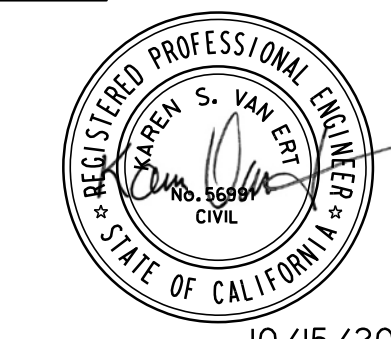

WANGENHEIM NEIGHBORHOOD JOINT USE FACILITY

BMP NOTES AND DETAILS

CITY OF SAN DIEGO, CALIFORNIA
 PUBLIC WORKS DEPARTMENT
 SHEET 39 OF 142 SHEETS

WBS S-15007

APPROVED: *Jason Gran* 10/13/2020 DATE 77208
 FOR CITY ENGINEER JASON GRANI
 PRINT NAME RCE#

SUBMITTED BY: YOVANNA LEWIS PROJECT MANAGER
 CHECKED BY: MEHDI RASHIDPOUR-HARISH PROJECT ENGINEER

DESCRIPTION	BY	APPROVED	DATE	FILMED
ORIGINAL	REC			
ADDENDUM B	REC	<i>SS</i>	1/11/2021	

1910-6291
 CCS83 COORDINATE

CONTRACTOR INSPECTOR DATE STARTED DATE COMPLETED

40846-39-D

C-25

B SIGNATURE ADDED

ADDENDUM B

NOTE
FOR REFERENCE ONLY.
NOT FOR CONSTRUCTION PURPOSES.
THIS SHEET HAS BEEN PROVIDED TO
SUPPLEMENT THE PDP SDGMP REPORT.

IDENTIFICATION STAMP
DIV. OF THE STATE ARCHITECT
APP. 04-118244 INC.
REVIEWED FOR
SS FLS ACS
DATE: 02.14.2020

NOTES

1. UNDERLYING HYDROLOGIC SOIL GROUP = NRCS TYPE D
2. THERE ARE NO EXISTING NATURAL HYDROLOGIC FEATURES LOCATED WITHIN THE PROJECT SITE
3. THE PROJECT SITE IS NOT LOCATED WITHIN A CRITICAL COARSE SEDIMENT YIELD AREAS (ATTACHMENT 2B)
4. BASED ON REVIEW OF AVAILABLE DATA, THE DEPTH OF REGIONAL GROUNDWATER TABLE BENEATH THE PROJECT SITE IS ESTIMATED TO BE EXCESS OF 100 FEET BGS. HOWEVER, LOCALIZED PERCHED WATER CONDITIONS MAY BE ENCOUNTERED, ESPECIALLY ALONG THE CONTACT BETWEEN FILL MATERIALS AND FORMATION MATERIALS.
5. A BIOFILTRATION BMP HAS BEEN PROPOSED IN DMA 2 (0.87 AC). THE BIOFILTRATION FACILITY (BMP 1) SERVES HYDROMODIFICATION FLOW CONTROL AND POLLUTANT CONTROL PURPOSES. THE FOOTPRINT OF BMP 1B IS 1529 SF. PLEASE REFER ATTACHMENT 4 FOR TYPICAL PLAN AND SECTION VIEW OF THE BMP AND ATTACHMENT 1E FOR BMP CROSS SECTION SCHEMATIC AND HMP ORIFICE DETAILS. SEE SHEET C-26.
6. BMP 1 TREATS WATER QUALITY VOLUME FROM DMA-2A AND CONVEYS TO POC-2. DMA-2B IS HYDRAULICALLY DISCONNECTED TO DMA-2A AND CONVEYS TO POC-2. DMA-1 CONVEYS TO POC-1. FOR HMP MODEL NETWORK PLEASE REFER THE SWMM MODEL SCHEMATIC IN ATTACHMENT 2D.
7. DMA-1 AND DMA-2B ARE SELF-MITIGATING DMAS PURSUANT TO SECTION 5.2.1 OF THE 2018 STORM WATER STANDARDS (SWS) MANUAL. PLEASE REFER TO ATTACHMENT 1E FOR SELF-MITIGATING DMA STANDARDS CHECKLIST. SELF-MITIGATING DMAS ARE NOT SUBJECT TO HMP PER SECTION 5.2.1.
8. THE PROJECT IS REQUIRED TO REPLACE THE EXISTING SIDEWALKS ADJACENT TO THE PROJECT SITE ALONG BLACK MOUNTAIN ROAD AND FLANDERS DRIVE AS PART OF THE CITY'S LARGER MASTER PLANNING EFFORT TO BRING THE CITY IN COMPLIANCE WITH ADA REQUIREMENTS. AS SUCH, THE SIDEWALKS ALONG BLACK MOUNTAIN ROAD AND FLANDERS DRIVE IN THE CITY RIGHT-OF-WAY WILL BE REPLACED TO BE ADA COMPLIANT WHICH INCLUDE MINOR CHANGES TO GRADES BUT, DO NOT INCLUDE ANY CHANGES TO THE OVERALL DRAINAGE OR ALIGNMENT. PER TABLE 1-2 OF THE 2018 SWS MANUAL, THIS QUALIFIES AS A ROUTINE MAINTENANCE ACTIVITY AND WOULD NOT BE SUBJECT TO PERMANENT, POST- CONSTRUCTION STORM WATER REQUIREMENTS.
9. THE PROPOSED SIDEWALK/CURB RAMP IN DMA 3 WEST OF THE PROPOSED BIOFILTRATION BASIN (BMP-1) CONNECTING TO FLANDERS DRIVE IS BEING ADDED AS PART OF THE CITY'S LARGER MASTER PLANNING EFFORT TO BRING THE CITY IN COMPLIANCE WITH ADA REQUIREMENTS. IT HAS BEEN DESIGNED TO DRAIN TO THE PROPOSED ADJACENT GREEN GUTTER (COBBLE/ROCK LINED SWALE) PER APPENDIX J.2 OF THE 2018 SWS MANUAL AND QUALIFIES FOR PDP EXEMPTION.
10. IT IS IMPORTANT TO NOTE THAT THE POCs IDENTIFIED IN THIS EXHIBIT ARE APPROXIMATE LOCATIONS BASED ON THE SITE TOPOGRAPHY AND ENGINEERING JUDGEMENT. CONNECTIONS OF THE ONSITE STORM DRAINS TO THE OFFSITE DRAINAGE COULD NOT BE VERIFIED EVEN AFTER EXTENSIVE AS-BUILT RESEARCH (BY RICK, CITY OF SAN DIEGO AND SAN DIEGO UNIFIED SCHOOL DISTRICT) AND FIELD SURVEY.



CALL 811 BEFORE YOU DIG

C-27

**WANGENHEIM NEIGHBORHOOD
JOINT USE FACILITY
BMP MAP FOR PRIORITY
DEVELOPMENT PROJECTS
DMA MAP**

CITY OF SAN DIEGO, CALIFORNIA
PUBLIC WORKS DEPARTMENT
SHEET 41 OF 142 SHEETS

APPROVED: <i>[Signature]</i> FOR CITY ENGINEER JASON GRANI PRINT NAME	DATE 10/13/2020 77208 RCE#	SUBMITTED BY: YOVANNA LEWIS PROJECT MANAGER	WBS S-15007
DESCRIPTION ORIGINAL	BY REC	APPROVED <i>[Signature]</i>	DATE 1/11/2021
ADDENDUM B	REC		270-1731 CCS27 COORDINATE
			1910-6291 CCS83 COORDINATE
CONTRACTOR INSPECTOR			DATE STARTED DATE COMPLETED
			40846-41-D



[Signature]
KAREN S. VAN ERT R.C.E 56991 EXP. 6-30-2021 DATE 10-15-2019

NOTE #5&9 REVISED AND ACREAGE ADDED

ADDENDUM B

RICK ENGINEERING COMPANY
5620 FRIARS ROAD
SAN DIEGO, CA 92110
619-291-0707
(FAX) 619-291-4165
rickengineering.com
San Diego Riverside - Orange - Sacramento - San Luis Obispo - Phoenix - Tucson - Denver

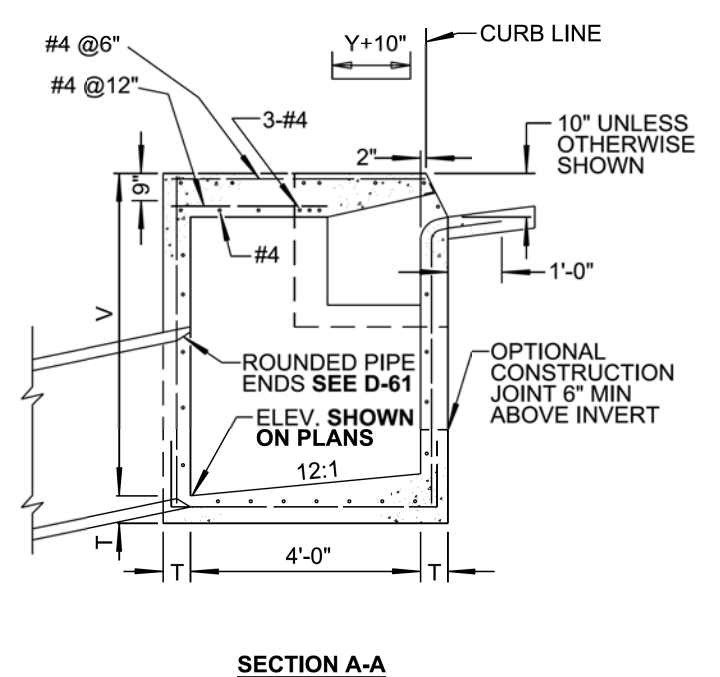
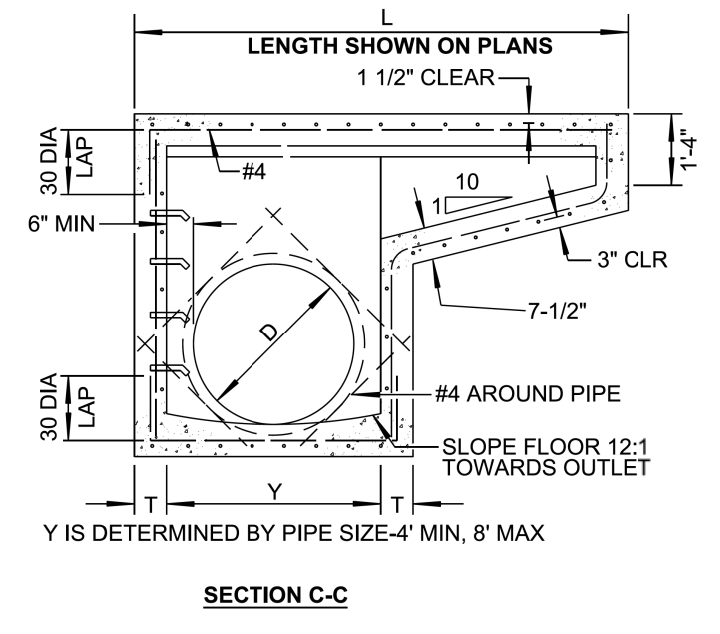
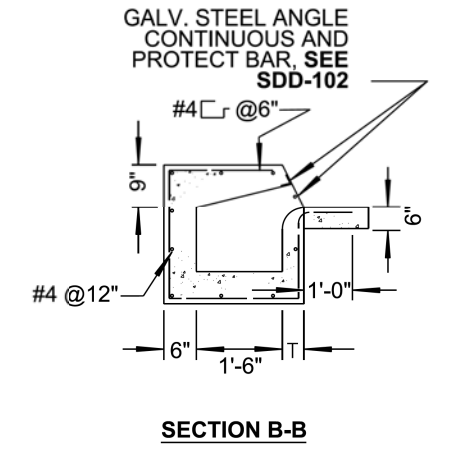
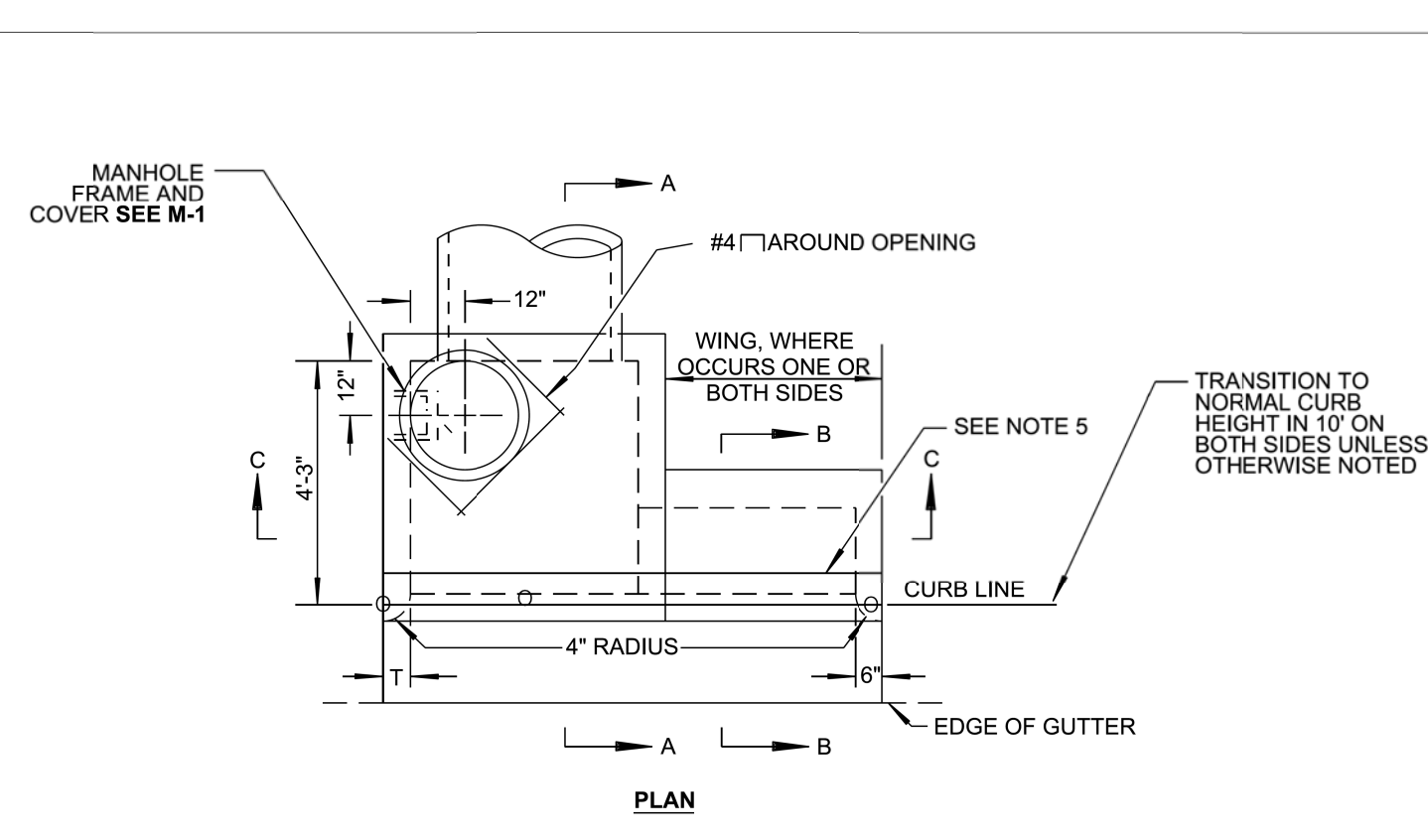

LEGEND ON PLANS

- NOTES**
1. TYPES ARE DESIGNATED AS FOLLOWS: (NO WING)B-1, (ONE WING)B-1, (TWO WINGS)B-2.
 2. EXPOSED EDGES OF CONCRETE SHALL BE ROUNDED WITH A RADIUS OF 1/2".
 3. WHEN V EXCEEDS 4', STEPS SHALL BE INSTALLED.
 4. CONCRETE GUTTER TO MATCH ADJACENT GUTTERS.
 5. AN EXPANSION JOINT SHALL BE PLACED AT THE ENDS OF THE INLET WHERE THE CURB IS TO ADJOIN PER G-10.
 6. PROVIDE 1/4" TOOLED GROOVE IN TOP SLAB IN LINE WITH BACK OF ADJACENT CURB.
 7. SURFACE OF TOP SLAB SHALL BE SIDEWALK FINISHED TO DRAIN TOWARD STREET AT A SLOPE OF 1/4" PER FOOT.
 8. ELEVATION SHALL BE SHOWN ON THE PLANS WHERE INDICATED "0" SYMBOL.
 9. SEE SDD-102 AND SDD-114 FOR ADDITIONAL NOTES AND DETAILS.

SHEET 2 OF 2

REVISION	BY	APPROVED	DATE
ORIGINAL	KA	J. NAGELVOORT	09/12
UPDATED	RE	J. NAGELVOORT	09/15
UPDATED	HN	J. NAGELVOORT	02/16
REDRAFTED	CD	J. NAGELVOORT	09/18

CITY OF SAN DIEGO - STANDARD DRAWING

RECOMMENDED BY THE CITY OF SAN DIEGO STANDARDS COMMITTEE

CAJunge 9/10/18
 COORDINATOR R.C.E. 5653 DATE

DRAWING NUMBER **SDD-116**

REVISION	BY	APPROVED	DATE
ORIGINAL	KA	J. NAGELVOORT	09/12
UPDATED	RE	J. NAGELVOORT	10/15
UPDATED	HN	J. NAGELVOORT	02/16
REDRAFTED	CD	J. NAGELVOORT	09/18
UPDATED	CD	J. NAGELVOORT	12/19

CITY OF SAN DIEGO - STANDARD DRAWING

RECOMMENDED BY THE CITY OF SAN DIEGO STANDARDS COMMITTEE

CAJunge 12/18/19
 COORDINATOR R.C.E. 5653 DATE

DRAWING NUMBER **SDD-116**

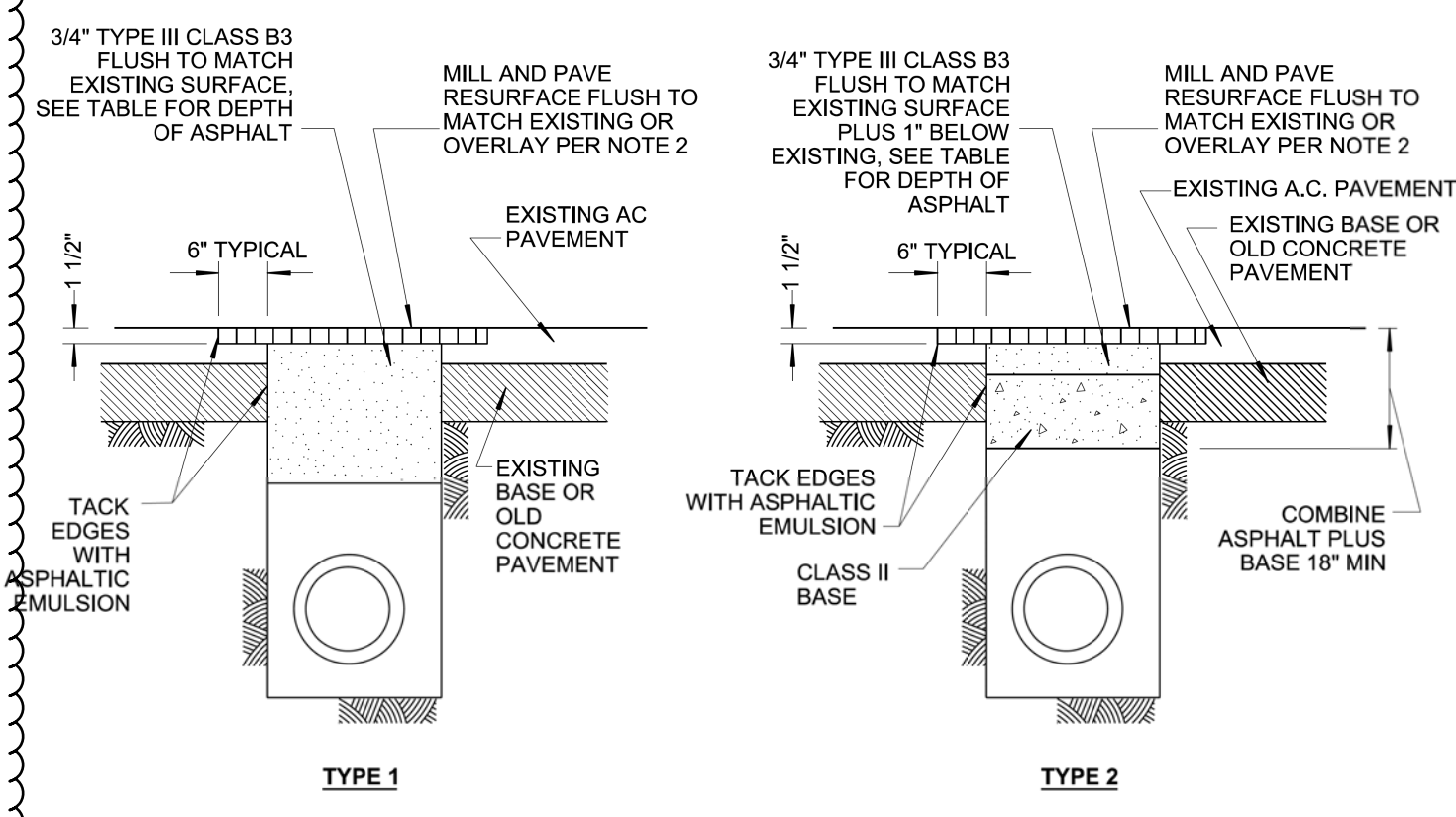

	TYPE 1	TYPE 2
MIX DESIGN	ASPHALT	ASPHALT PLUS BASE
ALLEYS	3/4" TYPE III CLASS B3	3/4" TYPE III CLASS B3 PLUS CLASS II BASE
LOCAL THROUGH 4 LANE COLLECTORS	8.0"	ASPHALT THICKNESS TO EQUAL
MAJOR	10.0"	EXISTING PLUS 1", MIN 4" TO MAX. 9".
	12.0"	COMBINED ASPHALT PLUS BASE 18" MIN.

- NOTES:**
1. ANY STREET TRENCH 7 FEET IN WIDTH OR GREATER AND LONGER THAN 100 FEET IN OVERALL LENGTH SHALL BE RECONSTRUCTED WITH THE PAVEMENT SECTION FOR THE STREET CLASSIFICATION PER SCHEDULE "J" (SDG-113).
 2. ASPHALT TRENCH CAPS IN STREETS NOT RECEIVING A FULL WIDTH OVERLAY PRIOR TO ACCEPTANCE SHALL BE MILLED AS SHOWN AND RESURFACED WITH 1/2" TYPE III CLASS C2 ASPHALT NO LESS THAN 30 CALENDAR DAYS AFTER INITIAL ASPHALT PLACEMENT.
 3. IF THE STREET IS NOT PLANNING TO DO CURB TO CURB SLURRY SEAL OR RESURFACING, IT MUST COMPLETE FINAL STREET RESTORATION WITHIN 60 DAYS AFTER THE INITIAL EXCAVATION.
 4. WHEN DIRECTED BY CITY ENGINEER OR SHOWN ON THE PLANS, CONCRETE PER SDG-108 (NOTE #5) MAY BE PLACED; A 1/8" - 1/4" WEARING SURFACING OF TYPE III CLASS F ASPHALT CONCRETE WILL BE REQUIRED.

SHEET 2 OF 2

REVISION	BY	APPROVED	DATE
ORIGINAL	J.P. CASEY		10/4/89
UPDATED	KA	J. NAGELVOORT	4/13
UPDATED	BB	J. NAGELVOORT	1/14
UPDATED	LS	J. NAGELVOORT	03/16
UPDATED	JN	J. NAGELVOORT	1/17
REDRAFTED	CD	J. NAGELVOORT	09/18

CITY OF SAN DIEGO - STANDARD DRAWING

RECOMMENDED BY THE CITY OF SAN DIEGO STANDARDS COMMITTEE

CAJunge 9/4/18
 COORDINATOR R.C.E. 5653 DATE

DRAWING NUMBER **SDG-107**

SCHEDULE "J" PAVEMENT

THE FOLLOWING TABLES ARE TO BE USED TO DETERMINE THE SCHEDULE "J" PAVEMENT DESIGN SECTIONS FOR STREETS, ALLEYS, PARKING LOTS FOR PUBLIC FACILITIES, DRIVEWAYS, AND EASEMENTS, INCLUDING PUBLIC ACCESS EASEMENTS. THESE DESIGNS SHALL BE USED IN THE PUBLIC RIGHT-OF-WAY, OR PRIVATE PROPERTY IN THE AREAS WHERE PUBLIC EASEMENTS ARE GRANTED.

1. RESISTANCE VALUES (R-VALUES) WILL BE DETERMINED FROM SAMPLES TAKEN FROM THE 12" MATERIAL LOCATED IMMEDIATELY BELOW THE FIRST LAYER OF SUBBASE, BASE OR PAVEMENT. THIS 12" SECTION SHALL REPRESENT THE TOP 36 INCHES OF UNIFORM SOILS BELOW THE SUBBASE OR PAVEMENT. IF A LOWER BEARING SOIL IS ENCOUNTERED IN THIS 36" SECTION, THE R-VALUE WILL BE DETERMINED FROM THE LOWEST BEARING SOIL. DETERMINATION OF THE R-VALUE SHALL BE IN ACCORDANCE WITH CALTRANS TEST METHODS 301-F AND 301-G.
2. AVERAGE DAILY TRAFFIC (ADT) IS THE MAXIMUM AVERAGE ANNUAL ADT EXPECTED AT BUILDOUT. FUNCTION SHALL ALSO BE CONSIDERED WHEN DETERMINING THE MINIMUM SCHEDULE "J" PAVEMENT SECTION PER THE ENGINEER.
3. RIGID PAVEMENTS: THE DESIGN THICKNESS SHOWN IN THE TABLES ARE BASED ON A MODIFIED PORTLAND CEMENT ASSOCIATION (PCA) DESIGN. PROJECTS REQUIRING CALTRANS REVIEW SHOULD UTILIZE THE DESIGN METHODS PRESCRIBED IN THE CALTRANS HIGHWAY DESIGN MANUAL.
4. CONCRETE PAVEMENT SHALL BE CONSTRUCTED IN STREETS ON GRADES GREATER THAN 12.0 PERCENT AND IN ALLEYS AND IN ALLEY INTERSECTIONS. THE PAVEMENT SHALL BE CLASS 560-B-3250 CONCRETE WITH A MINIMUM MODULES OF RUPTURE (MOR) OF 600.
5. NEW PAVEMENT, LESS THAN 6' IN WIDTH SHALL BE PAVED WITH PORTLAND CEMENT CONCRETE PAVEMENT SECTION NOTED IN SCHEDULE "J" FOR THE STREET CLASSIFICATION PLUS A 1/8" TO 1/4" CLASS F ASPHALT CONCRETE CAP. AN EQUIVALENT SECTION OF LEAN CONCRETE SHALL BE SUBSTITUTED FOR ANY REQUIRED CTB SUBBASE.
6. PERSONNEL FROM THE CITY'S ENGINEERING LABORATORY WILL DESIGNATE WHERE A PRIVATE LABORATORY SHALL SAMPLE FOR R-VALUES.

SHEET 1 OF 4

REVISION	BY	APPROVED	DATE
ORIGINAL	MJRODLINGER		05/92
NOTES	G. FARRINGTON		03/95
UPDATED	KA	J. NAGELVOORT	01/12
REDRAFTED	CD	J. NAGELVOORT	09/18

CITY OF SAN DIEGO - STANDARD DRAWING

RECOMMENDED BY THE CITY OF SAN DIEGO STANDARDS COMMITTEE

CAJunge 9/4/18
 COORDINATOR R.C.E. 5653 DATE

DRAWING NUMBER **SDG-113**

RICK ENGINEERING COMPANY
 5620 FRIARS ROAD
 SAN DIEGO, CA 92110
 619-291-0707
 (FAX) 619-291-4165
 rickengineering.com
 San Diego Riverside - Orange - Sacramento - San Luis Obispo - Phoenix - Tucson - Denver

J-17721

Karen S. Van Ert
 KAREN S. VAN ERT R.C.E. 56991 EXP. 6-30-2021
 10-15-2019 DATE

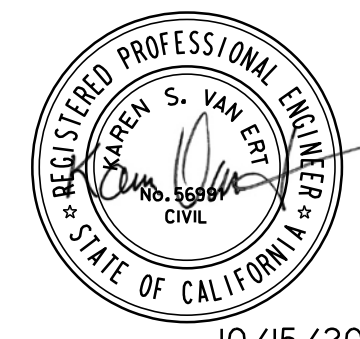

WANGENHEIM NEIGHBORHOOD JOINT USE FACILITY

DETAILS

CITY OF SAN DIEGO, CALIFORNIA
 PUBLIC WORKS DEPARTMENT
 SHEET 43 OF 142 SHEETS

WBS S-15007

APPROVED: *Jason Grant* 10/13/2020
 FOR CITY ENGINEER JASON GRANI DATE 77208
 PRINT NAME RCE#

SUBMITTED BY: YOVANNA LEWIS PROJECT MANAGER
 CHECKED BY: MEHDI RASHIDPOUR-HARISI PROJECT ENGINEER

DESCRIPTION	BY	APPROVED	DATE	FILMED
ORIGINAL	REC			
ADDENDUM B	REC	<i>SS</i>	1/11/2021	

1910-6291
 CCS83 COORDINATE

CONTRACTOR INSPECTOR DATE STARTED DATE COMPLETED

40846-43-D

IDENTIFICATION STAMP
 DIV. OF THE STATE ARCHITECT
 APP. 04-118244 INC:
 REVIEWED FOR
 SS FLS ACS
 DATE: 02.14.2020

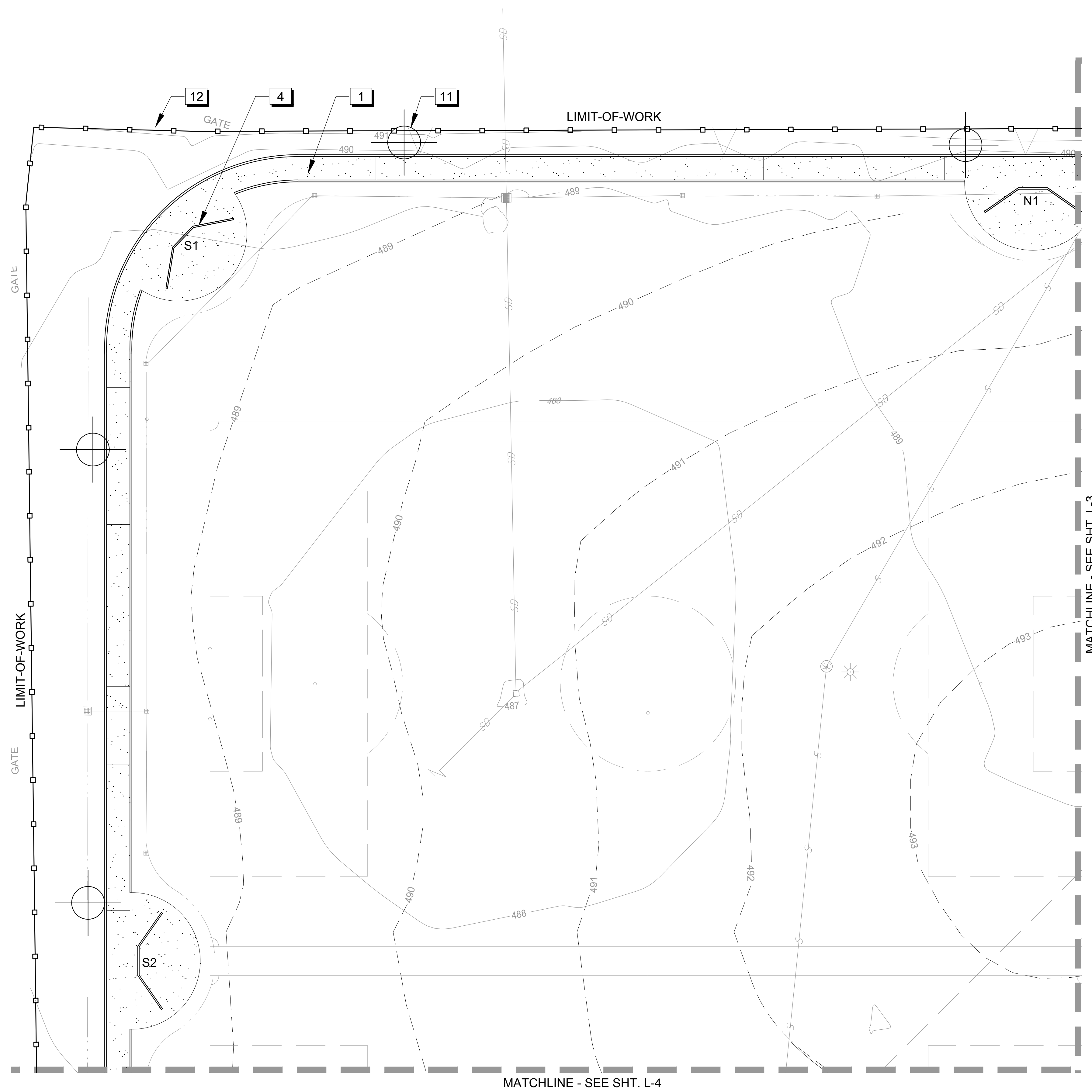

SITE LEGEND:

DESCRIPTION	DETAIL / SHEET	QUANTITY THIS SHT.
1 NEW MULTI-USE D.G. TRAIL	A / L-6	PLAN
2 NEW RESTROOM / CONCESSION BUILDING SEE ARCHITECTURAL AND MEP PLANS TYP.	-	-
3 NEW CITY STANDARD BACKSTOP & DUGOUT	B / L-6 C-G / L-7	0
4 PRACTICE BACKSTOP SALVAGE (S), NEW (N)	-	2 (S), 1 (N)
5 EXISTING ELECTRICAL TRANSFORMER, PROTECT IN PLACE.	-	-
6 EXISTING TREES PIP, TYP.	-	-
7 NEW SHADE SAILS OVER TOT-LOT	O-1 THRU O-6	0
8 NEW BLEACHERS	N / L-9	0
9 NEW PAIR OF TRASH/RECYCLING RECEPTACLES (ON CONCRETE PAD)	O / L-9	0
10 NEW CONCRETE SIDEWALK, SEE CIVIL PLANS		
11 NEW LIGHT FIXTURE, SEE ELECTRICAL PLANS TYP.		
12 EXISTING 10' HIGH FENCING TO REMAIN, PIP.		
13 A - EXISTING VEHICULAR GATE TO REMAIN, PIP. B - EXISTING VEHICULAR GATE TO BE SALVAGED AND RELOCATED PER PLAN.		
14 NEW FENCING AND GATES		
A - NEW 10' HIGH CHAIN LINK FENCE TYP.	K,L,M / L-8	PLAN
B - NEW 4' WIDE, SINGLE PEDESTRIAN GATE	H / L-7	0
C - NEW 24' WIDE, DOUBLE CHAIN LINK VEH. GATE	J / L-8	0
D - NEW 3' WIDE x 4' HIGH BLACK VINYL CHAIN LINK GATE W/ STANDARD (NON-ADA) LOCKING FORK LATCH. NO ADA SIGNAGE.	I,J / L-8	0
E - NEW 12' WIDE, DOUBLE ACCESS MAINT. GATE (NON-ADA)	J / L-7	0
F - NEW 4' HIGH BLACK VINYL CHAIN LINK FENCE INSTALL ON TOP OF CMU WALL, CORE & EPOXY SET FENCE POSTS	I / L-8	PLAN
G - NEW 8' WIDE, DOUBLE PEDESTRIAN GATE	H / L-7	0
NOTE: ALL NEW FENCING & GATES TO BE 10'-0" HIGH UNLESS OTHERWISE NOTED OR DETAILED.		
15 NEW INFIELD MIX, SEE FINISH SCHEDULE		
16 NEW PARKING LOT, SEE CIVIL PLANS		
17 NEW WATER QUALITY BASIN, SEE CIVIL PLANS		
18 NEW BENCH, TYP. (ON CONCRETE PAD PER CIVIL PLANS)	Q / L-9	0
19 NEW PICNIC TABLE - 2 ACCESSIBLE / 1 STANDARD; POUR THICKENED CONCRETE AT TABLES TO RECEIVE ANCHOR BOLTS TYP.	R / L-9	0
20 NEW BIKE RACK, TYP.	P / L-9	0
21 NEW ASSISTIVE LISTENING SIGNAGE (ON FENCE WHERE SHOWN) SEE FINISH SCHEDULE	-	-

- CONSTRUCTION NOTES:**
- ALL SYMBOLS ARE TYPICAL.
 - FOR CONSTRUCTION DETAILS SEE SHTS. L-6 THRU L-9.
 - FOR FINISH SCHEDULE, SEE SHT. L-6.
 - FOR ALL HORIZONTAL AND VERTICAL CONTROL SEE CIVIL PLANS.
 - FOR DRAINAGE PLAN, SEE CIVIL SHTS.
 - NEW PRACTICE BACKSTOPS TO MATCH EXISTING BACKSTOPS.

L-1

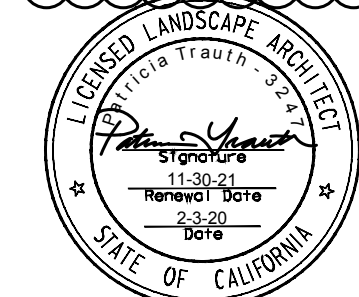

**WANGENHEIM NEIGHBORHOOD
 JOINT USE FACILITY
 LANDSCAPE CONSTRUCTION PLANS**

SPEC. NO.	CITY OF SAN DIEGO, CALIFORNIA PUBLIC WORKS DEPARTMENT SHEET 46 OF 142 SHEETS	WBS S-15007
APPROVED: FOR CITY ENGINEER JASON GRANI PRINT NAME	10/13/2020 DATE 77208 RCE#	SUBMITTED BY: YOVANNA LEWIS PROJECT MANAGER
REGISTERED PROFESSIONAL ENGINEER NO. C77208 CIVIL STATE OF CALIFORNIA	MEHDI RASHIDPOUR-HARISI PROJECT ENGINEER	270-1731 (NAD27) CCS27 COORDINATE
DESCRIPTION	BY	APPROVED
ORIGINAL	REC	
ADDENDUM B	REC	1/11/2021
1910-6291 (NAD83) CCS83 COORDINATE		
CONTRACTOR	DATE STARTED	40846-46-D
INSPECTOR	DATE COMPLETED	

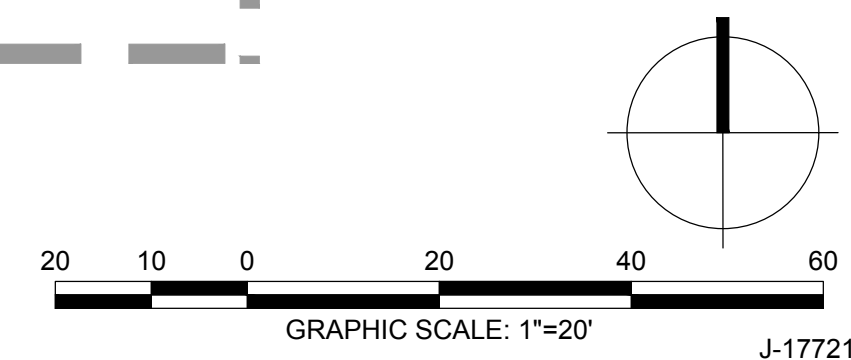

100%_DSD_2-4-2020

RICK ENGINEERING COMPANY
 5620 FRIARS ROAD
 SAN DIEGO, CA 92110
 619-291-0707
 (FAX) 619-291-4165
 rickengineering.com
 Riverside - Orange - Sacramento - San Luis Obispo - Phoenix - Tucson - Denver

IDENTIFICATION STAMP
 DIV. OF THE STATE ARCHITECT
 APP. 04-118244 INC.
 REVIEWED FOR
 SS FLS ACS
 DATE: 02.14.2020

SITE LEGEND:

DESCRIPTION	DETAIL / SHEET	QUANTITY THIS SHT.
1 NEW MULTI-USE D.G. TRAIL	A / L-6	
2 NEW RESTROOM / CONCESSION BUILDING SEE ARCHITECTURAL AND MEP PLANS TYP.	-	
3 NEW CITY STANDARD BACKSTOP & DUGOUT	B / L-6 C-G / L-7	0
4 PRACTICE BACKSTOP SALVAGE (S), NEW (N)	-	0
5 EXISTING ELECTRICAL TRANSFORMER, PROTECT IN PLACE.	-	-
6 EXISTING TREES PIP, TYP.	-	-
7 NEW SHADE SAILS OVER TOT-LOT	O-1 THRU O-6	3
8 NEW BLEACHERS	N / L-9	0
9 NEW PAIR OF TRASH/RECYCLING RECEPTACLES (ON CONCRETE PAD)	O / L-9	0
10 NEW CONCRETE SIDEWALK, SEE CIVIL PLANS		
11 NEW LIGHT FIXTURE, SEE ELECTRICAL PLANS TYP.		
12 EXISTING 10' HIGH FENCING TO REMAIN, PIP.		
13 A - EXISTING VEHICULAR GATE TO REMAIN, PIP. B - EXISTING VEHICULAR GATE TO BE SALVAGED AND RELOCATED PER PLAN.		
14 NEW FENCING AND GATES		
A - NEW 10' HIGH CHAIN LINK FENCE TYP.	K,L,M / L-8	PLAN
B - NEW 4' WIDE, SINGLE PEDESTRIAN GATE	H / L-7	0
C - NEW 24' WIDE, DOUBLE CHAIN LINK VEH. GATE	J / L-8	0
D - NEW 3' WIDE x 4' HIGH BLACK VINYL CHAIN LINK GATE W/ STANDARD (NON-ADA) LOCKING FORK LATCH. NO ADA SIGNAGE.	I,J / L-8	0
E - NEW 12' WIDE, DOUBLE ACCESS MAINT. GATE (NON-ADA)	J / L-7	0
F - NEW 4' HIGH BLACK VINYL CHAIN LINK FENCE INSTALL ON TOP OF CMU WALL, CORE & EPOXY SET FENCE POSTS	I / L-8	PLAN
G - NEW 8' WIDE, DOUBLE PEDESTRIAN GATE	H / L-7	0
NOTE: ALL NEW FENCING & GATES TO BE 10'-0" HIGH UNLESS OTHERWISE NOTED OR DETAILED.		
15 NEW INFIELD MIX, SEE FINISH SCHEDULE		
16 NEW PARKING LOT, SEE CIVIL PLANS		
17 NEW WATER QUALITY BASIN, SEE CIVIL PLANS		
18 NEW BENCH, TYP. (ON CONCRETE PAD PER CIVIL PLANS)	Q / L-9	0
19 NEW PICNIC TABLE - 2 ACCESSIBLE / 1 STANDARD; POUR THICKENED CONCRETE AT TABLES TO RECEIVE ANCHOR BOLTS TYP.	R / L-9	0
20 NEW BIKE RACK, TYP.	P / L-9	0
21 NEW ASSISTIVE LISTENING SIGNAGE (ON FENCE WHERE SHOWN) SEE FINISH SCHEDULE	-	-

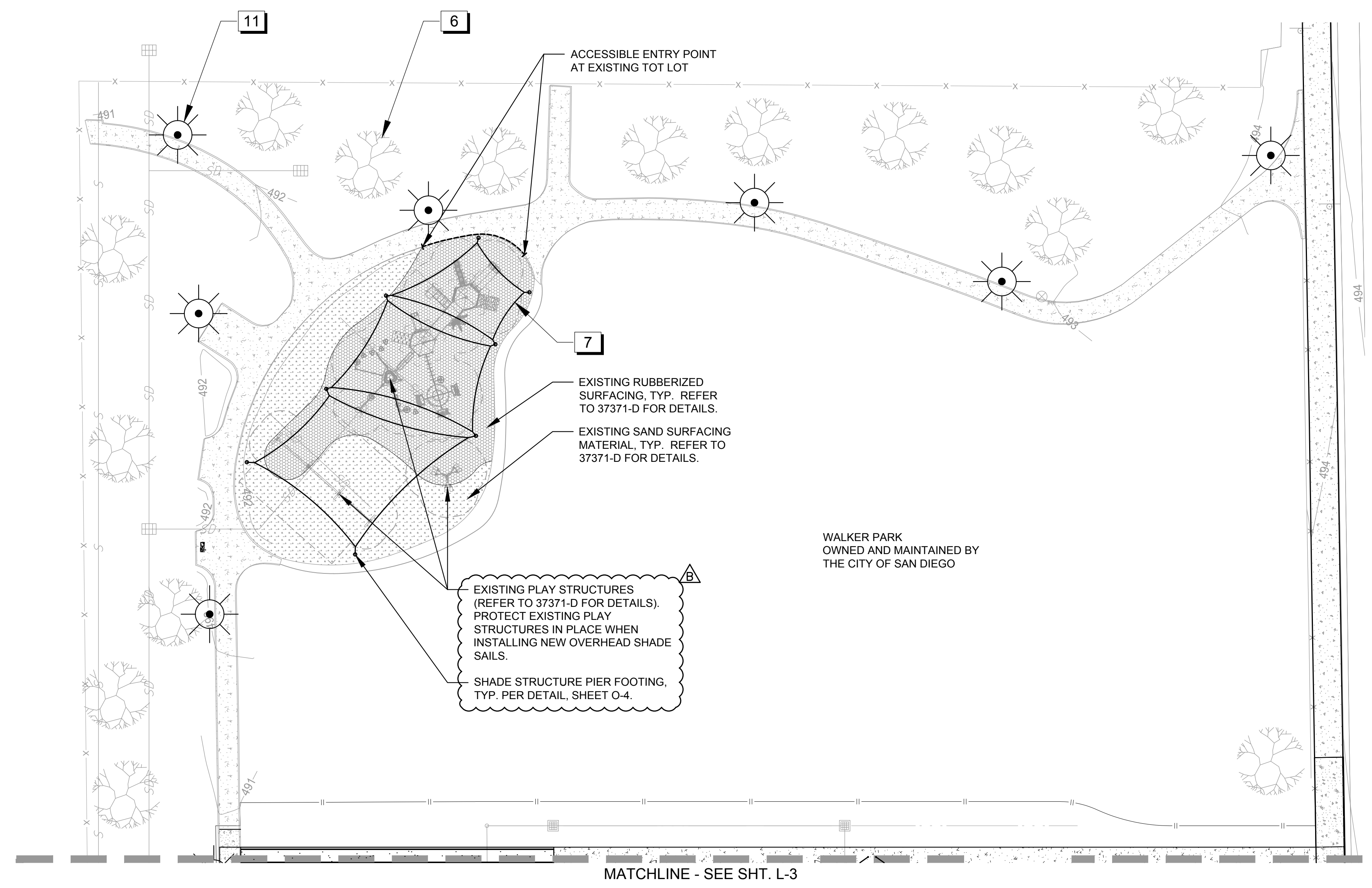

- SHADE SAIL CONSTRUCTION NOTES:**
- CONTRACTOR SHALL PROTECT IN PLACE ALL EXISTING TOT-LOT EQUIPMENT, SURFACING (SAND OR RUBBERIZED), SIDEWALK AND CONCRETE EDGE.
 - CONTRACTOR SHALL RESTORE ANY TOT-LOT SURFACING TOT-LOT EQUIPMENT OR CONCRETE FLATWORK TO ITS ORIGINAL CONDITION AS PART OF SHADE SAIL INSTALLATION, AS REQUIRED.
 - CONTRACTOR SHALL PROTECT IN PLACE ALL EXISTING TURF AND IRRIGATION SYSTEMS DURING SHADE SAIL INSTALLATION.
 - CONTRACTOR SHALL RESTORE ANY DAMAGE TO EXISTING TURF OR IRRIGATION SYSTEMS TO ITS ORIGINAL CONDITION AS PART OF SHADE SAIL INSTALLATION, AS REQUIRED.
 - PRIOR TO EXCAVATION, CONTRACTOR SHALL POT-HOLE AT PROPOSED SAIL SUPPORT LOCATION(S) WITHIN SAND AREA TO DETERMINE WHERE EXISTING DRAIN LINES ARE ROUTED. CONTRACTOR SHALL RE-ROUTE ANY DRAIN LINES WITH POSITIVE DRAINAGE AS REQUIRED.

- SITE LIGHTING NOTES:**
- CONTRACTOR SHALL PROTECT IN PLACE ALL EXISTING SHRUBS AND IRRIGATION SYSTEM DURING INSTALLATION OF SITE LIGHTING AND ELECTRICAL CONDUIT.
 - CONTRACTOR SHALL RESTORE EXISTING SHRUBS OR IRRIGATION SYSTEM TO THEIR ORIGINAL CONDITION IF DAMAGED DURING INSTALLATION OF SITE LIGHTING AND ELECTRICAL CONDUIT, AS REQUIRED.
 - PRIOR TO EXCAVATION, CONTRACTOR SHALL POT-HOLE AT PROPOSED SIGHT LIGHTING LOCATION(S) AND ELECTRICAL CONDUIT TO DETERMINE WHERE EXISTING IRRIGATION AND/OR UTILITIES ARE LOCATED. CONTRACTOR SHALL RESTORE ANY IRRIGATION OR UTILITY LINES TO THEIR ORIGINAL CONDITION IF DAMAGED, AS REQUIRED.

- CONSTRUCTION NOTES:**
- ALL SYMBOLS ARE TYPICAL.
 - FOR CONSTRUCTION DETAILS SEE SHTS. L-6 THRU L-9.
 - FOR FINISH SCHEDULE, SEE SHT. L-6.
 - FOR ALL HORIZONTAL AND VERTICAL CONTROL SEE CIVIL PLANS.
 - FOR DRAINAGE PLAN, SEE CIVIL SHTS.
 - NEW PRACTICE BACKSTOPS TO MATCH EXISTING BACKSTOPS.

100%_DSD_2-4-2020

RICK ENGINEERING COMPANY
 5620 FRIARS ROAD
 SAN DIEGO, CA 92110
 619-291-0707
 (FAX) 619-291-4165
 rickengineering.com
 San Diego Riverside - Orange - Sacramento - San Luis Obispo - Phoenix - Tucson - Denver

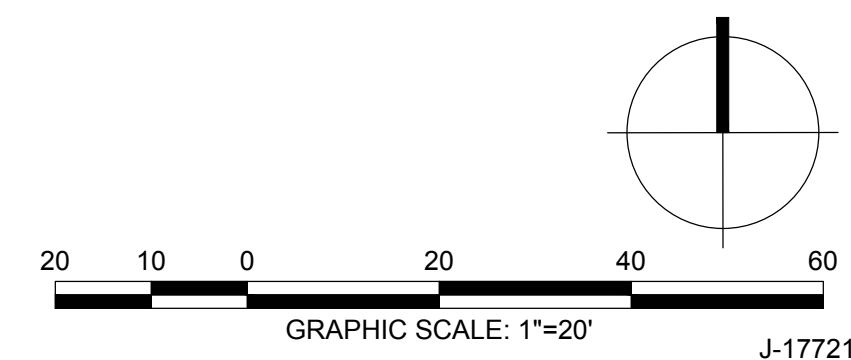

WANGENHEIM NEIGHBORHOOD JOINT USE FACILITY
LANDSCAPE CONSTRUCTION PLANS

CITY OF SAN DIEGO, CALIFORNIA
 PUBLIC WORKS DEPARTMENT
 SHEET 47 OF 142 SHEETS

WBS S-15007

APPROVED: *Jason Grani* 10/13/2020
 FOR CITY ENGINEER DATE
 JASON GRANI PROJECT MANAGER
 PRINT NAME RCE# 77208

CREATED BY: MEHDI RASHIDPOUR-HARISI
 PROJECT ENGINEER

DESCRIPTION	BY	APPROVED	DATE	FILMED
ORIGINAL	REC			
ADDENDUM B	REC	<i>SS</i>	1/11/2021	

1910-6291 (NAD83)
 CCS83 COORDINATE

CONTRACTOR: _____ DATE STARTED: _____
 INSPECTOR: _____ DATE COMPLETED: _____

40846-47-D

IDENTIFICATION STAMP
 DIV. OF THE STATE ARCHITECT
 APP. 04-118244 INC. REVIEWED FOR
 SS FLS ACS
 DATE: 02.14.2020

SITE LEGEND:

DESCRIPTION	DETAIL / SHEET	QUANTITY THIS SHT.
1 NEW MULTI-USE D.G. TRAIL	A / L-6	
2 NEW RESTROOM / CONCESSION BUILDING SEE ARCHITECTURAL AND MEP PLANS TYP.	-	
3 NEW CITY STANDARD BACKSTOP & DUGOUT	B / L-6 C-G / L-7	1
4 PRACTICE BACKSTOP SALVAGE (S), NEW (N)	-	0
5 EXISTING ELECTRICAL TRANSFORMER, PROTECT IN PLACE.	-	-
6 EXISTING TREES PIP, TYP.	-	-
7 NEW SHADE SAILS OVER TOT-LOT	O-1 THRU O-6	0
8 NEW BLEACHERS	N / L-9	2
9 NEW PAIR OF TRASH/RECYCLING RECEPTACLES (ON CONCRETE PAD)	O / L-9	2
10 NEW CONCRETE SIDEWALK, SEE CIVIL PLANS	C-19	
11 NEW LIGHT FIXTURE, SEE ELECTRICAL PLANS TYP.		
12 EXISTING 10' HIGH FENCING TO REMAIN, PIP.		
13 A - EXISTING VEHICULAR GATE TO REMAIN, PIP. B - EXISTING VEHICULAR GATE TO BE SALVAGED AND RELOCATED PER PLAN.		
14 NEW FENCING AND GATES		
A - NEW 10' HIGH CHAIN LINK FENCE TYP.	K,L,M / L-8	PLAN
B - NEW 4' WIDE, SINGLE PEDESTRIAN GATE	H / L-7	0
C - NEW 24' WIDE, DOUBLE CHAIN LINK VEH. GATE	J / L-8	0
D - NEW 3' WIDE x 4' HIGH BLACK VINYL CHAIN LINK GATE W/ STANDARD (NON-ADA) LOCKING FORK LATCH. NO ADA SIGNAGE.	I,J / L-8	0
E - NEW 12' WIDE, DOUBLE ACCESS MAINT. GATE (NON-ADA)	J / L-7	1
F - NEW 4' HIGH BLACK VINYL CHAIN LINK FENCE INSTALL ON TOP OF CMU WALL, CORE & EPOXY SET FENCE POSTS	I / L-8	PLAN
G - NEW 8' WIDE, DOUBLE PEDESTRIAN GATE	H / L-7	2
NOTE: ALL NEW FENCING & GATES TO BE 10'-0" HIGH UNLESS OTHERWISE NOTED OR DETAILED.		1
15 NEW INFIELD MIX, SEE FINISH SCHEDULE		
16 NEW PARKING LOT, SEE CIVIL PLANS		
17 NEW WATER QUALITY BASIN, SEE CIVIL PLANS		
18 NEW BENCH, TYP. (ON CONCRETE PAD PER CIVIL PLANS)	Q / L-9	0
19 NEW PICNIC TABLE - 2 ACCESSIBLE / 1 STANDARD; POUR THICKENED CONCRETE AT TABLES TO RECEIVE ANCHOR BOLTS TYP.	R / L-9	3
20 NEW BIKE RACK, TYP.	P / L-9	1
21 NEW ASSISTIVE LISTENING SIGNAGE (ON FENCE WHERE SHOWN) SEE FINISH SCHEDULE	-	2

- CONSTRUCTION NOTES:**
- ALL SYMBOLS ARE TYPICAL.
 - FOR CONSTRUCTION DETAILS SEE SHTS. L-6 THRU L-9.
 - FOR FINISH SCHEDULE, SEE SHT. L-6.
 - FOR ALL HORIZONTAL AND VERTICAL CONTROL SEE CIVIL PLANS.
 - FOR DRAINAGE PLAN, SEE CIVIL SHTS.
 - NEW PRACTICE BACKSTOPS TO MATCH EXISTING BACKSTOPS.

L-3

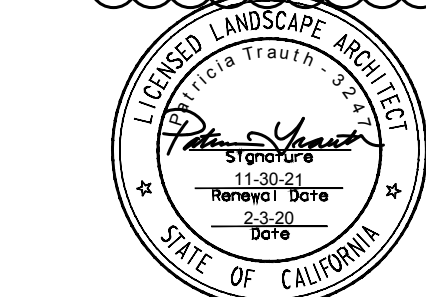

**WANGENHEIM NEIGHBORHOOD
JOINT USE FACILITY
LANDSCAPE CONSTRUCTION PLANS**

SPEC. NO.	CITY OF SAN DIEGO, CALIFORNIA PUBLIC WORKS DEPARTMENT SHEET 48 OF 142 SHEETS	WBS S-15007
APPROVED: FOR CITY ENGINEER JASON GRANT PRINT NAME	DATE 10/13/2020 DATE 77208 RCE#	SUBMITTED BY: YOVANNA LEWIS PROJECT MANAGER
REGISTERED PROFESSIONAL ENGINEER CIVIL NO. C77208 STATE OF CALIFORNIA	DESCRIPTION BY APPROVED DATE FILMED	CHECKED BY: MEHDI RASHIDPOUR-HARISI PROJECT ENGINEER
ORIGINAL REC	270-1731 (NAD27)	1910-6291 (NAD83)
ADDENDUM B REC	CCS27 COORDINATE	CCS83 COORDINATE
CONTRACTOR	DATE STARTED	40846-48-D
INSPECTOR	DATE COMPLETED	

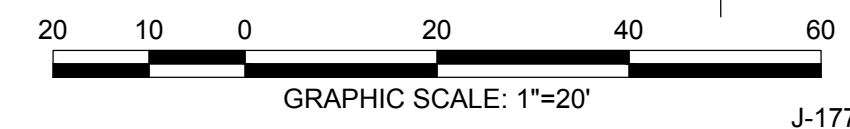
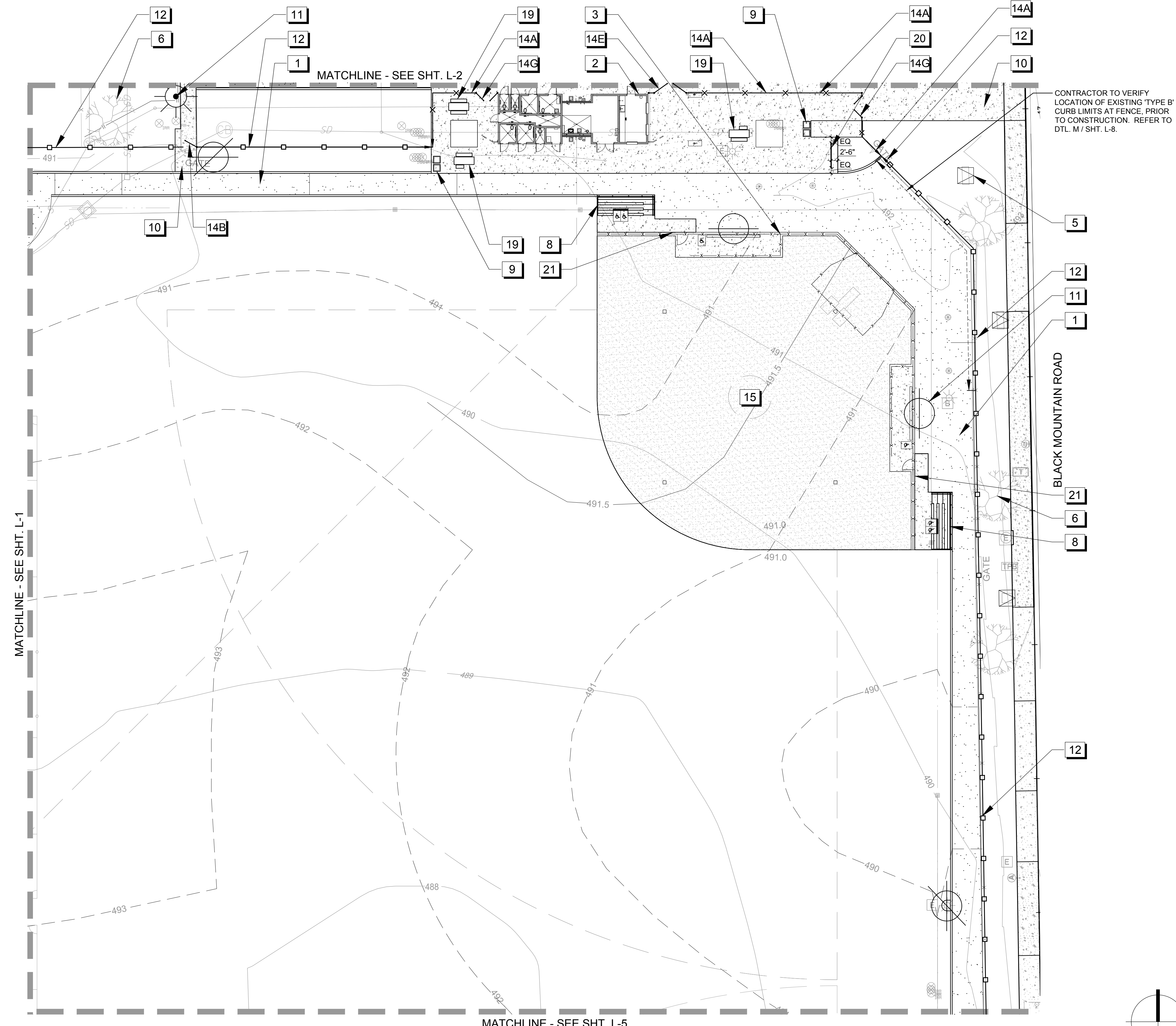

100%_DSD_2-4-2020

RICK
ENGINEERING COMPANY
5620 FRIARS ROAD
SAN DIEGO, CA 92110
619-291-0707
(FAX) 619-291-4165
rickengineering.com

Riverside - Orange - Sacramento - San Luis Obispo - Phoenix - Tucson - Denver

IDENTIFICATION STAMP
 DIV. OF THE STATE ARCHITECT
 APP. 04-118244 INC.
 REVIEWED FOR
 SS FLS ACS
 DATE: 02.14.2020

SITE LEGEND:

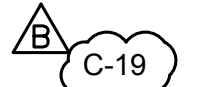
DESCRIPTION	DETAIL / SHEET	QUANTITY THIS SHT.
1 NEW MULTI-USE D.G. TRAIL	A / L-6	
2 NEW RESTROOM / CONCESSION BUILDING SEE ARCHITECTURAL AND MEP PLANS TYP.	-	
3 NEW CITY STANDARD BACKSTOP & DUGOUT	B / L-6 C-G / L-7	0
4 PRACTICE BACKSTOP SALVAGE (S), NEW (N)	-	2 (S), 0 (N)
5 EXISTING ELECTRICAL TRANSFORMER, PROTECT IN PLACE.	-	-
6 EXISTING TREES PIP, TYP.	-	-
7 NEW SHADE SAILS OVER TOT-LOT	O-1 THRU O-6	0
8 NEW BLEACHERS	N / L-9	0
9 NEW PAIR OF TRASH/RECYCLING RECEPTACLES (ON CONCRETE PAD)	O / L-9	2
10 NEW CONCRETE SIDEWALK, SEE CIVIL PLANS	 C-19	
11 NEW LIGHT FIXTURE, SEE ELECTRICAL PLANS TYP.		
12 EXISTING 10' HIGH FENCING TO REMAIN, PIP.		
13 A - EXISTING VEHICULAR GATE TO REMAIN, PIP. B - EXISTING VEHICULAR GATE TO BE SALVAGED AND RELOCATED PER PLAN.		1
14 NEW FENCING AND GATES		
A - NEW 10' HIGH CHAIN LINK FENCE TYP.	K,L,M / L-8	PLAN
B - NEW 4' WIDE, SINGLE PEDESTRIAN GATE	H / L-7	1
C - NEW 24' WIDE, DOUBLE CHAIN LINK VEH. GATE	J / L-8	1
D - NEW 3' WIDE x 4' HIGH BLACK VINYL CHAIN LINK GATE W/ STANDARD (NON-ADA) LOCKING FORK LATCH. NO ADA SIGNAGE.	I,J / L-8	1
E - NEW 12' WIDE, DOUBLE ACCESS MAINT. GATE (NON-ADA)	J / L-7	0
F - NEW 4' HIGH BLACK VINYL CHAIN LINK FENCE INSTALL ON TOP OF CMU WALL, CORE & EPOXY SET FENCE POSTS	I / L-8	PLAN
G - NEW 8' WIDE, DOUBLE PEDESTRIAN GATE	H / L-7	1
NOTE: ALL NEW FENCING & GATES TO BE 10'-0" HIGH UNLESS OTHERWISE NOTED OR DETAILED.		0
15 NEW INFIELD MIX, SEE FINISH SCHEDULE		
16 NEW PARKING LOT, SEE CIVIL PLANS		
17 NEW WATER QUALITY BASIN, SEE CIVIL PLANS		
18 NEW BENCH, TYP. (ON CONCRETE PAD PER CIVIL PLANS)	Q / L-9	0
19 NEW PICNIC TABLE - 2 ACCESSIBLE / 1 STANDARD; POUR THICKENED CONCRETE AT TABLES TO RECEIVE ANCHOR BOLTS TYP.	R / L-9	0
20 NEW BIKE RACK, TYP.	P / L-9	1
21 NEW ASSISTIVE LISTENING SIGNAGE (ON FENCE WHERE SHOWN) SEE FINISH SCHEDULE	-	-

- CONSTRUCTION NOTES:**
- ALL SYMBOLS ARE TYPICAL.
 - FOR CONSTRUCTION DETAILS SEE SHTS. L-6 THRU L-9.
 - FOR FINISH SCHEDULE, SEE SHT. L-6.
 - FOR ALL HORIZONTAL AND VERTICAL CONTROL SEE CIVIL PLANS.
 - FOR DRAINAGE PLAN, SEE CIVIL SHTS.
 - NEW PRACTICE BACKSTOPS TO MATCH EXISTING BACKSTOPS.

- PAVEMENT MARKINGS:**
- ACCESSIBLE PARKING:**
 - ACCESSIBLE PARKING SPACES SERVING A PARTICULAR BUILDING OR FACILITY SHALL BE LOCATED ON THE SHORTEST ACCESSIBLE ROUTE TO AN ENTRANCE COMPLYING WITH **CBC SECTION 11B-208.3.1**.
 - ACCESSIBLE PARKING SPACES SERVING MORE THAN ONE ACCESSIBLE ENTRANCE SHALL BE DISPERSED AND LOCATED ON THE SHORTEST ACCESSIBLE ROUTE TO THE ACCESSIBLE ENTRANCES.
 - ACCESSIBLE PARKING SPACES IN A PARKING FACILITY NOT SERVING A PARTICULAR BUILDING OR FACILITY SHALL BE LOCATED ON THE SHORTEST ACCESSIBLE ROUTE TO AN ACCESSIBLE PEDESTRIAN ENTRANCE OF THE PARKING FACILITY. **CBC SECTION 11B-208.3.1**
 - MINIMUM NUMBER OF REQUIRED ACCESSIBLE PARKING SPACES SHALL BE PROVIDED IN ACCORDANCE WITH **CBC TABLE 11B-208.2** FOR EACH PARKING FACILITY PROVIDED ON A SITE.
 - FOR EVERY SIX OR FRACTION OF SIX ACCESSIBLE PARKING SPACES, AT LEAST ONE SHALL BE AN ACCESSIBLE VAN PARKING SPACE. **CBC SECTION 11B-208.4**
 - ACCESSIBLE PARKING SPACES AND ACCESS AISLES SHALL COMPLY WITH **CBC SECTION 11B-502** AND SHALL BE DIMENSIONED TO THE CENTERLINE OF THE MARKED LINES AS FOLLOWS:
 - PARKING SPACES AND ACCESS AISLES SHALL BE MARKED ACCORDING TO **CBC FIGURES 11B-502.2, 11B-502.3**. THEIR SURFACES SHALL COMPLY WITH **CBC SECTION 11B-302** AND SHALL BE AT THE SAME LEVEL WITH SLOPES NOT STEEPER THAN 1:48 IN ANY DIRECTION. **CBC SECTION 11B-502.4**
 - PARKING SPACES SHALL BE 9'X18' MINIMUM AND VAN PARKING SPACES SHALL BE 12'X18' MINIMUM WITH AN ADJACENT ACCESS AISLE OF 5'X18' MINIMUM. ACCESS AISLES SHALL BE PLACED ON EITHER SIDE OF THE PARKING SPACES EXCEPT BE LOCATED ON THE PASSENGER SIDE FOR VAN PARKING SPACES. VAN PARKING SPACES SHALL BE PERMITTED TO BE 9'X18' MINIMUM WHERE THE ACCESS AISLE IS 8'X18' MINIMUM.
 - ACCESS AISLES SHALL BE MARKED BY A BLUE PAINTED BORDERLINE AROUND THEIR PERIMETER. THE AREA WITHIN THE BLUE BORDERLINES SHALL BE MARKED WITH HATCHED LINES A MAXIMUM OF 36" ON CENTER IN A COLOR CONTRASTING WITH THAT OF THE AISLE SURFACE, PREFERABLY BLUE OR WHITE. ACCESS AISLE MARKINGS MAY EXTEND BEYOND THE MINIMUM REQUIRED LENGTH. **CBC SECTION 11B-502.3.3**
 - ACCESS AISLES (ACCESSIBLE PARKING SPACES AS WELL - SIMILAR APPLICATION) SHALL NOT OVERLAP WITH VEHICULAR WAY. **CBC SECTION 11B-502.3.4**
 - A VERTICAL CLEARANCE OF 8'-2" MINIMUM SHALL BE PROVIDED FOR ACCESSIBLE PARKING SPACES, ACCESS AISLES, AND VEHICULAR ROUTES SERVING THEM. **CBC SECTION 11B-502.5**
 - DETECTABLE WARNING SURFACES:**
 - DETECTABLE WARNING SURFACES SHALL COMPLY WITH **CBC SECTION 11B-705-1**.
 - DETECTABLE WARNING SURFACES AT TRANSIT BOARDING PLATFORM EDGES, BUS STOPS, HAZARDOUS VEHICULAR AREAS, REFLECTING POOLS, AND TRACK CROSSINGS SHALL BE YELLOW AND **APPROXIMATE FS 33538 OF FEDERAL STANDARD 595C**. DETECTABLE WARNING SURFACES AT OTHER LOCATIONS SHALL BE EITHER THE AFOREMENTIONED YELLOW OR A COLOR PROVIDING A 70 PERCENT MINIMUM VISUAL CONTRAST WITH THAT OF ADJACENT WALKING SURFACES. THE MATERIAL USED TO PROVIDE VISUAL CONTRAST SHALL BE AN INTEGRAL PART OF THE SURFACE. **CBC SECTION 11B-705.1.1.3**
 - DETECTABLE WARNING SURFACES SHALL DIFFER FROM ADJOINING SURFACES IN RESILIENCY OR SOUND-ON-CANE CONTACT. SUCH CONSTRAINT SHALL NOT BE REQUIRED FOR DETECTABLE WARNING SURFACES AT CURB RAMPS, ISLANDS, OR CUT-THROUGH MEDIANS. **CBC SECTION 11B-705.1.1.4**

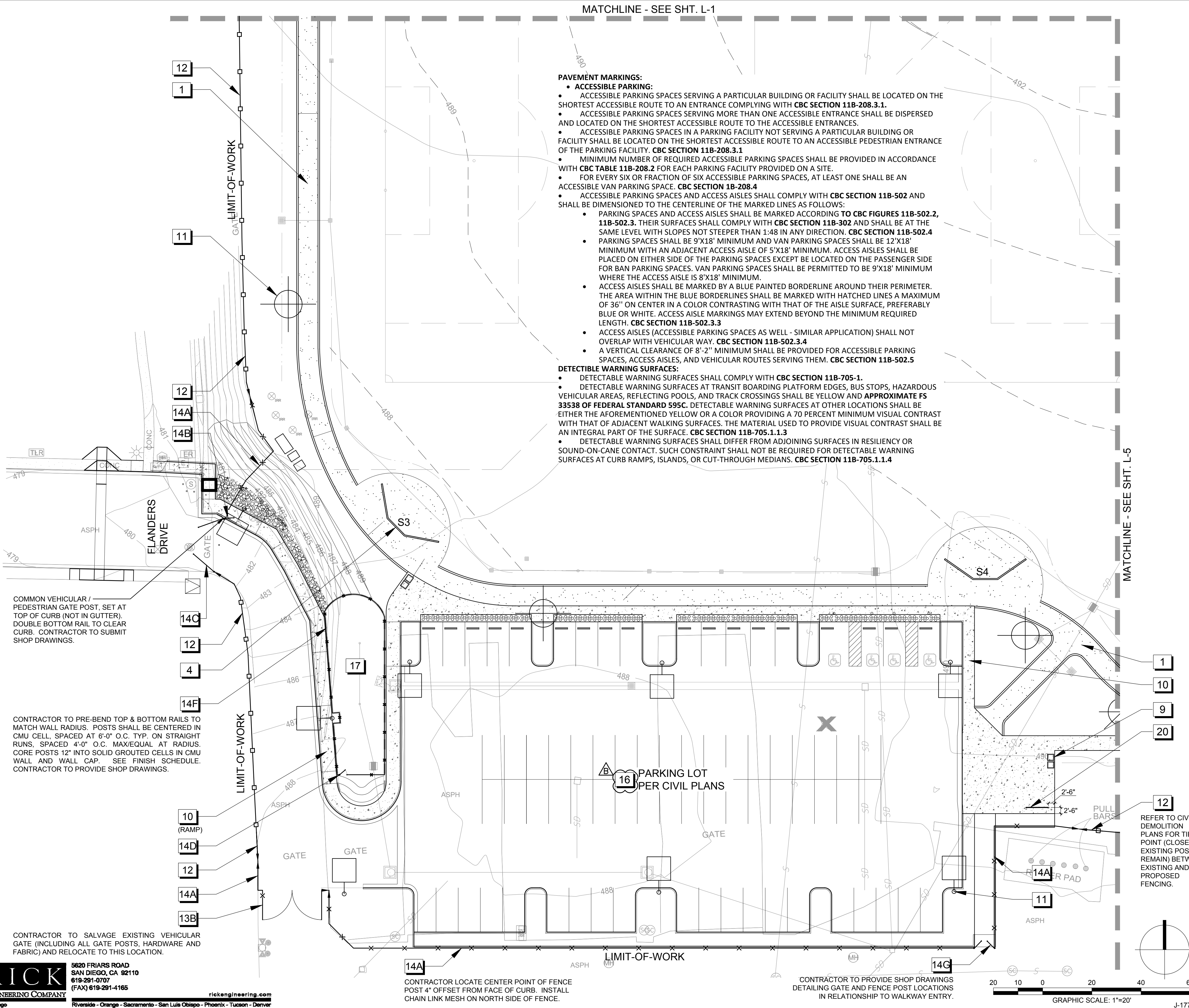

L-4

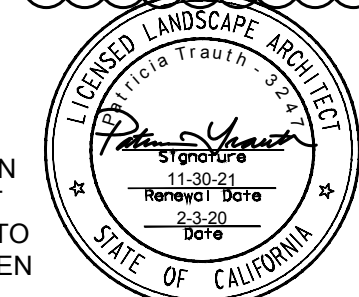

**WANGENHEIM NEIGHBORHOOD
JOINT USE FACILITY
LANDSCAPE CONSTRUCTION PLANS**

SPEC. NO.		CITY OF SAN DIEGO, CALIFORNIA PUBLIC WORKS DEPARTMENT SHEET 49 OF 142 SHEETS		WBS S-15007
APPROVED:	10/13/2020	DATE	77208	FOR CITY ENGINEER JASON GRANI
PRINT NAME	RCE#	DATE	1/11/2021	MEHDI RASHIDPOUR-HARISI PROJECT ENGINEER
DESCRIPTION	BY	APPROVED	DATE	FILMED
ORIGINAL	REC			
ADDENDUM B	REC			
1910-6291 (NAD83) CCS83 COORDINATE				40846-49-D
CONTRACTOR	INSPECTOR	DATE STARTED	DATE COMPLETED	

REFER TO CIVIL
DEMOLITION
PLANS FOR TIE-IN
POINT (CLOSEST
EXISTING POST TO
REMAIN) BETWEEN
EXISTING AND
PROPOSED
FENCING.

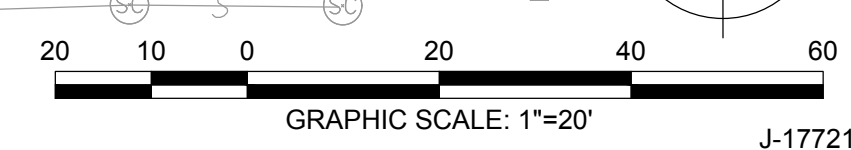

100%_DSD_2-4-2020

RICK ENGINEERING COMPANY
 5620 FRIARS ROAD
 SAN DIEGO, CA 92110
 619-291-0707
 (FAX) 619-291-4165
 rickengineering.com
 San Diego Riverside - Orange - Sacramento - San Luis Obispo - Phoenix - Tucson - Denver

CONTRACTOR LOCATE CENTER POINT OF FENCE
POST 4" OFFSET FROM FACE OF CURB. INSTALL
CHAIN LINK MESH ON NORTH SIDE OF FENCE.

CONTRACTOR TO PROVIDE SHOP DRAWINGS
DETAILING GATE AND FENCE POST LOCATIONS
IN RELATIONSHIP TO WALKWAY ENTRY.

IDENTIFICATION STAMP
 DIV. OF THE STATE ARCHITECT
 APP. 04-118244 INC.
 REVIEWED FOR
 SS FLS ACS
 DATE: 02.14.2020

SITE LEGEND:

DESCRIPTION	DETAIL / SHEET	QUANTITY THIS SHT.
1 NEW MULTI-USE D.G. TRAIL	A / L-6	
2 NEW RESTROOM / CONCESSION BUILDING SEE ARCHITECTURAL AND MEP PLANS TYP.	-	
3 NEW CITY STANDARD BACKSTOP & DUGOUT	B / L-6 C-G / L-7	1
4 PRACTICE BACKSTOP SALVAGE (S), NEW (N)	-	0
5 EXISTING ELECTRICAL TRANSFORMER, PROTECT IN PLACE.	-	-
6 EXISTING TREES PIP, TYP.	-	-
7 NEW SHADE SAILS OVER TOT-LOT	O-1 THRU O-6	0
8 NEW BLEACHERS	N / L-9	2
9 NEW PAIR OF TRASH/RECYCLING RECEPTACLES (ON CONCRETE PAD)	O / L-9	1
10 NEW CONCRETE SIDEWALK, SEE CIVIL PLANS		
11 NEW LIGHT FIXTURE, SEE ELECTRICAL PLANS TYP.		
12 EXISTING 10' HIGH FENCING TO REMAIN, PIP.		
A - EXISTING VEHICULAR GATE TO REMAIN, PIP. B - EXISTING VEHICULAR GATE TO BE SALVAGED AND RELOCATED PER PLAN.		1
14 NEW FENCING AND GATES		
A - NEW 10' HIGH CHAIN LINK FENCE TYP.	K,L,M / L-8	PLAN
B - NEW 4' WIDE, SINGLE PEDESTRIAN GATE	H / L-7	0
C - NEW 24' WIDE, DOUBLE CHAIN LINK VEH. GATE	J / L-8	0
D - NEW 3' WIDE x 4' HIGH BLACK VINYL CHAIN LINK GATE W/ STANDARD (NON-ADA) LOCKING FORK LATCH. NO ADA SIGNAGE.	I,J / L-8	0
E - NEW 12' WIDE, DOUBLE ACCESS MAINT. GATE (NON-ADA)	J / L-7	0
F - NEW 4' HIGH BLACK VINYL CHAIN LINK FENCE INSTALL ON TOP OF CMU WALL, CORE & EPOXY SET FENCE POSTS	I / L-8	PLAN
G - NEW 8' WIDE, DOUBLE PEDESTRIAN GATE	H / L-7	1
NOTE: ALL NEW FENCING & GATES TO BE 10'-0" HIGH UNLESS OTHERWISE NOTED OR DETAILED.		1
15 NEW INFIELD MIX, SEE FINISH SCHEDULE		
16 NEW PARKING LOT, SEE CIVIL PLANS		
17 NEW WATER QUALITY BASIN, SEE CIVIL PLANS		
18 NEW BENCH, TYP. (ON CONCRETE PAD PER CIVIL PLANS)	Q / L-9	5
19 NEW PICNIC TABLE - 2 ACCESSIBLE / 1 STANDARD; POUR THICKENED CONCRETE AT TABLES TO RECEIVE ANCHOR BOLTS TYP.	R / L-9	0
20 NEW BIKE RACK, TYP.	P / L-9	0
21 NEW ASSISTIVE LISTENING SIGNAGE (ON FENCE WHERE SHOWN) SEE FINISH SCHEDULE	-	2

- CONSTRUCTION NOTES:**
- ALL SYMBOLS ARE TYPICAL.
 - FOR CONSTRUCTION DETAILS SEE SHTS. L-6 THRU L-9.
 - FOR FINISH SCHEDULE, SEE SHT. L-6.
 - FOR ALL HORIZONTAL AND VERTICAL CONTROL SEE CIVIL PLANS.
 - FOR DRAINAGE PLAN, SEE CIVIL SHTS.
 - NEW PRACTICE BACKSTOPS TO MATCH EXISTING BACKSTOPS.

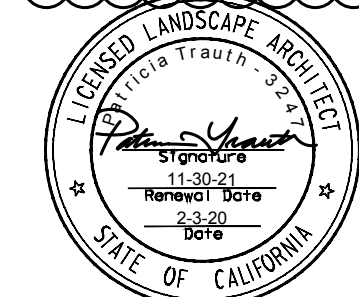

**WANGENHEIM NEIGHBORHOOD
JOINT USE FACILITY**
LANDSCAPE CONSTRUCTION PLANS

SPEC. NO.	CITY OF SAN DIEGO, CALIFORNIA PUBLIC WORKS DEPARTMENT SHEET 50 OF 142 SHEETS	WBS S-15007
APPROVED: FOR CITY ENGINEER JASON GRANI PRINT NAME	DATE 10/13/2020 77208	SUBMITTED BY: YOVANNA LEWIS PROJECT MANAGER
DESCRIPTION	BY	APPROVED
ORIGINAL	REC	
ADDENDUM B	REC	1/11/2021
1910-6291 (NAD83) CCS83 COORDINATE		
CONTRACTOR	DATE STARTED	40846-50-D
INSPECTOR	DATE COMPLETED	

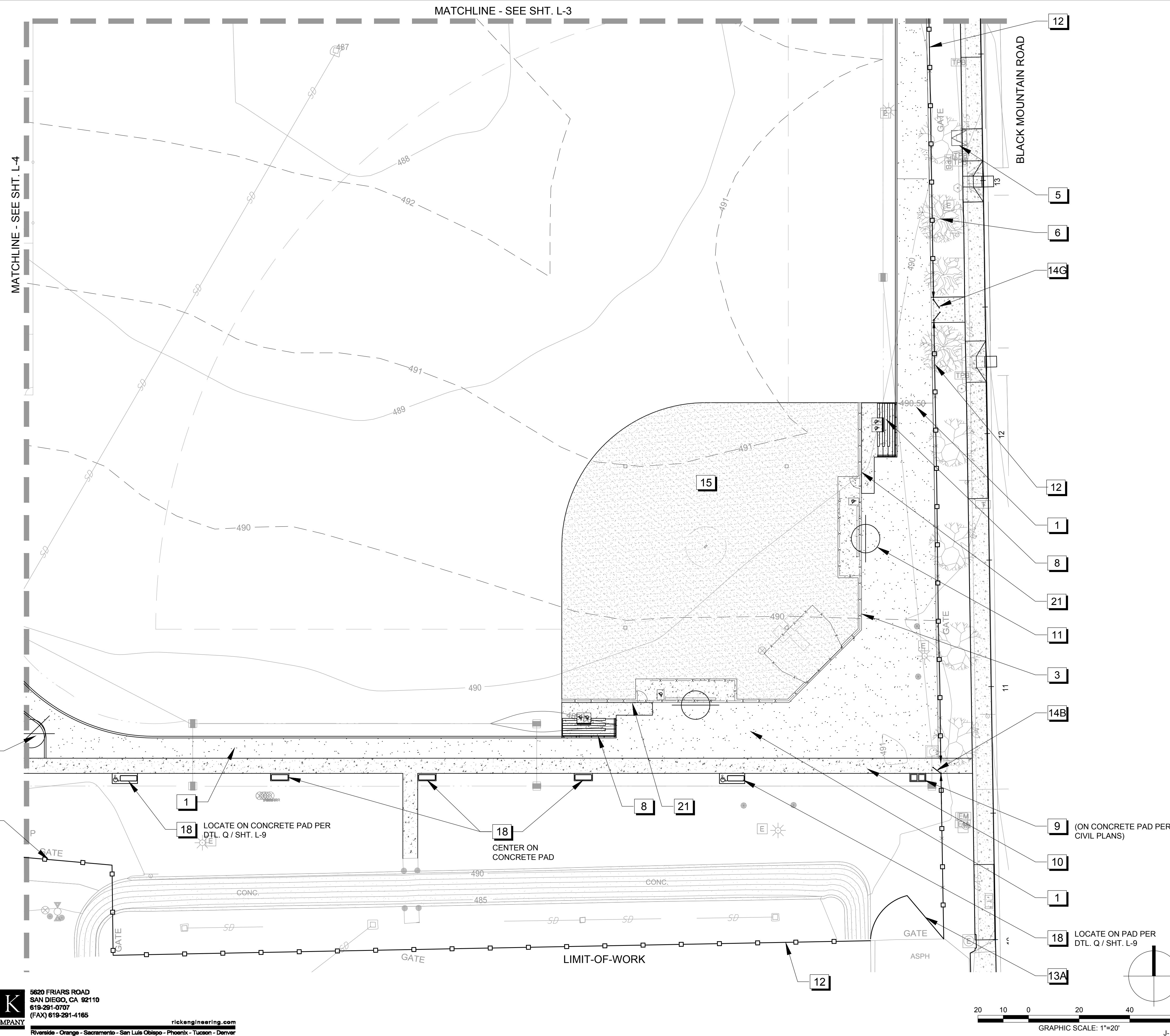

100%_DSD_2-4-2020

RICK
 ENGINEERING COMPANY
 5620 FRIARS ROAD
 SAN DIEGO, CA 92110
 619-291-0707
 (FAX) 619-291-4165
 rickengineering.com
 Riverside - Orange - Sacramento - San Luis Obispo - Phoenix - Tucson - Denver

IDENTIFICATION STAMP
 DIV. OF THE STATE ARCHITECT
 APP. 04-118244 INC.
 REVIEWED FOR
 SS FLS ACS
 DATE: 02.14.2020

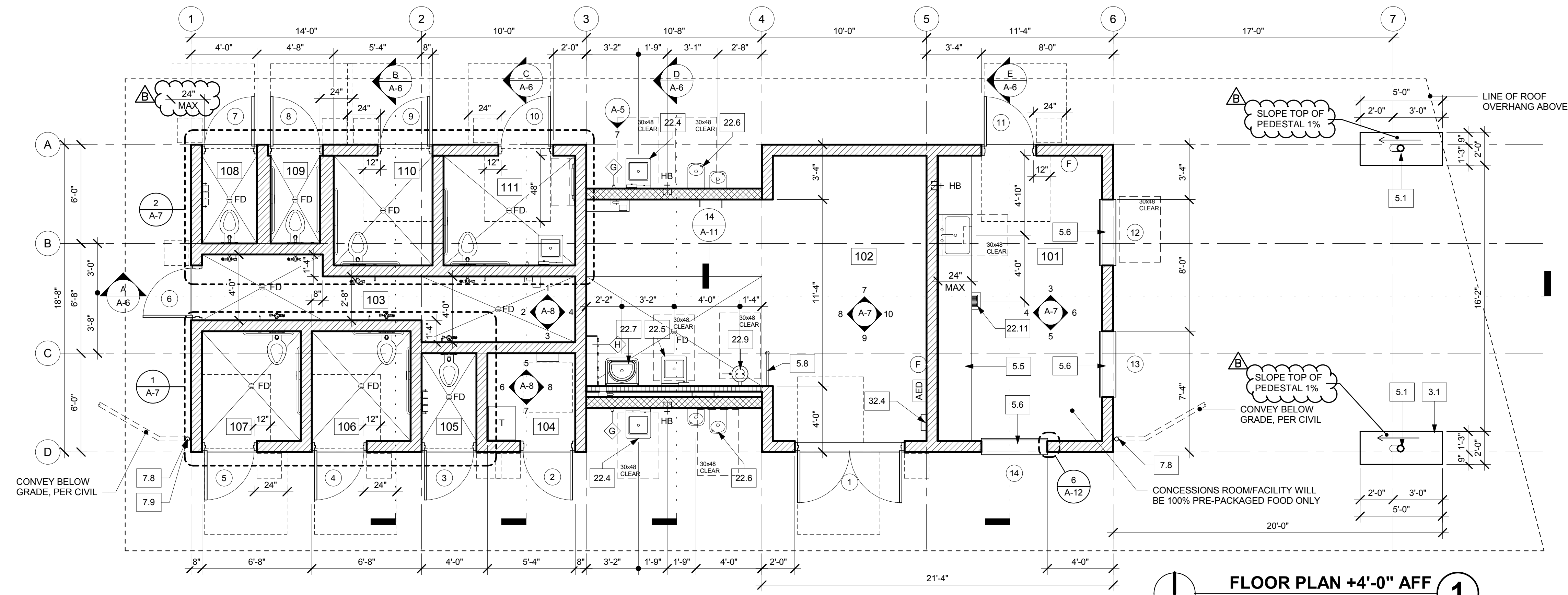

FLOOR PLAN +4'-0" AFF
 1/4" = 1'-0" **1**

KEYNOTES

- 3.1 CAST-IN-PLACE CONC PEDESTAL, PER STRUCTURAL AND SECTION 03 30 00
- 5.1 HSS COLUMN, PER STRUCTURAL AND SECTION 05 12 00
- 5.3 STEEL ANGLE GRATING FRAME, PER SECTION 05 50 00. REFER TO SHEET A-5 FOR REFERENCES TO SUBSTRATE ATTACHMENT
- 5.4 GALV STEEL GRATING WITH 1/8"x1/8" WIRE MESH, PER SECTION 05 53 13
- 5.5 SST COUNTERTOP
- 5.6 SST PASS-THROUGH COUNTER
- 5.8 CANE DETECTION RAILING, 1-1/2" DIA SST TUBE WITH PRE-DRILLED FLANGES AND ESCUTCHEONS SIMILAR TO GRAB BARS
- 6.1 GLUE-LAMINATED BEAM, ARCHITECTURAL GRADE, PER STRUCTURAL AND SECTION 06 18 00
- 7.8 3" DIA. GALV STEEL PIPE DOWNSPOUT, PER SECTION 07 62 00
- 7.9 GALV STEEL STRAP, PER SECTION 07 62 00
- 22.4 ACCESSIBLE LAVATORY, PER PLUMBING
- 22.5 LAVATORY, PER PLUMBING
- 22.6 ACCESSIBLE DRINKING FOUNTAIN WITH WATER BOTTLE FILLING STATION, PER PLUMBING
- 22.7 SERVICE SINK, PER PLUMBING
- 22.9 EYEWASH STATION, PER PLUMBING
- 22.11 FLOOR SINK, PER PLUMBING
- 32.4 IRRIGATION CONTROLLER, PER LANDSCAPE

LEGEND

- 8"x8"x16" RUNNING BOND CMU
- 10"x8"x16" RUNNING BOND CMU
- 8"x8"x16" STACKED BOND CMU
- 4"x8"x16" RUNNING BOND CMU
- FIRE EXTINGUISHER CLASS 4A:20B:C
- DOOR TAG, REFER TO DOOR SCHEDULE, SHEET A-9
- GRATING PANEL TAG, REFER TO A-5
- RESTROOM EQUIPMENT ID. REFER TO RESTROOM EQUIPMENT SCHEDULE, SHEET A-9
- FLOOR DRAIN, PER PLUMBING
- 18"x18" CLEAR AT SIGN

ROOM LEGEND

- 101 CONCESSION ROOM
- 102 STORAGE ROOM
- 103 PLUMBING CHASE
- 104 ELECTRICAL ROOM
- 105 TYPICAL ALL-GENDER RESTROOM
- 106 ACCESSIBLE ALL-GENDER RESTROOM
- 107 ACCESSIBLE ALL-GENDER RESTROOM
- 108 TYPICAL ALL-GENDER RESTROOM
- 109 AMBULATORY ACCESSIBLE ALL-GENDER RESTROOM
- 110 ACCESSIBLE ALL-GENDER RESTROOM
- 111 FAMILY RESTROOM

A-2

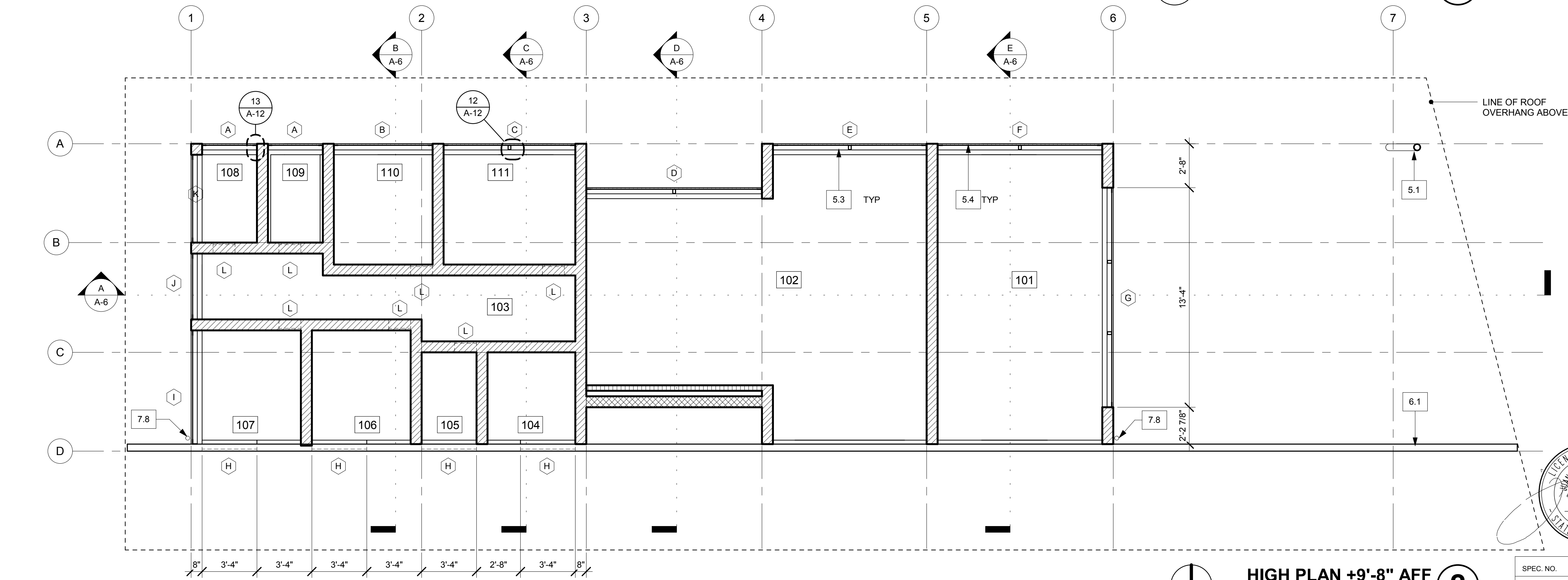

HIGH PLAN +9'-8" AFF
 1/4" = 1'-0" **2**

GENERAL PLAN NOTES:

1. ALL DIMENSIONS FOR ACCESS COMPLIANCE ARE TO FACE OF FINISH UNLESS OTHERWISE NOTED.
2. AREAS WITH FLOOR DRAINS AND SINKS SHALL HAVE SLOPES NOT STEEPER THAN 1:48 IN ALL DIRECTIONS.
3. FLOOR SINKS OR DRAINS OR TROUGHS EXPOSED TO P.O.T. OR TO PEDESTRIAN CIRCULATION PATHS SHALL HAVE 1/2" MAX. GRATE OPENINGS IN ALL DIRECTIONS. (CBC Sec. 11B-302.3)
4. OPERABLE PARTS OF ALL THE ACCESSIBLE ELEMENTS SHALL BE OPERABLE WITH ONE HAND AND SHALL NOT REQUIRE TIGHT GRASPING, PINCHING, OR TWISTING OF THE WRIST. THE FORCE REQUIRED TO ACTIVATE OPERABLE PARTS SHALL BE 5 POUNDS MAX. (CBC Sec. 11B-205 and 11B-309.4)

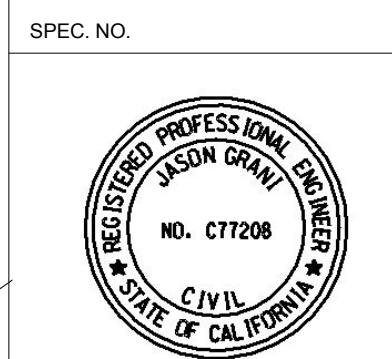
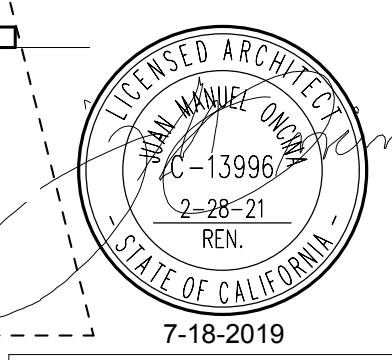

MANUEL ONCINA ARCHITECTS INC.
 ARCHITECTURE PLANNING INTERIORS
 5711 La Jolla Blvd
 La Jolla, CA 92037
 tel 858/459.1221
 fax 858/459.1214
 www.oncinaarc.com

WANGENHEIM NEIGHBORHOOD JOINT USE FACILITY ARCHITECTURAL FLOOR PLANS

CITY OF SAN DIEGO, CALIFORNIA PUBLIC WORKS DEPARTMENT SHEET 75 OF 142 SHEETS		WBS S-15007
APPROVED: JASON GRANI FOR CITY ENGINEER	DATE: 10/13/2020 77208	SUBMITTED BY: YOVANNA LEWIS PROJECT MANAGER
PRINT NAME: JASON GRANI	RCE#: 77208	CHECKED BY: MEHDI RASHIDPOUR-HARISI PROJECT ENGINEER
DESCRIPTION	BY	APPROVED
ORIGINAL	REC	
ADDENDUM B	REC	1/11/2021
DATE STARTED		DATE COMPLETED
CONTRACTOR INSPECTOR		40846-75-D

IDENTIFICATION STAMP
 DIV. OF THE STATE ARCHITECT
 APP. 04-118244 INC.
 REVIEWED FOR
 SS FLS ACS
 DATE: 02.14.2020

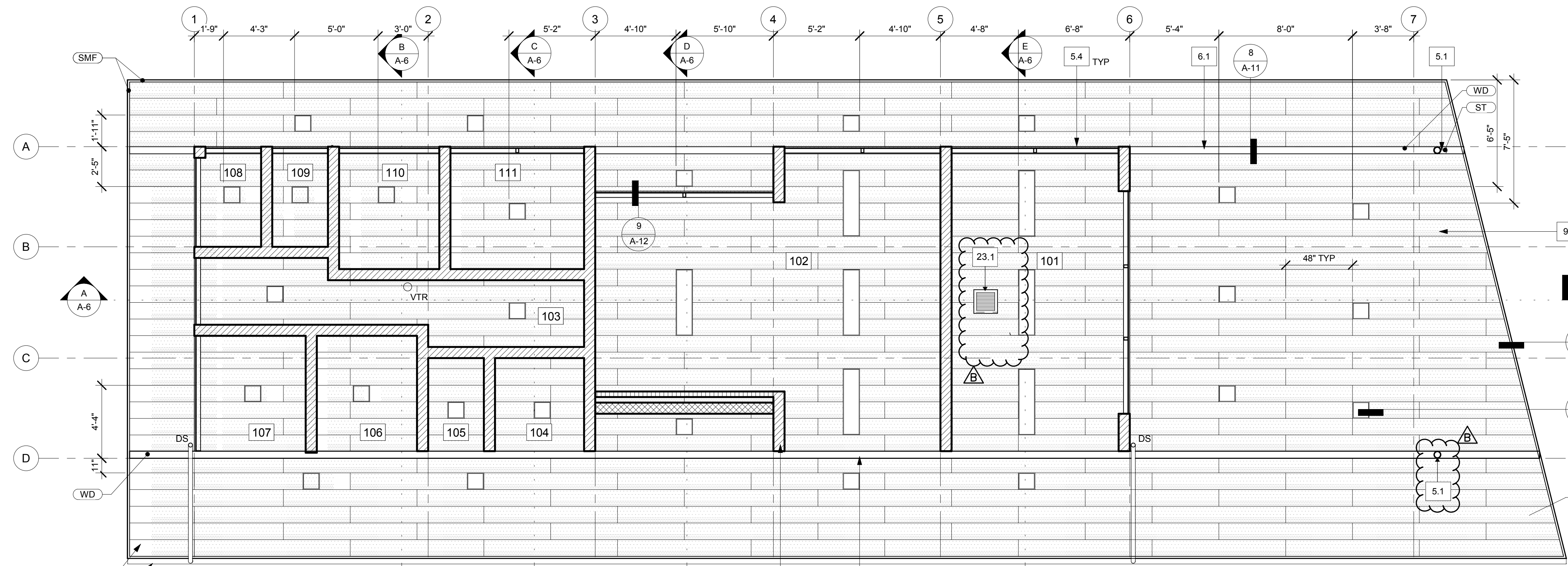

REFLECTED CEILING PLAN 1
 1/4" = 1'-0"

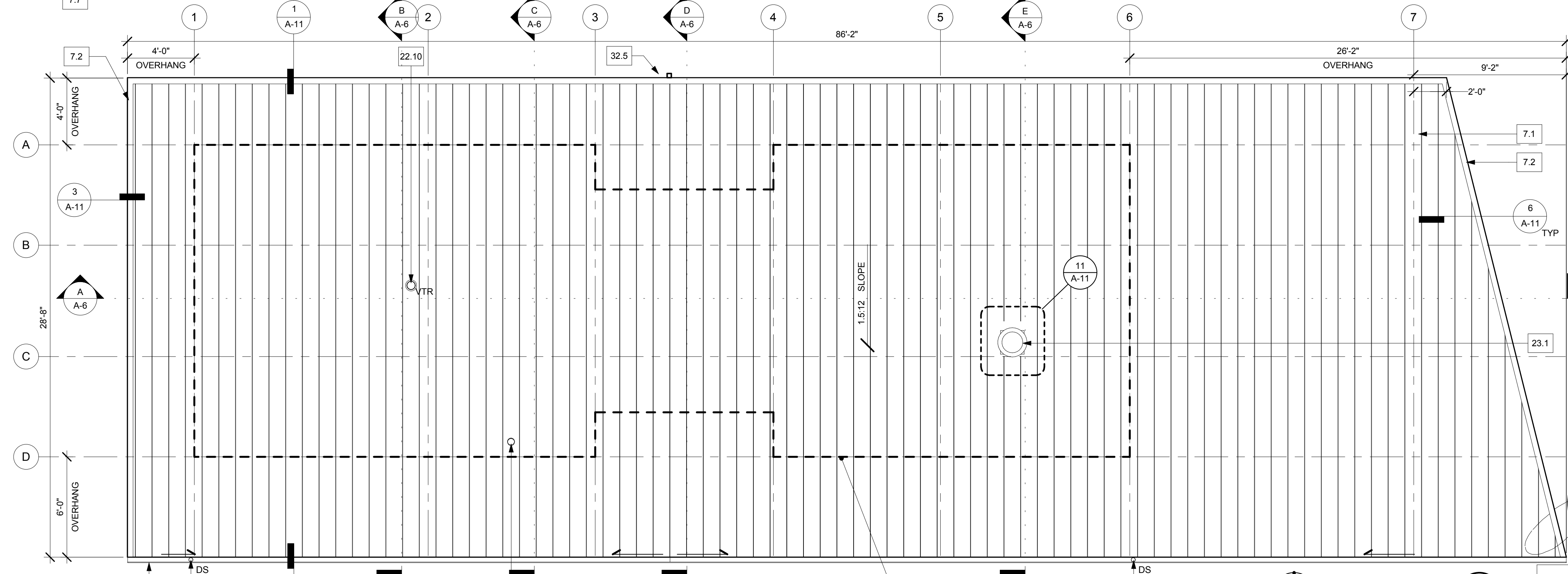

ROOF PLAN 2
 1/4" = 1'-0"

- KEYNOTES**
- 4.1 CMU WALL, PER STRUCTURAL AND SECTION 04 22 00, TYPE AND PATTERN PER LEGEND
 - 5.1 HSS COLUMN, PER STRUCTURAL AND SECTION 05 12 00
 - 5.4 GALV STEEL GRATING WITH 1/8"x1/8" WIRE MESH, PER SECTION 05 53 13
 - 6.1 GLUE-LAMINATED BEAM, ARCHITECTURAL GRADE, PER STRUCTURAL AND SECTION 06 18 00
 - 7.1 VERTICAL SEAM METAL ROOF SYSTEM, 24 GA PANEL, FASTEN CONCEALED CLIPS TO PLYWOOD PER STRUCTURAL AT 24" O.C. WITH #10-12 X 1" LONG PANCAKE HEAD SCREWS BASED ON 24 GA PANELS AND 75 PSF MAX WIND UPLIFT IN ACCORDANCE WITH ICC ESR-2385 AND DETAIL 6/A-11
 - 7.2 SHEET METAL FLASHING, PER SECTION 07 62 00
 - 7.7 SHEET METAL GUTTER, PER SECTION 07 62 00, AND DETAIL 2/A-11
 - 7.8 3" DIA. GALV STEEL PIPE DOWNSPOUT, PER SECTION 07 62 00
 - 9.1 FIBER CEMENT PANEL, VENTED, PER SECTION 07 46 46, FASTEN DIRECTLY TO JOIST, BEAM OR SOLID BLOCKING WITH SST PANCAKE HEAD #10-13 X 1-1/2" GP WOOD SCREWS AT 16" O.C. MAX
 - 22.10 SST VENT THROUGH ROOF, MILL FINISH, PAINT TO MATCH ROOF, WITH SST VANDAL PROOF CAP
 - 23.1 EXHAUST FAN, PER MECHANICAL FLOOR PLAN, SHEET M-2
 - 26.3 PHOTO CELL, MOUNT ON ROOF, PER E-12, PENETRATION PER DETAIL 4/A-11
 - 32.5 RAIN GAUGE, PER LANDSCAPE

- LEGEND**
- RUNNING BOND CMU
 - STACKED BOND CMU
 - 4" RUNNING BOND CMU
 - VENT THROUGH ROOF, PER 4/A-11
 - 12x12 LIGHT, RECESSED, PER E-12 AND 9/A-11
 - 12x48 LIGHT, RECESSED, PER E-12 AND 9/A-11
 - DOWNSPOUT

- ROOM LEGEND**
- 101 CONCESSION ROOM
 - 102 STORAGE ROOM
 - 103 PLUMBING CHASE
 - 104 ELECTRICAL ROOM
 - 105 TYPICAL ALL-GENDER RESTROOM
 - 106 ACCESSIBLE ALL-GENDER RESTROOM
 - 107 ACCESSIBLE ALL-GENDER RESTROOM
 - 108 TYPICAL ALL-GENDER RESTROOM
 - 109 AMBULATORY ACCESSIBLE ALL-GENDER RESTROOM
 - 110 ACCESSIBLE ALL-GENDER RESTROOM
 - 111 FAMILY RESTROOM

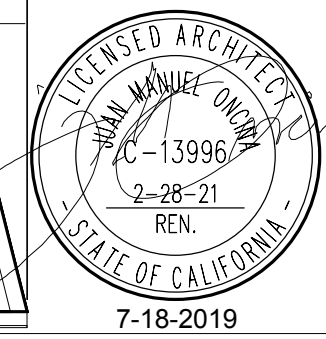

WANGENHEIM NEIGHBORHOOD JOINT USE FACILITY
ARCHITECTURAL RCP AND ROOF PLANS

CITY OF SAN DIEGO, CALIFORNIA
 PUBLIC WORKS DEPARTMENT
 SHEET 76 OF 142 SHEETS

APPROVED:	DATE: 10/13/2020	PROJECT MANAGER: YOVANNA LEWIS			
FOR CITY ENGINEER: JASON GRANI	DATE: 7/20/20	PROJECT ENGINEER: MEHDI RASHIDPOUR-HARISI			
PRINT NAME: JASON GRANI	RCE#: 77208	PROJECT ENGINEER: MEHDI RASHIDPOUR-HARISI			
DESCRIPTION	BY	APPROVED	DATE	FILMED	
ORIGINAL	REC				270-1731 (NAD27)
ADDENDUM B	REC		1/11/2021		CCS27 COORDINATE
					1910-6291 (NAD83)
					CCS83 COORDINATE

CONTRACTOR INSPECTOR
 DATE STARTED
 DATE COMPLETED

A-3

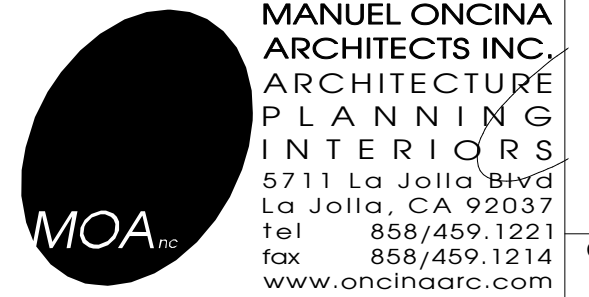

IDENTIFICATION STAMP
 DIV. OF THE STATE ARCHITECT
 APP. 04-118244 INC.
 REVIEWED FOR
 SS FLS ACS
 DATE: 02.14.2020

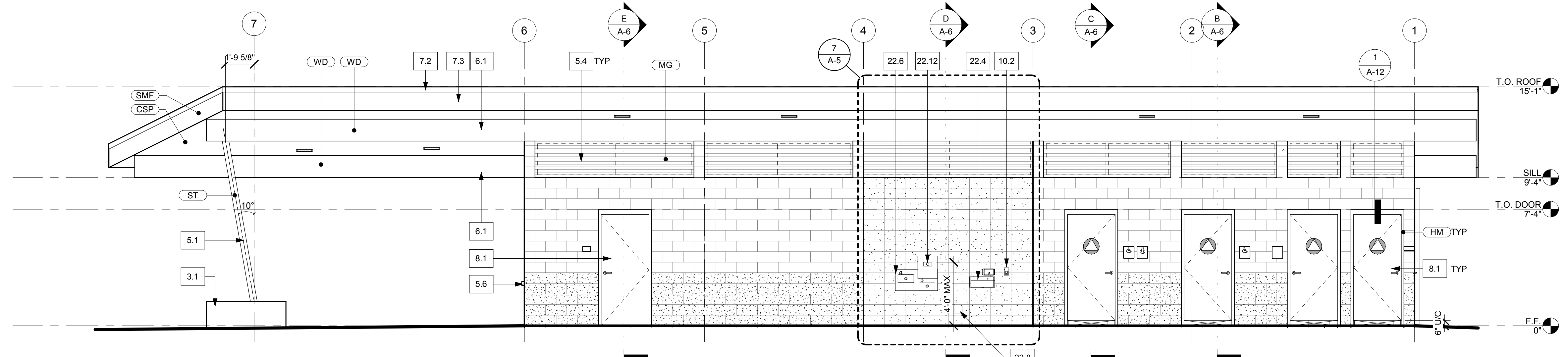

NORTH ELEVATION
 1/4" = 1'-0" **1**

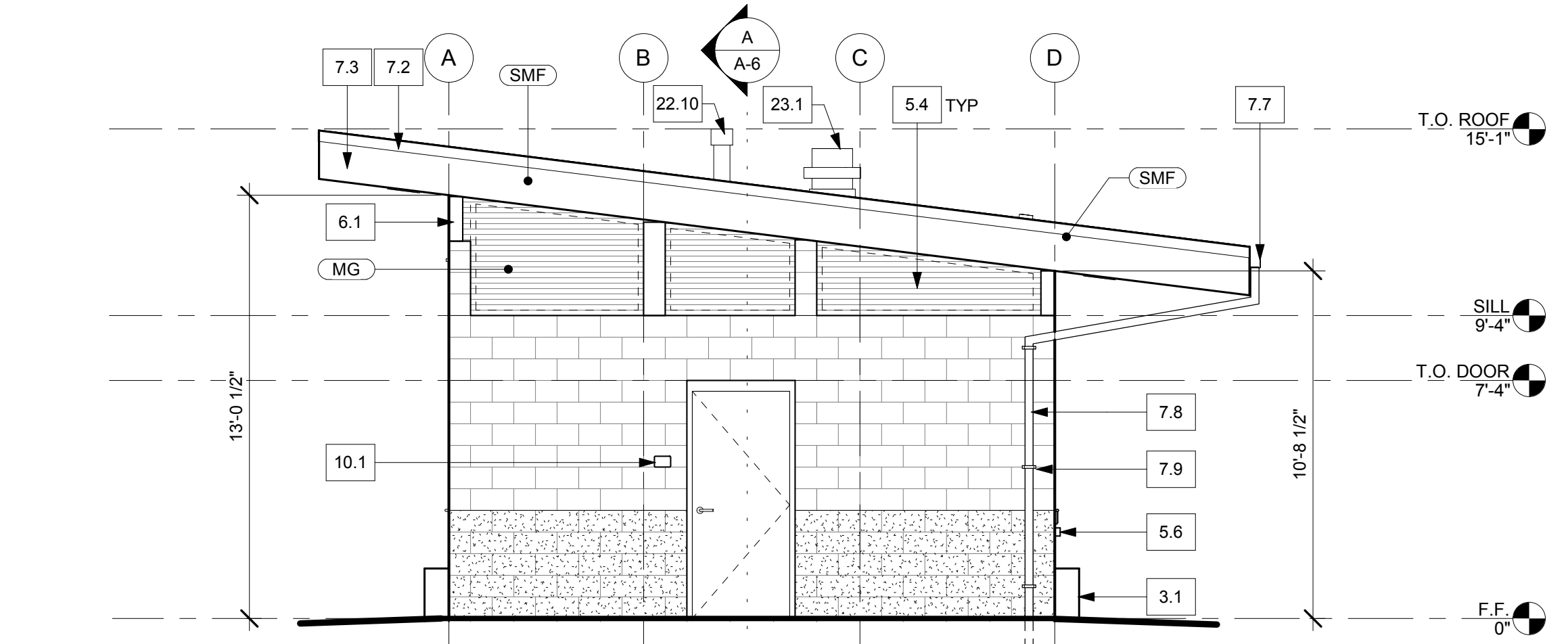

WEST ELEVATION
 1/4" = 1'-0" **3**

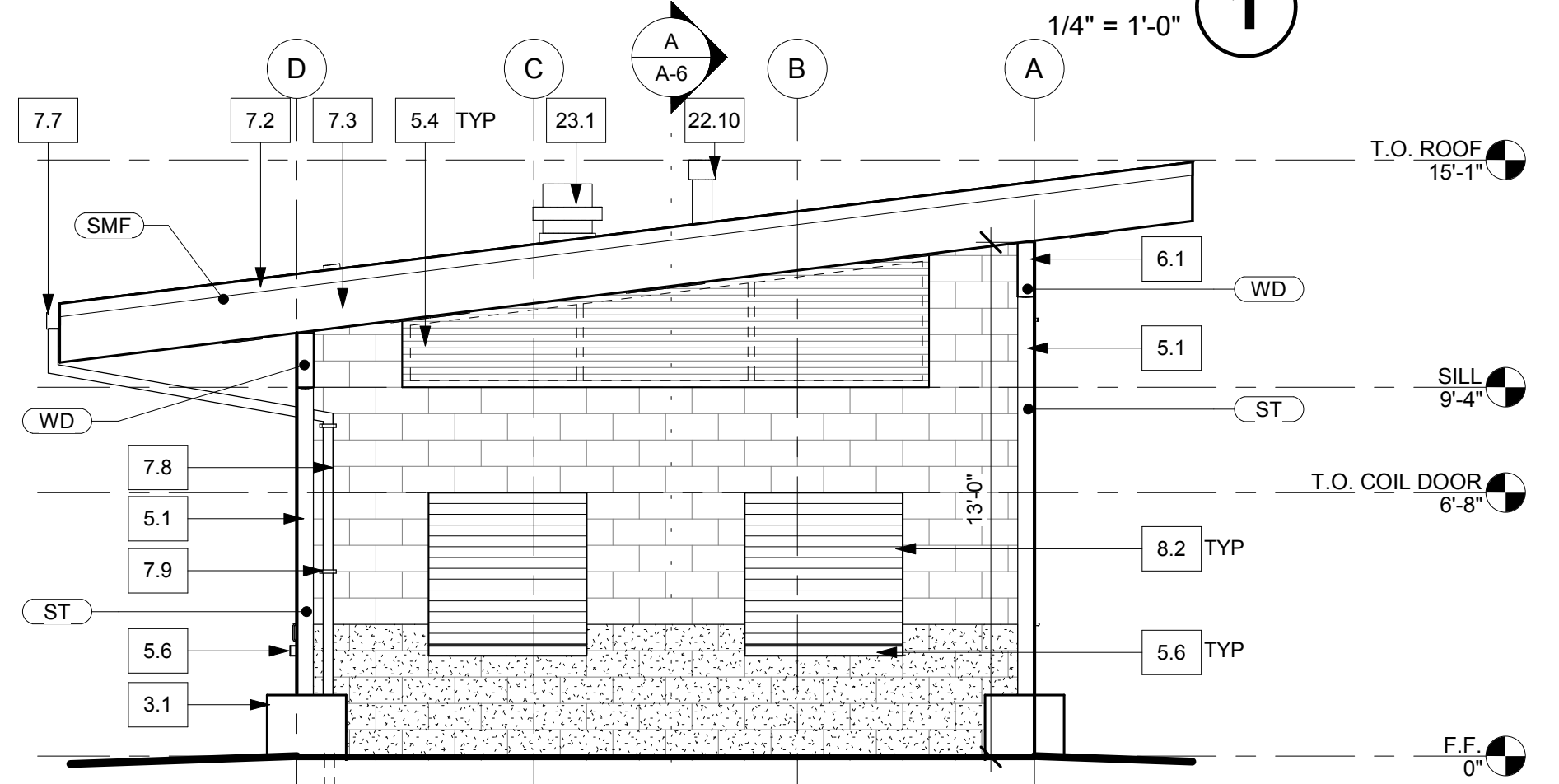

EAST ELEVATION
 1/4" = 1'-0" **2**

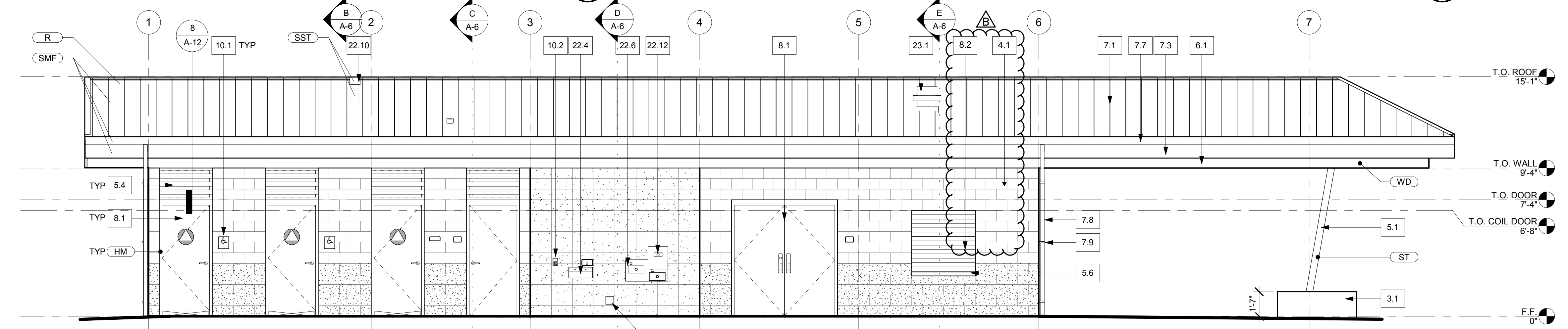

SOUTH ELEVATION
 1/4" = 1'-0" **4**

KEYNOTES

- 3.1 CAST-IN-PLACE CONC PEDESTAL, PER STRUCTURAL AND SECTION 03 30 00
- 4.1 CMU WALL, PER STRUCTURAL AND SECTION 04 22 00, TYPE AND PATTERN PER LEGEND
- 5.1 HSS COLUMN, PER STRUCTURAL AND SECTION 05 12 00
- 5.4 GALV STEEL GRATING WITH 1/8"x1/8" WIRE MESH, PER SECTION 05 53 13
- 5.6 SST PASS-THROUGH COUNTER
- 6.1 GLUE-LAMINATED BEAM, ARCHITECTURAL GRADE, PER STRUCTURAL AND SECTION 06 18 00
- 7.1 METAL SALES VERTICAL SEAM METAL ROOF SYSTEM, INSTALL WITH ATLAS #10-12 x 1" LONG PANCAKE HEAD WOOD SCREWS PER ICC-ESR-2385 OVER ONE LAYER VERSASHIELD FIRE-RESISTANT ROOF DECK PROTECTION, CLASS 'A', LAP SEALANT REQUIRED, PER SCHEDULE AND SECTION 07 41 13.16
- 7.2 SHEET METAL FLASHING, PER SECTION 07 62 00
- 7.3 PRE-FINISHED METAL FASCIA TO MATCH ROOF, 07 62 00
- 7.7 SHEET METAL GUTTER, PER SECTION 07 62 00, AND DETAIL 2/A-11
- 7.8 3" DIA. GALV STEEL PIPE DOWNSPOUT, PER SECTION 07 62 00
- 7.9 GALV STEEL STRAP, PER SECTION 07 62 00
- 8.1 DOOR, PER SCHED AND SECTION 08 11 13
- 8.2 OVERHEAD COILING DOOR, PER SCHED AND SECTION 08 33 13
- 10.1 TACTILE SIGN, PER SCHED AND SECTION 10 14 23.13
- 10.2 THROUGH-WALL CHASE-MOUNT HAND DRYER, 4" MAX PROJECTION ALLOWED FROM FACE OF WALL
- 22.4 ACCESSIBLE LAVATORY, PER PLUMBING
- 22.6 ACCESSIBLE DRINKING FOUNTAIN WITH WATER BOTTLE FILLING STATION, PER PLUMBING
- 22.8 HOSE BOX, RECESSED, LOCKING DOOR, PER PLUMBING
- 22.10 SST VENT THROUGH ROOF, MILL FINISH, PAINT TO MATCH ROOF, WITH SST VANDAL PROOF CAP
- 22.12 BOTTLE FILLER, PER PLUMBING
- 23.1 EXHAUST FAN, PER MECHANICAL FLOOR PLAN, SHEET M-2

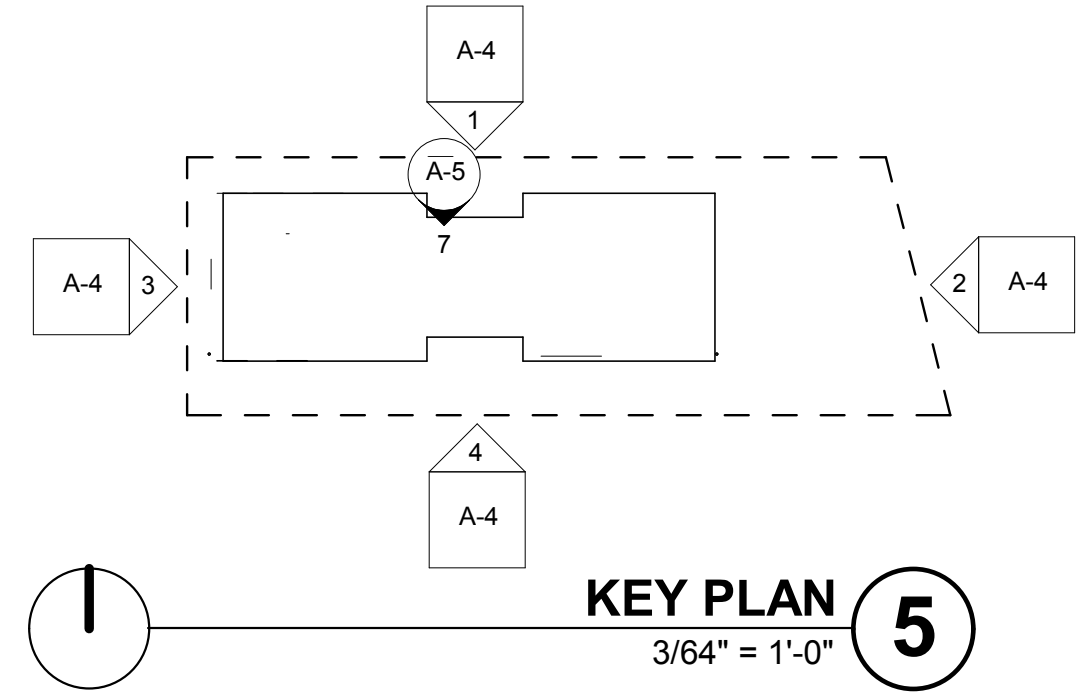

KEY PLAN
 3/64" = 1'-0" **5**

LEGEND

- RUNNING BOND CMU PATTERN
- STACKED BOND CMU PATTERN
- C1 PRECISION CMU, PER EXTERIOR FINISH SCHEDULE
- C2 PRECISION CMU, PER EXTERIOR FINISH SCHEDULE
- C3 PRECISION CMU, PER EXTERIOR FINISH SCHEDULE
- C4 BURNISHED CMU, STACKED BOND, PER EXTERIOR FINISH SCHEDULE
- GEOMETRIC SYMBOL, PER 11/A-10
- GALVANIZED STEEL GRATING WITH 1/8"x1/8" WIRE MESH, PER SECTION 05 53 00

SPEC. NO.		CITY OF SAN DIEGO, CALIFORNIA PUBLIC WORKS DEPARTMENT SHEET 77 OF 142 SHEETS		WBS	S-15007
APPROVED:	DATE	10/13/2020	DATE	10/13/2020	PROJECT MANAGER
FOR CITY ENGINEER	JASON GRANI	RCE#	77208		YOVANNA LEWIS
PRINT NAME					PROJECT ENGINEER
DESCRIPTION	BY	APPROVED	DATE	FILMED	MEHDI RASHIDPOUR-HARISI
ORIGINAL	REC				270-1731 (NAD27)
ADDENDUM B	REC		1/11/2021		CCS27 COORDINATE
					1910-6291 (NAD83)
					CCS83 COORDINATE
CONTRACTOR	INSPECTOR	DATE STARTED	DATE COMPLETED		40846-77-D

MANUEL ONCINA
 ARCHITECTS INC.
 ARCHITECTURE
 PLANNING
 INTERIORS
 5711 La Jolla Blvd
 La Jolla, CA 92037
 tel 858/459.1221
 fax 858/459.1214
 www.oncinaarc.com



IDENTIFICATION STAMP
 DIV. OF THE STATE ARCHITECT
 APP. 04-118244 INC.
 REVIEWED FOR
 SS FLS ACS
 DATE: 02.14.2020

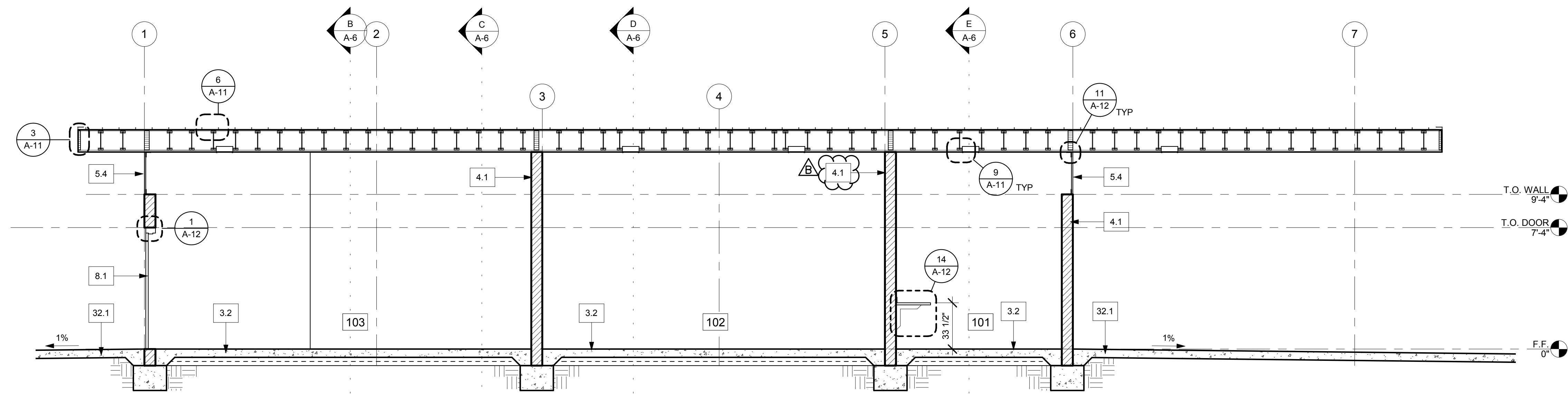

SECTION A
 1/4" = 1'-0" **(A)**

- KEYNOTES**
- 3.2 CONC SLAB, OVER VAPOR BARRIER AND SAND, PER STRUCTURAL AND SECTION 03 30 00
 - 4.1 CMU WALL, PER STRUCTURAL AND SECTION 04 22 00, TYPE AND PATTERN PER LEGEND
 - 5.4 GALV STEEL GRATING WITH 1/8"x1/8" WIRE MESH, PER SECTION 05 53 13
 - 6.1 GLUE-LAMINATED BEAM, ARCHITECTURAL GRADE, PER STRUCTURAL AND SECTION 06 18 00
 - 8.1 DOOR, PER SCHED AND SECTION 08 11 13
 - 8.2 OVERHEAD COILING DOOR, PER SCHED AND SECTION 08 33 13
 - 26.1 RECESSED LIGHT FIXTURE, PER E-2, TYP
 - 32.1 CONC FLATWORK PER CIVIL, SLOPE 1% AWAY FROM BUILDING

- LEGEND**
- RUNNING BOND CMU
 - STACKED BOND CMU
 - 4" RUNNING BOND CMU
 - VENT THROUGH ROOF, PER 4/A-11
 - 12x12 LIGHT, RECESSED, PER E-12
 - 12x48 LIGHT, RECESSED, PER E-12
 - DOWNSPOUT

- ROOM LEGEND**
- 101 CONCESSION ROOM
 - 102 STORAGE ROOM
 - 103 PLUMBING CHASE
 - 104 ELECTRICAL ROOM
 - 105 TYPICAL ALL-GENDER RESTROOM
 - 106 ACCESSIBLE ALL-GENDER RESTROOM
 - 107 ACCESSIBLE ALL-GENDER RESTROOM
 - 108 TYPICAL ALL-GENDER RESTROOM
 - 109 AMBULATORY ACCESSIBLE ALL-GENDER RESTROOM
 - 110 ACCESSIBLE ALL-GENDER RESTROOM
 - 111 FAMILY RESTROOM

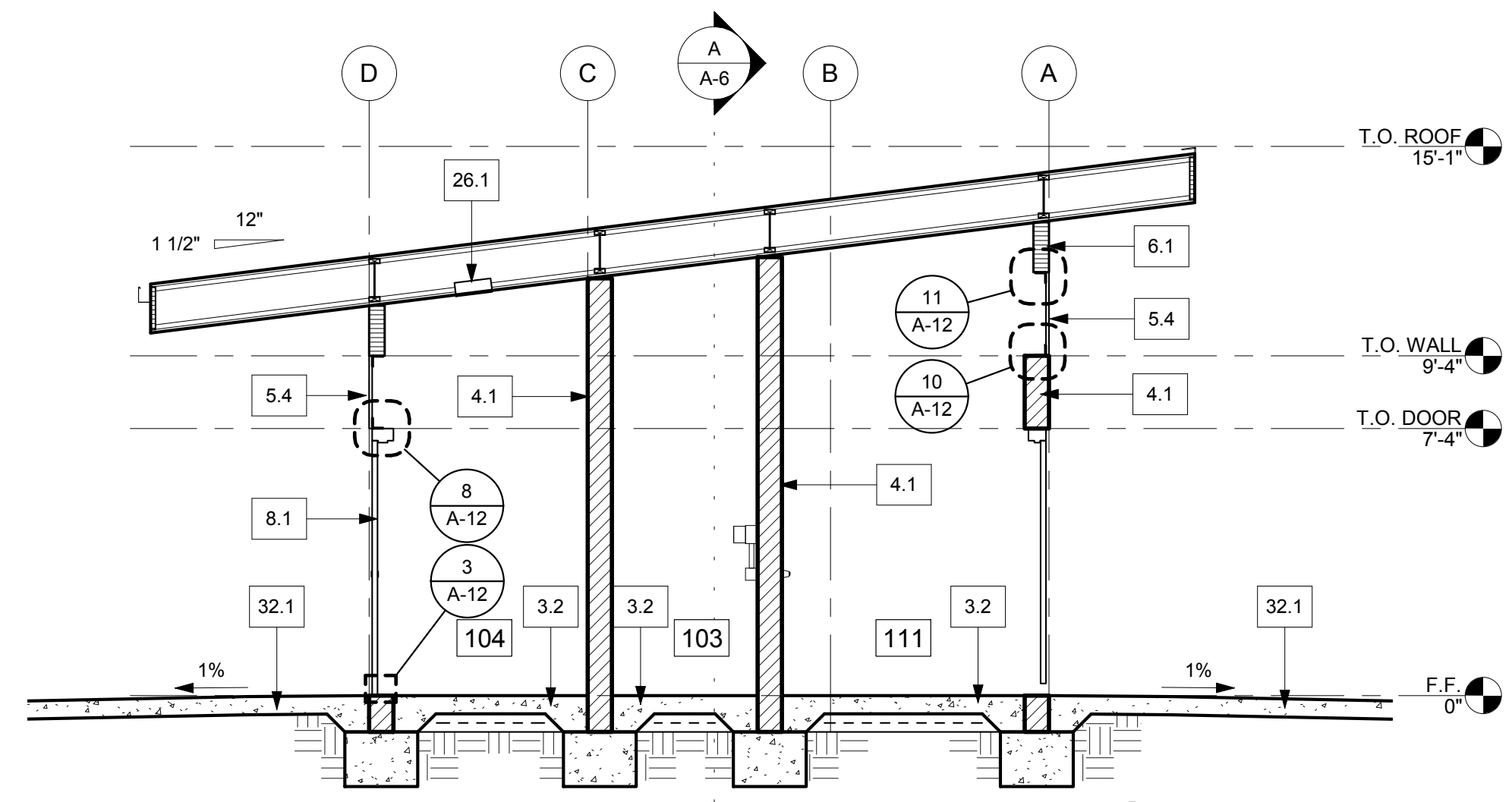

SECTION C
 1/4" = 1'-0" **(C)**

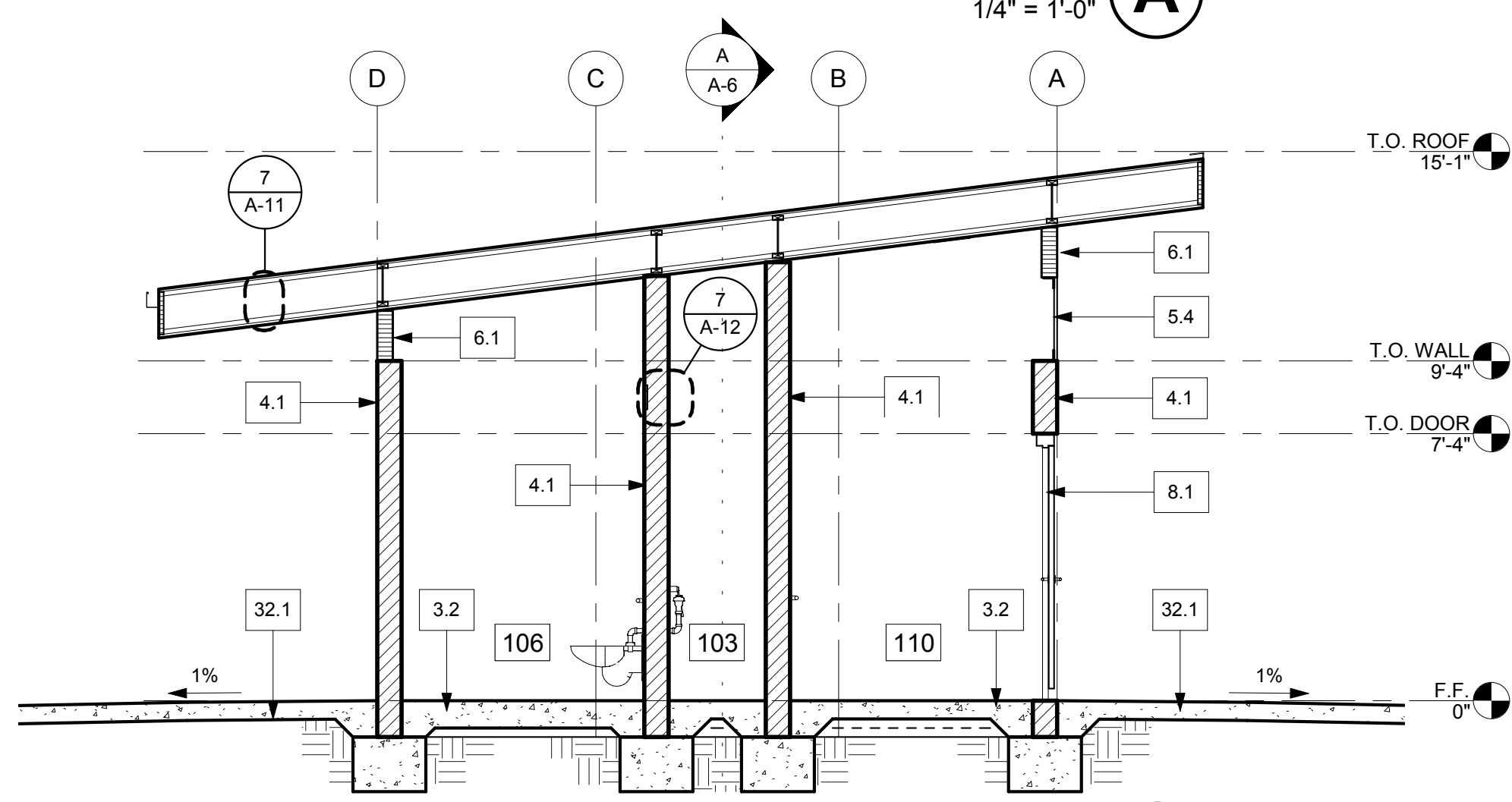

SECTION B
 1/4" = 1'-0" **(B)**

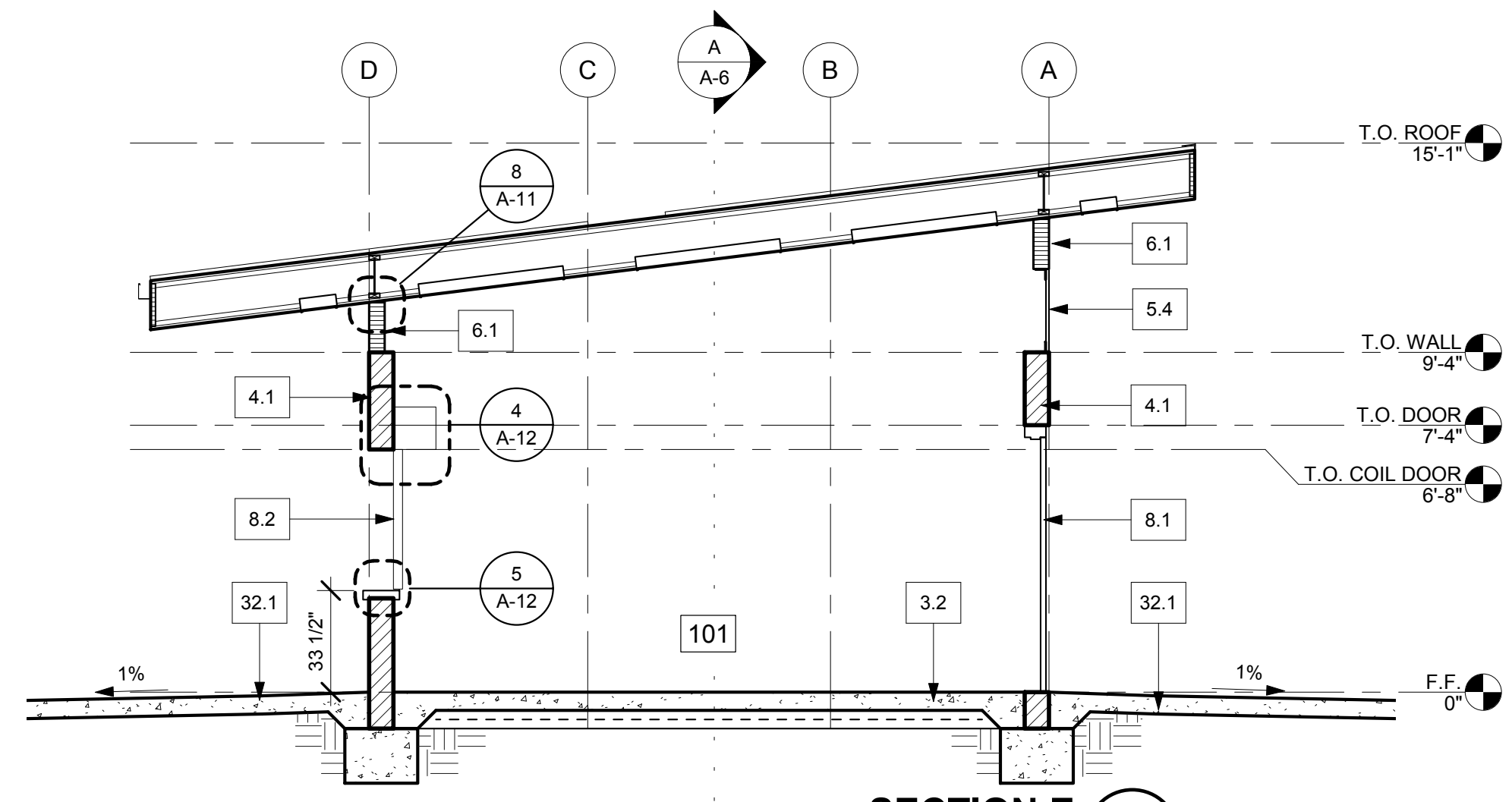

SECTION E
 1/4" = 1'-0" **(E)**

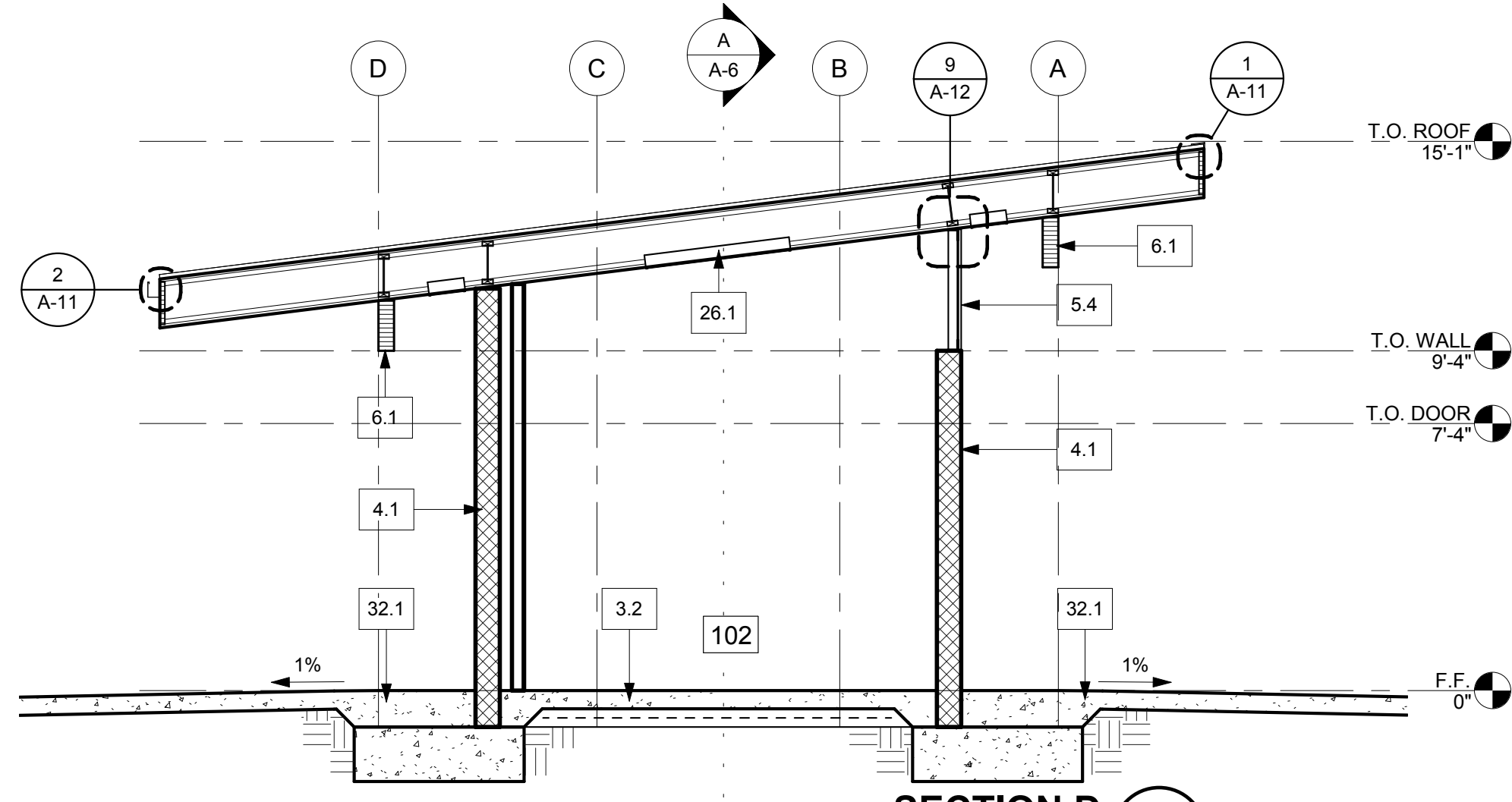

SECTION D
 1/4" = 1'-0" **(D)**

A-6

**WANGENHEIM NEIGHBORHOOD
 JOINT USE FACILITY**

ARCHITECTURAL SECTIONS

SPEC. NO.		CITY OF SAN DIEGO, CALIFORNIA PUBLIC WORKS DEPARTMENT SHEET 79 OF 142 SHEETS		WBS	S-15007
APPROVED:	10/13/2020	DATE		SUBMITTED BY:	YOVANNA LEWIS
FOR CITY ENGINEER	JASON GRANI	DATE		PROJECT MANAGER	
PRINT NAME	RCE#	77208		CHECKED BY:	MEHDI RASHIDPOUR-HARISI
DESCRIPTION	BY	APPROVED	DATE	FILMED	PROJECT ENGINEER
ORIGINAL	REC				270-1731 (NAD27)
ADDENDUM B	REC		1/11/2021		CCS27 COORDINATE
					1910-6291 (NAD83)
					CCS83 COORDINATE
CONTRACTOR	INSPECTOR	DATE STARTED	DATE COMPLETED	40846-79-D	

**MANUEL ONCINA
 ARCHITECTS INC.**
 ARCHITECTURE
 PLANNING
 INTERIORS
 5711 La Jolla Blvd
 La Jolla, CA 92037
 tel 858/459.1221
 fax 858/459.1214
 www.oncinaarc.com



CALLOUT ADDED

IDENTIFICATION STAMP
 DIV. OF THE STATE ARCHITECT
 APP. 04-118244 INC.
 REVIEWED FOR
 SS FLS ACS
 DATE: 02.14.2020

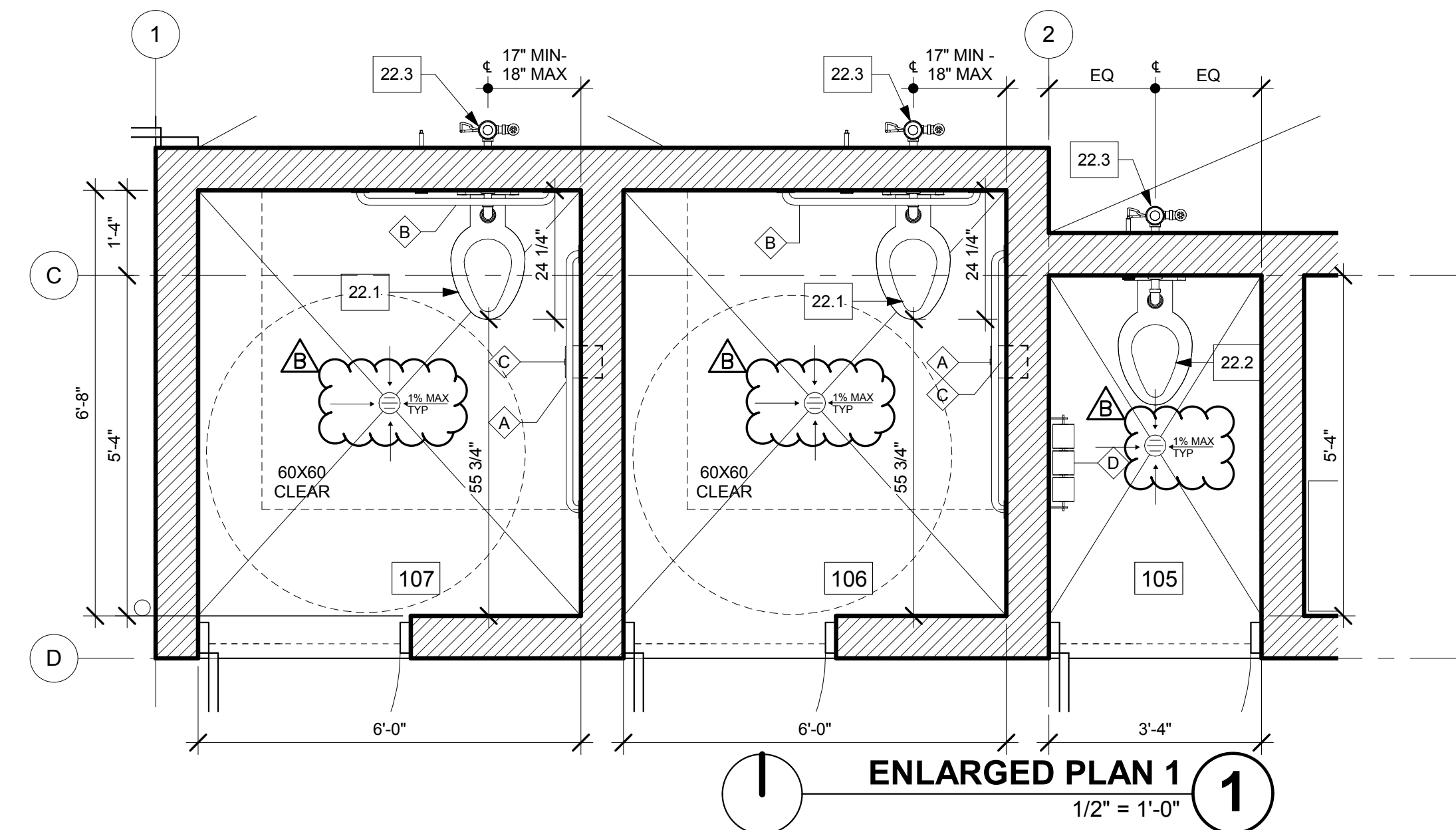
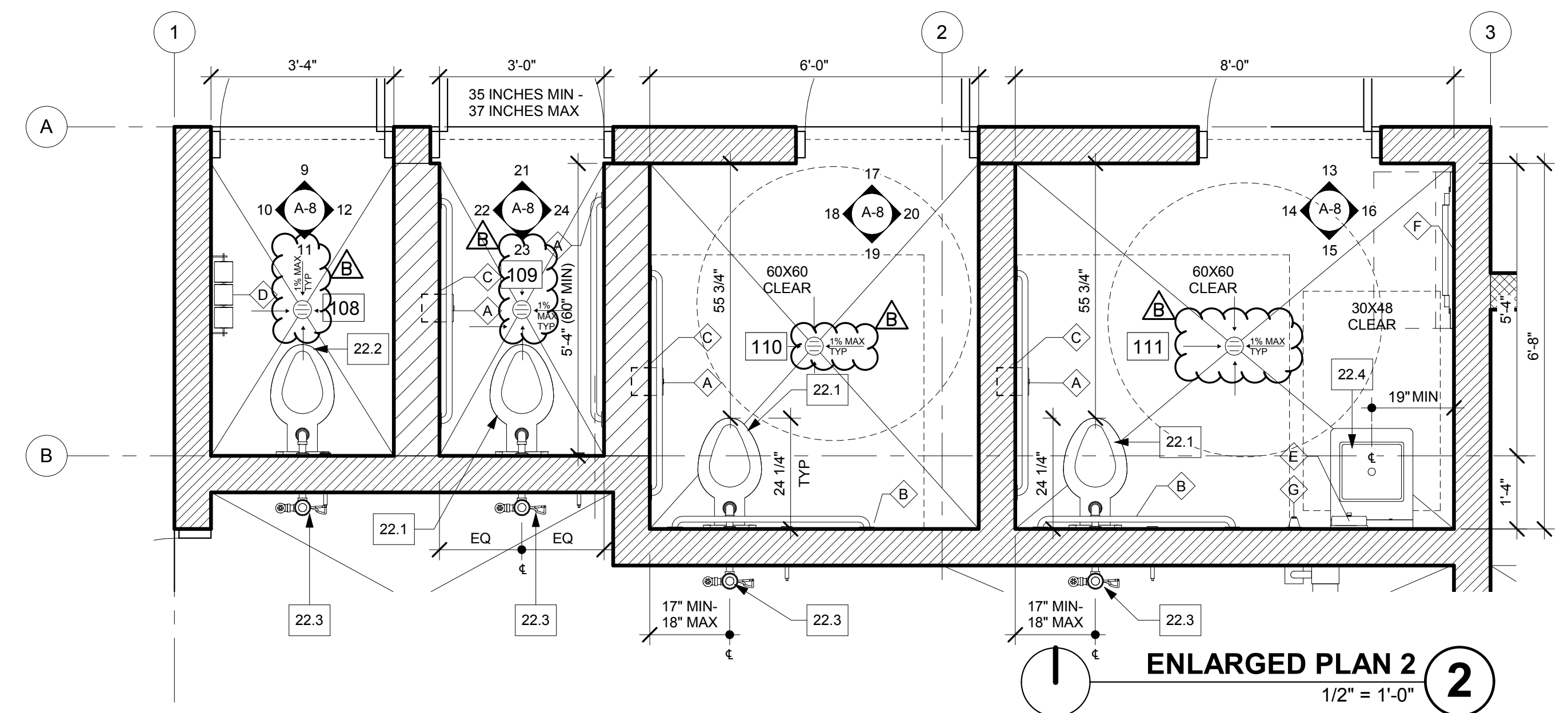

- KEYNOTES**
- 5.3 STEEL ANGLE GRATING FRAME, PER SECTION 05 50 00, REFER TO SHEET A-5 FOR REFERENCES TO SUBSTRATE ATTACHMENT
 - 5.4 GALV STEEL GRATING WITH 1/8"x1/8" WIRE MESH, PER SECTION 05 53 13
 - 5.5 SST COUNTERTOP
 - 5.6 SST PASS-THROUGH COUNTER
 - 5.8 CANE DETECTION RAILING, 1-1/2" DIA SST TUBE WITH PRE-DRILLED FLANGES AND ESCUTCHEONS SIMILAR TO GRAB BARS.
 - 6.1 GLUE-LAMINATED BEAM, ARCHITECTURAL GRADE, PER STRUCTURAL AND SECTION 08 18 00
 - 8.1 DOOR, PER SCHED AND SECTION 08 11 13
 - 8.2 OVERHEAD COILING DOOR, PER SCHED AND SECTION 08 33 13
 - 10.2 THROUGH-WALL CHASE-MOUNT HAND DRYER, 4" MAX PROJECTION ALLOWED FROM FACE OF WALL
 - 10.3 MOP AND RAG HOLDER WITH SHELF, PER RR ACCESSORIES SCHEDULE PROVIDE SS APRON TO FLOOR
 - 10.4 PORTABLE FIRE EXTINGUISHER, 2A:10BC MIN, PER SECTION 10 44 16
 - 22.1 ACCESSIBLE TOILET, PER PLUMBING
 - 22.2 TOILET, PER PLUMBING
 - 22.3 THROUGH-WALL FLUSHOMETER, PER PLUMBING
 - 22.4 ACCESSIBLE LAVATORY, PER PLUMBING
 - 22.5 LAVATORY, PER PLUMBING
 - 22.7 SERVICE SINK, PER PLUMBING
 - 22.9 EYEWASH STATION, PER PLUMBING
 - 22.10 8" x 8" x 32" LONG CONCRETE CURB FROM CORNER EXTENDING UNDER HAND DRYER MOTOR AND FILTER

- LEGEND**
- 8"x8"x16" RUNNING BOND CMU
 - 10"x8"x16" RUNNING BOND CMU
 - RUNNING BOND CMU
 - STACKED BOND CMU
 - C4 BURNISHED CMU, PER EXTERIOR FINISH SCHEDULE
 - RESTROOM EQUIPMENT ID, REFER TO RESTROOM EQUIPMENT SCHEDULE
 - SIGN, PER SCHEDULE

- GENERAL PLAN NOTES:**
1. ALL DIMENSIONS FOR ACCESS COMPLIANCE ARE TO FACE OF FINISH UNLESS OTHERWISE NOTED.
 2. AREAS WITH FLOOR DRAINS AND SINKS SHALL HAVE SLOPES NOT STEEPER THAN 1:48 IN ALL DIRECTIONS.
 3. FLOOR SINKS OR DRAINS OR TROUGHS EXPOSED TO P.O.T. OR TO PEDESTRIAN CIRCULATION PATHS SHALL HAVE 1/2" MAX. GRATE OPENINGS IN ALL DIRECTIONS. (CBC Sec. 11B-302.3)
 4. OPERABLE PARTS OF ALL THE ACCESSIBLE ELEMENTS SHALL BE OPERABLE WITH ONE HAND AND SHALL NOT REQUIRE TIGHT GRASPING, PINCHING, OR TWISTING OF THE WRIST. THE FORCE REQUIRED TO ACTIVATE OPERABLE PARTS SHALL BE 5 POUNDS MAX. (CBC Sec. 11B-205 and 11B-309.4)

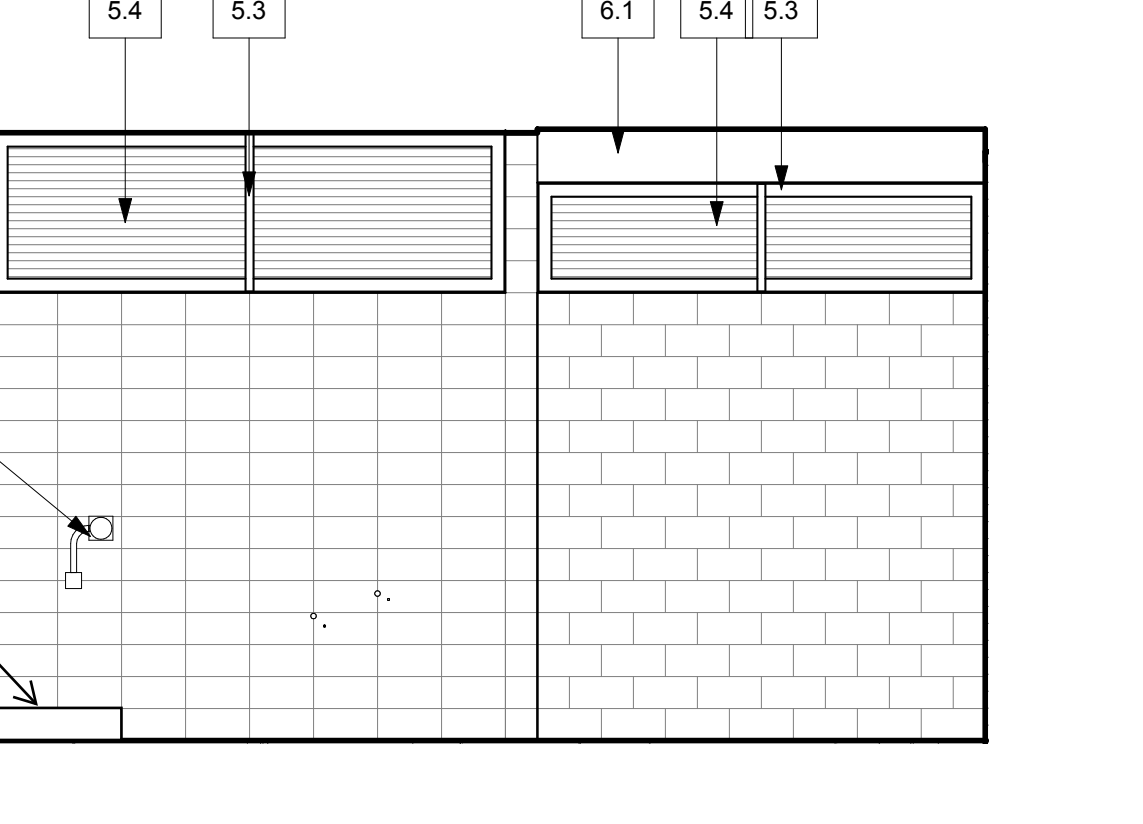
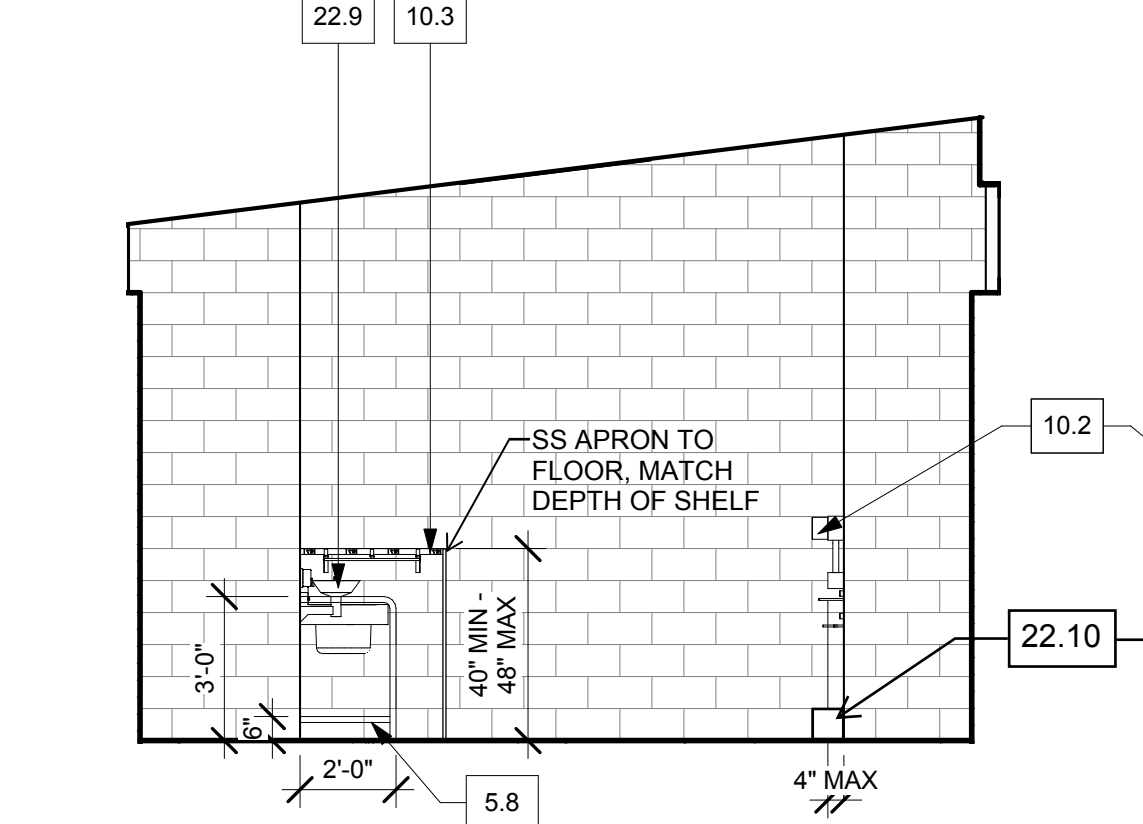
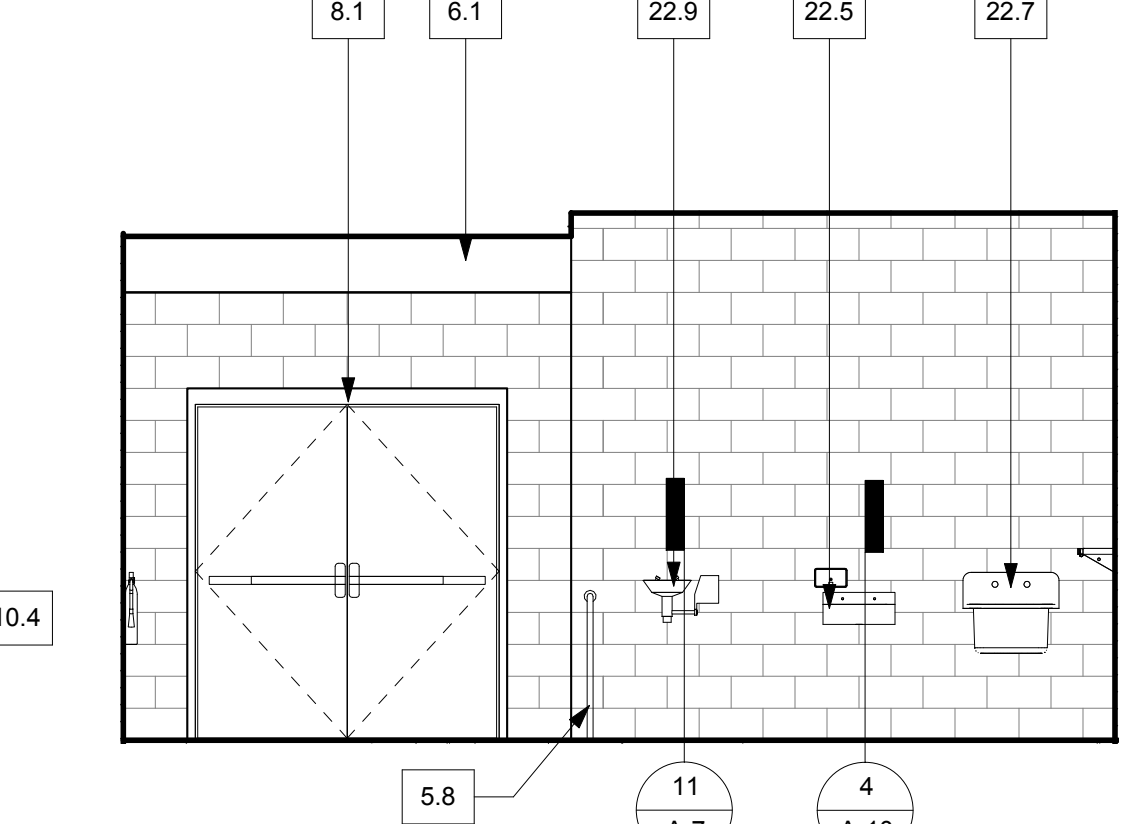
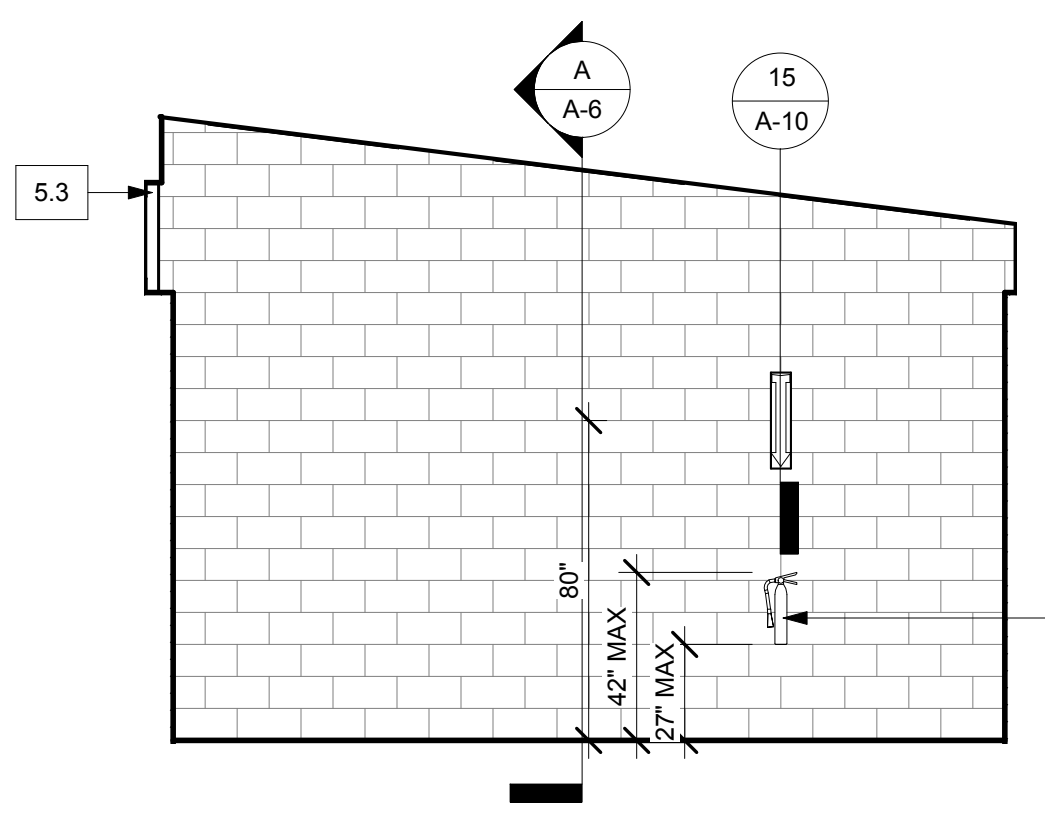
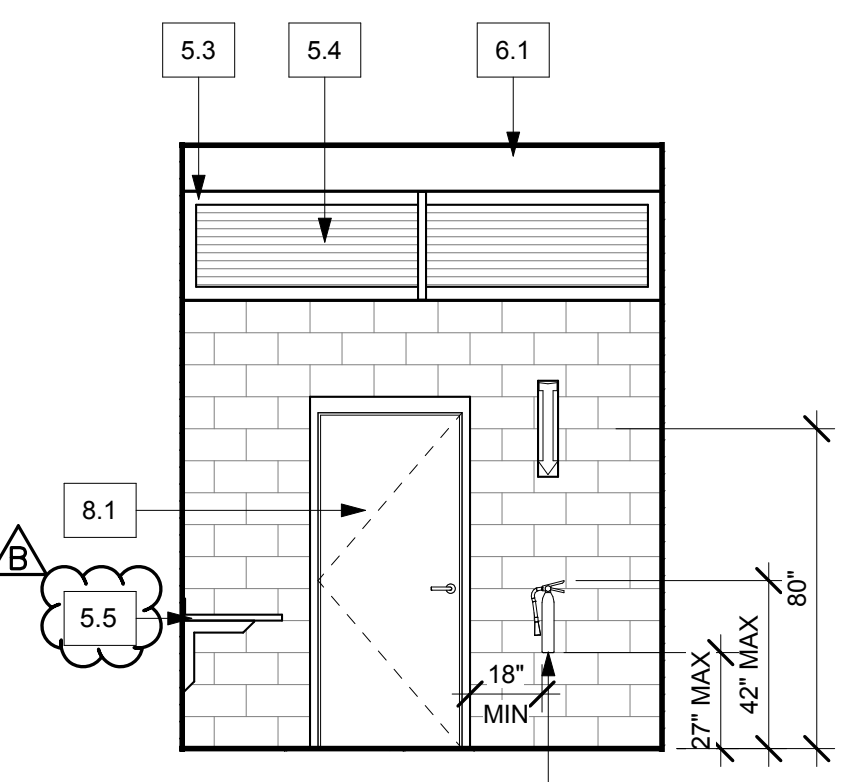
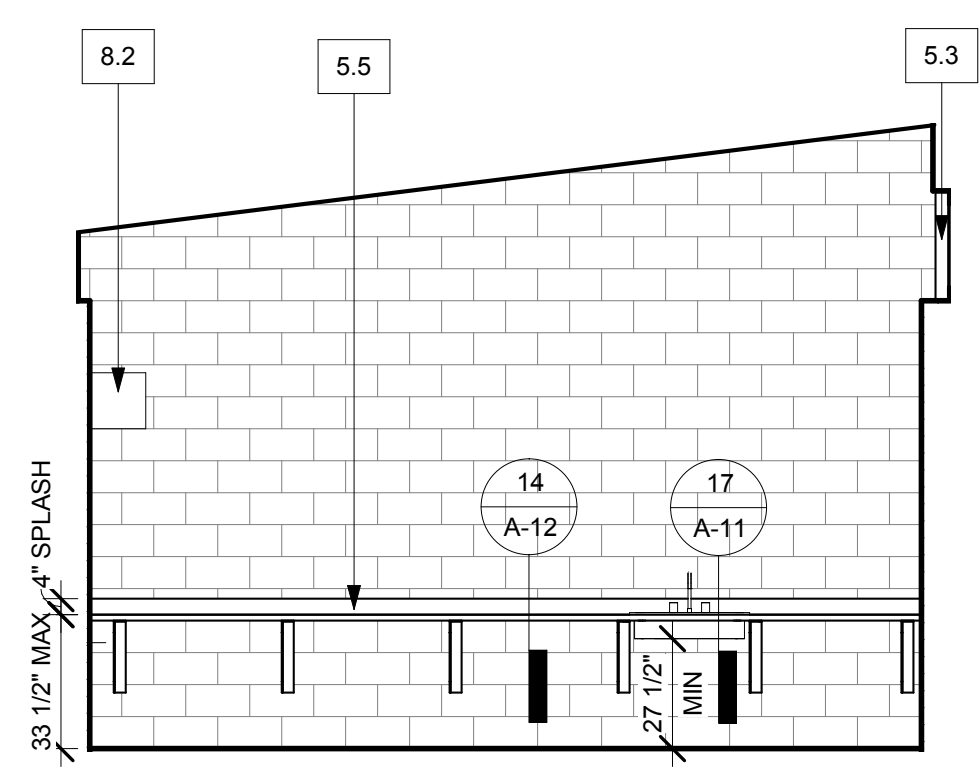
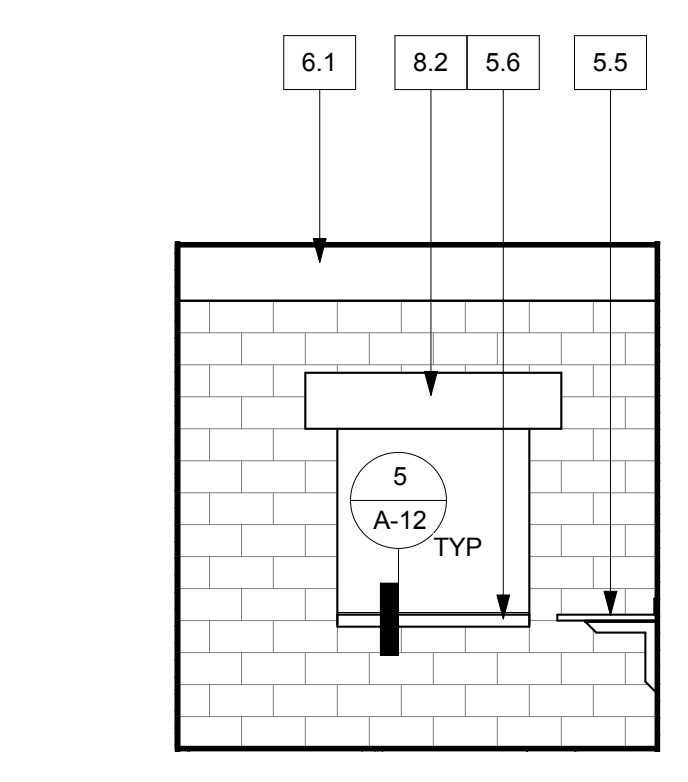
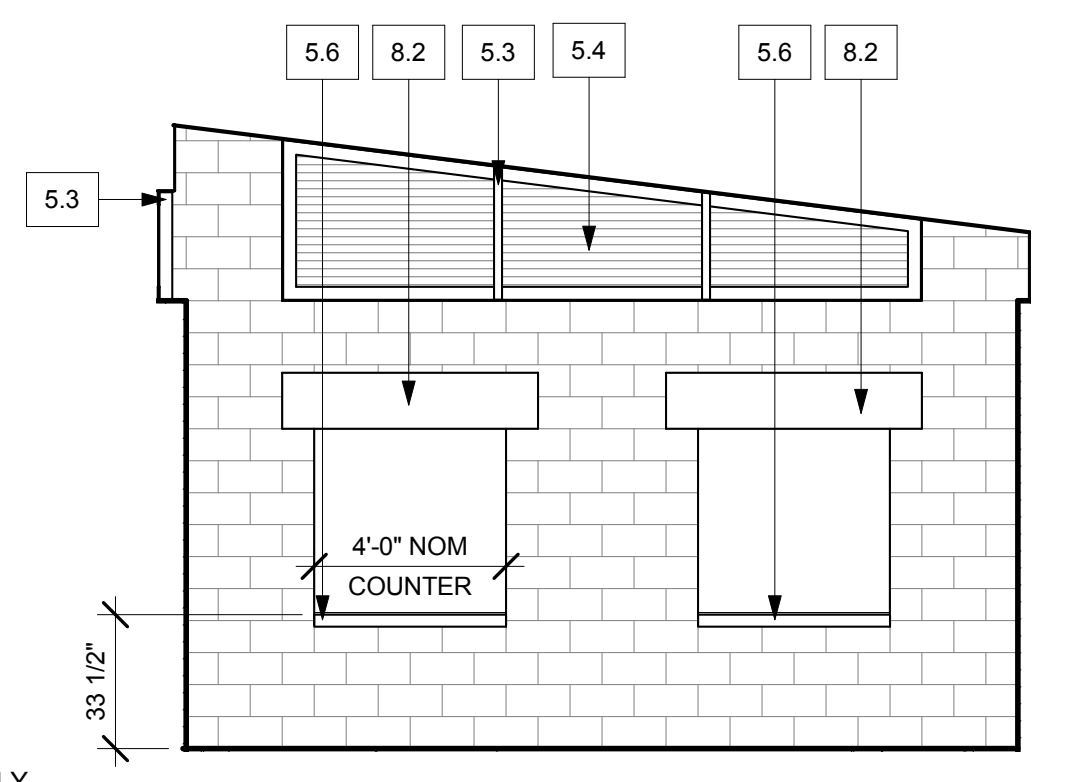
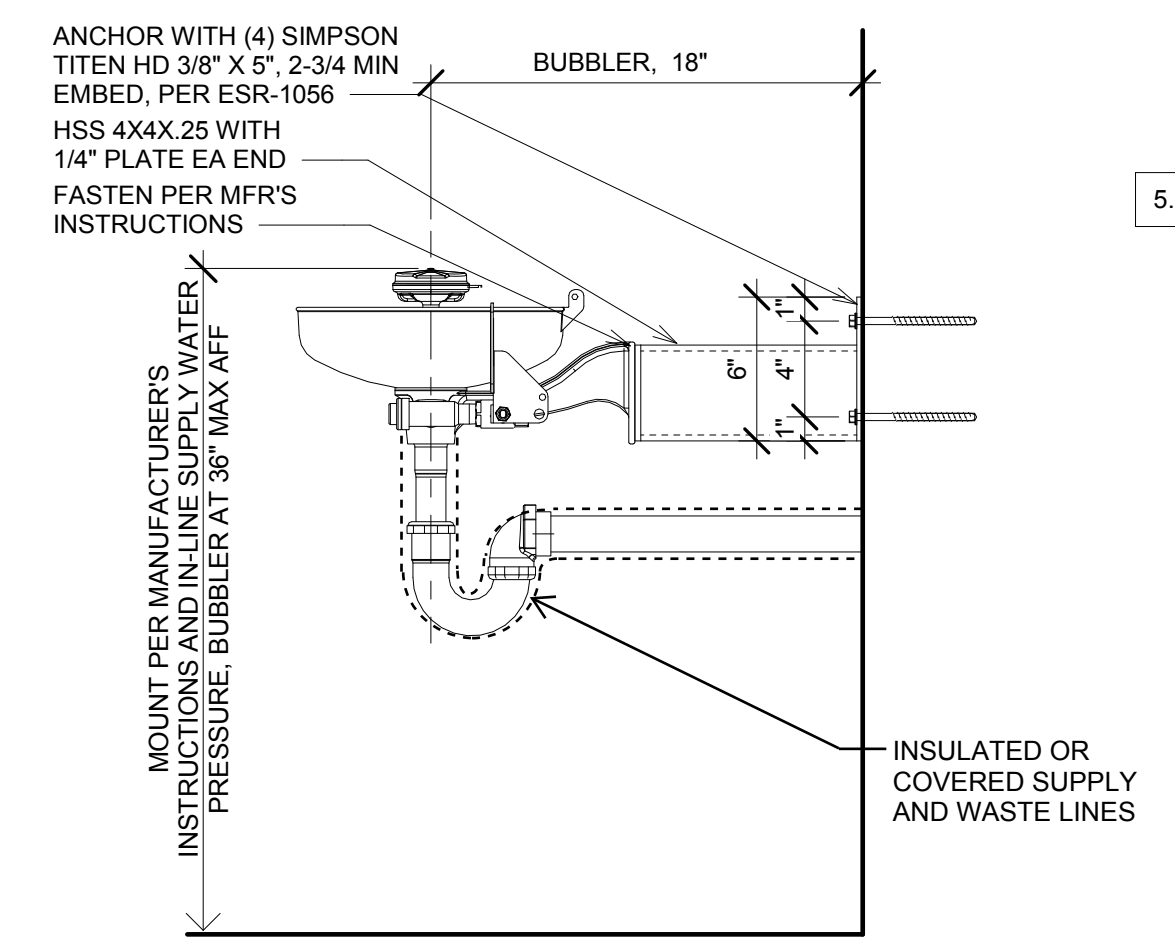

A-7

WANGENHEIM NEIGHBORHOOD JOINT USE FACILITY
ARCHITECTURAL ENLARGED PLANS, INTERIOR ELEVATIONS

SPEC. NO.		CITY OF SAN DIEGO, CALIFORNIA		WBS S-15007	
APPROVED:		10/13/2020		SUBMITTED BY: YOVANNA LEWIS	
FOR CITY ENGINEER: JASON GRANI		DATE: 7/20/20		PROJECT MANAGER	
PRINT NAME: JASON GRANI		RCE#: 77208		CHECKED BY: MEHDI RASHIDPOUR-HARISI	
DESCRIPTION	BY	APPROVED	DATE	FILMED	
ORIGINAL	REC				270-1731 (NAD27)
ADDENDUM B	REC		1/11/2021		CCS27 COORDINATE
					1910-6291 (NAD83)
					CCS83 COORDINATE
CONTRACTOR			DATE STARTED	40846-80-D	
INSPECTOR			DATE COMPLETED		

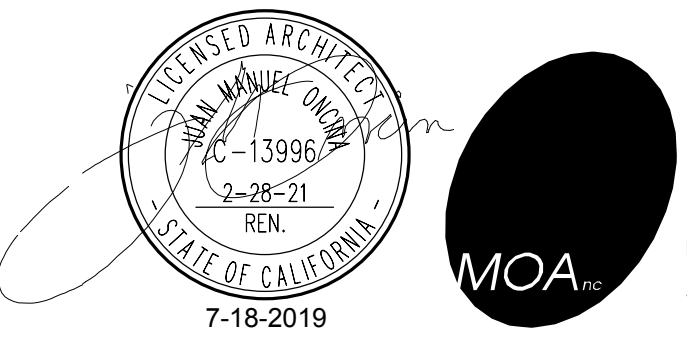

MANUEL ONCINA ARCHITECTS INC.
 ARCHITECTURE PLANNING
 5711 La Jolla Blvd
 La Jolla, CA 92037
 tel 858/459.1221
 fax 858/459.1214
 www.oncinaarc.com



IDENTIFICATION STAMP
 DIV. OF THE STATE ARCHITECT
 APP. 04-118244 INC.
 REVIEWED FOR
 SS FLS ACS
 DATE: 02.14.2020

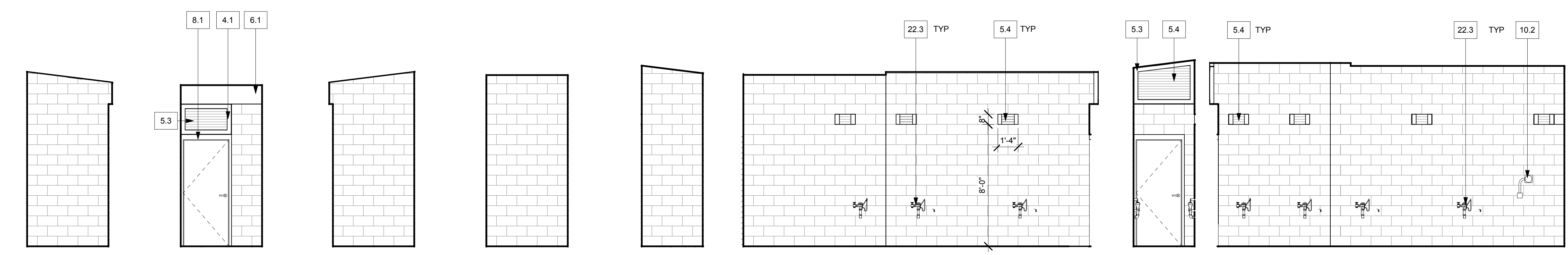

ELEC RM (E) 1/4" = 1'-0" **8** **ELEC RM (S)** 1/4" = 1'-0" **7** **ELEC RM (W)** 1/4" = 1'-0" **6** **ELEC RM (N)** 1/4" = 1'-0" **5** **CHASE (E)** 1/4" = 1'-0" **4** **CHASE (S)** 1/4" = 1'-0" **3** **CHASE (W)** 1/4" = 1'-0" **2** **CHASE (N)** 1/4" = 1'-0" **1**

- KEYNOTES**
- 4.1 CMU WALL, PER STRUCTURAL AND SECTION 04 22 00, TYPE AND PATTERN PER LEGEND
 - 5.3 STEEL ANGLE GRATING FRAME, PER SECTION 05 50 00, REFER TO SHEET A-5 FOR REFERENCES TO SUBSTRATE ATTACHMENT
 - 5.4 GALV STEEL GRATING WITH 1/8"x1/8" WIRE MESH, PER SECTION 05 53 13
 - 6.1 GLUE-LAMINATED BEAM, ARCHITECTURAL GRADE, PER STRUCTURAL AND SECTION 06 18 00
 - 8.1 DOOR, PER SCHED AND SECTION 08 11 13
 - 10.2 THROUGH-WALL CHASE-MOUNT HAND DRYER, 4" MAX PROJECTION ALLOWED FROM FACE OF WALL
 - 22.1 ACCESSIBLE TOILET, PER PLUMBING
 - 22.2 TOILET, PER PLUMBING
 - 22.3 THROUGH-WALL FLUSHOMETER, PER PLUMBING
 - 22.4 ACCESSIBLE LAVATORY, PER PLUMBING

- LEGEND**
- RUNNING BOND CMU
 - C4 BURNISHED CMU, PER EXTERIOR FINISH SCHEDULE

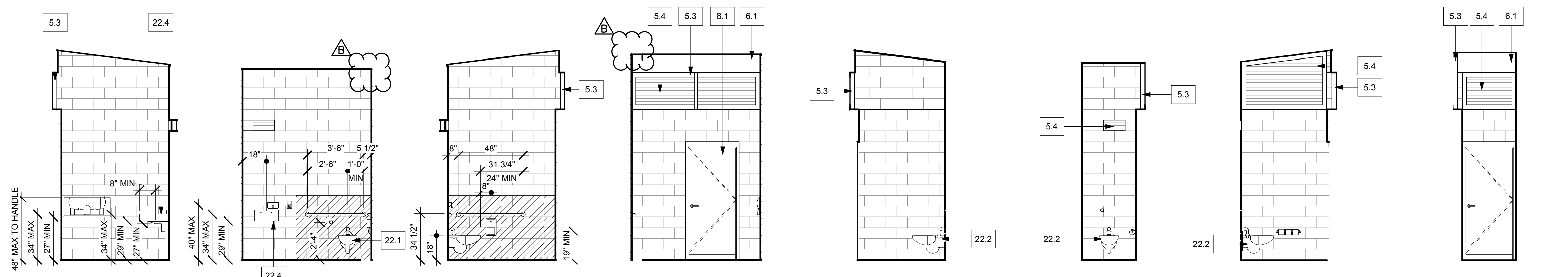

FAM RR (E) 1/4" = 1'-0" **16** **FAM RR (S)** 1/4" = 1'-0" **15** **FAM RR (W)** 1/4" = 1'-0" **14** **FAM RR (N)** 1/4" = 1'-0" **13** **TYP RR (E)** 1/4" = 1'-0" **12** **TYP RR (S)** 1/4" = 1'-0" **11** **TYP RR (W)** 1/4" = 1'-0" **10** **TYP RR (N)** 1/4" = 1'-0" **9**

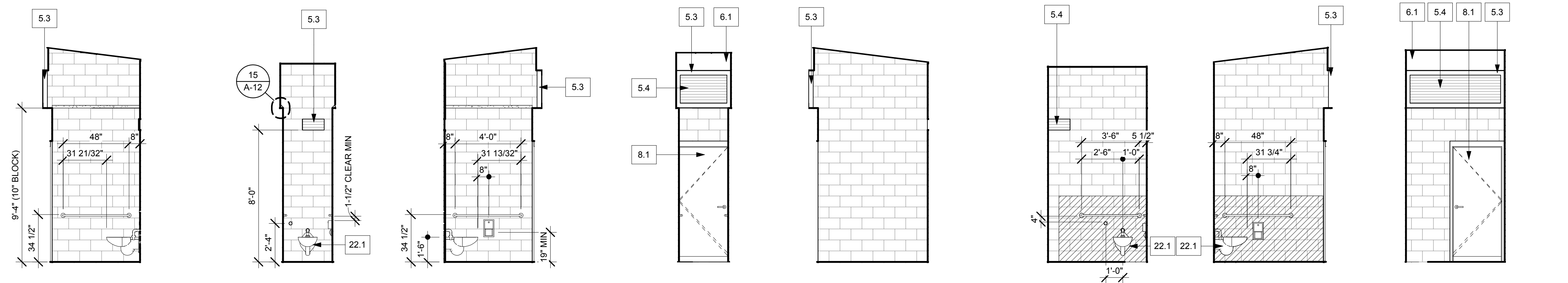

AMBULATORY ACCESSIBLE RESTROOM (E) 1/4" = 1'-0" **24** **AMBULATORY ACCESSIBLE RESTROOM (S)** 1/4" = 1'-0" **23** **AMBULATORY ACCESSIBLE RESTROOM (W)** 1/4" = 1'-0" **22** **AMBULATORY ACCESSIBLE RESTROOM (N)** 1/4" = 1'-0" **21** **TYP ACCESS (E)** 1/4" = 1'-0" **20** **TYP ACCESS (S)** 1/4" = 1'-0" **19** **TYP ACCESS (W)** 1/4" = 1'-0" **18** **TYP ACCESS (N)** 1/4" = 1'-0" **17**

- GENERAL PLAN NOTES:**
1. ALL DIMENSIONS FOR ACCESS COMPLIANCE ARE TO FACE OF FINISH UNLESS OTHERWISE NOTED.
 2. AREAS WITH FLOOR DRAINS AND SINKS SHALL HAVE SLOPES NOT STEEPER THAN 1:48 IN ALL DIRECTIONS. FLOOR SINKS OR DRAINS OR TROUGHS EXPOSED TO P.O.T. OR TO PEDESTRIAN CIRCULATION PATHS SHALL HAVE 1/2" MAX. GRATE OPENINGS IN ALL DIRECTIONS. (CBC Sec. 11B-302.3)
 3. OPERABLE PARTS OF ALL THE ACCESSIBLE ELEMENTS SHALL BE OPERABLE WITH ONE HAND AND SHALL NOT REQUIRE TIGHT GRASPING, PINCHING, OR TWISTING OF THE WRIST. THE FORCE REQUIRED TO ACTIVATE OPERABLE PARTS SHALL BE 5 POUNDS MAX. (CBC Sec. 11B-205 and 11B-309.4)

A-8

WANGENHEIM NEIGHBORHOOD JOINT USE FACILITY
ARCHITECTURAL INTERIOR ELEVATIONS

SPEC. NO.		CITY OF SAN DIEGO, CALIFORNIA PUBLIC WORKS DEPARTMENT SHEET OF 142 SHEETS		WBS S-15007
APPROVED:	10/13/2020	DATE	10/13/2020	SUBMITTED BY: YOVANNA LEWIS PROJECT MANAGER
FOR CITY ENGINEER	JASON GRANI	DATE	77208	CHECKED BY: MEHDI RASHIDPOUR-HARISI PROJECT ENGINEER
PRINT NAME	JASON GRANI	RCE#		
DESCRIPTION	BY	APPROVED	DATE	FILMED
ORIGINAL	REC			
ADDENDUM B	REC		1/11/2021	
DATE STARTED				270-1731 (NAD27)
DATE COMPLETED				1910-6291 (NAD83)
CONTRACTOR				40846-81-D
INSPECTOR				

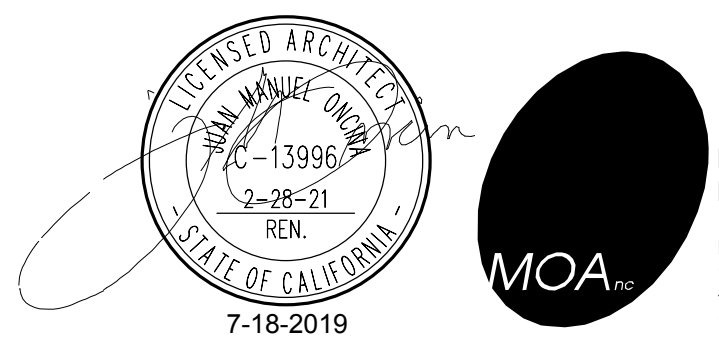

MANUEL ONCINA
 ARCHITECTS INC.
 ARCHITECTURE
 PLANNING
 INTERIORS
 5711 La Jolla Blvd
 La Jolla, CA 92037
 tel 858/459.1221
 fax 858/459.1214
 www.oncinaarc.com



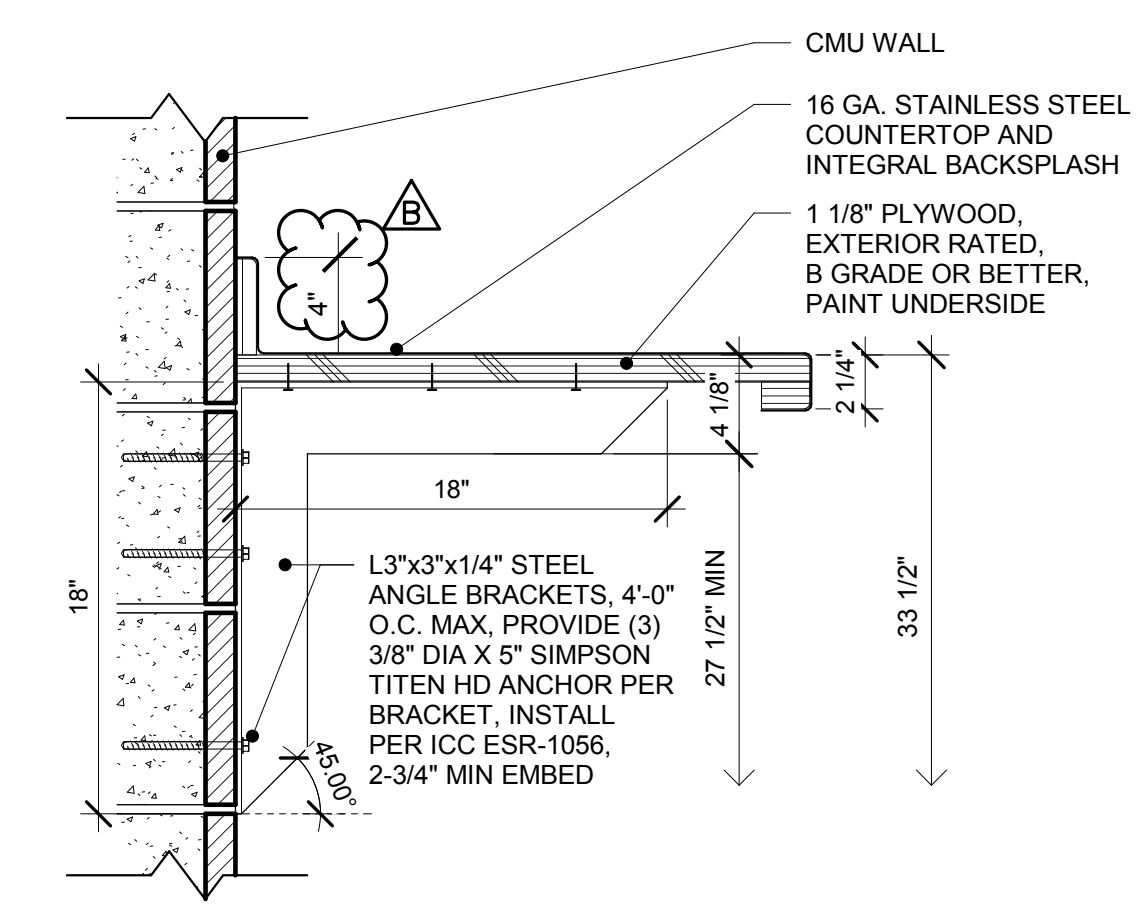

14 COUNTER AT CONCESSIONS
 1 1/2" = 1'-0"

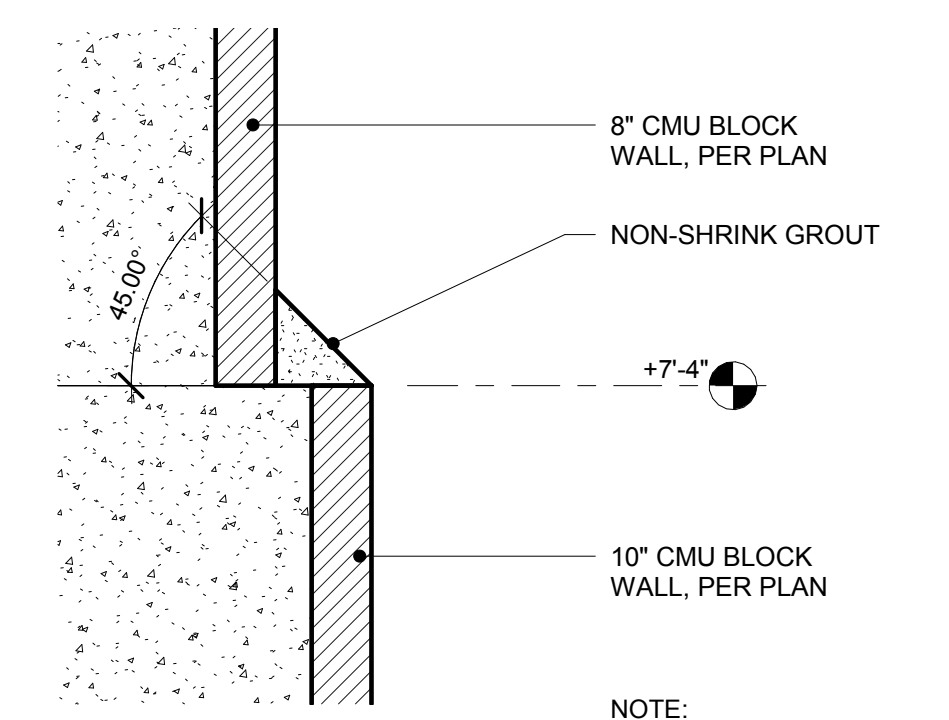

15 10" TO 8" CMU TRANSITION
 3" = 1'-0"

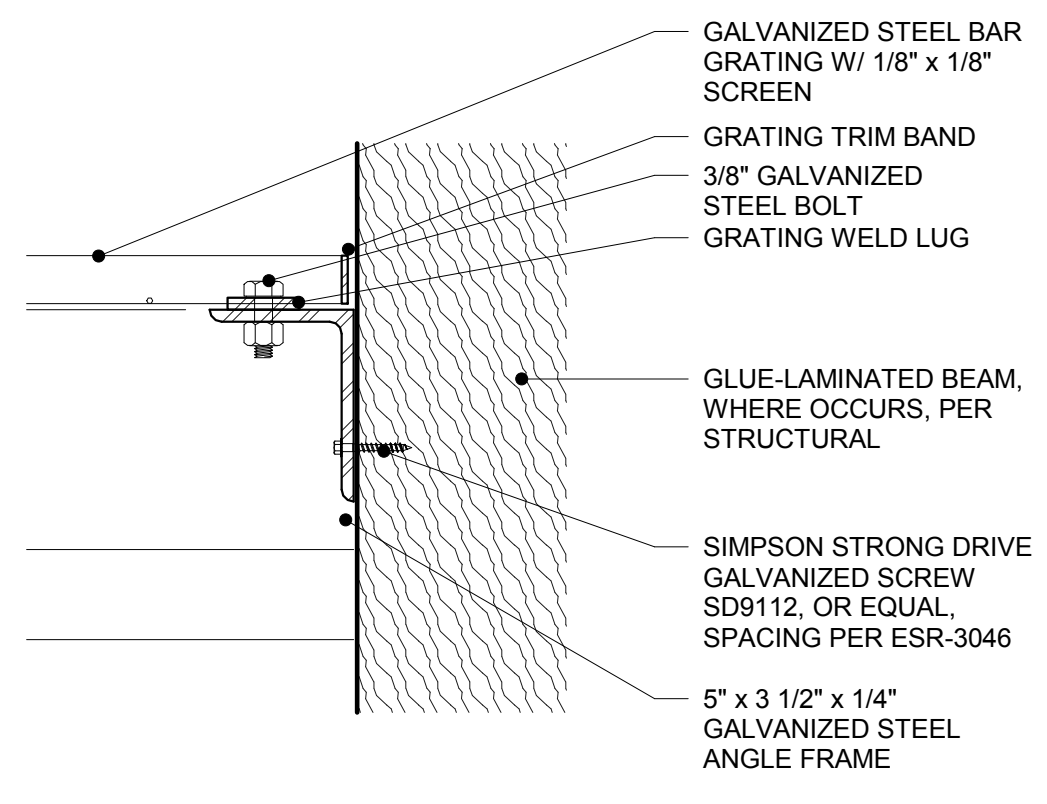

16 GRATING JAMB AT BEAM
 3" = 1'-0"

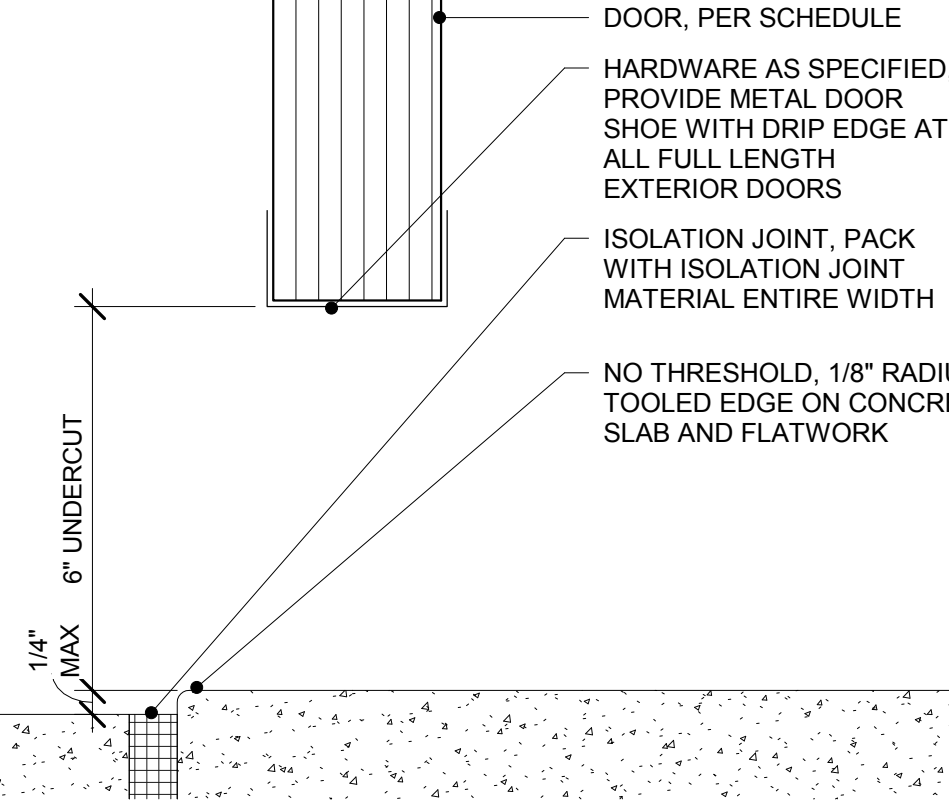

17 EXTERIOR DOOR SILL - NO THRESHOLD
 6" = 1'-0"

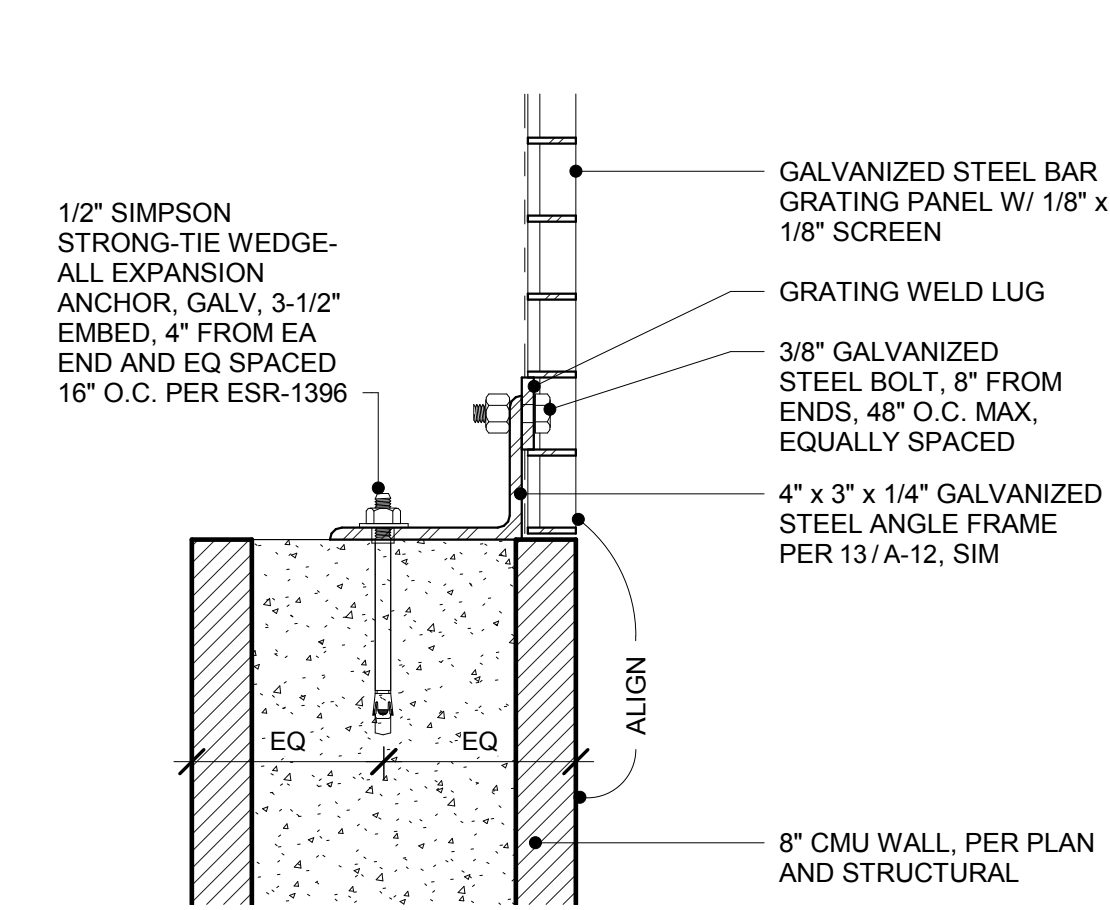

10 GRATING SILL AT CMU
 3" = 1'-0"

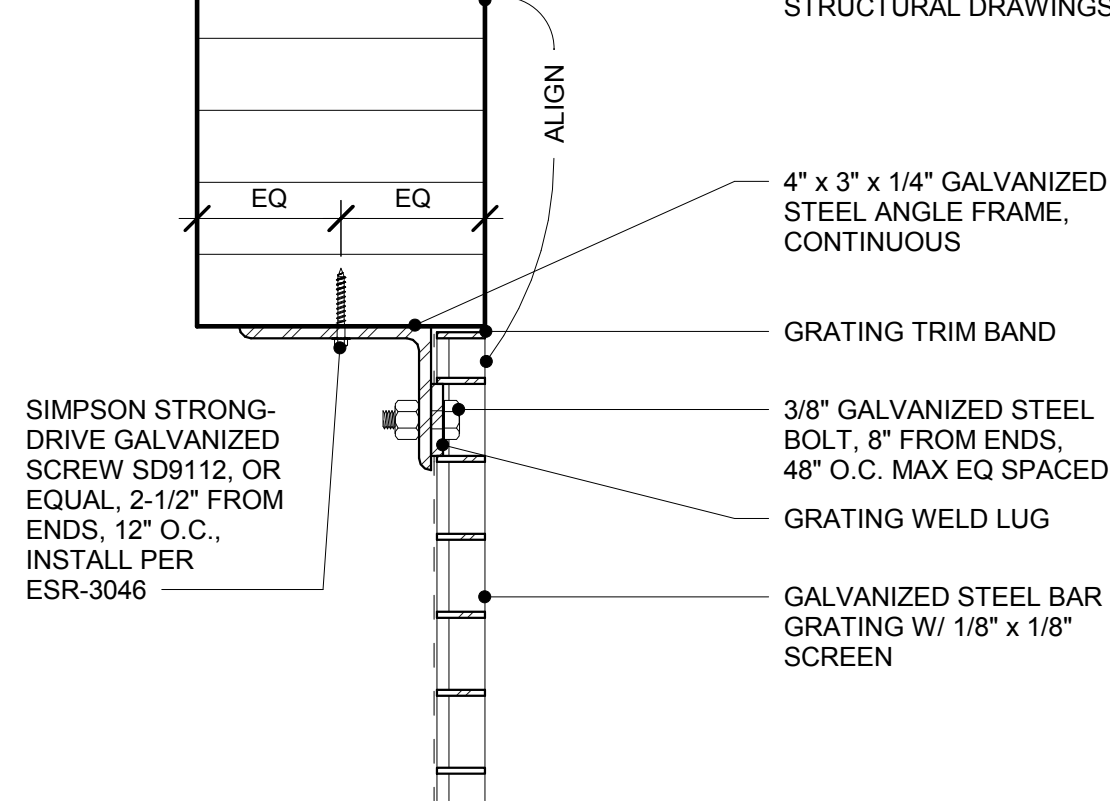

11 GRATING HEAD AT BEAM
 3" = 1'-0"

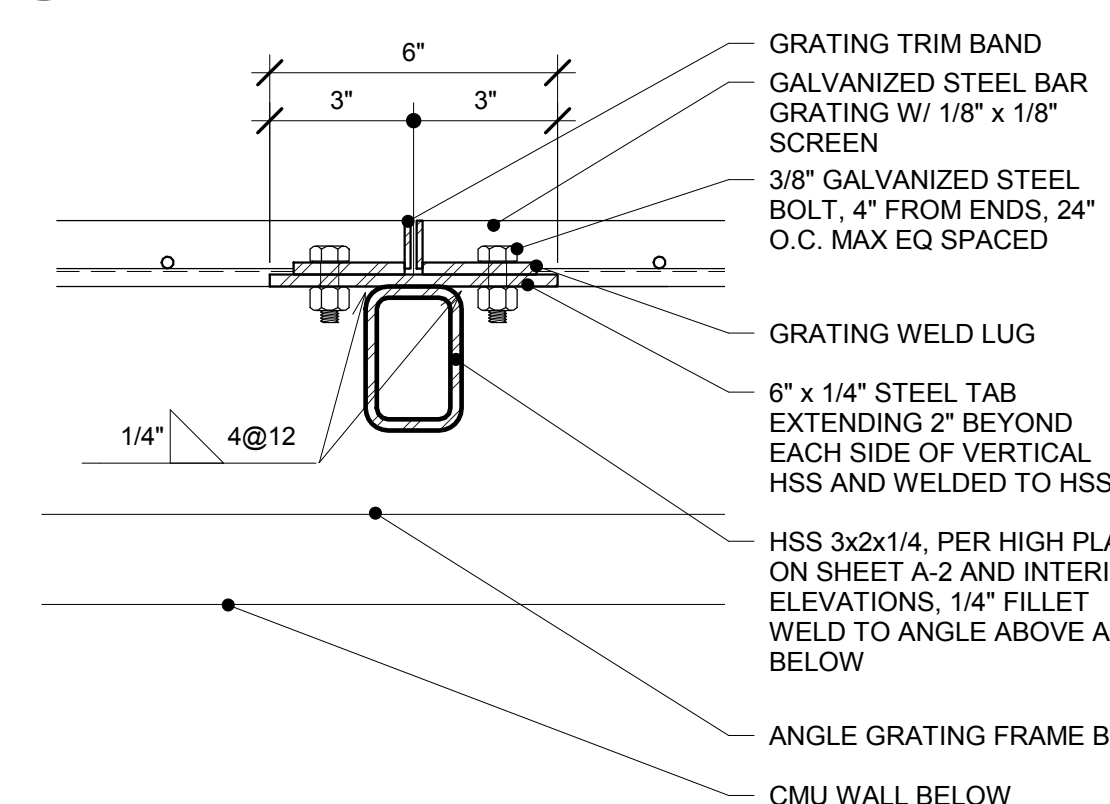

12 TYP PANEL JOINT
 3" = 1'-0"

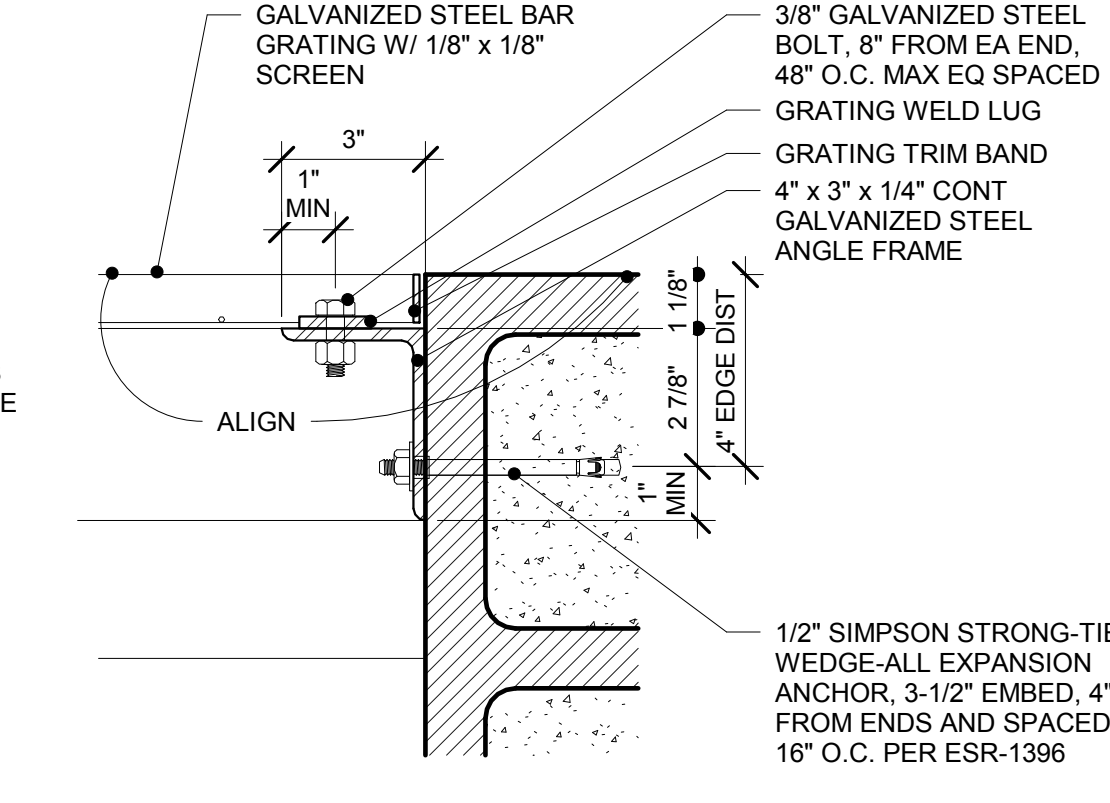

13 GRATING JAMB
 3" = 1'-0"

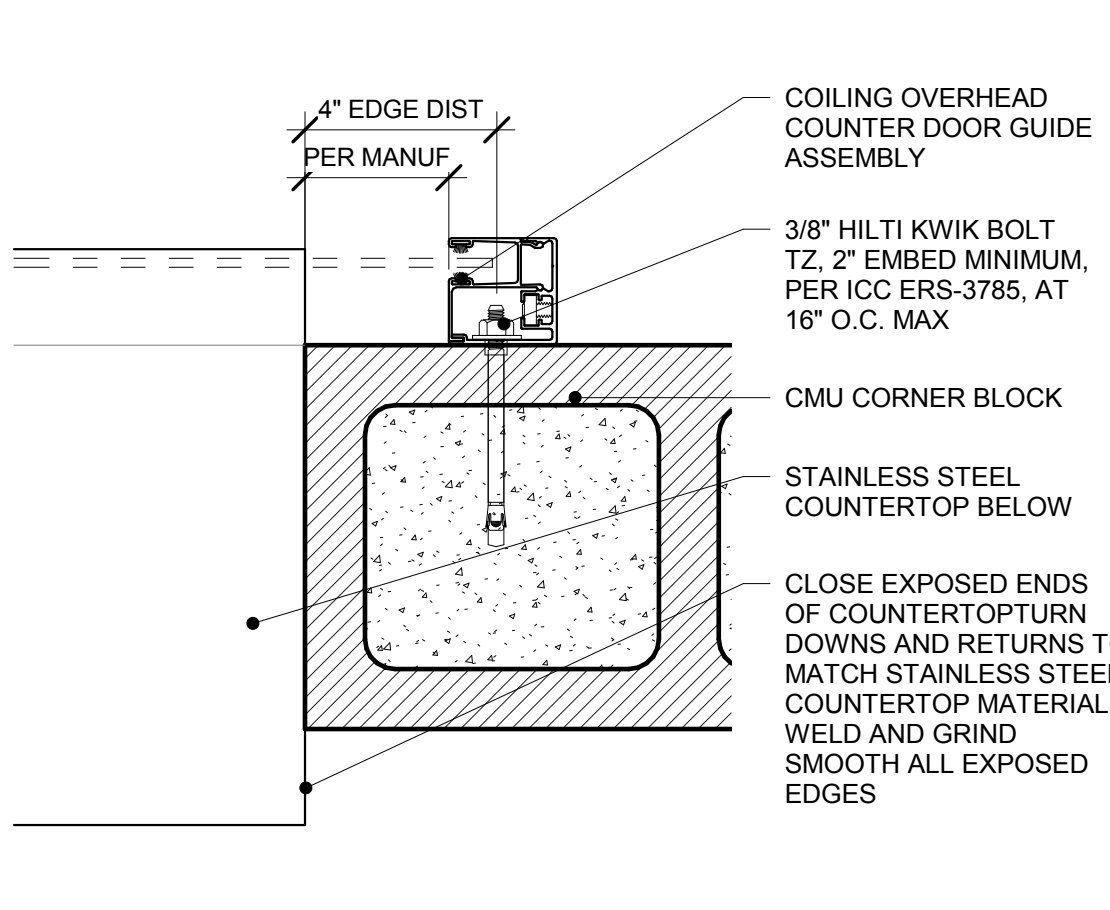

6 COILING COUNTER DOOR JAMB
 3" = 1'-0"

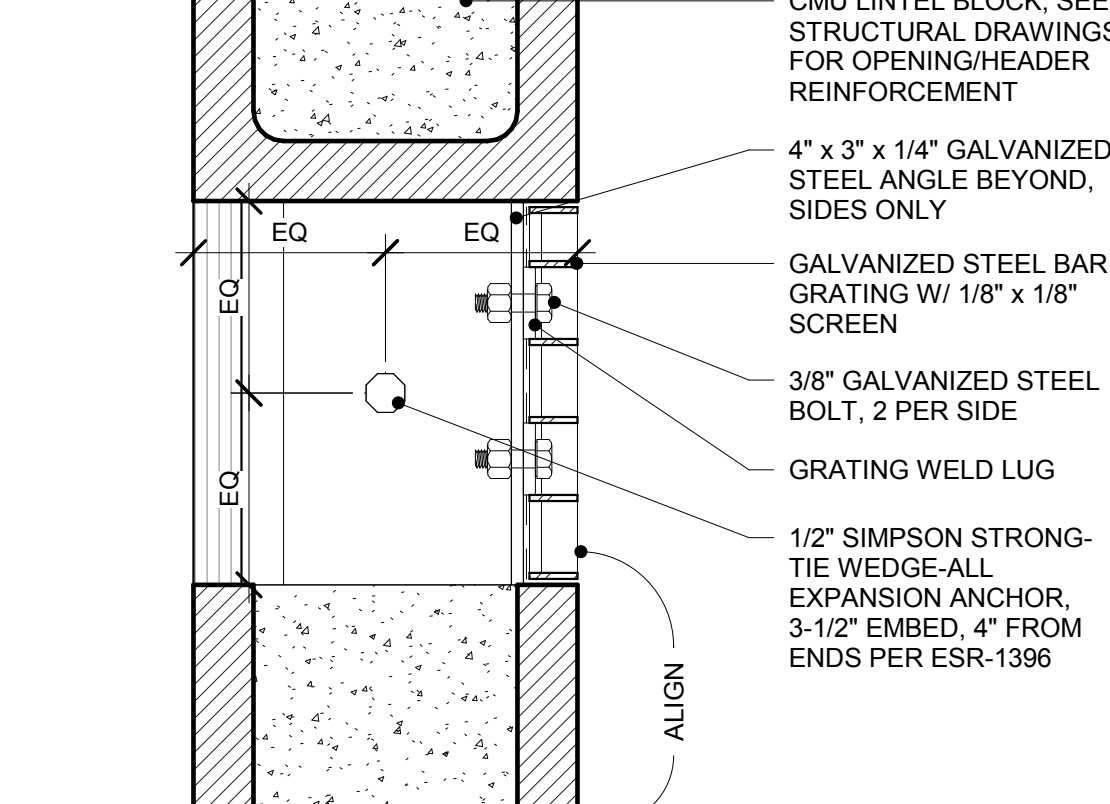

7 GRATING AT CMU OPENINGS
 NTS

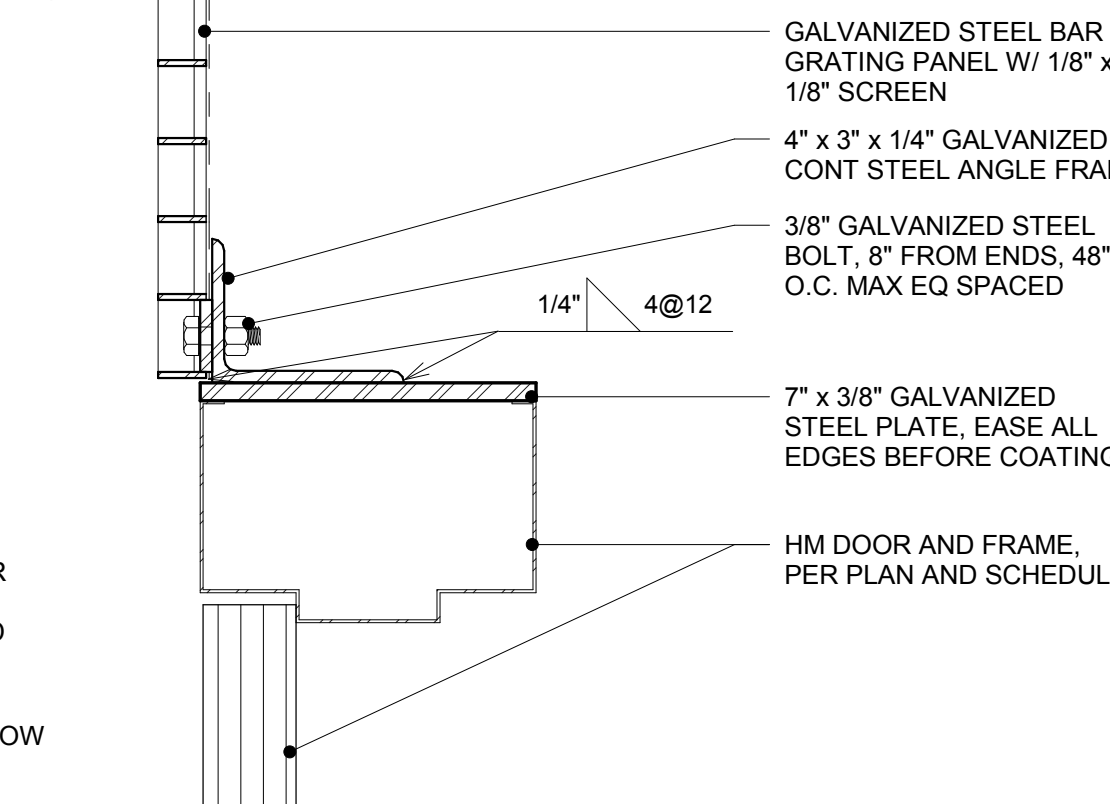

8 DOOR FRAME HEAD AT GRATING SILL
 3" = 1'-0"

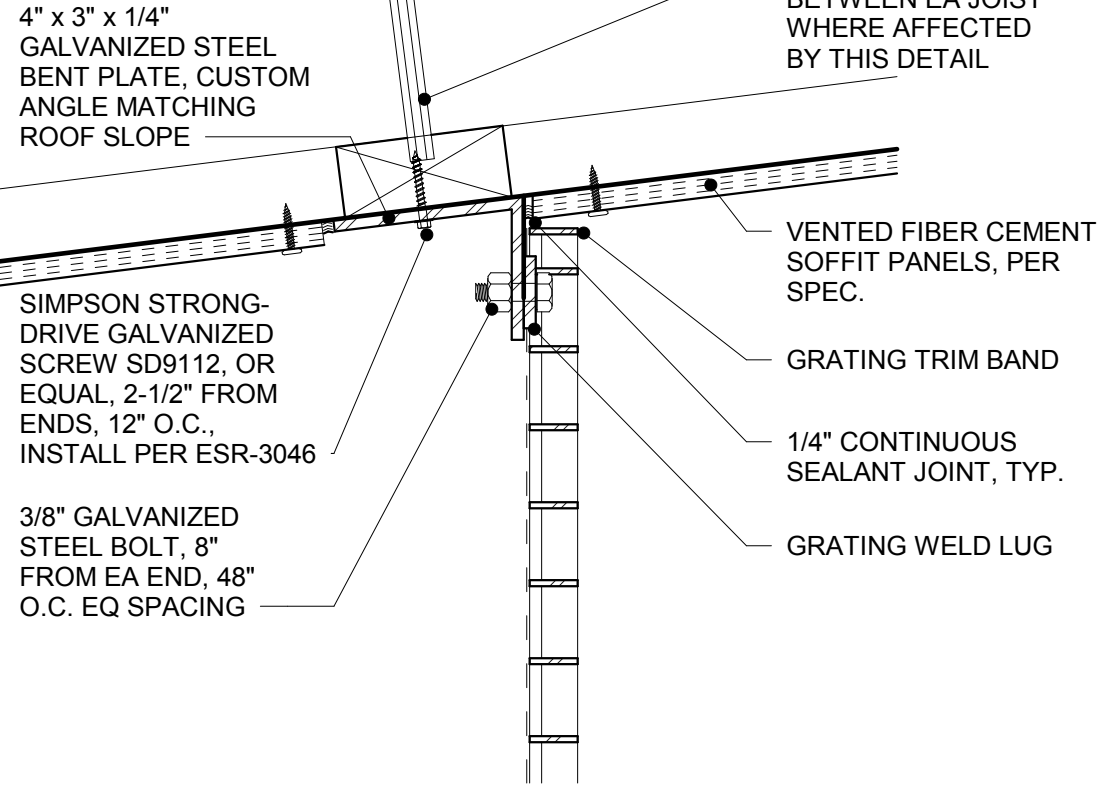

9 GRATING PANEL HEAD AT ROOF
 3" = 1'-0"

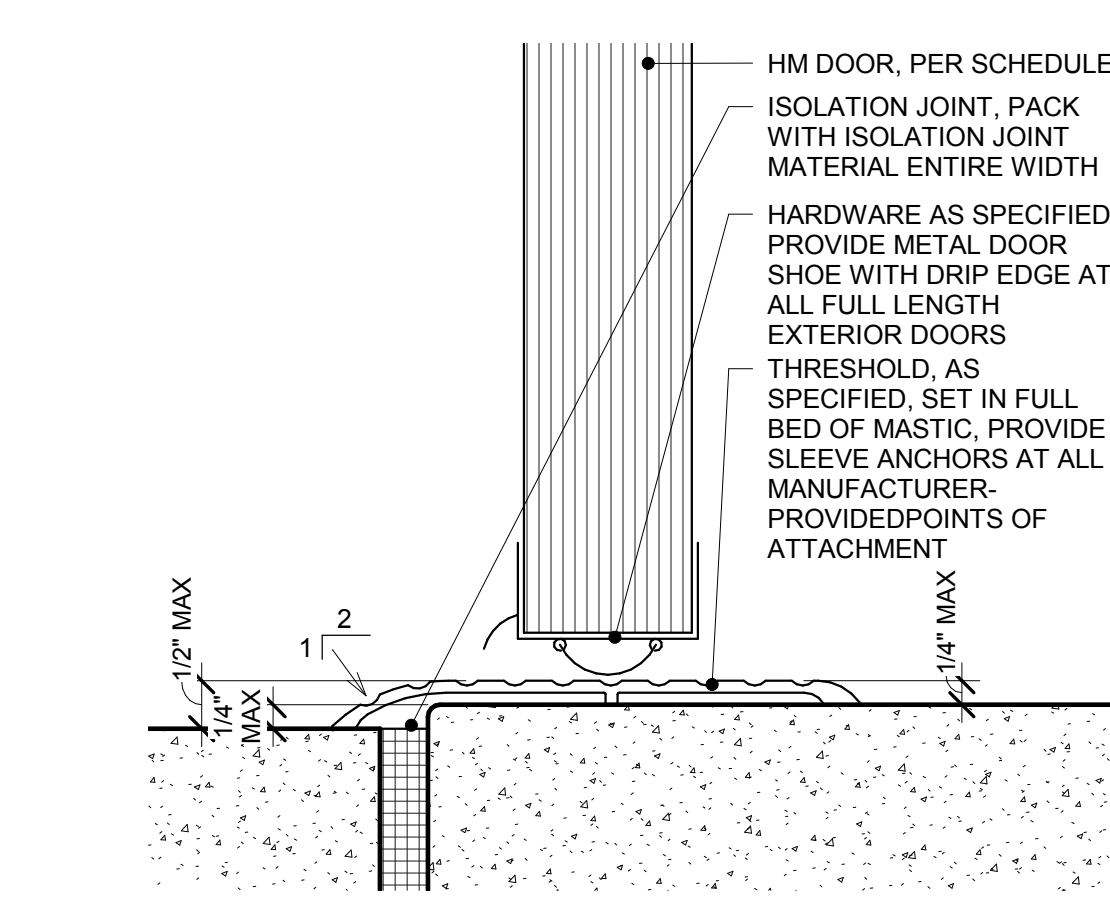

3 EXTERIOR DOOR SILL
 6" = 1'-0"

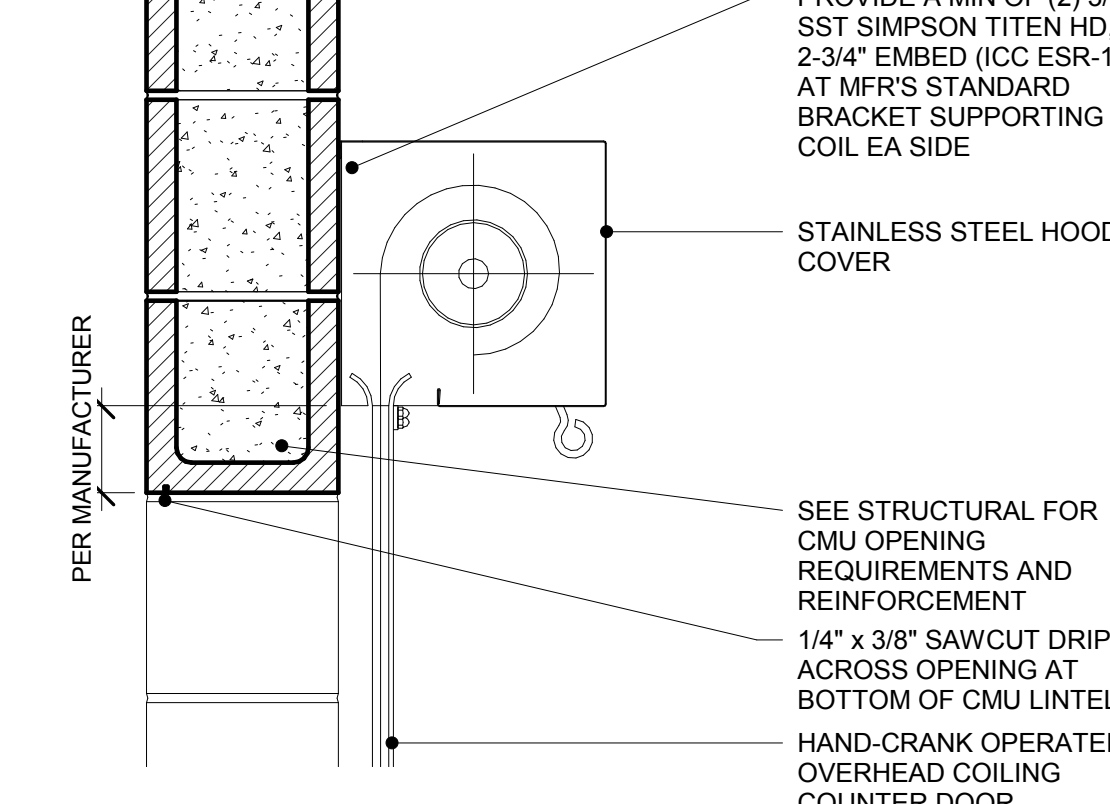

4 COILING COUNTER DOOR HEAD
 1 1/2" = 1'-0"

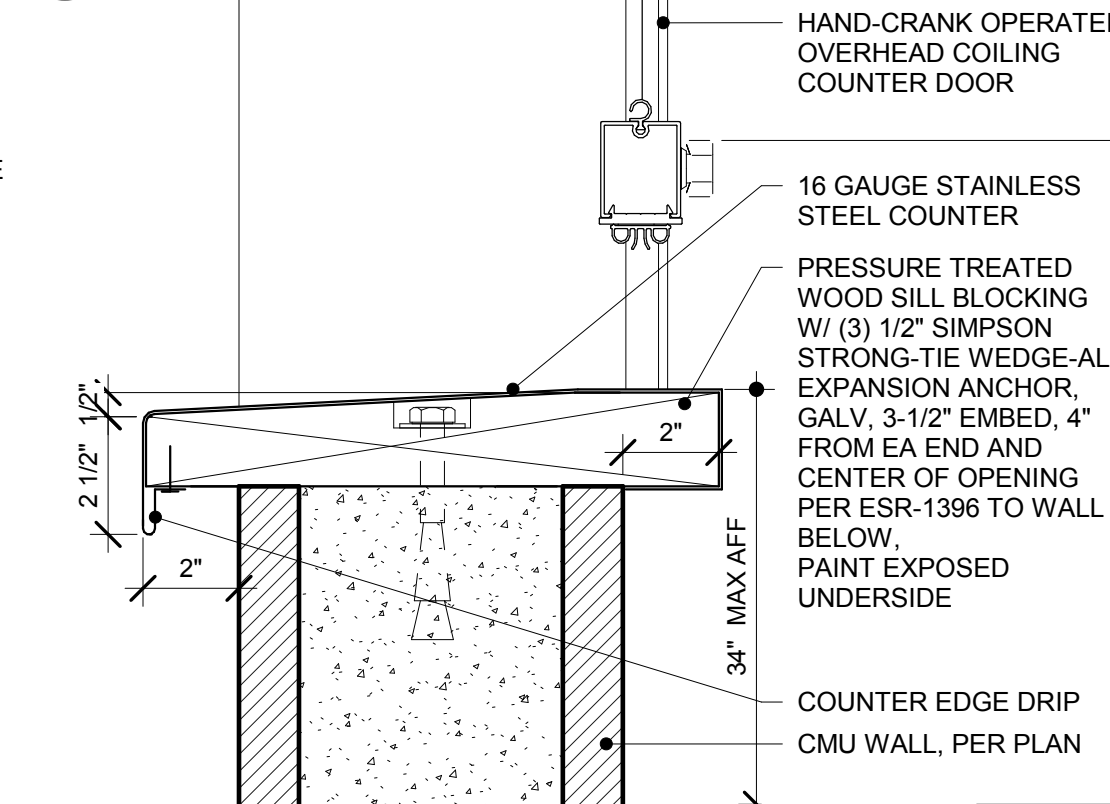

5 COILING COUNTER DOOR SILL
 3" = 1'-0"

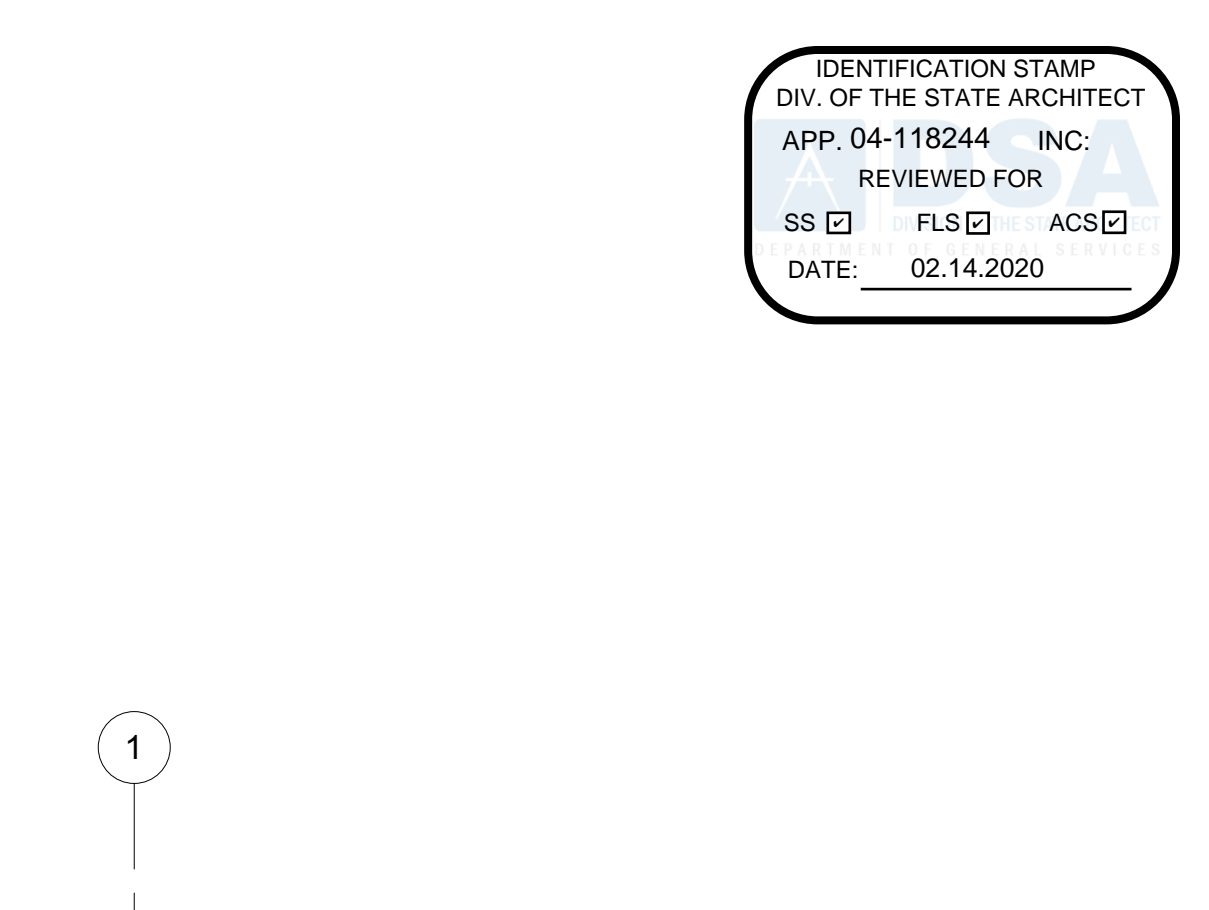

1 DOOR FRAME HEAD
 3" = 1'-0"

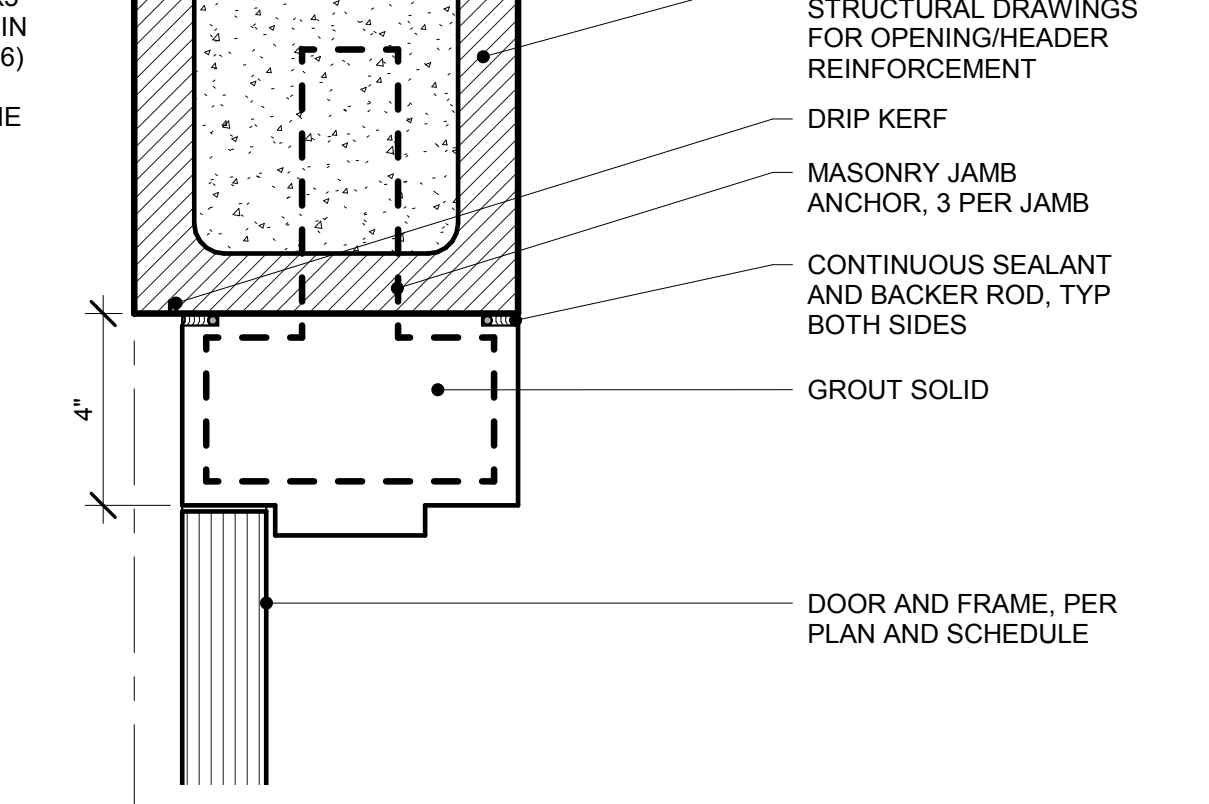

2 DOOR FRAME JAMB
 3" = 1'-0"

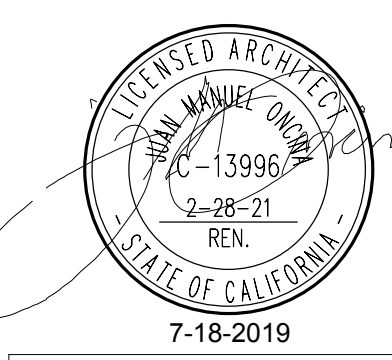

WANGENHEIM NEIGHBORHOOD JOINT USE FACILITY
ARCHITECTURAL DETAILS

SPEC. NO.		CITY OF SAN DIEGO, CALIFORNIA PUBLIC WORKS DEPARTMENT SHEET 85 OF 142 SHEETS		WBS	S-15007			
APPROVED:	DATE	10/13/2020	77208	SUBMITTED BY:	YOVANNA LEWIS PROJECT MANAGER			
FOR CITY ENGINEER	DATE	10/13/2020	77208	CHECKED BY:	MEHDI RASHIDPOUR-HARISI PROJECT ENGINEER			
PRINT NAME	RCE#			DESCRIPTION	BY	APPROVED	DATE	FILMED
ORIGINAL	REC							
ADDENDUM B	REC						1/11/2021	
				NO. C17208	270-1731 (NAD27)			
				1910-6291 (NAD83)	CCS27 COORDINATE			
				40846-85-D	CCS83 COORDINATE			
CONTRACTOR	INSPECTOR	DATE STARTED	DATE COMPLETED					



MANUEL ONCINA ARCHITECTS INC.
 ARCHITECTURE PLANNING
 5711 La Jolla Blvd
 La Jolla, CA 92037
 tel 858/459.1211
 fax 858/459.1214
 www.oncinaarc.com

Project Name:	17056_Snack Bar	NRCC-PRF-01-E	Page 3 of 16
Project Address:	NewEnvelopeAndMechanical	Calculation Date/Time:	11:22, Tue, Feb 04, 2020
Compliance Scope:	NewEnvelopeAndMechanical	Input File Name:	17056_T24.cibd16x

G. COMPLIANCE PATH & CERTIFICATE OF COMPLIANCE SUMMARY

Identify which building components use the performance or prescriptive path for compliance. "NA"= not in project
For components that utilize the performance path, indicate the sheet number that includes mandatory notes on plans

Building Component	Compliance Path	Compliance Forms (required for submittal)	Location of Mandatory Notes on Plans
Envelope	<input checked="" type="checkbox"/> Performance	NRCC-PRF-ENV-DETAILS (section of the NRCC-PRF-01-E)	
	<input type="checkbox"/> Prescriptive	NRCC-ENV-01 / 02 / 03 / 04 / 05 / 06-E	
	<input type="checkbox"/> NA		
Mechanical	<input checked="" type="checkbox"/> Performance	NRCC-PRF-MCH-DETAILS (section of the NRCC-PRF-01-E)	
	<input type="checkbox"/> Prescriptive	NRCC-MCH-01 / 02 / 03 / 04 / 05 / 06 / 07-E	
	<input type="checkbox"/> NA		
Domestic Hot Water	<input checked="" type="checkbox"/> Performance	NRCC-PRF-PLB-DETAILS (section of the NRCC-PRF-01-E)	
	<input type="checkbox"/> Prescriptive	NRCC-PLB-01-E	
	<input type="checkbox"/> NA		
Lighting (Indoor Conditioned)	<input checked="" type="checkbox"/> Performance	NRCC-PRF-LTI-DETAILS (section of the NRCC-PRF-01-E)	
	<input type="checkbox"/> Prescriptive	NRCC-LTI-01 / 02 / 03 / 04 / 05-E	
	<input type="checkbox"/> NA		
Covered Process: Commercial Kitchens	<input checked="" type="checkbox"/> Performance	S3 (section of the NRCC-PRF-01-E)	
	<input type="checkbox"/> Prescriptive	NRCC-PRC-01/ 03-E	
	<input type="checkbox"/> NA		
Covered Process: Computer Rooms	<input checked="" type="checkbox"/> Performance	S3 (section of the NRCC-PRF-01-E)	
	<input type="checkbox"/> Prescriptive	NRCC-PRC-01/ 04-E	
	<input type="checkbox"/> NA		
Covered Process: Laboratory Exhaust	<input checked="" type="checkbox"/> Performance	S4 (section of the NRCC-PRF-01-E)	
	<input type="checkbox"/> Prescriptive	NRCC-PRC-01/ 09-E	
	<input type="checkbox"/> NA		

Project Name:	17056_Snack Bar	NRCC-PRF-01-E	Page 2 of 16
Project Address:	NewEnvelopeAndMechanical	Calculation Date/Time:	11:22, Tue, Feb 04, 2020
Compliance Scope:	NewEnvelopeAndMechanical	Input File Name:	17056_T24.cibd16x

C. PRIORITY PLAN CHECK/ INSPECTION ITEMS (in order of highest to lowest TDV energy savings)

Item	Description	Compliance Margin By Energy Component (from Table B column 4)
1st	Indoor Fans: Check envelope and mechanical	<div style="display: flex; justify-content: space-between;"> <div style="border: 1px solid black; padding: 5px;">Indoor Fans</div> <div style="border: 1px solid black; padding: 5px;">Space Cooling</div> </div>
2nd	Space Cooling: Check envelope and mechanical	
3rd	Heat Rejection: Check envelope and mechanical	
4th	Pumps & Misc.: Check mechanical	
5th	Domestic Hot Water: Check mechanical	
6th	Indoor Lighting: Check lighting	
7th	Space Heating: Check envelope and mechanical	<div style="display: flex; justify-content: space-between;"> <div style="border: 1px solid black; padding: 5px;">Domestic Hot Water</div> <div style="border: 1px solid black; padding: 5px;">Pumps & Misc.</div> <div style="border: 1px solid black; padding: 5px;">Indoor Lighting</div> <div style="border: 1px solid black; padding: 5px;">Space Heating</div> </div>

D. EXCEPTIONAL CONDITIONS

This project includes partial performance compliance scope options. The building must show compliance with all other applicable compliance scope options (performance or prescriptively) before occupying.

The building does not include service water heating. Verify that service water heating is not required and is not included in the design.

The user model includes space(s) that are designed to be served by mechanical cooling systems, but the cooling systems were not included in the simulation model. A cooling system has been modeled for both the proposed and standard cases.

E. HERS VERIFICATION

This Section Does Not Apply

F. ADDITIONAL REMARKS

None Provided

Project Name:	17056_Snack Bar	NRCC-PRF-01-E	Page 1 of 16
Project Address:	NewEnvelopeAndMechanical	Calculation Date/Time:	11:22, Tue, Feb 04, 2020
Compliance Scope:	NewEnvelopeAndMechanical	Input File Name:	17056_T24.cibd16x

A. PROJECT GENERAL INFORMATION

1. Project Location (city)	- specify -	8. Standards Version	Compliance2016
2. CA Zip Code		9. Compliance Software (version)	EnergyPro 7.2
3. Climate Zone	7	10. Weather File	IMPERIAL-BEACH_72909_CZ2010.epw
4. Total Conditioned Floor Area in Scope	170 ft ²	11. Building Orientation (deg)	(N) 0 deg
5. Total Unconditioned Floor Area	0 ft ²	12. Permitted Scope of Work	NewEnvelopeAndMechanical
6. Total # of Stories (Habitable Above Grade)	1	13. Building Type(s)	Nonresidential
7. Total # of dwelling units	0	14. Gas Type	NaturalGas

B. COMPLIANCE RESULTS FOR PERFORMANCE COMPONENTS (Annual TDV Energy Use, kBtu/ft²-yr) § 140.1

BUILDING COMPLIES				
1. Energy Component	2. Standard Design (TDV)	3. Proposed Design (TDV)	4. Compliance Margin (TDV)	5. Percent Better than Standard
Space Heating	14.33	84.59	-70.26	-490.3%
Space Cooling	32.57	25.33	7.24	22.2%
Indoor Fans	100.66	6.45	94.21	93.6%
Heat Rejection	--	--	--	--
Pumps & Misc.	--	--	--	--
Domestic Hot Water	3.64	3.64	--	0.0%
Indoor Lighting	103.60	103.60	--	0.0%
COMPLIANCE TOTAL	254.80	223.61	31.19	12.2%
Receptacle	91.02	91.02	0.0	0.0%
Process	--	--	--	--
Other Ltg	--	--	--	--
Process Motors	--	--	--	--
TOTAL	345.82	314.63	31.2	9.0%

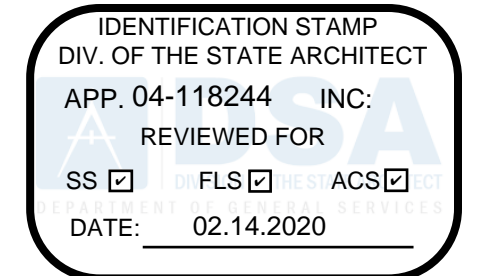

CA Building Energy Efficiency Standards- 2016 Nonresidential Compliance Report Version: NRCC-PRF-01-E-06262019-5583 Report Generated at: 2020-02-04 11:23:37

CA Building Energy Efficiency Standards- 2016 Nonresidential Compliance Report Version: NRCC-PRF-01-E-06262019-5583 Report Generated at: 2020-02-04 11:23:37

CA Building Energy Efficiency Standards- 2016 Nonresidential Compliance Report Version: NRCC-PRF-01-E-06262019-5583 Report Generated at: 2020-02-04 11:23:37

Project Name:	17056_Snack Bar	NRCC-PRF-01-E	Page 4 of 16
Project Address:	NewEnvelopeAndMechanical	Calculation Date/Time:	11:22, Tue, Feb 04, 2020
Compliance Scope:	NewEnvelopeAndMechanical	Input File Name:	17056_T24.cibd16x

G. COMPLIANCE PATH & CERTIFICATE OF COMPLIANCE SUMMARY

The following building components are only eligible for prescriptive compliance. Indicate which are relevant to the project.

Yes	NA	Prescriptive Requirement	Compliance Forms	Yes	NA	Mandatory Requirement	Compliance Forms
<input type="checkbox"/>	<input checked="" type="checkbox"/>	Lighting (Indoor Unconditioned) §140.6	NRCC-LTI-01 / 02 / 03 / 04 / 05-E	<input type="checkbox"/>	<input checked="" type="checkbox"/>	Commissioning: §120.8 Simple Systems Complex Systems	NRCC-CXR-01 / 02 / 03 / 05-E NRCC-CXR-01 / 02 / 04 / 05-E
<input type="checkbox"/>	<input checked="" type="checkbox"/>	Lighting (Outdoor) §140.7	NRCC-LTO-01 / 02 / 03-E	<input type="checkbox"/>	<input checked="" type="checkbox"/>	Electrical: §130.5	NRCC-ELC-01-E
<input type="checkbox"/>	<input checked="" type="checkbox"/>	Lighting (Sign) §140.8	NRCC-LTS-01-E	<input type="checkbox"/>	<input checked="" type="checkbox"/>	Solar Ready: §110.10	NRCC-SRA-01 / 02-E
<input type="checkbox"/>	<input checked="" type="checkbox"/>	Solar Thermal Water Heating: §140.5	NRCC-STH-01-E	<input type="checkbox"/>	<input checked="" type="checkbox"/>	Covered Process: §120.6 Parking Garage Commercial Refrigeration Warehouse Refrigeration Compressed Air Process Boilers	NRCC-PRC-01-E NRCC-PRC-02-E NRCC-PRC-05-E NRCC-PRC-06/07/08-E NRCC-PRC-10-E NRCC-PRC-11-E

CA Building Energy Efficiency Standards- 2016 Nonresidential Compliance Report Version: NRCC-PRF-01-E-06262019-5583 Report Generated at: 2020-02-04 11:23:37

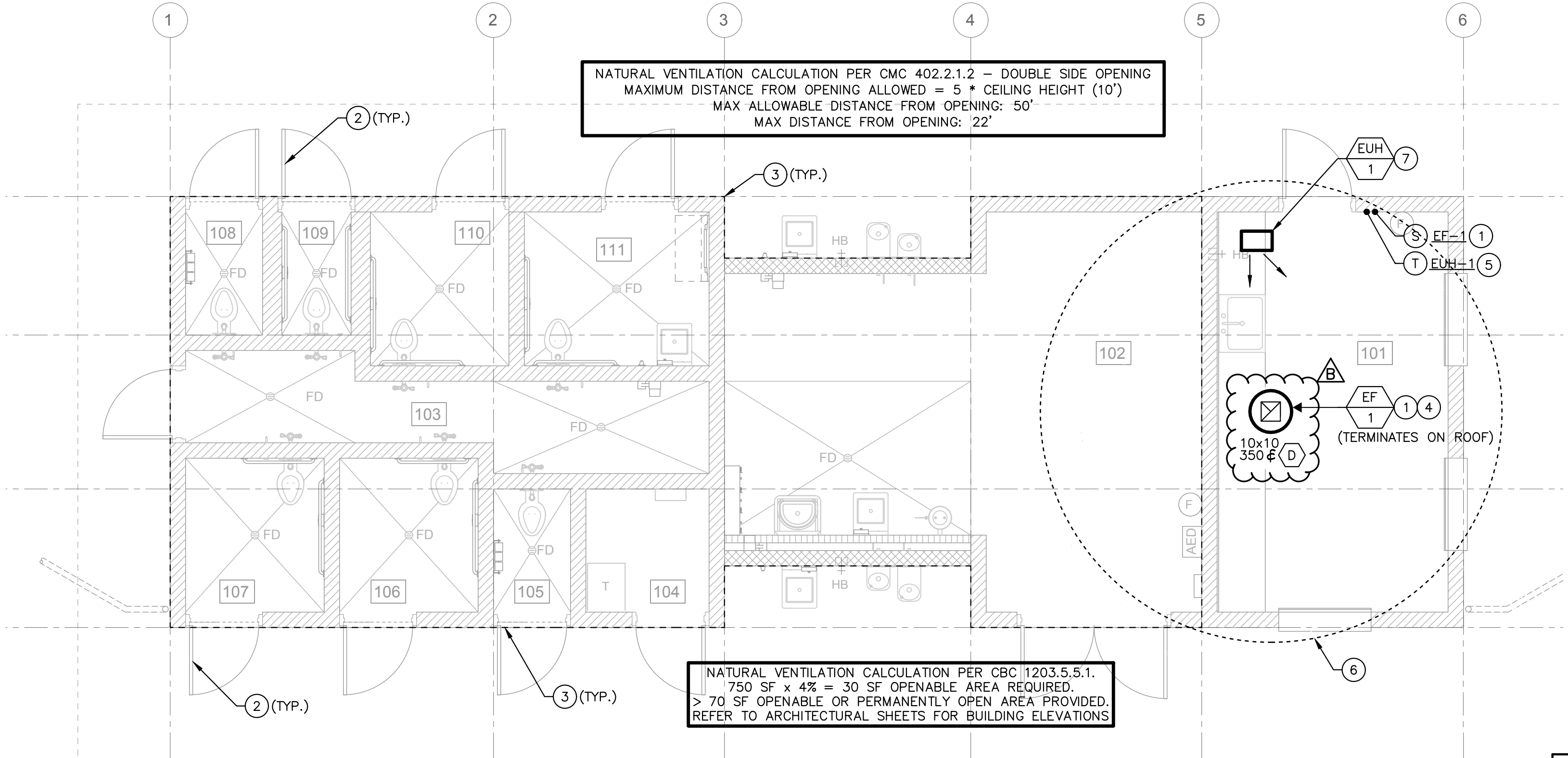

- GENERAL NOTES**
- COORDINATE EXACT LOCATION OF ROOF MOUNTED EQUIPMENT WITH ARCHITECTURAL DRAWINGS.
- KEY NOTES**
- ROOF MOUNTED EXHAUST FAN TO BE CONTROLLED BY WALL SWITCH. SEE DETAILS 1, 2, & 3 ON SHEET M-1. CONFIRM MOUNTING LOCATIONS WITH ARCHITECT PRIOR TO INSTALLATION.
 - RESTROOMS DOORS ARE UNDERCUT, TYPICAL. SEE ARCH DWGS.
 - BUILDING PERIMETER TO HAVE OPEN METAL SCREENING WITH ADEQUATE FREE AREA TO PROVIDE THE REQUIRED VENTILATION TO ALL OCCUPIED SPACES, REFER TO VENT CALCULATIONS ON M-2.
 - 10"x10" RECTANGULAR DUCT UP TO FAN CONNECTION ON ROOF. PROVIDE EXHAUST AIR GRILLE PER AIR DEVICE SCHEDULE.
 - PROGRAMMABLE THERMOSTAT. VERIFY EXACT LOCATION WITH OWNER'S REPRESENTATIVE PRIOR TO START OF WORK. MOUNTING PER DETAIL 1/M-1.
 - MAINTAIN MINIMUM 10'-0" BETWEEN EXHAUST DISCHARGE AND OUTSIDE AIR INTAKES. MAINTAIN MINIMUM 3'-0" BETWEEN EXHAUST DISCHARGE AND BUILDING OPENINGS OR PROPERTY LINES.
 - ELECTRIC UNIT HEATER MOUNTED PER DETAIL 4/M-1. SUPPORT PER MANUFACTURER'S INSTRUCTIONS.

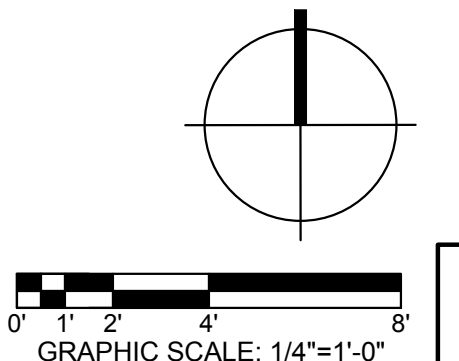

SEE SHEETS E-4 AND E-5 FOR ADDITIONAL TITLE 24 MECHANICAL CALCULATIONS

MECHANICAL FLOOR PLAN

WANGENHEIM NEIGHBORHOOD JOINT USE FACILITY
MECHANICAL FLOOR PLAN AND TITLE 24

RICK ENGINEERING COMPANY
5620 FRIARS ROAD
SAN DIEGO, CA 92110
619-291-0707
(FAX) 619-291-4185
rickengineering.com

T-SQUARED PROFESSIONAL ENGINEERS, INC.
1340 SPECIALTY DR. SUITE E
VISTA, CA 92081
TEL: (760) 560-0100
FAX: (760) 560-0101
#17056
02-05-20
www.tsqeng.com
E-Mail admin@tsqeng.com



SPEC. NO.	CITY OF SAN DIEGO, CALIFORNIA PUBLIC WORKS DEPARTMENT SHEET 100 OF 142 SHEETS	WBS	S-15007
APPROVED:	FOR CITY ENGINEER JASON GRANI PRINT NAME	DATE	10/13/2020 77208
DATE	10/13/2020	DATE	77208
DESCRIPTION	BY	APPROVED	DATE
ORIGINAL	REC		
ADDENDUM B	REC		1/11/2021
CHECKED BY		MEHDI RASHIDPOUR-HARISI PROJECT ENGINEER	
DATE		270-1731 (NAD27)	
DATE		CCS27 COORDINATE	
DATE		1910-6291 (NAD83)	
DATE		CCS83 COORDINATE	
CONTRACTOR	INSPECTOR	DATE STARTED	DATE COMPLETED
			40846-100-D

IDENTIFICATION STAMP
 DIV. OF THE STATE ARCHITECT
 APP. 04-118244 INC.
 REVIEWED FOR
 SS FLS ACS
 DATE: 02.14.2020

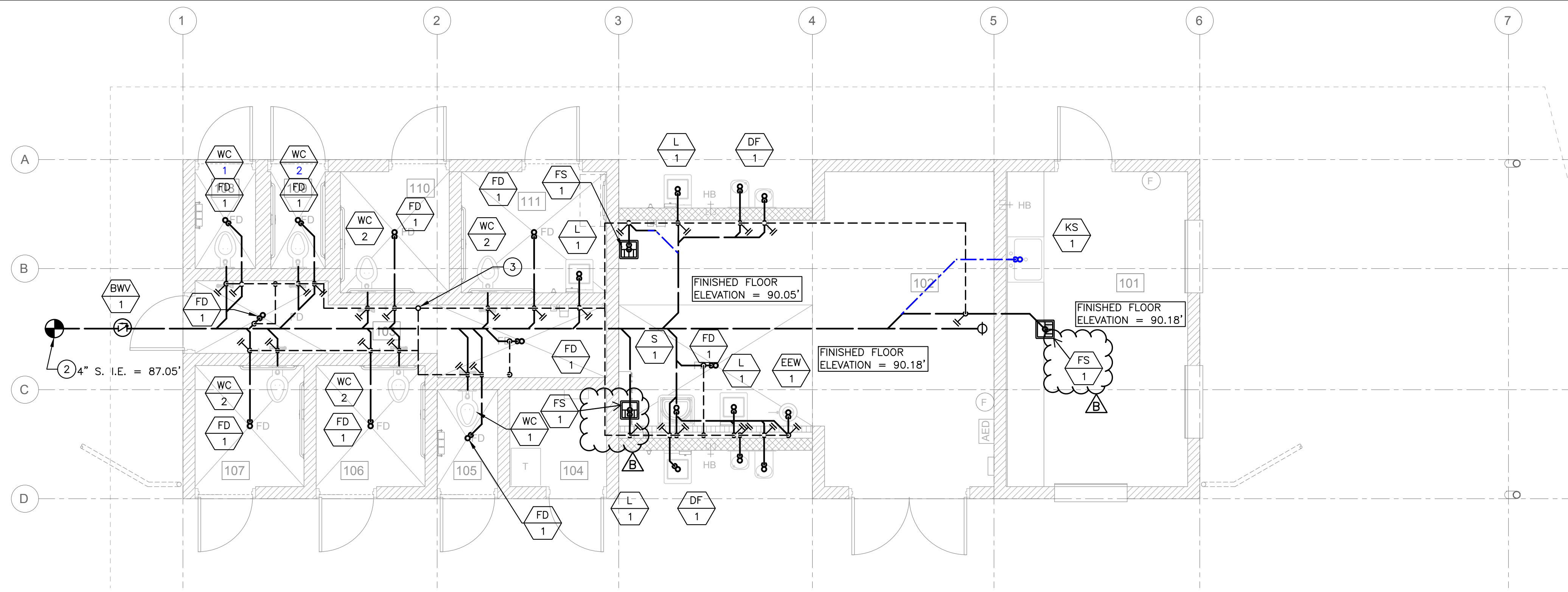

GENERAL NOTES

- A. CONTRACTOR SHALL FIELD VERIFY EXACT LOCATION OF ALL PIPING AND UTILITIES PRIOR TO START OF WORK. IN THE EVENT OF ANY DISCREPANCIES OR POTENTIAL CONFLICTS, NOTIFY THE ARCHITECT AND ENGINEER IN WRITING PRIOR TO START OF WORK.
- B. ALL PIPING LOCATIONS ARE DIAGRAMMATIC. CONTRACTOR SHALL COORDINATE WITH ALL TRADES AND OWNER'S REPRESENTATIVE AND VERIFY EXACT ROUTING PRIOR TO START OF WORK.
- C. VERIFY EXACT SIZE AND LOCATION OF ALL PLUMBING CONNECTIONS TO MECHANICAL EQUIPMENT PRIOR TO START OF WORK. IN NO CASE SHALL THE CONNECTION SIZE BE LARGER THAN THE BRANCH PIPING SIZE.

KEY NOTES

- ① 3" WATER SERVICE P.O.C. SEE CIVIL PLANS FOR CONTINUATION.
- ② 4" S P.O.C. SEE CIVIL PLANS FOR CONTINUATION.
- ③ VENT THROUGH ROOF.
- ④ WATER SERVICE ENTRANCE SHUTOFF VALVE W/ACCESS PANEL.
- ⑤ INSTALL TMV-1 INSIDE BUILDING PROVIDE AND INSTALL ACCESS PANEL.
- ⑥ 1-1/2" IRRIGATION PIPING SEE LANDSCAPE PLANS FOR CONTINUATION.
- ⑦ 1-1/2" WATTS LEAD FREE 909 REDUCED PRESSURE BACKFLOW PREVENTER WITH STRAINER. SERVING 1-1/2" IRRIGATION PIPING.
- ⑧ PROVIDE SOV AND PRV IN YARD BOX.

PLUMBING FLOOR PLAN - SEWER & VENT

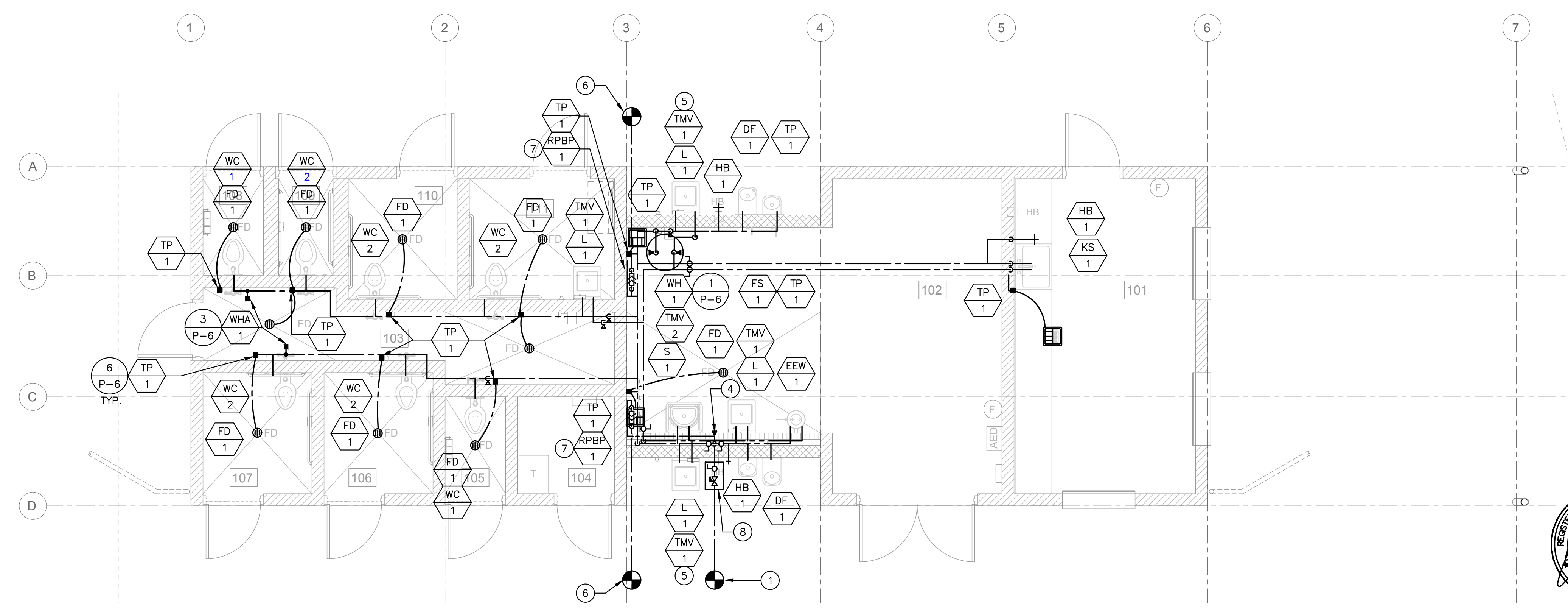

PLUMBING FLOOR PLAN - DOMESTIC WATER

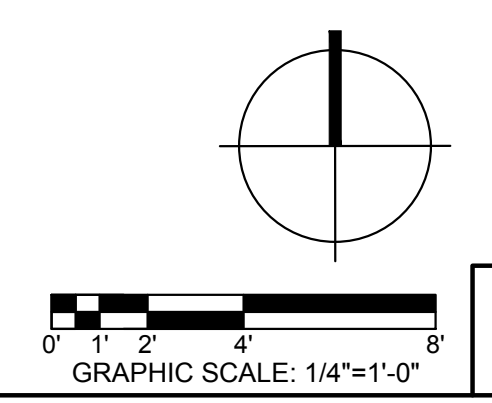

P-4

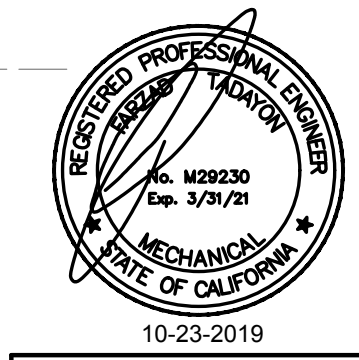

**WANGENHEIM NEIGHBORHOOD
 JOINT USE FACILITY**
**PLUMBING FLOOR PLAN - SEWER &
 VENT AND DOMESTIC WATER**

SPEC. NO.		CITY OF SAN DIEGO, CALIFORNIA PUBLIC WORKS DEPARTMENT SHEET 104 OF 142 SHEETS		WBS	S-15007
APPROVED: FOR CITY ENGINEER JASON GRANI PRINT NAME		10/13/2020 DATE 77208 RCE#		SUBMITTED BY: YOVANNA LEWIS PROJECT MANAGER	
DESCRIPTION		BY	APPROVED	DATE	FILMED
ORIGINAL		REC			
ADDENDUM B		REC		1/11/2021	
CHECKED BY: MEHDI RASHIDPOUR-HARISI PROJECT ENGINEER				270-1731 (NAD27) CCS27 COORDINATE 1910-6291 (NAD83) CCS83 COORDINATE	
CONTRACTOR		DATE STARTED		40846-104-D	
INSPECTOR		DATE COMPLETED			

RICK
 ENGINEERING COMPANY
 5620 FRIARS ROAD
 SAN DIEGO, CA 92110
 619-291-0707
 (FAX) 619-291-4165
 rickengineering.com
 San Diego Riverside - Orange - Sacramento - San Luis Obispo - Phoenix - Tucson - Denver

T-SQUARED
 PROFESSIONAL ENGINEERS, INC.
 1340 SPECIALTY DR.
 SUITE E
 VISTA, CA 92081
 TEL: (760) 560-0100
 FAX: (760) 560-0101
 #17056
 01-20-20
 www.tsqeng.com
 E-Mail admin@tsqeng.com

LIGHTING FIXTURE SCHEDULE-SPORTS LIGHTING								
FIXT DES	SYMBOL	FIXTURE MOUNTING	POLE TYPE	LAMP TYPE	WATTS	VOLTS	MFR/CATALOG	DESCRIPTION
	⊖	POLE		LED 5000K	2975	480	MUSCO LIGHTING	LED SPORT LIGHTING WITH LUMINAIRES AND MOUNTED ON 60' HIGH MAST POLE. SEE NOTE 1, 2 AND 3 BELOW.
A1			NEW POLE					
A2			NEW POLE					
A3			NEW POLE					
A5			NEW POLE					
	⊗	POLE		LED 5000K		480	MUSCO LIGHTING	LED SPORT LIGHTING WITH LUMINAIRES AND MOUNTED ON 70' HIGH MAST POLE. SEE NOTE 1, 2 AND 3 BELOW.
B1			EXIST POLE NEW LOCATION		7150			
B2			EXIST POLE NEW LOCATION		8650			
B3			EXIST POLE NEW LOCATION		6000			
B4			EXIST POLE NEW LOCATION		6000			
B5			EXIST POLE NEW LOCATION		15800			
B6			EXIST POLE NEW LOCATION		6000			
	⊕	POLE		LED 5000K		480	MUSCO LIGHTING	LED SPORT LIGHTING WITH LUMINAIRES AND MOUNTED ON 70' HIGH MAST POLE. SEE NOTE 1, 2 AND 3 BELOW.
S1			EXIST POLE NEW LOCATION		6000			
S2			EXIST POLE NEW LOCATION		6000			
S3			EXIST POLE NEW LOCATION		6000			
S4			EXIST POLE NEW LOCATION		7500			

LIGHTING FIXTURE NOTES:

- PROVIDE SPECIFIED "MUSCO LIGHTING" MANUFACTURER FOR EACH LIGHT FIXTURE/POLE ASSOCIATED WITH BALL FIELD AND SOCCER FIELD LIGHTING. NO SUBSTITUTIONS SHALL BE ALLOWED WITHOUT ARCHITECTS OR CITY OF SAN DIEGO APPROVAL.
- FIXTURES SHALL BE AIMED PER "MUSCO LIGHTING" TO ACHIEVE FOOTCANDLE LEVELS AS RECOMMENDED FOR RECREATIONAL SPORTS LIGHTING LEVELS.
- ELECTRICAL CONTRACTOR TO PROVIDE STRUCTURAL FOOTING CALCULATIONS, DRAWINGS AND COORDINATION FOR LIGHTING FOUNDATION PERMITS.

LIGHTING FIXTURE SCHEDULE							
FIXT DES	SYMBOL	FIXTURE MOUNTING	LAMP TYPE	WATTS	VOLTS	MFR/CATALOG	DESCRIPTION
A	⊖	RECESSED	LED 3500K 3270 LUMENS	30	120	KUTZON VL F 1 1X1 MID 835 UNV 25	LED 1x1 VANDAL RESISTANT LENS FIXTURE AND LISTED FOR WET LOCATION.
B	⊖	SURFACE	LED 3500K 4193 LUMENS	30	120	KUTZON VL R 5 1X4 LEDR 835 UNV 25 PXW (30WATTS)	LED 1'X4' VANDAL RESISTANT LENS FIXTURE.
C	⊖	SURFACE	LED 3500K 2000 LUMENS	32	120	LITHONIA LIGHTING ZL2N L48 2000LM MDD MVOLT 35K 80CRI WH	LED 4' ENCLOSED AND GASKETED LENS FIXTURE SUITABLE FOR WET LOCATION.
D	⊖	RECESSED	LED 3500K 2300 LUMENS	20	120	KUTZON VL F 1 1X1 LO 835 UNV 25	LED 1x1 VANDAL RESISTANT LENS FIXTURE AND LISTED FOR WET LOCATION.
J	☀	POLE POST TOP	LED 4000K	66	120	NLS LIGHTING HRZ1-T3-64L-35-40K-UNV-PT-BRZ-DT-FSP211 FSP20	LED POST TOP AND POLE FIXTURE WITH MOTION SENSOR OPTION.
K	⊖	POLE	LED 4000K	168	277	NLS LIGHTING NV2 T4 80L 7 40K UNV DP6 BRZ RPA4	LED POLE MOUNTED FIXTURE WITH SINGLE LUMINAIRE, BRONZE FINISH.

LIGHTING FIXTURE NOTES:

- PROVIDE SPECIFIED LIGHTING MANUFACTURER FOR EACH LIGHT FIXTURE. ANY SUBSTITUTIONS SHALL MEET OR EXCEED THE SPECIFICATIONS OF THE LISTED MANUFACTURERS CATALOG NUMBER.
- SUPPORT DOWNLIGHT FIXTURES (RECESSED) FROM STRUCTURE ABOVE WITH (2) CEILING WIRES AND WITH EMT CHANNEL LAID ACROSS CEILING SUPPORT CHANNELS.
- REFER TO ARCHITECTURAL REFLECTED CEILING PLANS FOR EXACT LOCATION & QUANTITY OF LIGHT FIXTURES. ALL LIGHT FIXTURES HEIGHTS TO BE COORDINATED BY ARCHITECT.
- ELECTRICAL CONTRACTOR TO PROVIDE STRUCTURAL FOOTING CALCULATIONS, DRAWINGS FROM STRUCTURAL ENGINEER AND COORDINATION FOR LIGHTING FOUNDATION PERMITS.
- OUTDOOR LIGHTING FIXTURES THAT ARE USED TO ILLUMINATE A PREMISES, ARCHITECTURAL FEATURE OR LANDSCAPE FEATURE ON PRIVATE PROPERTY SHALL BE DIRECTED, SHIELDED, OR LOCATED IN SUCH A MANNER THAT THE LIGHT SOURCE IS NOT VISIBLE OFFSITE, TO MINIMIZE LIGHT EMISSION ABOVE THE HORIZONTAL PLANE AND SO THAT LIGHT DOES NOT FALL ONTO SURROUNDING PROPERTIES OR CREATE GLARE HAZARDS WITH PUBLIC RIGHTS-OF-WAY.
- ALL EXTERIOR LIGHTING INSTALLATIONS AND LAMP TYPE SHALL COMPLY WITH CITY OF SAN DIEGO OUTDOOR LIGHTING REGULATIONS 142.0740

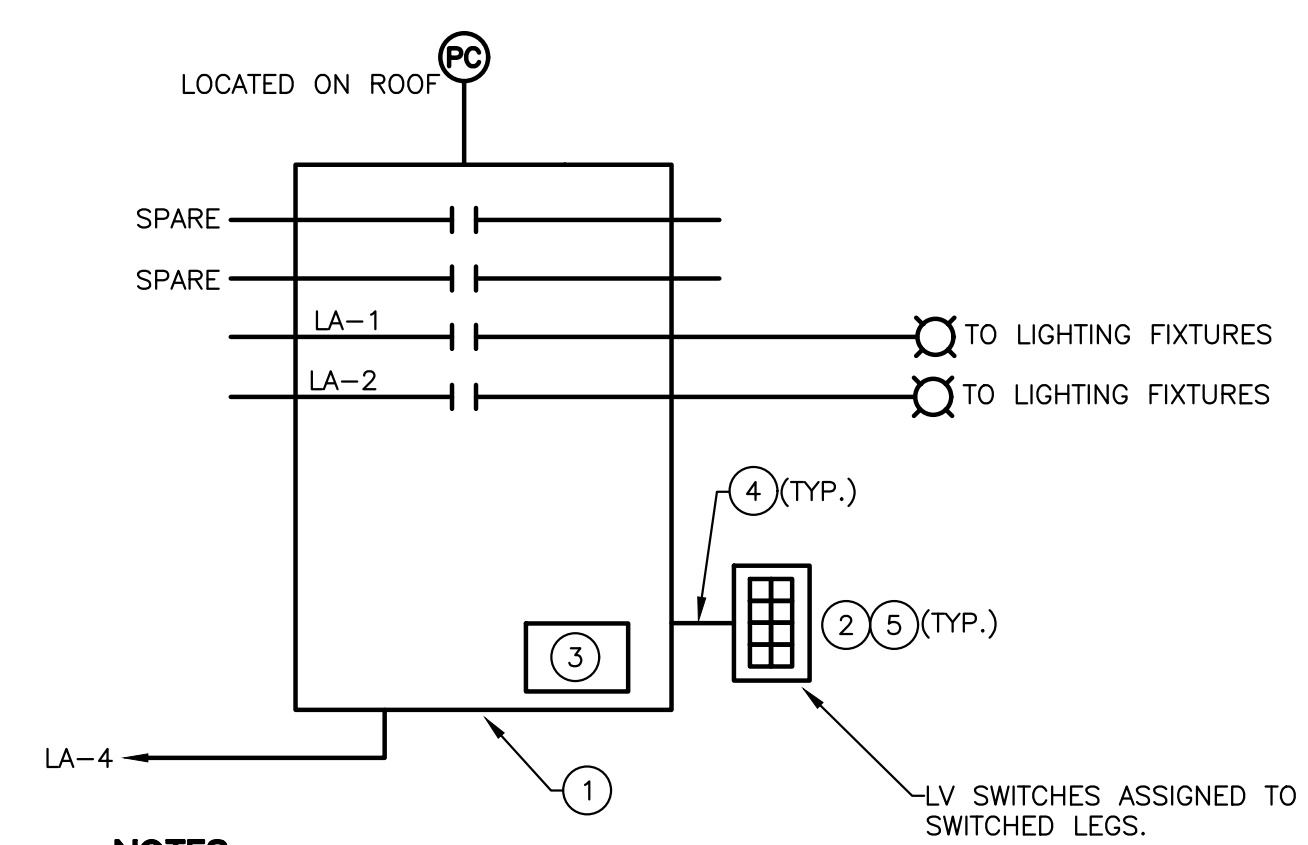

- NOTES:**
- LIGHTING CONTROL PANEL "LCPD" SHALL BE ACUITY BRANDS "nLIGHT" GATEWAY SERIES 2 CLOCK AND NETWORK INTERFACE CONTROLLER.
 - PROVIDE "nLIGHT" #nPDM 4PDX WH LOW VOLTAGE WALL SWITCHES AS SHOWN ON PLANS.
 - ASTRONOMICAL TIME CLOCK.
 - CAT5 CABLE IN 1/2" C PER MANUFACTURER'S REQUIREMENTS.
 - PROGRAM SUCH THAT SWITCHES PERFORM FUNCTIONS FROM 8:00AM TO 2:00AM AND BY-PASS FUNCTION FROM 2:00AM TO 8:00AM WITH 0-2HR TIMER SWITCH. (VERIFY SCHEDULE WITH CITY OF SAN DIEGO MAINTENANCE ENGINEER)

1 LCP WIRING DIAGRAM
SCALE: NONE

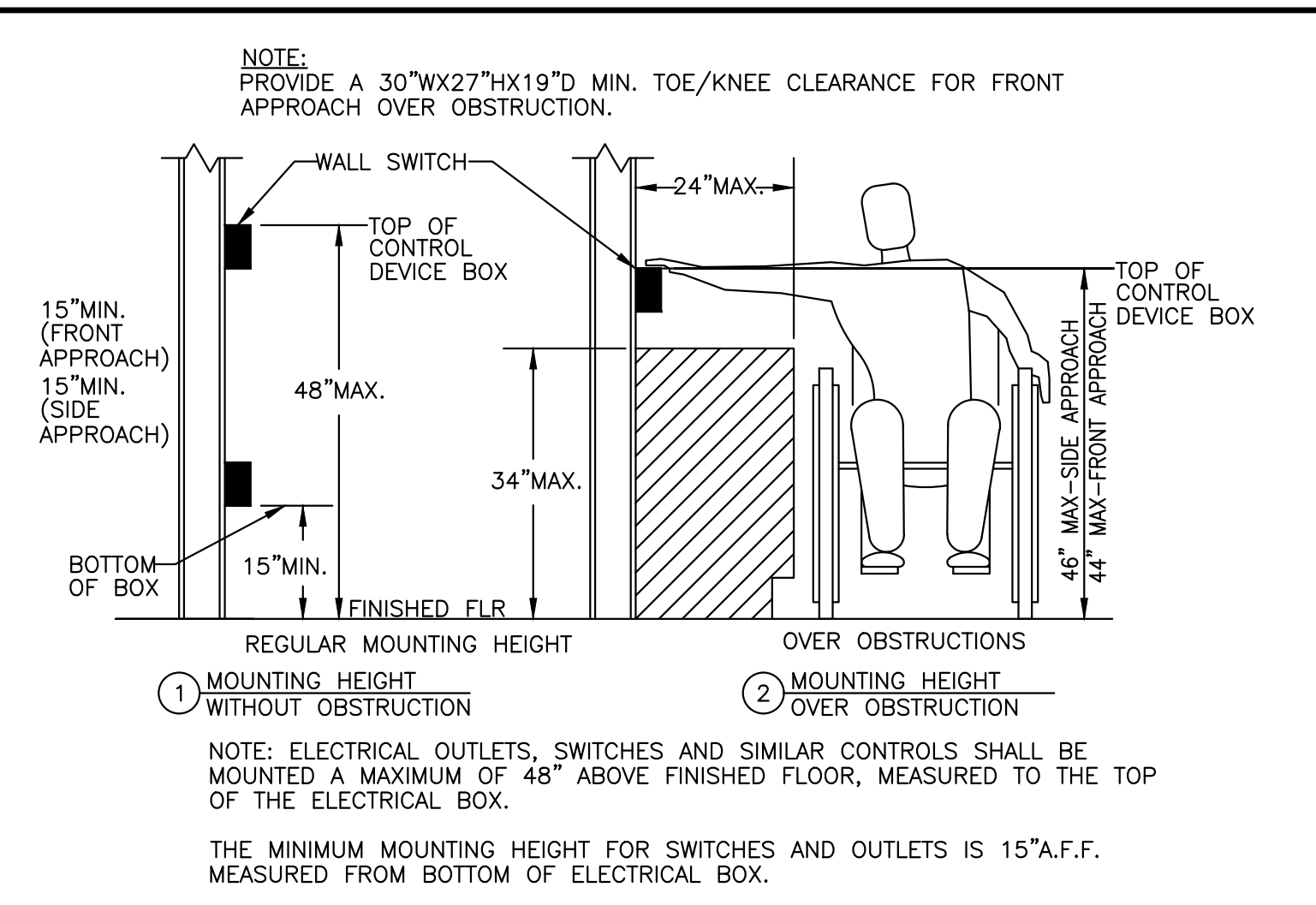
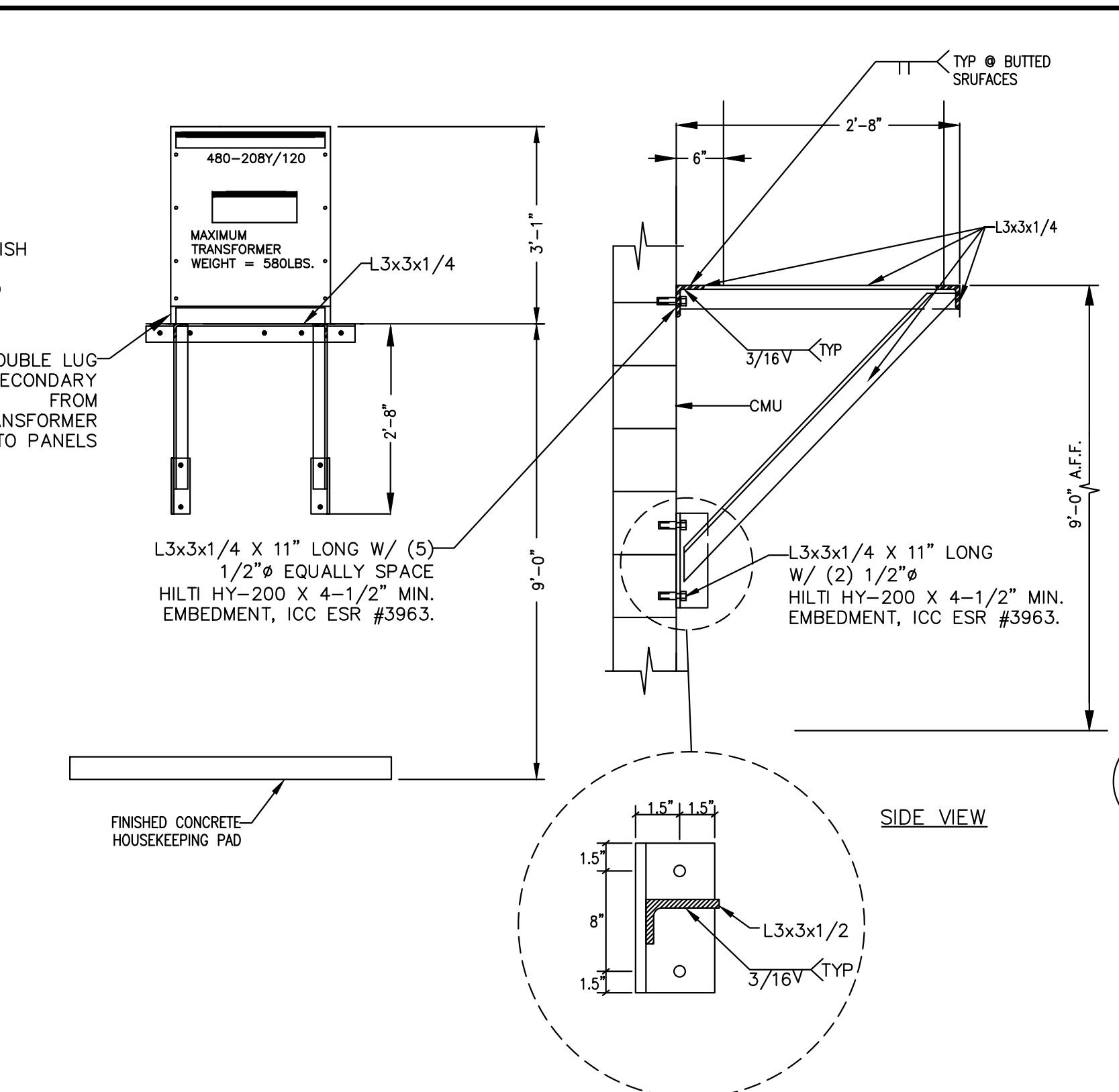
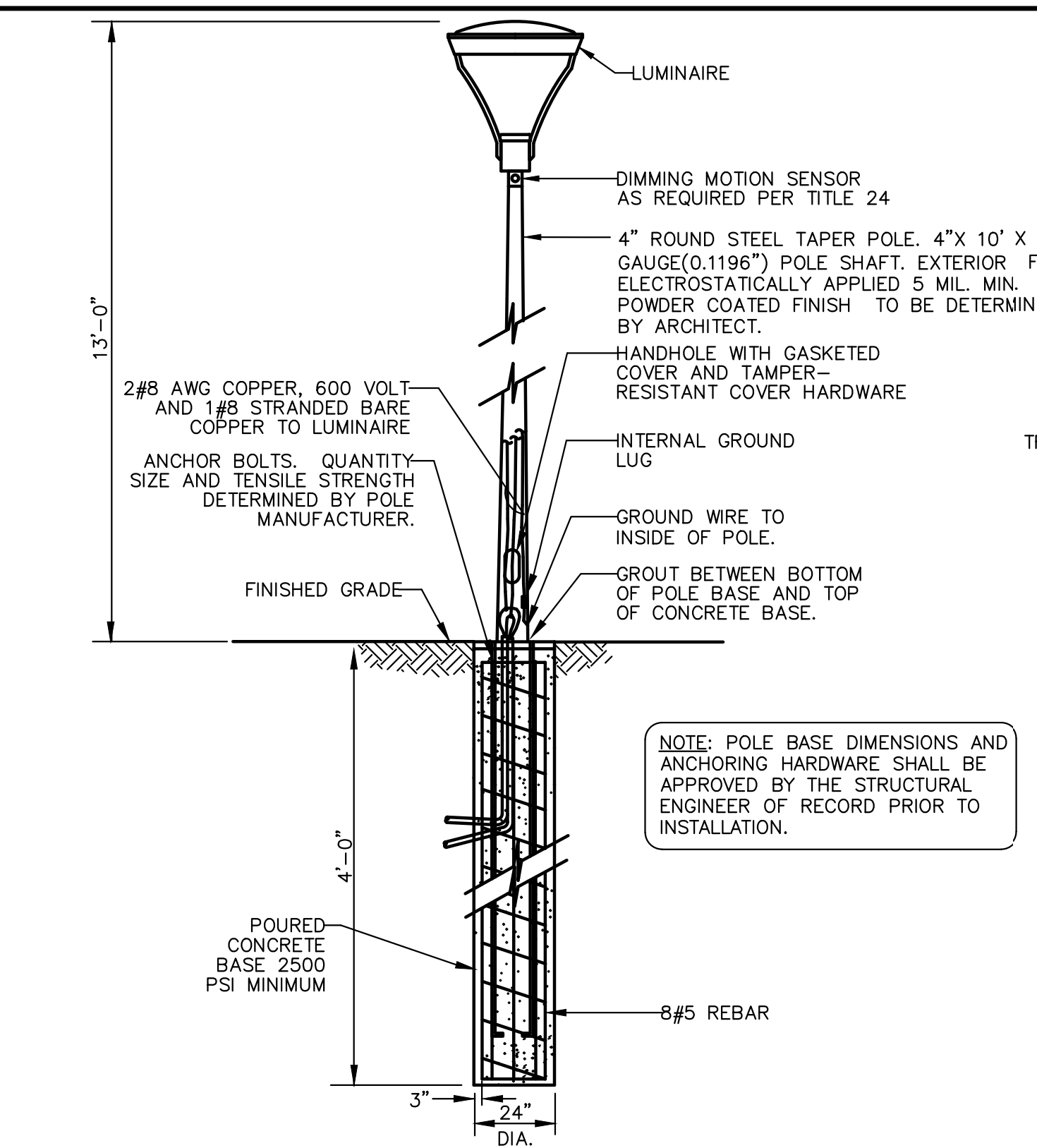
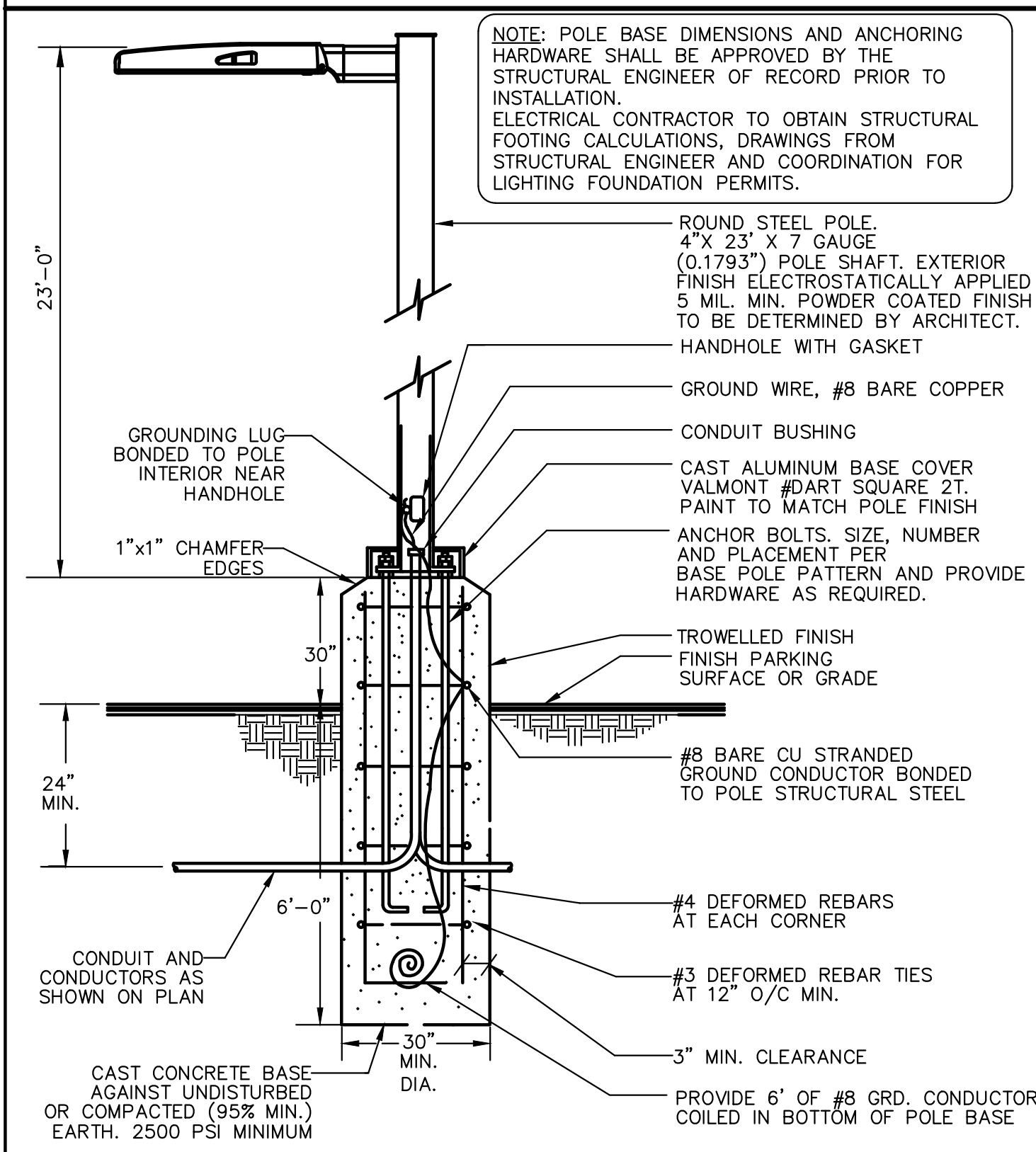

RICK ENGINEERING COMPANY
5620 FRIARS ROAD
SAN DIEGO, CA 92110
619-291-0707
(FAX) 619-291-4165
San Diego
Riverside - Orange - Sacramento - San Luis Obispo - Phoenix - Tucson - Denver

J-17721
#17056
12-09-19
www.rickeng.com
E-Mail admin@rickeng.com

T-SQUARED PROFESSIONAL ENGINEERS, INC.
1340 SPECIALTY DR.
SUITE E
VISTA, CA 92081
TEL: (760) 560-0100
FAX: (760) 560-0101

GZ MD JC GZ

WANGENHEIM NEIGHBORHOOD JOINT USE FACILITY
ELECTRICAL SCHEDULES AND DETAILS

CITY OF SAN DIEGO, CALIFORNIA
PUBLIC WORKS DEPARTMENT
SHEET 108 OF 142 SHEETS

APPROVED: *[Signature]* 10/13/2020
FOR CITY ENGINEER: JASON GRANI
PRINT NAME: JASON GRANI RCE# 77208

DATE: 10/13/2020
DATE: 7/20/2018

PROJECT MANAGER: YOVANNA LEWIS
PROJECT ENGINEER: MEHDI RASHIDPOUR-HARISI

DESCRIPTION BY APPROVED DATE FILMED
ORIGINAL REC 1/11/2021
ADDENDUM B REC

270-1731 (NAD27)
CCS27 COORDINATE
1910-6291 (NAD83)
CCS83 COORDINATE

CONTRACTOR: _____ DATE STARTED: _____
INSPECTOR: _____ DATE COMPLETED: _____

40846-108-D

IDENTIFICATION STAMP
 DIV. OF THE STATE ARCHITECT
 APP. 04-118244 INC:
 REVIEWED FOR
 SS FLS ACS
 DATE: 02.14.2020

GENERAL NOTES

A. CONTRACTOR SHALL FIELD VERIFY EXISTING CONDITIONS AND COORDINATE WITH ALL OTHER TRADES. IN CASE OF DISCREPANCIES OR ANY POTENTIAL CONFLICTS, INFORM THE ARCHITECT AND ENGINEER IN WRITING PRIOR TO START OF WORK.

KEY NOTES

- ① EXISTING SDG&E HIGH VOLTAGE SWITCH, SDG&E # D155434-438. PROTECT IN PLACE.
- ② SEE SPORTS LIGHTING PHOTOMETRICS ON SHEET E-17.

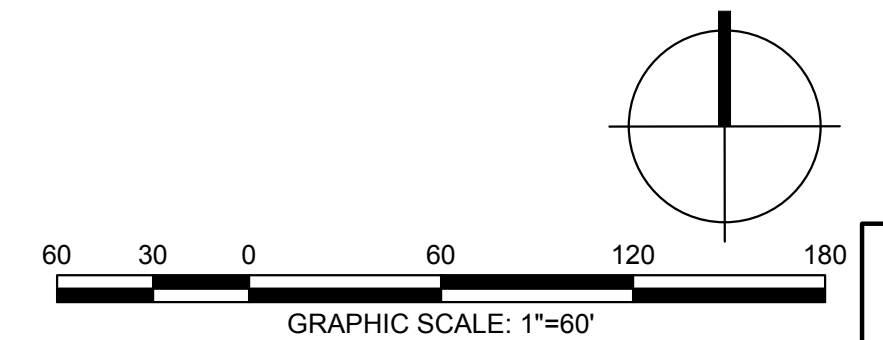
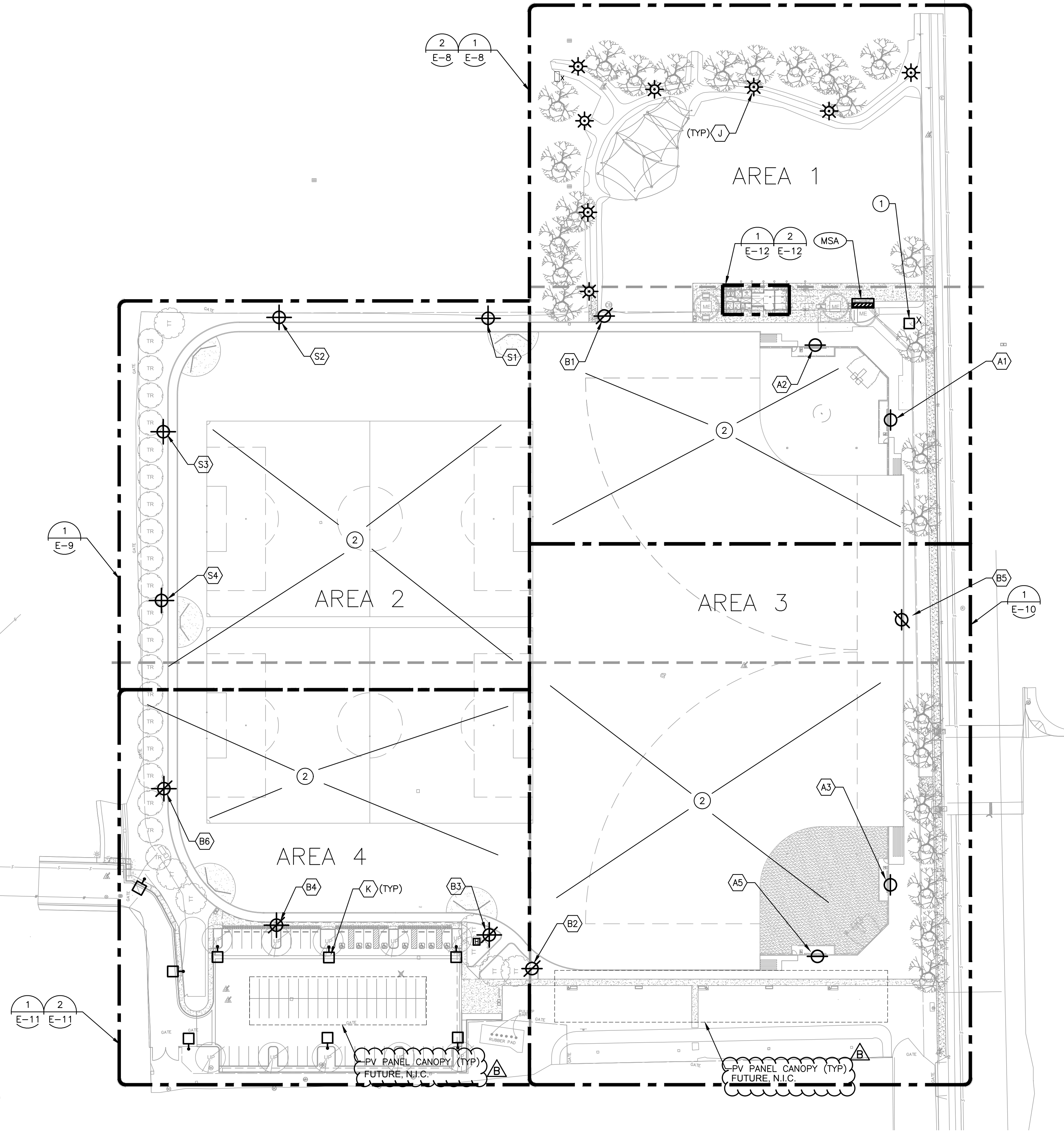

E-7

ELECTRICAL SITE PLAN OVERALL

**WANGENHEIM NEIGHBORHOOD
 JOINT USE FACILITY
 ELECTRICAL SITE PLAN OVERALL**



SPEC. NO.		CITY OF SAN DIEGO, CALIFORNIA PUBLIC WORKS DEPARTMENT SHEET 113 OF 142 SHEETS		WBS	S-15007
APPROVED: <i>[Signature]</i>		10/13/2020 DATE		SUBMITTED BY: YOVANNA LEWIS PROJECT MANAGER	
FOR CITY ENGINEER JASON GRANI		77208 RCE#		CHECKED BY: MEHDI RASHIDPOUR-HARISI PROJECT ENGINEER	
DESCRIPTION	BY	APPROVED	DATE	FILMED	
ORIGINAL	REC				270-1731 (NAD27)
ADDENDUM B	REC	<i>[Signature]</i>	1/11/2021		CCS27 COORDINATE
					1910-6291 (NAD83)
					CCS83 COORDINATE
CONTRACTOR		DATE STARTED			40846-113-D
INSPECTOR		DATE COMPLETED			

RICK ENGINEERING COMPANY
 5620 FRIARS ROAD
 SAN DIEGO, CA 92110
 619-291-0707
 (FAX) 619-291-4165
 rickengineering.com
 San Diego Riverside - Orange - Sacramento - San Luis Obispo - Phoenix - Tucson - Denver

T-SQUARED
 PROFESSIONAL ENGINEERS, INC.
 1340 SPECIALTY DR.
 SUITE E
 VISTA, CA 92081
 TEL: (760) 560-0100
 FAX: (760) 560-0101
 #17056
 12-09-19
 www.tsqeng.com
 E-Mail admin@tsqeng.com

ADDENDUM B

IDENTIFICATION STAMP
 DIV. OF THE STATE ARCHITECT
 APP. 04-118244 INC.
 REVIEWED FOR
 SS FLS ACS
 DATE: 02.14.2020

GENERAL NOTES

- A. CONTRACTOR SHALL FIELD VERIFY EXISTING CONDITIONS AND COORDINATE WITH ALL OTHER TRADES. IN CASE OF DISCREPANCIES OR ANY POTENTIAL CONFLICTS, INFORM THE ARCHITECT AND ENGINEER IN WRITING PRIOR TO START OF WORK.

KEY NOTES

- 1 EXISTING IRRIGATION BOOSTER PUMP AND CIRCUIT BREAKER TO REMAIN AND OPERATIONAL DURING CONSTRUCTION. CONTRACTOR SHALL TRACE EXISTING POWER CONNECTION AND PROVIDE AS-BUILTS FOR REFERENCE.
- 2 EXISTING 70' POLE TO BE REUSED IN NEW LOCATION.
- 3 EXISTING METER/PEDESTAL FOR EXISTING BOOSTER PUMP AND IRRIGATION CONTROLLER TO BE OPERATIONAL DURING CONSTRUCTION.
- 4 EXISTING ELECTRICAL UTILITY BOX TO BE REMOVED.
- 5 INTERCEPT EXISTING BOOSTER PUMP UTILITY CIRCUIT WITH MATCHING CONDUIT AND WIRES AND EXTEND TO NEW HANDHOLE. VERIFY EXISTING CONDITIONS.
- 6 HANDHOLES FOR FUTURE PV PANEL CANOPY. PROVIDE (2) 2" CONDUIT ONLY (1) FOR POWER AND (1) DATA.
- 7 STUB OUT TO ADJACENT TO SWITCHBOARD "MSA". SEE SHEET E-8 FOR LOCATION.
- 8 IRRIGATION BOOSTER PUMP. CONFIRM EXACT LOCATION WITH LANDSCAPE ARCHITECT.

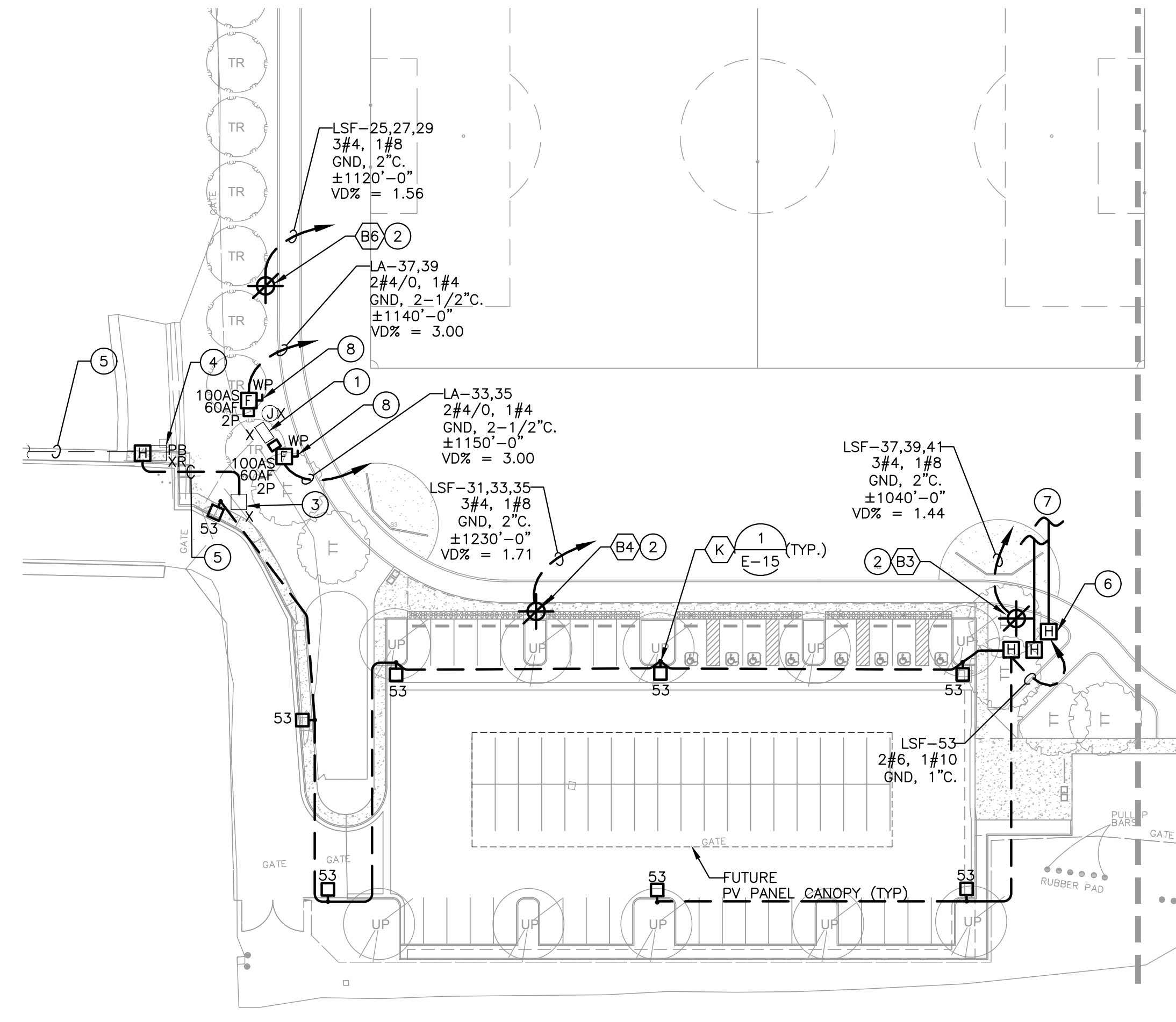
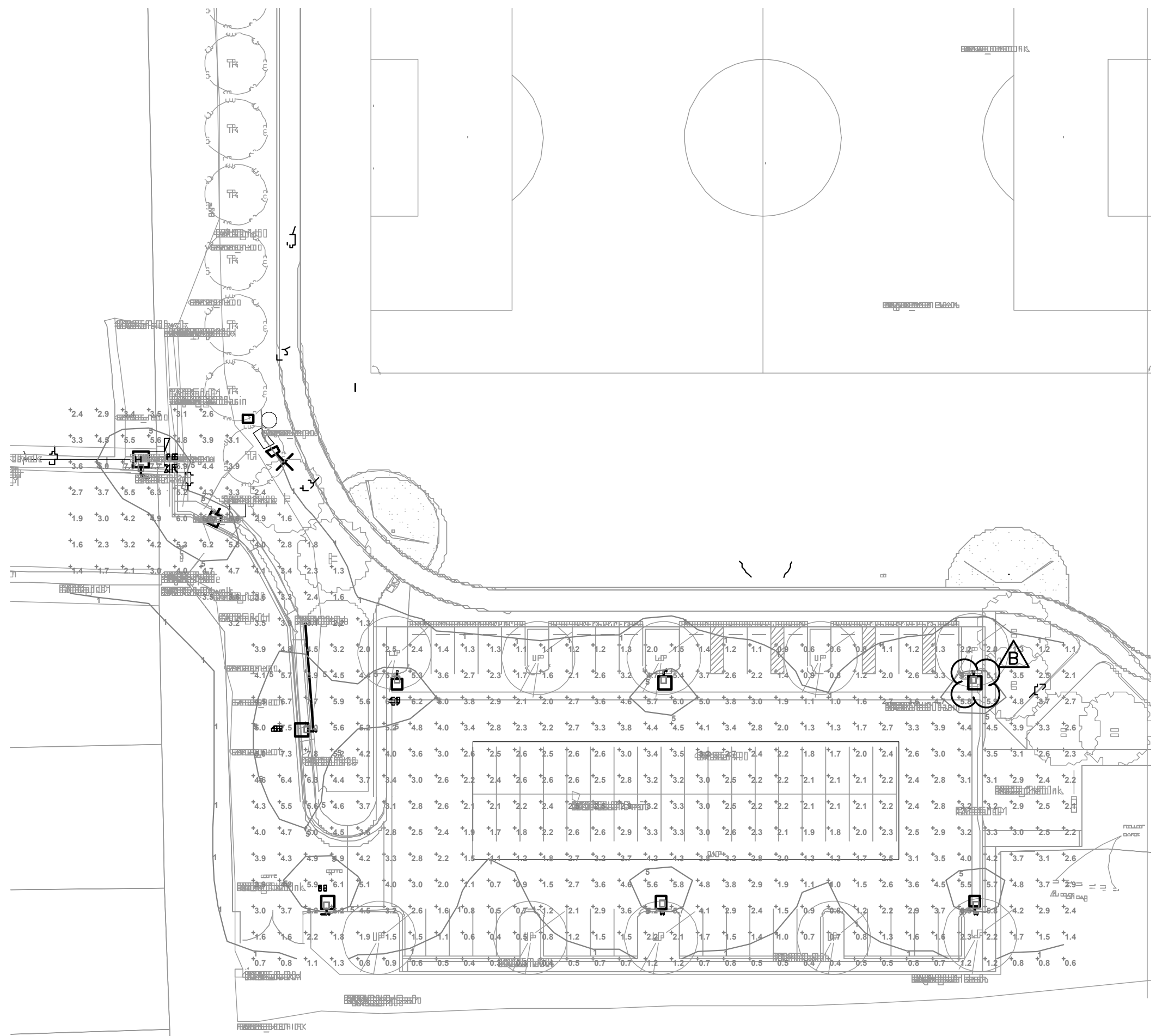

Statistics						
Description	Symbol	Avg	Max	Min	Max/Min	Avg/Min
Calc Zone #1	+	2.9 fc	9.0 fc	0.3 fc	30.0:1	9.7:1

2 ELECTRICAL SITE PLAN - AREA 4 PHOTOMETRIC

1 ELECTRICAL SITE PLAN - AREA 4

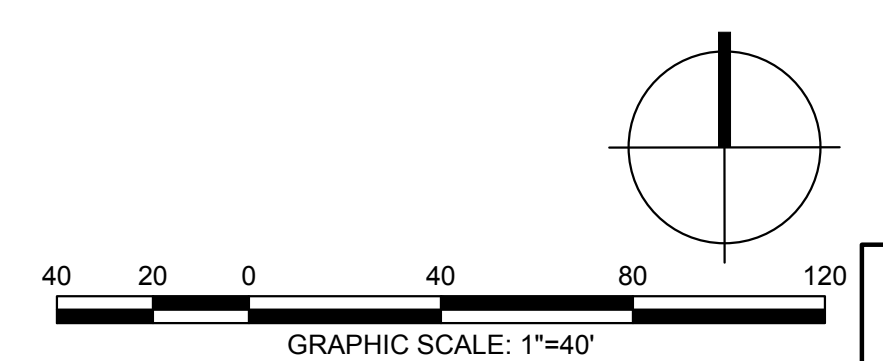

E-11

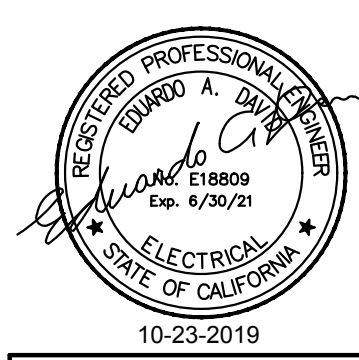

**WANGENHEIM NEIGHBORHOOD
 JOINT USE FACILITY**
ELECTRICAL SITE PLAN - AREA 4

SPEC. NO.	CITY OF SAN DIEGO, CALIFORNIA PUBLIC WORKS DEPARTMENT SHEET 117 OF 142 SHEETS	WBS S-15007
APPROVED FOR CITY ENGINEER JASON GRANI PRINT NAME	10/13/2020 DATE 77208 RCE#	SUBMITTED BY YOVANNA LEWIS PROJECT MANAGER
DESCRIPTION BY APPROVED DATE FILMED	ORIGINAL REC	CHECKED BY MEHDI RASHIDPOUR-HARISI PROJECT ENGINEER
ADDDENDUM B REC	1/11/2021	270-1731 (NAD27) CCS27 COORDINATE 1910-6291 (NAD83) CCS83 COORDINATE
CONTRACTOR INSPECTOR	DATE STARTED DATE COMPLETED	40846-117-D

RICK ENGINEERING COMPANY
 5620 FRIARS ROAD
 SAN DIEGO, CA 92110
 619-291-0707
 (FAX) 619-291-4185
 San Diego
 J-17721
 rickeengineering.com

T-SQUARED PROFESSIONAL ENGINEERS, INC.
 1340 SPECIALTY DR.
 SUITE E
 VISTA, CA 92081
 TEL: (760) 560-0100
 FAX: (760) 560-0101
 #17056
 12-09-19
 www.tsqeng.com
 E-Mail admin@tsqeng.com

IDENTIFICATION STAMP
 DIV. OF THE STATE ARCHITECT
 APP. 04-118244 INC.
 REVIEWED FOR
 SS FLS ACS
 DATE: 02.14.2020

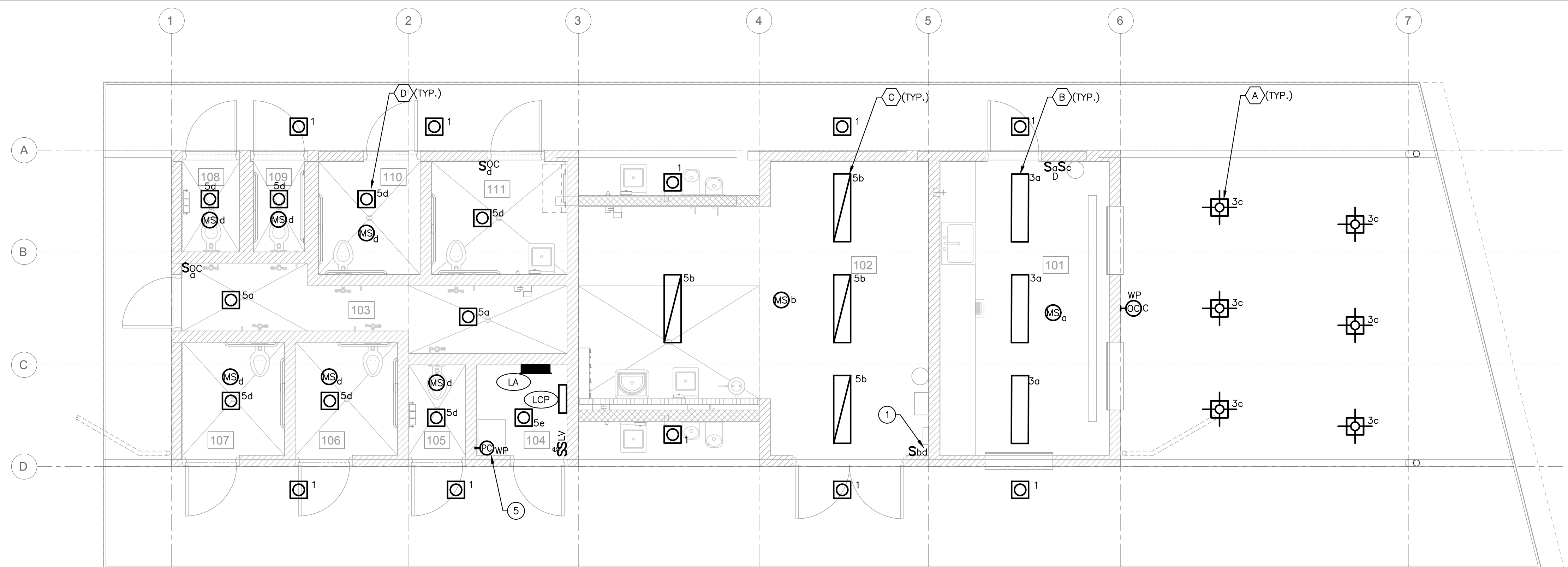

GENERAL NOTES

- A. CONTRACTOR SHALL FIELD VERIFY EXISTING CONDITIONS AND COORDINATE WITH ALL OTHER TRADES. IN CASE OF DISCREPANCIES OR ANY POTENTIAL CONFLICTS, INFORM THE ARCHITECT AND ENGINEER IN WRITING PRIOR TO START OF WORK.
- B. CONTRACTOR SHALL VERIFY EXACT QUANTITIES, LOCATIONS AND HEIGHTS OF ALL OUTLETS WITH TENANT AND ARCHITECT PRIOR TO START OF WORK.
- C. CONTRACTOR SHALL FIELD VERIFY AND COORDINATE WITH MECHANICAL DRAWINGS FOR EXACT EQUIPMENT LOCATIONS AND REQUIREMENTS PRIOR TO START OF WORK.
- D. MECHANICAL EQUIPMENT FUSE SIZE RATINGS PER EQUIPMENT MANUFACTURER'S RECOMMENDATIONS.
- E. ALL MECHANICAL EQUIPMENT FUSIBLE DISCONNECTS AND MOTOR RATED SWITCHES EXPOSED TO WEATHER SHALL BE WEATHERPROOF RATED.
- C. ALL LIGHTING TO BE CONNECTED TO PANEL 'LA'. CIRCUIT NUMBER(S) AS SHOWN.
- D. ALL FIXTURES PROVIDED WITH EGRESS LIGHTING BATTERY PACK BACK-UP SHALL BE FED FROM UNSWITCHED CIRCUIT SERVING LIGHTING IN SAME AREA PER NEC ARTICLE 700.12(F). EMERGENCY BATTERY PACK SHALL BE ACTIVATED ONLY UPON NORMAL POWER FAILURE.

KEY NOTES

- ① OVERRIDE SWITCH FOR THE RESTROOM LIGHTS.
- ② PROVIDE 2" C. FOR TELEPHONE/DATA. CONTRACTOR TO FIELD VERIFY POINT OF CONNECTION.
- ③ PROVIDE 2" W X 8" H X 3/4" THICK PLYWOOD BACKBOARD FOR TELEPHONE EQUIPMENT AND 1#6 CU. GND. IN 3/4" C TO MAIN SERVICE GROUND.
- ④ J-BOX FOR IRRIGATION CONTROLLERS. VERIFY LOCATION AND REQUIREMENTS WITH LANDSCAPE ARCHITECT PRIOR TO INSTALLATION. MOUNT AT +60".
- ⑤ PHOTOCELL MOUNTED ON TOP OF ROOF.
- ⑥ PROVIDE LOCKABLE TYPE RECEPTACLE.

1 LIGHTING FLOOR PLAN

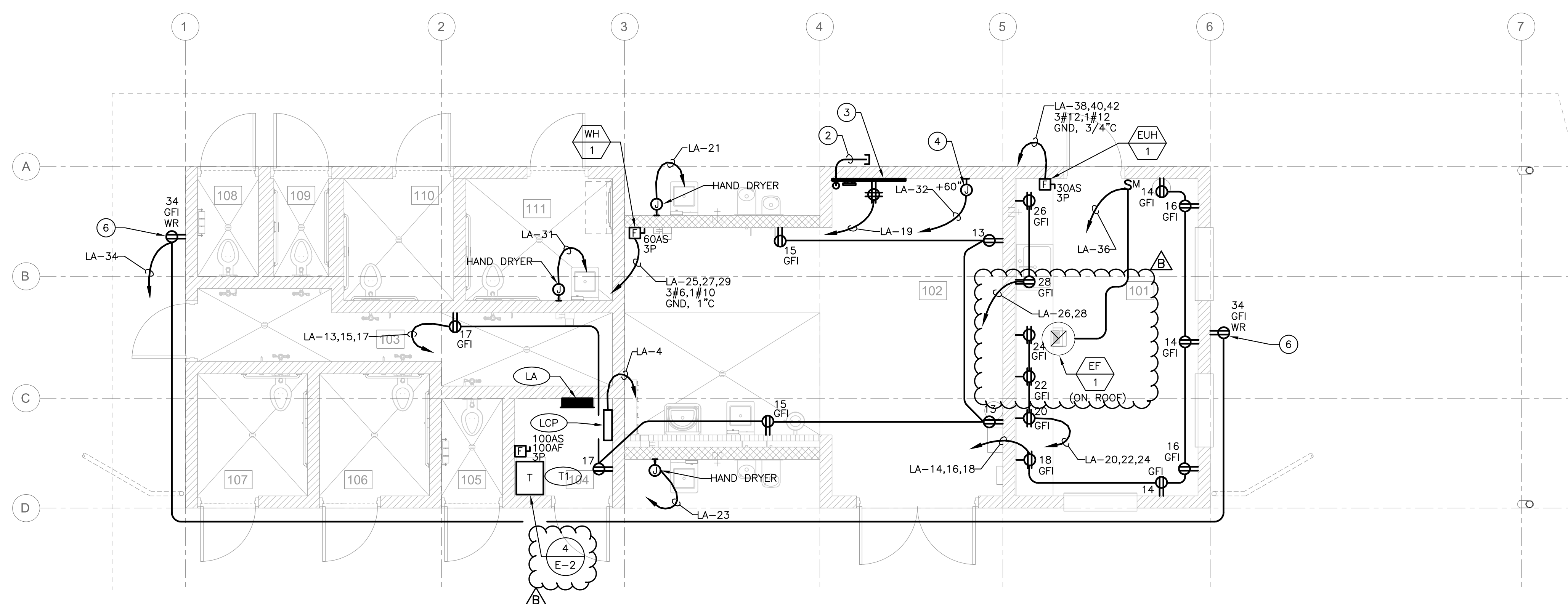

2 POWER FLOOR PLAN

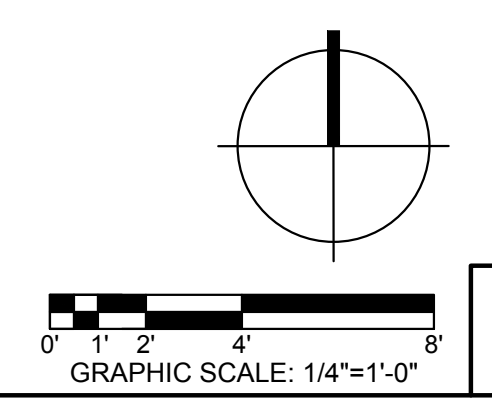

E-12

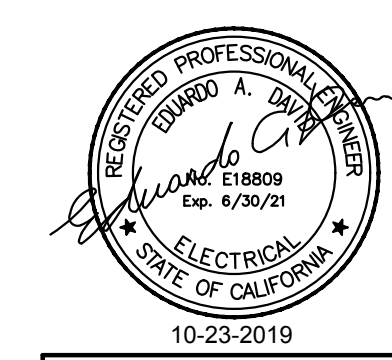

WANGENHEIM NEIGHBORHOOD JOINT USE FACILITY
LIGHTING & POWER FLOOR PLAN

SPEC. NO.		CITY OF SAN DIEGO, CALIFORNIA PUBLIC WORKS DEPARTMENT SHEET 118 OF 142 SHEETS		WBS S-I5007	
APPROVED: <i>J. Grani</i> FOR CITY ENGINEER JASON GRANI PRINT NAME		DATE 10/13/2020 77208 RCE#		SUBMITTED BY: YOVANNA LEWIS PROJECT MANAGER	
DESCRIPTION		BY	APPROVED	DATE	FILMED
ORIGINAL	REC				
ADDENDUM B	REC	<i>J. Grani</i>		1/11/2021	
CHECKED BY: MEHDI RASHIDPOUR-HARISI PROJECT ENGINEER					270-1731 (NAD27)
					1910-6291 (NAD83)
					CCS83 COORDINATE
CONTRACTOR		DATE STARTED		40846-118-D	
INSPECTOR		DATE COMPLETED			

RICK ENGINEERING COMPANY
 5620 FRIARS ROAD
 SAN DIEGO, CA 92110
 619-291-0707
 (FAX) 619-291-4165
 rickengineering.com
 San Diego Riverside - Orange - Sacramento - San Luis Obispo - Phoenix - Tucson - Denver

T-SQUARED
 PROFESSIONAL ENGINEERS, INC.
 1340 SPECIALTY DR.
 SUITE E
 VISTA, CA 92081
 TEL: (760) 560-0100
 FAX: (760) 560-0101
 #17056
 12-09-19
 www.tsqeng.com
 E-Mail admin@tsqeng.com

IDENTIFICATION STAMP
 DIV. OF THE STATE ARCHITECT
 APP. 04-118244 INC.
 REVIEWED FOR
 SS FLS ACS
 DATE: 02.14.2020

EQUIPMENT LIST FOR AREAS SHOWN									
QTY	Pole			Luminaires					
	LOCATION	SIZE	GRADE ELEVATION	MOUNTING HEIGHT	LUMINAIRE TYPE	QTY / POLE	THIS GRID	OTHER GRIDS	
2	A1-A2	60'		15.5'	TLC-BT-575	1	1	0	
				60'	TLC-LED-1200	2	2	0	
1	B1	70'		15.5'	TLC-BT-575	2	2	0	
				70'	TLC-LED-1500	4	4	0	
1	B5	70'		15.5'	TLC-BT-575	4	2	2	
				70'	TLC-LED-1500	9	4	5	
4	TOTALS					25	18	7	

Wangenheim School Park San Diego, CA

GRID SUMMARY	
Name:	Field #1
Size:	250'/250'/250' - basepath 60'
Spacing:	20.0' x 20.0'
Height:	3.0' above grade

ILLUMINATION SUMMARY		
MAINTAINED HORIZONTAL FOOT CANDLES		
	Infield	Outfield
Scan Average:	39.5	21.4
Maximum:	61.0	43.0
Minimum:	18.7	6.6
Avg / Min:	2.11	3.25
Max / Min:	3.26	6.53
UG (adjacent pts):	1.97	2.12
CU:	0.67	
No. of Points:	25	119

LUMINAIRE INFORMATION			
Color / CRI: 5700K - 75 CRI			
Luminaire Output: 160,000 / 52,000 / 136,000 lumens			
No. of Luminaires: 18			
Total Load: 19.57 kW			
Luminaire Type	L90 hrs	L80 hrs	L70 hrs
TLC-LED-1500	>81,000	>81,000	>81,000
TLC-BT-575	>81,000	>81,000	>81,000
TLC-LED-1200	>81,000	>81,000	>81,000

Reported per TM-21-11. See luminaire datasheet for details.

Guaranteed Performance: The ILLUMINATION described above is guaranteed per your Musco Warranty document and includes a 0.95 dirt depreciation factor.

Field Measurements: Individual field measurements may vary from computer-calculated predictions and should be taken in accordance with IESNA RP-6-15.

Electrical System Requirements: Refer to Amperage Draw Chart and/or the "Musco Control System Summary" for electrical sizing.

Installation Requirements: Results assume ± 3% nominal voltage at line side of the driver and structures located within 3 feet (1m) of design locations.

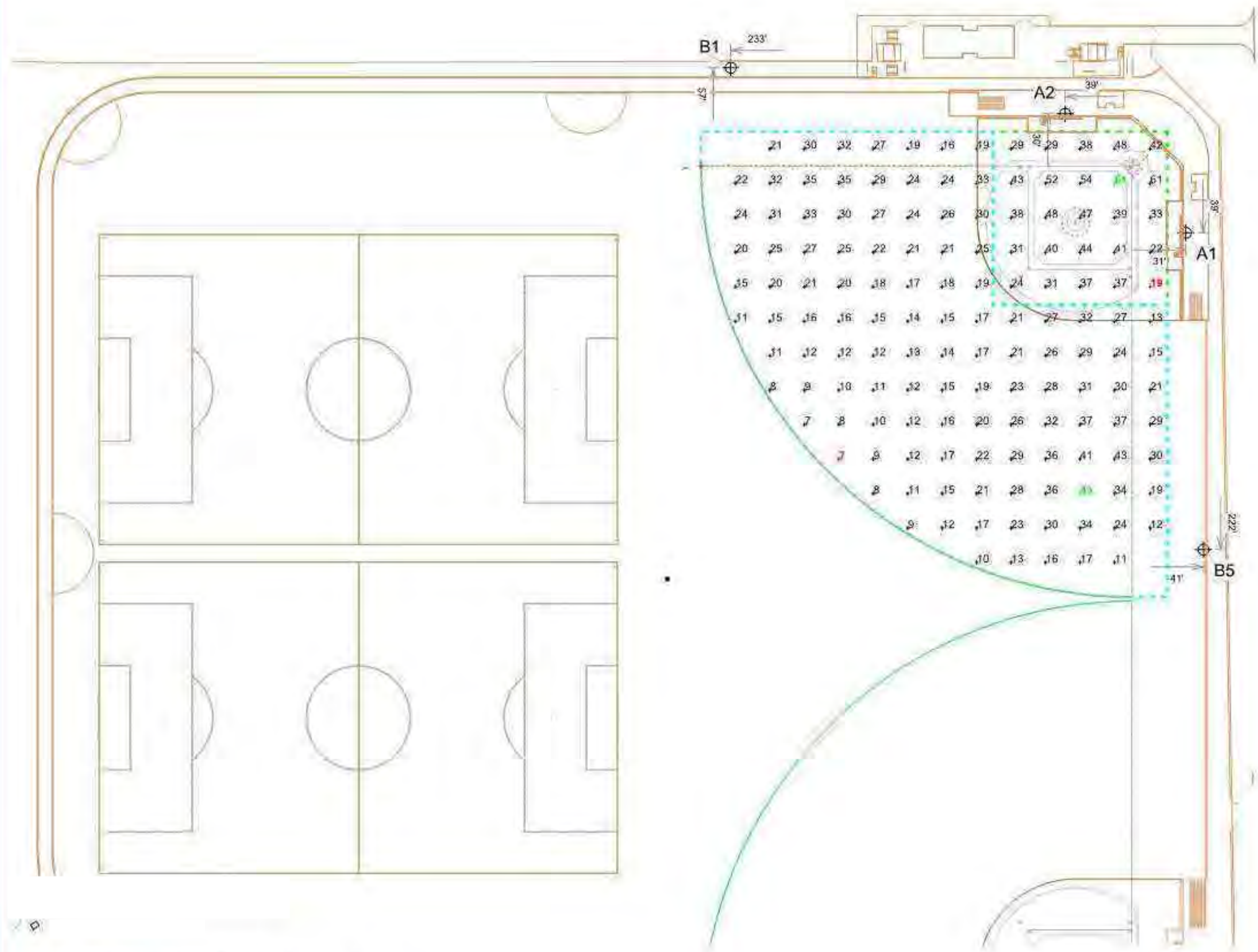

Pole location(s) with dimensions are relative to 0,0 reference point(s)

Light levels reflect poles A1-A2, B1-B2 only.
 ENGINEERED DESIGN By: Daniel Lohman • File #186710J • 31-May-19

ILLUMINATION SUMMARY

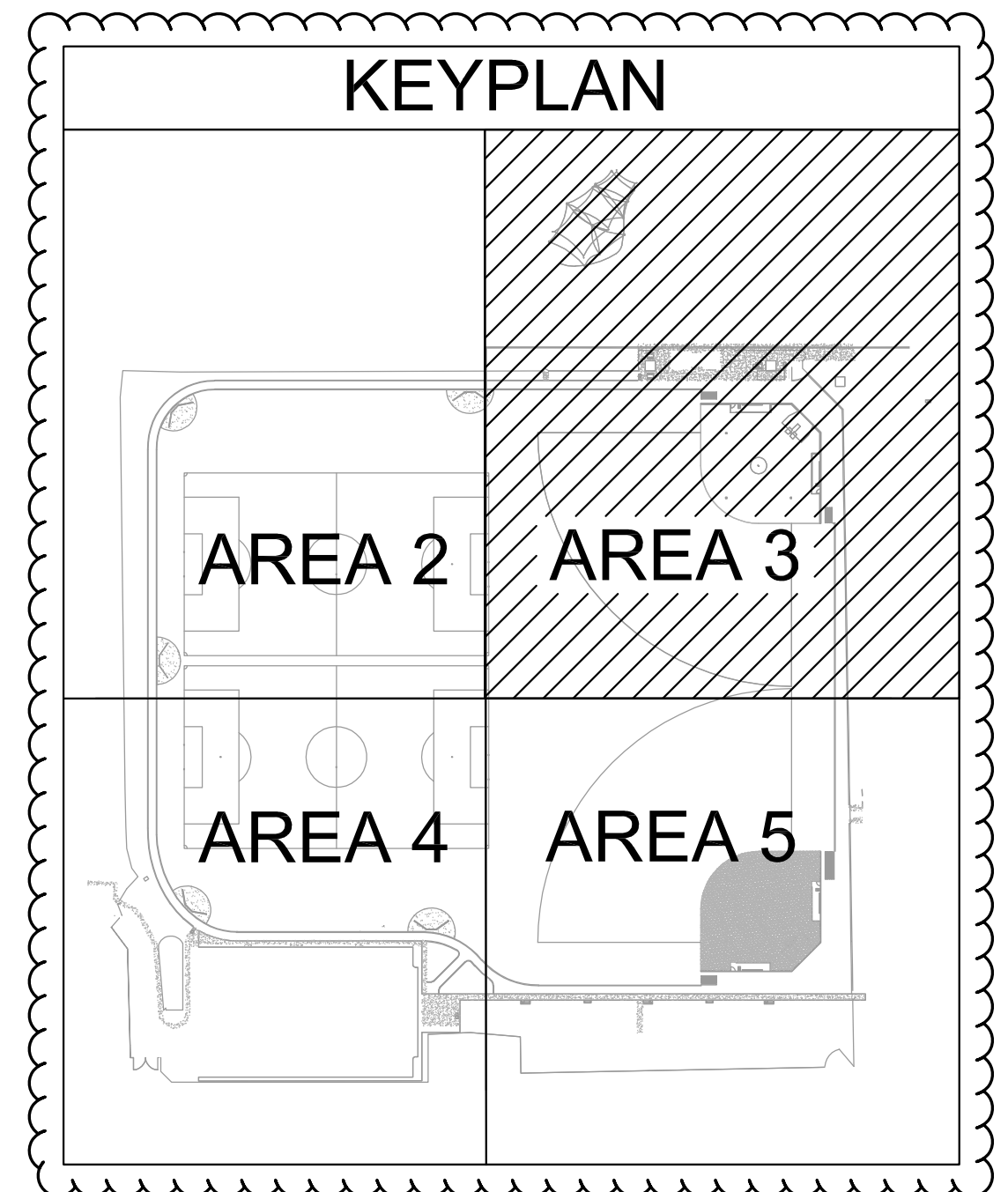

E-17B

WANGENHEIM NEIGHBORHOOD JOINT USE FACILITY ELECTRICAL SPORT LIGHTING DETAILS

SPEC. NO.	CITY OF SAN DIEGO, CALIFORNIA PUBLIC WORKS DEPARTMENT SHEET 130 OF 142 SHEETS	WBS S-15007
APPROVED: FOR CITY ENGINEER JASON GRANI PRINT NAME	DATE 10/13/2020 77208 RCE#	SUBMITTED BY: YOVANNA LEWIS PROJECT MANAGER CHECKED BY: MEHDI RASHIDPOUR-HARISI PROJECT ENGINEER
DESCRIPTION	BY	APPROVED
ORIGINAL REC		
ADDENDUM B REC		1/11/2021
DATE STARTED	DATE COMPLETED	40846-130-D



RICK ENGINEERING COMPANY
 5620 FRIARS ROAD
 SAN DIEGO, CA 92110
 619-291-0707
 (FAX) 619-291-4165
 San Diego
 J-17721
 rickengineering.com

T-SQUARED
 PROFESSIONAL ENGINEERS, INC.
 1340 SPECIALTY DR.
 SUITE E
 VISTA, CA 92081
 TEL: (760) 560-0100
 FAX: (760) 560-0101
 #17056
 12-09-19
 www.tsqeng.com
 E-Mail admin@tsqeng.com

IDENTIFICATION STAMP
 DIV. OF THE STATE ARCHITECT
 APP. 04-118244 INC.
 REVIEWED FOR
 SS FLS ACS
 DATE: 02.14.2020

EQUIPMENT LIST FOR AREAS SHOWN									
QTY	LOCATION	Pole		Luminaires					
		SIZE	GRADE ELEVATION	MOUNTING HEIGHT	LUMINAIRE TYPE	QTY / POLE	THIS GRID	OTHER GRIDS	
2	A3-A4	60'		15.5'	TLC-BT-575	1	1	0	
				60"	TLC-LED-1200	2	2	0	
1	B2	70'		15.5'	TLC-BT-575	2	2	0	
				70"	TLC-LED-1500	5	5	0	
1	B5	70'		15.5'	TLC-BT-575	4	2	2	
				70"	TLC-LED-1500	9	5	4	
4	TOTALS						26	20	6

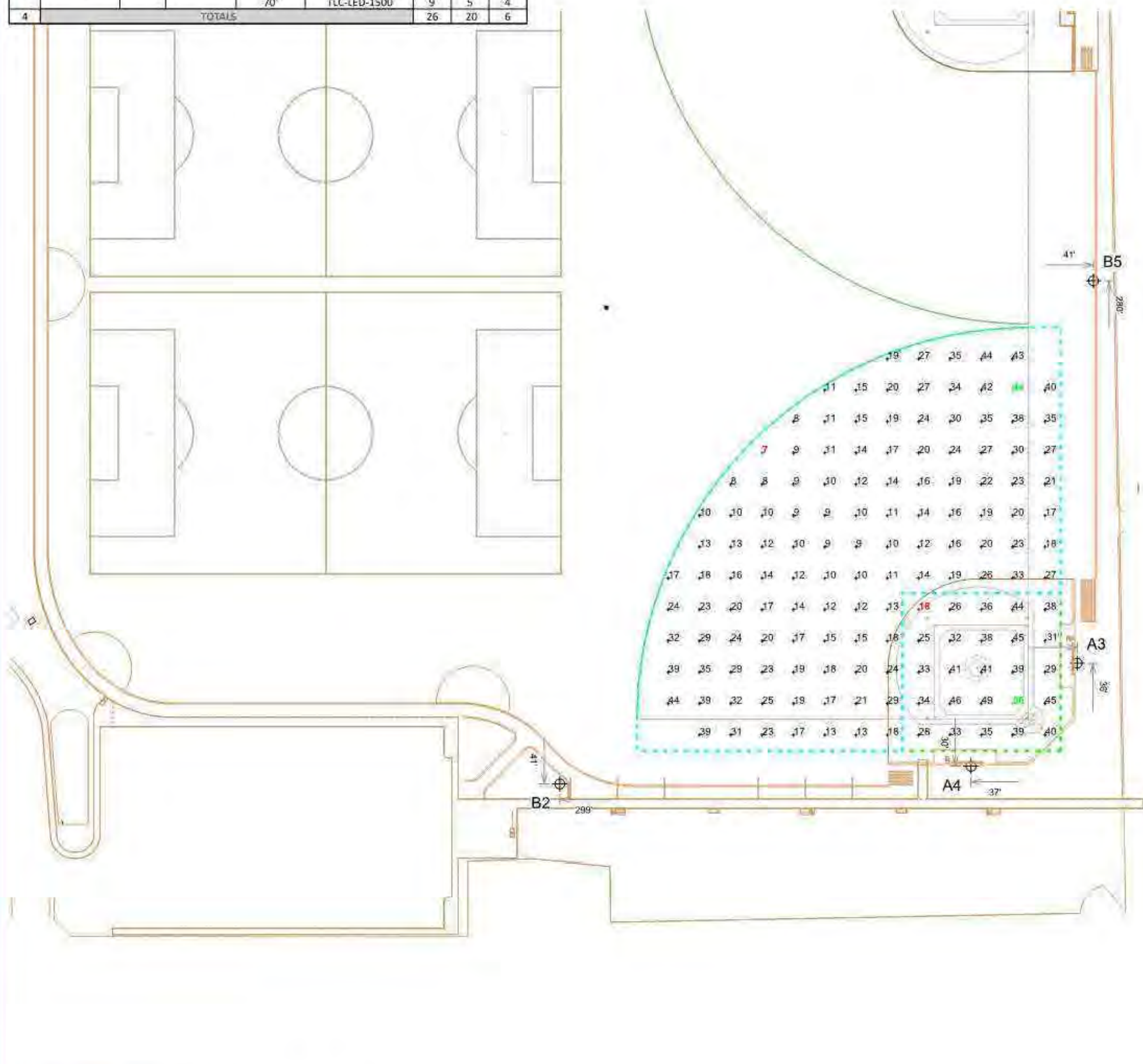

Light levels reflect poles A1-A2, B1, B3 only. 160'

Pole location(s) dimensions are relative to 0,0 reference point(s)

ENGINEERED DESIGN By: Daniel Lohman • File #186710J • 31-May-19

Wangenheim School Park San Diego, CA

GRID SUMMARY	
Name:	Field #2
Size:	250'/250'/250' - basepath 60'
Spacing:	20.0' x 20.0'
Height:	3.0' above grade

ILLUMINATION SUMMARY			
MAINTAINED HORIZONTAL FOOT CANDLES			
	Infield	Outfield	
Scan Average:	36.8	20.2	
Maximum:	55.9	44.1	
Minimum:	18.2	7.1	
Avg / Min:	2.02	2.83	
Max / Min:	3.07	6.18	
UG (adjacent pts):	1.57	1.56	
CU:	0.55		
No. of Points:	25	119	

LUMINAIRE INFORMATION			
Color / CRI:	5700K - 75 CRI		
Luminaire Output:	160,000 / 52,000 / 136,000 lumens		
No. of Luminaires:	20		
Total Load:	22.43 kW		
Lumen Maintenance			
Luminaire Type	L90 hrs	L80 hrs	L70 hrs
TLC-LED-1500	>81,000	>81,000	>81,000
TLC-BT-575	>81,000	>81,000	>81,000
TLC-LED-1200	>81,000	>81,000	>81,000

Reported per TM-21-11. See luminaire datasheet for details.

Guaranteed Performance: The ILLUMINATION described above is guaranteed per your Musco Warranty document and includes a 0.95 dirt depreciation factor.

Field Measurements: Individual field measurements may vary from computer-calculated predictions and should be taken in accordance with IESNA RP-6-15.

Electrical System Requirements: Refer to Amperage Draw Chart and/or the "Musco Control System Summary" for electrical sizing.

Installation Requirements: Results assume ± 3% nominal voltage at line side of the driver and structures located within 3 feet (1m) of design locations.

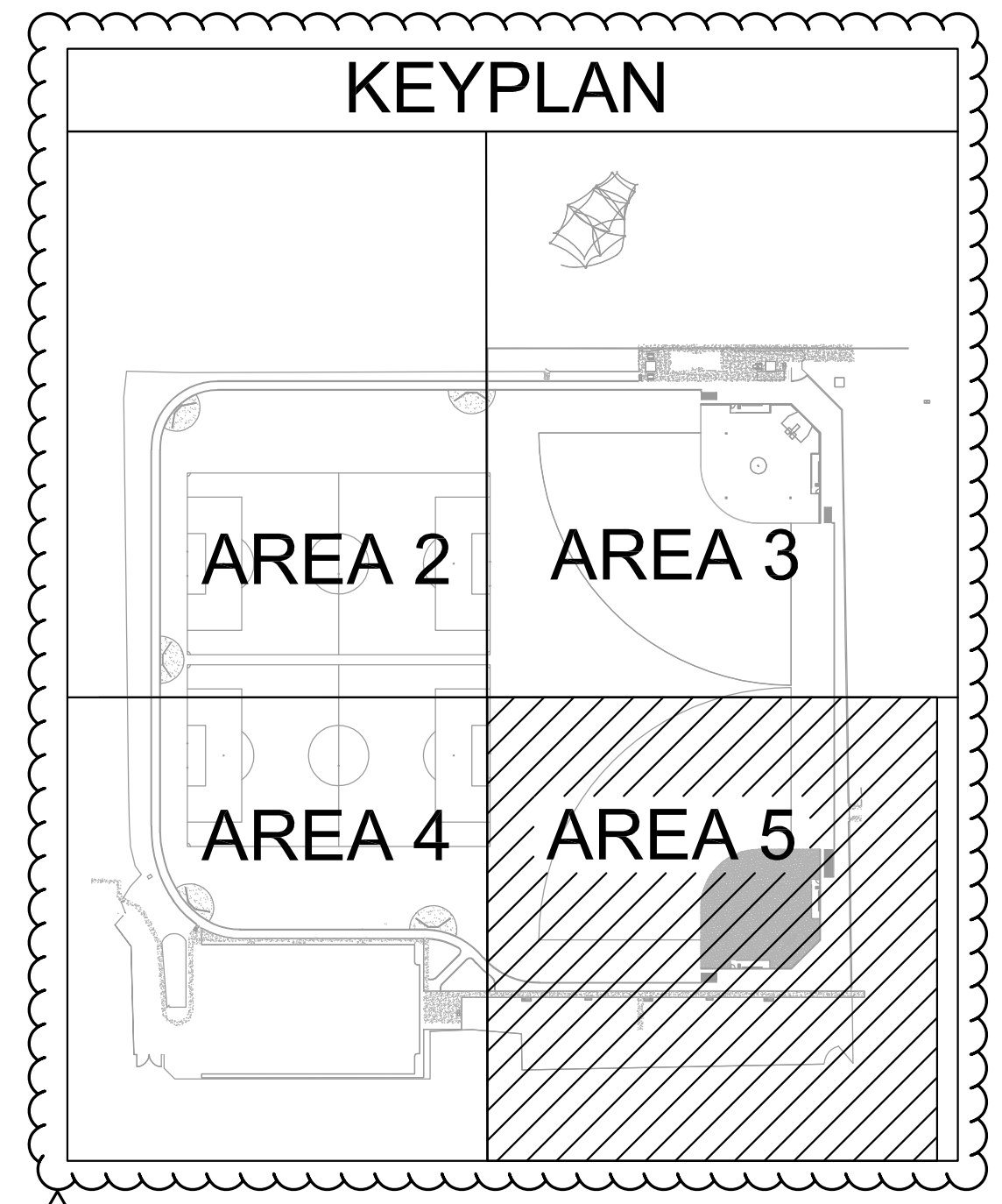

E-17C

WANGENHEIM NEIGHBORHOOD JOINT USE FACILITY

ELECTRICAL SPORT LIGHTING DETAILS

SPEC. NO.	CITY OF SAN DIEGO, CALIFORNIA PUBLIC WORKS DEPARTMENT SHEET 131 OF 142 SHEETS		WBS	S-15007
APPROVED:	FOR CITY ENGINEER JASON GRANI	DATE 10/13/2020 77208	SUBMITTED BY: YOVANNA LEWIS PROJECT MANAGER	
PRINT NAME		RCE#	CHECKED BY: MEHDI RASHIDPOUR-HARISI PROJECT ENGINEER	
DESCRIPTION	BY	APPROVED	DATE	FILMED
ORIGINAL	REC			
ADDENDUM B	REC		1/11/2021	
CONTRACTOR	DATE STARTED		40846-131-D	
INSPECTOR	DATE COMPLETED			



1340 SPECIALTY DR.
SUITE E
VISTA, CA 92081
TEL: (760) 560-0100
FAX: (760) 560-0101

T-SQUARED
PROFESSIONAL ENGINEERS, INC.

#17056

12-09-19
www.tsqeng.com
E-Mail admin@tsqeng.com

GZ MD JC GZ

RICK ENGINEERING COMPANY
5620 FRIARS ROAD
SAN DIEGO, CA 92110
619-291-0707
(FAX) 619-291-4165

J-17721

rickengineering.com

Riverside - Orange - Sacramento - San Luis Obispo - Phoenix - Tucson - Denver

IDENTIFICATION STAMP
 DIV. OF THE STATE ARCHITECT
 APP. 04-118244 INC.
 REVIEWED FOR
 SS FLS ACS
 DATE: 02.14.2020

EQUIPMENT LIST FOR AREAS SHOWN									
QTY	LOCATION	Pole			Luminaires			THIS GRID	OTHER GRIDS
		SIZE	GRADE ELEVATION	MOUNTING HEIGHT	LUMINAIRE TYPE	QTY / POLE			
4	B3-B4, S1, S3	70'	.1'	70.1'	TLC-LED-1500	4	4	0	
1	B6	70'	.1'	70.1'	TLC-LED-1500	4	4	0	
1	S2	70'	.1'	70.1'	TLC-LED-1500	4	4	0	
1	S4	70'	.1'	70.1'	TLC-LED-1500	5	5	0	
7	TOTALS					29	29	0	

Wangenheim School Park San Diego, CA

GRID SUMMARY	
Name:	Soccer #1
Size:	300' x 180'
Spacing:	30.0' x 30.0'
Height:	3.0' above grade

ILLUMINATION SUMMARY			
MAINTAINED HORIZONTAL FOOT CANDLES			
Entire Grid			
Scan Average:	24.3		
Maximum:	47.1		
Minimum:	3.7		
Avg / Min:	6.53		
Max / Min:	12.68		
UG (adjacent pts):	1.60		
CU:	0.29		
No. of Points:	60		
LUMINAIRE INFORMATION			
Color / CRI:	5700K - 75 CRI		
Luminaire Output:	160,000 lumens		
No. of Luminaires:	29		
Total Load:	41.47 kW		
Lumen Maintenance			
Luminaire Type	L90 hrs	L80 hrs	L70 hrs
TLC-LED-1500	>81,000	>81,000	>81,000

Reported per TM-21-11. See luminaire datasheet for details.

Guaranteed Performance: The ILLUMINATION described above is guaranteed per your Musco Warranty document and includes a 0.95 dirt depreciation factor.

Field Measurements: Individual field measurements may vary from computer-calculated predictions and should be taken in accordance with IESNA RP-6-15.

Electrical System Requirements: Refer to Amperage Draw Chart and/or the "Musco Control System Summary" for electrical sizing.

Installation Requirements: Results assume ± 3% nominal voltage at line side of the driver and structures located within 3 feet (1m) of design locations.

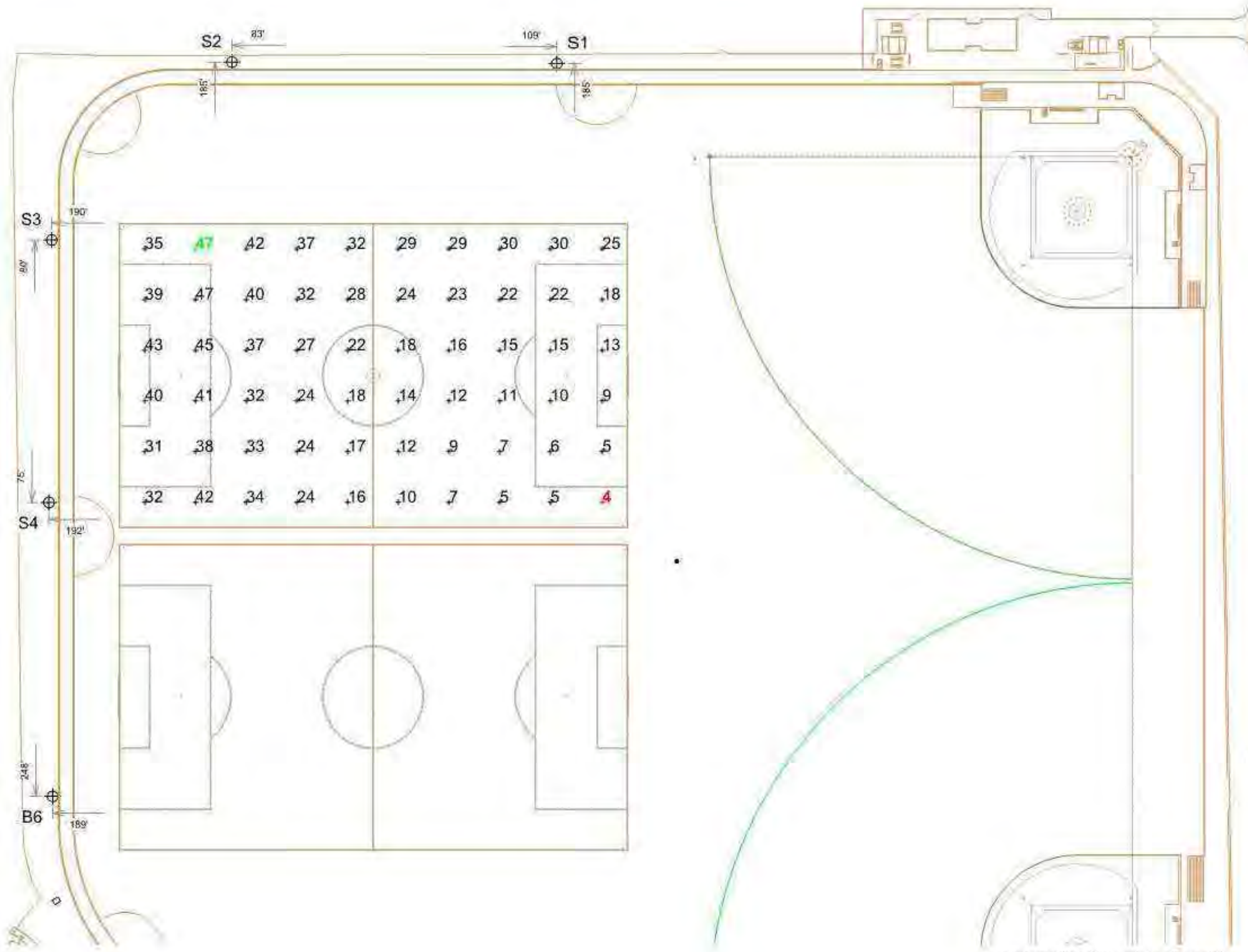

Poles S3, S4, and S5 are in glare zones for one or both soccer fields. Light levels reflect poles S1-S4 only.

ENGINEERED DESIGN BY: DANIEL LONMAN • File #186710J • 31-May-19

ILLUMINATION SUMMARY

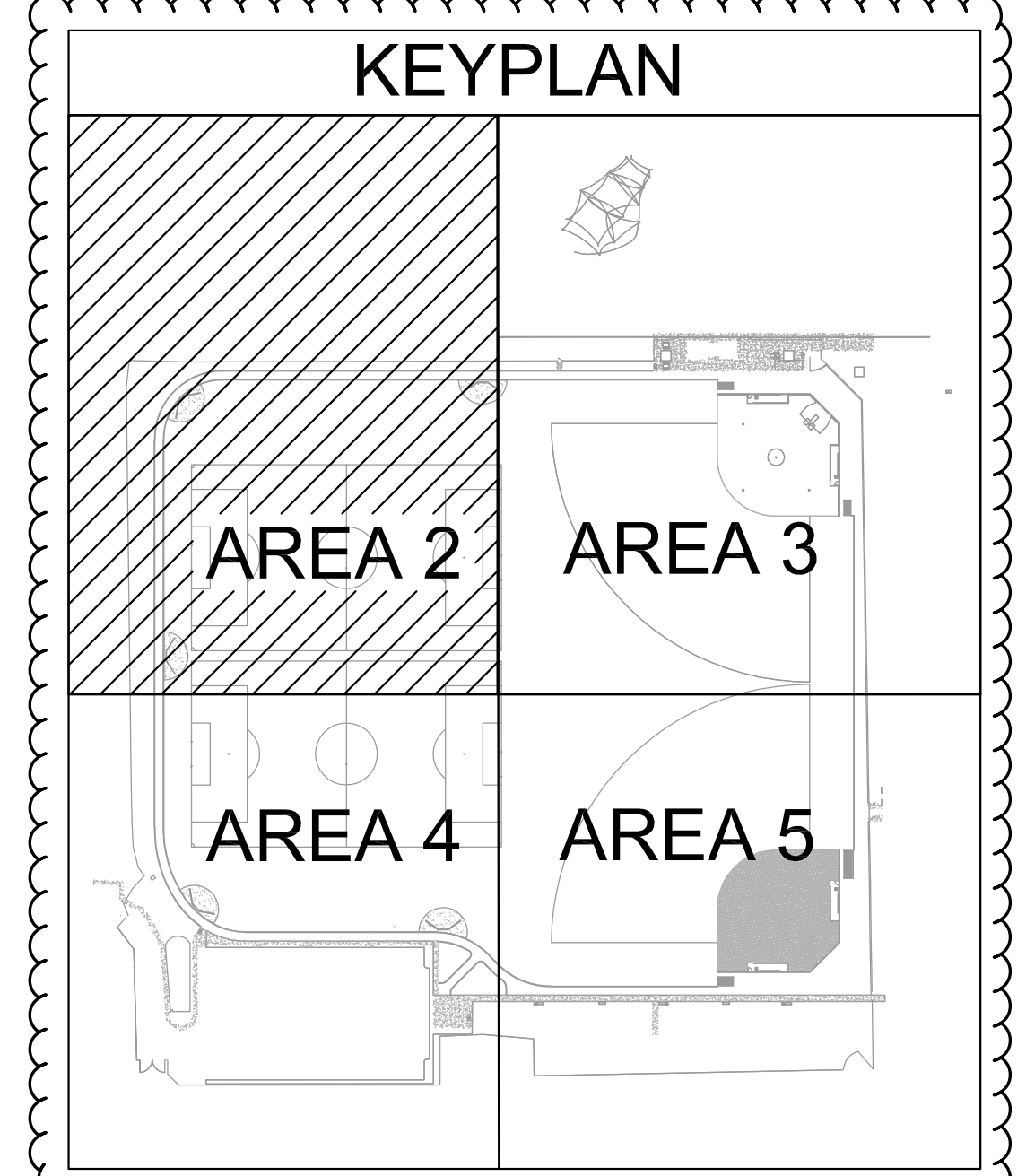

E-17D

WANGENHEIM NEIGHBORHOOD JOINT USE FACILITY ELECTRICAL SPORT LIGHTING DETAILS

SPEC. NO.	CITY OF SAN DIEGO, CALIFORNIA PUBLIC WORKS DEPARTMENT SHEET 132 OF 142 SHEETS	WBS	S-15007
APPROVED:	FOR CITY ENGINEER JASON GRANI PRINT NAME	DATE	10/13/2020 77208
FOR CITY ENGINEER	JASON GRANI	DATE	10/13/2020
PRINT NAME	JASON GRANI	RCE#	77208
DESCRIPTION	BY	APPROVED	DATE
ORIGINAL	REC		
ADDENDUM B	REC		1/11/2021
DESCRIPTION	BY	APPROVED	DATE
ORIGINAL	REC		
ADDENDUM B	REC		1/11/2021
DESCRIPTION	BY	APPROVED	DATE
ORIGINAL	REC		
ADDENDUM B	REC		1/11/2021
CONTRACTOR	INSPECTOR	DATE STARTED	DATE COMPLETED

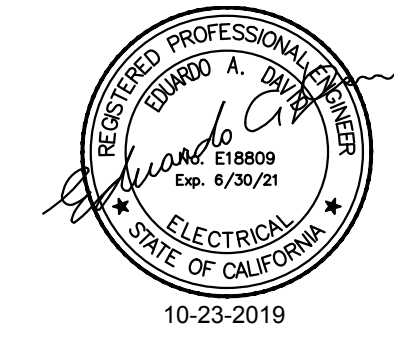

RICK ENGINEERING COMPANY
 5620 FRIARS ROAD
 SAN DIEGO, CA 92110
 619-291-0707
 (FAX) 619-291-4165
 rickengineering.com
 San Diego

T-SQUARED
 PROFESSIONAL ENGINEERS, INC.
 1340 SPECIALTY DR.
 SUITE E
 VISTA, CA 92081
 TEL: (760) 560-0100
 FAX: (760) 560-0101
 #17056
 12-09-19
 www.tsqeng.com
 E-Mail admin@tsqeng.com

IDENTIFICATION STAMP
 DIV. OF THE STATE ARCHITECT
 APP. 04-118244 INC.
 REVIEWED FOR
 SS FLS ACS
 DATE: 02.14.2020

EQUIPMENT LIST FOR AREAS SHOWN							
QTY	Pole			Luminaires			OTHER GRIDS
	LOCATION	SIZE	GRADE ELEVATION	MOUNTING HEIGHT	LUMINAIRE TYPE	QTY / POLE	
4	B3-B4, S1	70"	.1'	70.1'	TLC-LED-1500	4	4
1	B6	70"	.1'	70.1'	TLC-LED-1500	4	4
1	S2	70"	.1'	70.1'	TLC-LED-1500	4	4
1	S4	70"	.1'	70.1'	TLC-LED-1500	5	5
7	TOTALS					29	29

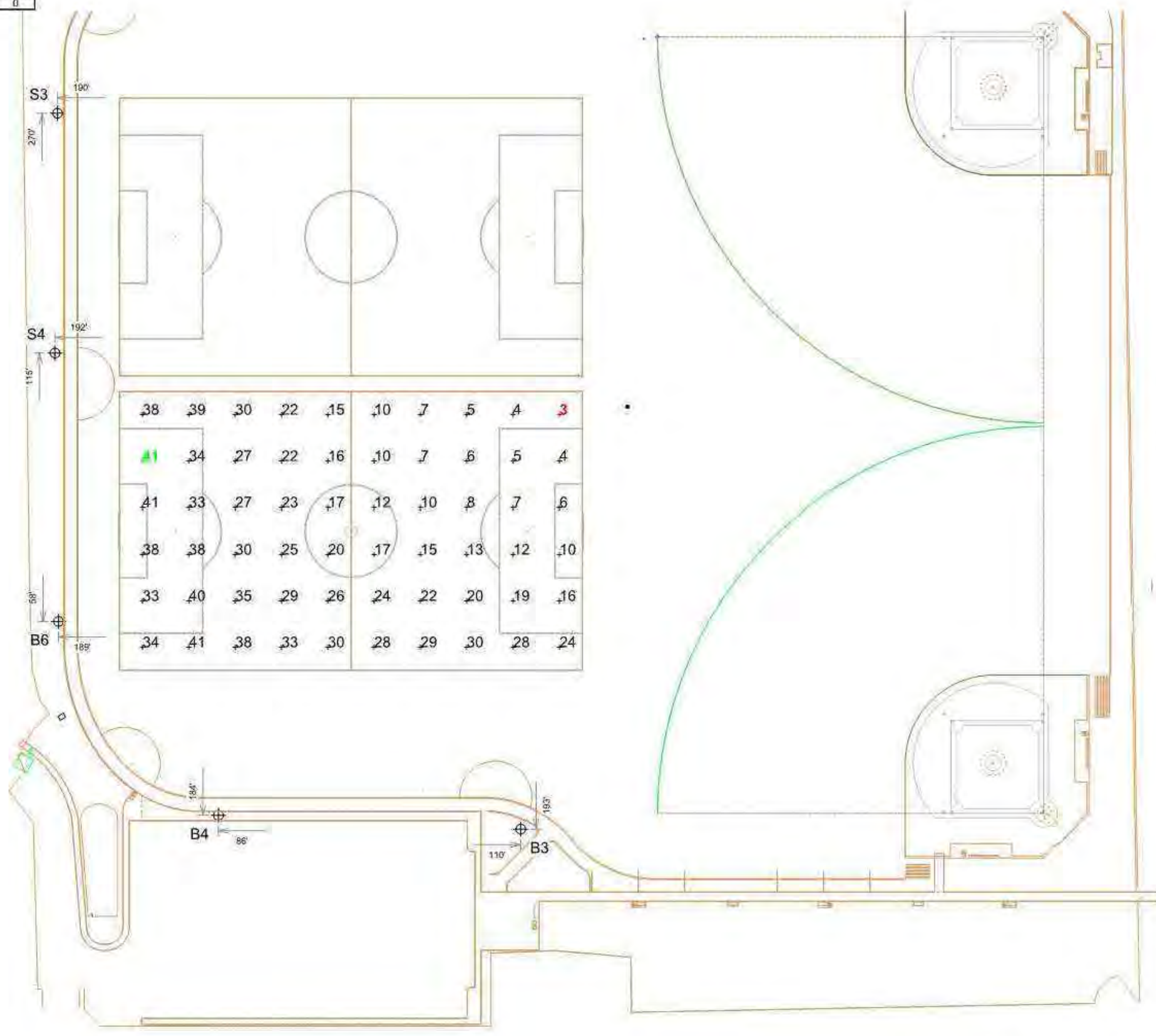

.38	.39	.30	.22	.15	.10	.7	.5	.4	.3
.41	.34	.27	.22	.16	.10	.7	.6	.5	.4
.38	.38	.30	.25	.20	.17	.15	.13	.12	.10
.33	.40	.35	.29	.26	.24	.22	.20	.19	.16
.34	.41	.38	.33	.30	.28	.29	.30	.28	.24

Wangenheim School Park San Diego, CA

GRID SUMMARY	
Name:	Soccer #2
Size:	300' x 180'
Spacing:	30.0' x 30.0'
Height:	3.0' above grade

ILLUMINATION SUMMARY			
MAINTAINED HORIZONTAL FOOT CANDLES			
Entire Grid			
Scan Average:	22.1		
Maximum:	41.4		
Minimum:	3.1		
Avg / Min:	7.13		
Max / Min:	13.33		
UG (adjacent pts):	1.77		
CU:	0.26		
No. of Points:	60		
LUMINAIRE INFORMATION			
Color / CRI:	5700K - 75 CRI		
Luminaire Output:	160,000 lumens		
No. of Luminaires:	29		
Total Load:	41.47 kW		
Luminaire Maintenance			
Luminaire Type	L90 hrs	L80 hrs	L70 hrs
TLC-LED-1500	>81,000	>81,000	>81,000

Reported per TM-21-11. See luminaire datasheet for details.

Guaranteed Performance: The ILLUMINATION described above is guaranteed per your Musco Warranty document and includes a 0.95 dirt depreciation factor.

Field Measurements: Individual field measurements may vary from computer-calculated predictions and should be taken in accordance with IESNA RP-6-15.

Electrical System Requirements: Refer to Amperage Draw Chart and/or the "Musco Control System Summary" for electrical sizing.

Installation Requirements: Results assume ± 3% nominal voltage at line side of the driver and structures located within 3 feet (1m) of design locations.

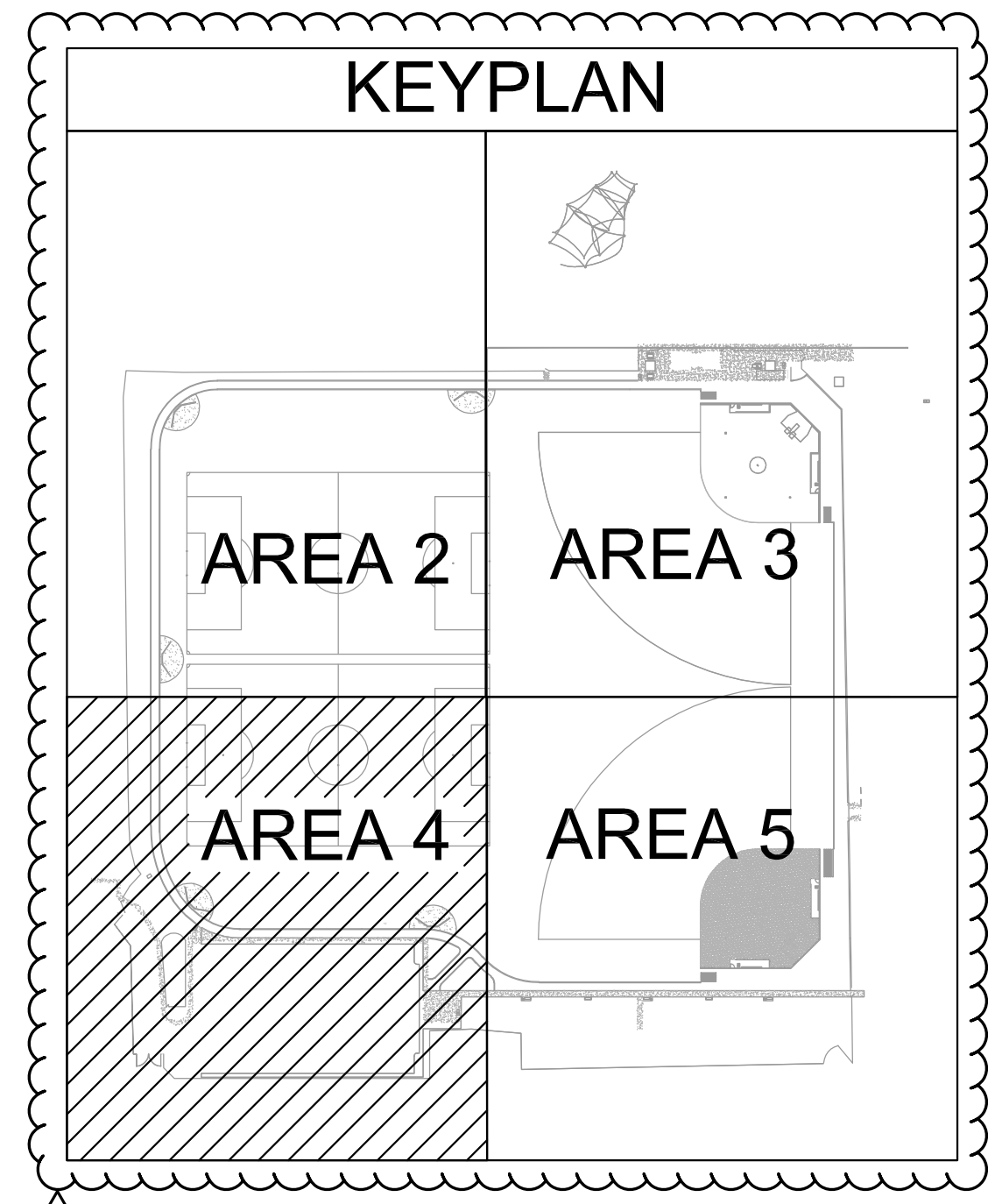

E-17E

WANGENHEIM NEIGHBORHOOD JOINT USE FACILITY

ELECTRICAL SPORT LIGHTING DETAILS

SPEC. NO.	CITY OF SAN DIEGO, CALIFORNIA PUBLIC WORKS DEPARTMENT SHEET 133 OF 142 SHEETS	WBS	S-15007		
APPROVED:	FOR CITY ENGINEER JASON GRANI	DATE	10/13/2020 77208		
PRINT NAME	RCE#	CHECKED BY	YOVANNA LEWIS PROJECT MANAGER		
DESCRIPTION	BY	APPROVED	DATE	FILMED	MEHDI RASHIDPOUR-HARISI PROJECT ENGINEER
ORIGINAL	REC				270-1731 (NAD27)
ADDENDUM B	REC		1/11/2021		CCS27 COORDINATE
					1910-6291 (NAD83)
					CCS83 COORDINATE
CONTRACTOR	INSPECTOR	DATE STARTED	DATE COMPLETED	40846-133-D	

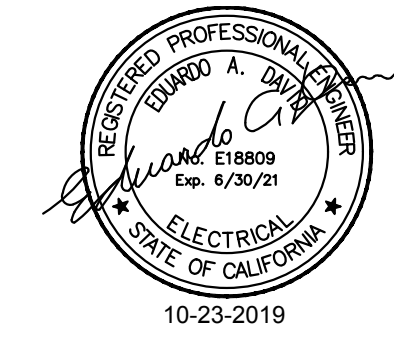

RICK ENGINEERING COMPANY
 5620 FRIARS ROAD
 SAN DIEGO, CA 92110
 619-291-0707
 (FAX) 619-291-4165
 rickengineering.com
 San Diego

T-SQUARED
 PROFESSIONAL ENGINEERS, INC.
 1340 SPECIALTY DR.
 SUITE E
 VISTA, CA 92081
 TEL: (760) 560-0100
 FAX: (760) 560-0101
 #17056
 12-09-19
 www.tsqeng.com
 E-Mail admin@tsqeng.com

GENERAL NOTES

DESIGN LOADS

BUILDING CODE CBC 2016 (BASED ON IBC 2015)
 LIVE LOADS 5 PSF
 SNOW LOAD 5 PSF
 WIND LOADS 115 MPH (3-Sec. Gust); RISK CATEGORY II; EXPOSURE C;
 TOPOGRAPHIC FACTOR $K_{zt} = 1.00$
 VELOCITY PRESSURE $q_z = 25.32$ PSF
 COMPONENT AND CLADDING q_z
 (CABLE AND CABLE HARDWARE ONLY) = 25.32 PSF

DEAD LOAD
 SUPERIMPOSED LOADS N/A

SEISMIC DESIGN:
 SEISMIC IMPORTANCE FACTOR $I_E = 1.00$
 RISK CATEGORY II
 SITE CLASS D
 SITE COEFFICIENT CATEGORY $F_a = 1.132$ $F_v = 1.658$
 MAPPED SPECTRAL RESPONSE COEFF $S_s = 0.921$ $S_1 = 0.358$
 SPECTRAL RESPONSE COEFFICIENTS $S_{D1} = 0.695$ $S_{D1} = 0.402$
 SEISMIC DESIGN CATEGORY D
 LATERAL FORCE RESISTING SYSTEM G.2 ORDINARY CANTILEVERED COLUMN SYSTEM.
 TOTAL WEIGHT OF THE BUILDING 11,454 LB
 DESIGN BASE SHEAR $V = 6,368$ LB
 $C_s = 0.556$
 RESPONSE MODIFICATION FACTOR $R = 1.25$
 SYSTEM OVER-STRENGTH FACTOR $\Omega = 1.25$
 DEFLECTION AMPLIFICATION FACTOR $C_d = 1.25$
 REDUNDANCY FACTOR 1.3
 ANALYSIS PROCEDURE EQUIVALENT LATERAL FORCE

SOIL PARAMETERS FOR FOOTING ANALYSIS:
 FOUNDATION DESIGN BASED ON CBC 2016, TABLE 1806.2, SOIL CLASS TYPE 4
 ALLOWABLE SOIL PRESSURE:
 DL + LL 2000 PSF
 DL + LL + SEISMIC 2000 PSF
 LATERAL BEARING DESIGN VALUE 150 PSF/F BELOW NATURAL GRADE, PER TABLE 1806A.2

GEOTECHNICAL REPORT BY: ALLIED GEOTECHNICAL ENGINEERS, INC.
 AGE PROJECT NO. 177 GS-15-A, DATED ON FEBRUARY 7, 2017, AND FOUNDATION REVIEW LETTER DATED ON OCTOBER 14, 2019.

DESIGN PER FOLLOWING CODES:
 CBC 2016, ASCE 7-10, AISC 360-10 (ASD 14TH EDITION), ACI 318-14, ASCE 55-10, ASCE 19-10

REINFORCED CONCRETE NOTES

- CONCRETE WORK SHALL BE EXECUTED IN ACCORDANCE WITH THE LATEST ADOPTED EDITION OF THE AMERICAN CONCRETE INSTITUTE SPECIFICATION FOR STRUCTURAL CONCRETE ACI 301 AND BUILDING CODE ACI 318. CONCRETE SPECIFICATIONS, SHALL BE AS FOLLOWS:
 -28 DAY STRENGTH: 4500 PSI
 -SLUMP: 3-5
 -PORTLAND CEMENT SHALL CONFORM TO C-150
 -AGGREGATE SHALL CONFORM TO ASTM C-33
 -CONCRETE SHALL CONFORM TO ACI-318-14, TABLE 19.3.2.1 REQUIREMENTS
 -CEMENT TYPE: V
 -MAXIMUM WATER-CEMENTITIOUS MATERIAL RATIO: 0.45
- CONCRETE SHALL BE TESTED PER CBC 2016, SECTION 1903A & SHALL BE INSPECTED PER SECTION 1903A, CHAPTER 17A, 1705A.3, TABLE 1705A.3.
- ALL REINFORCEMENT STEEL SHALL CONFORM TO ASTM A-615 GRADE 60; AND SHALL BE DETAILED, FABRICATED AND PLACED IN ACCORDANCE WITH THE LATEST SPECIFICATION FOR STRUCTURAL CONCRETE ACI 301, ACI DETAILING MANUAL AND CRSI MANUAL OF STANDARD PRACTICE.
- ALL ANCHOR BOLTS SET IN NEW CONCRETE (WHEN APPLICABLE) SHALL COMPLY WITH ASTM F-1554 GRADE 55 (GALVANIZED). ANCHOR BOLT'S EMBEDMENT NEEDS TO BE AS FOLLOWS:
 A) ANCHOR BOLT $\varnothing 1-1/4"$ 30 IN (MINIMUM EMBEDMENT),
- CERTIFIED MILL TEST REPORTS ARE TO BE PROVIDED FOR EACH SHIPMENT OF REINFORCEMENT.
- ALL NON-SHRINK GROUT SHALL HAVE A MINIMUM 28 DAYS COMPRESSIVE STRENGTH OF 5000 PSI, AND SHALL COMPLY THE REQUIREMENTS OF ASTM C109, ASTM C939, ASTM C1090, ASTM C1107, WHEN APPLICABLE.

STRUCTURAL STEEL

- FABRICATION OF THE STEEL STRUCTURES SHALL BE PERFORMED BY USA SHADE OR AN AUTHORIZED LICENSEE. MATERIAL TESTING (OR MILL CERTIFICATES) AND INSPECTION OF WELDING SHALL BE CONDUCTED PER CBC 2016 SECTIONS 1704A, 1705A, 1705A.2, AND TABLE 1705A.2.1.
- ONLY CALIFORNIA LICENSED CONTRACTORS AUTHORIZED BY USA SHADE SHALL INSTALL THE SHADE STRUCTURES.
- ALL WORK SHALL CONFORM TO CBC 2016 EDITION, TITLE 24, CALIFORNIA CODE OF REGULATIONS (CCR).
- ALL STRUCTURAL SHAPES SHALL BE COLD FORMED HSS ASTM A500 GRADE B, UNLESS OTHERWISE NOTED. TYPICAL MECHANICAL PROPERTIES ACHIEVED FOR HSS PRODUCTS:
 HSS 14 x 0.375 42,000 PSI YIELD STRESS / 58,000 PSI TENSILE STRESS
 HSS 16 x 0.500 42,000 PSI YIELD STRESS / 58,000 PSI TENSILE STRESS
- ALL PLATES PRODUCTS SHALL COMPLY WITH ASTM A572 GRADE 50.
- STRUCTURAL STEEL SHALL BE DETAILED, FABRICATED AND ERECTED IN ACCORDANCE WITH A.I.S.C. SPECIFICATIONS.
- ALL WELDING TO CONFORM WITH AMERICAN WELDING SOCIETY STANDARDS AND SHALL BE INSPECTED BY AN AWS/CWI INSPECTOR. AWS D1.1 FOR HOT ROLLED. AWS D1.3 FOR SHEET/COLD FORMED. AWS D1.8 SEISMIC SUPPLEMENT FOR COLUMN WELDS.
- SHOP CONNECTIONS SHALL BE WELDED UNLESS NOTED OTHERWISE. FIELD CONNECTIONS SHALL BE AS INDICATED ON THE DRAWINGS (IF REQUIRED). ALL FILLET WELDS SHALL BE A MINIMUM OF 3/16" ER70SX ELECTRODES UNLESS OTHERWISE NOTED. EITHER SMAW OR GMAW IS ACCEPTABLE.
- ALL FULL PENETRATION WELD SHALL BE CONTINUOUSLY INSPECTED PER AWS D1.1 & D1.8.
- ALL STRUCTURAL STEEL SHALL BE PAINTED WITH ONE SHOP COAT (2.5 TO 3.5 MILS THICK MIN). THIS COAT IS A WEATHER RESISTANT POWDER COATING BASED ON POLYESTER TGIC (MANUFACTURED BY SHERWIN WILLIAMS OR TIGER DRYLAC). TO ACHIEVE OPTIMUM ADHESION, IT IS RECOMMENDED THAT THE PROPER TREATMENT AND DRYING TAKE PLACE BEFORE COATING. POLYESTER POWDER (TGIC) SPECIFICATIONS SHALL BE AS FOLLOWS:
 -PENCIL HARDNESS (ASTM D-3363).
 -HUMIDITY (ASTM D-2247).
 -SOLVENT RESISTANCE (PCI METHOD) - 50 DBL RUBS SL. SOFTNESS.

AIRCRAFT CABLE

- FOR FABRIC ATTACHMENT USE 1/2" 6x19 GALV. CABLE PER ASTM A1023A, ASTM 1023M-02, WITH A BREAKING STRENGTH VALUE OF 20,700 LBS. WIRE ROPE SHALL COMPLY WITH ASCE 19-10. CABLE SHALL BE TENSIONED TO 250 LBS MINIMUM. THE MAXIMUM CALCULATED CABLE TENSION IS 5234 LB.
- CABLES SHALL BE FED THROUGH THE FABRIC SLEEVES AROUND THE PERIMETER OF THE CANOPY AND TENSIONED UNTIL THE FABRIC PANELS (DESIGNED PURPOSELY UNDERSIZED) REACH A TAUT APPEARANCE. ANY LONG TERM CABLE SAG SHALL BE MINIMIZED DURING THE MAINTENANCE RE-TIGHTENING VISITS AS REQUIRED.
- THE CABLE CLAMPS SHALL COMPLY WITH SPECIFICATION FF-C-450 TYPE 1 CLASS 1.

FABRIC SPECIFICATION

- FABRIC SHALL BE MANUFACTURED BY GALE PACIFIC OR OTHER COMPANY WHO CAN MANUFACTURE FABRIC, WHICH MEETS THE SPECIFICATIONS LISTED ON PAGE P-6, AND SHALL BE FABRICATED FROM POLYETHYLENE MATERIALS.
- THE FABRIC SHALL RETAIN 80% OF ITS TENSILE AND TEARING STRENGTH AFTER ULTRAVIOLET EXPOSURE PER ASTM G154 USING A 313 NM LIGHT SOURCE FOR 500 HOURS WHILE MOISTENED FOR 1 HOUR EVERY 12 HOURS.
- PROVIDE CERTIFICATION BY MANUFACTURER AND STATE FIRE MARSHAL TO DSA AT SITE SPECIFIC INSTALLATION.
- FABRIC SHALL REQUIRE ANNUAL INSPECTION AND MAINTENANCE BY THE DISTRICT. FABRICS SAMPLES OF THE SAME MATERIAL WHICH ARE MAINTAINED AT THE PROJECTS SITE SHALL BE TESTED TO BE IN COMPLIANCE WITH ASTM D5035 AND D2261. THE ANNUAL TESTING ON THE APPROVED PLANS SHALL BE COMPARED TO THE FABRIC SPECIFICATIONS INDICATED IN NOTE 1 OF "FABRIC SPECIFICATION" ON THE APPROVED PLANS. THE FABRIC SHALL BE REPLACED WHEN THE TEST RESULTS RETURN LESS THAN 50% OF THE ULTIMATE VALUES IN NOTE 1 OF "FABRIC SPECIFICATION".
- FABRIC TOP NEEDS TO BE REMOVED IF LIVE LOAD EXCEEDING 5 PSF ARE ANTICIPATED, FABRIC TOP NEEDS TO BE REMOVED IF WINDS EXCEEDING 115 MPH ARE ANTICIPATED.
- A VISUAL INSPECTION LOOKING FOR TEAR AND ABNORMAL WEAR IN FABRIC MATERIAL AND THREAD IS REQUIRED PRIOR TO RE-INSTALLATION. SHADE STRUCTURE SHALL BE NOTIFIED IF SIGNIFICANT DAMAGE IS PRESENT BEFORE RE-INSTALLATION.

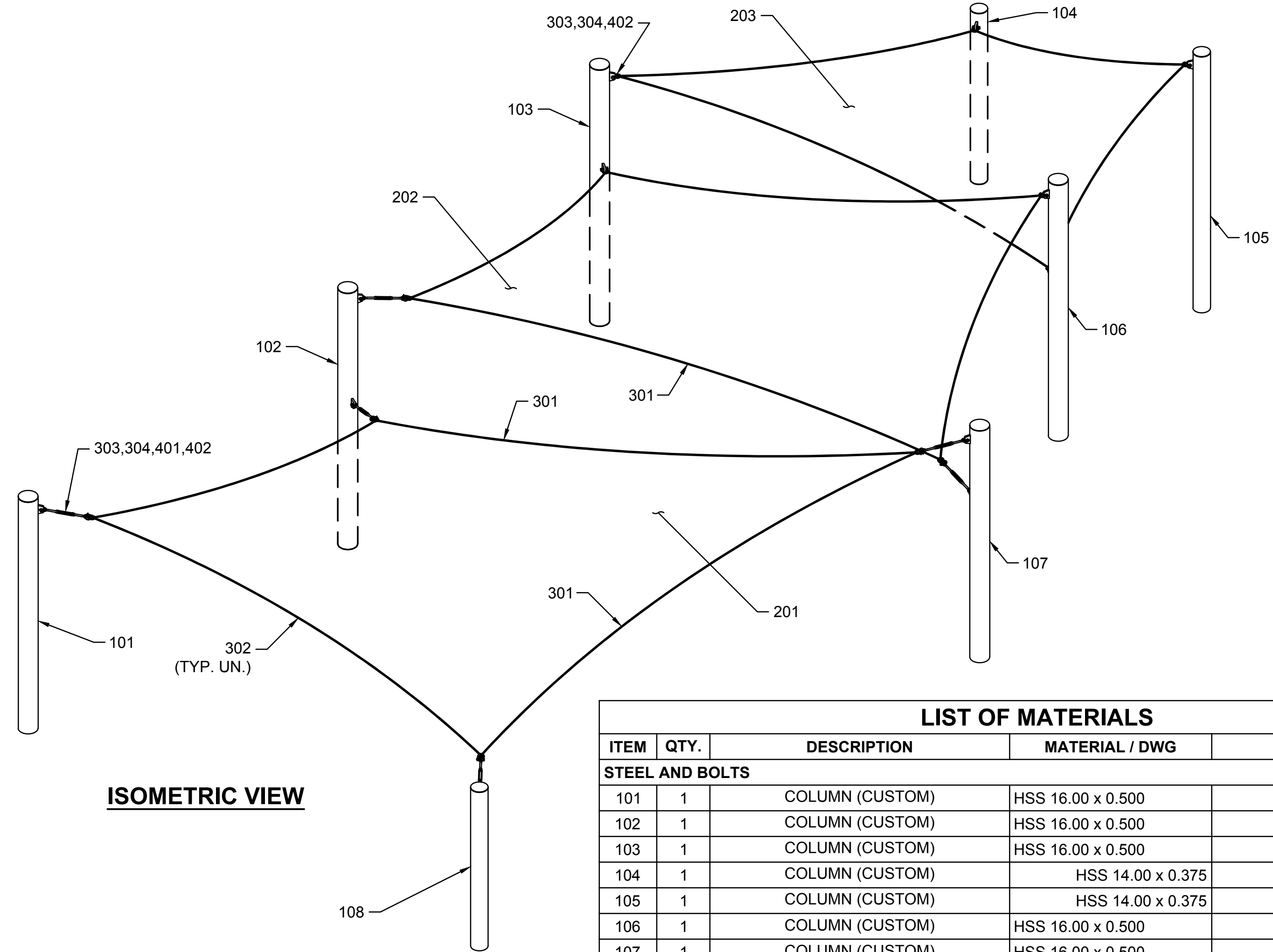

ISOMETRIC VIEW

NOTICE
 FABRIC TOP NEEDS TO BE REMOVED IF SNOW EXCEEDING 5 PSF IS ANTICIPATED
 FABRIC TOP NEEDS TO BE REMOVED IF WINDS EXCEEDING 115 MPH ARE ANTICIPATED, SEE NOTE 1 OF DESIGN LOADS
 INSTALL OVER EXISTING PLAY STRUCTURE (P.I.P)

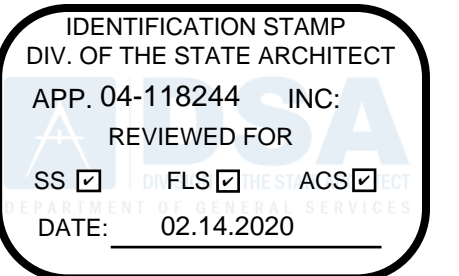

LIST OF MATERIALS				
ITEM	QTY.	DESCRIPTION	MATERIAL / DWG	SMI PART NO.
STEEL AND BOLTS				
101	1	COLUMN (CUSTOM)	HSS 16.00 x 0.500	N/A
102	1	COLUMN (CUSTOM)	HSS 16.00 x 0.500	N/A
103	1	COLUMN (CUSTOM)	HSS 16.00 x 0.500	N/A
104	1	COLUMN (CUSTOM)	HSS 14.00 x 0.375	N/A
105	1	COLUMN (CUSTOM)	HSS 14.00 x 0.375	N/A
106	1	COLUMN (CUSTOM)	HSS 16.00 x 0.500	N/A
107	1	COLUMN (CUSTOM)	HSS 16.00 x 0.500	N/A
108	1	COLUMN (CUSTOM)	HSS 14.00 x 0.375	N/A
11	8	ROD, THREADED 3/4"-10NC x 24"	ASTM A449 GALVANIZED	308237
12	16	$\varnothing 3/4"$ -10NC HEX NUT	ASTM A563 GALVANIZED	307687
13	16	$\varnothing 3/4"$ FLAT WASHER	ASTM F436 GALVANIZED	307624
FABRIC AND HARDWARE				
201	1	FABRIC TOP (CUSTOM)	COMMERCIAL FR 300	AREA: 908 SQF, WEIGHT: 39 LBS
202	1	FABRIC TOP (CUSTOM)	COMMERCIAL FR 300	AREA: 730 SQF, WEIGHT: 31 LBS
203	1	FABRIC TOP (CUSTOM)	COMMERCIAL FR 300	AREA: 445 SQF, WEIGHT: 19 LBS
301	3	55 FT OF 1/2" STEEL CABLE	GALVANIZED CABLE	307605
302	9	45 FT OF 1/2" STEEL CABLE	GALVANIZED CABLE	307605
303	72	$\varnothing 1/2"$ CABLE CLAMP	GALVANIZED	307627
304	24	$\varnothing 5/8"$ THIMBLE	GALVANIZED	309036
401	6	1-1/4" x 12" TURNBUCKLE (JAW-JAW)	GALVANIZED	308954
402	12	1-1/8" ANCHOR SHACKLE	GALVANIZED	308955

CODE ANALYSIS					
BUILDING	OCCUPANCY	CONSTRUCTION TYPE	AREA (SQF)	OCCUPANT LOAD FACTOR	OCCUPANT LOAD
SHADE STRUCTURE	A-3	V-B	3216	15/SQF	215
SIZE: SEE PAGE 2					

PLANS AND DETAILS FOR BID PURPOSES ONLY

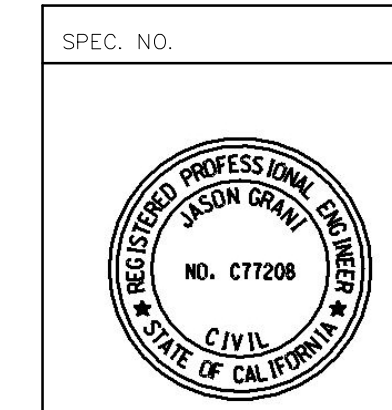
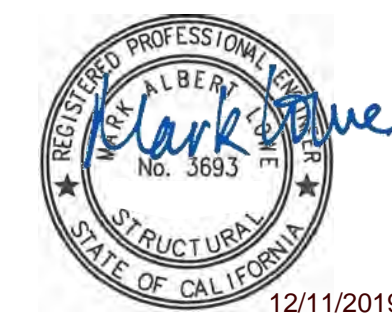

O-1

WANGENHEIM NEIGHBORHOOD JOINT USE FACILITY

SHADE STRUCTURE NOTES / LOM

SPEC. NO. _____

CITY OF SAN DIEGO, CALIFORNIA
 PUBLIC WORKS DEPARTMENT
 SHEET 137 OF 142 SHEETS

WBS S-15007

APPROVED: *[Signature]* 10/13/2020
 FOR CITY ENGINEER JASON GRANI DATE 77208
 PRINT NAME RCE#

SUBMITTED BY: YOVANNA LEWIS PROJECT MANAGER
 CHECKED BY: MEHDI RASHIDPOUR-HARISI PROJECT ENGINEER

DESCRIPTION	BY	APPROVED	DATE	FILMED
ORIGINAL	REC			
ADDENDUM B	REC	<i>[Signature]</i>	1/11/2021	

1910-6291 (NAD83)
 CCS83 COORDINATE

CONTRACTOR _____ DATE STARTED _____
 INSPECTOR _____ DATE COMPLETED _____

40846-137-D

RICK ENGINEERING COMPANY
 5620 FRIARS ROAD
 SAN DIEGO, CA 92110
 619-291-0707
 (FAX) 619-291-4185
 rickengineering.com
 San Diego Riverside - Orange - Sacramento - San Luis Obispo - Phoenix - Tucson - Denver

City of San Diego

CITY CONTACT: Juan E. Espindola, Senior Contract Specialist, Email: JEEspindola@sandiego.gov
Phone No. (619) 533-4491

ADDENDUM C



FOR

WANGENHEIM NEIGHBORHOOD PARK JOINT USE FACILITY

BID NO.:	K-21-1986-DBB-3
SAP NO. (WBS/IO/CC):	S-15007
CLIENT DEPARTMENT:	1714
COUNCIL DISTRICT:	6
PROJECT TYPE:	GB, GF, BS

BID DUE DATE:

**2:00 PM
FEBRUARY 17, 2021**

CITY OF SAN DIEGO'S ELECTRONIC BIDDING SITE, PLANETBIDS

<http://www.sandiego.gov/cip/bidopps/index.shtml>

ENGINEER OF WORK

The Engineering Specifications and Special Provisions contained herein have been prepared by or under the direction of the following Registered Engineer:



1) Registered Engineer

1/20/21

Date

Seal:



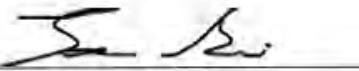

2) For City Engineer

1/28/2021

Date

Seal:



A. CHANGES TO CONTRACT DOCUMENTS

The following changes to the Contract Documents are hereby made effective as though originally issued with the bid package. Bidders are reminded that all previous requirements to this solicitation remain in full force and effect.

THE SUBMITTAL DATE FOR THIS PROJECT HAS BEEN **EXTENDED AS STATED ON THE COVER PAGE.**

B. BIDDER'S QUESTIONS

- Q1. Plan C-7, number 1 call out "Proposed 18" nds square brass grate" does not match Plan C-10 number 1 call out "Proposed 24" nds square brass grate". Are these the proper call outs? Or Are these 18" catch basin as on C-7?
- A1. Please see the revised C-7. Plan C-7 number 1 call out was revised to "Proposed 24" nds square brass grate to match C-10 number 1 call out. These call outs on C-7 propose to install 24" X 24" catch basin.
- Q2. Plan C-10, Does call out 2 proposed 12" cleanout needs to be 12" cleanout on this 8" run?
- A2. This call out should be revised to a number 9 call out, see revised plan of this Addendum.
- Q3. Plan C-10, clarify if legend reference if call out 9 and 1 should be reference call out 3 and 4. Confirm if these are Type I catch basins?
- A3. Plan C-10, these should be revised to a number 3 and 4 call out. Correct, these are proposed to be Type I inlets. See revised plan of this Addendum.
- Q4. What is the size of the Backflow as per drawing C-10 Note: "Exist. 1" Potable water meter to be upsized to 1-1/2" potable water meter for concession stand sourcing". Are we upsizing the backflow as well?
- A4. Existing 1-1/2" backflow device to be PIP, see sheet 59 (L-14).
- Q5. Addendum B RFI response for Q3 points to RFI 3 connection detail. Where can we find that? We cannot locate in Addendum B documents.
- A5. Refer to Connection detail on page 5 of this Addendum.

C. PLANS

1. To Drawing Numbers 40846-1-D, 40846-21-D through 40846-25-D **DELETE** in their entirety and **REPLACE** with pages 6 through 12 of this Addendum.

James Nagelvoort, Director
Engineering & Capital Projects Department

Dated: *January 29, 2021*
San Diego, California

JN/RWB/rd

RFI 3 Connection Detail

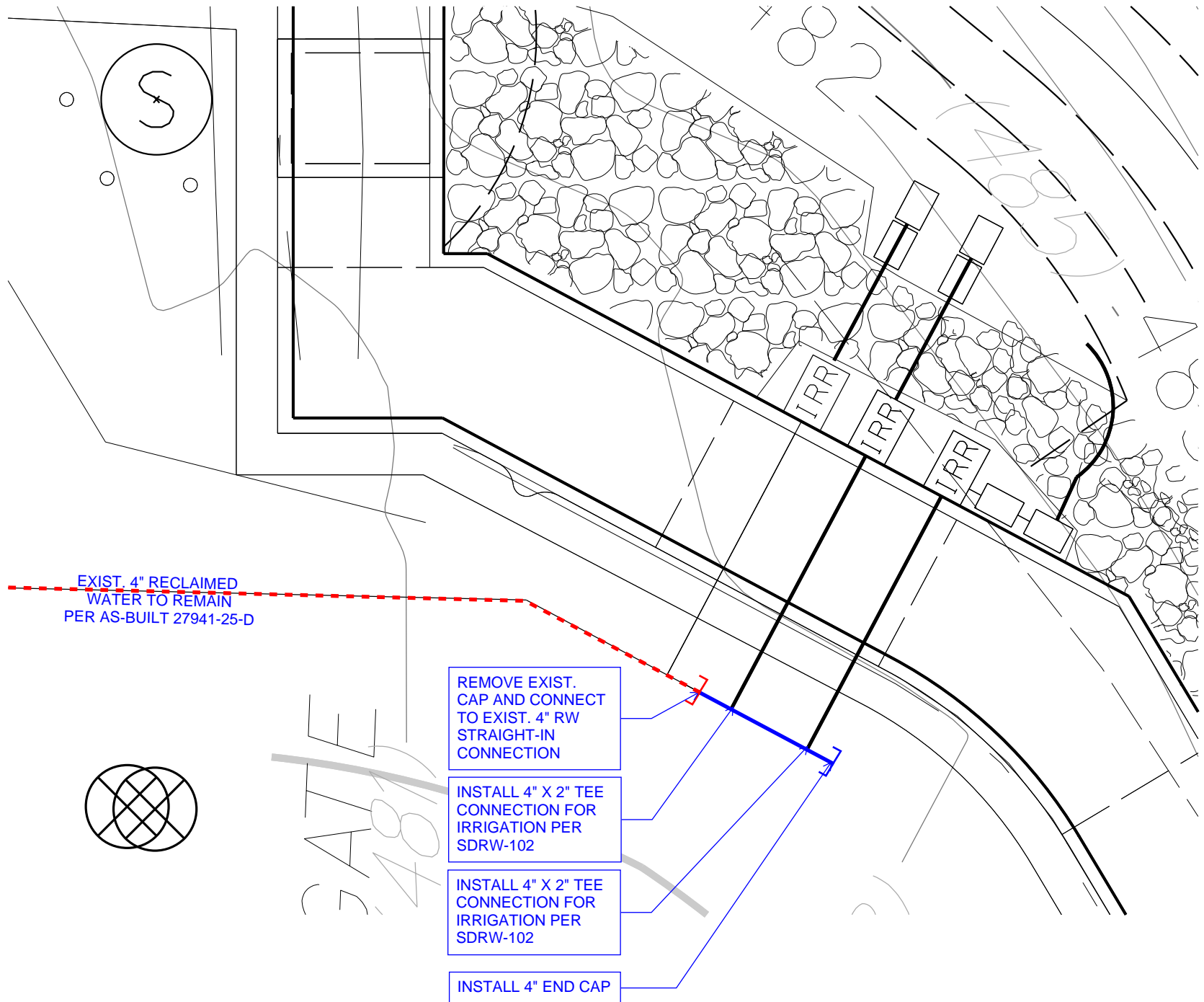

WANGENHEIM NEIGHBORHOOD JOINT USE FACILITY

IDENTIFICATION STAMP
DIV. OF THE STATE ARCHITECT
APP. 04-118244 INC.
REVIEWED FOR
SS FLS ACS
DATE: 02.14.2020

ROOM AREA AND OCCUPANT LOAD SCHEDULE

#	NAME	AREA	OCCUPANCY	OCCUPANT LOAD FACTOR	OCCUPANT LOAD
101	CONCESSION ROOM	173 SF	B	100 GROSS	2
102	STORAGE ROOM	290 SF	B	300 GROSS	1
103	PLUMBING CHASE	83 SF	B	300 GROSS	1
104	ELECTRICAL ROOM	28 SF	B	300 GROSS	1
105	TYPICAL ALL-GENDER RESTROOM	18 SF	B	N/A	N/A
106	ACCESSIBLE ALL-GENDER RESTROOM	40 SF	B	N/A	N/A
107	ACCESSIBLE ALL-GENDER RESTROOM	40 SF	B	N/A	N/A
108	TYPICAL ALL-GENDER RESTROOM	18 SF	B	N/A	N/A
109	AMBULATORY ACCESSIBLE ALL-GENDER RESTROOM	16 SF	B	N/A	N/A
110	ACCESSIBLE ALL-GENDER RESTROOM	40 SF	B	N/A	N/A
111	FAMILY RESTROOM	53 SF	B	N/A	N/A

CODES, STANDARDS AND SPECIFICATIONS

PARTIAL LIST OF APPLICABLE CODES AS OF JANUARY 1, 2017*:

2016 CALIFORNIA ADMINISTRATIVE CODE (CAC), PART 1, TITLE 24 CCR*
2016 CALIFORNIA BUILDING CODE (CBC), PART 2, TITLE 24 CCR
(2015 INTERNATIONAL BUILDING CODE, VOL. 1 & 2, AND 2016 CALIFORNIA AMENDMENTS)
2016 CALIFORNIA ELECTRICAL CODE (CEC), PART 3, TITLE 24 CCR
(2014 NATIONAL ELECTRIC CODE AND 2016 CALIFORNIA AMENDMENTS)
2016 CALIFORNIA MECHANICAL CODE (CMC), PART 4, TITLE 24 CCR
(2015 IAPMO UNIFORM MECHANICAL CODE AND 2016 CALIFORNIA AMENDMENTS)
2016 CALIFORNIA PLUMBING CODE (CPC), PART 5, TITLE 24 CCR
(2015 IAPMO UNIFORM PLUMBING CODE AND 2016 AMENDMENTS)
2016 CALIFORNIA ENERGY CODE, PART 6, TITLE 24 CCR
2016 CALIFORNIA FIRE CODE, PART 9, TITLE 24 CCR
(2015 INTERNATIONAL FIRE CODE AND 2016 CALIFORNIA AMENDMENTS)
2016 EXISTING BUILDING CODE (CEBC), PART 10, TITLE 24 CCR
(2015 INTERNATIONAL EXISTING BUILDING CODE AND 2016 CALIFORNIA AMENDMENTS)
2016 CALIFORNIA GREEN BUILDING STANDARDS CODE (CALGreen), PART 11, TITLE 24 CCR
2016 CALIFORNIA REFERENCED STANDARDS, PART 12, TITLE 24 CCR
AND AMENDMENTS IN SAN DIEGO MUNICIPAL CODE, JULY 2013
TITLE 19 CCR, PUBLIC SAFETY, STATE FIRE MARSHAL REGULATIONS
2013 ASME A17.1 / CSA B44-13 SAFETY CODE FOR ELEVATORS AND ESCALATORS

PARTIAL LIST OF APPLICABLE STANDARDS:

NFPA 13 STANDARD FOR INSTALLATION OF SPRINKLER SYSTEMS (CA AMENDED) 2016 ED.
NFPA 14 STANDARD FOR INSTALLATION OF STANDPIPE AND HOSE SYSTEMS, 2013 ED.
NFPA 17 STANDARD FOR DRY CHEMICAL EXTINGUISHING SYSTEMS, 2013 ED.
NFPA 17A STANDARD FOR WET CHEMICAL EXTINGUISHING SYSTEMS, 2013 ED.
NFPA 20 STANDARD FOR THE INSTALLATION OF STATIONARY PUMPS FOR FIRE PROTECTION, 2016 ED.
NFPA 22 STANDARD FOR WATER TANKS FOR PRIVATE FOR PROTECTION, 2013 ED.
NFPA 24 STANDARD FOR INSTALLATION OF PRIVATE FIRE SERVICE MAINS AND THEIR APPURTENANCES, 2016 ED.
NFPA 72 NATIONAL FIRE ALARM AND SIGNALING CODE (CA. AMENDED) 2016 ED.
(SEE UL STANDARD 1971 FOR VISUAL DEVICES)
NFPA 80 STANDARD FOR FIRE DOORS AND OTHER OPENING PROTECTIVES, 2016 ED.
NFPA 2001 STANDARD FOR CLEAN AGENT FIRE EXTINGUISHING SYSTEMS 2015 ED.
NFPA 300 STANDARD FOR FIRE TESTING OF FIRE EXTINGUISHING SYSTEMS FOR PROTECTION OF COMMERCIAL COOKING EQUIPMENT, 2005 (2010)
UL 464 AUDIBLE SIGNALING DEVICES FOR FIRE ALARM AND SIGNALING SYSTEMS, INCLUDING ACCESSORIES, 20013 ED.
UL 521 STANDARD FOR HEAT DETECTORS FOR FIRE PROTECTIVE SIGNALING SYSTEMS, 1999 ED.
UL 1971 STANDARD FOR SIGNALING DEVICES FOR THE HEARING IMPAIRED, 2002 ED.
ICC 300 STANDARD FOR BLEACHERS, FOLDING AND TELESCOPING SEATING AND GRANDSTANDS, 2012 ED.

FOR A COMPLETE LIST OF APPLICABLE NFPA STANDARDS REFER TO 2016 CBC (SFM) CHAPTER 35 AND CALIFORNIA FIRE CODE CHAPTER 80.

SEE CALIFORNIA BUILDING CODE, CHAPTER 35, FOR STATE OF CALIFORNIA AMENDMENTS TO THE NFPA STANDARDS.

AMERICANS WITH DISABILITIES ACT TITLE II, REGULATIONS 28 CFR PART 35, 2010 ADA STANDARDS FOR ACCESSIBLE DESIGN

2018 CITY OF SAN DIEGO STANDARD DRAWINGS FOR PUBLIC WORKS CONSTRUCTION

*ALL PARTS OF THE 2016 CALIFORNIA BUILDING CODE BECOME EFFECTIVE JANUARY 1, 2017 EXCEPT THE EFFECTIVE DATE FOR THE USE OF THE 2016 BUILDING ENERGY EFFICIENCY STANDARDS (TITLE 24, PART 1, CHAPTER 10) IS FEBRUARY 25, 2016 AND THE EFFECTIVE DATE FOR THE USE OF THE CALIFORNIA ADMINISTRATIVE CODE (TITLE 24, PART 1, CHAPTER 24) IS JANUARY 20, 2016.

BUILDING DATA

PROPOSED USE: RESTROOM/STORAGE/CONCESSIONS
OCCUPANCY GROUP: B
CONSTRUCTION TYPE: V-B
STORIES, ALLOWED: 2
STORIES, ACTUAL: 1
BUILDING HEIGHT, ALLOWED: 40 FEET
BUILDING HEIGHT, ACTUAL: 15'-1"
AREA PER FLOOR, ALLOWED: 9,000 SF
AREA PER FLOOR, ACTUAL: 2,385 GSF
OCCUPANTS, DESIGN LOAD: 5
FIRE SUPPRESSION SYSTEM: NO
PORTABLE FIRE EXTINGUISHERS: YES
FIRE RESISTANCE RATING FOR BUILDING ELEMENTS:
STRUCTURAL FRAME: 0
BEARING WALLS: 0
NON-BEARING WALLS, INTERIOR: 0
FLOOR CONSTRUCTION: 0
ROOF CONSTRUCTION: 0
SHAFT ENCLOSURES: N/A
STAIRWAY ENCLOSURES: N/A
CORRIDOR: N/A
FIRE RESISTANCE RATING REQUIREMENTS FOR EXTERIOR WALLS BASED ON FIRE SEPARATION DISTANCE:
X > 5 FEET 1 HR
5 ≤ X ≤ 10 FEET 1 HR
10 ≤ X ≤ 30 FEET 0 HR
X ≥ 30 FEET 0 HR

OWNER/APPLICANT

ARCHITECT:
CITY OF SAN DIEGO
PUBLIC WORKS / ENGINEERING AND CAPITAL PROJECTS DEPARTMENT
YOVANNA LEWIS
525 B STREET, SUITE 750
SAN DIEGO, CA 92101
T: (619) 533-5130

PROJECT TEAM

ARCHITECT:
MANUEL ONCINA ARCHITECTS, INC.
5711 LA JOLLA BLVD.
LA JOLLA, CA 92037
T: (858) 459-1221
F: (858) 459-1214
CONTACT: PATRICK BANNING
PBANNING@ONCINAARC.COM

STRUCTURAL ENGINEER:
ORION STRUCTURAL ENGINEERING, INC.
11305 RANCHO BERNARDO RD. SUITE 121
SAN DIEGO, CA 92127
T: (858) 679-1974
F: (858) 679-1975
CONTACT: RYAN OMER
RYAN@ORIONSE.COM

MECHANICAL ENGINEER:
T-SQUARED PROFESSIONAL ENGINEERS, INC.
1340 SPECIALTY DR. SUITE E
VISTA, CA 92081
T: (760) 560-0100
F: (760) 560-0101
CONTACT: GRACE ZEELIG
GRACE.ZEELIG@SALASOBIEN.COM

ELECTRICAL ENGINEER:
T-SQUARED PROFESSIONAL ENGINEERS, INC.
1340 SPECIALTY DR. SUITE E
VISTA, CA 92081
T: (760) 560-0100
F: (760) 560-0101
CONTACT: GRACE ZEELIG
GRACE.ZEELIG@SALASOBIEN.COM

PLUMBING ENGINEER:
T-SQUARED PROFESSIONAL ENGINEERS, INC.
1340 SPECIALTY DR. SUITE E
VISTA, CA 92081
T: (760) 560-0100
F: (760) 560-0101
CONTACT: GRACE ZEELIG
GRACE.ZEELIG@SALASOBIEN.COM

CIVIL ENGINEER:
RICK ENGINEERING COMPANY
5620 FRIARS RD.
SAN DIEGO, CA 92110
T: (619) 291-0707
F: (619) 291-4165
CONTACT: KAREN VAN ERT, P.E.
KVANERT@RICKENGINEERING.COM

LANDSCAPE:
RICK ENGINEERING COMPANY
5620 FRIARS RD.
SAN DIEGO, CA 92110
T: (619) 291-0707
F: (619) 291-4165
CONTACT: TIMOTHY PRUSS, ASLA
TPRUS@RICKENGINEERING.COM

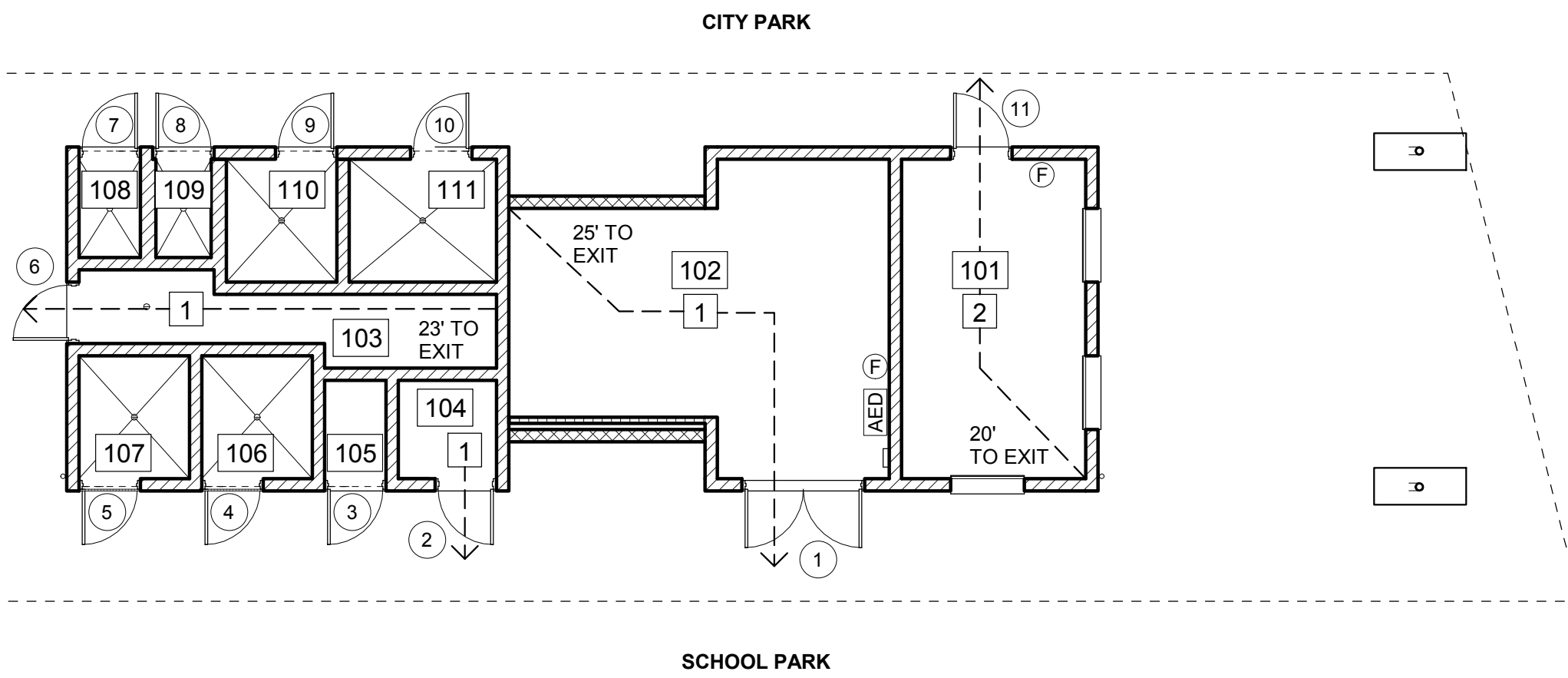

EGRESS DIAGRAM 1
1/8" = 1'-0"

SYMBOL LEGEND

- # ROOM OCCUPANT LOAD
- # ACCUMULATED EXITING LOAD
- INTENDED EGRESS ROUTE
- ←--- EXIT
- # EXIT OPENING
- F FIRE EXTINGUISHER CLASS 4A-20B.C
- AED AED DEVICE IN CABINET

ROOM EXITING ANALYSIS

#	ROOM NAME	AREA	LOAD FACTOR	OCCUPANT LOAD	# OF REQUIRED EXITS	EXIT WIDTH FACTOR (INCHES)	EXIT WIDTH REQUIRED (INCHES)
101	CONCESSION ROOM	173 SF	100 GROSS	2	1	0.2	0.4
102	STORAGE ROOM	290 SF	300 GROSS	1	1	0.2	0.2
103	PLUMBING CHASE	83 SF	300 GROSS	1	1	0.2	0.2
104	ELECTRICAL ROOM	28 SF	300 GROSS	1	1	0.2	0.2

EXIT SCHEDULE

Door #	EXITING ROOM	EXITING LOAD	EXIT WIDTH FACTOR (INCHES)	EXIT WIDTH REQUIRED (INCHES)	EXIT WIDTH PROVIDED (INCHES)	REMARKS
1	STORAGE ROOM	2	0.2	0.4	36	
2	ELECTRICAL ROOM	1	0.2	0.2	36	
6	PLUMBING CHASE	1	0.2	0.2	36	
11	CONCESSION ROOM	1	0.2	0.2	36	

SHEET LIST, SCOPE, SITE PLAN REFERENCES

SHEET LIST: REFER TO SHEET G-2 (SET SHEET No. 3-D)
SCOPE OF WORK/ WORK TO BE DONE: REFER TO SHEET G-1 (SET SHEET No. 2-D)
SITE PLAN: REFER TO SHEET G-7 (SET SHEET No. 8-D)
DEFERRED SUBMITTALS: NONE

FIRE ALARM EXEMPTION NOTE

THIS PROJECT IS EXEMPT FROM THE GREEN OAKS FAMILY ACADEMY ELEMENTARY SCHOOL FIRE PROTECTION ACT (SB 575, CHAPTER 725, STATUTES OF 2001), A LETTER FROM DAVID KOEPPKE (DISTRICT ARCHITECT) TO CRAIG RUSH (REGIONAL MANAGER, DIVISION OF THE STATE ARCHITECT) DATED APRIL 11, 2019, IS ON FILE WITH DSA CONFIRMING THE EXEMPTION.

CONCESSIONS ROOM NOTE

THE CONCESSIONS ROOM/FACILITY WILL BE 100% PRE-PACKAGED FOOD ONLY.

DISTRICT'S UNIQUE BUILDING IDENTIFIER

THIS BUILDING WILL BE IDENTIFIED AS "04-11" IN THE WANGENHEIM MIDDLE SCHOOL CAMPUS.

STATEMENT OF GENERAL CONFORMANCE

FOR ARCHITECTS/ENGINEERS WHO UTILIZE PLANS, INCLUDING BUT NOT LIMITED TO SHOP DRAWINGS, PREPARED BY OTHER LICENSED DESIGN PROFESSIONALS AND/OR CONSULTANTS.

(APPLICATION NO. 04-118244 FILE NO. 33-59)

THE DRAWINGS OR SHEETS LISTED ON SHEET G-2 THIS DRAWING, PAGE OF SPECIFICATIONS/CALCULATIONS

HAVE BEEN PREPARED BY OTHER DESIGN PROFESSIONALS OR CONSULTANTS WHO ARE LICENSED AND/OR AUTHORIZED TO PREPARE SUCH DRAWINGS IN THE STATE. IT HAS BEEN EXAMINED BY ME FOR:

- DESIGN INTENT AND APPEARS TO MEET THE APPROPRIATE REQUIREMENTS OF TITLE 24, CALIFORNIA CODE OF REGULATIONS AND THE PROJECT SPECIFICATIONS PREPARED BY ME, AND
- COORDINATION WITH MY PLANS AND SPECIFICATIONS AND IS ACCEPTABLE FOR INCORPORATION INTO THE CONSTRUCTION OF THIS PROJECT.

THE STATEMENT OF GENERAL CONFORMANCE "SHALL NOT BE CONSTRUED AS RELIEVING ME OF MY RIGHTS, DUTIES AND RESPONSIBILITIES UNDER SECTIONS 17306 AND 81138 OF THE EDUCATION CODE AND SECTIONS 4-336, 4-431 AND 4-344" OF TITLE 24, PART 1. (TITLE 24, PART 1, SECTION 4-317 [b])

I CERTIFY THAT:
 ALL CIVIL, LANDSCAPE, STRUCTURAL, MECHANICAL, PLUMBING, ELECTRICAL AND SHADE STRUCTURE SHEETS.
 IS/ARE IN GENERAL CONFORMANCE AND HAVE BEEN COORDINATED

SIGNATURE: *J. Manuel Oncina* DATE: 7/18/2019
ARCHITECT OR ENGINEER DESIGNATED TO BE IN GENERAL RESPONSIBLE CHARGE.

J. MANUEL ONCINA
PRINT NAME

C 13996 RENEWAL DATE: 2/28/2021
LICENSE NUMBER

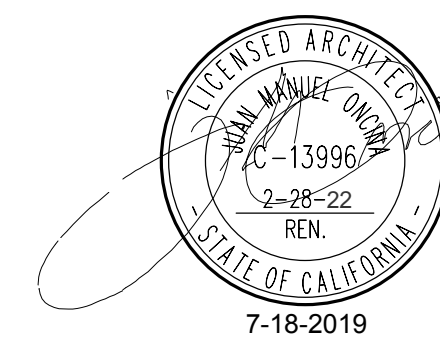

MANUEL ONCINA ARCHITECTS INC. ARCHITECTURE PLANNING INTERIORS
5711 La Jolla Blvd
La Jolla, CA 92037
Tel: 858/459-1221
Fax: 858/459-1214
www.oncinaarc.com

WANGENHEIM NEIGHBORHOOD JOINT USE FACILITY ARCHITECTURAL TITLE SHEET

CITY OF SAN DIEGO, CALIFORNIA
PUBLIC WORKS DEPARTMENT
SHEET 1 OF 142 SHEETS
WBS S-15007

APPROVED:	DATE	PROJECT MANAGER	DATE	PROJECT MANAGER
<i>Jason Grani</i>	10-13-20	YOVANNA LEWIS	77208	YOVANNA LEWIS
FOR CITY ENGINEER		JASON GRANI		JASON GRANI
PRINT NAME		RC#		RC#
DESCRIPTION	BY	APPROVED	DATE	FILMED
ORIGINAL				
ADDENDUM C	REC	<i>J. Grani</i>	1/28/2021	
				DATE STARTED
				DATE COMPLETED



CONTRACTOR INSPECTOR

AT-1

- CONSTRUCTION NOTES:**
- ① PROPOSED 24" NDS SQUARE BRASS GRATE
 - ② PROPOSED 12" CLEANOUT PER SDSW-101 SEE DETAIL ON SHEET C-26/C
 - ③ CONNECT PROPOSED TYPE I CATCH BASIN TO EXIST. 12" STORM DRAIN
 - ④ PROPOSED TYPE I CATCH BASIN PER D-29, SEE SHT. C-28
 - ⑤ PROPOSED TYPE A-4 CLEANOUT PER D-9, SEE SHT. C-28
 - ⑥ CONNECT PROPOSED TYPE A-4 CLEANOUT TO EXIST. 12" STORM DRAIN
 - ⑦ CONNECT PROPOSED STORM DRAIN TO EXIST. CATCH BASIN
 - ⑧ CONNECT TYPE I CATCH BASIN TO EXIST. 15" STORM DRAIN
 - ⑨ PROPOSED 24" X 24" CATCH BASIN
 - ⑩ FOR BASIN I CROSS SECTION SEE SHEET C-26
 - ⑪ CONNECT 4" SEWER LATERAL TO EXISTING SEWER MANHOLE
 - ⑫ SEE DETAIL SDSW-101 SHEET C-26
 - ⑬ SEE DETAIL SDSW-102 SHEET C-26
 - ⑭ SEE DETAIL SDSW-103 SHEET C-26
 - ⑮ SEE BMP CROSS-SECTION SHEET C-26
 - ⑯ 6" LANDSCAPE COBBLE (RIP-RAP) WITH 8" COBBLE ROCK, 4' X 6'
 - ⑰ DIP WATER UNDER PROPOSED STORM DRAIN
 - ⑱ EXISTING CATCH BASIN BURIED PER DEMO PLANS. SEE SHEET D-1 FOR DETAIL
 - ⑲ PROPOSED TRENCH RESURFACING PER SDG-107, SEE SHT. C-28
 - ⑳ PROPOSED TYPE B INLET PER STD. DWG SDD-116, SEE SHT. C-28

IDENTIFICATION STAMP
 DIV. OF THE STATE ARCHITECT
 APP. 04-118244 INC.
 REVIEWED FOR
 SS FLS ACS
 DATE: 02.14.2020

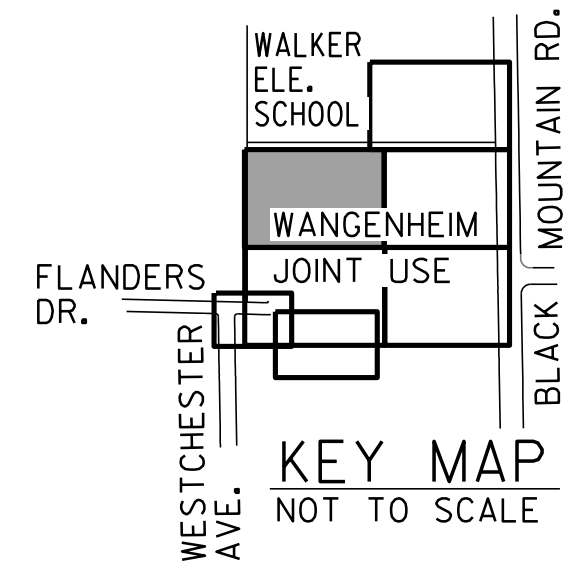

STORM DRAIN DATA				
NO.	DELTA OR BRG.	RADIUS	LENGTH	REMARKS
①	N00° 20'10"E		47.15'	8" PVC @ 0.5%
②	N90° 00'00"W		19.40'	8" PVC @ 2.5%
③	N00° 00'00"W		118.45'	8" PVC @ 0.5%
④	N44° 25'05"E		80.30'	8" PVC @ 0.5%
⑤	N89° 22'31"E		63.34'	8" PVC @ 1.9%
⑥	N89° 13'42"E		57.88'	8" PVC @ 5.2%
⑦	N89° 05'37"E		68.93'	8" PVC @ 2.2%



IMPORTANT NOTICE
 SECTION 4215/4217 OF THE GOVERNMENT CODE REQUIRES A DIG ALERT IDENTIFICATION NUMBER BE ISSUED BEFORE A "PERMIT TO EXCAVATE" WILL BE VALID. FOR YOUR DIG ALERT I.D. NUMBER, CALL UNDERGROUND SERVICE ALERT TOLL FREE 1-800-422-4133 AT LEAST TWO WORKING DAYS BEFORE YOU DIG.

C-7

WANGERHEIM NEIGHBORHOOD JOINT USE FACILITY
UTILITY PLAN

CITY OF SAN DIEGO, CALIFORNIA
 PUBLIC WORKS DEPARTMENT
 SHEET 21 OF 142 SHEETS

WBS S-15007

APPROVED: *Jason Grani* 10-13-20
 FOR CITY ENGINEER JASON GRANI DATE 7/20/20
 PRINT NAME RCE#

SUBMITTED BY: YOVANNA LEWIS PROJECT MANAGER
 CHECKED BY: MEHDI RASHIDPOUR-HARISH PROJECT ENGINEER

DESCRIPTION	BY	APPROVED	DATE	FILMED
ORIGINAL				
ADDENDUM C	REC	<i>SS</i>	1/28/2021	

DATE STARTED: _____ DATE COMPLETED: _____

CONTRACTOR: _____ INSPECTOR: _____

40846-21-D

WATER DATA				
NO.	DELTA OR BRG.	RADIUS	LENGTH	REMARKS
①	N45° 00'00"E		92.05'	3" PVC

EXISTING UTILITIES NOTE:
 ALL EXISTING UTILITIES SHOWN ON THESE PLANS ARE PLOTTED FROM RECORD DATA AT THEIR APPROXIMATE LOCATIONS. UNDERGROUND FACILITIES MAY EXIST WHICH HAVE NOT BEEN REPORTED OR ARE NOT OF RECORD. CONTRACTOR SHALL VERIFY THE LOCATION OF ALL PERTINENT UTILITIES IN THE FIELD PRIOR TO THE START OF CONSTRUCTION.

RICK ENGINEERING COMPANY
 5620 FRIARS ROAD
 SAN DIEGO, CA 92110
 619-291-0707
 (FAX) 619-291-4165
 rickengineering.com
 San Diego Riverside - Orange - Sacramento - San Luis Obispo - Phoenix - Tucson - Denver

J-17721

NOTE: FOR ROUGH GRADING, SEE SHEET

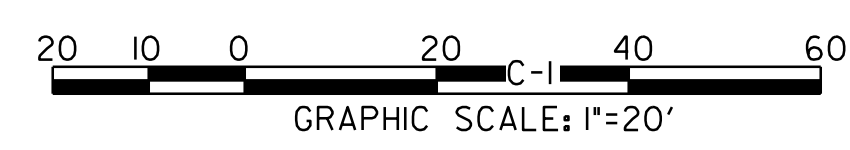

Karen S. Van Ert
 KAREN S. VAN ERT R.C.E. 56991 EXP. 6-30-2021
 DATE 10-15-2019



SEE SHEET C-8

MATCHLINE - SEE SHEET C-7

MATCHLINE - SEE SHEET C-11

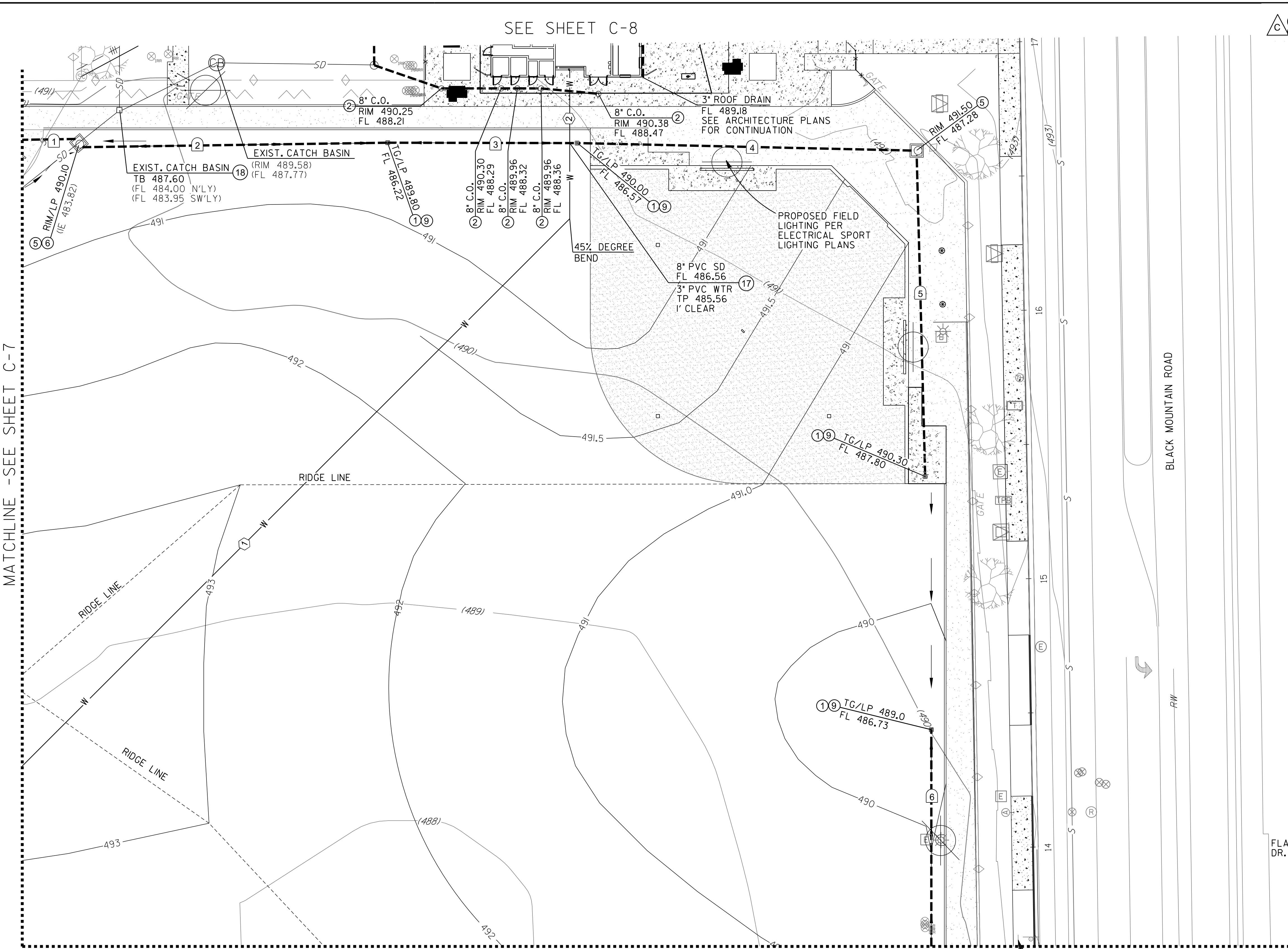

CONSTRUCTION NOTES:

- PROPOSED 24" NDS SQUARE BRASS GRATE
- PROPOSED 12" CLEANOUT PER SDSW-101 SEE DETAIL ON SHEET C-26
- CONNECT PROPOSED TYPE I CATCH BASIN TO EXIST. 12" STORM DRAIN
- PROPOSED TYPE I CATCH BASIN PER D-29. SEE SHT. C-28
- PROPOSED TYPE A-4 CLEANOUT PER D-9. SEE SHT. C-28
- CONNECT PROPOSED TYPE A-4 CLEANOUT TO EXIST. 12" STORM DRAIN
- CONNECT PROPOSED STORM DRAIN TO EXIST. CATCH BASIN
- CONNECT TYPE I CATCH BASIN TO EXIST. 15" STORM DRAIN
- PROPOSED 24" X 24" CATCH BASIN
- FOR BASIN I CROSS SECTION SEE SHEET C-26
- CONNECT 4" SEWER LATERAL TO EXISTING SEWER MANHOLE
- SEE DETAIL SDSW-101 SHEET C-26
- SEE DETAIL SDSW-102 SHEET C-26
- SEE DETAIL SDSW-103 SHEET C-26
- SEE BMP CROSS-SECTION SHEET C-26
- 6" LANDSCAPE COBBLE (RIP-RAP) WITH 8" COBBLE ROCK, 4' W X 6' L
- PROPOSED 18" X 18" CATCH BASIN
- EXISTING CATCH BASIN BURIED PER DEMO PLANS. SEE SHEET D-3
- PROPOSED TRENCH RESURFACING PER SDG-107. SEE SHT. C-28
- PROPOSED TYPE B INLET PER STD. DWG SDD-116. SEE SHT. C-28

IDENTIFICATION STAMP
 DIV. OF THE STATE ARCHITECT
 APP. 04-118244 INC.
 REVIEWED FOR
 SS FLS ACS
 DATE: 02.14.2020

STORM DRAIN DATA				
NO.	DELTA OR BRG.	RADIUS	LENGTH	REMARKS
1	N89° 05' 36" E		19.84'	8" PVC @ 2.2%
2	N89° 09' 40" E		113.68'	8" PVC @ 2.1%
3	N89° 53' 05" W		69.78'	8" PVC @ 0.5%
4	N90° 00' 00" W		123.78'	8" PVC @ 0.5%
5	N00° 00' 00" E		118.56'	8" PVC @ 0.5%
6	N00° 00' 00" E		80.73'	12" PVC @ 0.5%

WATER DATA				
NO.	DELTA OR BRG.	RADIUS	LENGTH	REMARKS
1	N45° 00' 00" E		288.28'	3" PVC
2	N00° 00' 00" W		55.43'	3" PVC

EXISTING UTILITIES NOTE:
 ALL EXISTING UTILITIES SHOWN ON THESE PLANS ARE PLOTTED FROM RECORD DATA AT THEIR APPROXIMATE LOCATIONS. UNDERGROUND FACILITIES MAY EXIST WHICH HAVE NOT BEEN REPORTED OR ARE NOT OF RECORD. CONTRACTOR SHALL VERIFY THE LOCATION OF ALL PERTINENT UTILITIES IN THE FIELD PRIOR TO THE START OF CONSTRUCTION.



CALL 811 BEFORE YOU DIG

IMPORTANT NOTICE
 SECTION 4215/4217 OF THE GOVERNMENT CODE REQUIRES A DIG ALERT IDENTIFICATION NUMBER BE ISSUED BEFORE A "PERMIT TO EXCAVATE" WILL BE VALID. FOR YOUR DIG ALERT I.D. NUMBER, CALL UNDERGROUND SERVICE ALERT TOLL FREE 1-800-422-4133 AT LEAST TWO WORKING DAYS BEFORE YOU DIG.

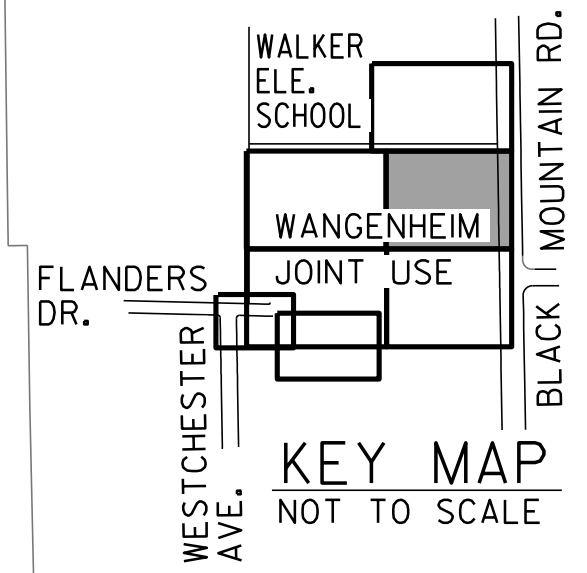

WANGENHEIM NEIGHBORHOOD JOINT USE FACILITY

UTILITY PLAN

CITY OF SAN DIEGO, CALIFORNIA
 PUBLIC WORKS DEPARTMENT
 SHEET 23 OF 142 SHEETS

APPROVED:	DATE:	FOR CITY ENGINEER:	DATE:	PROJECT MANAGER:
JASON GRANI	10-13-20	JASON GRANI	7/20/08	YOVANNA LEWIS
DESCRIPTION:	BY:	APPROVED:	DATE:	FILMED:
ORIGINAL	REC		1/28/2021	
ADDENDUM C				
DATE STARTED:				270-1731
DATE COMPLETED:				CCS27 COORDINATE
				1910-6291
				CCS83 COORDINATE
CONTRACTOR INSPECTOR:				40846-23-D

RICK ENGINEERING COMPANY
 5620 FRIARS ROAD
 SAN DIEGO, CA 92110
 619-291-0707
 (FAX) 619-291-4165
 J-17721
 rickengineering.com
 San Diego Riverside - Orange - Sacramento - San Luis Obispo - Phoenix - Tucson - Denver

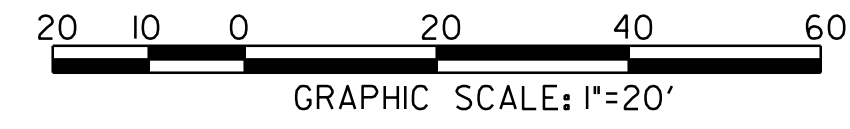

CAUTION: ! 3" HP GAS !
 CONTRACTOR TO VERIFY EXACT LOCATION AND MUST NOTIFY SDG&E IN ADVANCE PRIOR TO EXCAVATION. SDG&E STAND BY REQUIRED.

KAREN S. VAN ERT
 R.C.E. 56991
 EXP. 6-30-2021



10-15-2019 DATE
 10/15/2019

MATCHLINE - SEE SHEET C-7

WATER DATA				
NO.	DELTA OR BRG.	RADIUS	LENGTH	REMARKS
1	N90° 00'00"E		1.00'	3" PVC
2	N00° 00'00"W		5.00'	3" PVC
3	N90° 00'00"E		14.80'	3" PVC
4	N45° 00'00"E		259.00'	3" PVC

RECYCLED WATER DATA				
NO.	DELTA OR BRG.	RADIUS	LENGTH	REMARKS
5	N62° 01'42"E		6.29'	3" PVC
6	N27° 58'18"E		10.36'	3" PVC
7	N27° 58'18"E		10.36'	3" PVC

- CONSTRUCTION NOTES:**
- PROPOSED 24" NDS SQUARE BRASS GRATE
 - PROPOSED 12" CLEANOUT PER SDSW-101 SEE DETAIL ON SHEET C-26
 - CONNECT PROPOSED TYPE I CATCH BASIN TO EXIST. 12" STORM DRAIN
 - PROPOSED TYPE I CATCH BASIN PER D-29, SEE SHT. C-28
 - PROPOSED TYPE A-4 CLEANOUT PER D-9, SEE SHT. C-28
 - CONNECT PROPOSED TYPE A-4 CLEANOUT TO EXIST. 12" STORM DRAIN
 - CONNECT PROPOSED STORM DRAIN TO EXIST. CATCH BASIN
 - CONNECT TYPE I CATCH BASIN TO EXIST. 15" STORM DRAIN
 - PROPOSED 24" X 24" CATCH BASIN
 - FOR BASIN I CROSS SECTION SEE SHEET C-26
 - CONNECT 4" SEWER LATERAL TO EXISTING SEWER MANHOLE
 - SEE DETAIL SDSW-101 SHEET C-26
 - SEE DETAIL SDSW-102 SHEET C-26
 - SEE DETAIL SDSW-103 SHEET C-26
 - SEE BMP CROSS-SECTION SHEET C-26
 - 6" LANDSCAPE COBBLE (RIP-RAP) WITH 8" COBBLE ROCK, 4'W X 6'L
 - PROPOSED 18"X18" CATCH BASIN
 - EXISTING CATCH BASIN BURIED PER DEMO PLANS. SEE SHEET D-4
 - PROPOSED TRENCH RESURFACING PER SDG-107, SEE SHT. C-28
 - PROPOSED TYPE B INLET PER STD. DWG SDD-116, SEE SHT. C-28

IDENTIFICATION STAMP
 DIV. OF THE STATE ARCHITECT
 APP. 04-118244 INC.
 REVIEWED FOR
 SS FLS ACS
 DATE: 02.14.2020

EXIST. 1" POTABLE WATER METER TO BE UPSIZED TO 1-1/2" POTABLE WATER METER FOR CONCESSION STAND SOURCING

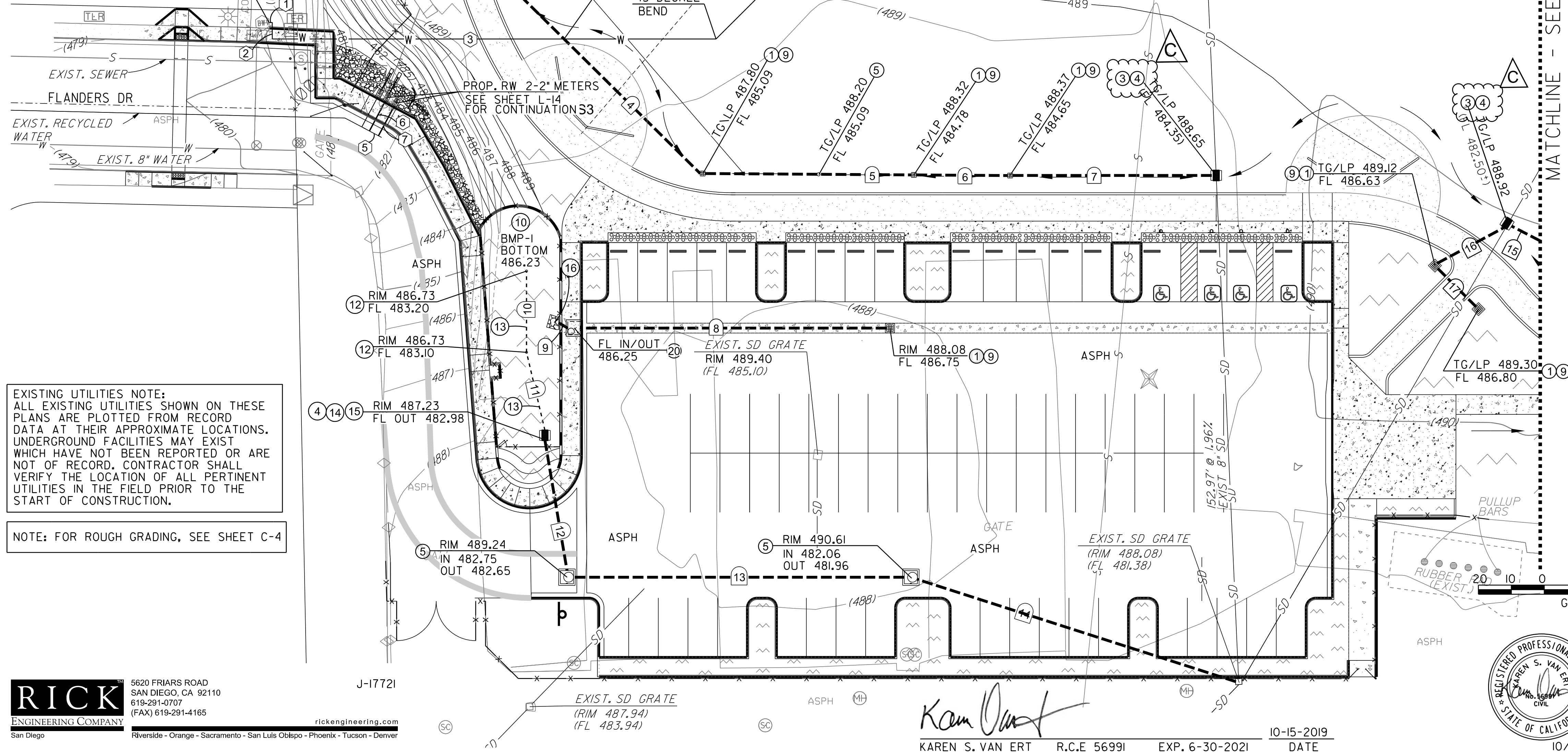

STORM DRAIN DATA				
NO.	DELTA OR BRG.	RADIUS	LENGTH	REMARKS
1	N90° 00'00"E		17.90'	8" PVC @ 0.6%
2	N02° 12'31"W		63.36'	8" PVC @ 0.5%
3	N02° 12'31"W		83.20'	8" PVC @ 0.5%
4	N58° 32'35"W		81.5'	12" PVC @ 0.5%
5	S89° 37'45"E		62.64'	12" PVC @ 0.5%
6	S89° 37'45"E		27.76'	12" PVC @ 0.5%
7	N90° 00'00"E		60.85'	12" PVC @ 0.5%
8	N90° 00'00"W		92.62'	12" PVC @ 0.5%
9	N59° 39'14"W		3.19'	12" PVC @ 0.5%
10	N00° 00'00"E		24.71'	8" PVC @ 0.4%
11	N12° 44'18"W		24.38'	8" PVC @ 0.5%
12	N9° 36'29"W		40.12'	8" PVC @ 0.59%
13	N90° 00'00"W		100.47'	12" PVC @ 0.59%
14	N72° 10'04"W		101.64'	12" PVC @ 0.9%
15	N62° 39'04"W		9.77'	12" PVC @ 0.5%
16	N61° 51'16"E		23.12'	8" PVC @ 17.8%
17	N45° 00'00"W		16.68'	8" PVC @ 1.0%

EXISTING UTILITIES NOTE:
 ALL EXISTING UTILITIES SHOWN ON THESE PLANS ARE PLOTTED FROM RECORD DATA AT THEIR APPROXIMATE LOCATIONS. UNDERGROUND FACILITIES MAY EXIST WHICH HAVE NOT BEEN REPORTED OR ARE NOT OF RECORD. CONTRACTOR SHALL VERIFY THE LOCATION OF ALL PERTINENT UTILITIES IN THE FIELD PRIOR TO THE START OF CONSTRUCTION.

NOTE: FOR ROUGH GRADING, SEE SHEET C-4

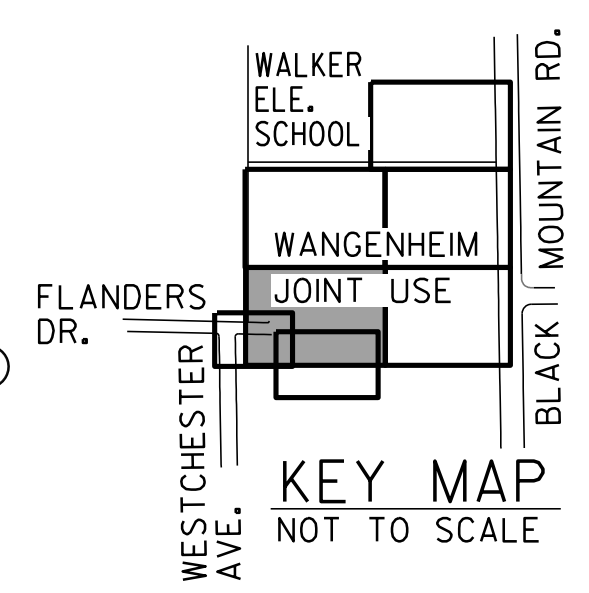

IMPORTANT NOTICE
 SECTION 4215/4217 OF THE GOVERNMENT CODE REQUIRES A DIG ALERT IDENTIFICATION NUMBER BE ISSUED BEFORE A "PERMIT TO EXCAVATE" WILL BE VALID. FOR YOUR DIG ALERT I.D. NUMBER, CALL UNDERGROUND SERVICE ALERT TOLL FREE 1-800-422-4133 AT LEAST TWO WORKING DAYS BEFORE YOU DIG.



WANGENHEIM NEIGHBORHOOD JOINT USE FACILITY
UTILITY PLAN

CITY OF SAN DIEGO, CALIFORNIA PUBLIC WORKS DEPARTMENT SHEET 24 OF 142 SHEETS		WBS S-15007
APPROVED: <i>[Signature]</i> FOR CITY ENGINEER JASON GRANI PRINT NAME DATE: 10-13-20 77208 RCE#	SUBMITTED BY: YOVANNA LEWIS PROJECT MANAGER CREATED BY: MEHDI RASHIDPOUR-HARISI PROJECT ENGINEER	
DESCRIPTION	BY	APPROVED
ORIGINAL		
ADDENDUM C	REC	1/28/2021
		270-1731
		1910-6291
		CCS83 COORDINATE
CONTRACTOR INSPECTOR		DATE STARTED
		DATE COMPLETED
		40846-24-D

RICK ENGINEERING COMPANY
 5620 FRIARS ROAD
 SAN DIEGO, CA 92110
 619-291-0707
 (FAX) 619-291-4165
 rickengineering.com
 Riverside - Orange - Sacramento - San Luis Obispo - Phoenix - Tucson - Denver

[Signature]
 KAREN S. VAN ERT R.C.E 56991 EXP. 6-30-2021
 DATE 10-15-2019



MATCHLINE - SEE SHEET C-9

CONSTRUCTION NOTES:

- 1 PROPOSED 24" NDS SQUARE BRASS GRATE
- 2 PROPOSED 12" CLEANOUT PER SDSW-101 SEE DETAIL ON SHEET C-26
- 3 CONNECT PROPOSED TYPE I CATCH BASIN TO EXIST. 12" STORM DRAIN
- 4 PROPOSED TYPE I CATCH BASIN PER D-29. SEE SHT. C-28
- 5 PROPOSED TYPE A-4 CLEANOUT PER D-9. SEE SHT. C-28
- 6 CONNECT PROPOSED TYPE A-4 CLEANOUT TO EXIST. 12" STORM DRAIN
- 7 CONNECT PROPOSED STORM DRAIN TO EXIST. CATCH BASIN
- 8 CONNECT TYPE I CATCH BASIN TO EXIST. 15" STORM DRAIN
- 9 PROPOSED 24" X 24" CATCH BASIN
- 10 FOR BASIN I CROSS SECTION SEE SHEET C-26
- 11 CONNECT 4" SEWER LATERAL TO EXISTING SEWER MANHOLE
- 12 SEE DETAIL SDSW-101 SHEET C-26
- 13 SEE DETAIL SDSW-102 SHEET C-26
- 14 SEE DETAIL SDSW-103 SHEET C-26
- 15 SEE BMP CROSS-SECTION SHEET C-26
- 16 6" LANDSCAPE COBBLE (RIP-RAP) WITH 8" COBBLE ROCK, 4'W X 6'L
- 17 PROPOSED 18"X18" CATCH BASIN
- 18 EXISTING CATCH BASIN BURIED PER DEMO PLANS. SEE SHEET D-5
- 19 PROPOSED TRENCH RESURFACING PER SDG-107. SEE SHT. C-28
- 20 PROPOSED TYPE B INLET PER STD. DWG SDD-116. SEE SHT. C-28

IDENTIFICATION STAMP
 DIV. OF THE STATE ARCHITECT
 APP. 04-118244 INC.
 REVIEWED FOR
 SS FLS ACS
 DATE: 02.14.2020

MATCHLINE - SEE SHEET C-10

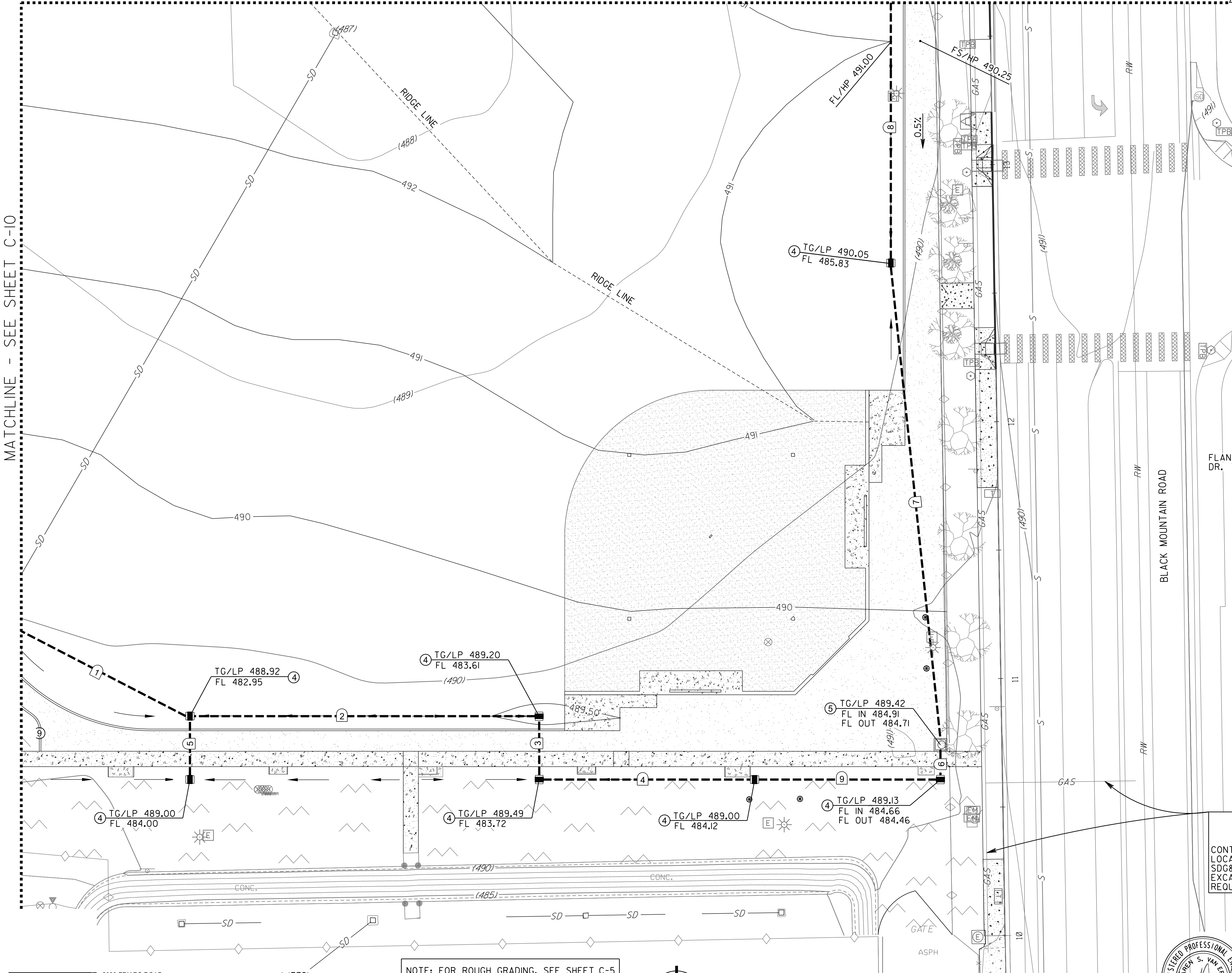

STORM DRAIN DATA				
NO.	DELTA OR BRG.	RADIUS	LENGTH	REMARKS
1	N62° 39'04"W		72.05'	I2" PVC @ 0.5%
2	S89° 59'36"W		132.76'	I2" PVC @ 0.5%
3	N00° 03'46"W		21.32'	I2" PVC @ 0.5%
4	N00° 00'00"E		80.67'	I2" PVC @ 0.5%
5	N00° 00'00"E		21.66'	I2" PVC @ 4.8%
6	N00° 00'00"E		10.54'	I2" PVC @ 0.5%
7	S05° 59'51"E		184.97'	I2" PVC @ 0.5%
8	N00° 00'00"E		99.77'	I2" PVC @ 0.5%
9	N00° 00'00"E		69.19'	I2" PVC @ 0.5%

WATER DATA				
NO.	DELTA OR BRG.	RADIUS	LENGTH	REMARKS
1	Δ=14° 33'46"	350.00'	88.96'	3" PVC

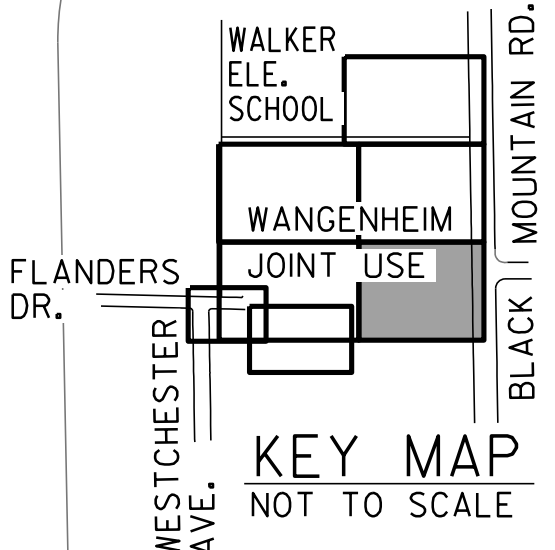

EXISTING UTILITIES NOTE:
 ALL EXISTING UTILITIES SHOWN ON THESE PLANS ARE PLOTTED FROM RECORD DATA AT THEIR APPROXIMATE LOCATIONS. UNDERGROUND FACILITIES MAY EXIST WHICH HAVE NOT BEEN REPORTED OR ARE NOT OF RECORD. CONTRACTOR SHALL VERIFY THE LOCATION OF ALL PERTINENT UTILITIES IN THE FIELD PRIOR TO THE START OF CONSTRUCTION.



CALL 811 BEFORE YOU DIG

IMPORTANT NOTICE
 SECTION 4215/4217 OF THE GOVERNMENT CODE REQUIRES A DIG ALERT IDENTIFICATION NUMBER BE ISSUED BEFORE A "PERMIT TO EXCAVATE" WILL BE VALID. FOR YOUR DIG ALERT I.D. NUMBER, CALL UNDERGROUND SERVICE ALERT TOLL FREE 1-800-422-4133 AT LEAST TWO WORKING DAYS BEFORE YOU DIG.

CAUTION: !3" HP GAS!
 CONTRACTOR TO VERIFY EXACT LOCATION AND MUST NOTIFY SDG&E IN ADVANCE PRIOR TO EXCAVATION. SDG&E STAND BY REQUIRED.

RICK ENGINEERING COMPANY
 5620 FRIARS ROAD
 SAN DIEGO, CA 92110
 619-291-0707
 (FAX) 619-291-4165
 rickengineering.com
 Riverside - Orange - Sacramento - San Luis Obispo - Phoenix - Tucson - Denver

NOTE: FOR ROUGH GRADING, SEE SHEET C-5
 GRAPHIC SCALE: 1"=20'

KAREN S. VAN ERT
 R.C.E. 56991
 EXP. 6-30-2021

10-15-2019
 DATE

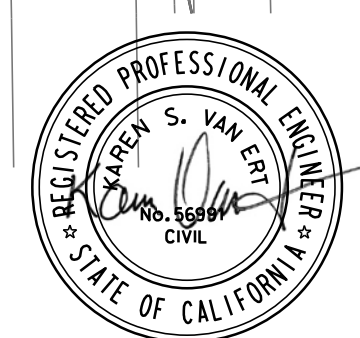

WANGENHEIM NEIGHBORHOOD JOINT USE FACILITY
UTILITY PLAN
 CITY OF SAN DIEGO, CALIFORNIA
 PUBLIC WORKS DEPARTMENT
 SHEET 25 OF 142 SHEETS
 WBS S-15007

APPROVED FOR CITY ENGINEER	DATE	10-13-20	77208
JASON GRANI	DATE	77208	
PRINT NAME	RCE#		

DESCRIPTION	BY	APPROVED	DATE	FILMED
ORIGINAL				
ADDENDUM C	REC			

CONTRACTOR INSPECTOR: _____ DATE STARTED: _____ DATE COMPLETED: _____

40846-25-D

Bid Results

Bidder Details

Vendor Name Tri-Group Construction & Development, Inc.
 Address 9580 Black Mountain Rd, Ste L
 San Diego, California 92126
 United States
 Respondee Hani Assi
 Respondee Title Secretary of Corporation
 Phone 858-689-0058
 Email hani@trigroupinc.com
 Vendor Type CADIR, PQUAL, SLBE
 License # 792159
 CADIR 1000004777

Bid Detail

Bid Format Electronic
 Submitted 02/17/2021 1:52 PM (PST)
 Delivery Method
 Bid Responsive
 Bid Status Submitted
 Confirmation # 243231
 Ranking 0

Respondee Comment

Buyer Comment

Bond

eBond Contract ID

Attachments

File Title	File Name	File Type
Wangenheim Bid Bond.pdf	Wangenheim Bid Bond.pdf	Bid Bond
Wangenheim - Subcontractors Debarment and Suspension Certification.pdf	Wangenheim - Subcontractors Debarment and Suspension Certification.pdf	General Attachments
Wangenheim Certification of Pending Actions.pdf	Wangenheim Certification of Pending Actions.pdf	General Attachments
Wangenheim - Business Interest Disclosure.pdf	Wangenheim - Business Interest Disclosure.pdf	General Attachments
Wangenheim - Debarment and Suspension Certification.pdf	Wangenheim - Debarment and Suspension Certification.pdf	General Attachments

Subcontractors

Showing 12 of undefined Subcontractors

Name & Address	Desc	License Num	CADIR	Amount	Type
Ace Electric, Inc. PO Box 601071 San Diego, California 92160	Constructor Electrical	835109	1000001519	\$976,500.00	PQUAL
Crafters Fence, Inc 9510 Pathway Street suite B Santee, California 92071	Constructor Backstops, Fence, and Gates	815320	1000014084	\$256,850.00	
G. Scott Asphalt, INC 358 TROUSDALE DRIVE CHULA VISTA, CA, California 9191	Constructor Asphalt Paving & Slurry Seal	751836	1000004252	\$92,277.00	DVBE, SDB
INDEPTH ENVIRONMENTAL INC 3954 MURPHY CANYON RD STE San Diego, California 92123	Designer MEC/UXO Services with certified UXO technician Munition & Explosives Concern	1057467	1000708200	\$50,000.00	
Luber Mechanical 13250 Creek Park In. Poway, California 92064	Constructor Mechanical work	910942	100018260	\$11,479.00	
MTGL Inc. 6295 Ferris Square, Suite C San Diego, California 92121	Designer Soil Inspection & Testing	000000	1000006646	\$136,857.00	LAT, FEM, DBE, HUBZ, MBE, CADIR, SDB, WBE, WOSB
PGC Construction, Inc 42309 Winchester Rd Suite C Temecula, California 92591	Constructor Roofing, Soffit, & Downspouts	829086	1000036314	\$99,900.00	
Precision Striping, Inc. 4580 Alvarado Canyon Rd. San Diego, California 92021	Constructor Striping	1026547	1000051515	\$3,950.00	CADIR, DBE, ELBE, LAT, MALE, SDB
SpectraTurf 555 S. Promenade Avenue Suite #103 Corona, California 92879	Constructor Resilient Surfacing Repair	854429	1000002615	\$4,800.00	CADIR
Vasquez Construction Company 3009 G Street San Diego, California 92102	Constructor Painting & Anti- Graffiti Coating	560999	1000002710	\$38,000.00	
Vortex Industries 20 Odyssey Irvine, California 92618	Constructor Doors	287885	1000002841	\$54,058.00	CAU, FEM, WBE
Weber's Plumbing 33345 Fowler Driver PO Box 549 Winchester, California 92596	Constructor Plumbing	444338	1000017279	\$95,000.00	DVBE, SDB

Line Items

Item #	Item Code	Section	Type	Item Description	UOM	QTY	Unit Price	Line Total	Response	Comment
1	524126	Main Bid		Bonds (Payment and Performance)	LS	1	\$80,000.00	\$80,000.00	Yes	
2	236220	Main Bid		Building Permits (EOC Type I)	AL	1	\$12,000.00	\$12,000.00	Yes	
3	237310	Main Bid		Specialty Inspection Paid for by the Contractor (EOC Type I)	AL	1	\$10,000.00	\$10,000.00	Yes	
4	238990	Main Bid		Construction for Wangenheim Neighborhood Park Joint Use Facility	LS	1	\$5,900,000.00	\$5,900,000.00	Yes	
5	236220	Main Bid		Mobilization	LS	1	\$200,000.00	\$200,000.00	Yes	
6	238990	Main Bid		Munition of Explosive Concern	LS	1	\$80,000.00	\$80,000.00	Yes	
7		Main Bid		Field Orders (EOC Type II)	AL	1	\$300,000.00	\$300,000.00	Yes	
8	541330	Main Bid		Traffic Control and Working Drawings	LS	1	\$80,000.00	\$80,000.00	Yes	
9	238210	Main Bid		SDG&E Service Orders (EOC Type I)	AL	1	\$10,000.00	\$10,000.00	Yes	
10	541330	Main Bid		SWPPP Development	LS	1	\$80,000.00	\$80,000.00	Yes	
11	237310	Main Bid		SWPPP Implementation	LS	1	\$80,000.00	\$80,000.00	Yes	
12	541330	Main Bid		SWPPP Permit Fee (EOC Type I)	AL	1	\$2,000.00	\$2,000.00	Yes	

Line Item Subtotals

Section Title	Line Total
Main Bid	\$6,834,000.00
Grand Total	\$6,834,000.00

Line Totals (Unit Price * Quantity)								
Item Num	Section	Item Code	Description	Reference	Unit of Measure	Quantity	Tri-Group Construction & Development, Inc. - Unit Price	Tri-Group Construction & Development, Inc. - Line Total
1	Main Bid	524126	Bonds (Payment and Performance)	1-7.2.1	LS	1	\$80,000.00	\$80,000.00
2	Main Bid	236220	Building Permits (EOC Type I)	2-2.3	AL	1	\$12,000.00	\$12,000.00
3	Main Bid	237310	Specialty Inspection Paid for by the Contractor (EOC Type I)	4-3.4.1	AL	1	\$10,000.00	\$10,000.00
4	Main Bid	238990	Construction for Wangenheim Neighborhood Park Joint Use Facility	7-3.1	LS	1	\$5,900,000.00	\$5,900,000.00
5	Main Bid	236220	Mobilization	7-3.4.1	LS	1	\$200,000.00	\$200,000.00
6	Main Bid	238990	Munition of Explosive Concern	APPENDIX I	LS	1	\$80,000.00	\$80,000.00
7	Main Bid		Field Orders (EOC Type II)	7-3.9	AL	1	\$300,000.00	\$300,000.00
8	Main Bid	541330	Traffic Control and Working Drawings	601-7	LS	1	\$80,000.00	\$80,000.00
9	Main Bid	238210	SDG&E Service Orders (EOC Type I)	701-2	AL	1	\$10,000.00	\$10,000.00

10	Main Bid	541330	SWPPP Development	1001-3.7	LS	1	\$80,000.00	\$80,000.00
11	Main Bid	237310	SWPPP Implementation	1001-3.7	LS	1	\$80,000.00	\$80,000.00
12	Main Bid	541330	SWPPP Permit Fee (EOC Type I)	1001-3.7	AL	1	\$2,000.00	\$2,000.00
							Subtotal	\$6,834,000.00
							Total	\$6,834,000.00