

# City of San Diego

**CONTRACTOR'S NAME:** J.R. FILANC CONSTRUCTION COMPANY, INC. \_\_\_\_\_

**ADDRESS:** 740 North Andreasen Drive, Escondido, CA 92029 \_\_\_\_\_

**TELEPHONE NO.:** 760-691-9143 **FAX NO.:** 760-941-3969 \_\_\_\_\_

**CITY CONTACT:** Juan E. Espindola, Contract Specialist, Email: JEEspindola@sandiego.gov \_\_\_\_\_

Phone No. (619) 533-4491, Fax No. (619) 533-3633 \_\_\_\_\_

J.Arcillas / J. Borja / mlw

**CONTRACT  
DOCUMENTS**

**ORIGINAL**



**FOR**

**EMERGENCY CONSTRUCTION SERVICES FOR:  
STORM DRAIN AT 5914 AGEE STREET (UNIVERSITY CITY SOUTH STORM DRAIN  
REPLACEMENT)**

RFQ NO.: \_\_\_\_\_ **5753** \_\_\_\_\_

BID NO.: \_\_\_\_\_ **K-18-1602-EMR-1** \_\_\_\_\_

SAP NO. (WBS/IO/CC): \_\_\_\_\_ **B-16173** \_\_\_\_\_

CLIENT DEPARTMENT: \_\_\_\_\_ **2116** \_\_\_\_\_

COUNCIL DISTRICT: \_\_\_\_\_ **1** \_\_\_\_\_

PROJECT TYPE: \_\_\_\_\_ **CA** \_\_\_\_\_

**ENGINEER OF WORK**

The engineering Specifications and Special Provisions contained herein have been prepared by or under the direction of the following Registered Engineer:

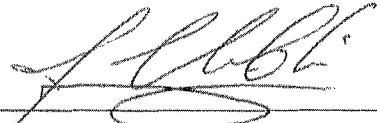
  
\_\_\_\_\_  
For City Engineer

8/2/17  
\_\_\_\_\_  
Date

Seal:

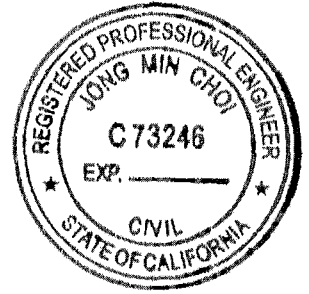

## TABLE OF CONTENTS

<b>DESCRIPTION</b>	<b>PAGE NUMBER</b>
1. GENERAL .....	4
2. AGREEMENT .....	11
3. EXHIBITS	
• Exhibit A – Drug-Free Workplace Certification .....	17
• Exhibit B – ADA Compliance Certification .....	19
• Exhibit C – Contractor Standards - Pledge of Compliance .....	21
• Exhibit D – Affidavit of Disposal .....	23
• Exhibit E – Non-Collusion Affidavit .....	25
• Exhibit F – Contractors Certification of Pending Actions .....	27
• Exhibit G – Equal Benefits Ordinance Certification of Compliance .....	29
• Exhibit H – Forms .....	31
• Exhibit I – Supplementary Special Provisions .....	34
• Exhibit J – Proposal .....	48
• Exhibit K – Contractor’s Compensation Rate Schedule .....	52
• Exhibit L – Notice of Exemption .....	54
• Exhibit M – Location Map .....	57
• Exhibit N - Storm Water Applicability Checklist (DS-560) .....	59
• Exhibit O - Advanced Metering Infrastructure (AMI) Device Protection .....	64

## CITY OF SAN DIEGO, CALIFORNIA

### GENERAL

#### 1. DESCRIPTION OF WORK:

- 1.1. The Work involves furnishing all labor, materials, equipment, services, and other incidental works and appurtenances for the purpose of designing and constructing this emergency project at the direction of the City Engineer.
- 1.2. The Work consists of repair and reconstruction of a sinkhole caused by a deteriorating storm drain. Repairs at 5914 Agee Street will include, but is not limited to, temporarily filling the void and plating the hole, a new clean out north of the sink hole, replace approximately 30 linear feet of 24 inch CMP with 24 inch reinforced concrete pipe (RCP) storm drain. All replacement will occur within the existing alignment (previously disturbed soils). The sink hole will be filled to pre-emergency grade and compaction. The contractor will be tasked with diverting any storm water flow throughout the duration of repair work.
- 1.3. This solicitation is for a "Time-and-Materials" contract in accordance with the provisions set forth in 3-2.4, "Agreed Prices" of The GREENBOOK.
- 1.4. A time-and-materials contract provides for acquiring labor, material, equipment and services that shall be paid for in accordance with 3-3, "EXTRA WORK" of The GREENBOOK and as modified by The WHITEBOOK.

#### 2. CONTRACTOR REGISTRATION AND ELECTRONIC REPORTING SYSTEM:

- 2.1. **Prior** to the Award of the Contract or each Task Order, the Contractor must comply with the following registration requirements:
  - 2.1.1. This project is subject to compliance monitoring and enforcement by the California Department of Industrial Relations (DIR). **Contractor and Subcontractor Registration Requirements** for compliance with those requirements are outlined in paragraph 7.9 of these "General" Instructions.
  - 2.1.2. In addition, prior to award of the Contract or each Task Order, the Contractor and its Subcontractors and Suppliers **must** register with Prism®, the City's web-based contract compliance portal at:  
  
<https://pro.prismcompliance.com/default.aspx>.
  - 2.1.3. The City may not award the contract until registration of all subcontractors and suppliers is complete. In the event this requirement is not met within the time frame specified in the Notice of Intent to Award letter, the City reserves the right to rescind the Notice of Award /

Intent to Award and to make the award to the next responsive and responsible bidder / proposer.

**3. EQUAL OPPORTUNITY.**

**3.1.** For the City's Equal Opportunity Program requirements see Part 10 of the City of San Diego 2015 Whitebook and Exhibit I Supplementary Special Provisions.

**4. CONTRACT TIME:** The Work shall be completed within **60 Working Days** from the date of issuance of the Notice to Proceed.

**5. CONTRACT PRICE:** The Engineer's Estimate of the Contract Price is **\$200,000**. The Contractor shall not perform Work that exceeds the Engineer's Estimate excluding Allowances without prior written notice from the City that sufficient additional funding has been secured.

**6. CONTRACTOR'S LICENSE CLASSIFICATION:** In accordance with the provisions of California Law, the Contractor shall possess valid appropriate license(s) at the time of award. The City has determined the following licensing classification for this contract: **Class A**.

**7. PREVAILING WAGE RATES:** Pursuant to San Diego Municipal Code section 22.3019, construction, alteration, demolition, repair and maintenance work performed under this Contract is subject to State prevailing wage laws. For construction work performed under this Contract cumulatively exceeding \$25,000 and for alteration, demolition, repair and maintenance work performed under this Contract cumulatively exceeding \$15,000, the Contractor and its subcontractors shall comply with State prevailing wage laws including, but not limited to, the requirements listed below.

**7.1. Compliance with Prevailing Wage Requirements.** Pursuant to sections 1720 through 1861 of the California Labor Code, the Contractor and its subcontractors shall ensure that all workers who perform work under this Contract are paid not less than the prevailing rate of per diem wages as determined by the Director of the California Department of Industrial Relations (DIR). This includes work performed during the design and preconstruction phases of construction including, but not limited to, inspection and land surveying work.

**7.1.1.** Copies of such prevailing rate of per diem wages are on file at the City and are available for inspection to any interested party on request. Copies of the prevailing rate of per diem wages also may be found at <http://www.dir.ca.gov/OPRL/DPreWageDetermination.htm>. Contractor and its subcontractors shall post a copy of the prevailing rate of per diem wages determination at each job site and shall make them available to any interested party upon request.

**7.1.2.** The wage rates determined by the DIR refer to expiration dates. If the published wage rate does not refer to a predetermined wage rate to be paid after the expiration date, then the published rate of wage shall be in effect for the life of this Contract. If the published wage rate refers to a predetermined wage rate to become effective upon expiration of the published wage rate and the predetermined wage rate is on file with the DIR, such predetermined wage rate shall become effective on the date following the expiration date and shall apply to this Contract in the same manner as if it had been published in said publication. If the predetermined wage rate refers to one or more additional expiration dates with additional predetermined wage rates, which expiration dates occur during the life of this Contract, each successive predetermined wage rate shall apply to this Contract on the date following the expiration date of the previous wage rate. If the last of such predetermined wage rates expires during the life of this Contract, such wage rate shall apply to the balance of the Contract.

**7.2. Penalties for Violations.** Contractor and its subcontractors shall comply with California Labor Code section 1775 in the event a worker is paid less than the prevailing wage rate for the work or craft in which the worker is employed.

**7.3. Payroll Records.** Contractor and its subcontractors shall comply with California Labor Code section 1776, which generally requires keeping accurate payroll records, verifying and certifying payroll records, and making them available for inspection. Contractor shall require its subcontractors to also comply with section 1776. Contractor and its subcontractors shall submit weekly certified payroll records online via the City's web-based Labor Compliance Program. Contractor is responsible for ensuring its subcontractors submit certified payroll records to the City.

**7.3.1.** For contracts entered into on or after April 1, 2015, Contractor and their subcontractors shall furnish records specified in Labor Code section 1776 directly to the Labor Commissioner in the manner required by Labor Code section 1771.4.

**7.4. Apprentices.** Contractor and its subcontractors shall comply with California Labor Code sections 1777.5, 1777.6 and 1777.7 concerning the employment and wages of apprentices. Contractor is held responsible for the compliance of their subcontractors with sections 1777.5, 1777.6 and 1777.7.

**7.5. Working Hours.** Contractor and their subcontractors shall comply with California Labor Code sections 1810 through 1815, including but not limited to: (i) restrict working hours on public works contracts to eight hours a day and forty hours a week, unless all hours worked in excess of 8 hours per day are compensated at not less than 1½ times the basic rate of pay; and (ii) specify penalties to be imposed on design professionals and subcontractors of \$25 per worker per day for each day the worker works more than 8 hours per day and 40 hours per week in violation of California Labor Code sections 1810 through 1815.

- 7.6. Required Provisions for Subcontracts.** Contractor shall include at a minimum a copy of the following provisions in any contract they enter into with a subcontractor: California Labor Code sections 1771, 1771.1, 1775, 1776, 1777.5, 1810, 1813, 1815, 1860 and 1861.
- 7.7. Labor Code Section 1861 Certification.** Contractor in accordance with California Labor Code section 3700 is required to secure the payment of compensation of its employees and by signing this Contract, Contractor certifies that "I am aware of the provisions of Section 3700 of the California Labor Code which require every employer to be insured against liability for workers' compensation or to undertake self-insurance in accordance with the provisions of that code, and I will comply with such provisions before commencing the performance of the work of this Contract."
- 7.8. Labor Compliance Program.** The City has its own Labor Compliance Program authorized in August 2011 by the DIR. The City will withhold contract payments when payroll records are delinquent or deemed inadequate by the City or other governmental entity, or it has been established after an investigation by the City or other governmental entity that underpayment(s) have occurred. For questions or assistance, please contact the City of San Diego's Equal Opportunity Contracting Department at 619-236-6000.
- 7.9. Contractor and Subcontractor Registration Requirements.** This project is subject to compliance monitoring and enforcement by the DIR. As of March 1, 2015, no contractor or subcontractor may be listed on a bid or proposal for a public works project unless registered with the DIR pursuant to Labor Code section 1725.5. As of April 1, 2015, a contractor or subcontractor shall not be qualified to bid on, be listed in a bid proposal, or enter into any contract for public work, unless currently registered and qualified to perform public work pursuant to Labor Code section 1725.5. By submitting a bid or proposal to the City, Contractor is certifying that he or she has verified that all subcontractors used on this public work project are registered with the DIR in compliance with Labor Code sections 1771.1 and 1725.5, and Contractor shall provide proof of registration to the City upon request.
- 7.9.1.** A Contractor's inadvertent error in listing a subcontractor who is not registered pursuant to Labor Code section 1725.5 in response to a solicitation shall not be grounds for filing a bid protest or grounds for considering the bid non-responsive provided that any of the following apply: (1) the subcontractor is registered prior to bid opening; (2) within twenty-four hours after the bid opening, the subcontractor is registered and has paid the penalty registration fee specified in Labor Code section 1725.5; or (3) the subcontractor is replaced by another registered subcontractor pursuant to Public Contract Code section 4107.

8. **REFERENCE STANDARDS:** Except as otherwise noted or specified, the Work shall be completed in accordance with the following standards:

Title	Edition	Document Number
Standard Specifications for Public Works Construction ("The GREENBOOK") <a href="http://www.greenbookspecs.org/">http://www.greenbookspecs.org/</a>	2015	PWPI070116-01
City of San Diego Standard Specifications for Public Works Construction ("The WHITEBOOK")* <a href="https://www.sandiego.gov/publicworks/edocref/greenbook">https://www.sandiego.gov/publicworks/edocref/greenbook</a>	2015	PWPI070116-02
City of San Diego Standard Drawings* <a href="https://www.sandiego.gov/publicworks/edocref/standarddraw">https://www.sandiego.gov/publicworks/edocref/standarddraw</a>	2016	PWPI070116-03
Citywide Computer Aided Design and Drafting (CADD) Standards <a href="https://www.sandiego.gov/publicworks/edocref/drawings">https://www.sandiego.gov/publicworks/edocref/drawings</a>	2016	PWPI092816-04
California Department of Transportation (CALTRANS) Standard Specifications - <a href="http://www.dot.ca.gov/des/oe/construction-contract-standards.html">http://www.dot.ca.gov/des/oe/construction-contract-standards.html</a>	2015	PWPI092816-05
CALTRANS Standard Plans - <a href="http://www.dot.ca.gov/des/oe/construction-contract-standards.html">http://www.dot.ca.gov/des/oe/construction-contract-standards.html</a>	2015	PWPI092816-06
California Manual on Uniform Traffic Control Devices Revision 1 (CA MUTCD Rev 1) - <a href="http://www.dot.ca.gov/trafficops/camutcd/">http://www.dot.ca.gov/trafficops/camutcd/</a>	2014	PWPI092816-07
<b>NOTE:</b> *Available online under Engineering Documents and References at: <a href="http://www.sandiego.gov/publicworks/edocref/index.shtml">http://www.sandiego.gov/publicworks/edocref/index.shtml</a>		

9. **INSURANCE REQUIREMENTS:**

- 9.1. All certificates of insurance and endorsements required by the contract are to be provided upon issuance of the City's Notice of Intent to Award letter.
- 9.2. Refer to sections 7-3, "LIABILITY INSURANCE", and 7-4, "WORKERS' COMPENSATION INSURANCE" of the Supplementary Special Provisions (SSP) for the Insurance requirements which must be met.

10. **SUBMITTAL OF "OR EQUAL" ITEMS:** See 4-1.6, "Trade Names or Equals."

11. **SUBCONTRACT LIMITATIONS:** The Bidder's attention is directed to Standard Specifications for Public Works Construction, Section 2-3, "SUBCONTRACTS" which requires the Contractor to perform not less than the amount therein stipulated with its own forces. Failure to comply with these requirements shall render the Bid non-responsive and ineligible for award.



12. **PLANS AND SPECIFICATIONS:** When provided by the City, questions about the meaning or intent of the Contract Documents relating to the scope of Work and technical nature shall be directed to the City's Project Manager prior to commencement of work. Interpretations or clarifications considered necessary by the City in response to such questions will be issued in writing. Oral and other interpretations or clarifications will be without legal effect. Any questions related to this proposal shall be addressed to the, Public Works Contracts Branch, 1010 Second Avenue, Suite 1400, San Diego, California, 92101, Telephone No. (619) 533-3450.
13. **SAN DIEGO BUSINESS TAX CERTIFICATE:** All Contractors, including Subcontractors, not already having a City of San Diego Business Tax Certificate for the work contemplated shall secure the appropriate certificate from the City Treasurer, Civic Center Plaza, first floor, before the Contract can be executed.
14. **PROPOSAL FORMS:** The signature of each person signing may be in longhand or in electronic format as specified by the City. The Contractor shall furnish evidence of its corporate existence and evidence that the officer signing the Contract and bond for the corporation is duly authorized to do so.
15. **CITY'S RIGHTS RESERVED:** The City reserves the right to cancel this request for proposal at any time, and further reserves the right to reject submitted proposals, without giving any reason for such action, at its sole discretion and without liability. Costs incurred by the Contractor as a result of preparing its proposal shall be the sole responsibility of the Contractor.
16. **AWARD OF CONTRACT OR REJECTION OF PROPOSALS:**
  - 16.1. This contract may be awarded to a contractor selected from the City's as-needed emergency contractors list or may be awarded to another contractor in case the list of available emergency contractors list is exhausted.
  - 16.2. The City reserves the right to reject the proposal from the emergency list-selected contractor and request a proposal from the next contractor on the list when such rejection is in the best interests of the City.
17. **THE CONTRACT:** The Contractor shall execute a written contract with the City of San Diego and furnish good and approved bonds and insurance documents specified in 2-4, "CONTRACT BONDS," 7-3, "LIABILITY INSURANCE," and 7-4 WORKERS' COMPENSATION INSURANCE within **10 Working Days** after receipt by the Contractor of a form of contract for execution unless an extension of time is granted to the Contractor in writing. Bonds shall be in amount of the Contract Price for the Work included in the Bid.

The Contract shall be made in the form adopted by the City, which includes the provision that no claim or suit whatsoever shall be made or brought by Contractor against any officer, agent, or employee of the City for or on account of anything done or omitted to be done in connection with this contract, nor shall any such officer, agent, or employee be liable hereunder. If the Contractor fails to enter into the contract as herein provided, the award may be annulled. An award may be made to the next contractor on the shortlist or

in the case the emergency contractor's list is exhausted to any other responsive contractor on a sole-source basis who shall fulfill every stipulation embraced herein as if it were the party to whom the first award was made.

- 18. EXAMINATION OF PLANS, SPECIFICATIONS, AND SITE OF WORK:** The Contractor shall examine carefully the Project Site, the Plans and Specifications, other materials as described in the Special Provisions, Section 2-7, and the proposal forms. The signing of the Contract shall be conclusive evidence that the Contractor has investigated and is satisfied as to the conditions to be encountered, as to the character, quality, and scope of Work, the quantities of materials to be furnished, and as to the requirements of the Contract Documents.
  
- 19. CITY STANDARD PROVISIONS.** This contract is subject to the following standard provisions. See The WHITEBOOK for details.
  - 19.1.** The City of San Diego Resolution No. R-277952 adopted on May 20, 1991 for a Drug-Free Workplace.
  - 19.2.** The City of San Diego Resolution No. R-282153 adopted on June 14, 1993 related to the Americans with Disabilities Act.
  - 19.3.** The City of San Diego Municipal Code §22.3004 for Pledge of Compliance.
  - 19.4.** The City of San Diego's Labor Compliance Program and the State of California Labor Code §§1771.5(b) and 1776.
  - 19.5.** Sections 1777.5, 1777.6, and 1777.7 of the State of California Labor Code concerning the employment of apprentices by contractors and subcontractors performing public works contracts.
  - 19.6.** The City's Equal Benefits Ordinance (EBO), Chapter 2, Article 2, Division 43 of The San Diego Municipal Code (SDMC).
  - 19.7.** The City's Information Security Policy (ISP) as defined in the City's Administrative Regulation 90.63.

James Nagelvoort, Director  
Public Works Department

**AGREEMENT  
FOR  
EMERGENCY CONSTRUCTION SERVICES  
BETWEEN  
THE CITY OF SAN DIEGO  
AND  
J.R. FILANC CONSTRUCTION COMPANY, INC.**

---

This Emergency Construction Services Agreement (Agreement) is made and entered into by and between The City of San Diego (City), California a municipal corporation, and **J.R. FILANC CONSTRUCTION COMPANY, INC.** (Contractor), for the purpose of designing (when required) and performing emergency construction services at the direction of the City Engineer. The City and the Contractor are referred to herein as the "Parties."

**RECITALS**

- A. The City desires to construct the emergency project identified in Section 1, Description of Work.
- B. The City desires to contract with a single entity for Emergency Construction Services, as set forth in this agreement.
- C. The City had previously issued a Request for Qualifications (RFQ), via RFQ 5753, for on-call emergency construction services.
- D. In accordance with this RFQ, Contractors submitted Statements of Qualifications (SOQ) for these services from which the City established a pre-qualified list of the most highly qualified contractors to perform emergency construction services as directed by the City.
- E. In accordance with said RFQ, the Contractor submitted an SOQ and is prepared to enter into this agreement.
- F. The City has selected the Contractor from the City's list of on-call contractors to perform, either directly or with Subcontracts hereinafter defined, the design, engineering, and construction services set forth in this agreement and the Contract Documents.
- G. The Contractor is ready, willing, and able to perform the emergency construction services required as specified in the Scope of Work and Services section of this agreement and in accordance with the terms and conditions of this agreement and under the direction of the Engineer.

In consideration of the above recitals and the mutual covenants and conditions set forth herein, and for good and valuable consideration, the receipt and sufficiency of which are hereby acknowledged, the Parties hereby set forth their mutual covenants and understandings as follows:

## AGREEMENT

THE CITY OF SAN DIEGO, a municipal corporation, herein called "City", agrees to pay J.R. FILANC CONSTRUCTION COMPANY, INC., herein called "Contractor" for its time and materials used to construct **Storm Drain at 5914 Agee Street (University City South Storm Drain Replacement)**; in the amount not to exceed Two Hundred Thousand DOLLARS *00/100*.

- A. The following are incorporated into this contract as though fully set forth herein:
1. The attached Faithful Performance and Payment Bonds.
  2. The attached Proposal included in the Bid documents by the Contractor.
  3. Reference Standards listed in the General Instructions and the Supplementary Special Provisions (SSP).
  4. That certain documents entitled **Storm Drain at 5914 Agee Street (University City South Storm Drain Replacement)**, on file in the office of the Public Works Department as Document No. **B-16173**, as well as all matters referenced therein.
- B. The Contractor shall perform and be bound by all the terms and conditions of this contract and in strict conformity therewith shall perform and complete in a good and workmanlike manner **Storm Drain at 5914 Agee Street (University City South Storm Drain Replacement)**, Bid Number **K-18-1602-EMR-1**, San Diego, California.
- C. For such performances, the City shall pay to Contractor the amounts set forth at the times and in the manner and with such additions or deductions as are provided for in this contract, and the Contractor shall accept such payment in full satisfaction of all claims incident to such performances.
- D. No claim or suit whatsoever shall be made or brought by Contractor against any officer, agent, or employee of the City for or on account of anything done or omitted to be done in connection with this contract, nor shall any such officer, agent, or employee be liable hereunder.
- E. This contract is effective as of the date the City issued the Contractor a written notice to proceed (NTP), or the date of the last signatory below, whichever occurred first.
- F. The above referenced recitals are true and correct and are incorporated into this agreement by this reference.
- G. Exhibits referenced in this agreement are incorporated into the Agreement by this reference.
- H. The Contractor, including Subcontractors, not already having a City of San Diego Business Tax Certificate for the work contemplated shall secure the appropriate certificate from the City Treasurer, Civic Center Plaza, first floor, before the Agreement can be executed.

- I. Upon award, amendment, renewal, or extension of such contracts, the Contractors shall complete a Pledge of Compliance attesting under penalty of perjury that they complied with the requirements of City Municipal Code §22.3004.
- J. The Contractor shall ensure that all Subcontractors complete a Pledge of Compliance attesting under penalty of perjury that they complied with the requirements of this section. The Contractor shall include in each subcontract agreement, language which requires Subcontractors to abide by the provisions of City Municipal Code §22.3004. A sample provision is as follows:  
  
"Subcontractor acknowledges that it is familiar with the requirements of San Diego Municipal Code §22.3004 ("Contractor Standards"), and agrees to comply with requirements of that section. The Subcontractor further agrees to complete the Pledge of Compliance, incorporated herein by reference."
- K. Pledge of Compliance may be downloaded at:  
  
[http://www.sandiego.gov/purchasing/pdf/contractor\\_standards\\_questionnaire.pdf](http://www.sandiego.gov/purchasing/pdf/contractor_standards_questionnaire.pdf)
- L. The Contractor shall complete the work to be performed under this agreement and shall achieve Acceptance within the allowed number of Working Days from the NTP as specified in the Notice of Award, unless authorized otherwise by the Engineer. Time is of essence for the completion of the Work and the Project has critical milestones to be met as listed in the Notice of Award.
- M. During the final design process (if any), if the Contractor modifies the Project such that a revision of the environmental document is required, the Contractor shall be responsible for all work required for implementing a revision, including preparation of revised documentation and coordination with City staff. Work shall not proceed on the project until the environmental requirements are met to the satisfaction of the City. There shall be no additional time allowed in the contract for processing and approval of revised permit documents.
- N. Prior to NTP or as required by the City, the Contractor shall:
  - 1. File surety bonds with the City to be approved by the City in the amounts and for the purposes noted in the Notice Inviting Bids and
  - 2. Obtain the required insurance in accordance with 7-3, "LIABILITY INSURANCE" and any additional insurance as may be specified in the Supplemental Special Provisions.

**IN WITNESS WHEREOF**, this Agreement is executed by the City of San Diego, acting by and through its Mayor or designee, pursuant to the emergency contract provisions of City Charter §94 authorizing such execution, and by the Contractor.

**THE CITY OF SAN DIEGO**

**APPROVED AS TO FORM**

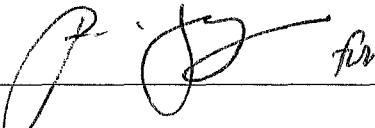
By   
Print Name: Juan E. Espindola  
Contract Specialist  
Public Works Department  
Date: 08/29/17

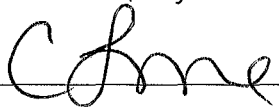
Mara W. Elliott, City Attorney  
By   
Print Name: Christopher Leone  
Deputy City Attorney  
Date: 8/30/17

**CONTRACTOR**

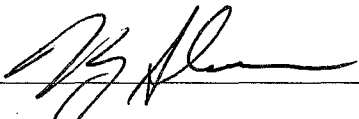
By   
Print Name: HARRY S. COSMOS  
Title: PRESIDENT  
Date: 8/16/2017  
City of San Diego License No.: B1994000641  
State Contractor's License No. : 134877

**AGREEMENT (continued)**  
**PERFORMANCE BOND AND LABOR AND MATERIALMEN'S BOND**

---

**FAITHFUL PERFORMANCE BOND AND LABOR AND MATERIALMEN'S BOND:**

J.R. FILANC CONSTRUCTION COMPANY, INC., a corporation, as principal, and Fidelity and Deposit Company of Maryland, a corporation authorized to do business in the State of California, as Surety, hereby obligate themselves, their successors and assigns, jointly and severally, to The City of San Diego a municipal corporation in the sum of **Two Hundred Thousand Dollars and Zero Cents (\$200,000.00)** for the faithful performance of the annexed contract, and in the sum of **Two Hundred Thousand Dollars and Zero Cents (\$200,000.00)** for the benefit of laborers and materialmen designated below.

**Conditions:**

If the Principal shall faithfully perform the annexed contract **Storm Drain at 5914 Agee Street (University City South Storm Drain Replacement)**, Bid Number **K-18-1602-EMR-1**, San Diego, California then the obligation herein with respect to a faithful performance shall be void; otherwise it shall remain in full force.

If the Principal shall promptly pay all persons, firms and corporations furnishing materials for or performing labor in the execution of this contract, and shall pay all amounts due under the California Unemployment Insurance Act then the obligation herein with respect to laborers and materialmen shall be void; otherwise it shall remain in full force.

The obligation herein with respect to laborers and materialmen shall inure to the benefit of all persons, firms and corporations entitled to file claims under the provisions of Article 2. Claimants, (iii) public works of improvement commencing with Civil Code Section 9100 of the Civil Code of the State of California.

Changes in the terms of the annexed contract or specifications accompanying same or referred to therein shall not affect the Surety's obligation on this bond, and the Surety hereby waives notice of same.

**AGREEMENT (continued)**  
**PERFORMANCE BOND AND LABOR AND MATERIALMEN'S BOND**

---

The Surety shall pay reasonable attorney's fees should suit be brought to enforce the provisions of this bond.

Dated August 18, 2017

Approved as to Form

J.R. Filanc Construction Company, Inc.

Principal

By [Signature]

Harry S. Caynes

Printed Name of Person Signing for  
Principal

Mara W. Elliott, City Attorney

By [Signature]  
Deputy City Attorney

Fidelity and Deposit Company of Maryland

Surety

By [Signature]  
Tara Bacon, Attorney-in-fact

Approved:

By [Signature]  
Juan E. Espindola, Contract Specialist  
Public Works Department

777 South Figueroa Street, Suite 3900

Local Address of Surety

Los Angeles, CA 90017

Local Address (City, State) of Surety

(213) 270-0804

Local Telephone No. of Surety

Premium \$1,981.00

Bond No. 9263651



**CALIFORNIA ALL-PURPOSE ACKNOWLEDGMENT**

**CIVIL CODE § 1189**

A notary public or other officer completing this certificate verifies only the identity of the individual who signed the document to which this certificate is attached, and not the truthfulness, accuracy, or validity of that document.

State of California  
County of San Diego)

On August 18, 2017 before me, Danyna Estee Alvarado, Notary Public  
(insert name and title of the officer)

personally appeared Tara Bacon  
who proved to me on the basis of satisfactory evidence to be the person(s) whose name(s) is/are subscribed to the within instrument and acknowledged to me that he/she/they executed the same in his/her/their authorized capacity(ies), and that by his/her/their signature(s) on the instrument the person(s), or the entity upon behalf of which the person(s) acted, executed the instrument.

I certify under PENALTY OF PERJURY under the laws of the State of California that the foregoing paragraph is true and correct.

WITNESS my hand and official seal.

Signature  (Seal)

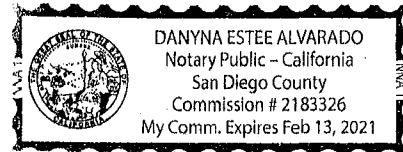

**ZURICH AMERICAN INSURANCE COMPANY  
COLONIAL AMERICAN CASUALTY AND SURETY COMPANY  
FIDELITY AND DEPOSIT COMPANY OF MARYLAND  
POWER OF ATTORNEY**

KNOW ALL MEN BY THESE PRESENTS: That the ZURICH AMERICAN INSURANCE COMPANY, a corporation of the State of New York, the COLONIAL AMERICAN CASUALTY AND SURETY COMPANY, a corporation of the State of Maryland, and the FIDELITY AND DEPOSIT COMPANY OF MARYLAND a corporation of the State of Maryland (herein collectively called the "Companies"), by **GERALD F. HALEY, Vice President**, in pursuance of authority granted by Article V, Section 8, of the By-Laws of said Companies, which are set forth on the reverse side hereof and are hereby certified to be in full force and effect on the date hereof, do hereby nominate, constitute, and appoint **Bradley R. ORR, Dale G. HARSHAW, Tara BACON, Kyle KING, John QUALIN and Minna HUOVILA, all of San Diego, California, EACH** its true and lawful agent and Attorney-in-Fact, to make, execute, seal and deliver, for, and on its behalf as surety, and as its act and deed: **any and all bonds and undertakings**, and the execution of such bonds or undertakings in pursuance of these presents, shall be as binding upon said Companies, as fully and amply, to all intents and purposes, as if they had been duly executed and acknowledged by the regularly elected officers of the ZURICH AMERICAN INSURANCE COMPANY at its office in New York, New York., the regularly elected officers of the COLONIAL AMERICAN CASUALTY AND SURETY COMPANY at its office in Owings Mills, Maryland., and the regularly elected officers of the FIDELITY AND DEPOSIT COMPANY OF MARYLAND at its office in Owings Mills, Maryland., in their own proper persons.

The said Vice President does hereby certify that the extract set forth on the reverse side hereof is a true copy of Article V, Section 8, of the By-Laws of said Companies, and is now in force.

IN WITNESS WHEREOF, the said Vice-President has hereunto subscribed his/her names and affixed the Corporate Seals of the said **ZURICH AMERICAN INSURANCE COMPANY, COLONIAL AMERICAN CASUALTY AND SURETY COMPANY, and FIDELITY AND DEPOSIT COMPANY OF MARYLAND**, this 13th day of December, A.D. 2016.

**ATTEST:**

**ZURICH AMERICAN INSURANCE COMPANY  
COLONIAL AMERICAN CASUALTY AND SURETY COMPANY  
FIDELITY AND DEPOSIT COMPANY OF MARYLAND**



By: 

*Secretary  
Michael McKibben*

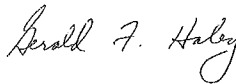

*Vice President  
Gerald F. Haley*

State of Maryland  
County of Baltimore

On this 13th day of December, A.D. 2016, before the subscriber, a Notary Public of the State of Maryland, duly commissioned and qualified, **GERALD F. HALEY, Vice President, and MICHAEL MCKIBBEN, Secretary**, of the Companies, to me personally known to be the individuals and officers described in and who executed the preceding instrument, and acknowledged the execution of same, and being by me duly sworn, depose and saith, that he/she is the said officer of the Company aforesaid, and that the seals affixed to the preceding instrument are the Corporate Seals of said Companies, and that the said Corporate Seals and the signature as such officer were duly affixed and subscribed to the said instrument by the authority and direction of the said Corporations.

IN TESTIMONY WHEREOF, I have hereunto set my hand and affixed my Official Seal the day and year first above written.

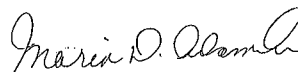

Maria D. Adamski, Notary Public  
My Commission Expires: July 8, 2019



**EXHIBIT A**

**DRUG-FREE WORKPLACE CERTIFICATION**

**EXHIBIT A**

**DRUG-FREE WORKPLACE**

**PROJECT TITLE: Storm Drain at 5914 Agee Street (University City South Storm Drain Replacement)**

---

I hereby certify that I am familiar with the requirements of San Diego City Council Policy No. 100-17 regarding Drug-Free Workplace as outlined in the WHITEBOOK, Section 7-13.3, "Drug-Free Workplace", of the project specifications, and that;

J.R. Filanc Construction Company, Inc.

(Name under which business is conducted)

has in place a drug-free workplace program that complies with said policy. I further certify that each subcontract agreement for this project contains language which indicates the subcontractor's agreement to abide by the provisions of subdivisions a) through c) of the policy as outlined.

Signed



Printed Name Harry S. Cosmos

Title President

**EXHIBIT B**

**AMERICAN WITH DISABILITIES ACT (ADA) COMPLIANCE CERTIFICATION**

**EXHIBIT B**

**AMERICAN WITH DISABILITIES ACT (ADA) COMPLIANCE CERTIFICATION**

**PROJECT TITLE: Storm Drain at 5914 Agee Street (University City South Storm Drain Replacement)**

I hereby certify that I am familiar with the requirements of San Diego City Council Policy No. 100-4 regarding the American With Disabilities Act (ADA) outlined in the WHITEBOOK, Section 7-13.2, "American With Disabilities Act", of the project specifications, and that;

J.R. Filanc Construction Company, Inc.

\_\_\_\_\_  
(Name under which business is conducted)

has in place workplace program that complies with said policy. I further certify that each subcontract agreement for this project contains language which indicates the subcontractor's agreement to abide by the provisions of the policy as outlined.

Signed \_\_\_\_\_

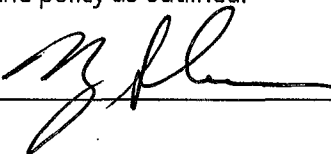

Printed Name Harry S. Cosmos

Title President

**EXHIBIT C**

**CONTRACTOR STANDARDS - PLEDGE OF COMPLIANCE**

**EXHIBIT C**

**CONTRACTOR STANDARDS - PLEDGE OF COMPLIANCE**

**PROJECT TITLE: Storm Drain at 5914 Agee Street (University City South Storm Drain Replacement)**

I declare under penalty of perjury that I am authorized to make this certification on behalf of J.R. Filanc Construction Company, Inc., as Contractor, that I am familiar with the requirements of City of San Diego Municipal Code § 22.3004 regarding Contractor Standards as outlined in the WHITEBOOK, Section 7-13.4, "Contractor Standards", of the project specifications, and that Contractor has complied with those requirements.

I further certify that each of the Contractor's subcontractors whose subcontracts are greater than \$50,000 in value has completed a Pledge of Compliance attesting under penalty of perjury of having complied with City of San Diego Municipal Code § 22.3004.

Dated this 17 Day of August, 2017.

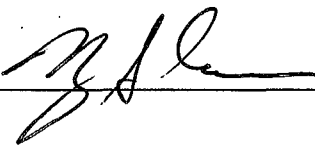
Signed  \_\_\_\_\_

Printed Name Harry S. Cosmos \_\_\_\_\_

Title President \_\_\_\_\_



**EXHIBIT D**

**AFFIDAVIT OF DISPOSAL**

**EXHIBIT D**

**AFFIDAVIT OF DISPOSAL**

**WHEREAS**, on the \_\_\_\_\_ DAY OF \_\_\_\_\_, \_\_\_\_\_, the undersigned entered into and executed a contract with the City of San Diego, a municipal corporation, for:

**Storm Drain at 5914 Agee Street (University City South Storm Drain Replacement)**

(Name of Project or Task)

as particularly described in said contract and identified as Bid No. **K-18-1602-EMR-1**; SAP No. (WBS/IO/CC) **B-16173**; and **WHEREAS**, the specification of said contract requires the Contractor to affirm that "all brush, trash, debris, and surplus materials resulting from this project have been disposed of in a legal manner"; and **WHEREAS**, said contract has been completed and all surplus materials disposed of:

\_\_\_\_\_  
\_\_\_\_\_  
\_\_\_\_\_

**NOW, THEREFORE**, in consideration of the final payment by the City of San Diego to said Contractor under the terms of said contract, the undersigned Contractor, does hereby affirm that all surplus materials as described in said contract have been disposed of at the following location(s)

\_\_\_\_\_  
\_\_\_\_\_  
\_\_\_\_\_

and that they have been disposed of according to all applicable laws and regulations.

Dated this \_\_\_\_\_ DAY OF \_\_\_\_\_, \_\_\_\_\_.

\_\_\_\_\_  
Contractor  
by

**ATTEST:**

State of \_\_\_\_\_  
County of \_\_\_\_\_

On this \_\_\_\_\_ DAY OF \_\_\_\_\_, 2\_\_\_\_, before the undersigned, a Notary Public in and for said County and State, duly commissioned and sworn, personally appeared \_\_\_\_\_ known to me to be the \_\_\_\_\_ Contractor named in the foregoing Release, and whose name is subscribed thereto, and acknowledged to me that said Contractor executed the said Release.

Notary Public in and for said County and State

**EXHIBIT E**

**NON-COLLUSION AFFIDAVIT TO BE EXECUTED BY BIDDER AND SUBMITTED WITH BID  
UNDER 23 UNITED STATES CODE 112 AND PUBLIC CONTRACT CODE 7106**

EXHIBIT E

NON-COLLUSION AFFIDAVIT TO BE EXECUTED BY BIDDER AND SUBMITTED WITH BID UNDER 23 UNITED STATES CODE 112 AND PUBLIC CONTRACT CODE 7106

State of California )  
County of San Diego ) ss.

Harry S. Cosmos, being first duly sworn, deposes and says that he or she is President of the party making the foregoing bid that the bid is not made in the interest of, or on behalf of, any undisclosed person, partnership, company, association, organization, or corporation; that the bid is genuine and not collusive or sham; that the bidder has not directly or indirectly induced or solicited any other bidder to put in a false or sham bid, and has not directly or indirectly colluded, conspired, connived, or agreed with any bidder or anyone else to put in a sham bid, or that anyone shall refrain from bidding; that the bidder has not in any manner, directly or indirectly, sought by agreement, communication, or conference with anyone to fix the bid price of the bidder or any other bidder, or to fix any overhead, profit, or cost element of the bid price, or of that of any other bidder, or to secure any advantage against the public body awarding the contract of anyone interested in the proposed contract; that all statements contained in the bid are true; and further, that the bidder has not, directly or indirectly, submitted his or her bid price or any breakdown thereof, or the contents thereof, or divulged information or data relative thereto, or paid, and will not pay, any fee to any corporation, partnership, company association, organization, bid depository, or to any member or agent thereof to effectuate a collusive or sham bid.

Signed: [Signature]  
Title: Harry S. Cosmos, President  
Subscribed and sworn to before me this \_\_\_\_\_ day of \_\_\_\_\_, 20\_\_

\_\_\_\_\_  
Notary Public  
(SEAL) See attached

A notary public or other officer completing this certificate verifies only the identity of the individual who signed the document to which this certificate is attached, and not the truthfulness, accuracy, or validity of that document.

State of California  
County of San Diego

Subscribed and sworn to (or affirmed) before me on this \_\_\_\_\_  
day of August 17, 2017, by Harry S. Cosmos

proved to me on the basis of satisfactory evidence to be the  
person(s) who appeared before me.

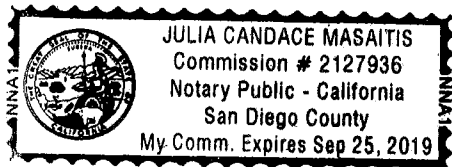

Signature Julia Candace Masaitis

**EXHIBIT F**

**CONTRACTORS CERTIFICATION OF PENDING ACTIONS**

**EXHIBIT F**

**CONTRACTORS CERTIFICATION OF PENDING ACTIONS**

As part of its bid or proposal (Non-Price Proposal In the case of Design-Build contracts), the Bidder shall provide to the City a list of all instances within the past ten years where a complaint was filed or pending against the Bidder in a legal or administrative proceeding alleging that Bidder discriminated against its employees, subcontractors, vendors or suppliers, and a description of the status or resolution of that complaint, including any remedial action taken.

CHECK ONE BOX ONLY.

- The undersigned certifies that within the past 10 years the Bidder has NOT been the subject of a complaint or pending action in a legal administrative proceeding alleging that Bidder discriminated against its employees, subcontractors, vendors or suppliers.
- The undersigned certifies that within the past 10 years the Bidder has been the subject of a complaint or pending action in a legal administrative proceeding alleging that Bidder discriminated against its employees, subcontractors, vendors or suppliers. A description of the status or resolution of that complaint, including any remedial action taken and the applicable dates is as follows:

DATE OF CLAIM	LOCATION	DESCRIPTION OF CLAIM	LITIGATION (Y/N)	STATUS	RESOLUTION/REMEDIAL ACTION TAKEN

Contractor Name: J.R. Filanc Construction Company, Inc.

Certified By Harry S. Cosmos Title President

 Name  
Signature Date 8/17/17

**USE ADDITIONAL FORMS AS NECESSARY**

**EXHIBIT G**

**EQUAL BENEFITS ORDINANCE CERTIFICATION OF COMPLIANCE**



**EXHIBIT G**

**EQUAL BENEFITS ORDINANCE  
CERTIFICATION OF COMPLIANCE**



For additional information, contact:  
**CITY OF SAN DIEGO**  
**EQUAL BENEFITS PROGRAM**  
 202 C Street, MS 9A, San Diego, CA 92101  
 Phone (619) 533-3948 Fax (619) 533-3220

COMPANY INFORMATION	
Company Name: J.R. Filanc Construction Company, Inc.	Contact Name: Harry S. Cosmos
Company Address: 740 N. Andreasen Drive Escondido, CA 92029	Contact Phone: 760-941-7130 Contact Email: hcosmos@filanc.com

CONTRACT INFORMATION	
Contract Title: Storm Drain at 5914 Agee Street	Start Date:
Contract Number (If no number, state location): K-18-1602-EMR-1	End Date:

**SUMMARY OF EQUAL BENEFITS ORDINANCE REQUIREMENTS**

The Equal Benefits Ordinance [EBO] requires the City to enter into contracts only with contractors who certify they will provide and maintain equal benefits as defined in SDMC §22.4302 for the duration of the contract. To comply:

- Contractor shall offer equal benefits to employees with spouses and employees with domestic partners.
  - Benefits include health, dental, vision insurance; pension/401(k) plans; bereavement, family, parental leave; discounts, child care; travel/relocation expenses; employee assistance programs; credit union membership; or any other benefit.
  - Any benefit not offered to an employee with a spouse, is not required to be offered to an employee with a domestic partner.
- Contractor shall post notice of firm's equal benefits policy in the workplace and notify employees at time of hire and during open enrollment periods.
- Contractor shall allow City access to records, when requested, to confirm compliance with EBO requirements.
- Contractor shall submit *EBO Certification of Compliance*, signed under penalty of perjury, prior to award of contract.

NOTE: This summary is provided for convenience. Full text of the EBO and Rules implementing the EBO are available at [www.sandiego.gov/administration](http://www.sandiego.gov/administration).

**CONTRACTOR EQUAL BENEFITS ORDINANCE CERTIFICATION**

Please indicate your firm's compliance status with the EBO. The City may request supporting documentation.

I affirm **compliance** with the EBO because my firm (*contractor must select one reason*):

- Provides equal benefits to spouses and domestic partners.
- Provides no benefits to spouses or domestic partners.
- Has no employees.
- Has collective bargaining agreement(s) in place prior to January 1, 2011, that has not been renewed or expired.

I request the City's approval to pay affected employees a cash equivalent in lieu of equal benefits and verify my firm made a reasonable effort but is not able to provide equal benefits upon contract award. I agree to notify employees of the availability of a cash equivalent for benefits available to spouses but not domestic partners and to continue to make every reasonable effort to extend all available benefits to domestic partners.

It is unlawful for any contractor to knowingly submit any false information to the City regarding equal benefits or cash equivalent associated with the execution, award, amendment, or administration of any contract. [San Diego Municipal Code §22.4307(a)]

Under penalty of perjury under laws of the State of California, I certify the above information is true and correct. I further certify that my firm understands the requirements of the Equal Benefits Ordinance and will provide and maintain equal benefits for the duration of the contract or pay a cash equivalent if authorized by the City.

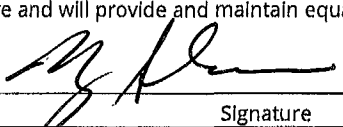
Harry S. Cosmos, President 

Name/Title of Signatory Signature Date

FOR OFFICIAL CITY USE ONLY	
Receipt Date: _____	EBO Analyst: _____ <input type="checkbox"/> Approved <input type="checkbox"/> Not Approved - Reason: _____

rev 02/15/2011

**EXHIBIT H**

**FORMS**

### LIST OF SUBCONTRACTORS

In accordance with the requirements of the "Subletting and Subcontracting Fair Practices Act", Section 4100, of the California Public Contract Code (PCC), the Bidder is to list below the name, address and license number of each Subcontractor who will perform work, labor, render services or specially fabricate and install a portion [type] of the work or improvement, in an amount of or in excess of 0.5% of the Contractor's total Bid. Failure to comply with this requirement may result in the Bid being rejected as non-responsive. The Contractor is to list only one Subcontractor for each portion of the Work. The Bidder's attention is directed to the Special Provisions - General; Paragraph 2-3 Subcontracts, which stipulates the percentage of the Work to be performed with the Bidder's own forces. The Bidder is to also list all SLBE, ELBE, DBE, DVBE, MBE, WBE, OBE, SDB, WoSB, HUBZone, and SDVOSB Subcontractors for which the Bidders are seeking recognition towards achieving any mandatory, voluntary, or both subcontracting participation percentages.

NAME, ADDRESS AND TELEPHONE NUMBER OF SUBCONTRACTOR	CONSTRUCTOR OR DESIGNER	SUBCONTRACTOR LICENSE NUMBER	TYPE OF WORK	DOLLAR VALUE OF SUBCONTRACT	MBE, WBE, DBE, DVBE, OBE, ELBE, SLBE, SDB, WoSB, HUBZone, OR SDVOSB <sup>ⓐ</sup>	WHERE CERTIFIED <sup>ⓑ</sup>	CHECK IF JOINT VENTURE PARTNERSHIP
Name: _____ Address: _____ City: _____ State: _____ Zip: _____ Phone: _____ Email: _____	n/a						
Name: _____ Address: _____ City: _____ State: _____ Zip: _____ Phone: _____ Email: _____							

① As appropriate, Bidder shall identify Subcontractor as one of the following and shall include a valid proof of certification (except for OBE, SLBE and ELBE):

Certified Minority Business Enterprise	MBE	Certified Woman Business Enterprise	WBE
Certified Disadvantaged Business Enterprise	DBE	Certified Disabled Veteran Business Enterprise	DVBE
Other Business Enterprise	OBE	Certified Emerging Local Business Enterprise	ELBE
Certified Small Local Business Enterprise	SLBE	Small Disadvantaged Business	SDB
Woman-Owned Small Business	WoSB	HUBZone Business	HUBZone
Service-Disabled Veteran Owned Small Business	SDVOSB		

② As appropriate, Bidder shall indicate if Subcontractor is certified by:

City of San Diego	CITY	State of California Department of Transportation	CALTRANS
California Public Utilities Commission	CPUC	State of California's Department of General Services	CADoGS
City of Los Angeles	LA	State of California	CA
U.S. Small Business Administration	SBA		

**The Bidder will not receive any subcontracting participation percentages if the Bidder fails to submit the required proof of certification.**

### NAMED EQUIPMENT/MATERIAL SUPPLIER LIST

The Bidder seeking the recognition of equipment, materials, or supplies obtained from Suppliers towards achieving any mandatory, voluntary, or both subcontracting participation percentages is to list the Supplier(s) on the Named Equipment/Material Supplier List. The Named Equipment/Material Supplier List, at a minimum, is to have the name, locations (City) and the **DOLLAR VALUE** of the Suppliers. The Bidder will be credited up to 60% of the amount to be paid to the Suppliers for such materials and supplies unless vendor manufactures or substantially alters materials and supplies in which case 100% will be credited. The Bidder is to indicate (Yes/No) whether listed firm is a supplier or manufacturer. In calculating the subcontractor participation percentages, vendors/suppliers will receive 60% credit of the listed **DOLLAR VALUE**, whereas manufacturers will receive 100% credit. If no indication provided, listed firm will be credited at 60% of the listed dollar value for purposes of calculating the Subcontractor Participation Percentage, Suppliers will receive 60% credit of the listed **DOLLAR VALUE**, whereas manufacturers will receive 100% credit. If no indication provided, listed firm will be credited at 60% of the listed **DOLLAR VALUE** for purposes of calculating the subcontractor participation percentages.

NAME, ADDRESS AND TELEPHONE NUMBER OF VENDOR/SUPPLIER	MATERIALS OR SUPPLIES	DOLLAR VALUE OF MATERIAL OR SUPPLIES (MUST BE FILLED OUT)	SUPPLIER (Yes/No)	MANUFACTURER (Yes/No)	MBE, WBE, DBE, DVBE, OBE, ELBE, SLBE, SDB, WoSB, HUBZone, OR SDVOSB <sup>①</sup>	WHERE CERTIFIED <sup>②</sup>
Name: _____ Address: _____ City: _____ State: _____ Zip: _____ Phone: _____ Email: _____	n/a					
Name: _____ Address: _____ City: _____ State: _____ Zip: _____ Phone: _____ Email: _____						

① As appropriate, Bidder shall identify Vendor/Supplier as one of the following and shall include a valid proof of certification (except for OBE, SLBE and ELBE):

Certified Minority Business Enterprise	MBE	Certified Woman Business Enterprise	WBE
Certified Disadvantaged Business Enterprise	DBE	Certified Disabled Veteran Business Enterprise	DVBE
Other Business Enterprise	OBE	Certified Emerging Local Business Enterprise	ELBE
Certified Small Local Business Enterprise	SLBE	Small Disadvantaged Business	SDB
Woman-Owned Small Business	WoSB	HUBZone Business	HUBZone
Service-Disabled Veteran Owned Small Business	SDVOSB		

② As appropriate, Bidder shall indicate if Vendor/Supplier is certified by:

City of San Diego	CITY	State of California Department of Transportation	CALTRANS
California Public Utilities Commission	CPUC	State of California's Department of General Services	CADoGS
City of Los Angeles	LA	State of California	CA
U.S. Small Business Administration	SBA		

**The Bidder will not receive any subcontracting participation percentages if the Bidder fails to submit the required proof of certification.**

**EXHIBIT I**

**SUPPLEMENTARY SPECIAL PROVISIONS (SSP)**

## **SUPPLEMENTARY SPECIAL PROVISIONS**

The following Supplementary Special Provisions (SSP) modifies the following documents:

- 1) The **2015 Edition** of the Standard Specifications for Public Works Construction (The "GREENBOOK").
- 2) The **2015 Edition** of the City of San Diego Standard Specifications for Public Works Construction (The "WHITEBOOK"), including the following:
  1. General Provisions (A) for all Contracts.

---

### **SECTION 1 – TERMS, DEFINITIONS, ABBREVIATIONS, UNITS OF MEASURE, AND SYMBOLS**

- 1-2 TERMS AND DEFINITIONS.** To the "WHITEBOOK", item 54, "Normal Working Hours", ADD the following:

The **Normal Working Hours** are 7:00 AM to 3:30 PM.

### **SECTION 2 - SCOPE AND CONTROL OF WORK**

- 2-3.2 Self Performance.** To the "GREENBOOK", DELETE in its entirety and SUBSTITUTE with the following:

1. You shall perform, with your own organization, Contract Work amounting to at least 50% of the base Bid **AND** 50% of any alternates.

- 2-16 CONTRACTOR REGISTRATION AND ELECTRONIC REPORTING SYSTEM.** To the "WHITEBOOK", item 1, DELETE in its entirety.

### **SECTION 3 – CHANGES IN WORK**

- 3-5.1 Claims.** To the "WHITEBOOK", DELETE in its entirety and SUBSTITUTE with the following:

**ADD:**

- 3-5.1 Claims.**

1. A Claim is a written demand by you that seeks an adjustment in the Contract Price, Contract Time, or other relief associated with a dispute arising under or relating to the Contract, including a breach of any provision thereof. A voucher, invoice, or other routine request for payment is not a Claim.

2. A Claim shall conform to these specifications and may be considered after the City has previously denied a request by you for a Change Order seeking the demanded relief.
3. You shall submit a Claim to the Engineer if a dispute occurs that arises from or relates to the Contract. The Claim shall seek all relief to which you assert you are entitled as a result of the event(s) giving rise to the dispute. Your failure to process a Claim in accordance with these specifications shall constitute a waiver of all relief associated with the dispute. Claims are subject to 6-11, "Right to Audit".
4. You shall continue to perform the Services and Work and shall maintain the Schedule during any dispute proceedings. The Engineer will continue to make payments for undisputed Services and Work.
5. The City's Claims process specified herein shall not relieve you of your statutory obligations to present claims prior to any action under the California Government Code.

**3-5.1.1 Initiation of Claim.**

1. You shall promptly, but no later than 30 Days after the event(s) giving rise to the Claim, deliver the Claim to the Engineer.
2. You shall not process a Claim unless the Engineer has previously denied a request by you for a Change Order that sought the relief to be pursued in the claim.

**3-5.1.1.1 Claim Certification Submittal.**

1. If your Claim seeks an increase in the Contract Price, the Contract Time, or both, submit with the Claim an affidavit certifying the following:
  - a) The Claim is made in good faith and covers all costs and delays to which you are entitled as a result of the event(s) giving rise to the Claim.
  - b) The amount claimed accurately reflects the adjustments in the Contract Price, the Contract Time, or both to which you believe you are entitled.
  - c) All supporting costs and pricing data are current, accurate, and complete to the best of your knowledge. The cost breakdown per item of Work shall be supplied.
  - d) You shall ensure that the affidavit is executed by an official who has the authority to legally bind you.

**3-5.1.2 Initial Determination.**

1. The Engineer will respond in writing to your Claim within 30 Days of receipt of the Claim.

**3-5.1.3 Settlement Meeting.**

1. If you disagree with the Initial Determination, you shall request a Settlement Meeting within 30 Days. Upon receipt of this request, the Engineer will schedule the Settlement Meeting within 15 Working Days.

**3-5.1.7 City's Final Determination.**

1. If a settle agreement is not reached, the City shall make a written Final Determination within 10 Working Days after the Settlement Meeting.
2. If you disagree with the City's Final Determination, notify the Engineer in writing of your objection within 15 Working Days after receipt of the written determination and file a "Request for Mediation" in accordance with 3-5.2, "Dispute Resolution Process".
3. Failure to give notice of objection within the 15 Working Days period shall waive your right to pursue the Claim.

**3-5.1.8 Mandatory Assistance.**

1. If a third party dispute, litigation, or both arises out of or relates in any way to the Services provided under the Contract, upon the City's request, you shall agree to assist in resolving the dispute or litigation. Your assistance includes, but is not limited to the following:
  - a) Providing professional consultations.
  - b) Attending mediations, arbitrations, depositions, trials, or any event related to the dispute resolution and litigation.

**3-5.1.8.1 Compensation for Mandatory Assistance.**

1. The City will reimburse you for reasonable fees and expenses incurred by you for any required assistance rendered in accordance with 3-5.1.8, "Mandatory Assistance" as Extra Work.
2. The Engineer will determine whether these fees and expenses were necessary due to your conduct or failure to act.
3. If the Engineer determines that the basis of the dispute or litigation in which these fees and expenses were incurred were the result of your conduct or your failure to act in part or in whole, you shall reimburse the City for any payments made for these fees and expenses.
4. Reimbursement may be through any legal means necessary, including the City's withholding of your payment.



### 3-5.2.3

**Selection of Mediator.** To the "WHITEBOOK", DELETE in its entirety and SUBSTITUTE with the following:

1. A single mediator, knowledgeable in construction aspects and acceptable to both parties, shall be used to mediate the dispute.
2. To initiate mediation, the initiating party shall serve a Request for Mediation at the American Arbitration Association (AAA) on the opposing party.
3. If AAA is used, the initiating party shall concurrently file with AAA a "Request for Mediation" along with the appropriate fees, a copy of requested mediators marked in preference order, and a preference for available dates.
4. If AAA is selected to coordinate the mediation (Administrator), within 10 Working Days from the receipt of the initiating party's Request for Mediation, the opposing party shall file the following:
  - a) A copy of the list of the preferred mediators listed in preference order after striking any mediators to which they have any objection.
  - b) A preference for available dates.
  - c) Appropriate fees.
5. If the parties cannot agree on a mediator, then each party shall select a mediator and those mediators shall select the neutral third party to mediate the matter.

### 3-5.3

**Forum of Litigation.** To the "WHITEBOOK", DELETE in its entirety and SUBSTITUTE with the following:

1. It is the express intention that all legal actions and proceedings related to the Contract or Agreement with the City or to any rights or any relationship between the parties arising therefrom shall be solely and exclusively initiated and maintained in courts of the State of California for the County of San Diego.

## SECTION 4 - CONTROL OF MATERIALS

### 4-1.3.2

**Inspection by the Agency.** To the "GREENBOOK", DELETE in its entirety and SUBSTITUTE with the following:

1. The City will provide inspection and testing laboratory services within the continental United States within a 200-mile radius of the geographical limits of the City.

**4-1.3.3 Inspection of Items Not Locally Produced.** To the "WHITEBOOK", DELETE in its entirety.

**ADD:**

**4-1.3.3 Inspection of Items Not Locally Produced.** To the "GREENBOOK", DELETE in its entirety and SUBSTITUTE with the following:

1. When you intend to purchase materials, fabricated products, or equipment from sources located more than 200 miles (321.9 km) outside the geographical limits of the City, City Lab staff or a qualified inspection agency approved by the Engineer, shall be engaged at your expense to inspect the materials, equipment, or process.
2. This approval shall be obtained before producing any material or equipment. City Lab staff or inspector shall evaluate the materials for conformance with the requirements of the Plans and Specifications. You shall forward reports required by the Engineer. No materials or equipment shall be shipped nor shall any processing, fabrication or treatment of such materials be done without proper inspection by City Lab staff or the approved agent. Approval by said agent shall not relieve you of responsibility for complying with the requirements of the Contract Documents.
3. The Engineer may elect City Lab staff to perform inspection of an out-of-town manufacturer. You shall incur additional inspection costs of the Engineer including lodging, meals, and incidental expenses based on Federal Per Diem Rates, along with travel and car rental expenses. If the manufacturing plant operates a double shift, a double shift shall be figured in the inspection costs.
  - a) At the option of the Engineer, full time inspection shall continue for the length of the manufacturing period. If the manufacturing period will exceed 3 consecutive weeks, you shall incur additional inspection expenses of the Engineer's supervisor for a trip of 2 Days to the site per month.
  - b) When the Engineer elects City Lab staff to perform out-of-town inspections, the wages of staff employed by the City shall not be part of the additional inspection expenses paid by you.
  - c) Federal Per Diem Rates can be determined at the location below:  
<https://www.gsa.gov/portal/content/104877>

**4-1.3.6 Preapproved Materials.** To the "WHITEBOOK", ADD the following:

3. You shall submit in writing a list of all products to be incorporated in the Work that are on the AML.

## **SECTION 5 – UTILITIES**

**5-2 PROTECTION.** To the "WHITEBOOK", item 2, ADD the following:

- g) Refer to Exhibit O for more information on the protection of AMI devices.

**5-6 COOPERATION.** To the "GREENBOOK", ADD the following:

1. Notify SDG&E at least 10 Working Days prior to excavating within 10 feet of SDG&E Underground High Voltage Transmission Power Lines (69 KV and higher).

## **SECTION 6 - PROSECUTION, PROGRESS AND ACCEPTANCE OF WORK**

**ADD:**

**6-3.2.1.1 Environmental Document.**

1. The City of San Diego Public Works Department has prepared a **Notice of Exemption** for **Agee Street Emergency Project (Storm Drain at 5914 Agee Street University City South Storm Drain Replacement)** as referenced in the Contract Exhibit. You shall comply with all requirements of the **Notice of Exemption** as set forth in Exhibit A.

**6-7.1 General.** To the "WHITEBOOK", item 3, ADD the following:

- d) 30 Days for full depth asphalt final mill and resurfacing work required per SDG-107.
- e) Where shutdowns of 16 inch and larger pipes are required, there is a shutdown moratorium from May until October. Plan and schedule Work accordingly. No additional payment or Working Days will be granted for delays due to the moratorium.

**6-8.3 Warranty.** To the "WHITEBOOK", item 1, DELETE in its entirety and SUBSTITUTE with the following:

1. Warranty and repair all defective materials and workmanship for a period of 1 year. This call back warranty period shall start on the date that the Work was accepted by the City. Additionally, you shall warranty the Work against all latent and patent defects for a period of 10 years.

## **SECTION 7 - RESPONSIBILITIES OF THE CONTRACTOR**

**7-3 INSURANCE.** To the "GREENBOOK", DELETE in its entirety and SUBSTITUTE with the following:

**7-3 INSURANCE.**

1. The insurance provisions herein shall not be construed to limit your indemnity obligations contained in the Contract.

**7-3.1 Policies and Procedures.**

1. You shall procure the insurance described below, at its sole cost and expense, to provide coverage against claims for loss including injuries to persons or damage to property, which may arise out of or in connection with the performance of the Work by you, your agents, representatives, officers, employees or Subcontractors.
2. Insurance coverage for property damage resulting from your operations is on a replacement cost valuation. The market value will not be accepted.
3. You shall maintain this insurance for the duration of this Contract and at all times thereafter when you are correcting, removing, or replacing Work in accordance with this Contract. Your liabilities under the Contract, e.g., your indemnity obligations, is not deemed limited to the insurance coverage required by this Contract.
4. The payment for insurance shall be included in the Contract Price as bid by you. Except as specifically agreed to by the City in writing, you are not entitled to any additional payment. Do not begin any Work under this Contract until you have provided and the City has approved all required insurance.
5. Policies of insurance shall provide that the City is entitled to 30 Days (10 Days for cancellation due to non-payment of premium) prior written notice of cancellation or non-renewal of the policy. Maintenance of specified insurance coverage is a material element of the Contract. Your failure to maintain or renew coverage or to provide evidence of renewal during the term of the Contract may be treated by the City as a material breach of the Contract.

**7-3.2 Types of Insurance.**

**7-3.2.1 Commercial General Liability Insurance.**

1. Commercial General Liability Insurance shall be written on the current version of the ISO Occurrence form CG 00 01 07 98 or an equivalent form providing coverage at least as broad.

2. The policy shall cover liability arising from premises and operations, XCU (explosions, underground, and collapse), independent contractors, products/completed operations, personal injury and advertising injury, bodily injury, property damage, and liability assumed under an insured's contract (including the tort liability of another assumed in a business contract).
3. There shall be no endorsement or modification limiting the scope of coverage for either "insured vs. insured" claims or contractual liability. You shall maintain the same or equivalent insurance for at least 10 years following completion of the Work.
4. All costs of defense shall be outside the policy limits. Policy coverage shall be in liability limits of not less than the following:

<u>General Annual Aggregate Limit</u>	<u>Limits of Liability</u>
Other than Products/Completed Operations	\$2,000,000
Products/Completed Operations Aggregate Limit	\$2,000,000
Personal Injury Limit	\$1,000,000
Each Occurrence	\$1,000,000

**7-3.2.2 Commercial Automobile Liability Insurance.**

1. You shall provide a policy or policies of Commercial Automobile Liability Insurance written on the current version of the ISO form CA 00 01 12 90 or later version or equivalent form providing coverage at least as broad in the amount of \$1,000,000 combined single limit per accident, covering bodily injury and property damage for owned, non-owned, and hired automobiles ("Any Auto").
2. All costs of defense shall be outside the limits of the policy.

**7-3.3 Rating Requirements.** Except for the State Compensation Insurance Fund, all insurance required by this Contract as described herein shall be carried only by responsible insurance companies with a rating of, or equivalent to, at least "A-, VI" by A.M. Best Company, that are authorized by the California Insurance Commissioner to do business in the State, and that have been approved by the City.

**7-3.3.1 Non-Admitted Carriers.** The City will accept insurance provided by non-admitted, "surplus lines" carriers only if the carrier is authorized to do business in the State and is included on the List of Approved Surplus Lines Insurers (LASLI list).

All policies of insurance carried by non-admitted carriers shall be subject to all of the requirements for policies of insurance provided by admitted carriers described herein.

**7-3.4 Evidence of Insurance.** Furnish to the City documents e.g., certificates of insurance and endorsements evidencing the insurance required herein, and furnish renewal documentation prior to expiration of this insurance. Each required document shall be signed by the insurer or a person authorized by the insurer to bind coverage on its behalf. We reserve the right to require complete, certified copies of all insurance policies required herein.

**7-3.5 Policy Endorsements.**

**7-3.5.1 Commercial General Liability Insurance.**

**7-3.5.1.1 Additional Insured.**

- a) You shall provide at your expense policy endorsement written on the current version of the ISO Occurrence form CG 20 10 11 85 or an equivalent form providing coverage at least as broad.
- b) To the fullest extent allowed by law e.g., California Insurance Code §11580.04, the policy shall be endorsed to include the City and its respective elected officials, officers, employees, agents, and representatives as additional insured.
- c) The additional insured coverage for projects for which the Engineer's Estimate is \$1,000,000 or more shall include liability arising out of:
  - a) Ongoing operations performed by you or on your behalf,
  - b) your products,
  - c) your Work, e.g., your completed operations performed by you or on your behalf, or
  - d) premises owned, leased, controlled, or used by you.
- d) The additional insured coverage for projects for which the Engineer's Estimate is less than \$1,000,000 shall include liability arising out of:
  - a) Ongoing operations performed by you or on your behalf,
  - b) your products, or
  - c) premises owned, leased, controlled, or used by you.

**7-3.5.1.2 Primary and Non-Contributory Coverage.** The policy shall be endorsed to provide that the coverage with respect to operations, including the completed operations, if appropriate, of the Named Insured is primary to any insurance or self-insurance of the City and its elected officials, officers, employees, agents and representatives. Further, it shall provide that any insurance maintained by the City and its elected officials, officers, employees, agents and representatives shall be in excess of your insurance and shall not contribute to it.

**7-3.5.1.3 Project General Aggregate Limit.** The policy or policies shall be endorsed to provide a Designated Construction Project General Aggregate Limit that will apply only to the Work. Only claims payments which arise from the Work shall reduce the Designated Construction Project General Aggregate Limit. The Designated

Construction Project General Aggregate Limit shall be in addition to the aggregate limit provided for the products-completed operations hazard.

**7-3.5.2 Commercial Automobile Liability Insurance.**

**7-3.5.2.1 Additional Insured.** Unless the policy or policies of Commercial Auto Liability Insurance are written on an ISO form CA 00 01 12 90 or a later version of this form or equivalent form providing coverage at least as broad, the policy shall be endorsed to include the City and its respective elected officials, officers, employees, agents, and representatives as additional insured, with respect to liability arising out of automobiles owned, leased, hired or borrowed by you or on your behalf. This endorsement is limited to the obligations permitted by California Insurance Code §11580.04.

**7-3.6 Deductibles and Self-Insured Retentions.** You shall pay for all deductibles and self-insured retentions. You shall disclose deductibles and self-insured retentions to the City at the time the evidence of insurance is provided.

**7-3.7 Reservation of Rights.** The City reserves the right, from time to time, to review your insurance coverage, limits, deductibles and self-insured retentions to determine if they are acceptable to the City. The City will reimburse you, without overhead, profit, or any other markup, for the cost of additional premium for any coverage requested by the Engineer but not required by this Contract.

**7-3.8 Notice of Changes to Insurance.** You shall notify the City 30 Days prior to any material change to the policies of insurance provided under this Contract.

**7-3.9 Excess Insurance.** Policies providing excess coverage shall follow the form of the primary policy or policies e.g., all endorsements.

**7-4 NOT USED.** To the "GREENBOOK", DELETE in its entirety and SUBSTITUTE with the following:

**7-4 WORKERS' COMPENSATION INSURANCE AND EMPLOYERS LIABILITY INSURANCE.**

1. In accordance with the provisions of §3700 of the California Labor Code, you shall provide at your expense Workers' Compensation Insurance and Employers Liability Insurance to protect you against all claims under applicable state workers compensation laws. The City, its elected officials, and employees will not be responsible for any claims in law or equity occasioned by your failure to comply with the requirements of this section.
2. Limits for this insurance shall be not less than the following:

<u>Workers' Compensation</u>	<u>Statutory Employers Liability</u>
Bodily Injury by Accident	\$1,000,000 each accident
Bodily Injury by Disease	\$1,000,000 each employee
Bodily Injury by Disease	\$1,000,000 policy limit

3. By signing and returning the Contract you certify that you are aware of the provisions of §3700 of the Labor Code which requires every employer to be insured against liability for worker's compensation or to undertake self-insurance in accordance with the provisions of that code and you shall comply with such provisions before commencing the Work as required by §1861 of the California Labor Code.

**7-4.1. Waiver of Subrogation.** The policy or policies shall be endorsed to provide that the insurer will waive all rights of subrogation against the City and its respective elected officials, officers, employees, agents, and representatives for losses paid under the terms of the policy or policies and which arise from Work performed by the Named Insured for the City.

**7-8.6 Water Pollution Control.** To the "WHITEBOOK", ADD the following:

6. Based on a preliminary assessment by the City, this Contract is subject to Minor WPCP.

**7-20 ELECTRONIC COMMUNICATION.** To the "WHITEBOOK", ADD the following:

2. Virtual Project Manager shall be used on this Contract.

**7-21.1 General.** To the "WHITEBOOK", item 3, DELETE in its entirety and SUBSTITUTE with the following:

3. During the construction phase of projects, the minimum waste management reduction goal is 90% of the inert material (a material not subject to decomposition such as concrete, asphalt, brick, rock, block, dirt, metal, glass, and etc.) and 65% of the remaining project waste. You shall provide appropriate documentation, including a Waste Management Form attached as an appendix, and evidence of recycling and reuse of materials to meet the waste reduction goals specified.

**7-21.6 Special Project Conditions.** To the "WHITEBOOK", item 1, DELETE in its entirety and SUBSTITUTE with the following:

1. When removal of sediments and debris from channels and storm drains are required, you shall make a preliminary estimate of the materials that can be diverted to beneficial use. Receipts from disposal, re-use, and recycling options shall indicate that 65% of materials are diverted.



**SECTION 9 - MEASUREMENT AND PAYMENT**

**ADD:**

**9-3.7 Compensation Adjustments for Price Index Fluctuations.** To the "WHITEBOOK" ADD the following:

5. This Contract is not subject to the provisions of The "WHITEBOOK" for Compensation Adjustments for Price Index Fluctuations for paving asphalt.

**SECTION 217 - BEDDING AND BACKFILL MATERIALS**

**217-2.2 Stones, Boulders, and Broken Concrete.** To the "GREENBOOK", Table 217-2.2, DELETE in its entirety and SUBSTITUTE with the following:

**TABLE 217-2.2**

<b>Zone</b>	<b>Zone Limits</b>	<b>Maximum Size (greatest dimension)</b>	<b>Backfill Requirements in Addition to 217-2.1</b>
Street or Surface Zone	From ground surface to 12" (300 mm) below pavement subgrade or ground surface	2.5" (63 mm)	As required by the Plans or Special Provisions.
Street or Surface Zone Backfill of Tunnels beneath Concrete Flatwork		Sand	Sand equivalent of not less than 30.
Trench Zone	From 12" (300 mm) below pavement subgrade or ground surface to 12" (300 mm) above top of pipe or box	6" (150 mm)	
Deep Trench Zone (Trenches 3' (0.9 m) wide or wider)	From 60" (1.5 m) below finished surface to 12" (300 mm) above top of pipe or box	Rocks up to 12" (300 mm) excavated from trench may be placed as backfill	
Pipe Zone	From 12" (300 mm) above top of pipe or box to 6" (150 mm) below bottom of pipe or box exterior	2.5" (63 mm)	Sand equivalent of not less than 30 or a coefficient of permeability greater than 1-½ inches/hour (35 mm per hour).
Overexcavation	Backfill more than 6" (150 mm) below bottom of pipe or box exterior	6" (150 mm)	Sand equivalent of not less than 30 or a coefficient of permeability greater than 1-½ inches/hour (35 mm per hour). Trench backfill slurry (100-E-100) per 201-1 may also be used.

**EQUAL OPPORTUNITY CONTRACTING PROGRAM (EOCP) SECTION A – GENERAL  
REQUIREMENTS**

**4.1 Nondiscrimination in Contracting Ordinance.** To the “WHITEBOOK”, subsection 4.1.1, paragraph (2), sentence (1), DELETE in its entirety and SUBSTITUTE with the following:

You shall not discriminate on the basis of race, gender, gender expression, gender identity, religion, national origin, ethnicity, sexual orientation, age, or disability in the solicitation, selection, hiring, or treatment of subcontractors, vendors, or suppliers.

**END OF SUPPLEMENTARY SPECIAL PROVISIONS (SSP)**

**EXHIBIT J**

**PROPOSAL**

**EXHIBIT J**

**PROPOSAL**

To the City of San Diego:

In accordance with the RFQ, the Contractors proposal, the specifications and requirements on file with the City Clerk and the Contract documents, and subject to all provisions of the Charter and Ordinances of the City of San Diego and applicable laws and regulations of the United States and the State of California, the undersigned hereby proposes to furnish to the City of San Diego, complete at the prices stated herein, the items or services hereinafter mentioned. The undersigned further warrants that this bid is not made in the interest of, or on behalf of, any undisclosed person, partnership, company, association, organization, or corporation; that the bid is genuine and not collusive or sham; that the bidder has not directly or indirectly induced or solicited any other bidder to put in a false or sham bid, and has not directly or indirectly colluded, conspired, connived, or agreed with any bidder or anyone else to put in a sham bid, or that anyone shall refrain from bidding; that the bidder has not in any manner, directly or indirectly, sought by agreement, communication, or conference with anyone to fix the bid price of the bidder or any other bidder, or to fix any overhead, profit, or cost element of the bid price, or of that of any other bidder, or to secure any advantage against the public body awarding the contract of anyone interested in the proposed contract; that all statements contained in the bid are true; and, further, that the bidder has not, directly or indirectly, submitted his or her bid price or any breakdown thereof, or the contents thereof, or divulged information or data relative thereto, or paid, and will not pay, any fee to any corporation, partnership, company, association, organization, bid depository, or to any member or agent thereof to effectuate a collusive or sham bid.

The undersigned bidder(s) further warrants that bidder(s) has thoroughly examined and understands the entire Contract Documents (plans and specifications) and the Bidding Documents therefore, and that by submitting said Bidding Documents as its bid proposal, bidder(s) acknowledges and is bound by the entire Contract Documents, including any addenda issued thereto, as such Contract Documents incorporated by reference in the Bidding Documents.

**IF A SOLE OWNER OR SOLE CONTRACTOR SIGN HERE:**

n/a

(1) Name under which business is conducted \_\_\_\_\_

(2) Signature (Given and surname) of proprietor \_\_\_\_\_

(3) Place of Business (Street & Number) \_\_\_\_\_

(4) City and State \_\_\_\_\_ Zip Code \_\_\_\_\_

(5) Telephone No. \_\_\_\_\_ Facsimile No. \_\_\_\_\_

**IF A PARTNERSHIP, SIGN HERE:** n/a

- (1) Name under which business is conducted \_\_\_\_\_
- (2) Name of each member of partnership, indicate character of each partner, general or special (limited):  
\_\_\_\_\_  
\_\_\_\_\_
- (3) Signature (Note: Signature must be made by a general partner)  
\_\_\_\_\_  
Full Name and Character of partner  
\_\_\_\_\_  
\_\_\_\_\_
- (4) Place of Business (Street & Number) \_\_\_\_\_
- (5) City and State \_\_\_\_\_ Zip Code \_\_\_\_\_
- (6) Telephone No. \_\_\_\_\_ Facsimile No. \_\_\_\_\_

**IF A CORPORATION, SIGN HERE:**

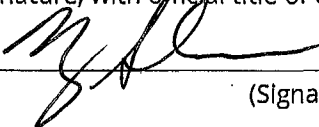
- (1) Name under which business is conducted J.R. Filanc Construction Company, Inc.
- (2) Signature, with official title of officer authorized to sign for the corporation:  
  
\_\_\_\_\_  
(Signature)  
Harry S. Cosmos  
\_\_\_\_\_  
(Printed Name)  
President  
\_\_\_\_\_  
(Title of Officer)  

(Impress Corporate Seal Here)
- (3) Incorporated under the laws of the State of California
- (4) Place of Business (Street & Number) 740 N. Andreasen Drive
- (5) City and State Escondido, CA Zip Code 92029
- (6) Telephone No. 760-941-7130 Facsimile No. 760-941-3969

**THE FOLLOWING SECTIONS MUST BE FILLED IN BY ALL PROPOSERS:**

In accordance with the "GENERAL INSTRUCTIONS", the bidder holds a California State Contractor's license for the following classification(s) to perform the work described in these specifications:

LICENSE CLASSIFICATION A

LICENSE NO. 134877 EXPIRES 9/30/17

DEPARTMENT OF INDUSTRIAL RELATIONS (DIR) REGISTRATION NUMBER: \_\_\_\_\_

100001631

This license classification must also be shown on the front of the bid envelope. Failure to show license classification on the bid envelope may cause return of the bid unopened.

TAX IDENTIFICATION NUMBER (TIN): [REDACTED]

E-Mail Address: hcosmos@filanc.com

**THIS PROPOSAL MUST BE NOTARIZED BELOW:**

I certify, under penalty of perjury, that the representations made herein regarding my State Contractor's license number, classification and expiration date are true and correct.

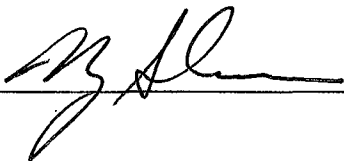
Signature  Title Harry S. Cosmos, President

SUBSCRIBED AND SWORN TO BEFORE ME, THIS \_\_\_\_\_ DAY OF \_\_\_\_\_

Notary Public In and for the County of \_\_\_\_\_, State of \_\_\_\_\_

(NOTARIAL SEAL)

See attached

A notary public or other officer completing this certificate verifies only the identity of the individual who signed the document to which this certificate is attached, and not the truthfulness, accuracy, or validity of that document.

State of California  
County of San Diego

Subscribed and sworn to (or affirmed) before me on this \_\_\_\_\_  
day of August 17, 2017, by Harry S. Cosmos

proved to me on the basis of satisfactory evidence to be the  
person(s) who appeared before me.

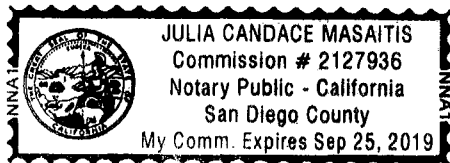

Signature Julia Candace Masaitis

**EXHIBIT K**

**CONTRACTOR'S COMPENSATION RATE SCHEDULE**



J.R. FILANC CONSTRUCTION COMPANY, INC  
 LABOR RATES – AGEE STREET

CONSTRUCTION		RATE/ HR
Laborer	Journeyman	\$ 63.68
Laborer	Foreman	\$ 65.43
Cement Mason	Journeyman	\$ 63.07
Operating Engineer	Group 8	\$ 88.91
Operating Engineer	Foreman	\$ 90.91
Carpenter	Journeyman	\$ 71.23
Carpenter	Foreman	\$ 75.13
Teamster	Journeyman	\$ 67.76
Pipefitter	Journeyman	\$ 87.40
Pipefitter	Foreman	\$ 95.54
Project Manager		\$ 125.84
Superintendent		\$ 97.76
Project Engineer		\$ 54.60
Pre-Construction Manager		\$ 114.40
Estimator		\$ 114.40
Safety Engineer		\$ 75.92
Project Administrator		\$ 37.44

**EXHIBIT L**

**NOTICE OF EXEMPTION**

**NOTICE OF EXEMPTION**

(Check one or both)

TO:  Recorder/County Clerk  
P.O. Box 1750, MS A-33  
1600 Pacific Hwy, Room 260  
San Diego, CA 92101-2400

FROM: City of San Diego  
Public Works Department  
525 B Street, Suite 750, MS908A  
San Diego, CA 92101

Office of Planning and Research  
1400 Tenth Street, Room 121  
Sacramento, CA 95814

**Project Name:** Agee Street Emergency Project

**Project/WBS No:** TBD

**Project Location-Specific:** 5914 Agee Street

**Project Location-City/County:** San Diego/San Diego

**Description of nature and purpose of the Project:** A 24 inch diameter corrugated metal pipe (CMP) storm drain has failed and formed a sink hole in the public right-of-way located in front of the single-family residence located at 5914 Agee Street. The collapsed asphalt and soil has fallen on top of the water service to this residence. Water service for approximately 15 homes will need to be shut off if the water service fails. Work will include, but is not limited to, temporarily filling the void and plating the hole, a new clean out north of the sink hole, replace approximately 30 linear feet of 24 inch CMP with 24 inch reinforced concrete pipe (RCP) storm drain. All replacement will occur within the existing alignment (previously disturbed soils). The sink hole will be filled to pre-emergency grade and compaction. The contractor will be tasked with diverting any storm water flow throughout the duration of repair work. All staging activities would occur within the developed, public right-of-way. The project will not impact any environmentally sensitive lands or resources

**Name of Public Agency Approving Project:** City of San Diego

**Name of Person or Agency Carrying Out Project:** City of San Diego, Public Works Department  
Natalie de Freitas  
525 B Street, Suite 750 (MS 908A), San Diego, CA 92101  
(619) 533-4603

**Exempt Status: (CHECK ONE)**

- Ministerial (Sec. 21080(b)(1); 15268);
- Declared Emergency (Sec. 21080(b)(3); 15269(a));
- Emergency Project (Sec. 21080(b)(4); 15269(b)(c))

**Reasons why project is exempt:** The emergency repairs are required in order to protect public health, safety and property. This determination is supported by the expert opinion of the City Engineer. The City of San Diego conducted an environmental review which determined that the project meets the statutory exemption criteria set forth in CEQA State Guidelines, Section (SEC. 21080(b)(4); 15269 (b)(c)).

**Lead Agency Contact Person:** Natalie de Freitas, Senior Planner      **Telephone:** (619)533-4603

**If filed by applicant:**

1. Attach certified document of exemption finding.
2. Has a notice of exemption been filed by the public agency approving the project? ( ) Yes ( ) No

It is hereby certified that the City of San Diego has determined the above activity to be exempt from CEQA

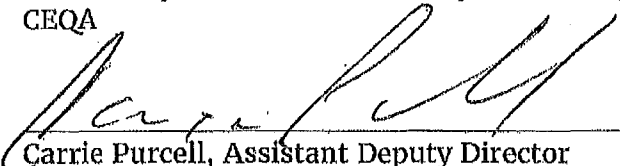
  
\_\_\_\_\_  
Carrie Purcell, Assistant Deputy Director

6/9/17  
Date

Check One:

- Signed By Lead Agency
- Signed by Applicant

Date Received for Filing with County Clerk or OPR:

**EXHIBIT M**

**LOCATION MAP**

THIS MAP/DATA IS PROVIDED WITHOUT WARRANTY OF ANY KIND, EITHER EXPRESS OR IMPLIED, INCLUDING, BUT NOT LIMITED TO, THE IMPLIED WARRANTIES OR MERCHANTABILITY AND FITNESS FOR A PARTICULAR PURPOSE. Note: This product may contain information from the SANDAG Regional Information System which cannot be reproduced without the written permission of SANDAG.

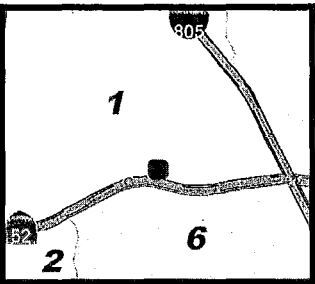

The City of  
**SAN DIEGO** Public Works

**5914 AGEE ST SD EMERGENCY**

SENIOR ENGINEER  
JONG CHOI  
(619) 533-5493

PROJECT MANAGER  
JESS ARCILLAS  
(619) 533-4625

FOR QUESTIONS ABOUT THIS PROJECT  
Call: 619-533-4207  
Email: [engineering@sandiego.gov](mailto:engineering@sandiego.gov)



**Legend**

 Agee\_St\_SD

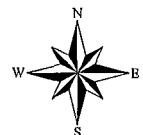

COMMUNITY NAME: UNIVERSITY

COUNCIL DISTRICT: 1

SAP ID: B0000 (S) \  
B0000 (W)

Storm Drain at 5914 Agee Street (University City South Storm Drain Replacement)



**EXHIBIT N**

**STORM WATER APPLICABILITY CHECKLIST (DS-560)**



City of San Diego  
Development Services  
1222 First Ave., MS-302  
San Diego, CA 92101  
(619) 446-5000

# Storm Water Requirements Applicability Checklist

FORM  
**DS-560**  
OCTOBER 2016

Project Address: **5914 Agee St**

Project Number (for City Use Only):

## SECTION 1. Construction Storm Water BMP Requirements:

All construction sites are required to implement construction BMPs in accordance with the performance standards in the Storm Water Standards Manual. Some sites are additionally required to obtain coverage under the State Construction General Permit (CGP)<sup>1</sup>, which is administered by the State Water Resources Control Board.

**For all projects complete PART A: If project is required to submit a SWPPP or WPCP, continue to PART B.**

### PART A: Determine Construction Phase Storm Water Requirements.

1. Is the project subject to California's statewide General NPDES permit for Storm Water Discharges Associated with Construction Activities, also known as the State Construction General Permit (CGP)? (Typically projects with land disturbance greater than or equal to 1 acre.)

Yes; SWPPP required, skip questions 2-4     No; next question

2. Does the project propose construction or demolition activity, including but not limited to, clearing, grading, grubbing, excavation, or any other activity resulting in ground disturbance and contact with storm water runoff?

Yes; WPCP required, skip 3-4     No; next question

3. Does the project propose routine maintenance to maintain original line and grade, hydraulic capacity, or original purpose of the facility? (Projects such as pipeline/utility replacement)

Yes; WPCP required, skip 4     No; next question

4. Does the project only include the following Permit types listed below?

- Electrical Permit, Fire Alarm Permit, Fire Sprinkler Permit, Plumbing Permit, Sign Permit, Mechanical Permit, Spa Permit.
- Individual Right of Way Permits that exclusively include only ONE of the following activities: water service, sewer lateral, or utility service.
- Right of Way Permits with a project footprint less than 150 linear feet that exclusively include only ONE of the following activities: curb ramp, sidewalk and driveway apron replacement, pot holing, curb and gutter replacement, and retaining wall encroachments.

Yes; no document required

Check one of the boxes below, and continue to PART B:

If you checked "Yes" for question 1, **a SWPPP is REQUIRED. Continue to PART B**

If you checked "No" for question 1, and checked "Yes" for question 2 or 3, **a WPCP is REQUIRED.** If the project proposes less than 5,000 square feet of ground disturbance AND has less than a 5-foot elevation change over the entire project area, a Minor WPCP may be required instead. **Continue to PART B.**

If you checked "No" for all questions 1-3, and checked "Yes" for question 4 **PART B does not apply and no document is required. Continue to Section 2.**

Minor WPCP

1. More information on the City's construction BMP requirements as well as CGP requirements can be found at: [www.sandiego.gov/stormwater/regulations/index.shtml](http://www.sandiego.gov/stormwater/regulations/index.shtml)

Printed on recycled paper. Visit our web site at [www.sandiego.gov/development-services](http://www.sandiego.gov/development-services).

Upon request, this information is available in alternative formats for persons with disabilities.

DS-560 (10-16)



**PART B: Determine Construction Site Priority**

This prioritization must be completed within this form, noted on the plans, and included in the SWPPP or WPCP. The city reserves the right to adjust the priority of projects both before and after construction. Construction projects are assigned an inspection frequency based on if the project has a "high threat to water quality." The City has aligned the local definition of "high threat to water quality" to the risk determination approach of the State Construction General Permit (CGP). The CGP determines risk level based on project specific sediment risk and receiving water risk. Additional inspection is required for projects within the Areas of Special Biological Significance (ASBS) watershed. **NOTE:** The construction priority does **NOT** change construction BMP requirements that apply to projects; rather, it determines the frequency of inspections that will be conducted by city staff.

**Complete PART B and continued to Section 2**

- 1.  **ASBS**
  - a. Projects located in the ASBS watershed.
- 2.  **High Priority**
  - a. Projects 1 acre or more determined to be Risk Level 2 or Risk Level 3 per the Construction General Permit and not located in the ASBS watershed.
  - b. Projects 1 acre or more determined to be LUP Type 2 or LUP Type 3 per the Construction General Permit and not located in the ASBS watershed.
- 3.  **Medium Priority**
  - a. Projects 1 acre or more but not subject to an ASBS or high priority designation.
  - b. Projects determined to be Risk Level 1 or LUP Type 1 per the Construction General Permit and not located in the ASBS watershed.
- 4.  **Low Priority**
  - a. Projects requiring a Water Pollution Control Plan but not subject to ASBS, high, or medium priority designation.

**SECTION 2. Permanent Storm Water BMP Requirements.**

Additional information for determining the requirements is found in the [Storm Water Standards Manual](#).

**PART C: Determine if Not Subject to Permanent Storm Water Requirements.**

Projects that are considered maintenance, or otherwise not categorized as "new development projects" or "redevelopment projects" according to the [Storm Water Standards Manual](#) are not subject to Permanent Storm Water BMPs.

**If "yes" is checked for any number in Part C, proceed to Part F and check "Not Subject to Permanent Storm Water BMP Requirements".**

**If "no" is checked for all of the numbers in Part C continue to Part D.**

- 1. Does the project only include interior remodels and/or is the project entirely within an existing enclosed structure and does not have the potential to contact storm water?  Yes  No
- 2. Does the project only include the construction of overhead or underground utilities without creating new impervious surfaces?  Yes  No
- 3. Does the project fall under routine maintenance? Examples include, but are not limited to: roof or exterior structure surface replacement, resurfacing or reconfiguring surface parking lots or existing roadways without expanding the impervious footprint, and routine replacement of damaged pavement (grinding, overlay, and pothole repair).  Yes  No

**PART D: PDP Exempt Requirements.**

PDP Exempt projects are required to implement site design and source control BMPs.

If "yes" was checked for any questions in Part D, continue to Part F and check the box labeled "PDP Exempt."

If "no" was checked for all questions in Part D, continue to Part E.

1. Does the project ONLY include new or retrofit sidewalks, bicycle lanes, or trails that:

- Are designed and constructed to direct storm water runoff to adjacent vegetated areas, or other non-erodible permeable areas? Or;
- Are designed and constructed to be hydraulically disconnected from paved streets and roads? Or;
- Are designed and constructed with permeable pavements or surfaces in accordance with the Green Streets guidance in the City's Storm Water Standards manual?

Yes; PDP exempt requirements apply       No; next question

2. Does the project ONLY include retrofitting or redeveloping existing paved alleys, streets or roads designed and constructed in accordance with the Green Streets guidance in the City's Storm Water Standards Manual?

Yes; PDP exempt requirements apply       No; project not exempt.

**PART E: Determine if Project is a Priority Development Project (PDP).**

Projects that match one of the definitions below are subject to additional requirements including preparation of a Storm Water Quality Management Plan (SWQMP).

If "yes" is checked for any number in PART E, continue to PART F and check the box labeled "Priority Development Project".

If "no" is checked for every number in PART E, continue to PART F and check the box labeled "Standard Development Project".

1. **New Development that creates 10,000 square feet or more of impervious surfaces collectively over the project site.** This includes commercial, industrial, residential, mixed-use, and public development projects on public or private land.

Yes     No

2. **Redevelopment project that creates and/or replaces 5,000 square feet or more of impervious surfaces on an existing site of 10,000 square feet or more of impervious surfaces.** This includes commercial, industrial, residential, mixed-use, and public development projects on public or private land.

Yes     No

3. **New development or redevelopment of a restaurant.** Facilities that sell prepared foods and drinks for consumption, including stationary lunch counters and refreshment stands selling prepared foods and drinks for immediate consumption (SIC 5812), and where the land development creates and/or replace 5,000 square feet or more of impervious surface.

Yes     No

4. **New development or redevelopment on a hillside.** The project creates and/or replaces 5,000 square feet or more of impervious surface (collectively over the project site) and where the development will grade on any natural slope that is twenty-five percent or greater.

Yes     No

5. **New development or redevelopment of a parking lot that creates and/or replaces 5,000 square feet or more of impervious surface (collectively over the project site).**

Yes     No

6. **New development or redevelopment of streets, roads, highways, freeways, and driveways.** The project creates and/or replaces 5,000 square feet or more of impervious surface (collectively over the project site).

Yes     No

- 7. **New development or redevelopment discharging directly to an Environmentally Sensitive Area.** The project creates and/or replaces 2,500 square feet of impervious surface (collectively over project site), and discharges directly to an Environmentally Sensitive Area (ESA). "Discharging directly to" includes flow that is conveyed overland a distance of 200 feet or less from the project to the ESA, or conveyed in a pipe or open channel any distance as an isolated flow from the project to the ESA (i.e. not commingled with flows from adjacent lands).  Yes  No

---

- 8. **New development or redevelopment projects of a retail gasoline outlet (RGO) that create and/or replaces 5,000 square feet of impervious surface.** The development project meets the following criteria: (a) 5,000 square feet or more or (b) has a projected Average Daily Traffic (ADT) of 100 or more vehicles per day.  Yes  No

---

- 9. **New development or redevelopment projects of an automotive repair shops that creates and/or replaces 5,000 square feet or more of impervious surfaces.** Development projects categorized in any one of Standard Industrial Classification (SIC) codes 5013, 5014, 5541, 7532-7534, or 7536-7539.  Yes  No

---

- 10. **Other Pollutant Generating Project.** The project is not covered in the categories above, results in the disturbance of one or more acres of land and is expected to generate pollutants post construction, such as fertilizers and pesticides. This does not include projects creating less than 5,000 sf of impervious surface and where added landscaping does not require regular use of pesticides and fertilizers, such as slope stabilization using native plants. Calculation of the square footage of impervious surface need not include linear pathways that are for infrequent vehicle use, such as emergency maintenance access or bicycle pedestrian use, if they are built with pervious surfaces of if they sheet flow to surrounding pervious surfaces.  Yes  No

**PART F: Select the appropriate category based on the outcomes of PART C through PART E.**

- 1. The project is **NOT SUBJECT TO PERMANENT STORM WATER REQUIREMENTS.**

---

- 2. The project is a **STANDARD DEVELOPMENT PROJECT.** Site design and source control BMP requirements apply. See the Storm Water Standards Manual for guidance.

---

- 3. The project is **PDP EXEMPT.** Site design and source control BMP requirements apply. See the Storm Water Standards Manual for guidance.

---

- 4. The project is a **PRIORITY DEVELOPMENT PROJECT.** Site design, source control, and structural pollutant control BMP requirements apply. See the Storm Water Standards Manual for guidance on determining if project requires a hydromodification plan management

Jong Choi

Senior Engineer - Civil

Name of Owner or Agent (Please Print)

Title

Signature



Date

7/19/17

**EXHIBIT O**

**ADVANCED METERING INFRASTRUCTURE (AMI) DEVICE PROTECTION**

## Protecting AMI Devices in Meter Boxes and on Street Lights

The Public Utilities Department (PUD) has begun the installation of the Advanced Metering Infrastructure (AMI) technology as a new tool to enhance water meter reading accuracy and efficiency, customer service and billing, and to be used by individual accounts to better manage the efficient use of water. **All AMI devices shall be protected per Section 5-2, "Protection", of the 2015 Whitebook.**

AMI technology allows water meters to be read electronically rather than through direct visual inspection by PUD field staff. This will assist PUD staff and customers in managing unusual consumption patterns which could indicate leaks or meter tampering on a customer's property.

Three of the main components of an AMI system are the:

- A. Endpoints, see Photo 1:

**Photo 1**

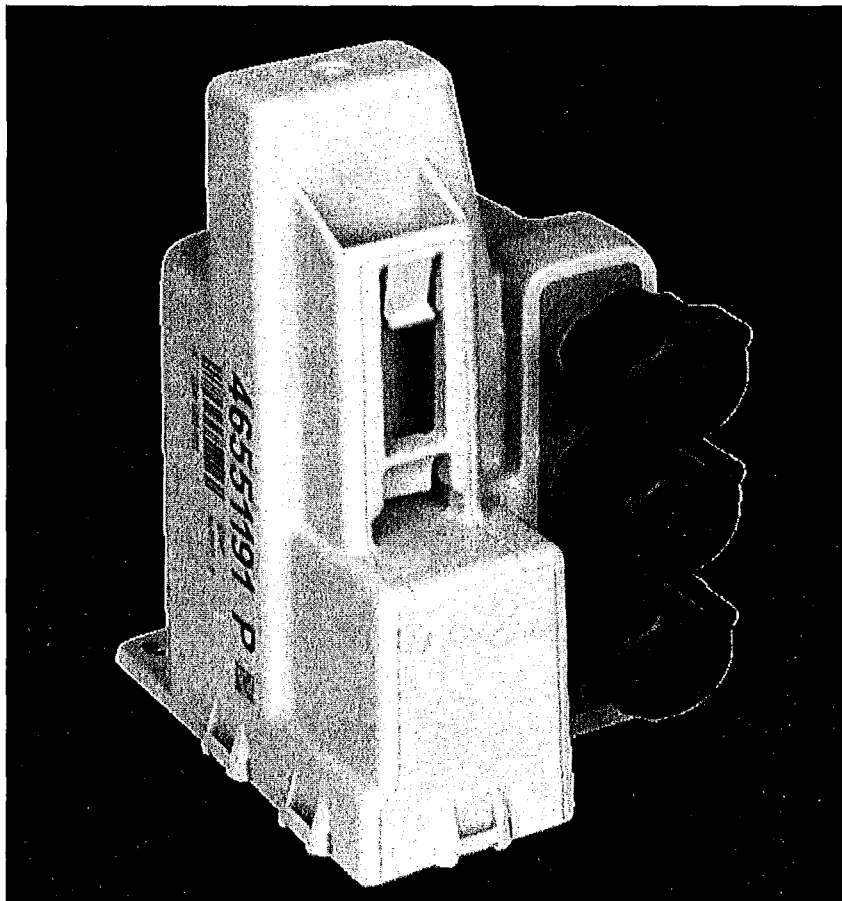

B. AMI Antenna attached to Endpoint (antenna not always required), see Photo 2:

**Photo 2**

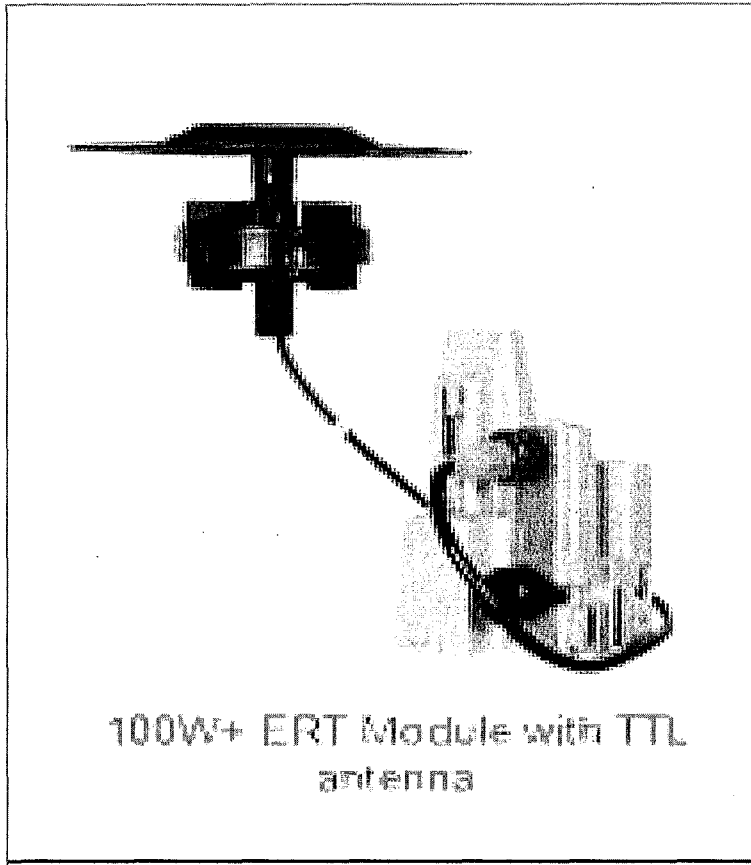

Network Devices, see Photo 3:

**Photo 3**

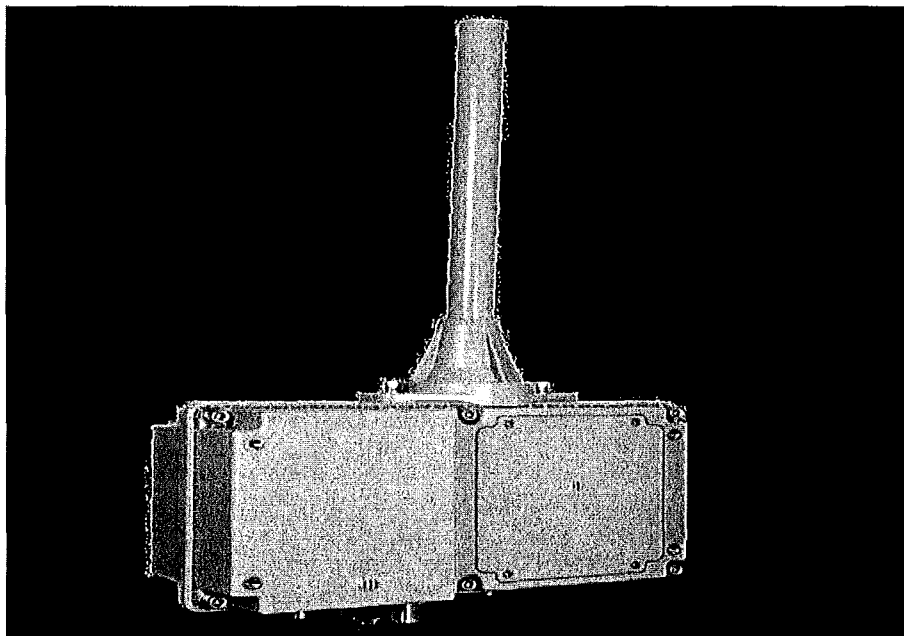

AMI endpoints transmit meter information to the AMI system and will soon be on the vast majority of meters in San Diego. These AMI devices provide interval consumption data to the PUD's Customer Support Division. If these devices are damaged or communication is interrupted, this Division will be alerted of the situation. The endpoints are installed in water meter boxes, coffins, and vaults adjacent to the meter. A separate flat round antenna may also be installed through the meter box lid. This antenna is connected to the endpoint via cable. The following proper installation shall be implemented when removing the lid to avoid damaging the antenna, cable, and/or endpoint. Photo 4 below demonstrates a diagram of the connection:

**Photo 4**

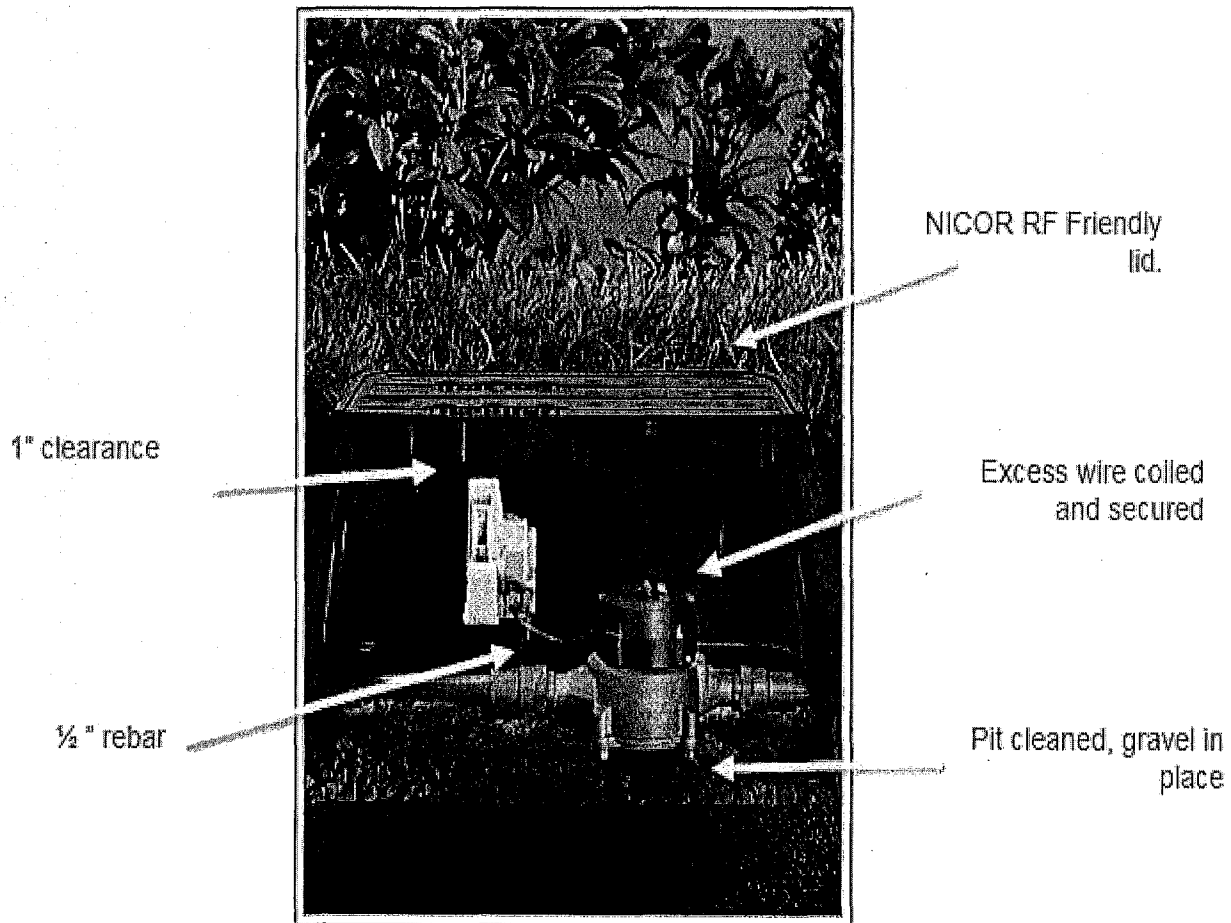

The AMI device ERT/Endpoint/Transmitter shall be positioned and installed as discussed in this Appendix. If the ERT/Endpoint/Transmitter is disturbed, it shall be re-installed and returned to its original installation with the end points pointed upwards as shown below in Photo 5.

**The PUD's code compliance staff will issue citations and invoices to you for any damaged AMI devices that are not re-installed as discussed in the Contract Document**

Photo 5 below shows a typical installation of an AMI endpoint on a water meter.

**Photo 5**

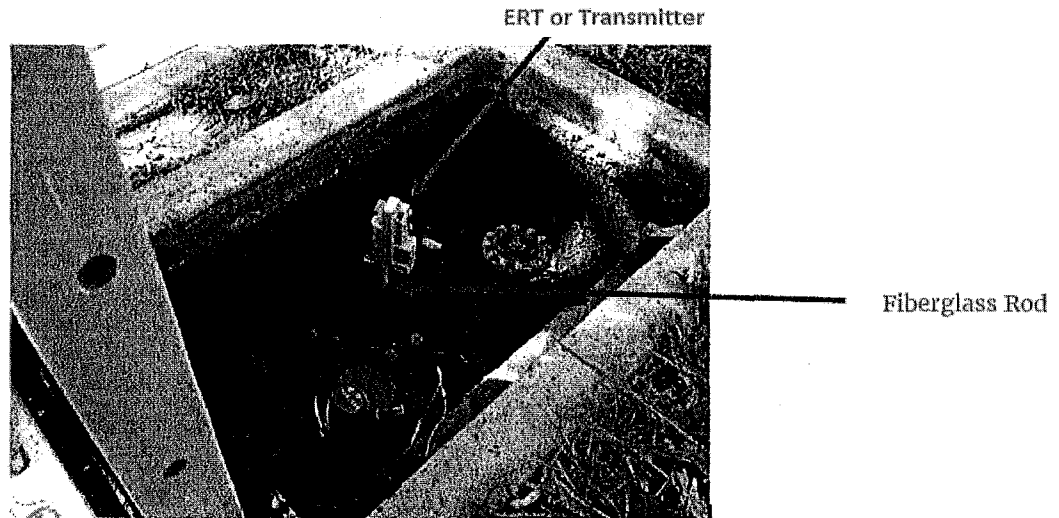
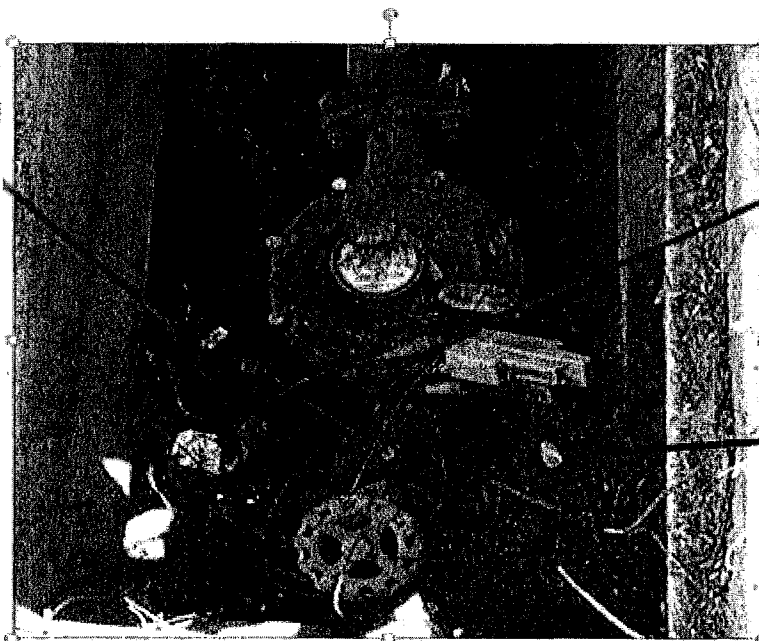

Photo 6 below is an example of disturbance that shall be avoided:

**Photo 6**

The antenna was drilled into the lid and now it is removed



The ERT has been disconnected from the Water Meter

The endpoint is taken off the rod which is the original installation location



**You are responsible when working in and around meter boxes.** If you encounter these endpoints, use proper care and do not disconnect them from the registers on top of the water meter. If the lid has an antenna drilled through, do not change or tamper with the lid and inform the Resident Engineer immediately about the location of that lid. Refer to Photo 7 below:

**Photo 7**



Another component of the AMI system are the Network Devices. The Network Devices are strategically placed units (mainly on street light poles) that collect interval meter reading data from multiple meters for transmission to the Department Control Computer. **If you come across any of these devices on street lights that will be removed or replaced (refer to Photos 8 and 9 below), notify AMI Project Manager Arwa Sayed at (619) 362-0121 immediately.**

Photo 8 shows an installed network device on a street light. On the back of each Network Device is a sticker with contact information. See Photo 9. **Call PUD Water Emergency Repairs at 619-515-3525 if your work will impact these street lights.** These are assets that belong to the City of San Diego and you shall be responsible for any costs of disruption of this network.

**Photo 8**

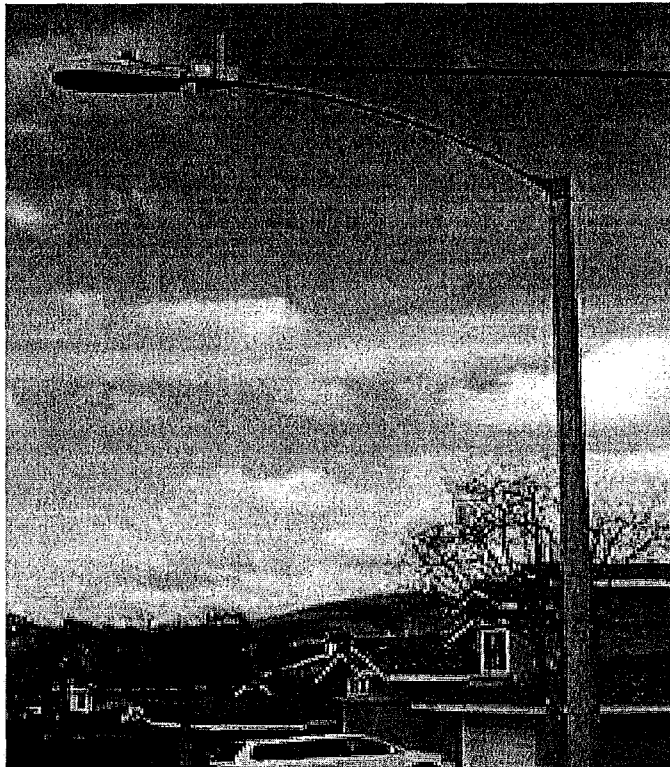

**Network Device**

**Photo 9**



**If you encounter any bad installations, disconnected/broken/buried endpoints, or inadvertently damage any AMI devices or cables, notify the Resident Engineer immediately. The Resident Engineer will then immediately contact the AMI Project Manager, Arwa Sayed, at (619) 362-0121.**