

City of San Diego

CONTRACTOR'S NAME: Hazard Construction Company
ADDRESS: 6465 Marindustry Drive, San Diego, CA 92121
TELEPHONE NO.: 858-200-3660 FAX NO.: 858-453-6034
CITY CONTACT: Brittany Friedenreich, Contract Specialist, Email: BFriedenreic@sandiego.gov
Phone No. (619) 533-3104, Fax No. (619) 533-3633
S. Bliss / H.McIntock / br

BIDDING DOCUMENTS



ORIGINAL



FOR

TORREY PINES ROAD IMPROVEMENTS PHASE 2 AND TORREY PINES ROAD SLOPE RESTORATION

BID NO.: K-18-1550-DBB-3
SAP NO. (WBS/IO/CC): S-15023, S-00877, B-18014
CLIENT DEPARTMENT: 2116
COUNCIL DISTRICT: 1
PROJECT TYPE: IK, IF

THIS CONTRACT WILL BE SUBJECT TO THE FOLLOWING:

- PHASED-FUNDING
- THE CITY'S SUBCONTRACTING PARTICIPATION REQUIREMENTS FOR SLBE PROGRAM
- PREVAILING WAGE RATES: STATE FEDERAL
- APPRENTICESHIP

BID DUE DATE:

2:00 PM

October 26, 2017

CITY OF SAN DIEGO

PUBLIC WORKS CONTRACTS

1010 SECOND AVENUE, 14th FLOOR, MS 614C

SAN DIEGO, CA 92101

ENGINEER OF WORK

The engineering Specifications and Special Provisions contained herein have been prepared by or under the direction of the following Registered Engineer:

Torrey Pines Road Improvements Phase 2 Plan Number 39770

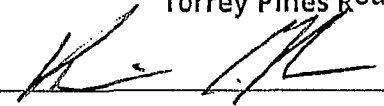
 8/22/17 Seal:
1) Registered Engineer Date



 9/6/17 Seal:
2) For City Engineer Date

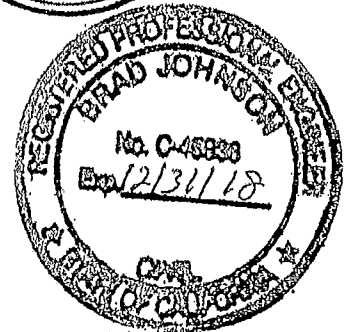

Torrey Pines Road Slope Restoration Plan Number 32132

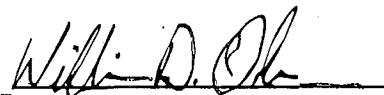
 9/7/17 Seal:
3) Registered Engineer Date

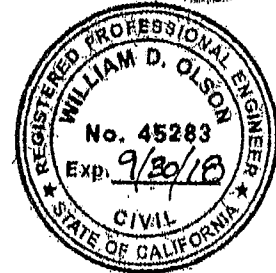

 09-08-17 Seal:
4) For City Engineer Date



TABLE OF CONTENTS

SECTION	PAGE
1. NOTICE INVITING BIDS	4
2. INSTRUCTIONS TO BIDDERS	7
3. PERFORMANCE AND PAYMENT BONDS	17
4. ATTACHMENTS:	
A. SCOPE OF WORK.....	20
B. PHASED FUNDING	22
C. INTENTIONALLY LEFT BLANK	25
D. PREVAILING WAGES.....	26
E. SUPPLEMENTARY SPECIAL PROVISIONS.....	30
1. Appendix A - Mitigated Negative Declaration and CEQA.....	66
2. Appendix B - Fire Hydrant Meter Program.....	127
3. Appendix C - Materials Typically Accepted by Certificate of Compliance.....	141
4. Appendix D - Sample City Invoice with Spend Curve	143
5. Appendix E - Location Map	146
6. Appendix F - Adjacent Projects.....	148
7. Appendix G - Discharge Points and Flow Data.....	150
8. Appendix H - Hazardous Label/Forms	152
9. Appendix I - Sample Archaeology Invoice.....	158
10. Appendix J - Areas of Special Biological Significance Map.....	161
11. Appendix K - Sample of Public Notices	186
12. Appendix L - Advanced Metering Infrastructure (AMI) Device Protection	188
13. Appendix M - Archaeological Report.....	195
14. Appendix N - Geotechnical Report	233
15. Appendix O - Coastal Development Permit and Site Development Permits	346
16. Appendix P - Soil Nail Easements	359
F. INTENTIONALLY LEFT BLANK	369
G. CONTRACT AGREEMENT	370
5. CERTIFICATIONS AND FORMS	373

NOTICE INVITING BIDS

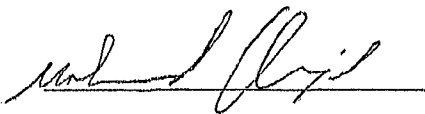
1. **SUMMARY OF WORK:** This is the City of San Diego's (City) solicitation process to acquire Construction services for **Torrey Pines Road Improvements Phase 2 and Torrey Pines Road Slope Restoration**. For additional information refer to Attachment A.
2. **FULL AND OPEN COMPETITION:** This contract is open to full competition and may be bid on by Contractors who are on the City's current Prequalified Contractors' List. For information regarding the Contractors Prequalified list visit the City's web site: <http://www.sandiego.gov>.
3. **ESTIMATED CONSTRUCTION COST:** The City's estimated construction cost for this project is **\$2,930,000**.
4. **BID DUE DATE AND TIME ARE: October 26, 2017 at 2:00 PM**
5. **PREVAILING WAGE RATES APPLY TO THIS CONTRACT:** Refer to Attachment D.
6. **LICENSE REQUIREMENT:** The City has determined that the following licensing classifications are required for this contract: **A**
7. **SUBCONTRACTING PARTICIPATION PERCENTAGES:** Subcontracting participation percentages apply to this contract.
 - 7.1. The City has incorporated **mandatory** SLBE-ELBE subcontractor participation percentages to enhance competition and maximize subcontracting opportunities. For the purpose of achieving the mandatory subcontractor participation percentages, a recommended breakdown of the SLBE and ELBE subcontractor participation percentages based upon certified SLBE and ELBE firms has also been provided to achieve the mandatory subcontractor participation percentages:

1. SLBE participation	14.1%
2. ELBE participation	19.3%
3. Total mandatory participation	33.4%
 - 7.2. The Bid may be declared non-responsive if the Bidder fails to meet the following requirements:
 - 7.2.1. Include SLBE-ELBE certified subcontractors at the overall mandatory participation percentage identified in this document; **OR**
 - 7.2.2. Submit Good Faith Effort documentation, saved in searchable Portable Document Format (PDF) and stored on Compact Disc (CD) or Digital Video Disc (DVD), demonstrating the Bidder made a good faith effort to outreach to and include SLBE-ELBE Subcontractors required in this document within 3 Working Days of the Bid opening if the overall mandatory participation percentage is not met.

8. PRE-BID MEETING:

- 8.1.** Prospective Bidders are **encouraged** to attend the Pre-Bid Meeting. The purpose of the meeting is to discuss the scope of the Project, submittal requirements, the pre-qualification process and any Equal Opportunity Contracting Program requirements and reporting procedures. To request a sign language or oral interpreter for this visit, call the Public Works Contracts Division at (619) 533-3450 at least 5 Working Days prior to the meeting to ensure availability. The Pre-Bid meeting is scheduled as follows:

Date: **October 10, 2017**
Time: **10:00 A.M.**
Location: **1010 Second Avenue, Suite 14th Floor, (Large Conference Room)
1400, San Diego, CA 92101**

Attendance at the Pre-Submittal Meeting will be evidenced by the Bidder's representative's signature on the attendance roster. It is the responsibility of the Bidder's representative to complete and sign the attendance roster.

9. AWARD PROCESS:

- 9.1.** The Award of this contract is contingent upon the Contractor's compliance with all conditions of Award as stated within these documents and within the Notice of Intent to Award.
- 9.2.** Upon acceptance of a Bid, the City will prepare contract documents for execution within approximately 21 days of the date of the Bid opening. The City will then award the Contract within approximately 14 days of receipt of properly signed Contract, bonds, and insurance documents.
- 9.3.** This contract will be deemed executed and effective only upon the signing of the Contract by the Mayor or his designee and approval as to form the City Attorney's Office.
- 9.4.** The low Bid will be determined by Base Bid alone.
- 9.5.** Once the low bid has been determined, the City may, at its sole discretion, award the contract for the Base bid alone.

10. SUBMISSION OF QUESTIONS:

- 10.1.** The Public Works Department is responsible for opening, examining, and evaluating the competitive Bids submitted to the City for the acquisition, construction and completion of any public improvement except when otherwise set forth in these documents. Any questions related to this solicitation shall be submitted to:

Public Works Contracts
1010 Second Avenue, 14th Floor
San Diego, California, 92101
Attention: Brittany Friedenreich

OR:

BFriedenreich@sandiego.gov

- 10.2.** Questions received less than 14 days prior to the date for opening of Bids may not be considered.
- 10.3.** Questions or clarifications deemed by the City to be material shall be answered via issuance of an addendum and posted to the City's online bidding service.
- 10.4.** Only questions answered by formal written addenda shall be binding. Oral and other interpretations or clarifications shall be without legal effect. It is the Bidder's responsibility to be informed of any addenda that have been issued and to include all such information in its Bid.

11. PHASED FUNDING: For Phased Funding Conditions, see Attachment B.

INSTRUCTIONS TO BIDDERS

1. PREQUALIFICATION OF CONTRACTORS:

- 1.1. Contractors submitting a Bid must be pre-qualified for the total amount proposed, including all alternate items, prior to the date of submittal. Bids from contractors who have not been pre-qualified as applicable and Bids that exceed the maximum dollar amount at which contractors are pre-qualified may be deemed **non-responsive** and ineligible for award. Complete information and links to the on-line prequalification application are available at:

<http://www.sandiego.gov/cip/bidopps/prequalification.shtml>

- 1.2. The completed application must be submitted online no later than 2 weeks prior to the bid opening. For additional information or the answer to questions about the prequalification program, contact David Stucky at 619-533-3474 or dstucky@sandiego.gov.
- 1.3. Due to the City's fiduciary requirement to safeguard vendor data, City staff will not be able to provide information regarding contractors' prequalification status over the telephone. Contractors may access real-time information about their prequalification status via their vendor profile on PlanetBids™.

2. ELECTRONIC FORMAT RECEIPT AND OPENING OF BIDS: Bids will be received in electronic format (eBids) EXCLUSIVELY at the City of San Diego's electronic bidding (eBidding) site, at: <http://www.sandiego.gov/cip/bidopps/index.shtml> and are due by the date, and time shown on the cover of this solicitation.

- 2.1. BIDDERS MUST BE PRE-REGISTERED with the City's bidding system and possess a system-assigned Digital ID in order to submit and electronic bid.
- 2.2. The City's bidding system will automatically track information submitted to the site including IP addresses, browsers being used and the URLs from which information was submitted. In addition, the City's bidding system will keep a history of every login instance including the time of login, and other information about the user's computer configuration such as the operating system, browser type, version, and more. Because of these security features, Contractors who disable their browsers' cookies will not be able to log in and use the City's bidding system.
- 2.3. The City's electronic bidding system is responsible for bid tabulations. Upon the bidder's or proposer's entry of their bid, the system will ensure that all required fields are entered. **The system will not accept a bid for which any required information is missing.** This includes all necessary pricing, subcontractor listing(s) and any other essential documentation and supporting materials and forms requested or contained in these solicitation documents.

- 2.4.** BIDS REMAIN SEALED UNTIL BID DEADLINE. eBids are transmitted into the City's bidding system via hypertext transfer protocol secure (https) mechanism using SSL 128-256 bit security certificates issued from Verisign/Thawte which encrypts data being transferred from client to server. Bids submitted prior to the "Bid Due Date and Time" are not available for review by anyone other than the submitter which has until the "Bid Due Date and Time" to change, rescind or retrieve its proposal should it desire to do so.
- 2.5.** BIDS MUST BE SUBMITTED BY BID DUE DATE AND TIME. Once the bid deadline is reached, no further submissions are accepted into the system. Once the Bid Due Date and Time has lapsed, bidders, proposers, the general public, and City staff are able to immediately see the results on line. City staff may then begin reviewing the submissions for responsiveness, EOCP compliance and other issues. The City may require any Bidder to furnish statement of experience, financial responsibility, technical ability, equipment, and references.
- 2.6.** RECAPITULATION OF THE WORK. Bids shall not contain any recapitulation of the Work. Conditional Bids may be rejected as being non-responsive. Alternative proposals will not be considered unless called for.
- 2.7.** BIDS MAY BE WITHDRAWN by the Bidder only up to the bid due date and time.
- 2.7.1.** Important Note: Submission of the electronic bid into the system may not be instantaneous. Due to the speed and capabilities of the user's internet service provider (ISP), bandwidth, computer hardware and other variables, it may take time for the bidder's submission to upload and be received by the City's eBidding system. It is the bidder's sole responsibility to ensure their bids are received on time by the City's eBidding system. The City of San Diego is not responsible for bids that do not arrive by the required date and time.
- 2.8.** ACCESSIBILITY AND AMERICANS WITH DISABILITIES ACT (ADA) COMPLIANCE: To request a copy of this solicitation in an alternative format, contact the Public Works Contract Specialist listed on the cover of this solicitation at least five (5) working days prior to the Bid/Proposal due date to ensure availability.

3. ELECTRONIC BID SUBMISSIONS CARRY FULL FORCE AND EFFECT

- 3.1.** The bidder, by submitting its electronic bid, acknowledges that doing so carries the same force and full legal effect as a paper submission with a longhand (wet) signature.
- 3.2.** By submitting an electronic bid, the bidder certifies that the bidder has thoroughly examined and understands the entire Contract Documents (which consist of the plans and specifications, drawings, forms, affidavits and the solicitation documents), and that by submitting the eBid as its bid proposal, the bidder acknowledges, agrees to and is bound by the entire Contract Documents, including any addenda issued thereto, and incorporated by reference in the Contract Documents.
- 3.3.** The Bidder, by submitting its electronic bid, agrees to and certifies under penalty of perjury under the laws of the State of California, that the certification, forms and affidavits submitted as part of this bid are true and correct.
- 3.4.** The Bidder agrees to the construction of the project as described in Attachment "A-Scope of Work" for the City of San Diego, in accordance with the requirements set forth herein for the electronically submitted prices. The Bidder guarantees the Contract Price for a period of 120 days (90 days for federally funded contracts and contracts valued at \$500,000 or less) from the date of Bid opening. The duration of the Contract Price guarantee shall be extended by the number of days required for the City to obtain all items necessary to fulfill all conditions precedent.

- 4. BIDS ARE PUBLIC RECORDS:** Upon receipt by the City, Bids shall become public records subject to public disclosure. It is the responsibility of the respondent to clearly identify any confidential, proprietary, trade secret or otherwise legally privileged information contained within the Bid. General references to sections of the California Public Records Act (PRA) will not suffice. If the Contractor does not provide applicable case law that clearly establishes that the requested information is exempt from the disclosure requirements of the PRA, the City shall be free to release the information when required in accordance with the PRA, pursuant to any other applicable law, or by order of any court or government agency, and the Contractor will hold the City harmless for release of this information.

5. CONTRACTOR REGISTRATION AND ELECTRONIC REPORTING SYSTEM:

- 5.1.** **Prior** to the Award of the Contract or Task Order, you and your Subcontractors and Suppliers must register with the City's web-based vendor registration and bid management system. For additional information go to:

<http://www.sandiego.gov/purchasing/bids-contracts/vendorreg.shtml>.
- 5.2.** The City may not award the contract until registration of all subcontractors and suppliers is complete. In the event this requirement is not met within the time frame specified in the Notice of Intent to Award letter, the City reserves the right to rescind

the Notice of Award / Intent to Award and to make the award to the next responsive and responsible bidder / proposer.

6. **JOINT VENTURE CONTRACTORS:** Provide a copy of the Joint Venture agreement and the Joint Venture license to the City within 10 Working Days after receiving the Contract forms. See 2-1.1.2, "Joint Venture Contractors" in The WHITEBOOK for details.
7. **PREVAILING WAGE RATES WILL APPLY:** Refer to Attachment D.
8. **SUBCONTRACTING PARTICIPATION PERCENTAGES:** Subcontracting participation percentages apply to this contract. Refer to Attachment E.
9. **INSURANCE REQUIREMENTS:**
 - 9.1. All certificates of insurance and endorsements required by the contract are to be provided upon issuance of the City's Notice of Intent to Award letter.
 - 9.2. Refer to sections 7-3, "LIABILITY INSURANCE", and 7-4, "WORKERS' COMPENSATION INSURANCE" of the Supplementary Special Provisions (SSP) for the insurance requirements which must be met.
10. **REFERENCE STANDARDS:** Except as otherwise noted or specified, the Work shall be completed in accordance with the following standards:

Title	Edition	Document Number
Standard Specifications for Public Works Construction ("The GREENBOOK") http://www.greenbookspecs.org/	2015	PWPI070116-01
City of San Diego Standard Specifications for Public Works Construction ("The WHITEBOOK")* https://www.sandiego.gov/publicworks/edocref/greenbook	2015	PWPI070116-02
City of San Diego Standard Drawings* https://www.sandiego.gov/publicworks/edocref/standarddraw	2016	PWPI070116-03
Citywide Computer Aided Design and Drafting (CADD) Standards https://www.sandiego.gov/publicworks/edocref/drawings	2016	PWPI092816-04
California Department of Transportation (CALTRANS) Standard Specifications - http://www.dot.ca.gov/des/oe/construction-contract-standards.html	2015	PWPI092816-05
CALTRANS Standard Plans http://www.dot.ca.gov/des/oe/construction-contract-standards.html	2015	PWPI092816-06

Title	Edition	Document Number
California Manual on Uniform Traffic Control Devices Revision 1 (CA MUTCD Rev 1) - http://www.dot.ca.gov/trafficops/camutcd/	2014	PWPIO92816-07
NOTE: *Available online under Engineering Documents and References at: http://www.sandiego.gov/publicworks/edocref/index.shtml		

11. **CITY'S RESPONSES AND ADDENDA:** The City, at its discretion, may respond to any or all questions submitted in writing via the City's eBidding web site in the **form of an addendum**. No other responses to questions, oral or written shall be of any force or effect with respect to this solicitation. The changes to the Contract Documents through addenda are made effective as though originally issued with the Bid. The Bidders shall acknowledge the receipt of Addenda at the time of bid submission.
12. **CITY'S RIGHTS RESERVED:** The City reserves the right to cancel the Notice Inviting Bids at any time, and further reserves the right to reject submitted Bids, without giving any reason for such action, at its sole discretion and without liability. Costs incurred by the Bidder(s) as a result of preparing Bids under the Notice Inviting Bids shall be the sole responsibility of each bidder. The Notice Inviting Bids creates or imposes no obligation upon the City to enter a contract.
13. **CONTRACT PRICING:** This solicitation is for a Lump Sum contract with Unit Price provisions as set forth herein. The Bidder agrees to perform construction services for the City of San Diego in accordance with these contract documents for the prices listed below. The Bidder further agrees to guarantee the Contract Price for a period of 120 days from the date of Bid opening. The duration of the Contract Price guarantee may be extended, by mutual consent of the parties, by the number of days required for the City to obtain all items necessary to fulfill all contractual conditions.
14. **SUBCONTRACTOR INFORMATION:**
- 14.1. **Listing of Subcontractors.** In accordance with the requirements provided in the "Subletting and Subcontracting Fair Practices Act" of the California Public Contract Code, the Bidder shall provide the **NAME** and **ADDRESS** of each Subcontractor who will perform work, labor, render services or who specially fabricates and installs a portion [type] of the work or improvement, in an amount in excess of 0.5% of the Contractor's total Bid. The Bidder shall also state within the description, whether the subcontractor is a **CONSTRUCTOR, CONSULTANT** or **SUPPLIER**. The Bidder shall further state within the description, the **PORTION** of the work which will be performed by each subcontractor under this Contract. The Contractor shall list only one Subcontractor for each portion of the Work. The **DOLLAR VALUE** of the total Bid to be performed shall be stated for all subcontractors listed. Failure to comply with this requirement may result in the Bid being rejected as **non-responsive** and ineligible for

award. The Bidder's attention is directed to the Special Provisions - General; Paragraph 2-3, "Subcontracts", which stipulates the percent of the Work to be performed with the Bidders' own forces. The Bidder shall list all SLBE, ELBE, DBE, DVBE, MBE, WBE, OBE, SDB, WoSB, HUBZone, and SDVOSB Subcontractors for which Bidders are seeking recognition towards achieving any mandatory, voluntary (or both) subcontracting participation goals.

- 14.2. Listing of Suppliers.** Any Bidder seeking the recognition of Suppliers of equipment, materials, or supplies obtained from third party Suppliers towards achieving any mandatory or voluntary (or both) subcontracting participation goals shall provide, at a minimum, the **NAME, LOCATION (CITY)** and the **DOLLAR VALUE** of each supplier. The Bidder will be credited up to 60% of the amount to be paid to the Suppliers for materials and supplies unless vendor manufactures or substantially alters materials and supplies, in which case, 100% will be credited. The Bidder is to indicate within the description whether the listed firm is a supplier or manufacturer. If no indication is provided, the listed firm will be credited at 60% of the listed dollar value for purposes of calculating the Subcontractor Participation Percentage.
- 14.3. Listing of Subcontractors or Suppliers for Alternates.** For subcontractors or suppliers to be used on additive or deductive alternate items, in addition to the above requirements, bidder shall further note "ALTERNATE" and alternate item number within the description.
- 15. SUBMITTAL OF "OR EQUAL" ITEMS:** See Section 4-1.6, "Trade Names or Equals" in The WHITEBOOK and as amended in the SSP.
- 16. AWARD:**

 - 16.1.** The Award of this contract is contingent upon the Contractor's compliance with all conditions precedent to Award.
 - 16.2.** Upon acceptance of a Bid, the City will prepare contract documents for execution within approximately 21 days of the date of the Bid opening and award the Contract approximately within 7 days of receipt of properly executed Contract, bonds, and insurance documents.
 - 16.3.** This contract will be deemed executed and effective only upon the signing of the Contract by the Mayor or his designee and approval as to form the City Attorney's Office.
- 17. SUBCONTRACT LIMITATIONS:** The Bidder's attention is directed to Standard Specifications for Public Works Construction, Section 2-3, "SUBCONTRACTS" in The GREENBOOK and as amended in the SSP which requires the Contractor to self-perform not less than the specified amount. Failure to comply with this requirement shall render the bid **non-responsive** and ineligible for award.

- 18. AVAILABILITY OF PLANS AND SPECIFICATIONS:** Contract Documents may be obtained by visiting the City's website: <http://www.sandiego.gov/cip/>. Plans and Specifications for this contract are also available for review in the office of the City Clerk or Public Works Contracts.
- 19. ONLY ONE BID PER CONTRACTOR SHALL BE ACCEPTED:** No person, firm, or corporation shall be allowed to make, file, or be interested in more than one (1) Bid for the same work unless alternate Bids are called for. A person, firm or corporation who has submitted a sub-proposal to a Bidder, or who has quoted prices on materials to a Bidder, is not hereby disqualified from submitting a sub-proposal or quoting prices to other Bidders or from submitting a Bid in its own behalf. Any Bidder who submits more than one bid will result in the rejection of all bids submitted.
- 20. SAN DIEGO BUSINESS TAX CERTIFICATE:** The Contractor and Subcontractors, not already having a City of San Diego Business Tax Certificate for the work contemplated shall secure the appropriate certificate from the City Treasurer, Civic Center Plaza, First floor and submit to the Contract Specialist upon request or as specified in the Contract Documents. Tax Identification numbers for both the Bidder and the listed Subcontractors must be submitted on the City provided forms within these documents.
- 21. BIDDER'S GUARANTEE OF GOOD FAITH (BID SECURITY) FOR DESIGN-BID-BUILD CONTRACTS:**
- 21.1.** For bids \$250,000 and above, bidders shall submit Bid Security at bid time. Bid Security shall be in one of the following forms: a cashier's check, or a properly certified check upon some responsible bank; or an approved corporate surety bond payable to the City of San Diego for an amount of not less than 10% of the total bid amount.
- 21.2.** This check or bond, and the monies represented thereby, will be held by the City as a guarantee that the Bidder, if awarded the contract, will in good faith enter into the contract and furnish the required final performance and payment bonds.
- 21.3.** The Bidder agrees that in the event of the Bidder's failure to execute this contract and provide the required final bonds, the money represented by the cashier's or certified check will remain the property of the City; and the Surety agrees that it will pay to the City the damages, not exceeding the sum of 10% of the amount of the Bid, that the City may suffer as a result of such failure.
- 21.4.** At the time of bid submission, bidders must upload and submit an electronic PDF copy of the aforementioned bid security. Whether in the form of a cashier's check, a properly certified check or an approved corporate surety bond payable to the City of San Diego, the bid security must be uploaded to the City's eBidding system. Within twenty-four (24) hours after the bid due date and time, the first five (5) apparent low bidders must provide the City with the original bid security.

21.5. Failure to submit the electronic version of the bid security at the time of bid submission AND failure to provide the original within twenty-four (24) hours may cause the bid to be rejected and deemed **non-responsive**.

22. AWARD OF CONTRACT OR REJECTION OF BIDS:

22.1. This contract may be awarded to the lowest responsible and reliable Bidder.

22.2. Bidders shall complete ALL eBid forms as required by this solicitation. Incomplete eBids will not be accepted.

22.3. The City reserves the right to reject any or all Bids, to waive any informality or technicality in Bids received, and to waive any requirements of these specifications as to bidding procedure.

22.4. Bidders will not be released on account of their errors of judgment. Bidders may be released only upon receipt by the City within 3 Working Days of the bid opening, written notice from the Bidder which shows proof of honest, credible, clerical error of a material nature, free from fraud or fraudulent intent; and of evidence that reasonable care was observed in the preparation of the Bid.

22.5. A bidder who is not selected for contract award may protest the award of a contract to another bidder by submitting a written protest in accordance with the San Diego Municipal Code.

22.6. The City of San Diego will not discriminate in the award of contracts with regard to race, religion creed, color, national origin, ancestry, physical handicap, marital status, sex or age.

22.7. Each Bid package properly signed as required by these specifications shall constitute a firm offer which may be accepted by the City within the time specified herein.

22.8. The City reserves the right to evaluate all Bids and determine the lowest Bidder on the basis of the base bid and any proposed alternates or options as detailed herein.

23. BID RESULTS:

23.1. The availability of the bids on the City's eBidding system shall constitute the public announcement of the apparent low bidder. In the event that the apparent low bidder is subsequently deemed non-responsive or non-responsible, a notation of such will be made on the eBidding system. The new ranking and apparent low bidder will be adjusted accordingly.

23.2. To obtain the bid results, view the results on the City's web site, or request the results by U.S. mail and provide a self-addressed, stamped envelope. If requesting by mail,

be sure to reference the bid name and number. The bid tabulations will be mailed to you upon their completion. The results will not be given over the telephone.

24. THE CONTRACT:

- 24.1.** The Bidder to whom award is made shall execute a written contract with the City of San Diego and furnish good and approved bonds and insurance certificates specified by the City within 14 days after receipt by Bidder of a form of contract for execution unless an extension of time is granted to the Bidder in writing.
- 24.2.** If the Bidder takes longer than 14 days to fulfill these requirements, then the additional time taken shall be added to the Bid guarantee. The Contract shall be made in the form adopted by the City, which includes the provision that no claim or suit whatsoever shall be made or brought by Contractor against any officer, agent, or employee of the City for or on account of anything done or omitted to be done in connection with this contract, nor shall any such officer, agent, or employee be liable hereunder.
- 24.3.** If the Bidder to whom the award is made fails to enter into the contract as herein provided, the award may be annulled and the Bidder's Guarantee of Good Faith will be subject to forfeiture. An award may be made to the next lowest responsible and reliable Bidder who shall fulfill every stipulation embraced herein as if it were the party to whom the first award was made.
- 24.4.** Pursuant to the San Diego City Charter section 94, the City may only award a public works contract to the lowest responsible and reliable Bidder. The City will require the Apparent Low Bidder to (i) submit information to determine the Bidder's responsibility and reliability, (ii) execute the Contract in form provided by the City, and (iii) furnish good and approved bonds and insurance certificates specified by the City within 14 Days, unless otherwise approved by the City, in writing after the Bidder receives notification from the City, designating the Bidder as the Apparent Low Bidder and formally requesting the above mentioned items.
- 24.5.** The award of the Contract is contingent upon the satisfactory completion of the above-mentioned items and becomes effective upon the signing of the Contract by the Mayor or designee and approval as to form the City Attorney's Office. If the Apparent Low Bidder does not execute the Contract or submit required documents and information, the City may award the Contract to the next lowest responsible and reliable Bidder who shall fulfill every condition precedent to award. A corporation designated as the Apparent Low Bidder shall furnish evidence of its corporate existence and evidence that the officer signing the Contract and bond for the corporation is duly authorized to do so.

25. EXAMINATION OF PLANS, SPECIFICATIONS, AND SITE OF WORK: The Bidder shall examine carefully the Project Site, the Plans and Specifications, other materials as described in the Special Provisions, Section 2-7, and the proposal forms (e.g., Bidding Documents). The submission of a Bid shall be conclusive evidence that the Bidder has investigated and is satisfied as to the conditions to be encountered, as to the character, quality, and scope of Work, the quantities of materials to be furnished, and as to the requirements of the Bidding Documents Proposal, Plans, and Specifications.

26. CITY STANDARD PROVISIONS: This contract is subject to the following standard provisions. See The WHITEBOOK for details.

26.1. The City of San Diego Resolution No. R-277952 adopted on May 20, 1991 for a Drug-Free Workplace.

26.2. The City of San Diego Resolution No. R-282153 adopted on June 14, 1993 related to the Americans with Disabilities Act.

26.3. The City of San Diego Municipal Code §22.3004 for Contractor Standards.

26.4. The City of San Diego's Labor Compliance Program and the State of California Labor Code §§1771.5(b) and 1776.

26.5. Sections 1777.5, 1777.6, and 1777.7 of the State of California Labor Code concerning the employment of apprentices by contractors and subcontractors performing public works contracts.

26.6. The City's Equal Benefits Ordinance (EBO), Chapter 2, Article 2, Division 43 of The San Diego Municipal Code (SDMC).

26.7. The City's Information Security Policy (ISP) as defined in the City's Administrative Regulation 90.63.

27. PRE-AWARD ACTIVITIES:

27.1. The contractor selected by the City to execute a contract for this Work shall submit the required documentation as specified in the herein and in the Notice of Award. Failure to provide the information as specified may result in the Bid being rejected as **non-responsive**.

27.2. The decision that bid is non-responsive for failure to provide the information required within the time specified shall be at the sole discretion of the City.

PERFORMANCE BOND, LABOR AND MATERIALMEN'S BOND

FAITHFUL PERFORMANCE BOND AND LABOR AND MATERIALMEN'S BOND:

Hazard Construction Company, a corporation, as principal, and
Nationwide Mutual Insurance Company, a corporation authorized to do
business in the State of California, as Surety, hereby obligate themselves, their successors and
assigns, jointly and severally, to The City of San Diego a municipal corporation in the
sum of Two Million Six Hundred Ninety Two Thousand Two Hundred Thirty Five Dollars and
Zero Cents (\$2,692,235.00) for the faithful performance of the annexed contract, in the sum
of Two Million Six Hundred Ninety Two Thousand Two Hundred Thirty Five Dollars
and Zero Cents (\$2,692,235.00) for the benefit of laborers and materialmen designated
below.

Conditions:

If the Principal shall faithfully perform the annexed contract with the City of San Diego,
California, then the obligation herein with respect to a faithful performance shall be void; otherwise it
shall remain in full force.

If the Principal shall promptly pay all persons, firms and corporations furnishing materials for
or performing labor in the execution of this contract, and shall pay all amounts due under the
California Unemployment Insurance Act then the obligation herein with respect to laborers and
materialmen shall be void; otherwise it shall remain in full force.

The obligation herein with respect to laborers and materialmen shall inure to the benefit of
all persons, firms and corporations entitled to file claims under the provisions of Article 2. Claimants,
(iii) public works of improvement commencing with Civil Code Section 9100 of the Civil Code of the
State of California.

Changes in the terms of the annexed contract or specifications accompanying same or
referred to therein shall not affect the Surety's obligation on this bond, and the Surety hereby
waives notice of same.

The Surety shall pay reasonable attorney's fees should suit be brought to enforce the provisions of
this bond.

PERFORMANCE BOND, LABOR AND MATERIALMEN'S BOND (continued)

Dated November 9, 2017

Approved as to Form

Hazard Construction Company

Principal

By 

JASON A. MORDHORST, PRESIDENT

Printed Name of Person Signing for Principal

Mara W. Elliott, City Attorney

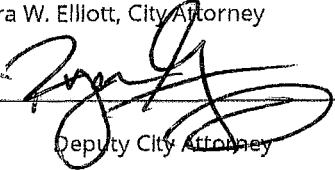
By 

Deputy City Attorney

Nationwide Mutual Insurance Company

Surety

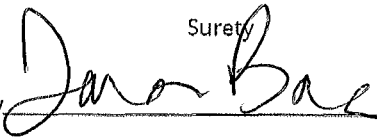
By 

Tara Bacon Attorney-In-fact

Approved:

By 

Stephen Samara
Principal Contract Specialist
Public Works Department

9380 Station Street, Suite 100

Local Address of Surety

Lone Tree, CO 80124

Local Address (City, State) of Surety

(720) 889-1109

Local Telephone No. of Surety

Premium \$ 24,230.00

Bond No. SNN4007255

CALIFORNIA ALL-PURPOSE ACKNOWLEDGMENT

A notary public or other officer completing this certificate verifies only the identity of the individual who signed the document, to which this certificate is attached, and not the truthfulness, accuracy or validity of that document.

State of California

County of San Diego

On November 17, 2017 before me, Apryle M. Briede, Notary Public
Date NAME, TITLE OF OFFICER - E.G. AJANE DOE, NOTARY PUBLIC

personally appeared Jason A. Mordhorst
NAME(S) OF SIGNER(S)

who proved to me on the basis of satisfactory evidence to be the person(s) whose name(s) is/are subscribed to the within instrument and acknowledged to me that he/she/they executed the same in his/her/their authorized capacity(ies) and that by his/her/their signature(s) on the instrument the person(s), or the entity upon behalf of which the person(s) acted, executed the instrument.

I certify under PENALTY OF PERJURY under the laws of the State of California that the foregoing paragraph is true and correct.

WITNESS my hand and official seal.

Apryle M. Briede
NOTARY PUBLIC SIGNATURE



CALIFORNIA ALL-PURPOSE ACKNOWLEDGMENT
CIVIL CODE § 1189

A notary public or other officer completing this certificate verifies only the identity of the individual who signed the document to which this certificate is attached, and not the truthfulness, accuracy, or validity of that document.

State of California
County of San Diego)

On November 9, 2017 before me, Diana Kai Murphy, Notary Public
(insert name and title of the officer)

personally appeared Tara Bacon,
who proved to me on the basis of satisfactory evidence to be the person(s) whose name(s) is/are
subscribed to the within instrument and acknowledged to me that he/she/they executed the same in
his/her/their authorized capacity(ies), and that by his/her/their signature(s) on the instrument the
person(s), or the entity upon behalf of which the person(s) acted, executed the instrument.

I certify under PENALTY OF PERJURY under the laws of the State of California that the foregoing
paragraph is true and correct.

WITNESS my hand and official seal.

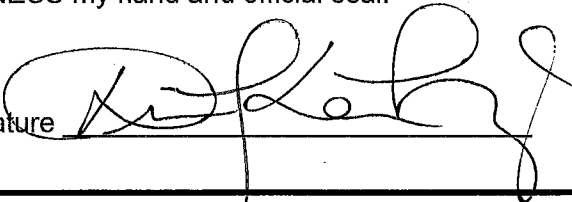
Signature  (Seal)



Power of Attorney

KNOW ALL MEN BY THESE PRESENTS THAT:

Nationwide Mutual Insurance Company, an Ohio corporation hereinafter referred to as the "Company" and does hereby make, constitute and appoint:

Minna Huovila, Tara Bacon, Kyle King, Dale Gene Harshaw

each in their individual capacity, its true and lawful attorney-in-fact, with full power and authority to sign, seal, and execute on its behalf any and all bonds and undertakings, and other obligatory instruments of similar nature, in penalties not exceeding the sum of

UNLIMITED

and to bind the Company thereby, as fully and to the same extent as if such instruments were signed by the duly authorized officers of the Company; and all acts of said Attorney pursuant to the authority given are hereby ratified and confirmed.

This power of attorney is made and executed pursuant to and by authority of the following resolution duly adopted by the board of directors of the Company:

"RESOLVED, that the president, or any vice president be, and each hereby is, authorized and empowered to appoint attorneys-in-fact of the Company, and to authorize them to execute and deliver on behalf of the Company any and all bonds, forms, applications, memorandums, undertakings, recognizances, transfers, contracts of indemnity, policies, contracts guaranteeing the fidelity of persons holding positions of public or private trust, and other writings obligatory in nature that the business of the Company may require; and to modify or revoke, with or without cause, any such appointment or authority; provided, however, that the authority granted hereby shall in no way limit the authority of other duly authorized agents to sign and countersign any of said documents on behalf of the Company."

"RESOLVED FURTHER, that such attorneys-in-fact shall have full power and authority to execute and deliver any and all such documents and to bind the Company subject to the terms and limitations of the power of attorney issued to them, and to affix the seal of the Company thereto; provided, however, that said seal shall not be necessary for the validity of any such documents."

This power of attorney is signed and sealed under and by the following bylaws duly adopted by the board of directors of the Company.

Execution of Instruments. Any vice president, any assistant secretary or any assistant treasurer shall have the power and authority to sign or attest all approved documents, instruments, contracts, or other papers in connection with the operation of the business of the company in addition to the chairman of the board, the chief executive officer, president, treasurer or secretary; provided, however, the signature of any of them may be printed, engraved, or stamped on any approved document, contract, instrument, or other papers of the Company.

IN WITNESS WHEREOF, the Company has caused this instrument to be sealed and duly attested by the signature of its officer the 1st day of May, 2017.

[Handwritten signature of Antonio C. Albanese]

Antonio C. Albanese, Vice President of Nationwide Mutual Insurance Company



ACKNOWLEDGMENT

STATE OF NEW YORK, COUNTY OF NEW YORK: ss
On this 1st day of May, 2017, before me came the above-named officer for the Company aforesaid, to me personally known to be the officer described in and who executed the preceding instrument, and he acknowledged the execution of the same, and being by me duly sworn, deposes and says, that he is the officer of the Company aforesaid, that the seal affixed hereto is the corporate seal of said Company, and the said corporate seal and his signature were duly affixed and subscribed to said instrument by the authority and direction of said Company.

BARRY T. BASSIS
Notary Public, State of New York
No. 02BA4656400
Qualified in New York County
Commission Expires April 30, 2019

[Handwritten signature of Barry T. Bassis]
Notary Public
My Commission Expires
April 30, 2019

CERTIFICATE

I, Laura B. Guy, Assistant Secretary of the Company, do hereby certify that the foregoing is a full, true and correct copy of the original power of attorney issued by the Company; that the resolution included therein is a true and correct transcript from the minutes of the meetings of the boards of directors and the same has not been revoked or amended in any manner; that said Antonio C. Albanese was on the date of the execution of the foregoing power of attorney the duly elected officer of the Company, and the corporate seal and his signature as officer were duly affixed and subscribed to the said instrument by the authority of said board of directors; and the foregoing power of attorney is still in full force and effect.

IN WITNESS WHEREOF, I have hereunto subscribed my name as Assistant Secretary, and affixed the corporate seal of said Company this 9th day of November, 2017.

[Handwritten signature of Laura B. Guy]
Assistant Secretary

ATTACHMENTS

ATTACHMENT A
SCOPE OF WORK

SCOPE OF WORK

1. **SCOPE OF WORK:** The contract scope of work includes the following:
 - 1.1. **Torrey Pines Road Improvements Phase 2** scope of work includes the following: 1) Installation of new sidewalk, retaining curb, and walls on the south side of Torrey Pines Road between Hillside Drive and Amalfi Street. 2) Installation of a pedestrian crossing on Torrey Pines Road just west of Princess Drive utilizing a HAWK (Hybrid Actuated Walk Beacon) with street lighting and crosswalk systems. 3) Asphalt concrete overlay with striping of buffered bike lanes along Torrey Pines Road from La Jolla Shores Drive to Princess Drive. 4) Installation of a flush stamped and painted asphalt median between Roseland Drive and Hillside Drive.
 - 1.1.1. The Work shall be performed in accordance with:
 - 1.1.1.1. The Notice Inviting Bids and Plans numbered **39770-01-D** through **39770-19-D**, and Traffic Control Plans numbered **39770-T01** through **39770-T08**, inclusive.
 - 1.2. **Torrey Pines Road Slope Restoration** scope of work will include an excavation at the toe of the slope to achieve the required space for the sidewalk, removal of sloughing soil and debris off of slope face, and installation of permanent soil-nails wall with an outer boulderscape or rock carve surface. The soil-nails, up to 40 feet in length, will be installed into the slope at an angle of approximately 15 degrees below horizontal. Horizontal and vertical spacing of the soil-nail will be approximately 6 feet. Roughly 265 soil-nails will be installed to construct the permanent wall.
 - 1.2.1. The Work shall be performed in accordance with:
 - 1.2.1.1. The Notice Inviting Bids and Plans numbered **32132-01-D** through **32132-14-D**, inclusive.
2. **ESTIMATED CONSTRUCTION COST:** The City's estimated construction cost for this project is **\$2,930,000**.
3. **LOCATION OF WORK:** The location of the Work is as follows:

See Location Map per Appendix E.
4. **CONTRACT TIME:** The Contract Time for completion of the Work, shall be **130 Working Days**.

ATTACHMENT B
PHASED FUNDING

PHASED FUNDING PROVISIONS

1. PRE-AWARD

1.1. Within 10 Working Days after the Bid Opening date, the Apparent Low Bidder must contact the Project Manager to discuss fund availability for each phase and shall also submit the following:

1.1.1. Construction Cost Loaded Schedule in accordance with 6-1, "CONSTRUCTION SCHEDULE AND COMMENCEMENT OF THE WORK" and 9-3, "PAYMENT.

1.2. Your failure to perform any of the following may result cancelling your award of the Contract:

1.2.1. Meeting with the City's Project Manager to discuss the Phased Funding Schedule.

1.2.2. Agreeing to a Phased Funding Schedule within 10 Working Days after meeting with the City's Project Manager.

2. POST-AWARD

2.1. Do not start any construction activities for the next phase until the NTP has been issued by the Engineer. The City will issue separate Notice to Proceed (NTP) documents for each phase.

2.2. If requested, the Engineer may issue the NTP for the next phase before the end of the current approved phase.

PHASED FUNDING SCHEDULE AGREEMENT

The particulars left blank in this sample, such as the total number of phases and the amounts assigned to each phase, will be completed with funding specific information from the Pre-Award Schedule and Construction Cost Loaded Schedule submitted to and approved by the City.

BID NUMBER: K-18-1550-DBB-3

CONTRACT OR TASK TITLE: Torrey Pines Road Phase 2 and Torrey Pines Road Slope Restoration

CONTRACTOR: Hazard Construction Company

Funding Phase	Phase Description	Phase Start	Phase Finish	Not-to-Exceed Amount
1	All work shown in Contract Documents K-18-1550-DBB-3 for Torrey Pines Road Phase 2 and Torrey Pines Road Slope Restoration	January 2, 2018	May 25, 2018	\$2,692,235.00
Contract Total				\$2,692,235.00

Notes:

- 1) WHITEBOOK section 9-3.6, "Phased Funding Compensation" applies.
- 2) The total of all funding phases shall be equal to the TOTAL BID PRICE as shown on BID SCHEDULE 1 - PRICES.
- 3) This PHASED FUNDING SCHEDULE AGREEMENT will be incorporated into the CONTRACT and shall only be revised by written modifications to the CONTRACT.

CITY OF SAN DIEGO

PRINT NAME: DINO CIAFRE
Construction Manager

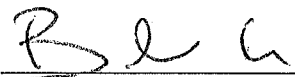
Signature: 

Date: 10/14/17

PRINT NAME: Steven Bliss
Project Manager

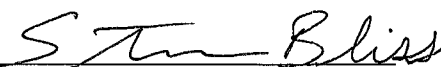
Signature: 

Date: 11/08/2017

CONTRACTOR

PRINT NAME: HAZARD CONSTRUCTION COMPANY

Title: JASON A. MORPHORST, PRESIDENT

Signature: 

Date: 11/29/17

ATTACHMENT C
INTENTIONALLY LEFT BLANK

ATTACHMENT D
PREVAILING WAGES

This comes to inform you that, pursuant to changes resulting from California Senate Bill 96, the City will be amending the terms of your upcoming contract to reflect the changes as follows:

Replace the Attachment D that was included in the solicitation with the revised Attachment D attached hereto.

Please complete below, sign and return to me at your earliest convenience.

K-18-1550-DBB-3
RFP/Bid Number

HAZARD CONSTRUCTION COMPANY
Firm Name

Torrey Pines
Project Name

JASON A. RICHENHORST, PRESIDENT
Print Name/Title

[Signature]
Signature

cc: Stephen Samara, Principal Contract Specialist, Public Works Department
Rosa Isela Riego, Senior Contract Specialist, Public Works Department
File

Attachment

ATTACHMENT D

PREVAILING WAGES

1. **PREVAILING WAGE RATES:** Pursuant to San Diego Municipal Code section 22.3019, construction, alteration, demolition, repair and maintenance work performed under this Contract is subject to State prevailing wage laws. For construction work performed under this Contract cumulatively exceeding \$25,000 and for alteration, demolition, repair and maintenance work performed under this Contract cumulatively exceeding \$15,000, the Contractor and its subcontractors shall comply with State prevailing wage laws including, but not limited to, the requirements listed below.

~~1.1.~~ **Compliance with Prevailing Wage Requirements.** Pursuant to sections 1720 through 1861 of the California Labor Code, the Contractor and its subcontractors shall ensure that all workers who perform work under this Contract are paid not less than the prevailing rate of per diem wages as determined by the Director of the California Department of Industrial Relations (DIR). This includes work performed during the design and preconstruction phases of construction including, but not limited to, inspection and land surveying work.

1.1.1. Copies of such prevailing rate of per diem wages are on file at the City and are available for inspection to any interested party on request. Copies of the prevailing rate of per diem wages also may be found at <http://www.dir.ca.gov/OPRL/DPreWageDetermination.htm>. Contractor and its subcontractors shall post a copy of the prevailing rate of per diem wages determination at each job site and shall make them available to any interested party upon request.

1.1.2. The wage rates determined by the DIR refer to expiration dates. If the published wage rate does not refer to a predetermined wage rate to be paid after the expiration date, then the published rate of wage shall be in effect for the life of this Contract. If the published wage rate refers to a predetermined wage rate to become effective upon expiration of the published wage rate and the predetermined wage rate is on file with the DIR, such predetermined wage rate shall become effective on the date following the expiration date and shall apply to this Contract in the same manner as if it had been published in said publication. If the predetermined wage rate refers to one or more additional expiration dates with additional predetermined wage rates, which expiration dates occur during the life of this Contract, each successive predetermined wage rate shall apply to this Contract on the date following the expiration date of the previous wage rate. If the last of such predetermined wage rates expires during the life of this Contract, such wage rate shall apply to the balance of the Contract.

1.2. **Penalties for Violations.** Contractor and its subcontractors shall comply with California Labor Code section 1775 in the event a worker is paid less than the prevailing wage rate for the work or craft in which the worker is employed. This shall be in addition to any other applicable penalties allowed under Labor Code sections 1720 - 1861.

- 1.3. Payroll Records.** Contractor and its subcontractors shall comply with California Labor Code section 1776, which generally requires keeping accurate payroll records, verifying and certifying payroll records, and making them available for inspection. Contractor shall require its subcontractors to also comply with section 1776. Contractor and its subcontractors shall submit weekly certified payroll records online via the City's web-based Labor Compliance Program. Contractor is responsible for ensuring its subcontractors submit certified payroll records to the City.
- 1.3.1.** Contractor and their subcontractors shall also furnish records specified in Labor Code section 1776 directly to the Labor Commissioner in the manner required by Labor Code section 1771.4.
-
- 1.4. Apprentices.** Contractor and its subcontractors shall comply with California Labor Code sections 1777.5, 1777.6 and 1777.7 concerning the employment and wages of apprentices. Contractor is held responsible for the compliance of their subcontractors with sections 1777.5, 1777.6 and 1777.7.
- 1.5. Working Hours.** Contractor and their subcontractors shall comply with California Labor Code sections 1810 through 1815, including but not limited to: (i) restrict working hours on public works contracts to eight hours a day and forty hours a week, unless all hours worked in excess of 8 hours per day are compensated at not less than 1½ times the basic rate of pay; and (ii) specify penalties to be imposed on contractors and subcontractors of \$25 per worker per day for each day the worker works more than 8 hours per day and 40 hours per week in violation of California Labor Code sections 1810 through 1815.
- 1.6. Required Provisions for Subcontracts.** Contractor shall include at a minimum a copy of the following provisions in any contract they enter into with a subcontractor: California Labor Code sections 1771, 1771.1, 1775, 1776, 1777.5, 1810, 1813, 1815, 1860 and 1861.
- 1.7. Labor Code Section 1861 Certification.** Contractor in accordance with California Labor Code section 3700 is required to secure the payment of compensation of its employees and by signing this Contract, Contractor certifies that "I am aware of the provisions of Section 3700 of the California Labor Code which require every employer to be insured against liability for workers' compensation or to undertake self-insurance in accordance with the provisions of that code, and I will comply with such provisions before commencing the performance of the work of this Contract."
- 1.8. Labor Compliance Program.** The City has its own Labor Compliance Program authorized in August 2011 by the DIR. The City will withhold contract payments when payroll records are delinquent or deemed inadequate by the City or other governmental entity, or it has been established after an investigation by the City or other governmental entity that underpayment(s) have occurred. For questions or assistance, please contact the City of San Diego's Equal Opportunity Contracting Department at 619-236-6000.

- 1.9. Contractor and Subcontractor Registration Requirements.** This project is subject to compliance monitoring and enforcement by the DIR. A contractor or subcontractor shall not be qualified to bid on, be listed in a bid or proposal, subject to the requirements of section 4104 of the Public Contract Code, or engage in the performance of any contract for public work, unless currently registered and qualified to perform public work pursuant to Labor Code section 1725.5. It is not a violation of this section for an unregistered contractor to submit a bid that is authorized by Section 7029.1 of the Business and Professions code or by Section 10164 or 20103.5 of the Public Contract Code, provided the contractor is registered to perform public work pursuant to Section 1725.5 at the time the contract is awarded.
- 1.9.1.** A Contractor's inadvertent error in listing a subcontractor who is not registered pursuant to Labor Code section 1725.5 in response to a solicitation shall not be grounds for filing a bid protest or grounds for considering the bid non-responsive provided that any of the following apply: (1) the subcontractor is registered prior to bid opening; (2) within twenty-four hours after the bid opening, the subcontractor is registered and has paid the penalty registration fee specified in Labor Code section 1725.5; or (3) the subcontractor is replaced by another registered subcontractor pursuant to Public Contract Code section 4107.
- 1.9.2.** By submitting a bid or proposal to the City, Contractor is certifying that he or she has verified that all subcontractors used on this public work project are registered with the DIR in compliance with Labor Code sections 1771.1 and 1725.5, and Contractor shall provide proof of registration for themselves and all listed subcontractors to the City at the time of bid or proposal due date or upon request.
- 1.10. Stop Order.** For Contractor or its subcontractors engaging in the performance of any public work contract without having been registered in violation of Labor Code sections 1725.5 or 1771.1, the Labor Commissioner shall issue and serve a stop order prohibiting the use of the unregistered contractors or unregistered subcontractor(s) on ALL public works until the unregistered contractor or unregistered subcontractor(s) is registered. Failure to observe a stop order is a misdemeanor.
- 1.11. List of all Subcontractors.** The City may ask Contractor for the most current list of subcontractors (regardless of tier), along with their DIR registration numbers, utilized on this Agreement at any time during performance of this contract, and Contractor shall provide the list within ten (10) working days of the City's request. Additionally, Contractor shall provide the City with a complete list of all subcontractors utilized on this contract (regardless of tier), within ten working days of the completion of the contract, along with their DIR registration numbers. The City shall withhold final payment to Contractor until at least 30 days after this information is provided to the City.

1.12. Exemptions for Small Projects. There are limited exemptions for Installation, alteration, demolition, or repair work done on projects of \$25,000 or less. The Contractor shall still comply with Labor Code sections 1720 et. seq. The only recognized exemptions are listed below:

1.12.1. Registration. The Contractor will not be required to register with the DIR for small projects. (Labor Code section 1771.1)

1.12.2. Certified Payroll Records. The records required in Labor Code section 1776 shall be required to be kept and submitted to the City of San Diego, but will not be required to be submitted online with the DIR directly. The Contractor will need to keep those records for at least three years following the completion of the Contract. (Labor Code section 1771.4).

1.12.3. List of all Subcontractors. The Contractor shall not be required to hire only registered subcontractors and is exempt from submitting the list of all subcontractors that is required in section 4.20.11 above. (Labor code section 1773.3).

ATTACHMENT E
SUPPLEMENTARY SPECIAL PROVISIONS

SUPPLEMENTARY SPECIAL PROVISIONS

The following Supplementary Special Provisions (SSP) modifies the following documents:

1. The **2015 Edition** of the Standard Specifications for Public Works Construction (The "GREENBOOK").
2. The **2015 Edition** of the City of San Diego Standard Specifications for Public Works Construction (The "WHITEBOOK"), including the following:
 - a) General Provisions (A) for all Contracts.

SECTION 1 - TERMS, DEFINITIONS, ABBREVIATIONS, UNITS OF MEASURE, AND SYMBOLS

- 1-2 TERMS AND DEFINITIONS.** To the "WHITEBOOK", item 54, "Normal Working Hours", ADD the following:

The **Normal Working Hours** are 8:00 AM to 4:00 PM Monday through Saturday.

SECTION 2 - SCOPE AND CONTROL OF WORK

- 2-3.2 Self Performance.** To the "GREENBOOK", DELETE in its entirety and SUBSTITUTE with the following:

You shall perform, with your own organization, Contract Work amounting to at least **30%** of the base Bid and **30%** of any alternates.

- 2-7 SUBSURFACE DATA.** To the "WHITEBOOK", ADD the following:

4. In preparation of the Contract Documents, the designer has relied upon the following reports of explorations and tests of subsurface conditions at the Work Site:

- a) Geotechnical Investigation, Torrey Pines Road Slope Reconstruction, Between Little Street and Roseland Drive, La Jolla, San Diego, California dated May 17, 2011 by Leighton and Associates, Inc.

5. The reports listed above are available for review by contacting the Contract Specialist or visiting:

<https://filecloud.sandiego.gov/url/e12hutc0drn5>

2-14.3 Coordination. To the "WHITEBOOK", ADD the following:

2. Other adjacent City projects are scheduled for construction for the same time period in the vicinity of La Jolla Shores Drive to Calle De La Plata. See **Appendix "F"** for the approximate location. Coordinate the Work with the adjacent projects as listed below:
 - a) Project Name: AC Water and Sewer Group 1011 (Water)
Project Manager: Ikhlass Shamoun at (619) 533-4619

2-15 TECHNICAL STUDIES AND DATA. To the "WHITEBOOK", ADD the following:

3. In preparation of the Contract Documents, the designer has relied upon the following reports of explorations and tests at the Work Site:
 - a) Results for Auger Testing for Torrey Pines Road Improvements, Phase II Project dated July 8, 2016 by LSA.
 - b) Memorandum: Torrey Pines Road Improvements Project Phase I: Project Modifications dated August 29, 2016 by Planning Department.
 - c) Biological Survey Letter Report Torrey Pines Slope Restoration dated September 19, 2012 by Merkel & Associates, Inc.

The reports listed above are available for review by contacting the Contract Specialist or visiting:

<https://filecloud.sandiego.gov/url/e12hutc0drn5>

2-16 CONTRACTOR REGISTRATION AND ELECTRONIC REPORTING SYSTEM. To the "WHITEBOOK", item 1, DELETE in its entirety.

SECTION 3 – CHANGES IN WORK

3-5.1 Claims. To the "WHITEBOOK", DELETE in its entirety and SUBSTITUTE with the following:

ADD:

3-5.1 Claims.

1. A Claim is a written demand by you that seeks an adjustment in the Contract Price, Contract Time, or other relief associated with a dispute arising under or

relating to the Contract, including a breach of any provision thereof. A voucher, invoice, or other routine request for payment is not a Claim.

2. A Claim shall conform to these specifications and may be considered after the City has previously denied a request by you for a Change Order seeking the demanded relief.
3. You shall submit a Claim to the Engineer if a dispute occurs that arises from or relates to the Contract. The Claim shall seek all relief to which you assert you are entitled as a result of the event(s) giving rise to the dispute. Your failure to process a Claim in accordance with these specifications shall constitute a waiver of all relief associated with the dispute. Claims are subject to 6-11, "Right to Audit".
4. You shall continue to perform the Services and Work and shall maintain the Schedule during any dispute proceedings. The Engineer will continue to make payments for undisputed Services and Work.
5. The City's Claims process specified herein shall not relieve you of your statutory obligations to present claims prior to any action under the California Government Code.

3-5.1.1 Initiation of Claim.

1. You shall promptly, but no later than 30 Days after the event(s) giving rise to the Claim, deliver the Claim to the Engineer.
2. You shall not process a Claim unless the Engineer has previously denied a request by you for a Change Order that sought the relief to be pursued in the claim.

3-5.1.1.1 Claim Certification Submittal.

1. If your Claim seeks an increase in the Contract Price, the Contract Time, or both, submit with the Claim an affidavit certifying the following:
 - a) The Claim is made in good faith and covers all costs and delays to which you are entitled as a result of the event(s) giving rise to the Claim.
 - b) The amount claimed accurately reflects the adjustments in the Contract Price, the Contract Time, or both to which you believe you are entitled.
 - c) All supporting costs and pricing data are current, accurate, and complete to the best of your knowledge. The cost breakdown per item of Work shall be supplied.
 - d) You shall ensure that the affidavit is executed by an official who has the authority to legally bind you.

3-5.1.2 Initial Determination.

1. The Engineer will respond in writing to your Claim within 30 Days of receipt of the Claim.

3-5.1.3 Settlement Meeting.

1. If you disagree with the Initial Determination, you shall request a Settlement Meeting within 30 Days. Upon receipt of this request, the Engineer will schedule the Settlement Meeting within 15 Working Days.

3-5.1.7 City's Final Determination.

1. If a settle agreement is not reached, the City shall make a written Final Determination within 10 Working Days after the Settlement Meeting.
2. If you disagree with the City's Final Determination, notify the Engineer in writing of your objection within 15 Working Days after receipt of the written determination and file a "Request for Mediation" in accordance with 3-5.2, "Dispute Resolution Process".
3. Failure to give notice of objection within the 15 Working Days period shall waive your right to pursue the Claim.

3-5.1.8 Mandatory Assistance.

1. If a third party dispute, litigation, or both arises out of or relates in any way to the Services provided under the Contract, upon the City's request, you shall agree to assist in resolving the dispute or litigation. Your assistance includes, but is not limited to the following:
 - a) Providing professional consultations.
 - b) Attending mediations, arbitrations, depositions, trials, or any event related to the dispute resolution and litigation.

3-5.1.8.1 Compensation for Mandatory Assistance.

1. The City will reimburse you for reasonable fees and expenses incurred by you for any required assistance rendered in accordance with 3-5.1.8, "Mandatory Assistance" as Extra Work.
2. The Engineer will determine whether these fees and expenses were necessary due to your conduct or failure to act.
3. If the Engineer determines that the basis of the dispute or litigation in which these fees and expenses were incurred were the result of your conduct or your failure to act in part or in whole, you shall reimburse the City for any payments made for these fees and expenses.
4. Reimbursement may be through any legal means necessary, including the City's withholding of your payment.

3-5.2.3 Selection of Mediator. To the "WHITEBOOK", DELETE in its entirety and SUBSTITUTE with the following:

1. A single mediator, knowledgeable in construction aspects and acceptable to both parties, shall be used to mediate the dispute.

2. To initiate mediation, the initiating party shall serve a Request for Mediation at the American Arbitration Association (AAA) on the opposing party.
3. If AAA is used, the initiating party shall concurrently file with AAA a "Request for Mediation" along with the appropriate fees, a copy of requested mediators marked in preference order, and a preference for available dates.
4. If AAA is selected to coordinate the mediation (Administrator), within 10 Working Days from the receipt of the initiating party's Request for Mediation, the opposing party shall file the following:
 - a) A copy of the list of the preferred mediators listed in preference order after striking any mediators to which they have any objection.
 - b) A preference for available dates.
 - c) Appropriate fees.
5. If the parties cannot agree on a mediator, then each party shall select a mediator and those mediators shall select the neutral third party to mediate the matter.

3-5.3 Forum of Litigation. To the "WHITEBOOK", DELETE in its entirety and SUBSTITUTE with the following:

1. It is the express intention that all legal actions and proceedings related to the Contract or Agreement with the City or to any rights or any relationship between the parties arising therefrom shall be solely and exclusively initiated and maintained in courts of the State of California for the County of San Diego.

SECTION 4 - CONTROL OF MATERIALS

4-1.3.2 Inspection by the Agency. To the "GREENBOOK", DELETE in its entirety and SUBSTITUTE with the following:

1. The City will provide inspection and testing laboratory services within the continental United States within a 200-mile radius of the geographical limits of the City.

4-1.3.3 Inspection of Items Not Locally Produced. To the "WHITEBOOK", DELETE in its entirety.

ADD:

4-1.3.3 Inspection of Items Not Locally Produced. To the "GREENBOOK", DELETE in its entirety and SUBSTITUTE with the following:

1. When you intend to purchase materials, fabricated products, or equipment from sources located more than 200 miles (321.9 km) outside the geographical limits of the City, City Lab staff or a qualified inspection agency approved by the Engineer, shall be engaged at your expense to inspect the materials, equipment, or process.

2. This approval shall be obtained before producing any material or equipment. City Lab staff or inspector shall evaluate the materials for conformance with the requirements of the Plans and Specifications. You shall forward reports required by the Engineer. No materials or equipment shall be shipped nor shall any processing, fabrication or treatment of such materials be done without proper inspection by City Lab staff or the approved agent. Approval by said agent shall not relieve you of responsibility for complying with the requirements of the Contract Documents.
3. The Engineer may elect City Lab staff to perform inspection of an out-of-town manufacturer. You shall incur additional inspection costs of the Engineer including lodging, meals, and incidental expenses based on Federal Per Diem Rates, along with travel and car rental expenses. If the manufacturing plant operates a double shift, a double shift shall be figured in the inspection costs.
 - a) At the option of the Engineer, full time inspection shall continue for the length of the manufacturing period. If the manufacturing period will exceed 3 consecutive weeks, you shall incur additional inspection expenses of the Engineer's supervisor for a trip of 2 Days to the site per month.
 - b) When the Engineer elects City Lab staff to perform out-of-town inspections, the wages of staff employed by the City shall not be part of the additional inspection expenses paid by you.
 - c) Federal Per Diem Rates can be determined at the location below:

<https://www.gsa.gov/portal/content/104877>

4-1.3.6 Preapproved Materials. To the "WHITEBOOK", ADD the following:

3. You shall submit in writing a list of all products to be incorporated in the Work that are on the AML.

4-1.6 Trade Names or Equals. To the "WHITEBOOK", ADD the following:

11. You shall submit your list of proposed substitutions for an "equal" item **no less than 15 Working Days prior to the Bid due date** and on the City's Product Submittal Form available at:

<http://www.sandiego.gov/publicworks/edocref/index.shtml>

SECTION 5 - UTILITIES

5-2 PROTECTION. To the "WHITEBOOK", item 2, ADD the following:

- g) Refer to Appendix "L" for more information on the protection of AMI devices.

5-6

COOPERATION. To the "GREENBOOK", ADD the following:

Notify Utility prior to excavating within 10 feet of utility facilities.

The construction schedule will need to account for utility relocation activities. You must coordinate with the utility companies for the relocations. Details regarding the utilities and type of work are described in detail in the table below for work shown on plan sheets 39770-01-D thru 39770-19-D.

Utility	Contact	Lead Time	Work Window	Stage of construction prior to Utility work	Type of Work to be conducted by Utilities
SDG&E ELECTRIC	Keenon C. Holmes Governmental Liaison Planner kholmes@semprautilities.com 858-654-8602 858-616-7999 (Cell)	8 weeks	4 weeks	Clear and grub for service point and metering pedestal; sidewalk subgrade for adjusting pull box to new grade, AC Overlay for adjustments of valves and covers to new grade on the street.	Relocate existing service point; set new metering pedestal; adjust pull box to new grade; adjust valves and covers to new grade
AT&T	Bob Richardson RR2681@att.com 858-268-2093 619-917-7480 (Cell)	8 weeks	2 weeks	Sidewalk subgrade	Adjust two (2) manhole lids to new grade
CHARTER COMMUNICATIONS	Raymond W. Harns Senior Project Coordinator Raymond.Harns@charter.com 858.635.8266	8 weeks	4 weeks	Clear and grub for relocation of conduit; sidewalk subgrade for adjusting communication pedestal(s)	Relocation of conduits to clear HAWK foundation and wall footing conflict and communication pedestal(s)/ Adjust to new grade

The construction schedule will need to account for utility relocation activities. You must coordinate with the utility companies for the relocations. Details regarding the utilities and type of work are described in detail in the table below for work shown on plan sheets 32132-1-D thru 32132-14-D.

Lead Time: Minimum number of working days written notice the Engineer provides the owner that the site will be ready for utility work.

Utility	Contact	Lead Time	Work Window	Stage of construction prior to Utility work	Type of Work to be conducted by Utilities
AT&T	George Tuttle gt3454@att.com 619-229-4042 619-200-2930(Cell) Or Kristine Escalle KD243X@att.com 951-452-3913	2 weeks	2 weeks	Clearing & Grubbing- Slope Grading	Adjust single direct buried cable

Work Window: Number of working days provided to the utility company to complete the listed utility work.

The Contractor shall coordinate with utilities for work described above and demobilize construction activity, equipment and material for the specific locations the utilities will conduct work for the specific days agreed upon with the utility companies.

SECTION 6 - PROSECUTION, PROGRESS AND ACCEPTANCE OF WORK

6-1.1 Construction Schedule. To the "WHITEBOOK", item 22, subsection b, DELETE in its entirety and SUBSTITUTE with the following:

- b) A curve value percentage comparison between the Contract Price and the updated cash flow forecast for each Project ID included in the Contract Documents. Curve values shall be set on a scale from 0% to 100% in intervals of 5% of the Contract Time. Refer to the Sample City Invoice materials in the Contract Documents and use the format shown. Your invoice amounts shall be supported by this curve value percentage. For previous periods, use the actual values and percentages and update the curve value percentages accordingly.

ADD the following:

- 23. Contractor to order HAWK signal poles and mast arms and notify the Franchise utility companies once LNTP is issued.

6-1.3 Work Outside Normal Working Hours. To the Whitebook, ADD the following:

- 4. The contractor shall be required to have at least one working crew for each project during construction between the hours of 8 am to 4 pm to complete the work in place within the contract time (Monday thru Saturday). The

contractor shall complete the construction prior to Memorial Day, May 28, 2018. The cost of working outside normal hours shall be included in the various bid items.

5. The City, at its discretion may direct the contractor to work different hours, if complaints have been aroused during construction. The changes in work schedule shall be at no additional cost to the City.

6-1.3.1 Payment. To the "WHITEBOOK", ADD the following:

3. The payment for any work outside normal working hours, including weekend work and night work, shall be done at no additional cost to the City.

ADD:

6-3.2.1.1 Environmental Documents.

1. The City of San Diego Environmental Analysis Section (EAS) of the Development Services Department has prepared a **Mitigated Negative Declaration and Consistency Evaluation Memo for Torrey Pines Road Improvements Phase 2**, DSD No. **316432**, as referenced in the Contract Appendix. You shall comply with all requirements of the **Mitigated Negative Declaration** as set forth in **Appendix A**.
2. The City of San Diego Environmental Analysis Section (EAS) of the Development Services Department has prepared a **Coastal Development Permit No. 846963, Site Development Permit NO. 846964, and Notice of Environmental Exemption (NOE) for Torrey Pines Road Slope Restoration**, as referenced in the Contract Appendix. You shall comply with all requirements of the **Coastal Development Permit, Site Development Permits, and NOE** as set forth in **Appendix A**.
3. Compliance with the City's environmental document shall be included in the Contract Price.

6-3.2.2 Archaeological and Native American Monitoring Program. To the "WHITEBOOK", ADD the following:

4. The City will retain a qualified archaeologist for this Contract. You shall coordinate your activities and Schedule with the activities and schedules of the archaeologist monitor. Notify the Engineer before noon of the Working Day before monitoring is required. See 2-11, "INSPECTION" for details.

6-8.3 Warranty. To the "WHITEBOOK", item 1, DELETE in its entirety and SUBSTITUTE with the following:

1. Warranty and repair all defective materials and workmanship for a period of 1 year. This call back warranty period shall start on the date that the Work was

accepted by the City. Additionally, you shall warranty the Work against all latent and patent defects for a period of 10 years.

SECTION 7 - RESPONSIBILITIES OF THE CONTRACTOR

7-3 INSURANCE. To the "GREENBOOK", DELETE in its entirety and SUBSTITUTE with the following:

7-3 INSURANCE.

1. The insurance provisions herein shall not be construed to limit your indemnity obligations contained in the Contract.

7-3.1 Policies and Procedures.

1. You shall procure the insurance described below, at its sole cost and expense, to provide coverage against claims for loss including injuries to persons or damage to property, which may arise out of or in connection with the performance of the Work by you, your agents, representatives, officers, employees or Subcontractors.
2. Insurance coverage for property damage resulting from your operations is on a replacement cost valuation. The market value will not be accepted.
3. You shall maintain this insurance for the duration of this Contract and at all times thereafter when you are correcting, removing, or replacing Work in accordance with this Contract. Your liabilities under the Contract, e.g., your indemnity obligations, is not deemed limited to the insurance coverage required by this Contract.
4. The payment for insurance shall be included in the Contract Price as bid by you. Except as specifically agreed to by the City in writing, you are not entitled to any additional payment. Do not begin any Work under this Contract until you have provided and the City has approved all required insurance.
5. Policies of insurance shall provide that the City is entitled to 30 Days (10 Days for cancellation due to non-payment of premium) prior written notice of cancellation or non-renewal of the policy. Maintenance of specified insurance coverage is a material element of the Contract. Your failure to maintain or renew coverage or to provide evidence of renewal during the term of the Contract may be treated by the City as a material breach of the Contract.

7-3.2 Types of Insurance.

7-3.2.1 Commercial General Liability Insurance.

1. Commercial General Liability Insurance shall be written on the current version of the ISO Occurrence form CG 00 01 07 98 or an equivalent form providing coverage at least as broad.
2. The policy shall cover liability arising from premises and operations, XCU (explosions, underground, and collapse), independent contractors, products/completed operations, personal injury and advertising injury, bodily injury, property damage, and liability assumed under an insured's contract (including the tort liability of another assumed in a business contract).
3. There shall be no endorsement or modification limiting the scope of coverage for either "insured vs. insured" claims or contractual liability. You shall maintain the same or equivalent insurance for at least 10 years following completion of the Work.
4. All costs of defense shall be outside the policy limits. Policy coverage shall be in liability limits of not less than the following:

<u>General Annual Aggregate Limit</u>	<u>Limits of Liability</u>
Other than Products/Completed Operations	\$2,000,000
Products/Completed Operations Aggregate Limit	\$2,000,000
Personal Injury Limit	\$1,000,000
Each Occurrence	\$1,000,000

7-3.2.2 Commercial Automobile Liability Insurance.

1. You shall provide a policy or policies of Commercial Automobile Liability Insurance written on the current version of the ISO form CA 00 01 12 90 or later version or equivalent form providing coverage at least as broad in the amount of \$1,000,000 combined single limit per accident, covering bodily injury and property damage for owned, non-owned, and hired automobiles ("Any Auto").
2. All costs of defense shall be outside the limits of the policy.

7-3.3 Rating Requirements. Except for the State Compensation Insurance Fund, all insurance required by this Contract as described herein shall be carried only by responsible insurance companies with a rating of, or equivalent to, at least "A-, VI" by A.M. Best Company, that are authorized by the California Insurance Commissioner to do business in the State, and that have been approved by the City.

7-3.3.1 Non-Admitted Carriers. The City will accept insurance provided by non-admitted, "surplus lines" carriers only if the carrier is authorized to do business in the State and is included on the List of Approved Surplus Lines Insurers (LASLI list).

All policies of insurance carried by non-admitted carriers shall be subject to all of the requirements for policies of insurance provided by admitted carriers described herein.

7-3.4 Evidence of Insurance. Furnish to the City documents e.g., certificates of insurance and endorsements evidencing the insurance required herein, and furnish renewal documentation prior to expiration of this insurance. Each required document shall be signed by the insurer or a person authorized by the insurer to bind coverage on its behalf. We reserve the right to require complete, certified copies of all insurance policies required herein.

7-3.5 Policy Endorsements.

7-3.5.1 Commercial General Liability Insurance.

7-3.5.1.1 Additional Insured.

1. You shall provide at your expense policy endorsement written on the current version of the ISO Occurrence form CG 20 10 11 85 or an equivalent form providing coverage at least as broad.
2. To the fullest extent allowed by law e.g., California Insurance Code §11580.04, the policy shall be endorsed to include the City and its respective elected officials, officers, employees, agents, and representatives as additional insured.
3. The additional insured coverage for projects for which the Engineer's Estimate is \$1,000,000 or more shall include liability arising out of:
 - a) Ongoing operations performed by you or on your behalf,
 - b) your products,
 - c) your Work, e.g., your completed operations performed by you or on your behalf, or
 - d) premises owned, leased, controlled, or used by you.
4. The additional insured coverage for projects for which the Engineer's Estimate is less than \$1,000,000 shall include liability arising out of:
 - a) Ongoing operations performed by you or on your behalf,
 - b) your products, or
 - c) premises owned, leased, controlled, or used by you.

7-3.5.1.2 Primary and Non-Contributory Coverage. The policy shall be endorsed to provide that the coverage with respect to operations, including the completed operations, if appropriate, of the Named Insured is primary to any insurance or self-insurance of the

City and its elected officials, officers, employees, agents and representatives. Further, it shall provide that any insurance maintained by the City and its elected officials, officers, employees, agents and representatives shall be in excess of your insurance and shall not contribute to it.

7-3.5.1.3 Project General Aggregate Limit. The policy or policies shall be endorsed to provide a Designated Construction Project General Aggregate Limit that will apply only to the Work. Only claims payments which arise from the Work shall reduce the Designated Construction Project General Aggregate Limit. The Designated Construction Project General Aggregate Limit shall be in addition to the aggregate limit provided for the products-completed operations hazard.

7-3.5.2 Commercial Automobile Liability Insurance.

7-3.5.2.1 Additional Insured. Unless the policy or policies of Commercial Auto Liability Insurance are written on an ISO form CA 00 01 12 90 or a later version of this form or equivalent form providing coverage at least as broad, the policy shall be endorsed to include the City and its respective elected officials, officers, employees, agents, and representatives as additional insured, with respect to liability arising out of automobiles owned, leased, hired or borrowed by you or on your behalf. This endorsement is limited to the obligations permitted by California Insurance Code §11580.04.

7-3.6 Deductibles and Self-Insured Retentions. You shall pay for all deductibles and self-insured retentions. You shall disclose deductibles and self-insured retentions to the City at the time the evidence of insurance is provided.

7-3.7 Reservation of Rights. The City reserves the right, from time to time, to review your insurance coverage, limits, deductibles and self-insured retentions to determine if they are acceptable to the City. The City will reimburse you, without overhead, profit, or any other markup, for the cost of additional premium for any coverage requested by the Engineer but not required by this Contract.

7-3.8 Notice of Changes to Insurance. You shall notify the City 30 Days prior to any material change to the policies of insurance provided under this Contract.

7-3.9 Excess Insurance. Policies providing excess coverage shall follow the form of the primary policy or policies e.g., all endorsements.

7-4 **NOT USED.** To the "GREENBOOK", DELETE in its entirety and SUBSTITUTE with the following:

7-4 **WORKERS' COMPENSATION INSURANCE AND EMPLOYERS LIABILITY INSURANCE.**

1. In accordance with the provisions of §3700 of the California Labor Code, you shall provide at your expense Workers' Compensation Insurance and Employers Liability Insurance to protect you against all claims under applicable state workers compensation laws. The City, its elected officials, and employees will not be responsible for any claims in law or equity occasioned by your failure to comply with the requirements of this section.
2. Limits for this insurance shall be not less than the following:

<u>Workers' Compensation</u>	<u>Statutory Employers Liability</u>
Bodily Injury by Accident	\$1,000,000 each accident
Bodily Injury by Disease	\$1,000,000 each employee
Bodily Injury by Disease	\$1,000,000 policy limit

3. By signing and returning the Contract you certify that you are aware of the provisions of §3700 of the Labor Code which requires every employer to be insured against liability for worker's compensation or to undertake self-insurance in accordance with the provisions of that code and you shall comply with such provisions before commencing the Work as required by §1861 of the California Labor Code.

7-4.1. Waiver of Subrogation. The policy or policies shall be endorsed to provide that the insurer will waive all rights of subrogation against the City and its respective elected officials, officers, employees, agents, and representatives for losses paid under the terms of the policy or policies and which arise from Work performed by the Named Insured for the City.

7-5 **PERMITS, FEES, AND NOTICES.** To the "WHITEBOOK", ADD the following:

2. The City will obtain, at no cost to you, the following permits:
 1. COASTAL DEVELOPMENT PERMIT NO. 846963
 2. SITE DEVELOPMENT PERMIT NO. 846964

7-8.6 **Water Pollution Control.** To the "WHITEBOOK", ADD the following:

6. Based on a preliminary assessment by the City, this Contract is subject to **WPCP.**

7-8.6.5.1 Payment. To the "WHITEBOOK", DELETE in its entirety.

ADD:

7-8.6.5.1 Chlorination Discharge Requirements.

1. If prior approval is obtained to discharge to the sewer system, you shall discharge the chlorinated water used for testing and acceptance of new water mains to the sewer system in accordance with the Contract Documents after de-chlorination as shown on the "Chlorination Discharge Locations" Plans. You shall submit to the Engineer a "Request for Batch Discharge Authorization to Discharge Potable Pipe Flushing Water to Sewer" form. The request form is found on the City website at the following location:

https://www.sandiego.gov/sites/default/files/batch_discharge_authorization_request_1.pdf

2. When discharging to the sewer system has been approved, you shall use a totalizer flow meter to record the total volume discharged to sewer and shall submit to the Engineer a log of actual discharged water quantities, dates, and locations. Failure to report this information to the Engineer is a violation of the authorization for discharge to the sanitary sewer. Within five (5) Working Days of the discharge, the Engineer shall report actual total flows to the sanitary sewer to the Public Utilities Department (PUD), Industrial Wastewater Control Program (IWCP).
3. If the discharge to the sewer system is not approved, you shall discharge the chlorinated water used for the testing of new mains to surface waters, storm drain inlets, or to other approved sources and you shall comply with 7-8.6.5, "Hydrostatic Discharge Requirements". All discharge activities related to the project shall comply with the State Water Resources Control Board, ORDER WQ 2014-0194-DWQ, STATEWIDE GENERAL NPDES PERMIT FOR DRINKING WATER SYSTEMS DISCHARGES as referenced by:

http://www.waterboards.ca.gov/water_issues/programs/npdes/docs/drinking_water/final_statewide_wqo2014_0194_dwq.pdf

All testing shall be conducted by a QSP.

ADD:

7-8.6.5.2 Payment.

1. The payment for complying with the discharge requirements shall be included in the Bid item for the new water main.

7-20 ELECTRONIC COMMUNICATION. To the "WHITEBOOK", ADD the following:

2. Virtual Project Manager shall be used on this Contract.

7-21.1 General. To the "WHITEBOOK", item 3, DELETE in its entirety and SUBSTITUTE with the following:

3. During the construction phase of projects, the minimum waste management reduction goal is 90% of the inert material (a material not subject to decomposition such as concrete, asphalt, brick, rock, block, dirt, metal, glass, and etc.) and 65% of the remaining project waste. You shall provide appropriate documentation, including a Waste Management Form attached as an appendix, and evidence of recycling and reuse of materials to meet the waste reduction goals specified.

7-21.9 Payment. To the "WHITEBOOK", DELETE in its entirety and SUBSTITUTE with the following:

The lump sum Bid price paid for "Site Storage and Handling of Construction and Demolition Waste" shall include full compensation for site storage and handling of construction and demolition waste in accordance with Plans on sheets **32132-1-D thru 32132-14-D**, Standard Specifications and these Special Provisions, and as directed by the Engineer.

SECTION 9 - MEASUREMENT AND PAYMENT

ADD:

9-3.7 Compensation Adjustments for Price Index Fluctuations. To the "WHITEBOOK", ADD the following:

5. This Contract **is not** subject to the provisions of The "WHITEBOOK" for Compensation Adjustments for Price Index Fluctuations for paving asphalt.

SECTION 205 - PILES

ADD:

205-4 Soil Nails.

- A. See materials listed on the plans for complete assembly of soil nail anchors, 4-inch Temporary Shotcrete Fascia with reinforcement, 10-inch Permanent Shotcrete wall face with reinforcement, final Boulder/Rock scaping face veneer and weep holes.

- B. Geocomposite Drain: Vertical, high-performance, high-strength drainage composite consisting of a three-dimensional high-impact polystyrene core, and a nonwoven filter fabric, in 24' wide rolls. Miradrain 6000XL or approved equal.

SECTION 209 – PRESSURE PIPE

209 PRESSURE PIPE. To the “WHITEBOOK”, ADD the following:

2. PVC products, specifically type C900 and C905, as manufactured or distributed by J-M Manufacturing Company or JM Eagle shall not be used on the Contract for pressurized pipe.

SECTION 217 – BEDDING AND BACKFILL MATERIALS

217-2.2 Stones, Boulders, and Broken Concrete. To Table 217-2.2, DELETE in its entirety and SUBSTITUTE with the following:

TABLE 217-2.2

Zone	Zone Limits	Maximum Size (greatest dimension)	Backfill Requirements in Addition to 217-2.1
Street or Surface Zone		2.5" (63 mm)	As required by the Plans or Special Provisions.
Street or Surface Zone Backfill of Tunnels beneath Concrete Flatwork	From ground surface to 12" (300 mm) below pavement subgrade or ground surface	Sand	Sand equivalent of not less than 30.
Trench Zone	From 12" (300 mm) below pavement subgrade or ground surface to 12" (300 mm) above top of pipe or box	6" (150 mm)	
Deep Trench Zone (Trenches 3' (0.9 m) wide or wider)	From 60" (1.5 m) below finished surface to 12" (300 mm) above top of pipe or box	Rocks up to 12" (300 mm) excavated from trench may be placed as backfill	
Pipe Zone	From 12" (300 mm) above top of pipe or box to 6" (150 mm) below bottom of pipe or box exterior	2.5" (63 mm)	Sand equivalent of not less than 30 or a coefficient of permeability greater than 1-½ inches/hour (35 mm per hour).

Zone	Zone Limits	Maximum Size (greatest dimension)	Backfill Requirements in Addition to 217-2.1
Overexcavation	Backfill more than 6" (150 mm) below bottom of pipe or box exterior	6" (150 mm)	Sand equivalent of not less than 30 or a coefficient of permeability greater than 1-½ inches/hour (35 mm per hour). Trench backfill slurry (100-E-100) per 201-1 may also be used.

SECTION 300 - EARTHWORK

300-1.1 General. To the "WHITEBOOK", ADD the following:

10. Prior to submittal of a Bid for this Work, the Contractor shall inspect the project site to verify the magnitude and cost of all clearing and grubbing required to accomplish the Work per sheets **39770-01-D thru 39770-19-D**.

300-1.3.2 Requirements. To the "WHITEBOOK", ADD the following:

6. **GUNITE DEMOLITION.** As part of the clearing and grubbing activities, the existing gunite wall material shall be demolished and removed.

300-1.4 Payment. To the "WHITEBOOK", item 2, DELETE in its entirety and SUBSTITUTE with the following:

- a. The lump sum Bid price paid for "Clearing and Grubbing" shall include full compensation for the sawcutting, demolition, removal, protection, and disposal of any and all existing improvements up to proposed subgrade: including, but not limited to, soil, pavement (Asphalt Concrete, PCC, Base, Unclassified Materials), sidewalk, AC median and median curb, curb and gutter, driveways, curb ramps, curb inlets, storm drain pipe, sound wall footing if necessary, landscaping, private irrigation, private property lights, private address sign and mailbox, abandoned utilities, bollards, and utility structures (pull boxes, conduit, wiring, etc.), signs and sign posts, vegetation, shrubs, trees, and any other materials and objects that are in conflict with the installation of the new improvements per the plans and specifications.

SECTION 301 - TREATED SOIL, SUBGRADE PREPARATION, AND PLACEMENT OF BASE MATERIALS

301-1.7 Payment. To the "WHITEBOOK", ADD the following:

7. The payment for adjusting existing storm drain cleanout frame and cover to grade shall be included in the Bid item for "Adjust Existing Storm Drain Cleanout Frame And Cover To Grade (Behind the Curb)".

8. The payment for adjusting existing water meter to grade shall be included in the Bid Item for "Adjust Existing Water Meter to Grade".
9. The payment for adjusting existing water gate valve frame and cover to grade shall be included in the Bid Item for "Adjust Existing Water Gate Valve Frame and Cover to Grade (Behind the Curb)".
10. The payment for adjusting existing sewer manhole frame and cover to grade shall be included in the Bid item for "Adjust Existing Sewer Manhole Frame and Cover To Grade (Behind the Curb)".
11. The payment for adjusting existing electrical box to grade shall be included in the Bid Item for "Adjust Existing Electrical Box to Grade".
12. The payment for adjusting existing communication cabinet to grade shall be included in the Bid Item for "Adjust Existing Communication Cabinet to Grade".

SECTION 302 - ROADWAY SURFACING

302-1.1 General. To the WHITEBOOK, ADD the following:

In areas where colored stamped asphalt concrete is to be installed on an existing roadbed, the areas shall be cold milled to a minimum depth of two (2") inches per the Plans on sheets **39770-01-D thru 39770-19-D** and Specifications.

302-1.12 Payment. To the WHITEBOOK, ADD the following:

5. Payment for cold milling shall be included in the square foot Bid item for "Cold Mill AC Pavement (2 inch)".

302-5.9 Measurement and Payment. To the "WHITEBOOK", item 2, DELETE in its entirety

ADD:

302-5.9.1 Payment For Asphalt Concrete (For existing median removal)

The lump sum Bid price paid for "Asphalt Concrete (For Existing Median Removal)" used for replacement of removed raised median shall include full compensation for full depth schedule J asphalt brought up to the grade of existing street shown on sheet **39770-09-D**.

302-5.9.2 Payment for Asphalt Concrete Overlay (2 inch) including Loop Detector Replacements

The contract price paid for per ton for "Asphalt Concrete Overlay (2 inch) including Loop Detector Replacements", shall include full compensation for furnishing all labor, materials, tools, equipment and incidentals, and for doing all the work involved in

completing the Asphalt Concrete Overlay, replacement of the signal loop detectors, and the adjustment of the utility manholes, covers, and lids in the street as necessary to match the finish grade. Contractor is responsible for verifying the utilities within the street which may require adjustment of manholes, covers, and lids to finish grade prior to bid submittal.

ADD:

302-5.11 Colored Stamped Asphalt Concrete

302-5.11.1 General. Colored stamped asphalt concrete (AC) shall be at locations specified on the Plans and as directed by the Resident Engineer. Installation shall be in conformance with the Plans on sheets **39770-01-D thru 39770-19-D**, Specifications, manufacturer's specifications, and as directed by the Resident Engineer.

302-5.11.2 Submittals. The Contractor shall turn in submittals of stamped asphalt concrete pattern and color, and any other requested materials, to Resident Engineer per 2-5.3, "Submittals".

302-5.11.3 Test Plot. A test plot of ten (10') feet x ten (10') feet minimum shall be successfully completed at a location approved by the Resident Engineer before beginning work on colored stamped asphalt concrete. The test plot shall demonstrate the stamped pattern, texture, color coating and sealer/hardener, and shall be inspected by the Resident Engineer. The panel shall be corrected and re-built until written approval from the Resident Engineer is obtained. Payment for production of test plots, including corrections, shall be included in the bid item titled "Colored Stamped Asphalt Concrete".

Colored stamped asphalt concrete shall not be placed on the project prior to approval by the Resident Engineer of the test plot and the exact location and limits of installation.

When no longer required, the colored stamped asphalt concrete test plot shall become the property of the Contractor and shall be removed and disposed of in conformance with the Plans on sheets **39770-01-D thru 39770-19-D** and Specifications.

302-5.11.4 Asphalt Concrete. In areas that are cold mill, asphalt concrete shall be spread in accordance with the Plans per sheets **39770-01-D thru 39770-19-D** and Specifications. Spreading shall be performed by methods that will produce an asphalt concrete surfacing of uniform smoothness, texture, and density. Asphalt concrete shall be placed in one layer to a compacted thickness of two (2") inches. Asphalt concrete shall be thoroughly compacted by the use of power rollers. When power rollers cannot be operated in certain areas due to the shape or size of the areas, compaction shall be obtained by hand rollers, impactors, or other methods approved

by the Engineer. Where asphalt is not to be applied adjacent to pavement, curbs, dikes, or bulkheads, the free edge of the asphalt should be tamped at a neat forty-five (45) degree angle during placement. The free edge shall be neat, and to follow predefined lines.

302-5.11.5 Asphalt Concrete Stamp Pattern. Immediately after compaction of asphalt, the pattern shall be applied while the asphalt is still in a warm to hot pliable state. Consistent patterning shall be achieved using steel rollers and/or vibratory plate compactors to achieve the desired pattern and depth. The templates shall be removed after the desired pattern and depth is achieved. Double printing caused by template misalignment or due to movement during printing is not acceptable, and shall be repaired prior to coating. Gaps in grout lines that butt between two templates or between printed areas and non-printed areas will not be accepted, and shall be repaired prior to coating.

302-5.11.6 Asphalt Concrete Color Coating.

1. For the colored stamped asphalt concrete the asphalt color coating shall be an integrally colored, polymer modified, cementitious coating. The color shall be a red, "brick" color, and Herringbone pattern or approved equal, and shall be approved by the Resident Engineer prior to application.
2. Asphalt concrete shall be colored and sealed in a 2-step process in the following sequence:
 - a. Colored surface coating shall be evenly applied to the asphalt concrete when it has cooled sufficiently per manufacturer's application instructions. The coating shall be an integrally colored, polymer modified cementitious coating and shall be applied a minimum of 0.02 inches thick. The color coat shall be applied when the air temperature is above 44.6 °F and precipitation is not expected within 24 hours.
 - b. Color coat hardener shall be diluted per manufacturer's recommendations and evenly applied by a spray method after the color coat surface has dried. After spray application, the surface may be lightly broomed to ensure an even application. A second coat of hardener shall be applied after the first has dried.
3. Minimally, the surface coating must be 100% dry before traffic is permitted. Refer to the asphalt pavement coating supplier's guide.

302-5.11.7 Measurement. Colored stamped asphalt concrete will be measured by the square foot in place.

302-5.11.8 Payment. The contract price paid per square foot for "Colored Stamped Asphalt Concrete" shall include full compensation for furnishing all labor, materials, tools, equipment, and incidentals, and for doing all the work involved in production of test

plots, stamping of asphalt pattern, and coloring of stamped asphalt, complete in place, as designated on the Plans on sheets **39770-01-D thru 39770-19-D**, as specified in the Specifications and the manufacturer's specifications, and as directed by the Resident Engineer for Bid item "Colored Stamped Asphalt Concrete".

302-7.4 Payment. To the "WHITEBOOK", item 1, last sentence, DELETE in its entirety and SUBSTITUTE with the following:

Payment shall not be made for additional fabric for overlapped areas.

SECTION 303 - CONCRETE AND MASONRY CONSTRUCTION

303-1.11 Payment. To the "GREENBOOK", ADD the following:

The lineal foot contract price for "Gravity Retaining Wall Type A" shall include full compensation for furnishing all labor, materials, equipment and incidentals, excavation, backfill, PCC behind the wall, and two (2) coats of anti-graffiti coating in accordance with manufacturers recommendations and Whitebook Section 210-1.1.1, the coating shall have a manufacturer warranty of five years, and all other work necessary to complete in place, as shown on plans on sheets **39770-01-D thru 39770-19-D** and Specifications and as directed by the Engineer.

303-4.1.5 Measurement and Payment. To the "GREENBOOK", ADD the following:

The square foot contract price for "Masonry Retaining Wall" shall be measured from the top of the foundation footing to top of the wall, and shall include full compensation for furnishing all labor, materials, tools, equipment and incidentals, minor grading, gravel, foundation footing, excavation and select pervious backfill behind the wall, backfill, tan color masonry blocks, including concrete, grout, mortar, reinforcement, footings, filter fabric, waterproofing, weep holes, gravel drains, 3" perforated PVC drain pipes, apply 2 coats of anti-graffiti coating in accordance with manufactures recommendations, the coating shall have a manufacturer warranty of five years as shown on sheets **39770-01-D thru 39770-19-D** and Specifications and as directed by the Engineer.

303-5.1.1 General. To the "WHITEBOOK", ADD the following:

7. The monolithic curb shall be installed per the size as indicated in the plans on sheets **39770-01-D thru 39770-19-D**.

303-5.9 Measurement and Payment. To the "WHITEBOOK", ADD the following:

7. The payment for installing monolithic curb shall be included in the Bid Item "Concrete Monolithic Curb" and shall include full compensation for furnishing all

labor, materials, tools, equipment and incidentals and PCC behind the Concrete Monolithic Curb and shall be calculated as linear feet.

8. The payment for the installation of new sidewalk shall be included in the Bid Item "Sidewalk" and shall be calculated as square feet.

SECTION 304 -METAL FABRICATION AND CONSTRUCTION

304-5 **PAYMENT.** To the "WHITEBOOK", REVISE section "304-5" to "304-6".

SECTION 305 - PILE DRIVING AND TIMBER CONSTRUCTION

ADD:

305-3 **SOIL NAIL WALL WITH VENEER (BOULDER/ROCK SCAPING)**

305-3.1 **General.** This work consists of:

- A. Constructing soil nail retaining walls, including complete assembly of soil nail anchors, 4-inch Temporary Shotcrete Fascia with reinforcement, 10-inch Permanent Shotcrete wall face with reinforcement, final Boulder/Rock scaping face veneer, wall drainage, and weep holes.
- B. Surveying and verifying the limits of the wall installation.

305-3.1.1 **Requirement.** The City recommends the Contractor or subcontractor demonstrate satisfactory and successful completion of at least 3 permanent soil nail-retaining wall projects during the past 5 years, to total at least 8,000 square feet of wall face area and at least 500 permanent soil nails in California.

305-3.1.2 **Contractor Submittals.**

1. Submittals shall be made in accordance with 2-5.3, "Submittals".
2. At least 30 calendar days before starting soil nail retaining wall work, submit the following:
 - a. Start date and proposed retaining wall construction sequence. Include the proposed method of excavating to ensure wall and slope stability.
 - b. Drilling methods and equipment. Include drill hole diameter to achieve the specified pullout resistance values and any variation of drill hole diameter or specific pullout resistance along the wall alignment.
 - c. Nail grout mix design, placement procedures, and equipment. Include test results conducted according to AASHTO T 106 and supplied by a qualified testing lab verifying grout 3-day and 28-day compressive

strengths. Previous test results for the same grout mix completed within one year of grouting are acceptable.

- d. Soils nail testing methods and equipment setup.
- e. Identification number and calibration test results for each test jack, pressure gauge, and load cell. Calibrate the test jack and pressure gauge as one unit. Submit results from calibration tests conducted by an independent testing laboratory within the previous 90 days.
- f. Ultimate strength of proposed soil nail tendons.

305-3.2 Onsite Materials.

- 1. All materials shall be accurately measured by weight or volume for mixing. If a variable proportioning pump system is used, positive controls shall be incorporated to ensure accurate proportioning. Care shall be taken not to contaminate mixing vessels with reactive chemical by spillage, splash, etc.
- 2. A fast check reaction shall be made with each new primary chemical batch. A test sample shall be made of every injection batch. The Contractor shall keep records to establish the point of injection for each sample. This data shall be submitted to the Engineer on a daily basis.
- 3. If any sample fails to show the proper gelation, the potential area of failure shall be re-injected. The Contractor shall propose method of correction. Receive approval of Engineer prior to commencing correction.

305-3.3 Execution. Complete any clearing and excavation above the wall area before commencing wall excavation. Do not perform any of the wall excavation before beginning the wall construction. A work bench for the drilling equipment may be provided by placing material excavated from elsewhere on the project in front of the soil nail wall area.

Perform excavation for the wall in lifts concurrent with soil nail installation and shotcrete placement. Do not allow the exposed unsupported final excavation face cut height to exceed the vertical nail spacing plus the required reinforcing lap or the short-term stand-up height of the ground, whichever is less. Complete excavation to the final wall excavation line and application of the shotcrete in the same work shift. Application of the shotcrete may be delayed up to 24 hours if it can be demonstrated the delay will not adversely affect the excavation face stability. A stabilizing berm of soil may be left in place to contain the lift face during nail installation.

Do not excavate to the next lower lift until nail installation, reinforced shotcrete placement, attachment of bearing plates and nuts, and nail testing have been completed and accepted in the current lift. Cure grout and shotcrete at least 72 hours or attain the specified 3-day compressive strength before excavating the next underlying lift.

305-3.3.1 Nail Installation

1. **STORING AND HANDLING.** Store and handle soil nail tendons in a manner that avoids damage or corrosion. Replace tendons exhibiting abrasions, cuts, weld splatter, corrosion, or pitting. Repair or replace any tendons exhibiting damage to the encapsulation or epoxy coating.
2. **FABRICATION.** Provide tendons threaded sized as specified on the plans. Threading may be continuous spiral deformed ribbing provided by the bar deformations or may be cut into the reinforcing bar.

Use the next larger bar size if threads are cut into the reinforcing bar. When appropriate, repair damage to the epoxy coating with a minimum 16 mil-thick coating.

Provide centralizers sized to position the tendon within 1 inch of the center of the drill hole. Position centralizers a maximum of 10 feet apart and within 24 inches from the top and bottom of the tendon. Use centralizers that do not impede the free flow of grout into the drill hole.

3. **DRILLING.** Drill holes for the soil nails at the locations and to the orientation shown on the plans. Select drilling equipment and methods suitable for the ground conditions. Do not use water, drilling mud or other fluids for drilling or removing cuttings. If unstable ground is encountered, use cased drilling methods to support the circumference of the drill holes. Self-drilling tendon are not acceptable.
4. **GROUTING.** Insert the nail tendon into the hole and grout the drill hole within 2 hours of completing drilling. Inject the grout at the lowest point of each drill hole through a grout tube, casing, hollow-stem auger, or drill rods. Completely fill the drill hole in one continuous operation. To prevent voids, keep the outlet end of the grout conduit below the surface of the grout as the conduit is withdrawn. Cold joints in the grout column are only allowed at the top of the test bond length of proof-tested production nails.

Maintain the temporary unbonded length of proof test nails open for subsequent grouting. If the unbonded test length of production proof test nails cannot be satisfactorily grouted subsequent to testing, install a new nail in its place.

305-3.3.2 Nail Testing. Perform both verification and proof testing of designated test nails. Do not test any nail until the nail grout and shotcrete facing have cured for at least 72 hours and attained the specified 3-day compressive strength.

1. **TESTING EQUIPMENT.** Furnish two dial gauges, dial gauge support, jack and pressure gauge, electronic load cell, and a reaction frame. The load cell is required for verification tests only.

Use pressure gauges graduated in no greater than 100-pound per square inch increments. Measure the nail head movement with a minimum of two dial gauges capable of measuring to 0.001 inch.

2. VERIFICATION TESTING OF PRODUCTION NAILS. Perform verification tests on sacrificial test nails at locations in field as directed by the Engineer. Perform verification tests before installation of production nails to verify drilling and installation methods, nail pullout resistance, and design assumptions.

Provide verification test nails with both bonded and unbonded lengths. The minimum unbonded length is 3 feet and the minimum bonded length is 10 feet. Determine the maximum bonded length based on the verification nail bar grade and size to avoid exceeding the allowable bar structural load during testing. Provide larger bar sizes if required to safely accommodate the 10-foot minimum test bond length and testing to twice the allowable pullout resistance.

3. PROOF TESTING OF PRODUCTION NAILS. Perform proof tests on production nails at locations selected by the City Inspector. Perform successful proof testing on 5 percent of the production nails in each nail row or a minimum of 1 per row. Provide production proof test nails with both bonded and temporary unbonded lengths.

The minimum temporary unbonded length is 3 feet. Determine the maximum bonded length based on the production nail bar grade and size to avoid exceeding the allowable bar structural load during testing. Provide a test nail bonded length of 10 feet or LBPmax, whichever is less.

Perform proof tests by incrementally loading the proof test nail to 150 percent of the design load as indicated in Table 305-3.3.2 below. Measure and record soil nail movement at each load increment.

Table 305-3.3.2 Proof Test Load Schedule

Test Load Increment	Hold Time (minutes)
AL (0.05DTL max.)	Until stable
0.25DTL	Until stable
0.50DTL	Until stable
0.75DTL	Until stable
1.00DTL	Until stable
1.25DTL	Until stable
1.50DTL (maximum load)	See below

Note: AL = Alignment load; DTL = Design test load.

The alignment load should be the minimum load required to align the testing apparatus and should not exceed 5 percent of the design test load. Set dial gauges to "zero" after the alignment load has been applied.

Perform either 10-minute or 60-minute creep tests at the maximum load. Start the creep period after the maximum test load is applied. Measure and record nail movement at 1, 2, 3, 5, 6, and 10 minutes. When the nail movement between 1 minute and 10 minutes exceeds 0.04 inches, maintain the maximum test load an additional 50 minutes, recording movement at 20, 30, 50, and 60 minutes. Maintain all load increments within 5 percent of the intended load.

4. PERFORMANCE TESTING OF PRODUCTION NAILS. Performance Test 2 anchors minimum in each different rock/soil material @ 150% of allowable pull-out resistance in accordance with FHWA "Geotechnical Engineering Circular No.4."

305-3.3.3 Wall Drainage Network. Install all elements of the drainage network, as appropriate, before shotcreting each lift.

Install geocomposite sheet drain strips centered between nail columns with the geotextile side against the ground. Add additional drain strips at locations where seepage is obvious. Secure strips to the excavated face to prevent shotcrete from contaminating the ground side of the geotextile. Construct drain strip splices with a 12-inch overlap so that the drain is vertically continuous and the splice does not impede the flow of water. Place PVC pipe sections, as shown on Plans.

305-3.3.4 Wall Construction. Place steel welded wire mesh and reinforcing steel as shown on the plans. Construct shotcrete facing. Completely fill the top ungrouted zone of any nail drill holes or other voids with shotcrete.

Attach a bearing plate and nut to each nail head. While the shotcrete is still plastic, uniformly seat the plate by tightening the nut with a hand wrench. Where uniform contact between the plate and the shotcrete cannot be provided, set the plate in a bed of grout and tighten the nut with a hand wrench after the grout has set for 24 hours.

Construction tolerances for wall elements are shown in Table 305-3.3.4.

Table 305-3.3.4 Wall Element Construction Tolerances

Wall Element	Tolerance
Horizontal location of headed studs, from plan location	3/8 inch
Location of headed studs on bearing plate, from plan location	1/4 inch
Nail head bearing plate, deviation from parallel to wall face	10 degrees

305-3.3.5 Permanent Wall Facing. Construct the permanent wall facing according to the applicable Subsection below. When applicable, finish surfaces with sculpted rock finish.

Construct shotcrete facing. Construction tolerances for the permanent shotcrete facing are shown in Table 305-3.3.3.

Table 305-3.3.3 Permanent Shotcrete Facing Construction Tolerances

Facing Finish	Tolerance
Complete thickness of shotcrete, from plan dimension: Troweled or screeded finish Shot finish	5/8 inch 1-1/8 inches
Planeness of finish face, surface gap under a 10-foot straightedge: Troweled or screeded finish Shot finish	5/8 inch 1-1/8 inches

305-3.4 Sculpted Rock Finish Facing. All textured rock shall be finished to produce a rock-like aesthetic finish to simulate the color and texture of the approved on site mock-up. Producing a rock-like aesthetic finish will require forming and carving relief into the shotcrete face to the limits shown on the plans. The relief shall be sculpted into shotcrete applied onto the structural shotcrete facing or onto a substrate suitable to sustain the sculpted shotcrete with anti-graffiti coating. The texture shall closely resemble that of the approved mock-ups

305-3.4.1 Submittals

1. Submittals shall be made in accordance with 2-5.3, "Submittals".
2. The Contractor shall submit three (3) sets of construction details listing shotcrete mix design, stain colors, paints and MSDS data sheets at least two weeks prior to the beginning of wall construction.
3. The Contractor shall build a mock-up sample test panel 4' wide x 10' high section of architectural concrete wall finish at the site for review and approval by the Engineer prior to construction.
4. Test panels or photo simulations shall represent a small section of each sculpted rock finish. The test panels shall be used as a visual reference throughout the construction of the architectural finish.

305-3.4.2 Shotcrete Staining

1. Prior to staining, all permanently exposed shotcrete surfaces shall be cleaned and pressure washed with the water to remove laitance and provide a clean surface. Sandblasting will not be required.
2. Application of stain shall be by air-type sprayer. Shotcrete shall be cured a minimum of one (1) days prior to staining.

3. Shotcrete staining shall consist of applying a minimum of two separate applications of at least two multiple stain colors to all sculpted shotcrete (architectural surface treatment) such that the sculpted wall face demonstrates individual color variations and character to match that of the existing field variations and character to match that of the existing field conditions.

Staining shall only be performed when the entire sculpting is complete and not performed during sculpting construction. The test panel shall reflect the color variations and patterns of natural rock formations.

4. Coating with anti-graffiti coating shall be performed on all portions of the wall once the minimum cure time has been met.
5. The stains shall consist of a base and accent stain material. The base stain shall be an organic based non-toxic iron-oxide derivative that provides a spectrum of earth tones. The first coat shall consist of lighter earth tone. The second application of stain shall consist of darker accent stain to create darker tones and for highlighting.
6. The accent stain shall be hydrochloric acid with chromic, Cupric, Ferrous, Ferric, Manganese chloride stain with Sodium Dichromate. The stain shall be applied to replicate a close resemblance to the sculpted test panel. Caution shall be exercised to provide all necessary protection to the body during application. A copy of such printed material shall be furnished to the Engineer prior to application of the material. The stain material shall produce a spectrum of brown earth tone colors.

305-3.4.3 Cleanup. Upon completion of soil stabilization and work specified herein, the Contractor shall dispose of all excess materials off the jobsite and the jobsite shall be left in a clean and orderly condition ready for subsequent work operations.

305-3.5 Measurement and Payment. The payment for bid items shall be included in the Contract Price as bid by you. Except as specifically agreed to by the City in writing, you are not entitled to any additional payment. Do not invoice for any Work under this Contract until you have provided, and the City has approved, all required items listed under the bid

1. Payment for soil nails will be made per nail installed in accordance with the Bid Schedule based on the depth of the nail embedment. Each soil nail installation shall include plates and installation of steel reinforcement attachment, nail testing, and cleanup.

BID DESCRIPTION	UNIT
Soil Nailing - 33' Deep	EA
Soil Nailing - 36' Deep	EA
Soil Nailing - 40' Deep	EA

BID DESCRIPTION	UNIT
Soil Nail Testing – Verification Tests	EA
Soil Nail Testing – Proof Tests	EA
Soil Nail Testing – Performance Tests	EA

2. The contract price paid for pneumatically placed concrete shall be for the complete installation per the unit price in accordance with the bid schedule and include full compensation for furnishing all labor, materials, tools, equipment, and incidentals, and for the work involved in forms, joints, mixing, preparation of foundation, installation of steel reinforcement, and finishing as stated in the Specifications and the manufacturer’s specifications, and as directed by the Resident Engineer for pneumatically placed concrete.

The contract price paid for veneer assemblies shall be for the complete installation of the sculpted rock finish with anti-graffiti in accordance with the unit price in the bid schedule, and shall include compensation for furnishing all labor, materials, tools, equipment, and incidentals, including mock-ups, samples and submittals as stated in the Specifications and the manufacturer’s specifications, and as directed by the Resident Engineer for veneer assemblies.

Full compensation for shotcrete used to fill voids created by the removal of cobbles and boulders or other obstructions shall be considered as included in the contract price paid per cubic yard for structure backfill and no additional compensation will be allowed therefore.

BID DESCRIPTION	UNIT
4" minimum Shotcrete – Primary Structural Fascia & Rebar/WWM	CY
10" minimum thick Shotcrete – Rebar & Misc Metal Works for Arch Fascia	CY
Sculpted Rock Finish and Stained	SF
Structural Backfill	CY
Anti-Graffiti Coating	SF

3. The contract price paid for the wall drain system shall be for the complete installation per the unit price in accordance with the bid schedule and include full compensation for furnishing all labor, materials, tools, equipment, and incidentals, and for the work involved in geocomposite drains, anchors, membranes and gravel, 3-inch diameter Schedule 40 PVC weepholes, and connections as stated in the Specifications and the manufacturer’s specifications, and as directed by the Resident Engineer for the wall drain system.

specifications, and as directed by the Resident Engineer for the wall drain system.

BID DESCRIPTION	UNIT
Construct Wall Drain System	LS

5. The contract price paid for safety railing shall be for the complete installation per the unit price in accordance with the bid schedule and include full compensation for furnishing all labor, materials, tools, equipment, and incidentals, and for the work involved in assembly, alignment, placing the appropriate foundation along the shotcrete wall, curing, and finishing as stated in the Specifications and the manufacturer's specifications, and as directed by the Resident Engineer for safety railing.

BID DESCRIPTION	UNIT
Cable and Rail Post - 42" High	LF

SECTION 306 - OPEN TRENCH CONDUIT CONSTRUCTION

306-7.8.2.1 General. To the "WHITEBOOK", item 2, ADD the following:

- a) Specified test pressure for Class 235 pipe shall be 150 psi.
- b) Specified test pressure for Class 305 pipe shall be 200 psi.

306-15.6 Hydrants. To the "WHITEBOOK", ADD the following:

5. Payment for the relocation of fire hydrants shall be included in the Bid item for "Relocate Fire Hydrant".

ADD

306-15.13 Ductile Iron Water Pipeline Corrosion Protection. Payment for all corrosion protection will be made at a Lump Sum bid price for "Ductile Iron Water Pipeline Corrosion Protection"; which includes all necessary material, and all other work, as specified on the plans.

SECTION 314 - TRAFFIC STRIPING, CURB AND PAVEMENT MARKINGS, AND PAVEMENT MARKERS

314-2.3 **Payment.** To the "GREENBOOK", DELETE in its entirety and SUBSTITUTE with the following:

The Contract Lump Sum bid price for "Removal of Traffic Striping and Curb Markings" shall include full compensation for the type of traffic striping and curb markings shown in accordance with Plans on sheets **32132-T1-D thru 32132-T3-D**, Standard Specifications and these Special Provisions, and as directed by the Engineer.

314-4.3.7 **Payment.** To the "GREENBOOK", DELETE in its entirety and SUBSTITUTE with the following:

The Contract Lump Sum bid price for "Traffic Striping, Curb And Pavement Markings" shall include full compensation for furnishing all labor, materials, tools, equipment and incidentals, and for doing all the work involved in painting traffic stripes and bike lane striping, curb and pavement markings for the entire project, and the removal of all existing stripes and markings in conflict with the proposed plan or otherwise called out for removal, repainting, temporary striping, completed in place in accordance with Plans on sheets **39770-01-D thru 39770-19-D**, Standard Specifications and these Special Provisions, and as directed by the Engineer.

314-4.4.6 **Payment.** To the "WHITEBOOK", DELETE in its entirety and SUBSTITUTE with the following:

Painting traffic stripes, pavement markings, reflectors, raised reflective pavement markings including curb markings, curb painting, thermoplastic arrows, thermoplastic continental cross walks, arrows for the entire project and the removal of all existing stripes and markings in conflict with the proposed striping Plan, if needed, and the removal of all existing stripes and markups in conflict with proposed plan, or otherwise called out for removal and temporary striping, complete in place in accordance with the Plans on sheets **39770-01-D thru 39770-19-D**, the Standard Specifications, and these Special Provisions, and as directed by the Engineer shall be included in the Contract lump sum price for "Thermoplastic Traffic Striping".

SECTION 700 - MATERIALS

700-9.1 **Pedestrian Barricade.** To the "WHITEBOOK", DELETE in its entirety and SUBSTITUTE with the following:

1. Pedestrian barricades shall be constructed in accordance with the City of San Diego Standard Drawing SDE-103, "Pedestrian Barricade".
2. Assembly shall be commercial quality galvanized material.

SECTION 701 - CONSTRUCTION

701-1.2 Maintaining Existing and Temporary Electrical Systems. To the "WHITEBOOK", ADD the following:

Throughout the duration of the work, the intersection shall remain lighted at all times with existing or equivalent street lighting between the hours of 4:00 P.M. and 7:00 A.M. Shutdown of street lighting will be permitted daily from 7:00 A.M. to 4:00 P.M.

Owners of the various utilities on and near the job site are tabulated as follows:

UTILITY	OWNER
Electrical Power and Gas	San Diego Gas and Electric Company
Telephone Facilities	AT&T
Cable Television	Cox Cable/Charter Communications
Water, Sewer and Drainage	City of San Diego

The Contractor will be required to work around existing utilities. Where no relocation of such facilities is scheduled, this requirement shall exist for the total period of the Contract. Relocated utilities shall be protected as provided elsewhere in these Special Provisions, the State Standard Specifications and the City Standard Specifications.

701-2 PAYMENT. To the "WHITEBOOK", ADD the following:

19. An SDG&E service order will be provided to the Contractor. Payment for connecting to SDG&E and the new power service shall be paid by the Contractor out of the SDG&E Service Order Fee allowance.
20. The contract Lump Sum price paid for the "HAWK Traffic Signal & Street Lighting System" shall include full compensation for furnishing and installing signs included on sheet E-1, Pedestrian countdown timers (pedestrian signals), audible pedestrian signals (pedestrian pushbuttons), street light and traffic signal standards, poles and pedestals, vehicle detector loops, signal & lighting electrical service and switches, video detection, luminaries, lamps, ballasts, electrical conduits, conductors and cable, pull boxes, pull box adjustment to grade, traffic loops, signal heads, emergency vehicle preemption equipment, installation of new controller assembly, new conflict monitor unit, and all other such items as required on the Plans on sheets **39770-01-D thru 39770-19-D** and these Special Provisions necessary to provide a complete and operational traffic signal systems, except for Work covered in separate bid items. No additional compensation will be allowed.
21. The payment for Pedestrian Barricades shall be included in the Bid item for each "Pedestrian Barricade".

SECTION 901 – INSTALLATION AND CONNECTION

901-2.5 **Payment.** To the “WHITEBOOK”, item 3, DELETE in its entirety and SUBSTITUTE with the following:

3. Traffic control, saw cutting the trench area, trench caps, and other spot repairs in the vicinity of the disturbed area at each restored connection shall be included in the square foot Bid item for “Pavement Restoration for Final Connection”. Asphalt overlay and slurry seal Work shall be paid for under separate Bid items.

EQUAL OPPORTUNITY CONTRACTING PROGRAM (EOCP) SECTION A – GENERAL REQUIREMENTS

4.1 **Nondiscrimination in Contracting Ordinance.** To the “WHITEBOOK”, subsection 4.1.1, paragraph (2), sentence (1), DELETE in its entirety and SUBSTITUTE with the following:

You shall not discriminate on the basis of race, gender, gender expression, gender identity, religion, national origin, ethnicity, sexual orientation, age, or disability in the solicitation, selection, hiring, or treatment of subcontractors, vendors, or suppliers.

END OF SUPPLEMENTARY SPECIAL PROVISIONS (SSP)

SUPPLEMENTARY SPECIAL PROVISIONS

APPENDICES

APPENDIX A
MITIGATED NEGATIVE DECLARATION AND NOTICE OF EXEMPTION



THE CITY OF SAN DIEGO

M E M O R A N D U M

DATE: August 29, 2016

TO: Myra Herrmann, Senior Planner, Planning Department

FROM: Carrie Purcell, Principal Planner, City of San Diego – Public Works Department,
Environmental and Permit Support

SUBJECT: Torrey Pines Road Improvements Project Phase I: Project Modifications (Project No. 316432)

This memo provides a California Environmental Quality Act (CEQA) Section 15162 consistency evaluation for the proposed installation of new sidewalk with retaining curbs on the south side of Torrey Pines Road between Hillside Drive and Amalfi Street including curb ramps at Amalfi Street and at Hillside Drive; variable height retaining wall at the Hillside Drive curb return; replacement of two existing driveway approaches; installation of a pedestrian crossing on Torrey Pines Road immediately west of Princess Drive utilizing a HAWK (High-Intensity Activated Cross Walk) beacon with street lighting and crosswalk system inclusive of one mid-block curb ramp on the south side of Torrey Pines Road and one mid-block curb ramp on the north side of Torrey Pines Road including removal and replacement of adjacent curb, gutter, and sidewalk; asphalt concrete overlay with striping of buffered bike lanes along Torrey Pines Road from La Jolla Shores Drive to Princess Drive; removal of approximately 300 square-feet of raised median; and installation of a flush stamped and painted asphalt median between Roseland Drive and Hillside Drive (“proposed project” or “revised project”). The proposed project is related to the previously approved Torrey Pines Road Improvements Project Phase I (PTS No. 316432) roadway improvements which were evaluated under CEQA in a City of San Diego (City) Mitigated Negative Declaration (MND) dated April 2, 2004.

State CEQA Guidelines Section 15162 sets forth the criteria for determining the appropriate additional environmental documentation, if any, to be completed when there is a previously approved MND addressing the project for which a subsequent discretionary action is required. If impacts associated with the amended project are not related to substantial changes in the project that result in new significant impacts (or the increase in severity of previously identified impacts), the project may be found consistent with existing documentation and no new MND or addendum to the existing MND would be required.

Background

The MND for Torrey Pines Road Improvements Project Phase I (PTS No. 316432) was finalized on April 2, 2014 to allow for the replacement of damaged, settling sidewalks, curbs and gutters through construction of new and replacement sidewalks, curb ramps, cross gutters, Americans with Disabilities Act (ADA) compliant driveways and relocation of sidewalk obstructions (street lights, traffic signals and utility facilities). These improvements, which are entirely within the public right-of-way along Torrey Pines Road from Prospect Place to La Jolla Shores Drive, are further described below:

Sidewalk/Curb & Gutter Replacement: Approximately 2,000 square feet of sidewalk will be replaced due to damage or settling along Torrey Pines Road. Existing dry utilities and water meters affected will either be adjusted to meet grade or relocated. Approximately 50 linear feet of new curb and gutter will replace damaged curb and an unused driveway.

New Sidewalk: Approximately 1,800 square feet of new sidewalk will be installed from Roseland Drive to Calle Juela. Gravity retaining walls with a maximum height of 2 feet are required to provide enough spacing to construct the new sidewalks. Existing dry utilities and water meters affected will either be adjusted to meet grade or relocated. Existing trees and vegetation will be cut back to provide enough clearance for pedestrians using the path.

Curb Ramps: The project proposes 21 new curb ramps at the intersections along the corridor in order to provide safe access to the proposed walkways. Several of the new ramps require the removal of landscape in order to create the space necessary to build. Two curb ramps have been relocated and will require approximately 28 linear feet of new curb and gutter and sidewalk to replace the existing ramp locations. At the porkchop at the intersection of Torrey Pines and La Jolla Shores, a minor traffic signal and pedestrian signal pole are to be relocated to accommodate new ramps.

Driveway: Six existing driveways will be upgraded to become ADA compliant residential driveways. In order to create a flatter, accessible path, the new driveways will require a sawcut further up the driveway in order to meet the existing grade.

Cross Gutters: Two cross gutters are proposed to upgrade the drainage runoff at the intersections of Torrey Pines Road and Little Street and Torrey Pines Road and Calle Juela. The cross gutter at Torrey Pines Road and Calle Juela is located on a steep grade and will require the removal and replacement of AC pavement along Calle Juela in order to meet the new asphalt grade.

Utility Relocations: The new improvements create the need to relocate several utilities. Four steel street lights (which require a 5'-1" depth for base foundation) are to be relocated behind the sidewalk. Large utility boxes at the intersection of Torrey Pines and Coast Walk will be relocated outside the sidewalk.

Environmental Considerations

The proposed project incorporates existing conditions resulting from implementation of the previously approved project along Torrey Pines Road between Prospect Place and La Jolla Shores Drive. Existing conditions in the surrounding area are essentially the same as those identified in the MND. The MND identified potentially significant impacts related to historical resources (archaeology) with mitigation measures identified to reduce all potential impacts to below a level of significance. This issue area is evaluated in the MND and is assessed below for the proposed project revisions, to demonstrate consistency with the findings and conclusions in the MND.

Historical Resources (Archaeology)

The proposed project would not result in any new significant archaeological resource impacts or a substantial increase in the severity of the impacts identified in the MND. That is, with the exception of the two proposed HAWK beacon pole locations on the north and south sides of Torrey Pines Road near Princess Street, the proposed project would be limited to previously developed areas evaluated in the MND, and would not directly affect any areas containing potential sensitive archaeological resources along Torrey Pines Road. For the two proposed HAWK beacon pole locations, adjacent to the previously recorded site boundary for Site CA-SDI-39, a prehistoric/ethnohistoric village site, LSA Associates conducted auger testing at these two locations to determine the potential for subsurface cultural deposits. During the course of the auger testing investigation, no cultural resources, including midden/anthrosols, were encountered. Soils observed within the Auger 1 testing location (north side of Torrey Pines Road) appeared to be highly disturbed. Soils within the Auger 2 testing location (south side of Torrey Pines Road) were likely part of the original slope that was modified during the construction of Torrey Pines Road. The auger testing investigation confirmed that Site CA-SDI-39 is not present within the two proposed pole locations and, as such, the mitigation measures identified in the MND, under Historical Resources (Archaeology) and Historical Resources (Archaeological Monitoring) in Section C. Specific MMRP Issue Area Conditions/Requirements, would continue to reduce potential construction impacts on archaeological resources from the revised project to below a level of significance.

Conclusion

For the reasons described above, it is our recommendation that the proposed project is within the scope of, and consistent with, the MND for Torrey Pines Road Improvements Project Phase I. The proposed project, therefore, would not require a subsequent environmental document pursuant to CEQA Guidelines Section 15162.

If you are in agreement and can make a consistency determination, please complete the following, return a copy to me and please include one copy in the Planning/Environmental project file at DSD.



ADVANCED PLANNING & ENGINEERING
DIVISION
(619) 446-5460

FINAL MITIGATED NEGATIVE DECLARATION

Project No. 316432
SCH No. N/A

SUBJECT: TORREY PINES ROAD IMPROVEMENTS PROJECT PHASE I: CITY COUNCIL
APPROVAL to allow for the replacement of damaged, settling sidewalks, curbs and gutters through construction of new and replacement sidewalks, curb ramps, cross gutters, Americans with Disabilities Act (ADA)-compliant driveways and relocation of sidewalk obstructions (street lights, traffic signals and utility facilities). Phase I improvements, which will be entirely within the public right-of-way along Torrey Pines Road from Prospect Place to La Jolla Shores Drive (as further illustrated in Figures 1-5) are further described below. The roadway improvement project is not included on any Government Code listing of hazardous waste sites.

Sidewalk/Curb & Gutter Replacement: Approximately 2,000 square feet of sidewalk will be replaced due to damage or settling along Torrey Pines Road. Existing dry utilities and water meters affected will either be adjusted to meet grade or relocated. Approximately 50 linear feet of new curb and gutter will replace damaged curb and an unused driveway.

New Sidewalk: Approximately 1,800 square feet of new sidewalk will be installed from Roseland Drive to Calle Juela. Gravity retaining walls with a maximum height of 2' are required to provide enough spacing to construct the new sidewalks. Existing dry utilities and water meters affected will either be adjusted to meet grade or relocated. Existing trees and vegetation will be cut back to provide enough clearance for pedestrians using the path.

Curb Ramps: The project proposes 21 new curb ramps at the intersections along the corridor in order to provide safe access to the proposed walkways. Several of the new ramps require the removal of landscape in order to create the space necessary to build. Two curb ramps have been relocated and will require approximately 28 linear feet of new curb and gutter and sidewalk to replace the existing ramp locations. At the porkchop at the intersection of Torrey Pines and La Jolla Shores, a minor traffic signal and pedestrian signal pole are to be relocated to accommodate new ramps.

Driveway: Six existing driveways will be upgraded to become ADA compliant residential driveways. In order to create a flatter, accessible path, the new driveways will require a sawcut further up the driveway in order to meet the existing grade.

Cross Gutters: Two cross gutters are proposed to upgrade the drainage runoff at the intersections of Torrey Pines Road and Little Street and Torrey Pines Road and Calle Juela. The cross gutter at Torrey Pines Road and Calle Juela is located on a steep grade and will require the removal and replacement of AC pavement along Calle Juela in order to meet the new asphalt grade.

Utility Relocations: The new improvements create the need to relocate several utilities. Four steel street lights (which require a 5'1" depth for base foundation) are to be relocated behind the sidewalk. Large utility boxes at the intersection of Torrey Pines and Coast Walk will be relocated outside the sidewalk.

Applicant: City of San Diego, Public Works Department -Engineering and Capital Improvements Projects, Right of Way Design Division

- I. PROJECT DESCRIPTION: See attached Initial Study.
- II. ENVIRONMENTAL SETTING: See attached Initial Study.
- III. DETERMINATION:

The City of San Diego conducted an Initial Study which determined that several of the proposed projects could have a significant environmental effect in the following areas(s): HISTORICAL RESOURCES (ARCHAEOLOGY). The project proposal requires the implementation of specific mitigation identified in Section V of this Mitigated Negative Declaration (MND). The project as presented avoids or mitigates the potentially significant environmental effects identified, and the preparation of an Environmental Impact Report (EIR) would not be required.

- IV. DOCUMENTATION:

The attached Initial Study documents the reasons to support the above Determination.

- V. MITIGATION, MONITORING AND REPORTING PROGRAM:

A. GENERAL REQUIREMENTS – PART I

Plan Check Phase (prior to permit issuance)

1. Prior to the issuance Bid Opening/Bid Award or beginning any construction related activity on-site, the Development Services Department (DSD) Director's Environmental Designee (ED) shall review and approve all Construction Documents (CD), (plans, specification, details, etc.) to ensure the MMRP requirements have been incorporated.
2. In addition, the ED shall verify that the MMRP Conditions/Notes that apply ONLY to the construction phases of this project are included VERBATIM, under the heading, "ENVIRONMENTAL/MITIGATION REQUIREMENTS."

3. These notes must be shown within the first three (3) sheets of the construction documents in the format specified for engineering construction document templates as shown on the City website:

<http://www.sandiego.gov/development-services/industry/standtemp.shtml>

4. The **TITLE INDEX SHEET** must also show on which pages the "Environmental/Mitigation Requirements" notes are provided.

B. GENERAL REQUIREMENTS – PART II

Post Plan Check (After permit issuance/Prior to start of construction)

1. **PRE CONSTRUCTION MEETING IS REQUIRED TEN (10) WORKING DAYS PRIOR TO BEGINNING ANY WORK ON THIS PROJECT.** The PERMIT HOLDER/OWNER is responsible to arrange and perform this meeting by contacting the CITY RESIDENT ENGINEER (RE) of the Field Engineering Division and City staff from MITIGATION MONITORING COORDINATION (MMC). Attendees must also include the Permit holder's Representative(s), Job Site Superintendent and the following consultants:

Archaeologist and Native American Monitor

Note: Failure of all responsible Permit Holder's representatives and consultants to attend shall require an additional meeting with all parties present.

CONTACT INFORMATION:

- a) The PRIMARY POINT OF CONTACT is the **RE** at the **Field Engineering Division – 858-627-3200**
 - b) For Clarification of ENVIRONMENTAL REQUIREMENTS, it is also required to call **RE and MMC at 858-627-3360**
2. **MMRP COMPLIANCE:** This Project, Project Tracking System (PTS) 316432 shall conform to the mitigation requirements contained in the associated Environmental Document and implemented to the satisfaction of the DSD's ED, MMC and the City Engineer (RE). The requirements may not be reduced or changed but may be annotated (i.e. to explain when and how compliance is being met and location of verifying proof, etc.). Additional clarifying information may also be added to other relevant plan sheets and/or specifications as appropriate (i.e., specific locations, times of monitoring, methodology, etc)

Note:

Permit Holder's Representatives must alert RE and MMC if there are any discrepancies in the plans or notes, or any changes due to field conditions. All conflicts must be approved by RE and MMC BEFORE the work is performed.

3. **OTHER AGENCY REQUIREMENTS:** Evidence that any other agency requirements or permits have been obtained or are in process shall be submitted to the RE and MMC for review and acceptance prior to the beginning of work or within one week of the

Permit Holder obtaining documentation of those permits or requirements. Evidence shall include copies of permits, letters of resolution or other documentation issued by the responsible agency.

Not Applicable for this project.

4. **MONITORING EXHIBITS:** All consultants are required to submit, to RE and MMC, a monitoring exhibit on a 11x17 reduction of the appropriate construction plan, such as site plan, grading, landscape, etc., marked to clearly show the specific areas including the **LIMIT OF WORK**, scope of that discipline’s work, and notes indicating when in the construction schedule that work will be performed. When necessary for clarification, a detailed methodology of how the work will be performed shall be included.
5. **OTHER SUBMITTALS AND INSPECTIONS:** The Permit Holder/Owner’s representative shall submit all required documentation, verification letters, and requests for all associated inspections to the RE and MMC for approval per the following schedule:

Document Submittal/Inspection Checklist

<i>Issue Area</i>	<i>Document submittal</i>	<i>Associated Inspection/Approvals/Note</i>
General	Consultant Qualification Letters	Prior to Pre-construction Meeting
General	Consultant Const. Monitoring	Prior to or at Pre-Construction Meeting
Archaeology	Archaeology Reports	Archaeology observation
Final MMRP		Final MMRP Inspection

C. SPECIFIC MMRP ISSUE AREA CONDITIONS/REQUIREMENTS

HISTORICAL RESOURCES (ARCHAEOLOGY)

This Project requires implementation of an Archaeological Mitigation Program prior to the start of ANY construction. The Archaeological Monitoring Program with Native American participation shall provide the maximum opportunity to recover human remains and repatriate these remains with the Native American community. Because of the potential for Native American human burial remains in this area, and with respect to the cultural heritage of the local Kumeyaay people the governing protocol for the following locations affected by any ground disturbing activities in areas of the project where it overlaps with the southern boundary of the Spindrift Archaeological Site (CA-SDI-39/SDMM-W-1) shall be hand-excavated by archaeologists prior to the start of ANY construction to provide the greatest opportunity possible to identify and recover human remains:

Princess Street	(St #31+90)	Streetlight Relocation
Little Street	(St #43+25)	New Fire Hydrant

Any human remains if encountered shall be repatriated to the Kumeyaay representatives or MLD. Any discovery of such remains shall be treated in accordance with the protocol listed below and shall be implemented as described below after consultation with DSD ED in accordance with the Cultural Resources Report prepared by LSA Associates, Inc. (November 2013).

In addition, the following three streetlight locations SHALL have full-time archaeological and Native American monitoring during any and all ground-disturbing activities associated with the project:

Coast Walk (St #22+00)
Little Street (St #47+20)
Roseland Drive (St #50+00)

HISTORICAL RESOURCES (ARCHAEOLOGICAL MONITORING)

I. Prior to Permit Issuance or Bid Opening/Bid Award

- A. Entitlements Plan Check
 - 1. Prior to permit issuance or Bid Opening/Bid Award, whichever is applicable, the Assistant Deputy Director (ADD) Environmental designee shall verify that the requirements for Archaeological Monitoring and Native American monitoring have been noted on the applicable construction documents through the plan check process.
- B. Letters of Qualification have been submitted to ADD
 - 1. Prior to Bid Award, the applicant shall submit a letter of verification to Mitigation Monitoring Coordination (MMC) identifying the Principal Investigator (PI) for the project and the names of all persons involved in the archaeological monitoring program, as defined in the City of San Diego Historical Resources Guidelines (HRG). If applicable, individuals involved in the archaeological monitoring program must have completed the 40-hour HAZWOPER training with certification documentation.
 - 2. MMC will provide a letter to the applicant confirming the qualifications of the PI and all persons involved in the archaeological monitoring of the project meet the qualifications established in the HRG.
 - 3. Prior to the start of work, the applicant must obtain written approval from MMC for any personnel changes associated with the monitoring program.

II. Prior to Start of Construction

- A. Verification of Records Search
 - 1. The PI shall provide verification to MMC that a site specific records search (1/4 mile radius) has been completed. Verification includes, but is not limited to a copy of a confirmation letter from South Coastal Information Center, or, if the search was in-house, a letter of verification from the PI stating that the search was completed.
 - 2. The letter shall introduce any pertinent information concerning expectations and probabilities of discovery during trenching and/or grading activities.
 - 3. The PI may submit a detailed letter to MMC requesting a reduction to the ¼ mile radius.
- B. PI Shall Attend Precon Meetings
 - 1. Prior to beginning any work that requires monitoring; the Applicant shall arrange a Precon Meeting that shall include the PI, Native American consultant/monitor (where Native American resources may be impacted), Construction Manager (CM) and/or Grading Contractor, Resident Engineer (RE), Building Inspector (BI), if appropriate, and MMC. The qualified Archaeologist and Native American Monitor shall attend any grading/excavation related Precon Meetings to make comments and/or suggestions concerning the Archaeological Monitoring program with the Construction Manager and/or Grading Contractor.
 - a. If the PI is unable to attend the Precon Meeting, the Applicant shall schedule a focused Precon Meeting with MMC, the PI, RE, CM or BI, if appropriate, prior to the start of any work that requires monitoring.

2. Acknowledgement of Responsibility for Curation (CIP or Other Public Projects)

The applicant shall submit a letter to MMC acknowledging their responsibility for the cost of curation associated with all phases of the archaeological monitoring program.
3. Identify Areas to be Monitored
 - a. Prior to the start of any work that requires monitoring, the PI shall submit an Archaeological Monitoring Exhibit (AME) (with verification that the AME has been reviewed and approved by the Native American consultant/monitor when Native American resources may be impacted) based on the appropriate construction documents (reduced to 11x17) to MMC identifying the areas to be monitored including the delineation of grading/excavation limits.
 - b. The AME shall be based on the results of a site specific records search as well as information regarding the age of existing pipelines, laterals and associated appurtenances and/or any known soil conditions (native or formation).
 - c. MMC shall notify the PI that the AME has been approved.
4. When Monitoring Will Occur
 - a. Prior to the start of any work, the PI shall also submit a construction schedule to MMC through the RE indicating when and where monitoring will occur.
 - b. The PI may submit a detailed letter to MMC prior to the start of work or during construction requesting a modification to the monitoring program. This request shall be based on relevant information such as review of final construction documents which indicate conditions such as age of existing pipe to be replaced, depth of excavation and/or site graded to bedrock, etc., which may reduce or increase the potential for resources to be present.
5. Approval of AME and Construction Schedule

After approval of the AME by MMC, the PI shall submit to MMC written authorization of the AME and Construction Schedule from the CM.

III. During Construction

- A. Monitor Shall be Present During Grading/Excavation/Trenching
 1. The Archaeological Monitor shall be present full-time during all soil disturbing and grading/excavation/trenching activities which could result in impacts to archaeological resources as identified on the AME. **The Construction Manager is responsible for notifying the RE, PI, and MMC of changes to any construction activities such as in the case of a potential safety concern within the area being monitored. In certain circumstances OSHA safety requirements may necessitate modification of the AME.**
 2. The Native American consultant/monitor shall determine the extent of their presence during soil disturbing and grading/excavation/trenching activities based on the AME and provide that information to the PI and MMC. If prehistoric resources are encountered during the Native American consultant/monitor's absence, work shall stop and the Discovery Notification Process detailed in Section III.B-C and IV.A-D shall commence.
 3. The PI may submit a detailed letter to MMC during construction requesting a modification to the monitoring program when a field condition such as modern disturbance post-dating the previous grading/trenching activities, presence of fossil formations, or when native soils are encountered that may reduce or increase the potential for resources to be present.
 4. The archaeological and Native American consultant/monitor shall document field activity via the Consultant Site Visit Record (CSVR). The CSVR's shall be faxed by the CM to the RE the first day of monitoring, the last day of monitoring, monthly (**Notification of Monitoring Completion**), and in the case of ANY discoveries. The RE shall forward copies to MMC.
- B. Discovery Notification Process
 1. In the event of a discovery, the Archaeological Monitor shall direct the contractor to temporarily divert all soil disturbing activities, including but not limited to digging, trenching,

excavating or grading activities in the area of discovery and in the area reasonably suspected to overlay adjacent resources and immediately notify the RE or BI, as appropriate.

2. The Monitor shall immediately notify the PI (unless Monitor is the PI) of the discovery.
 3. The PI shall immediately notify MMC by phone of the discovery, and shall also submit written documentation to MMC within 24 hours by fax or email with photos of the resource in context, if possible.
 4. No soil shall be exported off-site until a determination can be made regarding the significance of the resource specifically if Native American resources are encountered.
- C. Determination of Significance
1. The PI and Native American consultant/monitor, where Native American resources are discovered shall evaluate the significance of the resource. If Human Remains are involved, follow protocol in Section IV below.
 - a. The PI shall immediately notify MMC by phone to discuss significance determination and shall also submit a letter to MMC indicating whether additional mitigation is required.
 - b. If the resource is significant, the PI shall submit an Archaeological Data Recovery Program (ADRP) and obtain written approval of the program from MMC, CM and RE. ADRP and any mitigation must be approved by MMC, RE and/or CM before ground disturbing activities in the area of discovery will be allowed to resume. **Note: If a unique archaeological site is also an historical resource as defined in CEQA Section 15064.5, then the limits on the amount(s) that a project applicant may be required to pay to cover mitigation costs as indicated in CEQA Section 21083.2 shall not apply.**
 - (1). Note: For pipeline trenching and other linear projects in the public Right-of-Way, the PI shall implement the Discovery Process for Pipeline Trenching projects identified below under "D."
 - c. If the resource is not significant, the PI shall submit a letter to MMC indicating that artifacts will be collected, curated, and documented in the Final Monitoring Report. The letter shall also indicate that that no further work is required.
 - (1). Note: For Pipeline Trenching and other linear projects in the public Right-of-Way, if the deposit is limited in size, both in length and depth; the information value is limited and is not associated with any other resource; and there are no unique features/artifacts associated with the deposit, the discovery should be considered not significant.
 - (2). Note, for Pipeline Trenching and other linear projects in the public Right-of-Way, if significance cannot be determined, the Final Monitoring Report and Site Record (DPR Form 523A/B) shall identify the discovery as Potentially Significant.
- D. Discovery Process for Significant Resources - Pipeline Trenching and other Linear Projects in the Public Right-of-Way
- The following procedure constitutes adequate mitigation of a significant discovery encountered during pipeline trenching activities or for other linear project types within the Public Right-of-Way including but not limited to excavation for jacking pits, receiving pits, laterals, and manholes to reduce impacts to below a level of significance:
1. Procedures for documentation, curation and reporting
 - a. One hundred percent of the artifacts within the trench alignment and width shall be documented in-situ, to include photographic records, plan view of the trench and profiles of side walls, recovered, photographed after cleaning and analyzed and curated. The remainder of the deposit within the limits of excavation (trench walls) shall be left intact.
 - b. The PI shall prepare a Draft Monitoring Report and submit to MMC via the RE as indicated in Section VI-A.
 - c. The PI shall be responsible for recording (on the appropriate State of California Department of Park and Recreation forms-DPR 523 A/B) the resource(s) encountered during the Archaeological Monitoring Program in accordance with the City's Historical Resources

Guidelines. The DPR forms shall be submitted to the South Coastal Information Center for either a Primary Record or SDI Number and included in the Final Monitoring Report.

- d. The Final Monitoring Report shall include a recommendation for monitoring of any future work in the vicinity of the resource.

IV. Discovery of Human Remains

If human remains are discovered, work shall halt in that area and no soil shall be exported off-site until a determination can be made regarding the provenance of the human remains; and the following procedures as set forth in CEQA Section 15064.5(e), the California Public Resources Code (Sec. 5097.98) and State Health and Safety Code (Sec. 7050.5) shall be undertaken:

A. Notification

1. Archaeological Monitor shall notify the RE or BI as appropriate, MMC, and the PI, if the Monitor is not qualified as a PI. MMC will notify the appropriate Senior Planner in the Environmental Analysis Section (EAS) of the Development Services Department to assist with the discovery notification process.
2. The PI shall notify the Medical Examiner after consultation with the RE, either in person or via telephone.

B. Isolate discovery site

1. Work shall be directed away from the location of the discovery and any nearby area reasonably suspected to overlay adjacent human remains until a determination can be made by the Medical Examiner in consultation with the PI concerning the provenience of the remains.
2. The Medical Examiner, in consultation with the PI, will determine the need for a field examination to determine the provenience.
3. If a field examination is not warranted, the Medical Examiner will determine with input from the PI, if the remains are or are most likely to be of Native American origin.

C. If Human Remains **ARE** determined to be Native American

1. The Medical Examiner will notify the Native American Heritage Commission (NAHC) within 24 hours. By law, **ONLY** the Medical Examiner can make this call.
2. NAHC will immediately identify the person or persons determined to be the Most Likely Descendent (MLD) and provide contact information.
3. The MLD will contact the PI within 24 hours or sooner after the Medical Examiner has completed coordination, to begin the consultation process in accordance with CEQA Section 15064.5(e), the California Public Resources and Health & Safety Codes.
4. The MLD will have 48 hours to make recommendations to the property owner or representative, for the treatment or disposition with proper dignity, of the human remains and associated grave goods.
5. Disposition of Native American Human Remains will be determined between the MLD and the PI, and, if:
 - a. The NAHC is unable to identify the MLD, OR the MLD failed to make a recommendation within 48 hours after being notified by the Commission, OR;
 - b. The landowner or authorized representative rejects the recommendation of the MLD and mediation in accordance with PRC 5097.94 (k) by the NAHC fails to provide measures acceptable to the landowner, THEN
 - c. To protect these sites, the landowner shall do one or more of the following:
 - (1) Record the site with the NAHC;
 - (2) Record an open space or conservation easement; or
 - (3) Record a document with the County.
 - d. Upon the discovery of multiple Native American human remains during a ground disturbing land development activity, the landowner may agree that additional conferral with descendants is necessary to consider culturally appropriate treatment of multiple Native American human remains. Culturally appropriate treatment of such a discovery may be ascertained from review of the site utilizing cultural and archaeological standards.

Where the parties are unable to agree on the appropriate treatment measures the human remains and buried with Native American human remains shall be reinterred with appropriate dignity, pursuant to Section 5.c., above.

- D. If Human Remains are **NOT** Native American
 - 1. The PI shall contact the Medical Examiner and notify them of the historic era context of the burial.
 - 2. The Medical Examiner will determine the appropriate course of action with the PI and City staff (PRC 5097.98).
 - 3. If the remains are of historic origin, they shall be appropriately removed and conveyed to the San Diego Museum of Man for analysis. The decision for internment of the human remains shall be made in consultation with MMC, EAS, the applicant/landowner, any known descendant group, and the San Diego Museum of Man.

V. Night and/or Weekend Work

- A. If night and/or weekend work is included in the contract
 - 1. When night and/or weekend work is included in the contract package, the extent and timing shall be presented and discussed at the precon meeting.
 - 2. The following procedures shall be followed.
 - a. No Discoveries
In the event that no discoveries were encountered during night and/or weekend work, the PI shall record the information on the CSVN and submit to MMC via fax by 8AM of the next business day.
 - b. Discoveries
All discoveries shall be processed and documented using the existing procedures detailed in Sections III - During Construction, and IV – Discovery of Human Remains. Discovery of human remains shall always be treated as a significant discovery.
 - c. Potentially Significant Discoveries
If the PI determines that a potentially significant discovery has been made, the procedures detailed under Section III - During Construction and IV-Discovery of Human Remains shall be followed.
 - d. The PI shall immediately contact the RE and MMC, or by 8AM of the next business day to report and discuss the findings as indicated in Section III-B, unless other specific arrangements have been made.
- B. If night and/or weekend work becomes necessary during the course of construction
 - 1. The Construction Manager shall notify the RE, or BI, as appropriate, a minimum of 24 hours before the work is to begin.
 - 2. The RE, or BI, as appropriate, shall notify MMC immediately.
- C. All other procedures described above shall apply, as appropriate.

VI. Post Construction

- A. Submittal of Draft Monitoring Report
 - 1. The PI shall submit two copies of the Draft Monitoring Report (even if negative), prepared in accordance with the Historical Resources Guidelines (Appendix C/D) which describes the results, analysis, and conclusions of all phases of the Archaeological Monitoring Program (with appropriate graphics) to MMC via the RE for review and approval within 90 days following the completion of monitoring. **It should be noted that if the PI is unable to submit the Draft Monitoring Report within the allotted 90-day timeframe as a result of delays with analysis, special study results or other complex issues, a schedule shall be submitted to MMC establishing agreed due dates and the provision for submittal of monthly status reports until this measure can be met.**
 - a. For significant archaeological resources encountered during monitoring, the Archaeological Data Recovery Program or Pipeline Trenching Discovery Process shall be included in the Draft Monitoring Report.

- b. Recording Sites with State of California Department of Parks and Recreation
The PI shall be responsible for recording (on the appropriate State of California Department of Park and Recreation forms-DPR 523 A/B) any significant or potentially significant resources encountered during the Archaeological Monitoring Program in accordance with the City's Historical Resources Guidelines, and submittal of such forms to the South Coastal Information Center with the Final Monitoring Report.
 - 2. MMC shall return the Draft Monitoring Report to the PI via the RE for revision or, for preparation of the Final Report.
 - 3. The PI shall submit revised Draft Monitoring Report to MMC via the RE for approval.
 - 4. MMC shall provide written verification to the PI of the approved report.
 - 5. MMC shall notify the RE or BI, as appropriate, of receipt of all Draft Monitoring Report submittals and approvals.
- B. Handling of Artifacts
- 1. The PI shall be responsible for ensuring that all cultural remains collected are cleaned and catalogued
 - 2. The PI shall be responsible for ensuring that all artifacts are analyzed to identify function and chronology as they relate to the history of the area; that faunal material is identified as to species; and that specialty studies are completed, as appropriate.
- C. Curation of artifacts: Accession Agreement and Acceptance Verification
- 1. The PI shall be responsible for ensuring that all artifacts associated with the survey, testing and/or data recovery for this project are permanently curated with an appropriate institution. This shall be completed in consultation with MMC and the Native American representative, as applicable.
 - 2. When applicable to the situation, the PI shall include written verification from the Native American consultant/monitor indicating that Native American resources were treated in accordance with state law and/or applicable agreements. If the resources were reinterred, verification shall be provided to show what protective measures were taken to ensure no further disturbance occurs in accordance with Section IV – Discovery of Human Remains, Subsection C.
 - 3. The PI shall submit the Accession Agreement and catalogue record(s) to the RE or BI, as appropriate for donor signature with a copy submitted to MMC.
 - 4. The RE or BI, as appropriate shall obtain signature on the Accession Agreement and shall return to PI with copy submitted to MMC.
 - 5. The PI shall include the Acceptance Verification from the curation institution in the Final Monitoring Report submitted to the RE or BI and MMC.
- D. Final Monitoring Report(s)
- 1. The PI shall submit one copy of the approved Final Monitoring Report to the RE or BI as appropriate, and one copy to MMC (even if negative), within 90 days after notification from MMC of the approved report.
 - 2. The RE shall, in no case, issue the Notice of Completion until receiving a copy of the approved Final Monitoring Report from MMC which includes the Acceptance Verification from the curation institution.

VI. PUBLIC REVIEW DISTRIBUTION:

Draft copies or notice of this Mitigated Negative Declaration were distributed to:

State of California
Native American Heritage Commission (56)

City of San Diego:

Mayor's Office (91)
Councilmember Sherri Lightner, District 1

City Attorney

Shannon Thomas
Development Services Department
Myra Herrmann, Senior Environmental Planner
Helene Deisher, Development Project Manager
Gary Geiler
Mitigation Monitoring Coordination
Mehdi Rastakhiz
Public Works Department - Engineering and Capital Projects
David Li
Brad Johnson
Juan Baligad
Peter Fogec
Transportation & Storm Water Department
Mario Reyes
Linda Marabian
Anne Jarque
Library Department – Government Documents (MS 17)
La Jolla/Riford City Branch Library (81L)
Historical Resources Board (87)
Real Estate Assets Department (85)
Fire & Life Safety (MS 603)

Other Groups and Individuals

San Diego Transit Corporation (112)
San Diego Gas and Electric (SDGE) (114)
Carmen Lucas (206)
South Coastal Information Center @ San Diego University (210)
San Diego Archaeological Center (212)
Save Our Heritage Organization (214)
Ron Christman (215)
Clint Linton (215B)
Frank Brown – Inter-Tribal Cultural Resource Council (216)
Campo Band of Mission Indians (217)
San Diego County Archaeological Society (218)
Kumeyaay Cultural Heritage Preservation (223)
Kumeyaay Cultural Repatriation Committee (225)
Native American Distribution (225A-S Public Notice only)
Barona Group of Capitan Grande Band of Mission Indians (225A)
Campo Band of Mission Indians (225B)
Ewiiapaayp Band of Mission Indians (225C)
Inaja Band of Mission Indians (225D)
Jamul Indian Village (225E)
La Posta Band of Mission Indians (225F)
Manzanita Band of Mission Indians (225G)
Sycuan Band of Mission Indians (225H)

Viejas Group of Capitan Grande Band of Mission Indians (225I)
Mesa Grande Band of Mission Indians (225J)
San Pasqual Band of Mission Indians (225K)
Ipai Nation of Santa Ysabel (225L)
La Jolla Band of Mission Indians (225M)
Pala Band of Mission Indians (225N)
Pauma Band of Mission Indians (225O)
Pechanga Band of Mission Indians (225P)
Rincon Band of Luiseno Indians (225Q)
San Luis Rey Band of Luiseno Indians (225R)
Los Coyotes Band of Mission Indians (225S)
La Jolla Village News (271)
La Jolla Shores Association (272)
La Jolla Town Council (273)
La Jolla Historical Society (274)
La Jolla Community Planning Association (275)
La Jolla Shores PDO Advisory Board (279)
La Jolla Light (280)
LSA Associates, Inc. (Consulting Archaeologist)

VII. RESULTS OF PUBLIC REVIEW:

- No comments were received during the public input period.
- Comments were received but did not address the draft Mitigated Negative Declaration finding or the accuracy/completeness of the Initial Study. No response is necessary. The letters are attached.
- Comments addressing the findings of the draft Mitigated Negative Declaration and/or accuracy or completeness of the Initial Study were received during the public input period. The letters and responses follow.

Copies of the Draft Mitigated Negative Declaration, the Mitigation, Monitoring and Reporting Program and any Initial Study materials are available in the office of the Advanced Planning & Engineering Division for review, or for purchase at the cost of reproduction.

Myra Herrmann, Senior Planner
Development Services Department

March 5, 2014
Date of Draft Report

April 2, 2014
Date of Final Report

Analyst: Herrmann

Attachments: Figure 1 – Location Map
Figures 2-5 – Project Details
Initial Study Checklist

Torrey Pines Road Improvements Phase 2 and Torrey Pines Road Slope Restoration
Appendix A - Mitigated Negative Declaration and Notice of Exemption



PO Box 908
Alpine, CA 91903
#1 Viejas Grade Road
Alpine, CA 91901

Phone: 6194453819
Fax: 6194453337
viejas.com

March 11, 2014

Ms. Myra Herrmann
City of San Diego
1222 First Avenue, MS501
San Diego, CA 92101

RE: Torrey Pines Road Improvements Phase I

Dear Ms. Herrmann,

The Viejas Band of Kumeyaay Indians ("Viejas") has reviewed the proposed project and at this time we have determined that the project site is has cultural significance or ties to Viejas. Viejas Band request that a Native American Cultural Monitor be on site for all ground disturbing activities to inform us of any new developments such as inadvertent discovery of cultural artifacts, cremation sites, or human remains. Please call Julie Hagen for scheduling at 619-659-2339 or email jhagen@viejas-nsn.gov. Thank you

Sincerely,

VIEJAS BAND OF KUMEYAAY INDIANS

VIEJAS TRIBAL GOVERNMENT
(MARCH 11, 2014)

1. Comment acknowledged. Native American cultural monitoring is always required whenever a public or private project requires the presence of an archaeologist in conjunction with any archaeological investigations or mitigation monitoring. This requirement is clearly stated in the Final MND, Mitigation Monitoring and Reporting Program and will be incorporated into contract documents and specifications for approval by the City Council.

LETTER

RESPONSE

Torrey Pines Road Improvements Phase 2 and Torrey Pines Road Slope Restoration
Appendix A - Mitigated Negative Declaration and Notice of Exemption



San Diego County Archaeological Society, Inc.

Environmental Review Committee

13 March 2013

To: Ms. Myra Herrmann
Development Services Department
City of San Diego
1222 First Avenue, Mail Station 501
San Diego, California 92101

Subject: Draft Mitigated Negative Declaration
Torrey Pines Road Improvements, Phase I
Project No. 316432

Dear Ms. herrmann:

I have reviewed the subject DMND on behalf of this committee of the San Diego County Archaeological Society.

2. [Based on the information contained in the DMND and the cultural resources constraints analysis for the project, we concur with the impact analysis and the mitigation measures as proposed.

SDCAS appreciates being afforded the opportunity to review and comment upon this project's environmental documents.

Sincerely,

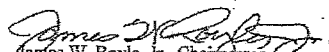

James W. Royle, Jr., Chairperson
Environmental Review Committee

cc: LSA
SDCAS President
File

P.O. Box 81108 San Diego, CA 92138-1106 (619) 538-0935

SAN DIEGO COUNTY ARCHAEOLOGICAL SOCIETY
(MARCH 13, 2014)

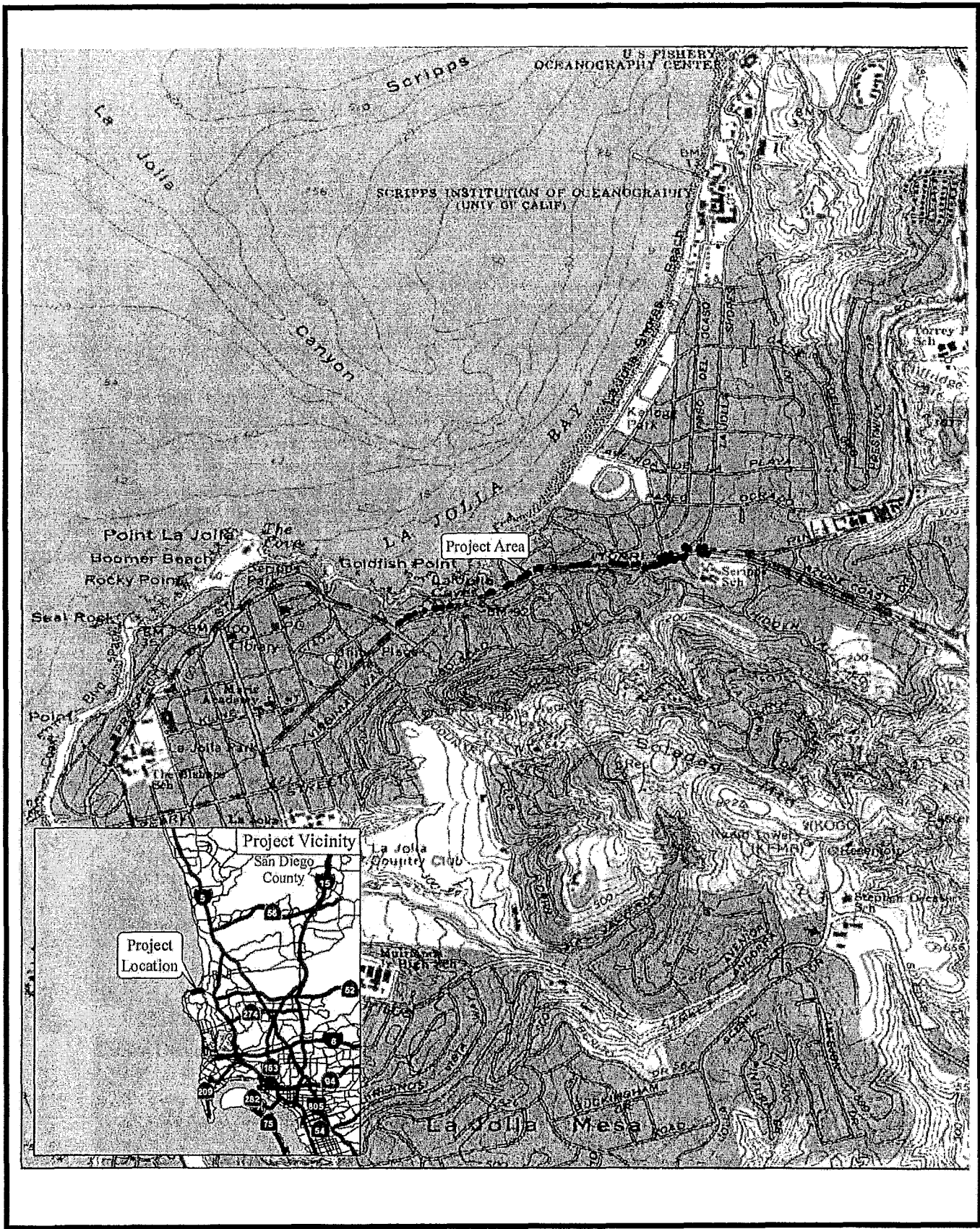
2. Comment noted.



LOCATION MAP

Torrey Pines Road Improvements Project No. 316432
 City of San Diego – Development Services Department

Torrey Pines Road Improvements Phase 2 and Torrey Pines Road Slope Restoration
 Appendix A - Mitigated Negative Declaration and Notice of Exemption

FIGURE

No. 1

85 | Page

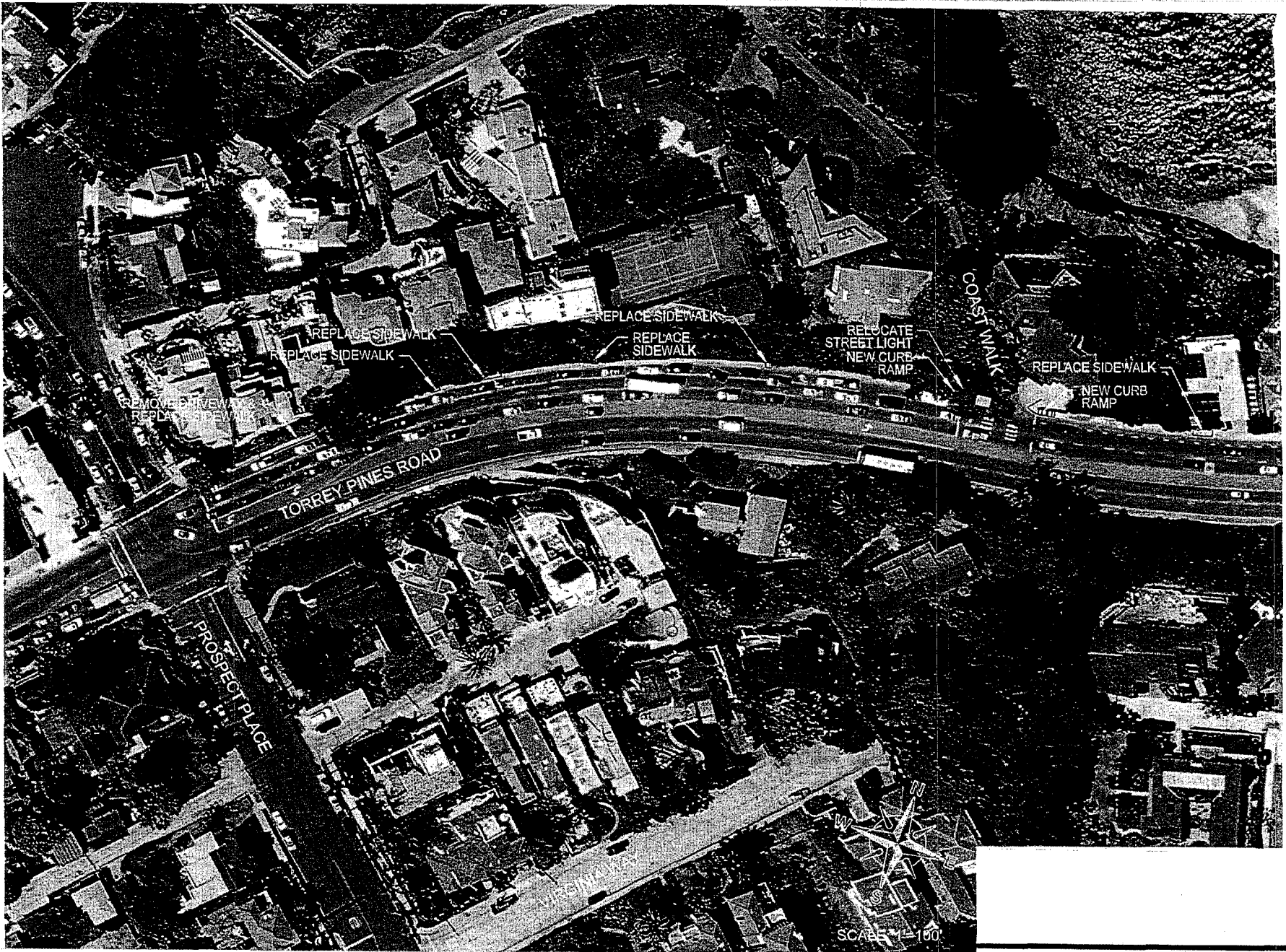

Project Details - Prospect Place to NE of Coast Walk
Torrey Pines Road Improvements Project No. 316432
City of San Diego – Development Services Department

FIGURE
No. 2

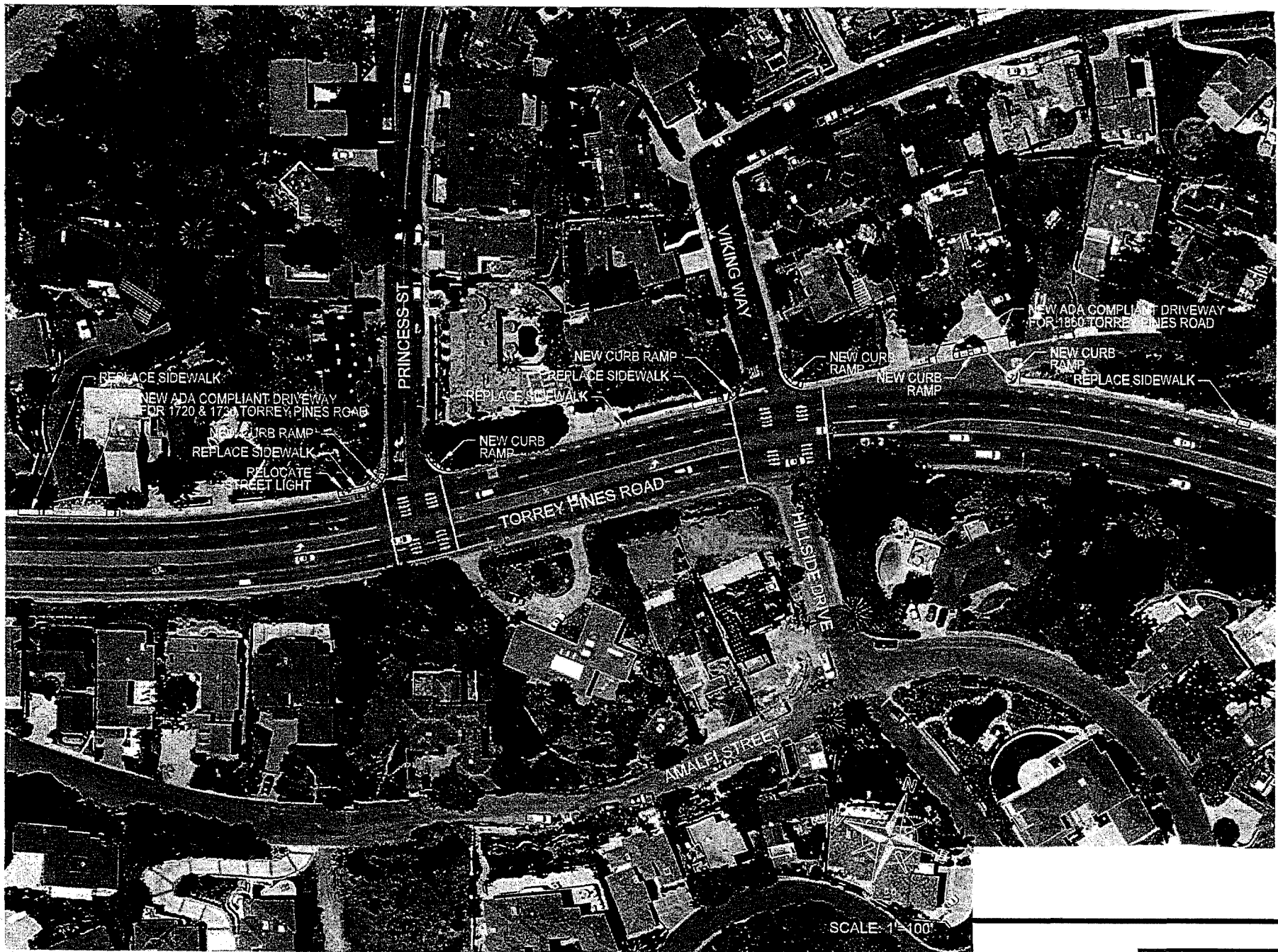

Project Details - NE of Coast Walk to NE of Viking Way
 Torrey Pines Road Improvements Project No. 316432
 City of San Diego – Development Services Department

FIGURE
No. 3



Project Details - NW of Little Street to NE of Little Street
Torrey Pines Road Improvements Project No. 316432
City of San Diego – Development Services Department

FIGURE
No.4

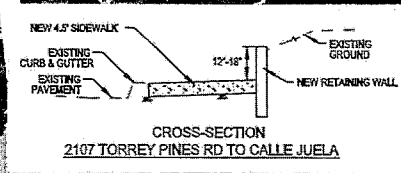
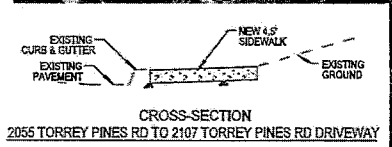
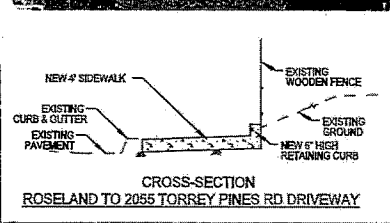
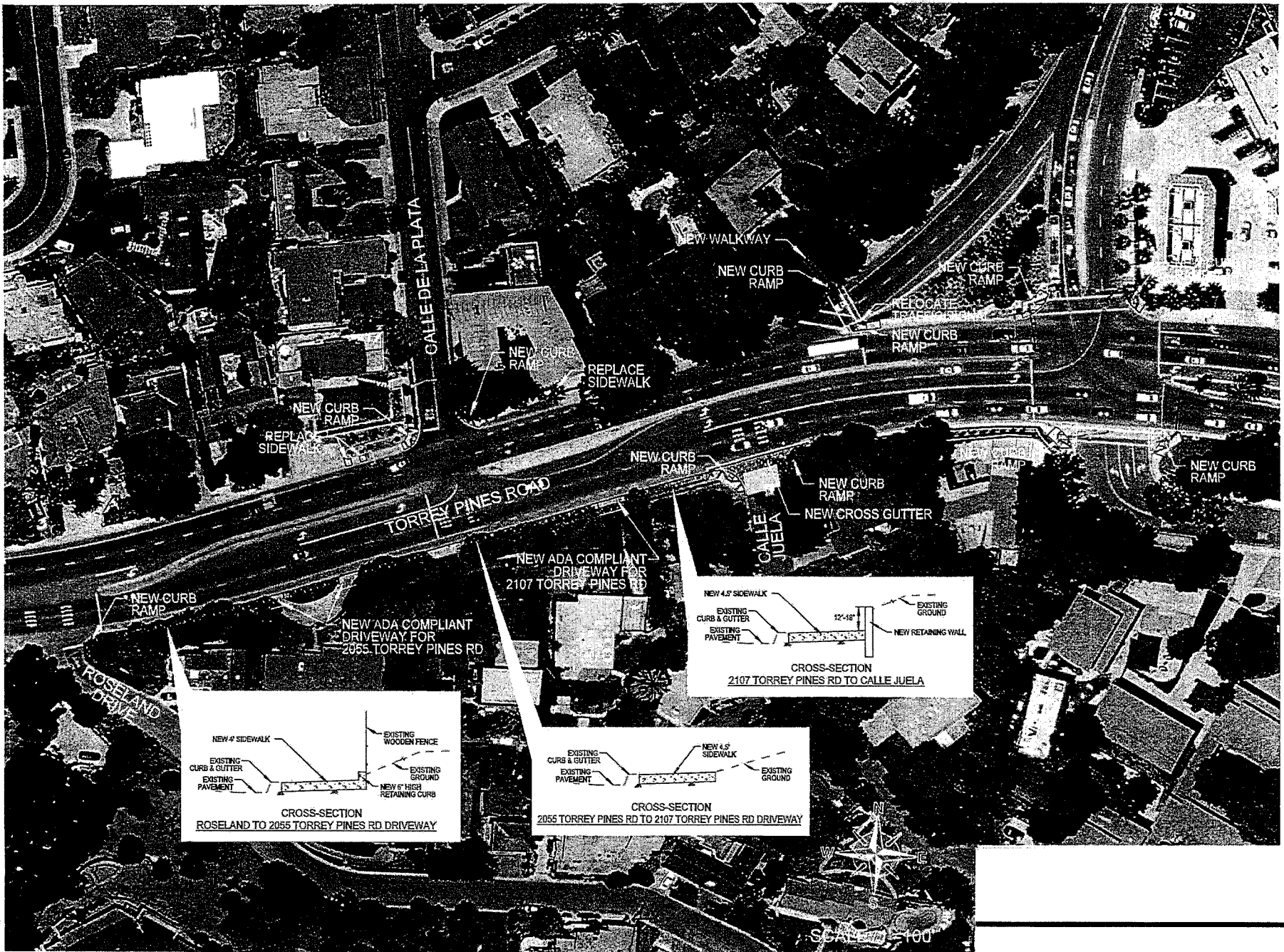

Project Details -Roseland Dr. to Calle Juella; Calle de la Plata to La Jolla Shores Dr.
 Torrey Pines Road Improvements Project No. 316432
 City of San Diego – Development Services Department

**FIGURE
 No. 5**

INITIAL STUDY CHECKLIST

1. Project Title/Project Number: TORREY PINES ROADWAY IMPROVEMENTS PHASE I/316432
2. Lead agency name and address: City of San Diego, Development Services Department,
1222 First Avenue, MS 501, San Diego, CA 92101
3. Contact person and phone number: Myra Herrmann, Senior Planner, 619-446-5372
4. Project location: All work will be entirely within the public right-of-way along Torrey Pines Road from Prospect Place to La Jolla Shores Drive (as further illustrated in Figures 1-5).
5. Project Applicant/Sponsor's name and address:
David Li, Associate Engineer,
City of San Diego, Public Works-Engineering and Capital Projects Department
Right-of-Way Design Division
525 B St. Mail Station 908A, San Diego, CA 92101
619-533-5164
6. General Plan designation: Right-of-Way (residential on both sides of Torrey Pines Rd.)
7. Zoning: Right-of-Way (residential zoning on both sides of Torrey Pines Rd.)
8. Description of project (Describe the whole action involved, including but not limited to, later phases of the project, and any secondary, support, or off-site features necessary for its implementation.):

CITY COUNCIL APPROVAL to allow for the replacement of damaged, settling sidewalks, curbs and gutters through construction of new and replacement sidewalks, curb ramps, cross gutters, Americans with Disabilities Act (ADA)-compliant driveways and relocation of sidewalk obstructions (street lights, traffic signals and utility facilities). All work will be entirely within the public right-of-way along Torrey Pines Road from Prospect Place to La Jolla Shores Drive (as further illustrated in Figures 2-5).

Sidewalk/Curb & Gutter Replacement: Approximately 2,000 square feet of sidewalk will be replaced due to damage or settling along Torrey Pines Road. Existing dry utilities and water meters affected will either be adjusted to meet grade or relocated. Approximately 50 linear feet of new curb and gutter will replace damaged curb and an unused driveway.

New Sidewalk: Approximately 1,800 square feet of new sidewalk will be installed from Roseland Drive to Calle Juela. Gravity retaining walls with a maximum height of 2' are required to provide enough spacing to construct the new sidewalks. Existing dry utilities and water meters affected will either be adjusted to meet grade or relocated. Existing trees and vegetation will be cut back to provide enough clearance for pedestrians using the path.

Curb Ramps: The project proposes 21 new curb ramps at the intersections along the corridor in order to provide safe access to the proposed walkways. Several of the new ramps require the removal of landscape in order to create the space necessary to build. Two curb ramps have been relocated and will require approximately 28 linear feet of new curb and gutter and sidewalk to replace the existing ramp locations. At the porkchop at the intersection of Torrey Pines and La Jolla Shores, a minor traffic signal and pedestrian signal pole are to be relocated to accommodate new ramps.

Driveway: Six existing driveways will be upgraded to become ADA compliant residential driveways. In order to create a flatter, accessible path, the new driveways will require a sawcut further up the driveway in order to meet the existing grade.

Cross Gutters: Two cross gutters are proposed to upgrade the drainage runoff at the intersections of Torrey Pines Road and Little Street and Torrey Pines Road and Calle Juela. The cross gutter at Torrey Pines Road and Calle Juela is located on a steep grade and will require the removal and replacement of AC pavement along Calle Juela in order to meet the new asphalt grade.

Utility Relocations: The new improvements create the need to relocate several utilities. Four steel street lights (which require a 5'1" depth for base foundation) are to be relocated behind the sidewalk. Large utility boxes at the intersection of Torrey Pines and Coast Walk will be relocated outside the sidewalk.

9. Surrounding land uses and setting: Briefly describe the project's surroundings: The surrounding land uses are predominantly residential (single and multiple dwelling units).
10. Other public agencies whose approval is required (e.g., permits, financing approval, or participation agreement.): None

ENVIRONMENTAL FACTORS POTENTIALLY AFFECTED:

The environmental factors checked below would be potentially affected by this project, involving at least one impact that is a "Potentially Significant Impact" as indicated by the checklist on the following pages.

- | | | |
|---|--|---|
| <input type="checkbox"/> Aesthetics | <input type="checkbox"/> Greenhouse Gas Emissions | <input type="checkbox"/> Population/Housing |
| <input type="checkbox"/> Agriculture and Forestry Resources | <input type="checkbox"/> Hazards & Hazardous Materials | <input type="checkbox"/> Public Services |
| <input type="checkbox"/> Air Quality | <input type="checkbox"/> Hydrology/Water Quality | <input type="checkbox"/> Recreation |
| <input type="checkbox"/> Biological Resources | <input type="checkbox"/> Land Use/Planning | <input type="checkbox"/> Transportation/Traffic |
| <input checked="" type="checkbox"/> Cultural Resources | <input type="checkbox"/> Mineral Resources | <input type="checkbox"/> Utilities/Service System |
| <input type="checkbox"/> Geology/Soils | <input type="checkbox"/> Noise | <input checked="" type="checkbox"/> Mandatory Findings Significance |

DETERMINATION: (To be completed by Lead Agency)

On the basis of this initial evaluation:

- The proposed project **COULD NOT** have a significant effect on the environment, and a **NEGATIVE DECLARATION** will be prepared.
- Although the proposed project could have a significant effect on the environment, there will not be a significant effect in this case because revisions in the project have been made by or agreed to by the project proponent. A **MITIGATED NEGATIVE DECLARATION** will be prepared.
- The proposed project **MAY** have a significant effect on the environment, and an **ENVIRONMENTAL IMPACT REPORT** is required.
- The proposed project **MAY** have a "potentially significant impact" or "potentially significant unless mitigated" impact on the environment, but at least one effect (a) has been adequately analyzed in an earlier document pursuant to applicable legal standards, and (b) has been addressed by mitigation measures based on the earlier analysis as described on attached sheets. An **ENVIRONMENTAL IMPACT REPORT** is required.
- Although the proposed project could have a significant effect on the environment, because all potentially significant effects (a) have been analyzed adequately in an earlier EIR or (MITIGATED) **NEGATIVE DECLARATION** pursuant to applicable standards, and (b) have been avoided or mitigated pursuant to that earlier EIR or (MITIGATED) **NEGATIVE**

DECLARATION, including revisions or mitigation measures that are imposed upon the proposed project, nothing further is required.

Issue	Potentially Significant Impact	Less Than Significant with Mitigation Incorporated	Less Than Significant Impact	No Impact
-------	--------------------------------	--	------------------------------	-----------

I) AESTHETICS – Would the project:

- a) Have a substantial adverse effect on a scenic vista?

The La Jolla Community Plan indicates that the project Area of Potential Affect (APE) includes public views of the coast along Torrey Pines Road between Prospect Place and La Jolla Shores Road with the following keys areas identified: views over private property from the public right-of-way (ROW) at Princess Street; intermittent or partial vistas; public open space on Torrey Pines Road between St. Louis Terrace and Calle de la Plata; and a viewshed at Coast Walk looking towards La Jolla Shores. Although the project involves mainly pedestrian-related sidewalk improvements to the existing public right-of-way (ROW) which would not affect views, several streetlights will be relocated which would enhance the visual character of the area. Therefore, the project would not substantially affect a scenic vista, public view or viewshed as defined in the community plan since the majority of work would be located within the public right of way and would not block views once constructed.

- b) Substantially damage scenic resources, including but not limited to, trees, rock outcroppings, and historic buildings within a state scenic highway?

As stated in I.a., the project would be located below grade and would not adversely affect the visual resources within the APE. No scenic resources such as trees, rock outcroppings or historic buildings within a scenic highway have been identified within the APE which would be affected by the project. Therefore the project would not damage scenic resources.

- c) Substantially degrade the existing visual character or quality of the site and its surroundings?

Although the project involves mainly pedestrian-related sidewalk improvements to the existing public right-of-way (ROW) which would not affect views, several streetlights will be relocated which would enhance the visual character of the area. Therefore, the project would not

Issue	Potentially Significant Impact	Less Than Significant with Mitigation Incorporated	Less Than Significant Impact	No Impact
-------	--------------------------------	--	------------------------------	-----------

substantially affect a scenic vista, public view or viewshed as defined in the community plan since the majority of work would be located within the public right of way and would not block views once constructed. Please see I. a and b.

- d) Create a new source of substantial light or glare that would adversely affect day or nighttime views in the area?

<input type="checkbox"/>	<input type="checkbox"/>	<input type="checkbox"/>	<input checked="" type="checkbox"/>
--------------------------	--------------------------	--------------------------	-------------------------------------

The project involves mainly pedestrian-related sidewalk improvements within the existing public right-of-way (ROW) and would not have the potential to create light or glare impacts.

II) AGRICULTURAL AND FOREST RESOURCES: In determining whether impacts to agricultural resources are significant environmental effects, lead agencies may refer to the California Agricultural Land Evaluation and Site Assessment Model (1997) prepared by the California Department of Conservation as an optional model to use in assessing impacts on agriculture and farmland. In determining whether impacts to forest resources, including timberland, are significant environmental effects, lead agencies may refer to information compiled by the California Department of Forestry and Fire Protection regarding the state's inventory of forest land, including the Forest and Range Assessment Project and the Forest Legacy Assessment project; and forest carbon measurement methodology provided in Forest Protocols adopted by the California Air Resources Board. – Would the project:

- a) Convert Prime Farmland, Unique Farmland, or Farmland of

<input type="checkbox"/>	<input type="checkbox"/>	<input type="checkbox"/>	<input checked="" type="checkbox"/>
--------------------------	--------------------------	--------------------------	-------------------------------------

Issue	Potentially Significant Impact	Less Than Significant with Mitigation Incorporated	Less Than Significant Impact	No Impact
-------	--------------------------------	--	------------------------------	-----------

Statewide Importance (Farmland), as shown on the maps prepared pursuant to the Farmland Mapping and Monitoring Program of the California Resources Agency, to non-agricultural use?

The project is located within the developed public right of way and is not classified as farmland by the Farmland Mapping and Monitoring Program (FMMP). Similarly, lands surrounding the project are not in agricultural production and are not classified as farmland by the FMMP. Therefore, the project would not convert farmland to non-agricultural uses.

- | | | | | |
|--|--------------------------|--------------------------|--------------------------|-------------------------------------|
| b) Conflict with existing zoning for agricultural use, or a Williamson Act Contract? | <input type="checkbox"/> | <input type="checkbox"/> | <input type="checkbox"/> | <input checked="" type="checkbox"/> |
|--|--------------------------|--------------------------|--------------------------|-------------------------------------|

Please see II.a

- | | | | | |
|---|--------------------------|--------------------------|--------------------------|-------------------------------------|
| c) Conflict with existing zoning for, or cause rezoning of, forest land (as defined in Public Resources Code section 1220(g)), timberland (as defined by Public Resources Code section 4526), or timberland zoned Timberland Production (as defined by Government Code section 51104(g))? | <input type="checkbox"/> | <input type="checkbox"/> | <input type="checkbox"/> | <input checked="" type="checkbox"/> |
|---|--------------------------|--------------------------|--------------------------|-------------------------------------|

The public right of way and land surrounding the project is not zoned as forest land. Therefore, the sidewalk improvement project would not conflict with existing zoning for forest land.

- | | | | | |
|--|--------------------------|--------------------------|--------------------------|-------------------------------------|
| d) Result in the loss of forest land or conversion of forest land to non-forest use? | <input type="checkbox"/> | <input type="checkbox"/> | <input type="checkbox"/> | <input checked="" type="checkbox"/> |
|--|--------------------------|--------------------------|--------------------------|-------------------------------------|

The sidewalk improvement project is located within the developed public right of way and the land surrounding the project is not designated forest land. Therefore, the project would not convert forest land to non-forest use.

- | | | | | |
|---|--------------------------|--------------------------|--------------------------|-------------------------------------|
| e) Involve other changes in the existing environment, which, due to their location or nature, could | <input type="checkbox"/> | <input type="checkbox"/> | <input type="checkbox"/> | <input checked="" type="checkbox"/> |
|---|--------------------------|--------------------------|--------------------------|-------------------------------------|

Issue	Potentially Significant Impact	Less Than Significant with Mitigation Incorporated	Less Than Significant Impact	No Impact
result in conversion of Farmland to non-agricultural use or conversion of forest land to non-forest use?				

No existing agricultural uses are located in proximity to the underground utility district that could be affected by the project. Therefore, the project would not convert farmland to non-agricultural uses.

III. AIR QUALITY – Where available, the significance criteria established by the applicable air quality management or air pollution control district may be relied on to make the following determinations - Would the project:

- a) Conflict with or obstruct implementation of the applicable air quality plan?

Construction of the sidewalk improvement project could increase the amount of harmful pollutants entering the air basin. However, construction emissions would be temporary. In addition, construction Best Management Practices (BMPs), such as watering for dust abatement, would reduce construction dust emissions by 75 percent. The project would not directly generate additional trips to these facilities. With the implementation of project BMPs during construction and the lack of operational emissions the project would not result in a conflict with any air quality plans.

- b) Violate any air quality standard or contribute substantially to an existing or projected air quality violation?

Please see III a

- c) Result in a cumulatively considerable net increase of any criteria pollutant for which the project region is non-attainment under an applicable federal or state ambient air quality standard (including releasing emissions which

Issue	Potentially Significant Impact	Less Than Significant with Mitigation Incorporated	Less Than Significant Impact	No Impact
exceed quantitative thresholds for ozone precursors)?				

As described above, construction operations could temporarily increase the emissions of dust and other pollutants. However, construction emissions would be temporary and it is anticipated that implementation of BMPs would reduce potential impacts related to construction activities to a level to less than significant. Therefore, the project would not result in a cumulatively considerable net increase of any criteria pollutant for which the project region is non-attainment under applicable federal or state ambient air quality standards.

- d) Expose sensitive receptors to substantial pollutant concentrations?

Construction operations could temporarily increase the emissions of harmful pollutants, which could affect sensitive receptors adjacent to the project. However, construction emissions would be temporary and it is anticipated that implementation of construction BMPs would reduce potential impacts related to construction activities to minimal levels. Therefore, the project would not expose sensitive receptors to substantial pollutant concentrations.

- e) Create objectionable odors affecting a substantial number of people?

Operation of construction equipment and vehicles could generate odors associated with fuel combustion. However, these odors would dissipate into the atmosphere upon release and would only remain in proximity to the construction equipment and vehicles temporarily. Therefore, the project would not create substantial amounts of objectionable odors affecting a substantial number of people.

IV. BIOLOGICAL RESOURCES –
Would the project:

- a) Have substantial adverse effects, either directly or through habitat modifications, on any species identified as a candidate, sensitive, or special status species in local or regional plans, policies, or regulations, or by the California Department of Fish and Game or U.S. Fish and

Issue	Potentially Significant Impact	Less Than Significant with Mitigation Incorporated	Less Than Significant Impact	No Impact
-------	--------------------------------	--	------------------------------	-----------

Wildlife Service?

The sidewalk improvement project is located in an urban setting, entirely within the developed public right of way, and does not have the potential to impact sensitive species listed in regional plans, policies or regulations.

- b) Have a substantial adverse effect on any riparian habitat or other community identified in local or regional plans, policies, and regulations or by the California Department of Fish and Game or U.S. Fish and Wildlife Service?
- | | | | | |
|--|--------------------------|--------------------------|--------------------------|-------------------------------------|
| | <input type="checkbox"/> | <input type="checkbox"/> | <input type="checkbox"/> | <input checked="" type="checkbox"/> |
|--|--------------------------|--------------------------|--------------------------|-------------------------------------|

No sensitive habitats exist on-site or within close proximity to the sidewalk improvement project. Also see IV. a.

- c) Have a substantial adverse effect on federally protected wetlands as defined by Section 404 of the Clean Water Act (including but not limited to marsh, vernal pool, coastal, etc.) through direct removal, filling, hydrological interruption, or other means?
- | | | | | |
|--|--------------------------|--------------------------|--------------------------|-------------------------------------|
| | <input type="checkbox"/> | <input type="checkbox"/> | <input type="checkbox"/> | <input checked="" type="checkbox"/> |
|--|--------------------------|--------------------------|--------------------------|-------------------------------------|

The sidewalk improvement project is located in the developed public right of way and wetlands are not located within or adjacent to the project APE. Therefore, the project does not have the potential to impact these resources.

- d) Interfere substantially with the movement of any native resident or migratory fish or wildlife species or with established native resident or migratory wildlife corridors, or impede the use of native wildlife nursery sites?
- | | | | | |
|--|--------------------------|--------------------------|--------------------------|-------------------------------------|
| | <input type="checkbox"/> | <input type="checkbox"/> | <input type="checkbox"/> | <input checked="" type="checkbox"/> |
|--|--------------------------|--------------------------|--------------------------|-------------------------------------|

The sidewalk improvement project would not result in adverse impacts on wildlife movement in the project area. As mentioned above this project is located in the developed public right of way

Issue	Potentially Significant Impact	Less Than Significant with Mitigation Incorporated	Less Than Significant Impact	No Impact
-------	--------------------------------	--	------------------------------	-----------

and does not contain wildlife corridors.

- | | | | | |
|---|--------------------------|--------------------------|--------------------------|-------------------------------------|
| e) Conflict with any local policies or ordinances protecting biological resources, such as a tree preservation policy or ordinance? | <input type="checkbox"/> | <input type="checkbox"/> | <input type="checkbox"/> | <input checked="" type="checkbox"/> |
|---|--------------------------|--------------------------|--------------------------|-------------------------------------|

The sidewalk improvement project would not conflict with any local policies or ordinances protecting biological resources, such as a tree preservation policy or ordinance. The project area lacks any sensitive biological resources and would not require the removal of any unique or sensitive trees. No impact would occur.

- | | | | | |
|--|--------------------------|--------------------------|--------------------------|-------------------------------------|
| f) Conflict with the provisions of an adopted Habitat Conservation Plan, Natural Community Conservation Plan, or other approved local, regional, or state habitat conservation plan? | <input type="checkbox"/> | <input type="checkbox"/> | <input type="checkbox"/> | <input checked="" type="checkbox"/> |
|--|--------------------------|--------------------------|--------------------------|-------------------------------------|

The sidewalk improvement project is not located within or adjacent to the City's MHPA and no conflicts with conservation plans would occur.

V. CULTURAL RESOURCES – Would the project:

- | | | | | |
|---|--------------------------|-------------------------------------|--------------------------|--------------------------|
| a) Cause a substantial adverse change in the significance of an historical resource as defined in §15064.5? | <input type="checkbox"/> | <input checked="" type="checkbox"/> | <input type="checkbox"/> | <input type="checkbox"/> |
|---|--------------------------|-------------------------------------|--------------------------|--------------------------|

The purpose and intent of the *Historical Resources Regulations of the Land Development Code (Chapter 14, Division 3, and Article 2)* is to protect, preserve and, where damaged, restore the historical resources of San Diego. The regulations apply to all proposed development within the City of San Diego when historical resources are present on the premises. CEQA requires that before approving discretionary projects, the Lead Agency must identify and examine the significant adverse environmental effects, which may result from that project. A project that may cause a substantial adverse change in the significance of a historical resource may have a significant effect on the environment (Sections 15064.5(b) and 21084.1). A substantial adverse change is defined as demolition, destruction, relocation, or alteration activities, which would impair historical significance (Sections 15064.5(b)(1)). Any historical resource listed in, or eligible to be listed in the California Register of Historical Resources, including archaeological resources, is considered to be historically or culturally significant.

Issue	Potentially Significant Impact	Less Than Significant with Mitigation Incorporated	Less Than Significant Impact	No Impact
-------	--------------------------------	--	------------------------------	-----------

The sidewalk improvement project is located within and immediately adjacent to an area known to contain significant resources of the Spindrift Archaeological Site (CA-SDI-39/SDM-W-1), a previously recorded prehistoric occupation complex spanning the Early Archaic to the Late Prehistoric cultural periods. The Spindrift Site has been determined to be significant according to CEQA and City criteria. An important element of the significance of the Spindrift site is the numerous human burials discovered and the abundance of human bone encountered in graded lots and streets within this neighborhood. Site SDI-39 has been identified as an important, significant site since it was first recorded by Welty in 1912, when he noted that the site stretched for as long as 1,000 feet along the shore and up to 1,200 feet inland. He noted depths from one to eight feet, a dense black midden, shell, charcoal, and fragments of human remains.

Archaeological work by Malcolm Rogers in 1931 gave SDI-39 its name, the "Spindrift Site," after the street name. In a joint effort, the San Diego/Smithsonian Project in 1931 sought to uncover the origins of human occupation of the west coast. As a result of this project, Rogers excavated a series of sites throughout La Jolla (Rogers 1929). Although these studies were conducted at a time when La Jolla was undergoing development for homes, much of Rogers work was prior to the massive impacts to cultural resources that occurred in San Diego after World War II. Rogers' site record of SDI-39 indicated the site covered 20 acres, noting a range of occupation materials from cobble hearths to whale bone hypothesized for use as housing materials. Over the next several years, Rogers excavated an estimated 40 cubic feet of soil across three areas of Spindrift Drive. His excavations uncovered human remains and large amounts of prehistoric materials. During this time, Rogers' work identified intact strata from the earliest to the latest periods of occupation at SDI-39. As a result of his studies, Rogers divided the cultural deposit into three distinct layers of occupation, with the earliest (Stratum 1) composed of invertebrate faunal remains, milling equipment, lithic tools, fire-cracked rock, and charcoal. Although the next Stratum (2) contained a lower frequency of cultural materials, the majority of inhumations were identified from this deposit. The last Stratum (3) was considered the most dense and contained ceramics, cremations, and large amounts of other late prehistoric cultural materials. Rogers' trenching studies, according to Pigniolo and Brodie (2009), were located directly north of both project sites. A portion of his profile studies may have actually crossed the western slope of the current project area.

Additional studies have been conducted in the Spindrift area including work by Dr. James Moriarty, III in 1961 at the Oliver Gill Lot. Since Moriarty's work in 1961, several limited test excavations have taken place across portions of SDI-39. Examples of these limited excavations include Berryman and Roth (1993), Wade (1998), Gross and Robbins-Wade (1999), Case et al. (2003), and Rosenberg and Smith (2006). Although each of these excavations has added data to the greater understanding of SDI-39, the necessary scale of their investigations and previous impacts to the site has limited their scopes. However, each of these excavations identified buried portions of SDI-39, disturbed or otherwise, during their investigations. Based on these investigations, the deposit can extend from one to 1.5 meters in depth, and contains a variety of marine shell, lithic materials, faunal bone, ceramics, milling tools, and potentially human remains

Issue	Potentially Significant Impact	Less Than Significant with Mitigation Incorporated	Less Than Significant Impact	No Impact
-------	--------------------------------	--	------------------------------	-----------

(Stropes and Smith 2009). The early documentation, large quantity, and wide range of materials identified for SDI-39 clearly indicates that the site served a habitation function. To date, radiocarbon analysis from the site has been limited to only identifying the Late Prehistoric Period component (Gross and Wade 1999; Berryman and Roth 1993). Despite this, previous studies clearly indicate the presence of a large archaic component that has yet to be ratified through conventional C-14 methods.

Although the entire project APE is fully developed and covered by asphalt and concrete and portions of the project are within the Spindrift Archaeological Site Boundary, a field survey was conducted by LSA Associates, Inc., which did not result in the identification of any cultural materials on the surface. This was likely due to the extensive amount of disturbance, grading and filling associated with the original construction of Torrey Pines Road including sidewalks, infrastructure and appurtenances, making an assessment of condition difficult. As such, Qualified City staff reviewed all available information about the site and the project scope and determined in consultation with the Project Archaeologist and Native American representative that archaeological testing would not be required. Archaeological testing would otherwise have been required to determine if a subsurface component of the Spindrift Site remains in this area. Therefore, as further described in the report prepared in compliance with the City’s Historical Resources Guidelines by LSA Associates, Inc., “*Cultural Resources Constraints Analysis, Torrey Pines Road Improvements Phase I, November 2013*” specific recommendations were made by the consulting archaeologist to hand excavate the areas where one fire hydrant and one streetlight would be relocated prior to the start of any ground disturbing activities associated with the project. The report also recommends that in addition to the regular monitoring program, three specific areas (along Torrey Pines Road at Coast Walk, Little Street and Roseland Drive) have full time archaeological and Native American monitoring. Qualified staff concurs with these recommendations and have incorporated them into the Mitigation, Monitoring and reporting Program included in Section V of the draft MND.

The project has the potential to result in direct impacts to archaeological resources associated with CA-SDI-39/SDM-W-1, while limited in area, the additive cumulative impacts to this cultural resource could be significant. Mitigation through controlled hand excavation at the two locations noted below (1 & 2) and full-time archaeological and Native American monitoring at the locations noted below (3-5) will serve to mitigate potential impacts to below a level of significance:

- 1) Princess Street (St #31+90) - Streetlight Relocation**
- 2) Little Street (St #43+25) - New Fire Hydrant**
- 3) Coast Walk (St #22+00)**
- 4) Little Street (St #47+20)**
- 5) Roseland Drive (St #50+00)**

Issue	Potentially Significant Impact	Less Than Significant with Mitigation Incorporated	Less Than Significant Impact	No Impact
-------	--------------------------------	--	------------------------------	-----------

Appropriate treatment of any human remains encountered during the mitigation program or other construction-related activities must be accomplished in accordance with the California Public Resources Code (Section 5097.8) and the Health and Safety Code (Section 7050.5) in consultation with the Most Likely Descendant, as indicated by the Native American Heritage Commission.

Implementation of the Archaeological Mitigation Program and construction monitoring would reduce impacts to Historical Resources to below a level of significance and therefore the project would not result in an adverse change in the significance of an historical resource as defined in §15064.5.

- | | | | | |
|---|--------------------------|-------------------------------------|--------------------------|--------------------------|
| b) Cause a substantial adverse change in the significance of an archaeological resource pursuant to §15064.5? | <input type="checkbox"/> | <input checked="" type="checkbox"/> | <input type="checkbox"/> | <input type="checkbox"/> |
|---|--------------------------|-------------------------------------|--------------------------|--------------------------|

See V. a.

- | | | | | |
|---|--------------------------|--------------------------|--------------------------|-------------------------------------|
| c) Directly or indirectly destroy a unique paleontological resource or site or unique geologic feature? | <input type="checkbox"/> | <input type="checkbox"/> | <input type="checkbox"/> | <input checked="" type="checkbox"/> |
|---|--------------------------|--------------------------|--------------------------|-------------------------------------|

Current project plans do not call for excavation depths that exceed the City of San Diego's CEQA Significance thresholds. Therefore no impact would occur to paleontological or unique geologic resources and no mitigation for this resource is required.

- | | | | | |
|--|--------------------------|-------------------------------------|--------------------------|--------------------------|
| d) Disturb and human remains, including those interred outside of formal cemeteries? | <input type="checkbox"/> | <input checked="" type="checkbox"/> | <input type="checkbox"/> | <input type="checkbox"/> |
|--|--------------------------|-------------------------------------|--------------------------|--------------------------|

Issue	Potentially Significant Impact	Less Than Significant with Mitigation Incorporated	Less Than Significant Impact	No Impact
-------	--------------------------------	--	------------------------------	-----------

Please see V.a. Although archaeological testing was not conducted for the project, based on review of archival research for previous archaeological work in this area, there is a potential for human remains to be encountered during any construction-related activities for the project. In addition, the Native American observer expressed concerns relating to the likelihood of remains to exist throughout the project area and the continued proper treatment of remains was requested.

The project requires implementation of an Archaeological Mitigation Program as well as archaeological monitoring. Section. C of the MND which includes contingencies for the discovery of human remains which requires the consulting archaeologist to involk in accordance with the California Public Resources Code and the Health and Safety Code. In the event that human remains are encountered during the mitigation program, no soil shall be exported from the project site until it has been cleared by the Most Likely Descendant (MLD) and the Project Archaeologist.

The archaeological mitigation program has been developed in consultation with the Native American observer/monitor and will be implemented prior to and during construction activities to assure that any Native American cultural impacts will be reduced to below a level of significance and will satisfy the requirements for feasible measures incorporated into the project to address potential impacts to historical, archaeological and Native American resources.

VI. GEOLOGY AND SOILS – Would the project:

- a) Expose people or structures to potential substantial adverse effects, including the risk of loss, injury, or death involving:
 - i) Rupture of a known earthquake fault, as delineated on the most recent Alquist-Priolo Earthquake Fault Zoning Map issued by the State Geologist for the area or based on other substantial evidence of a known fault? Refer to Division of Mines and Geology Special Publication 42.

<input type="checkbox"/>	<input type="checkbox"/>	<input type="checkbox"/>	<input checked="" type="checkbox"/>
--------------------------	--------------------------	--------------------------	-------------------------------------

A portion of the project APE is located in proximity to faults. However, the project would be required to utilize proper engineering design and standard construction practices which would ensure that the potential for impacts from regional geologic hazards would be less than

Issue	Potentially Significant Impact	Less Than Significant with Mitigation Incorporated	Less Than Significant Impact	No Impact
-------	--------------------------------	--	------------------------------	-----------

significant. Therefore, no impact from the rupture of a known earthquake fault would occur.

- | | | | | |
|------------------------------------|--------------------------|--------------------------|--------------------------|-------------------------------------|
| ii) Strong seismic ground shaking? | <input type="checkbox"/> | <input type="checkbox"/> | <input type="checkbox"/> | <input checked="" type="checkbox"/> |
|------------------------------------|--------------------------|--------------------------|--------------------------|-------------------------------------|

The sidewalk improvement project would not expose people or structures to potential substantial adverse effects, including the risk of loss, injury, or death involving strong seismic ground shaking. The project has been designed to address factors associated with ground shaking and incorporates standard construction practices to address this issue. Therefore, there would be no impact.

- | | | | | |
|--|--------------------------|--------------------------|--------------------------|-------------------------------------|
| iii) Seismic-related ground failure, including liquefaction? | <input type="checkbox"/> | <input type="checkbox"/> | <input type="checkbox"/> | <input checked="" type="checkbox"/> |
|--|--------------------------|--------------------------|--------------------------|-------------------------------------|

The sidewalk improvement project has been designed to address factors associated with seismic-related failure including liquefaction and incorporates standard construction practices to address this issue. Therefore, no impact from liquefaction would result.

- | | | | | |
|-----------------|--------------------------|--------------------------|--------------------------|-------------------------------------|
| iv) Landslides? | <input type="checkbox"/> | <input type="checkbox"/> | <input type="checkbox"/> | <input checked="" type="checkbox"/> |
|-----------------|--------------------------|--------------------------|--------------------------|-------------------------------------|

The project would not expose people or structures to the risk of loss, injury, or death involving landslides. The project would utilize proper engineering design and utilization of standard construction practices. Therefore, there would be no impact.

- | | | | | |
|---|--------------------------|--------------------------|--------------------------|-------------------------------------|
| b) Result in substantial soil erosion or the loss of topsoil? | <input type="checkbox"/> | <input type="checkbox"/> | <input type="checkbox"/> | <input checked="" type="checkbox"/> |
|---|--------------------------|--------------------------|--------------------------|-------------------------------------|

Construction of the project would take place within the developed public right of way and all disturbances to existing infrastructure would be replaced in kind. Therefore no impact from soil erosion or loss of topsoil would occur.

- | | | | | |
|--|--------------------------|--------------------------|--------------------------|-------------------------------------|
| c) Be located on a geologic unit or soil that is unstable, or that would become unstable as a result of the project, and potentially result in on- or off-site landslide, lateral spreading, subsidence, liquefaction or collapse? | <input type="checkbox"/> | <input type="checkbox"/> | <input type="checkbox"/> | <input checked="" type="checkbox"/> |
|--|--------------------------|--------------------------|--------------------------|-------------------------------------|

According to the USDA Soil Survey maps, the sidewalk improvement project is located in an area which is primarily underlain by Corralitos Loamy Sand (0-5 and 5-9 % slopes) which is not considered an expansive soil. This soil is defined as having no, or minimal limitations for related

Issue	Potentially Significant Impact	Less Than Significant with Mitigation Incorporated	Less Than Significant Impact	No Impact
-------	--------------------------------	--	------------------------------	-----------

public improvement development activity. The project area also consists of Altamont Clay which consists of well-drained clays that formed in material weathered from calcareous shale. The project would utilize proper engineering design and standard construction practices. There would be no impact associated with unstable soil or geologic unit within the APE.

- d) Be located on expansive soil, as defined in Table 18-1-B of the Uniform Building Code (1994), creating substantial risks to life or property?
- | | | | | |
|--|--------------------------|--------------------------|--------------------------|-------------------------------------|
| | <input type="checkbox"/> | <input type="checkbox"/> | <input type="checkbox"/> | <input checked="" type="checkbox"/> |
|--|--------------------------|--------------------------|--------------------------|-------------------------------------|

According to the USDA Soil Survey maps, the underground utility project is located in an area which is primarily underlain by Corralitos Loamy Sand (0-5 and 5-9 % slopes) which is not considered an expansive soil. This soil is defined as having no, or minimal limitations for related public improvement development activity. The project area also consists of Altamont Clay which consists of well-drained clays that formed in material weathered from calcareous shale. Furthermore, the project would utilize proper engineering design and standard construction practices to ensure that the potential for impacts would not occur.

- e) Have soils incapable of adequately supporting the use of septic tanks or alternative waste water disposal systems where sewers are not available for the disposal of waste water?
- | | | | | |
|--|--------------------------|--------------------------|--------------------------|-------------------------------------|
| | <input type="checkbox"/> | <input type="checkbox"/> | <input type="checkbox"/> | <input checked="" type="checkbox"/> |
|--|--------------------------|--------------------------|--------------------------|-------------------------------------|

Septic tanks or alternative wastewater systems would not be used. Therefore, no impact with regard to the capability of soils to adequately support the use of septic tanks or alternative wastewater disposal systems would result.

VII. GREENHOUSE GAS EMISSIONS

– Would the project:

- a) Generate greenhouse gas emissions, either directly or indirectly, that may have a significant impact on the environment?
- | | | | | |
|--|--------------------------|--------------------------|-------------------------------------|--------------------------|
| | <input type="checkbox"/> | <input type="checkbox"/> | <input checked="" type="checkbox"/> | <input type="checkbox"/> |
|--|--------------------------|--------------------------|-------------------------------------|--------------------------|

The City of San Diego is utilizing the California Air Pollution Control Officers Association (CAPCOA) report "CEQA and Climate Change" (CAPCOA 2008) to determine whether a GHG analysis would be required for submitted projects. The CAPCOA report references a 900 metric ton guideline as a conservative threshold for requiring further analysis and possible mitigation. This emission level is based on the amount of vehicle trips, the typical energy and water use associated with projects, and other factors.

CAPCOA identifies project types that are estimated to emit approximately 900 metric tons of GHG's annually. This 900 metric ton threshold is roughly equivalent to 36,000 square feet of office space, 11,000 square feet of retail, 50 residential units, and 6,300 square feet of supermarkets. Since the undergrounding projects being considered in this CEQA document do not fit the categories listed above each project conducted an independent modeling analysis to determine the level of GHG emissions from the respective projects. The Roadway Construction Emissions Model is a spreadsheet program created by the Sacramento Metropolitan Air Quality Management District to analyze construction related GHGs (i.e. Carbon Dioxide) and was utilized to quantify the projects' GHG emissions. The model utilizes project information (e.g. total construction months, project type and total project area) to quantify GHG emissions from heavy-duty construction equipment, haul trucks, and worker commute trips associated with linear construction projects. The output of the model is carbon dioxide (CO2) which is the major contributor of GHGs.

Because this project involves mainly sidewalk improvements including curb, gutters, pedestrian ramps, relocated streetlights and a new fire hydrant, it will not result in an increase in vehicular traffic as measured in average daily trips (ADT), energy consumption, or water usage. Therefore, operational emissions resulting in direct, indirect, or cumulative Greenhouse Gas (GHG) impacts are not generated. However, this project would result in construction-related emissions which would occur during the duration of project implementation would be estimated to fall below the DSD-established interim threshold of 900 metric tons per project per year. Therefore, the project would not result in a significant CEQA Greenhouse gas impact and mitigation would not be required.

- b) Conflict with an applicable plan, policy, or regulation adopted for the purpose of reducing the emissions of greenhouse gases?

Please see VII.a. It is anticipated that the sidewalk improvement project would not conflict with any applicable plans, policies, or regulations related to greenhouse gases. There is no impact.

VIII. HAZARDS AND HAZARDOUS MATERIALS – Would the project:

- a) Create a significant hazard to the public or the environment through routine transport, use, or disposal of hazardous materials?

Construction of the project may require the use of hazardous materials (fuels, lubricants, solvents, etc.), which would require proper storage, handling, use and disposal; however, the project would not routinely transport, use or dispose of hazardous materials. In addition, construction standards would be implemented in the event of an unanticipated discovery to meet local, state, and federal standards. Therefore, the project would not create a significant hazard to the public or environment.

- b) Create a significant hazard to the public or the environment through reasonably foreseeable upset and accident conditions involving the release of hazardous materials into the environment?

The project alignment is not located on, or within 1,000 feet from properties which contain Leaking Underground Storage Tank (LUST) cleanup sites and permitted USTs, and other cleanup sites. However, in the event that such hazards are encountered, the contractor is responsible for implementing and specifications for construction to meet the local, state and federal requirements to address hazardous materials should they be encountered during construction. Impacts would remain less than significant.

- c) Emit hazardous emissions or handle hazardous or acutely hazardous materials, substances, or waste within one-quarter mile of an existing or proposed school?

No schools are located within a quarter mile of the project that would be directly affected by hazardous emissions that could be released if encountered during construction activities within the project right-of-way. As noted in VIII.b, construction documents include specific protocols to be followed-pursuant to County requirements-should any hazardous conditions be encountered. Impacts would remain less than significant.

- d) Be located on a site which is included on a list of hazardous materials sites compiled pursuant to Government Code Section 65962.5 and, as a result, would it create a significant hazard to the public or the environment?

The project location is not included on a list of hazardous materials sites compiled pursuant to Government Code Section 65962.5 and therefore, no additional measures are required beyond those incorporated in the contract specifications to address any contaminated soils encountered during construction related activities in accordance with local, state, and federal regulations.

- e) For a project located within an airport land use plan or, where such a plan has not been adopted, within two mile of a public airport or public use airport, would the project result in a safety hazard for people residing or working in the project area?

The project is not located within the boundaries of an existing airport land use plan or an airport land use plan pending adoption. Furthermore, the project is not located within the flight path and is located entirely within the existing PROW and therefore would not introduce any new features that would create a flight hazards.

- f) For a project within the vicinity of a private airstrip, would the project result in a safety hazard for people residing or working in the project area?

The project is not located within 2 miles of a private airstrip. Furthermore, the project is located entirely within the existing PROW and therefore would not result in a safety hazard that would create flight hazards.

- g) Impair implementation of or physically interfere with an adopted emergency response plan or emergency evacuation plan?

Construction of the project would temporarily affect traffic circulation within the projects' APE and adjoining roadways. However, an approved Traffic Control Plan would be implemented during construction which would allow emergency plans to be employed. Therefore, the project would not physically interfere with an adopted emergency response plan or emergency evacuation plan.

- h) Expose people or structures to a significant risk of loss, injury or death involving wildland fires, including where wildlands are adjacent to urbanized areas or where residences are intermixed with wildlands?

The project is located in the developed public right of way and land surrounding the APE does not contain wildlands that could pose a threat of wildland fires. Additionally, the project would not introduce any new features that would increase the risk of fire because they will be located within existing ROW.

IX. HYDROLOGY AND WATER QUALITY - Would the project:

- a) Violate any water quality standards or waste discharge requirements?

Potential impacts to existing water quality standards associated with the project would include minimal short-term construction-related erosion/sedimentation and no long term operational storm water discharge. Conformance to BMPs outlined in the pending WPCP and conformance with the City's Stormwater Regulations would prevent or effectively minimize short-term water quality impacts. Therefore, the project would not violate any existing water quality standards or discharge requirements.

- b) Substantially deplete groundwater supplies or interfere substantially with groundwater recharge such that there would be a net deficit in aquifer volume or a lowering of the local groundwater table level (e.g., the production rate of pre-existing nearby wells would drop to a level which would not support existing land uses or planned uses for which permits have been granted)?

The project does not propose the use of groundwater. Furthermore, the project would not introduce a substantially large amount of new impervious surfaces over ground that could interfere with groundwater recharge. Therefore, the project would not substantially deplete groundwater supplies or interfere substantially with groundwater recharge.

- c) Substantially alter the existing drainage pattern of the site or area, including through the alteration of the course of a stream or river, in a manner, which would result in substantial erosion or siltation on- or off-site?

The project is located entirely within the developed public right of way within paved streets and sidewalks. Upon completion of the project the streets and sidewalks would be returned to their preexisting conditions. Therefore the project would not substantially alter any existing drainage patterns.

- d) Substantially alter the existing drainage pattern of the site or area, including through the alteration of the course of a stream

or river, or substantially increase the rate or amount of surface runoff in a manner, which would result in flooding on- or off-site?

Please see IX c

- e) Create or contribute runoff water, which would exceed the capacity of existing or planned stormwater drainage systems or provide substantial additional sources of polluted runoff?

Conformance to BMPs outlined in the pending WPCP and compliance with the City Stormwater Regulations would prevent or effectively minimize short-term construction runoff impacts. Therefore, the project would not contribute runoff water that would exceed the capacity of existing storm water systems.

- f) Otherwise substantially degrade water quality?

Conformance to BMPs outlined in the pending WPCP to be prepared for the project and compliance with the City's Stormwater Regulations would prevent or effectively minimize short-term water quality impacts and would preclude impacts to water quality.

- g) Place housing within a 100-year flood hazard area as mapped on a federal Flood Hazard Boundary or Flood Insurance Rate Map or other flood hazard delineation map?

The project does not propose construction of any new housing.

- h) Place within a 100-year flood hazard area, structures that would impede or redirect flood flows?

The project is not located within the 100 year floodplain and would not have the potential to impede or redirect flood flows.

- i) Expose people or structures to a significant risk of loss, injury or death involving flooding, including flooding as a result of the failure of a levee or dam?

The project would not include any new features that would increase the risk associated with flooding beyond those of the existing conditions.

- j) Inundation by seiche, tsunami, or mudflow?

The project would not include any new project features that would increase the risk associated with seiche, tsunami, or mudflow beyond those of the existing conditions.

X. LAND USE AND PLANNING –

Would the project:

- a) Physically divide an established community?

Implementation of the project would involve replacing and installing utility infrastructure below ground and would not introduce any features that could divide an established community.

- b) Conflict with any applicable land use plan, policy, or regulation of an agency with jurisdiction over the project (including but not limited to the general plan, specific plan, local coastal program, or zoning ordinance) adopted for the purpose of avoiding or mitigating an environmental effect?

The sidewalk improvement project is consistent with the applicable policies identified in the La Jolla Community Plan, and has been reviewed for compliance with all applicable land use plans, the La Jolla Shores PDO, the City of San Diego Municipal Code, the La Jolla Community Plan and City of San Diego General Plan. No deviations from the development regulations have been requested by the applicant for these projects. The Project does not require a Coastal Development Permit or Site Development Permit in accordance with the provisions of the Land Development Code.

The project has been reviewed for compliance with the City’s Historical Resources Regulations; the project APE contains portions of an *Important Archaeological Site* as defined by the Land Development Code (LDC) and as such, was subject to review for compliance with the development regulations for *Important Archeological Site* in accordance with San Diego Municipal Code (SDMC) §143.0253. Although the project requires implementation of a Mitigation Monitoring and Reporting Program, a Site Development Permit is not required. Mitigation for direct impacts to archaeological resources as detailed in Section V of the Mitigated Negative Declaration (MND) would reduce direct impacts to archaeological resources to be low a level of significance.

- c) Conflict with any applicable habitat conservation plan or natural community conservation plan?

No habitat conservation areas exist within the project APE, which is within a developed urbanized neighborhood and therefore would not conflict with any habitat conservation plans or natural community conservation plan for the area or region as a whole.

XI. MINERAL RESOURCES – Would the project?

- a) Result in the loss of availability of a known mineral resource that would be of value to the region and the residents of the state?

The areas surrounding the project APE are not being used for the recovery of mineral resources. Similarly, these areas surrounding the proposed project site are not designated for the recovery of mineral resources on the City of San Diego General Plan Land Use Map. Therefore, the project would not result in the loss of availability of a known mineral resource.

- b) Result in the loss of availability of a locally important mineral resource recovery site delineated on a local general plan, specific plan or other land use plan?

The areas surrounding the project APE are not designated for the recovery of mineral resources on the City of San Diego General Plan Land Use Map. Therefore, the project would not result in the loss of availability of a locally important mineral resource recovery site.

XII. NOISE – Would the project result in:

- a) Exposure of persons to, or generation of, noise levels in excess of standards established in the local general plan or noise ordinance, or applicable standards of other agencies?

The development of the project would generate noise from construction, which would be temporary and transitory in nature. Therefore, people would not be exposed to noise levels in excess of any noise regulations.

- b) Exposure of persons to, or generation of, excessive ground borne vibration or ground borne

noise levels?

Please see XIIa

- c) A substantial permanent increase in ambient noise levels in the project vicinity above levels existing without the project?

Please see XIIa

- d) A substantial temporary or periodic increase in ambient noise levels in the project vicinity above existing without the project?

Construction of the project would result in a temporary increase in the ambient noise levels in the project APE. However, based upon the transitory nature of the underground utility project and surrounding noise levels in the area resulting from traffic along the streets, the increase in ambient noise would be less than significant.

- e) For a project located within an airport land use plan, or, where such a plan has not been adopted, within two miles of a public airport or public use airport would the project expose people residing or working in the area to excessive noise levels?

The project is not located within the boundaries of an existing airport land use plan or an airport land use plan pending adoption and would not introduce any new features that would expose people residing or working in the project area to excessive noise levels beyond those associated with the existing environment.

- f) For a project within the vicinity of a private airstrip, would the project expose people residing or working in the project area to excessive noise levels?

The project is not located within approximately 2 miles of a private airstrip and would not introduce any new features that would expose people residing or working in the project APE to excessive noise levels beyond those associated with existing conditions.

XIII. POPULATION AND HOUSING –

Would the project:

- a) Induce substantial population growth in an area, either directly

(for example, by proposing new homes and businesses) or indirectly (for example, through extension of roads or other infrastructure)?

The project would not extend any existing roadways into an undeveloped area or introduce any new roadways that could induce growth. Therefore, the project would not induce substantial population growth.

- b) Displace substantial numbers of existing housing, necessitating the construction of replacement housing elsewhere?

The project would underground overhead utilities and would not result in the displacement of any existing housing, or otherwise affect existing housing in any way that would necessitate the construction of replacement housing.

- c) Displace substantial numbers of people, necessitating the construction of replacement housing elsewhere?

The project would not result in the displacement of any existing housing, or otherwise affect existing housing in any way that would necessitate the construction of replacement housing.

XIV. PUBLIC SERVICES

- a) Would the project result in substantial adverse physical impacts associated with the provisions of new or physically altered governmental facilities, need for new or physically altered governmental facilities, the construction of which could cause significant environmental impacts, in order to maintain acceptable service rations, response times or other performance objectives for any of the public services:
- i) Fire Protection

The project would not physically alter any government facilities other than to install one new fire hydrant at Little Street (St# 43+25). The project would not require any new or altered fire protection services for the area; nor would it alter established response times for the area.

- ii) Police Protection

The project would not physically alter any police protection facilities. The project would not require any new or altered police protection services for the area nor would it alter established response times for the area.

iii) Schools

The project would not physically alter any schools. Additionally, the project would not include construction of future housing or induce growth that could increase demand for schools in the area.

v) Parks

The project would not physically alter any parks. Therefore, the project would not create demand for new parks or other recreational facilities in the area.

vi) Other public facilities

The project would not increase the demand for electricity, gas, or other public facilities in the area.

XV. RECREATION -

a) Would the project increase the use of existing neighborhood and regional parks or other recreational facilities such that substantial physical deterioration of the facility would occur or be accelerated?

Implementation of the project would not allow for improved access to existing recreation areas. The project would not directly generate additional trips to existing recreation areas or induce future growth that would result in additional trips to these facilities. Therefore, the project would not increase the use of existing recreational areas such that substantial physical deterioration of the facility would occur or be accelerated.

b) Does the project include recreational facilities or require the construction or expansion of recreational facilities, which might have an adverse physical effect on the environment?

The project does not include the construction of recreational facilities or require the construction or expansion of recreational facilities.

XVI. TRANSPORTATION/TRAFFIC -

Would the project?

a) Conflict with an applicable plan,

ordinance or policy establishing measures of effectiveness for the performance of the circulation system, taking into account all modes of transportation including mass transit and non-motorized travel and relevant components of the circulation system, including but not limited to intersections, streets, highways and freeways, pedestrian and bicycle paths, and mass transit?

Construction of the project would temporarily affect traffic circulation within the project APE and its adjoining roads. However, an approved Traffic Control Plan would be implemented during construction so that traffic circulation would not be substantially impacted. Therefore, the project would not result in an increase of traffic which is substantial in relation to existing traffic capacity.

- b) Conflict with an applicable congestion management program, including, but not limited to level of service standards and travel demand measures, or other standards established by the county congestion management agency for designated roads or highways?

Construction of the project would temporarily affect traffic circulation within the project APE and its adjoining roads. However, an approved Traffic Control Plan would be implemented during construct so that traffic would not exceed cumulative or individual level of service.

- c) Result in a change in air traffic patterns, including either an increase in traffic levels or a change in location that results in substantial safety risks?

The project does not include any tall structures or new features that could affect air traffic patterns or introduce new safety hazards related to air traffic.

- d) Substantially increase hazards due to a design feature (e.g., sharp curves or dangerous intersections) or incompatible uses (e.g., farm equipment)?

The project will be designed to meet City design standards and, therefore, would meet existing levels of safety.

- e) Result in inadequate emergency access?

Construction of the project would temporarily affect traffic circulation within the project APE and adjoining roads. However, an approved Traffic Control Plan would be implemented during construction so that there would be adequate emergency access.

- f) Conflict with adopted policies, plans, or programs regarding public transit, bicycle, or pedestrian facilities, or otherwise decrease the performance or safety of such facilities?

The project, once completed would improve the condition of the existing PROW including safety hazards which currently occur in the existing bicycle path. The project does not have the potential to conflict with any alternative transportation policies.

XVII. UTILITIES AND SERVICE

SYSTEMS – Would the project:

- a) Exceed wastewater treatment requirements of the applicable Regional Water Quality Control Board?

The project would not exceed the requirements of the Regional Water Quality Control Board.

- b) Require or result in the construction of new water or wastewater treatment facilities or expansion of existing facilities, the construction of which could cause significant environmental effects?

The project would not require the construction of any new water or wastewater treatment facilities.

- c) Require or result in the construction of new storm water drainage facilities or expansion of existing facilities, the construction of which could cause significant environmental effects?

The project would not result in expanded impervious surface area and would not result in substantial quantities of runoff which would require new or expanded treatment facilities. Therefore, the project would not require the construction of new storm water drainage facilities or expansion of existing facilities.

- d) Have sufficient water supplies available to serve the project from existing entitlements and resources, or are new or expanded entitlements needed?

The project would not require the use of any permanent water source and, therefore, would not impact existing water supplies.

- e) Result in a determination by the wastewater treatment provider which serves or may serve the project that it has adequate capacity to serve the project's projected demand in addition to the provider's existing commitments?

The project would not generate wastewater and, therefore, would not impact an existing wastewater treatment provider.

- f) Be served by a landfill with sufficient permitted capacity to accommodate the project's solid waste disposal needs?

Construction of the project would likely generate waste associated with construction activities. This waste would be disposed of in conformance with all applicable local and state regulations pertaining to solid waste including permitting capacity of the landfill serving the project area. Operation of the project would not generate waste and, therefore, would not affect the permitted capacity of the landfill serving the project area.

- g) Comply with federal, state, and local statutes and regulation related to solid waste?

The project would not generate solid waste and, therefore, would not affect solid waste statutes and regulations.

XVIII. MANDATORY FINDINGS OF SIGNIFICANCE -

- a) Does the project have the potential to degrade the quality of

the environment, substantially reduce the habitat of a fish or wildlife species, cause a fish or wildlife population to drop below self-sustaining levels, threaten to eliminate a plant or animal community, reduce the number or restrict the range of a rare or endangered plant or animal or eliminate important examples of the major periods of California history or prehistory?

The project is located within the developed public right of way and is not located within or adjacent to wildlife preserves. The project is located within and adjacent to area known to contain significant historical/archaeological resources. Construction activities associated with the project have the potential to impact buried archaeological resources. See V a.

An Archaeological Mitigation Program which includes hand excavation for specific project elements and archaeological/Native American monitoring would be required. Implementation of the mitigation requirements outlined in Section V of the MND would reduce potential impacts to Historical Resources (Archaeology) to below a level of significance and would not result in a substantial adverse change to the significance of a historical resource or eliminate important examples of California history or prehistory.

- b) Does the project have impacts that are individually limited, but cumulatively considerable? (“Cumulatively considerable” means that the incremental effects of a project are considerable when viewed in connection with the effects of past projects, the effects of other current projects, and the effects of probable future projects)?
-

When viewed in connection with the effects of other projects in the La Jolla area, construction activities has the potential to impact archaeological resources which could incrementally contribute to a cumulative loss of non-renewable resources. However, with implementation of the mitigation measures in Section V of the MND, this incremental impact would be reduced to below a level of significance.

- c) Does the project have environmental effects, which will cause substantial adverse effects on human beings, either directly
-

or indirectly?

As stated previously, potentially significant impacts have been identified for Archaeological Resources. However, a mitigation program has been incorporated which would reduce potential impacts to archaeological resources to below a level of significance.

INITIAL STUDY CHECKLIST

REFERENCES

I. AESTHETICS / NEIGHBORHOOD CHARACTER

City of San Diego General Plan.

Community Plan.

Local Coastal Plan.

II. AGRICULTURAL RESOURCES & FOREST RESOURCES

City of San Diego General Plan.

U.S. Department of Agriculture, Soil Survey - San Diego Area, California, Part I and II, 1973.

California Agricultural Land Evaluation and Site Assessment Model (1997).

Site Specific Report:

III. AIR QUALITY

California Clean Air Act Guidelines (Indirect Source Control Programs) 1990.

Regional Air Quality Strategies (RAQS) - APCD.

Site Specific Report:

IV. BIOLOGY

City of San Diego, Multiple Species Conservation Program (MSCP), Subarea Plan, 1997

City of San Diego, MSCP, "Vegetation Communities with Sensitive Species and Vernal Pools" Maps, 1996.

City of San Diego, MSCP, "Multiple Habitat Planning Area" maps, 1997.

Community Plan - Resource Element.

California Department of Fish and Game, California Natural Diversity Database, "State and Federally-listed Endangered, Threatened, and Rare Plants of California," January 2001.

California Department of Fish & Game, California Natural Diversity Database, "State and Federally-listed Endangered and Threatened Animals of California," January 2001.

City of San Diego Land Development Code Biology Guidelines.
 Site Specific Report:

V. CULTURAL RESOURCES (INCLUDES HISTORICAL RESOURCES)

City of San Diego Historical Resources Guidelines.
 City of San Diego Archaeology Library.
 Historical Resources Board List.
 Community Historical Survey:
 Site Specific Report: *Cultural Resources Constraints Analysis, Torrey Pines Road Improvements Phase I, LSA Associates, Inc. (November 2013).*

VI. GEOLOGY/SOILS

City of San Diego Seismic Safety Study.
 U.S. Department of Agriculture Soil Survey - San Diego Area, California, Part I and II, December 1973 and Part III, 1975.
 Site Specific Report:

VII. GREENHOUSE GAS EMISSIONS

Site Specific Report: California Air Pollution Control Officers Association (CAPCOA), 2008. "Evaluating and Addressing Greenhouse Gas Emissions from Projects Subject to the California Environmental Quality Act"
<http://www.climatechange.ca.gov/publications/others/CAPCOA-1000-2008-010.PDF>

VIII. HAZARDS AND HAZARDOUS MATERIALS

San Diego County Hazardous Materials Environmental Assessment Listing,
 San Diego County Hazardous Materials Management Division
 FAA Determination
 State Assessment and Mitigation, Unauthorized Release Listing, Public Use Authorized.
 Airport Land Use Compatibility Plan.
 Site Specific Report:

IX. HYDROLOGY/WATER QUALITY

Flood Insurance Rate Map (FIRM).

- Federal Emergency Management Agency (FEMA), National Flood Insurance Program - Flood Boundary and Floodway Map.
- Clean Water Act Section 303(b) list, http://www.swrcb.ca.gov/tmdl/303d_lists.html.
- Site Specific Report:

X. LAND USE AND PLANNING

- City of San Diego General Plan.
- Community Plan.
- Airport Land Use Compatibility Plan
- City of San Diego Zoning Maps
- FAA Determination

XI. MINERAL RESOURCES

- California Department of Conservation - Division of Mines and Geology, Mineral Land Classification.
- Division of Mines and Geology, Special Report 153 - Significant Resources Maps.
- Site Specific Report:

XII. NOISE

- Community Plan
- San Diego International Airport - Lindbergh Field CNEL Maps.
- Brown Field Airport Master Plan CNEL Maps.
- Montgomery Field CNEL Maps.
- San Diego Association of Governments - San Diego Regional Average Weekday Traffic Volumes.
- San Diego Metropolitan Area Average Weekday Traffic Volume Maps, SANDAG.
- City of San Diego General Plan.
- Site Specific Report:

XIII. PALEONTOLOGICAL RESOURCES

- City of San Diego Paleontological Guidelines.

- ___ Deméré, Thomas A., and Stephen L. Walsh, "Paleontological Resources City of San Diego," Department of Paleontology San Diego Natural History Museum, 1996.
- X Kennedy, Michael P., and Gary L. Peterson, "Geology of the San Diego Metropolitan Area, California. Del Mar, La Jolla, Point Loma, La Mesa, Poway, and SW 1/4 Escondido 7 1/2 Minute Quadrangles," California Division of Mines and Geology Bulletin 200, Sacramento, 1975.
- ___ Kennedy, Michael P., and Siang S. Tan, "Geology of National City, Imperial Beach and Otay Mesa Quadrangles, Southern San Diego Metropolitan Area, California," Map Sheet 29, 1977.
- ___ Site Specific Report:

XIV. POPULATION / HOUSING

- ___ City of San Diego General Plan.
- ___ Community Plan.
- ___ Series 11 Population Forecasts, SANDAG.
- ___ Other:

XV. PUBLIC SERVICES

- X City of San Diego General Plan.
- X Community Plan.

XVI. RECREATIONAL RESOURCES

- X City of San Diego General Plan.
- X Community Plan.
- ___ Department of Park and Recreation
- ___ City of San Diego - San Diego Regional Bicycling Map
- ___ Additional Resources:

XVII. TRANSPORTATION / CIRCULATION

- X City of San Diego General Plan.
- ___ Community Plan.
- ___ San Diego Metropolitan Area Average Weekday Traffic Volume Maps, SANDAG.

- ___ San Diego Region Weekday Traffic Volumes, SANDAG.
- ___ Site Specific Report:

XVIII. UTILITIES

- X City of San Diego General Plan.
- X Community Plan.

XIX. WATER CONSERVATION

- ___ Sunset Magazine, New Western Garden Book. Rev. ed. Menlo Park, CA: Sunset Magazine.

NOTICE OF EXEMPTION

(Check one or both)

TO: X RECORDER/COUNTY CLERK
P.O. BOX 1750, MS A-33
1600 PACIFIC HWY, ROOM 260
SAN DIEGO, CA 92101-2422

FROM: CITY OF SAN DIEGO
DEVELOPMENT SERVICES DEPARTMENT
1222 FIRST AVENUE, MS 501
SAN DIEGO, CA 92101

OFFICE OF PLANNING AND RESEARCH
1400 TENTH STREET, ROOM 121
SACRAMENTO, CA 95814

PROJECT NO.: 236131

PROJECT TITLE: Torrey Pines Slope Restoration

PROJECT LOCATION-SPECIFIC: The project is located on the south side of Torrey Pines Road between Little Street and Roseland Drive within the La Jolla Community Plan.

PROJECT LOCATION-CITY/COUNTY: San Diego/San Diego

DESCRIPTION OF NATURE AND PURPOSE OF THE PROJECT: Approval of the Site Development Permit (SDP) would allow for the reconstruction of a sloughing slope and the replacement of the existing gunite retaining wall with a new retaining wall. The new retaining wall is being constructed in order to protect Torrey Pines Road from the eroding slope. The new wall would be approximately 335 foot long and would have a simulated boulderscape face and would vary in height from 13 feet to 25 feet. The top of the new wall would have 44-inch high posts and cable safety railings with a concrete brow ditch immediately behind the wall. The toe of the slope would be excavated to allow for the required space for the wall installation.

NAME OF PUBLIC AGENCY APPROVING PROJECT: City of San Diego

NAME OF PERSON OR AGENCY CARRYING OUT PROJECT: City of San Diego Engineering and Capital Projects, Contact Bill Mercer, (619) 533-5455.

EXEMPT STATUS: (CHECK ONE)

- () MINISTERIAL (SEC. 21080(b)(1); 15268);
() DECLARED EMERGENCY (SEC. 21080(b)(3); 15269(a));
() EMERGENCY PROJECT (SEC. 21080(b)(4); 15269 (b)(c))
(X) CATEGORICAL EXEMPTIONS: 15302 (REPLACEMENT OR RECONSTRUCTION)
() STATUTORY EXEMPTION:

REASONS WHY PROJECT IS EXEMPT: The City of San Diego has determined that the project meets the categorical exemption criteria set forth in CEQA State Guidelines Section 15302. The exemption allows for the replacement or reconstruction of existing facilities where the new structure will be located on the same site and will have substantially the same purpose. Since the project would replace the existing retaining wall and reconstruct the hillside it was determined that the exemption applies. A biological survey report was prepared and determined that the construction of the wall would not result in significant impacts to biological resources. Because the textured and colored boulderscape pattern on the new wall would be consistent with the natural setting of the area and would have a higher aesthetic value than the existing gunite wall significant visual impact would not occur. It was determined that minimal changes to the environment would occur due to the implementation of the project and the exceptions listed in CEQA Section 21080.21 would not apply.

LEAD AGENCY CONTACT PERSON: JEFF SZYMANSKI

TELEPHONE: (619) 446-5324

IF FILED BY APPLICANT:

- 1. ATTACH CERTIFIED DOCUMENT OF EXEMPTION FINDING.
2. HAS A NOTICE OF EXEMPTION BEEN FILED BY THE PUBLIC AGENCY APPROVING THE PROJECT?
() YES () NO

IT IS HEREBY CERTIFIED THAT THE CITY OF SAN DIEGO HAS DETERMINED THE ABOVE ACTIVITY TO BE EXEMPT FROM CEQA

Handwritten signature: Jeff E. Szymanski SENIOR PLANNER

October 8, 2013
DATE

CHECK ONE:

- (X) SIGNED BY LEAD AGENCY
() SIGNED BY APPLICANT

DATE RECEIVED FOR FILING WITH COUNTY CLERK OR OPR:

APPENDIX B
FIRE HYDRANT METER PROGRAM

CITY OF SAN DIEGO CALIFORNIA DEPARTMENT INSTRUCTIONS	NUMBER DI 55.27	DEPARTMENT Water Department
SUBJECT FIRE HYDRANT METER PROGRAM (FORMERLY: CONSTRUCTION METER PROGRAM)	PAGE 10 OF 10	EFFECTIVE DATE October 15, 2002
	SUPERSEDES DI 55.27	DATED April 21, 2000

1. **PURPOSE**

- 1.1 To establish a Departmental policy and procedure for issuance, proper usage and charges for fire hydrant meters.

2. **AUTHORITY**

- 2.1 All authorities and references shall be current versions and revisions.
- 2.2 San Diego Municipal Code (NC) Chapter VI, Article 7, Sections 67.14 and 67.15
- 2.3 Code of Federal Regulations, Safe Drinking Water Act of 1986
- 2.4 California Code of Regulations, Titles 17 and 22
- 2.5 California State Penal Code, Section 498B.0
- 2.6 State of California Water Code, Section 110, 500-6, and 520-23
- 2.7 Water Department Director

Reference

- 2.8 State of California Guidance Manual for Cross Connection Programs
- 2.9 American Water Works Association Manual M-14, Recommended Practice for Backflow Prevention
- 2.10 American Water Works Association Standards for Water Meters
- 2.11 U.S.C. Foundation for Cross Connection Control and Hydraulic Research Manual

3. **DEFINITIONS**

- 3.1 **Fire Hydrant Meter:** A portable water meter which is connected to a fire hydrant for the purpose of temporary use. (These meters are sometimes referred to as Construction Meters.)

CITY OF SAN DIEGO CALIFORNIA DEPARTMENT INSTRUCTIONS	NUMBER DI 55.27	DEPARTMENT Water Department
SUBJECT FIRE HYDRANT METER PROGRAM (FORMERLY: CONSTRUCTION METER PROGRAM)	PAGE 2 OF 10	EFFECTIVE DATE October 15, 2002
	SUPERSEDES DI 55.27	DATED April 21, 2000

3.2 **Temporary Water Use:** Water provided to the customer for no longer than twelve (12) months.

3.3 **Backflow Preventor:** A Reduced Pressure Principal Assembly connected to the outlet side of a Fire Hydrant Meter.

4. **POLICY**

4.1 The Water Department shall collect a deposit from every customer requiring a fire hydrant meter and appurtenances prior to providing the meter and appurtenances (see Section 7.1 regarding the Fees and Deposit Schedule). The deposit is refundable upon the termination of use and return of equipment and appurtenances in good working condition.

4.2 Fire hydrant meters will have a 2 ½" swivel connection between the meter and fire hydrant. The meter shall not be connected to the 4" port on the hydrant. All Fire Hydrant Meters issued shall have a Reduced Pressure Principle Assembly (RP) as part of the installation. Spanner wrenches are the only tool allowed to turn on water at the fire hydrant.

4.3 The use of private hydrant meters on City hydrants is prohibited, with exceptions as noted below. All private fire hydrant meters are to be phased out of the City of San Diego. All customers who wish to continue to use their own fire hydrant meters must adhere to the following conditions:

a. Meters shall meet all City specifications and American Water Works Association (AWWA) standards.

b. Customers currently using private fire hydrant meters in the City of San Diego water system will be allowed to continue using the meter under the following conditions:

1. The customer must submit a current certificate of accuracy and calibration results for private meters and private backflows annually to the City of San Diego, Water Department, Meter Shop.

CITY OF SAN DIEGO CALIFORNIA DEPARTMENT INSTRUCTIONS	NUMBER DI 55.27	DEPARTMENT Water Department
SUBJECT FIRE HYDRANT METER PROGRAM (FORMERLY: CONSTRUCTION METER PROGRAM)	PAGE 3 OF 10	EFFECTIVE DATE October 15, 2002
	SUPERSEDES DI 55.27	DATED April 21, 2000

2. The meter must be properly identifiable with a clearly labeled serial number on the body of the fire hydrant meter. The serial number shall be plainly stamped on the register lid and the main casing. Serial numbers shall be visible from the top of the meter casing and the numbers shall be stamped on the top of the inlet casing flange.
3. All meters shall be locked to the fire hydrant by the Water Department, Meter Section (see Section 4.7).
4. All meters shall be read by the Water Department, Meter Section (see Section 4.7).
5. All meters shall be relocated by the Water Department, Meter Section (see Section 4.7).
6. These meters shall be tested on the anniversary of the original test date and proof of testing will be submitted to the Water Department, Meter Shop, on a yearly basis. If not tested, the meter will not be allowed for use in the City of San Diego.
7. All private fire hydrant meters shall have backflow devices attached when installed.
8. The customer must maintain and repair their own private meters and private backflows.
9. The customer must provide current test and calibration results to the Water Department, Meter Shop after any repairs.
10. When private meters are damaged beyond repair, these private meters will be replaced by City owned fire hydrant meters.

CITY OF SAN DIEGO CALIFORNIA DEPARTMENT INSTRUCTIONS	NUMBER DI 55.27	DEPARTMENT Water Department
SUBJECT FIRE HYDRANT METER PROGRAM (FORMERLY: CONSTRUCTION METER PROGRAM)	PAGE 4 OF 10	EFFECTIVE DATE October 15, 2002
	SUPERSEDES DI 55.27	DATED April 21, 2000

11. When a private meter malfunctions, the customer will be notified and the meter will be removed by the City and returned to the customer for repairs. Testing and calibration results shall be given to the City prior to any re-installation.
 12. The register shall be hermetically sealed straight reading and shall be readable from the inlet side. Registration shall be in hundred cubic feet.
 13. The outlet shall have a 2 ½ “National Standards Tested (NST) fire hydrant male coupling.
 14. Private fire hydrant meters shall not be transferable from one contracting company to another (i.e. if a company goes out of business or is bought out by another company).
- 4.4 All fire hydrant meters and appurtenances shall be installed, relocated and removed by the City of San Diego, Water Department. All City owned fire hydrant meters and appurtenances shall be maintained by the City of San Diego, Water Department, Meter Services.
- 4.5 If any fire hydrant meter is used in violation of this Department Instruction, the violation will be reported to the Code Compliance Section for investigation and appropriate action. Any customer using a fire hydrant meter in violation of the requirements set forth above is subject to fines or penalties pursuant to the Municipal Code, Section 67.15 and Section 67.37.
- 4.6 **Conditions and Processes for Issuance of a Fire Hydrant Meter**
- Process for Issuance
- a. Fire hydrant meters shall only be used for the following purposes:
 1. Temporary irrigation purposes not to exceed one year.

CITY OF SAN DIEGO CALIFORNIA DEPARTMENT INSTRUCTIONS	NUMBER DI 55.27	DEPARTMENT Water Department
SUBJECT FIRE HYDRANT METER PROGRAM (FORMERLY: CONSTRUCTION METER PROGRAM)	PAGE 5 OF 10	EFFECTIVE DATE October 15, 2002
	SUPERSEDES DI 55.27	DATED April 21, 2000

2. Construction and maintenance related activities (see Tab 2).

- b. No customer inside or outside the boundaries of the City of San Diego Water Department shall resell any portion of the water delivered through a fire hydrant by the City of San Diego Water Department.
- c. The City of San Diego allows for the issuance of a temporary fire hydrant meter for a period not to exceed 12 months (365 days). An extension can only be granted in writing from the Water Department Director for up to 90 additional days. A written request for an extension by the consumer must be submitted at least 30 days prior to the 12 month period ending. No extension shall be granted to any customer with a delinquent account with the Water Department. No further extensions shall be granted.
- d. Any customer requesting the issuance of a fire hydrant meter shall file an application with the Meter Section. The customer must complete a "Fire Hydrant Meter Application" (Tab 1) which includes the name of the company, the party responsible for payment, Social Security number and/or California ID, requested location of the meter (a detailed map signifying an exact location), local contact person, local phone number, a contractor's license (or a business license), description of specific water use, duration of use at the site and full name and address of the person responsible for payment.
- e. At the time of the application the customer will pay their fees according to the schedule set forth in the Rate Book of Fees and Charges, located in the City Clerk's Office. All fees must be paid by check, money order or cashiers check, made payable to the City Treasurer. Cash will not be accepted.
- f. No fire hydrant meters shall be furnished or relocated for any customer with a delinquent account with the Water Department.
- g. After the fees have been paid and an account has been created, the

CITY OF SAN DIEGO CALIFORNIA DEPARTMENT INSTRUCTIONS	NUMBER DI 55.27	DEPARTMENT Water Department
SUBJECT FIRE HYDRANT METER PROGRAM (FORMERLY: CONSTRUCTION METER PROGRAM)	PAGE 6 OF 10	EFFECTIVE DATE October 15, 2002
	SUPERSEDES DI 55.27	DATED April 21, 2000

meter shall be installed within 48 hours (by the second business day). For an additional fee, at overtime rates, meters can be installed within 24 hours (within one business day).

4.7 Relocation of Existing Fire Hydrant Meters

- a. The customer shall call the Fire Hydrant Meter Hotline (herein referred to as "Hotline"), a minimum of 24 hours in advance, to request the relocation of a meter. A fee will be charged to the existing account, which must be current before a work order is generated for the meter's relocation.
- b. The customer will supply in writing the address where the meter is to be relocated (map page, cross street, etc). The customer must update the original Fire Hydrant Meter Application with any changes as it applies to the new location.
- c. Fire hydrant meters shall be read on a monthly basis. While fire hydrant meters and backflow devices are in service, commodity, base fee and damage charges, if applicable, will be billed to the customer on a monthly basis. If the account becomes delinquent, the meter will be removed.

4.8 Disconnection of Fire Hydrant Meter

- a. After ten (10) months a "Notice of Discontinuation of Service" (Tab 3) will be issued to the site and the address of record to notify the customer of the date of discontinuance of service. An extension can only be granted in writing from the Water Department Director for up to 90 additional days (as stated in Section 4.6C) and a copy of the extension shall be forwarded to the Meter Shop Supervisor. If an extension has not been approved, the meter will be removed after twelve (12) months of use.
- b. Upon completion of the project the customer will notify the Meter Services office via the Hotline to request the removal of the fire hydrant meter and appurtenances. A work order will be generated

CITY OF SAN DIEGO CALIFORNIA DEPARTMENT INSTRUCTIONS	NUMBER DI 55.27	DEPARTMENT Water Department
SUBJECT FIRE HYDRANT METER PROGRAM (FORMERLY: CONSTRUCTION METER PROGRAM)	PAGE 7 OF 10	EFFECTIVE DATE October 15, 2002
	SUPERSEDES DI 55.27	DATED April 21, 2000

for removal of the meter.

- c. Meter Section staff will remove the meter and backflow prevention assembly and return it to the Meter Shop. Once returned to the Meter Shop the meter and backflow will be tested for accuracy and functionality.
- d. Meter Section Staff will contact and notify Customer Services of the final read and any charges resulting from damages to the meter and backflow or its appurtenance. These charges will be added on the customer's final bill and will be sent to the address of record. Any customer who has an outstanding balance will not receive additional meters.
- e. Outstanding balances due may be deducted from deposits and any balances refunded to the customer. Any outstanding balances will be turned over to the City Treasurer for collection. Outstanding balances may also be transferred to any other existing accounts.

5. **EXCEPTIONS**

- 5.1 Any request for exceptions to this policy shall be presented, in writing, to the Customer Support Deputy Director, or his/her designee for consideration.

6. **MOBILE METER**

- 6.1 Mobile meters will be allowed on a case by case basis. All mobile meters will be protected by an approved backflow assembly and the minimum requirement will be a Reduced Pressure Principal Assembly. The two types of Mobile Meters are vehicle mounted and floating meters. Each style of meters has separate guidelines that shall be followed for the customer to retain service and are described below:

- a) **Vehicle Mounted Meters:** Customer applies for and receives a City owned Fire Hydrant Meter from the Meter Shop. The customer mounts the meter on the vehicle and brings it to the Meter Shop for

CITY OF SAN DIEGO CALIFORNIA DEPARTMENT INSTRUCTIONS	NUMBER DI 55.27	DEPARTMENT Water Department
SUBJECT FIRE HYDRANT METER PROGRAM (FORMERLY: CONSTRUCTION METER PROGRAM)	PAGE 8 OF 10	EFFECTIVE DATE October 15, 2002
	SUPERSEDES DI 55.27	DATED April 21, 2000

inspection. After installation is approved by the Meter Shop the vehicle and meter shall be brought to the Meter Shop on a monthly basis for meter reading and on a quarterly basis for testing of the backflow assembly. Meters mounted at the owner's expense shall have the one year contract expiration waived and shall have meter or backflow changed if either fails.

b) **Floating Meters:** Floating Meters are meters that are not mounted to a vehicle. **(Note: All floating meters shall have an approved backflow assembly attached.)** The customer shall submit an application and a letter explaining the need for a floating meter to the Meter Shop. The Fire Hydrant Meter Administrator, after a thorough review of the needs of the customer, (i.e. number of jobsites per day, City contract work, lack of mounting area on work vehicle, etc.), may issue a floating meter. At the time of issue, it will be necessary for the customer to complete and sign the "Floating Fire Hydrant Meter Agreement" which states the following:

- 1) The meter will be brought to the Meter Shop at 2797 Caminito Chollas, San Diego on the third week of each month for the monthly read by Meter Shop personnel.
- 2) Every other month the meter will be read and the backflow will be tested. This date will be determined by the start date of the agreement.

If any of the conditions stated above are not met the Meter Shop has the right to cancel the contract for floating meter use and close the account associated with the meter. The Meter Shop will also exercise the right to refuse the issuance of another floating meter to the company in question.

Any Fire Hydrant Meter using reclaimed water shall not be allowed use again with any potable water supply. The customer shall incur the cost of replacing the meter and backflow device in this instance.

CITY OF SAN DIEGO CALIFORNIA DEPARTMENT INSTRUCTIONS	NUMBER DI 55.27	DEPARTMENT Water Department
SUBJECT FIRE HYDRANT METER PROGRAM (FORMERLY: CONSTRUCTION METER PROGRAM)	PAGE 9 OF 10	EFFECTIVE DATE October 15, 2002
	SUPERSEDES DI 55.27	DATED April 21, 2000

7. **FEE AND DEPOSIT SCHEDULES**

7.1 **Fees and Deposit Schedules:** The fees and deposits, as listed in the Rate Book of Fees and Charges, on file with the Office of the City Clerk, are based on actual reimbursement of costs of services performed, equipment and materials. These deposits and fees will be amended, as needed, based on actual costs. Deposits, will be refunded at the end of the use of the fire hydrant meter, upon return of equipment in good working condition and all outstanding balances on account are paid. Deposits can also be used to cover outstanding balances.

All fees for equipment, installation, testing, relocation and other costs related to this program are subject to change without prior notification. The Mayor and Council will be notified of any future changes.

8. **UNAUTHORIZED USE OF WATER FROM A HYDRANT**

8.1 Use of water from any fire hydrant without a properly issued and installed fire hydrant meter is theft of City property. Customers who use water for unauthorized purposes or without a City of San Diego issued meter will be prosecuted.

8.2 If any unauthorized connection, disconnection or relocation of a fire hydrant meter, or other connection device is made by anyone other than authorized Water Department personnel, the person making the connection will be prosecuted for a violation of San Diego Municipal Code, Section 67.15. In the case of a second offense, the customer's fire hydrant meter shall be confiscated and/or the deposit will be forfeited.

8.3 Unauthorized water use shall be billed to the responsible party. Water use charges shall be based on meter readings, or estimates when meter readings are not available.

8.4 In case of unauthorized water use, the customer shall be billed for all applicable charges as if proper authorization for the water use had been obtained, including but not limited to bi-monthly service charges, installation charges and removal charges.

CITY OF SAN DIEGO CALIFORNIA DEPARTMENT INSTRUCTIONS	NUMBER DI 55.27	DEPARTMENT Water Department
SUBJECT FIRE HYDRANT METER PROGRAM (FORMERLY: CONSTRUCTION METER PROGRAM)	PAGE 10 OF 10	EFFECTIVE DATE October 15, 2002
	SUPERSEDES DI 55.27	DATED April 21, 2000

- 8.5 If damage occurs to Water Department property (i.e. fire hydrant meter, backflow, various appurtenances), the cost of repairs or replacements will be charged to the customer of record (applicant).

Water Department Director

- Tabs:
1. Fire Hydrant Meter Application
 2. Construction & Maintenance Related Activities With No Return To Sewer
 3. Notice of Discontinuation of Service

APPENDIX

Administering Division: Customer Support Division

Subject Index: Construction Meters
Fire Hydrant
Fire Hydrant Meter Program
Meters, Floating or Vehicle Mounted
Mobile Meter
Program, Fire Hydrant Meter

Distribution: DI Manual Holders



Application for Fire Hydrant Meter (EXHIBIT A)

(For Office Use Only)

NS REQ	FAC#
DATE	BY

METER SHOP (619) 527-7449

Meter Information

Application Date	Requested Install Date:
------------------	-------------------------

Fire Hydrant Location: (Attach Detailed Map//Thomas Bros. Map Location or Construction drawing.) <u>Zip:</u>	T.B.	G.B. (CITY USE)
Specific Use of Water:		
Any Return to Sewer or Storm Drain, if so, explain:		
Estimated Duration of Meter Use: <input type="text"/>	<input type="checkbox"/>	Check Box If Reclaimed Water

Company Information

Company Name:			
Mailing Address:			
City:	State:	Zip:	Phone: ()
*Business license#		*Contractor license#	
A Copy of the Contractor's license OR Business License is required at the time of meter issuance.			
Name and Title of Billing Agent: <small>(PERSON IN ACCOUNTS PAYABLE)</small>			Phone: ()
Site Contact Name and Title:			Phone: ()
Responsible Party Name:			Title:
Cal ID#			Phone: ()
Signature:		Date:	
Guarantees Payment of all Charges Resulting from the use of this Meter. Insures that employees of this Organization understand the proper use of Fire Hydrant Meter			

Fire Hydrant Meter Removal Request	Requested Removal Date:
Provide Current Meter Location if Different from Above:	
Signature:	Title: Date:
Phone: ()	Pager: ()

<input type="checkbox"/> City Meter	<input type="checkbox"/> Private Meter
Contract Acct #:	Deposit Amount: \$ 936.00 Fees Amount: \$ 62.00
Meter Serial #	Meter Size: 05 Meter Make and Style: 6-7
Backflow #	Backflow Size: Backflow Make and Style:
Name:	Signature: Date:

WATER USES WITHOUT ANTICIPATED CHARGES FOR RETURN TO SEWER

Auto Detailing
Backfilling
Combination Cleaners (Vactors)
Compaction
Concrete Cutters
Construction Trailers
Cross Connection Testing
Dust Control
Flushing Water Mains
Hydro Blasting
Hydro Seeing
Irrigation (for establishing irrigation only; not continuing irrigation)
Mixing Concrete
Mobile Car Washing
Special Events
Street Sweeping
Water Tanks
Water Trucks
Window Washing

Note:

1. If there is any return to sewer or storm drain, then sewer and/or storm drain fees will be charges.

Date

Name of Responsible Party
Company Name and Address
Account Number: _____

Subject: Discontinuation of Fire Hydrant Meter Service

Dear Water Department Customer:

~~The authorization for use of Fire Hydrant Meter # _____, located at (Meter Location Address)~~
ends in 60 days and will be removed on or after (Date Authorization Expires). Extension requests for an
additional 90 days must be submitted in writing for consideration 30 days prior to the discontinuation
date. If you require an extension, please contact the Water Department, or mail your request for an
extension to:

City of San Diego
Water Department
Attention: Meter Services
2797 Caminito Chollas
San Diego, CA 92105-5097

Should you have any questions regarding this matter, please call the Fire Hydrant Hotline at (619) _____ -
_____.

Sincerely,

Water Department

APPENDIX C

MATERIALS TYPICALLY ACCEPTED BY CERTIFICATE OF COMPLIANCE

Materials Typically Accepted by Certificate of Compliance

1. Soil amendment
2. Fiber mulch
3. PVC or PE pipe up to 16 inch diameter
4. Stabilizing emulsion
5. Lime
6. Preformed elastomeric joint seal
7. Plain and fabric reinforced elastomeric bearing pads
8. Steel reinforced elastomeric bearing pads
9. Waterstops (Special Condition)

10. Epoxy coated bar reinforcement
11. Plain and reinforcing steel
12. Structural steel
13. Structural timber and lumber
14. Treated timber and lumber
15. Lumber and timber
16. Aluminum pipe and aluminum pipe arch
17. Corrugated steel pipe and corrugated steel pipe arch
18. Structural metal plate pipe arches and pipe arches
19. Perforated steel pipe
20. Aluminum underdrain pipe
21. Aluminum or steel entrance tapers, pipe downdrains, reducers, coupling bands and slip joints
22. Metal target plates
23. Paint (traffic striping)
24. Conductors
25. Painting of electrical equipment
26. Electrical components
27. Engineering fabric
28. Portland Cement
29. PCC admixtures
30. Minor concrete, asphalt
31. Asphalt (oil)
32. Liquid asphalt emulsion
33. Epoxy

APPENDIX D

SAMPLE CITY INVOICE WITH SPEND CURVE

City of San Diego, CM&FS Div., 9753 Chesapeake Drive, SD CA 92123

Project Name:

Work Order No or Job Order No.

City Purchase Order No.

Resident Engineer (RE):

RE Phone#: Fax#:

Contractor's Name:

Contractor's Address:

Contractor's Phone #:

Contractor's fax #:

Contact Name:

Invoice No.

Invoice Date:

Billing Period: (To)

Item #	Item Description	Contract Authorization				Previous Totals To Date		This Estimate		Totals to Date	
		Unit	Price	Qty	Extension	%/QTY	Amount	% / QTY	Amount	% / QTY	Amount
1					\$ -		\$ -		\$ -	0.00	\$ -
2					\$ -		\$ -		\$ -	0.00%	\$ -
3					\$ -		\$ -		\$ -	0.00%	\$ -
4					\$ -		\$ -		\$ -	0.00%	\$ -
5					\$ -		\$ -		\$ -	0.00%	\$ -
6					\$ -		\$ -		\$ -	0.00%	\$ -
7					\$ -		\$ -		\$ -	0.00%	\$ -
8					\$ -		\$ -		\$ -	0.00%	\$ -
5					\$ -		\$ -		\$ -	0.00%	\$ -
6					\$ -		\$ -		\$ -	0.00%	\$ -
7					\$ -		\$ -		\$ -	0.00%	\$ -
8					\$ -		\$ -		\$ -	0.00%	\$ -
9					\$ -		\$ -		\$ -	0.00%	\$ -
10					\$ -		\$ -		\$ -	0.00%	\$ -
11					\$ -		\$ -		\$ -	0.00%	\$ -
12					\$ -		\$ -		\$ -	0.00%	\$ -
13					\$ -		\$ -		\$ -	0.00%	\$ -
14					\$ -		\$ -		\$ -	0.00%	\$ -
15					\$ -		\$ -		\$ -	0.00%	\$ -
16					\$ -		\$ -		\$ -	0.00%	\$ -
17	Field Orders				\$ -		\$ -		\$ -	0.00%	\$ -
	CHANGE ORDER No.				\$ -		\$ -		\$ -	0.00%	\$ -
					\$ -		\$ -		\$ -	0.00%	\$ -
					\$ -		\$ -		\$ -	0.00%	\$ -
Total Authorized Amount (including approved Change Order)					\$ -		\$ -		\$ -	Total Billed	\$ -

SUMMARY

A. Original Contract Amount	\$ -
B. Approved Change Order #00 Thru #00	\$ -
C. Total Authorized Amount (A+B)	\$ -
D. Total Billed to Date	\$ -
E. Less Total Retention (5% of D)	\$ -
F. Less Total Previous Payments	\$ -
G. Payment Due Less Retention	\$0.00
H. Remaining Authorized Amount	\$0.00

I certify that the materials
have been received by me in
the quality and quantity specified

Resident Engineer

Construction Engineer

Retention and/or Escrow Payment Schedule

Total Retention Required as of this billing (Item E)	\$0.00
Previous Retention Withheld in PO or in Escrow	\$0.00
Add'l Amt to Withhold in PO/Transfer in Escrow:	\$0.00
Amt to Release to Contractor from PO/Escrow:	

Contractor Signature and Date: _____

Sample Project Spend Curve

Sample Date Entries Required

Incremental Curve Value
Duration % Increment

0.0%	3.5%	3.5%	3.5%	3.5%	3.5%	3.5%	3.5%	3.5%	3.5%	3.5%	6.5%	6.5%	6.5%	6.5%	6.5%	6.5%	6.5%	6.5%	6.5%	6.5%
0%	5%	10%	15%	20%	25%	30%	35%	40%	45%	50%	55%	60%	65%	70%	75%	80%	85%	90%	95%	100%

Sample Screenshot from Primavera P6

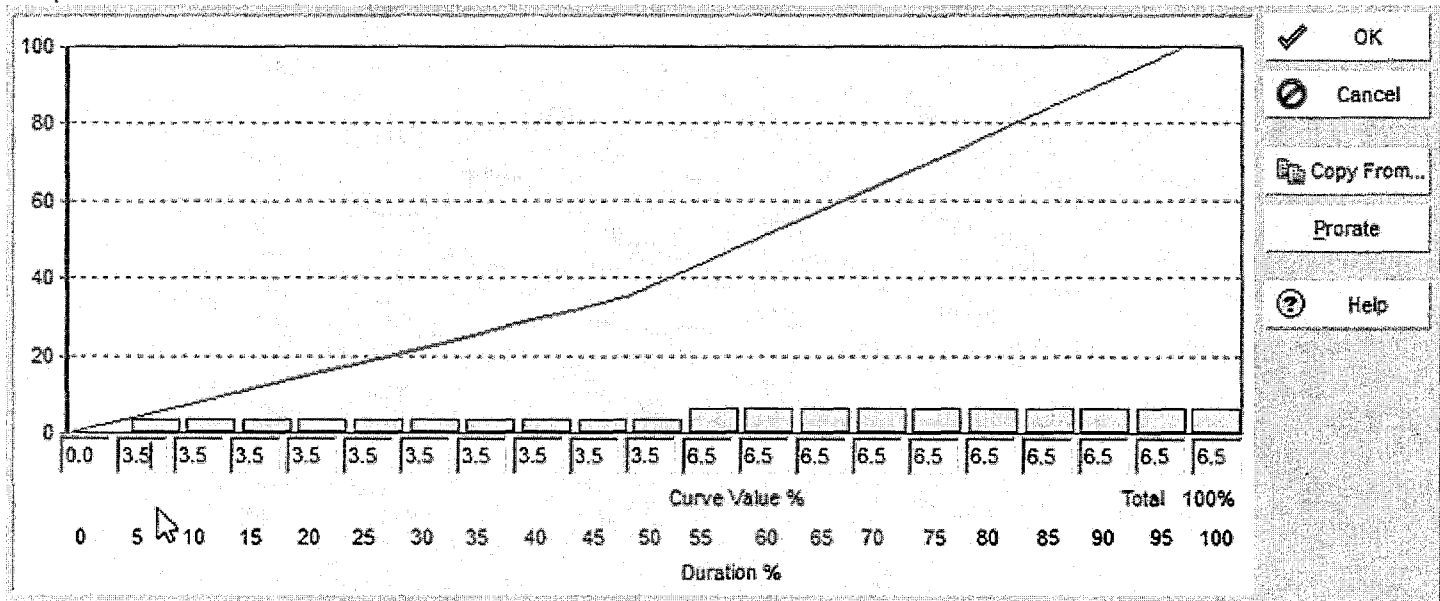

APPENDIX E
LOCATION MAP

**TORREY PINES ROAD IMPROVEMENTS PHASE 2
and TORREY PINES ROAD SLOPE RESTORATION**

SENIOR ENGINEERS
BRAD JOHNSON 619-533-5120
MAHMOUD ORIQAT 619-533-5232

PROJECT MANAGER TEAM
STEVEN BLISS 619-533-4668
JASON GUISE 619-533-4665

FOR QUESTIONS
ABOUT THIS PROJECT
Call: 619-533-4207
Email: engineering@sandiego.gov

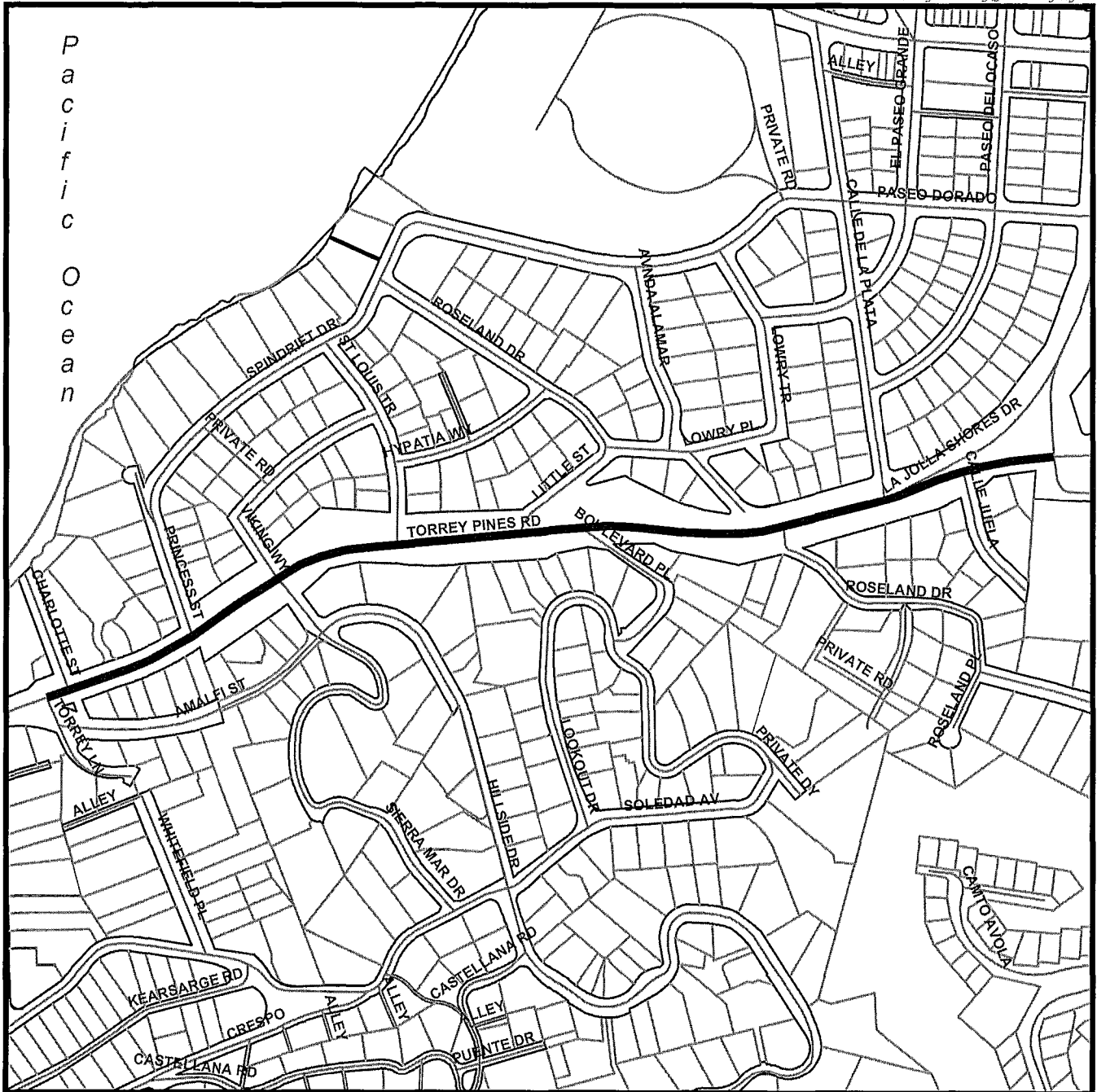
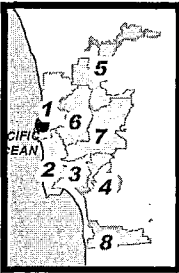

Legend

— Project Location

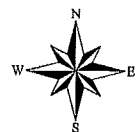

THIS MAP/DATA IS PROVIDED WITHOUT WARRANTY OF ANY KIND, EITHER EXPRESS OR IMPLIED, INCLUDING, BUT NOT LIMITED TO, THE IMPLIED WARRANTIES OR MERCHANTABILITY AND FITNESS FOR A PARTICULAR PURPOSE. Note: This product may contain information from the SANDAG Regional Information System which cannot be reproduced without the written permission of SANDAG. This product may contain information reproduced with permission granted by RAND McNALLY & COMPANY to SanGIS. This map is copyrighted by RAND McNALLY & COMPANY. It is unlawful to copy or reproduce all or any part thereof, whether for personal use or resale, without the prior, written permission of RAND McNALLY & COMPANY.

APPENDIX F
ADJACENT PROJECTS

THIS MAP/DATA IS PROVIDED WITHOUT WARRANTY OF ANY KIND, EITHER EXPRESS OR IMPLIED, INCLUDING, BUT NOT LIMITED TO, THE IMPLIED WARRANTIES OR MERCHANTABILITY AND FITNESS FOR A PARTICULAR PURPOSE. Note: This product may contain information from the SANDAG Regional Information System which cannot be reproduced without the written permission of SANDAG. This product may contain information reproduced with permission granted by RAND MCNALLY & COMPANY® to SanGIS. This map is copyrighted by RAND MCNALLY & COMPANY®. It is unlawful to copy or reproduce all or any part thereof, whether for personal use or resale, without the prior, written permission of RAND MCNALLY & COMPANY.

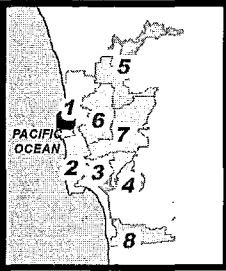

The City of
SAN DIEGO Public Works
AC WATER AND SEWER GROUP 1011
 (ADJACENT TO TORREY PINES ROAD IMPROVEMENTS PHASE 2)

SENIOR ENGINEER
 MICHAEL NINH
 619-533-7443

PROJECT MANAGER
 IKHLASS SHAMOUN
 619-533-4619

PROJECT ENGINEER
 CARLOS NAVARO
 619-627-3106

FOR QUESTIONS
 ABOUT THIS PROJECT
 Call: 619-533-4207
 Email: engineering@sandiego.gov

P
a
c
i
f
i
c

O
c
e
a
n

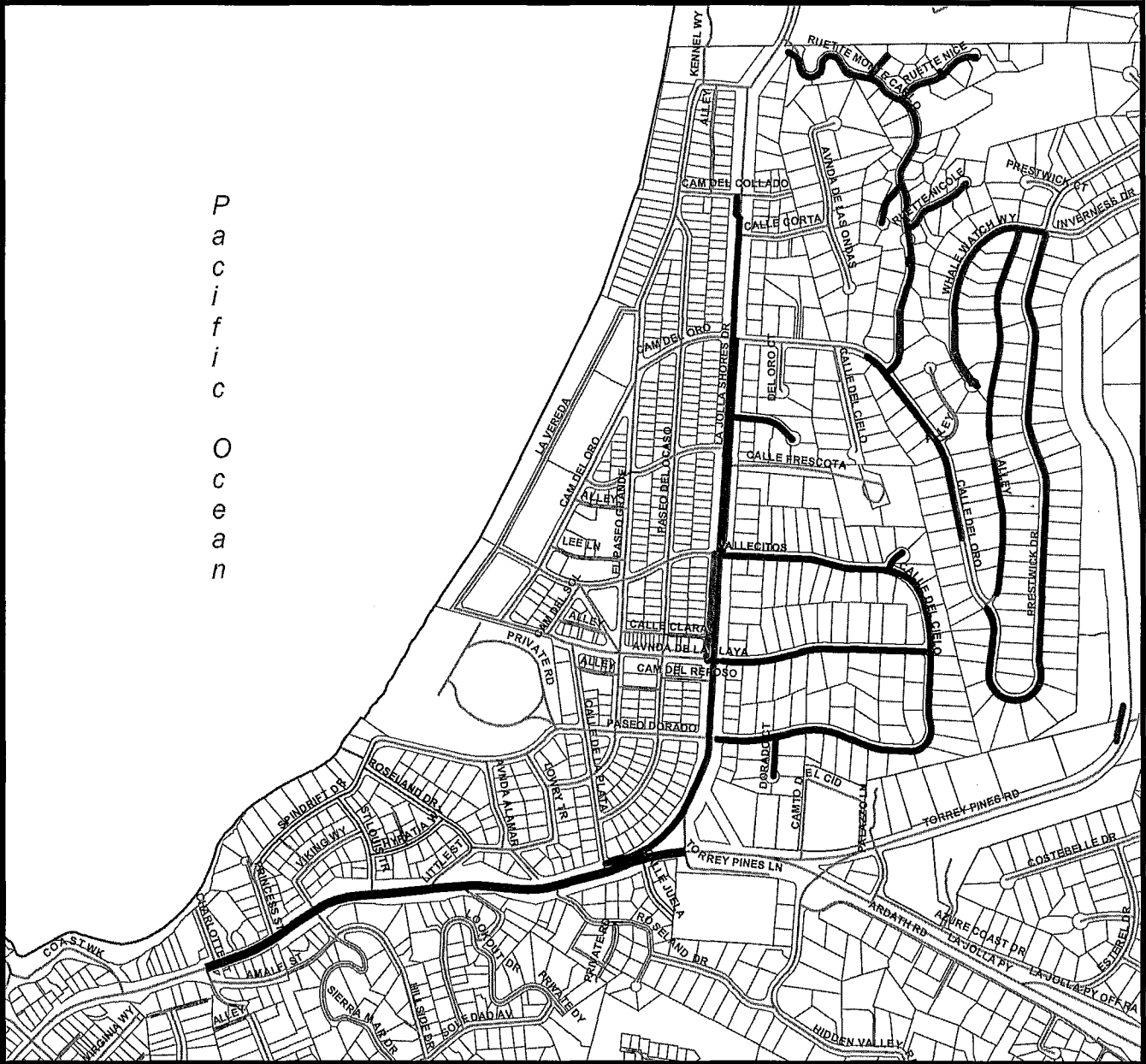

Legend

- SEWER PROJECT
- AC WATER PROJECT
- TORREY PINES RD IMPROVEMENTS PHASE 2 PROJECT

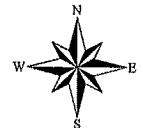

COMMUNITY NAME: LA JOLLA

COUNCIL DISTRICT: 1

SAP ID: B-15040 (S)
 B-15041 (W)

Date: MARCH 2, 2017



Appendix F - Adjacent Projects

APPENDIX G
DISCHARGE POINTS AND FLOW DATA

Chlorination Discharge Locations for Torrey Pines

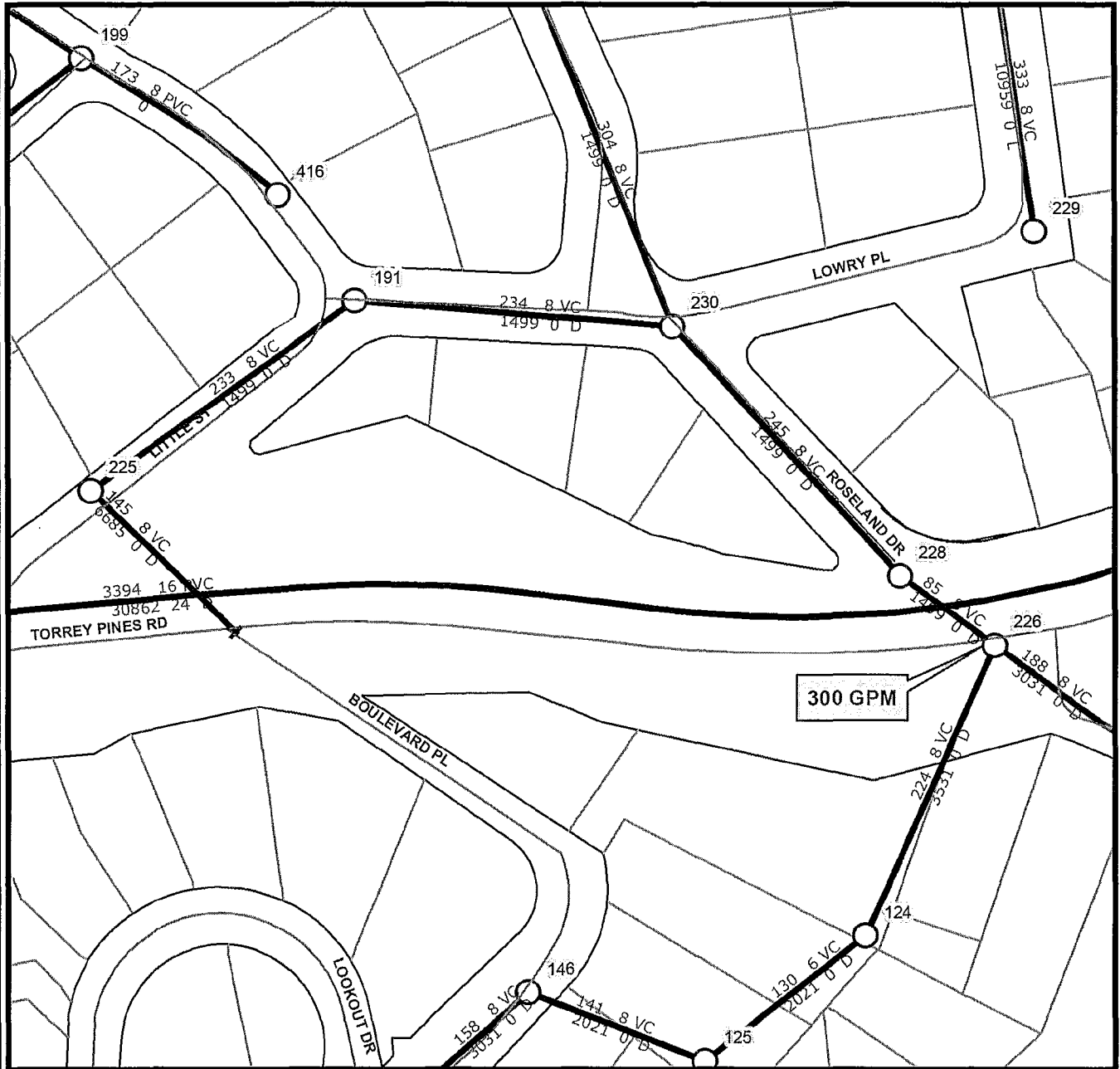

APPENDIX H
HAZARDOUS LABEL/FORMS

INCIDENT/RELEASE ASSESSMENT FORM ¹

If you have an emergency, Call 911

Handlers of hazardous materials are required to report releases. The following is a tool to be used for assessing if a release is reportable. Additionally, a non-reportable release incident form is provided to document why a release is not reported (see back).

Questions for Incident Assessment:

	YES	NO
1. Was anyone killed or injured, or did they require medical care or admitted to a hospital for observation?	<input type="checkbox"/>	<input type="checkbox"/>
2. Did anyone, other than employees in the immediate area of the release, evacuate?	<input type="checkbox"/>	<input type="checkbox"/>
3. Did the release cause off-site damage to public or private property?	<input type="checkbox"/>	<input type="checkbox"/>
4. Is the release greater than or equal to a reportable quantity (RQ)?	<input type="checkbox"/>	<input type="checkbox"/>
5. Was there an uncontrolled or unpermitted release to the air?	<input type="checkbox"/>	<input type="checkbox"/>
6. Did an uncontrolled or unpermitted release escape secondary containment, or extend into any sewers, storm water conveyance systems, utility vaults and conduits, wetlands, waterways, public roads, or off site?	<input type="checkbox"/>	<input type="checkbox"/>
7. Will control, containment, decontamination, and/or clean up require the assistance of federal, state, county, or municipal response elements?	<input type="checkbox"/>	<input type="checkbox"/>
8. Was the release or threatened release involving an unknown material or contains an unknown hazardous constituent?	<input type="checkbox"/>	<input type="checkbox"/>
9. Is the incident a threatened release (a condition creating a substantial probability of harm that requires immediate action to prevent, reduce, or mitigate damages to persons, property, or the environment)?	<input type="checkbox"/>	<input type="checkbox"/>
10. Is there an increased potential for secondary effects including fire, explosion, line rupture, equipment failure, or other outcomes that may endanger or cause exposure to employees, the general public, or the environment?	<input type="checkbox"/>	<input type="checkbox"/>

If the answer is YES to any of the above questions – report the release to the California Office of Emergency Services at 800-852-7550 and the local CUPA daytime: (619) 338-2284, after hours: (858) 565-5255. Note: other state and federal agencies may require notification depending on the circumstances.

Call 911 in an emergency

If all answers are NO, complete a Non Reportable Release Incident Form (page 2 of 2) and keep readily available. Documenting why a “no” response was made to each question will serve useful in the event questions are asked in the future, and to justify not reporting to an outside regulatory agency.

If in doubt, report the release.

¹ This document is a guide for accessing when hazardous materials release reporting is required by Chapter 6.95 of the California Health and Safety Code. It does not replace good judgment, Chapter 6.95, or other state or federal release reporting requirements.

NON REPORTABLE RELEASE INCIDENT FORM

1. RELEASE AND RESPONSE DESCRIPTION

Incident # _____

Date/Time Discovered	Date/Time Discharge	Discharge Stopped <input type="checkbox"/> Yes <input type="checkbox"/> No
Incident Date / Time:		
Incident Business / Site Name:		
Incident Address:		
Other Locators (Bldg, Room, Oil Field, Lease, Well #, GIS)		
Please describe the incident and indicate specific causes and area affected. Photos Attached?: <input type="checkbox"/> Yes <input type="checkbox"/> No		
Indicate actions to be taken to prevent similar releases from occurring in the future.		

2. ADMINISTRATIVE INFORMATION

Supervisor in charge at time of incident:	Phone:
Contact Person:	Phone:

3. CHEMICAL INFORMATION

Chemical	Quantity <input type="checkbox"/> GAL <input type="checkbox"/> LBS <input type="checkbox"/> FT ³
Chemical	Quantity <input type="checkbox"/> GAL <input type="checkbox"/> LBS <input type="checkbox"/> FT ³
Chemical	Quantity <input type="checkbox"/> GAL <input type="checkbox"/> LBS <input type="checkbox"/> FT ³
Clean-Up Procedures & Timeline:	
Completed By:	Phone:
Print Name:	Title:

EMERGENCY RELEASE FOLLOW - UP NOTICE REPORTING FORM

A	BUSINESS NAME	FACILITY EMERGENCY CONTACT & PHONE NUMBER () -
B	INCIDENT MO DAY YR DATE	TIME OES NOTIFIED (use 24 hr time)
C	INCIDENT ADDRESS LOCATION	CITY / COMMUNITY COUNTY ZIP
D	CHEMICAL OR TRADE NAME (print or type)	CAS Number
E	CHECK IF CHEMICAL IS LISTED IN 40 CFR 355, APPENDIX A <input type="checkbox"/>	CHECK IF RELEASE REQUIRES NOTIFICATION UNDER 42 U.S.C. Section 9603 (a) <input type="checkbox"/>
F	PHYSICAL STATE CONTAINED <input type="checkbox"/> SOLID <input type="checkbox"/> LIQUID <input type="checkbox"/> GAS	PHYSICAL STATE RELEASED <input type="checkbox"/> SOLID <input type="checkbox"/> LIQUID <input type="checkbox"/> GAS
G	ENVIRONMENTAL CONTAMINATION <input type="checkbox"/> AIR <input type="checkbox"/> WATER <input type="checkbox"/> GROUND <input type="checkbox"/> OTHER	QUANTITY RELEASED TIME OF RELEASE DURATION OF RELEASE — DAYS — HOURS — MINUTES
H	ACTIONS TAKEN	
I	KNOWN OR ANTICIPATED HEALTH EFFECTS (Use the comments section for addition information) <input type="checkbox"/> ACUTE OR IMMEDIATE (explain) _____ <input type="checkbox"/> CHRONIC OR DELAYED (explain) _____ <input type="checkbox"/> NOTKNOWN (explain) _____	
J	ADVISE REGARDING MEDICAL ATTENTION NECESSARY FOR EXPOSED INDIVIDUALS	
K	COMMENTS (INDICATE SECTION (A - G) AND ITEM WITH COMMENTS OR ADDITIONAL INFORMATION)	
L	CERTIFICATION: I certify under penalty of law that I have personally examined and I am familiar with the information submitted and believe the sub mitted information is true, accurate, and complete. REPORTING FACILITY REPRESENTATIVE (print or type) _____ SIGNATURE OF REPORTING FACILITY REPRESENTATIVE _____ DATE: _____	

EMERGENCY RELEASE FOLLOW-UP NOTICE REPORTING FORM INSTRUCTIONS

GENERAL INFORMATION:

Chapter 6.95 of Division 20 of the California Health and Safety Code requires that written emergency release follow-up notices prepared pursuant to 42 U.S.C. § 11004, be submitted using this reporting form. Non-permitted releases of reportable quantities of Extremely Hazardous Substances (listed in 40 CFR 355, appendix A) or of chemicals that require release reporting under section 103(a) of the Comprehensive Environmental Response, Compensation, and Liability Act of 1980 [42 U.S.C. § 9603(a)] must be reported on the form, as soon as practicable, but no later than 30 days, following a release. The written follow-up report is required in addition to the verbal notification.

BASIC INSTRUCTIONS:

- The form, when filled out, reports follow-up information required by 42 U.S.C § 11004. Ensure that all information requested by the form is provided as completely as possible.
- If the incident involves reportable releases of more than one chemical, prepare one report form for each chemical released.
- If the incident involves a series of separate releases of chemical(s) at different times, the releases should be reported on separate reporting forms.

SPECIFIC INSTRUCTIONS:

Block A: Enter the name of the business and the name and phone number of a contact person who can provide detailed facility information concerning the release.

Block B: Enter the date of the incident and the time that verbal notification was made to OES. The OES control number is provided to the caller by OES at the time verbal notification is made. Enter this control number in the space provided.

Block C: Provide information pertaining to the location where the release occurred. Include the street address, the city or community, the county and the zip code.

Block D: Provide information concerning the specific chemical that was released. Include the chemical or trade name and the Chemical Abstract Service (CAS) number. Check all categories that apply. Provide best available information on quantity, time and duration of the release.

Block E: Indicate all actions taken to respond to and contain the release as specified in 42 U.S.C. § 11004(c).

Block F: Check the categories that apply to the health effects that occurred or could result from the release. Provide an explanation or description of the effects in the space provided. Use Block H for additional comments/information if necessary to meet requirements specified in 42 U.S.C. § 11004(c).

Block G: Include information on the type of medical attention required for exposure to the chemical released. Indicate when and how this information was made available to individuals exposed and to medical personnel, if appropriate for the incident, as specified in 42 U.S.C. § 11004(c).

Block H: List any additional pertinent information.

Block I: Print or type the name of the facility representative submitting the report. Include the official signature and the date that the form was prepared.

MAIL THE COMPLETED REPORT TO:

**State Emergency Response Commission (SERC)
Attn: Section 304 Reports
Hazardous Materials Unit
3650 Schriever Avenue
Mather, CA 95655**

NOTE: Authority cited: Sections 25503, 25503.1 and 25507.1, Health and Safety Code. Reference: Sections 25503(b)(4), 25503.1, 25507.1, 25518 and 25520, Health and Safety Code.

HAZARDOUS WASTE

**STATE AND FEDERAL LAW PROHIBITS IMPROPER DISPOSAL
IF FOUND, CONTACT THE NEAREST POLICE, OR PUBLIC SAFETY
AUTHORITY, OR THE U.S. ENVIRONMENTAL PROTECTION AGENCY
OR THE CALIFORNIA DEPARTMENT OF HEALTH SERVICES**

GENERATOR NAME _____

ADDRESS _____ 24 HR. PHONE _____

CITY _____ STATE _____ ZIP _____

EPA ID NO. _____ MANIFEST DOCUMENT NO. _____

EPA WASTE NO. _____ CA WASTE NO. _____ ACCUMULATION START DATE _____

CONTENTS, COMPOSITION _____

PROPER DOT SHIPPING NAME _____

TECHNICAL NAME (S) _____

UN/NA NO. WITH PREFIX _____

PHYSICAL STATE | HAZARDOUS PROPERTIES | FLAMMABLE | TOXIC
 SOLID LIQUID | CORROSIVE | REACTIVE | OTHER _____

HANDLE WITH CARE!

CONTAINS HAZARDOUS OR TOXIC WASTES

APPENDIX I

SAMPLE ARCHAEOLOGY INVOICE

(FOR ARCHAEOLOGY ONLY)

Company Name
Address, telephone, fax

Date: Insert Date

To: Name of Resident Engineer
City of San Diego
Field Engineering Division
9485 Aero Drive
San Diego, CA 92123-1801

Project Name: Insert Project Name

SAP Number (WBS/IO/CC): Insert SAP Number

Drawing Number: Insert Drawing Number

Invoice period: Insert Date to Insert Date

Work Completed: Bid item Number - Description of Bid Item - Quantity - Unit Price - Amount

Detailed summary of work completed under this bid item: Insert detailed description of Work related to Archaeology Monitoring Bid item. See Note 1 below.

Summary of charges:

Description of Services	Name	Start Date	End Date	Total Hours	Hourly Rate	Amount
Field Archaeologist	Joe Smith	8/29/2011	9/2/2011	40	\$84	\$3,360
Laboratory Assistant	Jane Doe	8/29/2011	9/2/2011	2	\$30	\$60
Subtotal						\$3,420

Work Completed: Bid item Number - Description of Bid Item - Quantity - Unit Price - Amount

Detailed summary of work completed under this bid item: Insert detailed description of Work related to Archaeology Curation/Discovery Bid item. See Note 2 below.

Summary of charges:

Description of Services	Where work occurred (onsite vs offsite/lab)	Name	Start Date	End Date	Total Hours	Hourly Rate	Amount
Field Archaeologist		Joe Smith	8/29/2011	9/2/2011	40	\$84	\$3,360
Laboratory Assistant		Jane Doe	8/29/2011	9/2/2011	2	\$30	\$60
Subtotal							\$3,420

Total this invoice: \$ _____

Total invoiced to date: \$ _____

Note 1:

For monitoring related bid items or work please include summary of construction work that was monitored from Station to Station, Native American monitors present, MMC coordination, status and nature of monitoring and if any discoveries were made.

Note 2:

For curation/discovery related bid items or work completed as part of a discovery and curation process, the PI must provide a response to the following questions along with the invoice:

1. Preliminary results of testing including tentative recommendations regarding eligibility for listing in the California Register of Historical Resources (California Register).
 - a. Please briefly describe your application (consideration) of all four California Register criteria.
 - b. If the resource is eligible under Criterion D, please define the important information that may be present.
 - c. Were specialized studies performed? How many personnel were required? How many Native American monitors were present?
 - d. What is the age of the resource?
 - e. Please define types of artifacts to be collected and curated, including quantity of boxes to be submitted to the San Diego Archaeological Center (SDAC). How many personnel were required? How many Native American monitors were present?
2. Preliminary results of data recovery and a definition of the size of the representative sample.
 - a. Were specialized studies performed? Please define types of artifacts to be collected and curated, including quantity of boxes to be submitted to the SDAC. How many personnel were required? How many Native American monitors were present?
3. What resources were discovered during monitoring?
4. What is the landform context and what is the integrity of the resources?
5. What additional studies are necessary?
6. Based on application of the California Register criteria, what is the significance of the resources?
 - a. If the resource is eligible for the California Register, can the resource be avoided by construction?
 - b. If not, what treatment (mitigation) measures are proposed? Please define data to be recovered (if necessary) and what material will be submitted to the SDAC for curation. Are any specialized studies proposed?

(After the first invoice, not all the above information needs to be re-stated, just revise as applicable).

APPENDIX J

AREAS OF SPECIAL BIOLOGICAL SIGNIFICANCE MAP

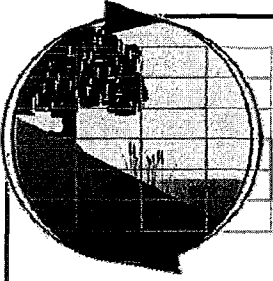

Merkel & Associates, Inc.

5434 Ruffin Road, San Diego, CA 92123

Tel: 858/560-5465 • Fax: 858/560-7779

e-mail: associates@merkelinc.com

Revised September 19, 2012

June 29, 2012

M&A #09-088-23

Ms. Carrie Purcell
Engineering and Capital Projects Department
City of San Diego
600 B Street, Suite 800, MS 908A
San Diego, CA 9101-4501

**Biological Survey Letter Report
Torrey Pines Slope Restoration, Located in the City of San Diego
(WBS# S-00877.02.02)**

Dear Ms. Purcell,

Merkel & Associates, Inc. has prepared the following biological letter report for the City of San Diego, Engineering and Capital Projects Department. If you have any questions concerning this biological letter report, please do not hesitate to contact me at (858) 560-5465 or gkrantz@merkelinc.com.

Sincerely,

Gina Krantz
Project Manager

Keith W. Merkel
Principal Consultant

INTRODUCTION

Merkel & Associates, Inc. (M&A) has prepared this biological survey letter report, written in accordance with the current City of San Diego (City) Guidelines for Conducting Biological Surveys (2002), for the proposed Torrey Pines Slope Restoration Project (Project). The purpose of this report is to document the existing biological conditions within the project study area; identify potential impacts to biological resources that could result from implementation of the proposed project; and recommend measures to avoid, minimize, and/or mitigate significant impacts pursuant to the California Environmental Quality Act (CEQA) and applicable federal, state, and local regulations and guidelines, including the City's Multiple Species Conservation Program (MSCP) Subarea Plan (1997), Biology Guidelines (2001), Environmentally Sensitive Land Regulations (2010), and Significance Determination Thresholds (2011).

The project site is located on City of San Diego public right-of-way within unsectioned lands of Township 15 South, Range 4 West of the San Bernardino Base and Meridian, U.S. Geological Survey (USGS) La Jolla, California 7.5-minute Quadrangle (Latitude 32.85 and Longitude - 117.2586) (Figure 1).

The proposed project consists of the construction of a 350-foot long soil nail wall and drainage system along the south side of Torrey Pines Road between Little Street and Roseland Drive within the La Jolla Community Plan area. The purpose of the soil nail wall is to replace the existing deteriorated/failed shotcrete wall, stabilize the slope, and prevent further erosion. The soil nail has been designed to have a natural, faux rock appearance.

All construction of the proposed project would occur from the public right-of-way. No access would be taken from the adjacent private property. Construction of the soil nail wall would result in an approximately 0.30-acre (13,068-square-foot) impact area, as shown on the 30% project plans by Leighton and Associates, Inc. (Sheet 2 of 9). An approximately 0.15-acre (6,534-square-foot) staging area is proposed along the north side of Torrey Pines Road directly across from the location of the soil nail wall within a vacant lot immediately adjacent to the sidewalk. The staging area has been included within the results of this biological survey.

METHODS AND SURVEY LIMITATIONS

LITERATURE AND DATA REVIEW

Historical and currently available biological literature and data pertaining to the study area were reviewed prior to initiation of the field investigation. This review included examination of: 1) aerial photography for the project site (Bing Maps 2010, Microsoft Corporation); 2) regional vegetation data for the project vicinity (SanGIS 2010); 3) geological substrates and soil types mapped on the project site (USGS 2005 and USDA NRCS 2007, respectively); and 4) California Department of Fish and Game (CDFG) California Natural Diversity Database (CNDDB) and U.S. Fish and Wildlife Service (USFWS) special status species records for the project vicinity (CDFG 2012a, and USFWS 2011, respectively).

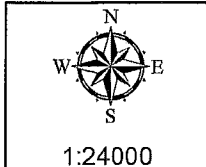
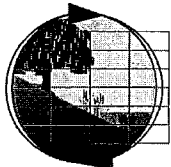
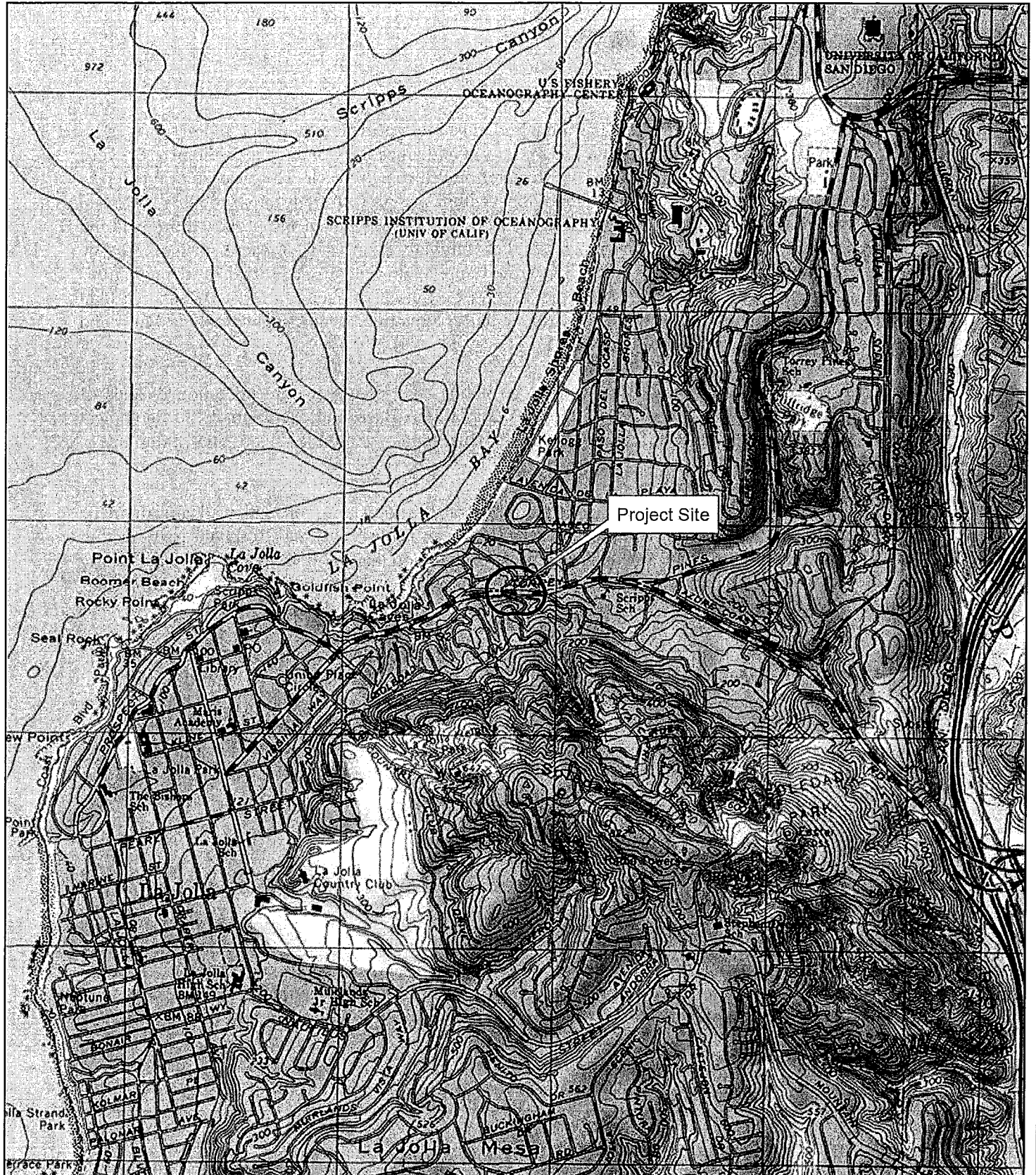

Project Vicinity Map
 Torrey Pines Road Slope Restoration Project
 Source: USGS 7.5' La Jolla, CA Quadrangle

Figure 1

SURVEY DATES, TIMES, AND CONDITIONS

On June 13, 2012 an M&A biologist conducted a general biological survey for the site. The study area included a buffer area of approximately 100 feet beyond all proposed project elements.

Table 1. Summary of Survey Dates, Times, Conditions, and Staff

Date	Time	Weather Conditions ¹	Biologist	Survey
June 13, 2012	1215-1430	Weather: 50%-75% cc Wind: 1 BS Temperature: 62°-64°F	Adam Behle	General Biological Survey

¹ cc = cloud cover; BS= Beaufort Scale; F = Fahrenheit

GENERAL BIOLOGICAL SURVEY

Existing vegetation types were delineated onto a 1" = 100' scale, color aerial photograph (Air Photo USA, 2007). The vegetation types were classified according to the Holland (1986) code classification system as modified by Oberbauer (2008) and were mapped in accordance with the City's current biological resource mapping requirements (2002). A list of detectable flora and fauna species were recorded in a field notebook. Plant identifications were either resolved in the field or later determined through verification of voucher specimens, and wildlife species were determined through direct observation (aided by binoculars), identification of songs, call notes and alarm calls, or by detection of sign (e.g., burrows, tracks, scat, etc.). In addition, directed searches for sensitive species as well as any active avian/raptor nests with a potential to occur onsite were conducted within the study area, and any other potential occurrences were assessed in the field based on the existing biological conditions. Photographs of the project study area were taken to record the biological resources present, and data collected from the survey were digitized into current Geographical Information System (GIS) Environmental Systems Research Institute (ESRI) software platforms.

The scientific and common names utilized for the floral and faunal resources were noted according to the following scientific nomenclature: flora, Rebman and Simpson (2006); butterflies, Klein/San Diego Natural History Museum (2002); amphibians and reptiles, Crother et al. (2001 and 2003); birds, American Ornithologists' Union (1998 and 2010); and mammals, San Diego Natural History Museum (undated), which uses Wilson and Reeder (2005) for species names and Hall (1981) for subspecies.

GENERAL SURVEY LIMITATIONS

Biological inventories are generally subject to various survey limitations. Depending on the season and time of day during which field surveys are conducted, some species may not be detected due to temporal species variability. The biological surveys conducted for this project were performed during daylight hours in early summer; thus, some potential migratory/wintering species or nocturnal species may not have been detected. Based on the literature review performed, as well as knowledge of species-specific habitat requirements, however, it is anticipated that any additional species potentially present on the project site can be fairly accurately predicted, and that the surveys conducted were sufficient in obtaining a thorough review of the biological resources present on the project site.

SURVEY RESULTS

PHYSICAL CHARACTERISTICS

The approximate 1.6-acre project site is located on City of San Diego right-of-way lands within the La Jolla Community Plan area, along the south side of Torrey Pines Road between Little Street and Roseland Drive. The project site is located approximately 1,200 feet east of the Pacific Ocean and 6,900 feet west of Interstate-5. The existing conditions of the proposed project site includes a steep cut slope with deteriorating concrete armament that extends from the paved surface of Torrey Pines Road at 90 feet National Vertical Datum (NVD) to approximately 116 feet NVD. The proposed staging area on the other side of Torrey Pines Road is relatively flat terrain that predominately consists of a City sidewalk and non-native vegetation.

The site is located entirely outside of the City of San Diego's Multi-Habitat Planning Area (MHPA), but is located within the State Coastal Overlay Zone. No U.S. Fish and Wildlife Service (USFWS) designated critical habitat for any listed species occurs within or adjacent to the project area.

The project site and associated staging area is located on either side of Torrey Pines Road, a heavily utilized transportation corridor that is the primary northern thoroughfare to and from downtown La Jolla. The site is bordered primarily by residential development and its associated infrastructure. The landscape in the immediate vicinity of the project site is dominated by an assortment of streetscape plantings and ornamental species that have escaped or recruited from residential sources.

The Soil Survey for Western San Diego County (USDA 1973) identifies two soil mapping units and soil series as occurring within the project site: Corralitos Loamy Sand, 5 to 9 percent slopes (CsD) is located north of Torrey Pines Road; and Altamont Clay, 15 to 30 percent slopes, eroded (AtE2) is located south of Torrey Pines Road. These soil mapping units are not listed in the *California Hydric Soils List* (NRCS 2010) as hydric soils.

The regional climate is characterized by warm, dry summers and mild winters with most of the annual precipitation falling between December and March. Annual rainfall totals average approximately 9–13 inches (USDA-NRCS 2002).

BIOLOGICAL RESOURCES

Botanical Resources-Flora

Two vegetation types were identified within the project study area during the biological survey (Table 2; Figure 2). These vegetation types consist exclusively of non-native dominated or disturbed upland habitats (i.e., City MSCP Tier IV "other uplands"). MSCP Tier IV habitat types include uplands that may provide limited habitat for native floral and faunal species, but are largely dominated by exotic floral species. A complete list of the floral species observed on the project site during the biological survey has been included with this report in Appendix 1.

Table 2. Habitats/Vegetation Communities within Project Study Area

Vegetation Type	Holland/ Oberbauer Code	MSCP Wetland/Upland Tier Habitat Type	Total Area (acres)
Non-Native Vegetation	11000	IV	1.76
Urban/Developed	12000	IV	1.21
Total:			2.98

Non-native Vegetation

Non-native vegetation communities occur on the north-facing slope located south of Torrey Pines Road, in addition to the staging area located north of Torrey Pines Road. This habitat consists of an overstory of mature landscape tree species, with an herbaceous understory comprised almost exclusively of ornamental non-native species. Several Torrey Pine (*Pinus torreyana* ssp. *torreyana*) trees were identified in these areas, but they are presumed to be planted since they are located outside of the native population of the species in Torrey Pines State Reserve, located approximately 2.3 miles to the north. Other large canopy-forming species include eucalyptus, Brazilian pepper (*Schinus terebinthifolius*), Peruvian pepper (*Schinus molle*), and several non-native pine trees (*Pinus* spp.). The understory consists predominantly of non-native shrubs, forbs and grasses. These include, but are not limited to, hottentot-fig (*Carpobrotus edulis*), Algerian ivy (*Hedera canariensis*), ngaio (*Myoporum laetum*), jade plant (*Crassula argentea*), Indian fig (*Opuntia ficus-indica*), acacia (*Acacia* spp.), tree tobacco (*Nicotiana glauca*), garden nasturtium (*Tropaeolum majus*), fennel (*Foeniculum vulgare*), and wild radish (*Raphanus sativus*). The only native species identified included several lemonadeberry (*Rhus integrifolia*) and toyon (*Heteromeles arbutifolia*) within the non-native vegetation located south of Torrey Pines Road.

This habitat is heavily disturbed due to the overwhelming presence of non-native vegetation species that have likely originated from adjacent ornamental and streetscape plantings. However, the area retains some wildlife habitat value for avian species and common mammals that are typically associated with urban environments. Common avian species that are adapted to the presence of humans were identified during the biological survey, including American crow (*Corvus brachyrhynchos*), northern mockingbird (*Mimus polyglottos*), Anna's hummingbird (*Calypte anna*), lesser goldfinch (*Spinus psaltria*), and song sparrow (*Melospiza melodia*). Although no active nests were observed during the survey, the eucalyptus trees provide suitable nesting and foraging habitat potential for urban-tolerant birds and raptors such as American crow and red-tailed hawk (*Buteo jamaicensis*), respectively. One ubiquitous mammal, the California ground squirrel (*Spermophilus beecheyi nudipes*), was observed onsite. Other regionally common mammal species including raccoon (*Procyon lotor psora*), striped skunk (*Mephitis mephitis holzneri*), and Virginia opossum (*Didelphis virginiana*) may occasionally pass through or forage onsite. One common reptile, the western fence lizard (*Sceloporus occidentalis*) was observed onsite. In addition, a few other common reptile species may potentially occur onsite including the southern alligator lizard (*Elgaria multicarinata*) and side-blotched lizard (*Uta stansburiana*).

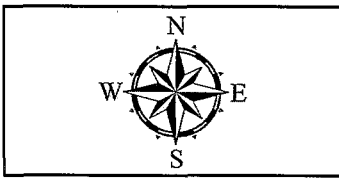
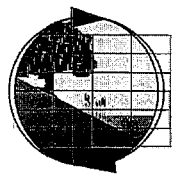

Biological Resources Map
Torrey Pines Road Slope Restoration Project

Figure 2

Urban/Developed

Areas of the site mapped as urban/developed include Torrey Pines Road and any residential development that falls within the project study area. Urban/developed land includes paved and impermeable surfaces, housing, sidewalks, and other areas that are completely devoid of any vegetative cover.

ZOOLOGICAL RESOURCES-FAUNA

A total of 7 fauna species were observed and/or detected within the proposed project study area during the biological survey. All seven of the observed faunal species were common, urban tolerant species. A complete list of fauna species observed by M&A during the survey is provided in Appendix 2.

CITY OF SAN DIEGO ENVIRONMENTALLY SENSITIVE LANDS

Sensitive biological resources are uniquely defined by local jurisdictions. Since the study area lies within the City of San Diego, this report relies upon the City of San Diego's definition of "sensitive biological resources", as documented in the San Diego Municipal Code, Land Development Procedures (Chapter 11, Article 3, and Division 1), and referenced in the Environmentally Sensitive Lands Regulations. Per this definition, sensitive biological resources means upland and/or wetland areas that meet any one of the following criteria:

- (a) lands that have been included in the City of San Diego MSCP Preserve;
- (b) wetlands;
- (c) lands outside the Multiple Habitat Planning Area (MHPA) that contain Tier I habitats, Tier II habitats, Tier IIIA habitats, or Tier IIIB habitats;
- (d) lands supporting species or subspecies listed as rare, endangered, or threatened under Section 670.2 or 670.5, Title 14, California Code of Regulations, or the Federal Endangered Species Act, Title 50, Code of Federal Regulations, Section 17.11 or 17.12, or candidate species under the California Code of Regulations;
- (e) lands containing habitats with narrow endemic species as listed in the Biology Guidelines in the Land Development manual; or
- (f) lands containing habitats of covered species as listed in the Biology Guidelines in the Land Development Manual.

No sensitive biological resources as defined in the City Environmentally Sensitive Lands regulations occur onsite.

RARE, THREATENED, ENDANGERED, ENDEMIC AND/OR SENSITIVE OR MSCP-COVERED SPECIES

Sensitive species are those considered sensitive by the City or any state or federal agency. For the purposes of this report, species listed as endangered or threatened under the federal Endangered Species Act (ESA) and California Endangered Species Act (CESA) (CDFG 2012b, 2011a); species designated as California Special Concern species or Fully Protected species by the CDFG (CDFG 2012c and 2011b); and species listed as MSCP narrow endemics and covered species by the City (1997) are considered "sensitive". Species considered rare by the California Native Plant Society (CNPS) (2010) or as Special Plants or Animals in the CNDDDB (CDFG 2012c and 2011b), may be considered "sensitive" if they meet the CEQA Guidelines §15380 (Title 14, Chapter 3, Article 20) definition for "endangered, rare or threatened species".

Sensitive Flora

Only one sensitive floral species was identified within the project study area during the general biology survey: Torrey pine (CNDDDB Special Plant, MSCP Covered Species, and CNPS 1B.2 rare, threatened, or endangered in CA and elsewhere). However, protection of this species under the MSCP is limited to the historic native populations that are found exclusively within the Torrey Pines State Reserve, located approximately 2.3 miles to the north. The Torrey Pine trees onsite are located outside of the State Reserve, presumed to be planted as a streetscape trees, and thus are not afforded the same protection as native Torrey Pine trees. No focused rare plant surveys were conducted onsite.

No potential sensitive floral species are expected to have at least a moderate potential to occur within the project site primarily due to a lack of required habitat components onsite from heavy urbanization that has occurred onsite and in the project vicinity. No City narrow endemic species are expected to occur onsite.

Table 3 provides a complete listing of any sensitive plant species detected or an evaluation of the potential for sensitive floral species to occur within the study area based on suitable habitat, soils, topography, and/or elevation.

Sensitive Fauna

No sensitive fauna species were observed or detected during the biological survey conducted onsite. Only two sensitive species have at least a moderate potential to occur within the project study area: monarch butterfly (*Danaus plexippus*) and Cooper's hawk (*Accipiter cooperii*). No other potential sensitive faunal species are expected to have at least a moderate potential to occur within the project site primarily due to a lack of suitable habitat.

Table 3 provides a complete listing of any sensitive wildlife species identified during the biological surveys or evaluated for the potential to occur onsite primarily based on suitable habitat.

Table 3. Potential for Rare, Threatened, Endangered, and/or Endemic or Sensitive Species or MSCP covered species on Project Site.

Common Name <i>Scientific Name</i>	Sensitivity Codes and Status ¹	Habitat Preferences/Requirements ²	Potential To Occur On-Site
Plants			
Torrey Pine (<i>Pinus torreyana</i> ssp. <i>torreyana</i>)	CNDDDB: SP CNPS: 1B.2	Closed-cone coniferous forest, chaparral/sandstone; elevation 75-160 meters.	Present. Although this species is present onsite, it is presumed that the trees onsite were planted and not part of the native population located within the Torrey Pines State Reserve that is protected under the City MSCP Subarea Plan.
Invertebrates			
monarch butterfly (<i>Danaus plexippus</i>)	CNDDDB: SA	This species occurs throughout North America, and migrates to wintering sites in central Mexico and along the California coast generally from August to October (Opler et al. 2010). This butterfly utilizes open habitats including fields, meadows, weedy areas, marshes, and roadsides. Caterpillar host plants include milkweeds (<i>Asclepius</i> sp.), and adult nectaring resources include a variety of flowers. In southern California, this butterfly may breed year round.	Moderate Potential. May pass through the site but no host plants were identified or expected to occur within project site.
Amphibians			
No sensitive amphibians expected onsite			
Reptiles			
No sensitive reptiles expected onsite			
Birds			
Cooper's hawk (<i>Accipiter cooperii</i>)	DFG: WL CNDDDB ³ : SA MSCP: CS	A breeding, year-long resident of San Diego County that frequently builds nests consisting of a stick platform lined with bark typically 20 to 50 feet above the ground, in dense stands of live oak, riparian deciduous or other forest habitats located near water and along broken woodland habitat and edges, where it can perch under cover and hunt prey, including amphibians, reptiles, and small birds and mammals	High Potential. This species was not detected during the general biological survey/raptor nest survey; however, it is common in the region and has the potential to nest and forage in the mature trees onsite.

Common Name <i>Scientific Name</i>	Sensitivity Codes and Status ¹	Habitat Preferences/Requirements ²	Potential To Occur On-Site
Mammals			
No sensitive mammals expected onsite			

¹*Sensitivity Codes and Status* (CDFG 2012c and 2011b)

Endangered Species Act (ESA) Listing Codes: FE = Federally-listed as Endangered; FT = Federally-listed as Threatened; FPE = Federally proposed for listing as Endangered; FPT = Federally proposed for listing as Threatened; FPD = Federally proposed for delisting; FC = Federal candidate species (former Category 1 candidates); SC = Species of concern (list established by the National Marine Fisheries Service [NMFS] effective April 15, 2004); Delisted species are monitored for 5 years.

California Endangered Species Act (CESA) Listing Codes: SE = State-listed as Endangered; ST = State-listed as Threatened; SCE = State candidate for listing as Endangered; SCT = State candidate for listing as Threatened; SCD = State candidate for de-listing; SR = California Rare Species.

California Department of Fish and Game (DFG) Sensitivity Codes: CSC = California special concern species; FP = California fully protected species; SR = State-listed rare

California Native Plant Society (CNPS) Sensitivity Codes: List of Species Designation: 1A = Plants presumed extinct in California; 1B = Plants rare, threatened, or endangered in California and elsewhere; 2 = Plants rare, threatened, or endangered in California, but more common elsewhere; 3 = Plants about which more information is needed (a review list); 4 = Plants of limited distribution (a watch list).

California Natural Diversity Database (CNDDDB) Sensitivity Codes: Special Plants (SP)/Special Animals (SA) = A general term that refers to all of the taxa the CNDDDB is interested in tracking, regardless of their legal or protection status; these taxa fall into one of the above categories and/or one or more of the following categories: 1) Taxa which meet the criteria for listing, even if not currently included on any list, as described in Section 15380 of the CEQA Guidelines; 2) A Bureau of Land Management (BLM), U.S. Fish and Wildlife Service (USFWS), or U.S. Forest Service (USFS) Sensitive Species; 3) Taxa that are biologically rare, very restricted in distribution, declining throughout their range, or have a critical, vulnerable stage in their life cycle that warrants monitoring, but not currently threatened with extirpation; 4) Populations in California that may be on the periphery of a taxon's range, but are threatened with extirpation in California; 5) Taxa closely associated with a habitat that is declining in California at an alarming rate (e.g., wetlands, riparian, old growth forests, desert aquatic systems, native grasslands, valley shrubland habitats, vernal pools, etc.); and 6) Taxa designated as a special status, sensitive, or declining species by other state or federal agencies, or non-governmental organization (NGO) (e.g., The World Conservation Union [IUCN], American Fisheries Society [AFS], Audubon Watch List; California Department of Forestry and Fire Protection [CDF], U.S. Department of Agriculture [USDA] Forest Service [FS], Fish and Wildlife Service Birds of Conservation Concern [FWS BCC], The American Bird Conservancy Green List [ABC Green List], The U.S. Bird Conservation [USBC] Watch List, The Western Bat Working Group [WBWG], and The Xerces Society).

Multiple Species Conservation Program (MSCP) Status: Narrow Endemic = NE; Covered Species = CS.

²*References for Habitat Preferences/Requirements:* (plants) Reiser 2001 and CNPS 2010; (butterflies) Opler 2010; (amphibians and reptiles) Stebbins 2003, CDFG 2010; (birds and mammals) CDFG 2010.

³Sensitivity codes and status apply to nesting/wintering sites only

WILDLIFE CORRIDORS

The Torrey Pines Slope Restoration project site is surrounded by urban development and divided by the heavily utilized Torrey Pines Road. While the site has potential to provide foraging and breeding opportunities for common bird species and urban tolerant mammal species, there is no direct connectivity from the project site to open space/natural areas in the project region. No wildlife corridor occurs onsite and/or in proximity to the project site.

PROJECT IMPACT ANALYSIS

CEQA THRESHOLDS OF SIGNIFICANCE

State CEQA Guidelines §15065 (a) (Title 14, Chapter 3, Article 5) states, “A project may have a significant effect on the environment” if:

- “The project has the potential to substantially degrade the quality of the environment; substantially reduce the habitat of a fish or wildlife species; cause a fish or wildlife population to drop below self-sustaining levels; threaten to eliminate a plant or animal community; substantially reduce the number or restrict the range of an endangered, rare or threatened species; or eliminate important examples of the major periods of California history or prehistory.”
- “The project has possible environmental effects which are individually limited but cumulatively considerable.”

The following analysis identifies potential impacts to biological resources that could result from implementation of the proposed project. Project impacts were calculated based on the redline approximate “limits of surface disturbance” for construction of the soil nail wall and the estimated area for the construction staging on the 30% project plans by Leighton and Associates, Inc. (Sheet 2 of 9).

In addition, the City has developed Significance Determination Thresholds (2011) and Biology Guidelines (2001) under CEQA; therefore, mitigation measures for significant project impacts are recommended in accordance with these City guidelines.

PROJECT CEQA IMPACTS AND SIGNIFICANCE

DIRECT IMPACTS

CEQA guidelines §15358 define a “direct impact or primary effect” as “effects which are caused by the project and occur at the same time and place” that can produce a temporary or permanent biologically significant, “physical change” in the environment.

Vegetation Community Direct Impacts

The proposed Torrey Pines Slope Restoration Project consists of the replacement of the existing deteriorated/failed shotcrete wall, stabilization of the slope, and installation a new soil nail wall that is required to prevent further erosion. The project proposes to remove the existing gunite wall, and replace in place with a new soil nail wall with boulder-scape wall face. Replacement of the wall will largely be in the same footprint of the existing deteriorating wall, but construction will require the removal of surrounding and encroaching non-native vegetation that is currently present in the area.

The designated staging area located immediately north of Torrey Pines Road would be temporarily impacted as a result of the project. Impacts however would be restricted to the trampling of non-native vegetation and trimming of eucalyptus, Brazilian pepper, and Peruvian pepper trees required for access and staging.

The proposed Torrey Pines Slope Restoration Project would result in permanent and/or temporary impacts to non-native vegetation and urban/developed lands (Tier IV habitats) as a result of the construction of the new soil nail wall and the temporary establishment of the adjacent staging area (Table 4, Figure2).

Based on the City’s Significance Determination Guidelines Under CEQA, revised version (2011), impacts to Tier IV habitats ((i.e., non-native vegetation and urban/developed) are not considered to have significant habitat value and impacts would not be considered significant.

Table 4. Quantitative Summary of Vegetation Community Impacts within the Project Study Area

Vegetation Community	MSCP Upland Tier Habitat Type	Existing (acres)	Impacts (acres)	Applicable Mitigation Requirement
Non-native Vegetation	IV	1.76	0.45 (0.30 acre for soil nail wall; 0.15 acre for staging area)	n/a
Urban/Developed	IV	1.21	0.00	n/a
Total:		2.98	0.45	

Sensitive Species Direct Impacts

Although several Torrey pine trees occur within the project study area, it is presumed that they were originally planted as part of the urban landscape and are not afforded the same protection under the MSCP as the native population of Torrey Pines located within the Torrey Pines State Reserve. Construction of the new soil nail wall may directly impact one large Torrey pine that is located in close proximity to the impact area (Figure 2). Since this Torrey Pine tree does not occur within the Torrey Pines State Reserve (native population) and is likely planted as a landscape tree, impacts to this tree would not be considered significant under CEQA. Nonetheless, impacts to this tree in the form of trimming activities are proposed to be avoided, where practicable. If tree impacts can not be avoided, then trimming activities should be performed by a Certified Arborist and shall be completed per ANSI A 300 Standards.

No other sensitive flora species were identified or have at least a moderate potential to occur within the project study area.

No sensitive fauna species were observed or detected during the recent biology survey, however, potential impacts to sensitive fauna species with at least a moderate potential to occur on-site (i.e., monarch butterfly, Cooper’s hawk) could occur during project construction. Due to the small scale

of the project and lack of monarch host plant (i.e., milkweed) onsite, it is not expected that implementation of the project would have a substantial adverse effect on the monarch and thus, would not be considered significant under CEQA.

On the contrary, Cooper's hawk may potentially nest within the mature trees onsite where the proposed construction may result in a direct impact on an active Cooper's hawk nest and thus, would be significant under CEQA. Project Mitigation Measures 1-2 would reduce this biological significant impact to a level below significance and ensure conformance with CEQA, the City MSCP Subarea Plan, and City Biology Guidelines.

Wildlife Corridor Direct Impacts

No wildlife corridor occurs onsite or in proximity to the project site, therefore impacts that result from the project would not impact a wildlife corridor or substantially alter the movement of wildlife in the region; therefore, potential impacts resulting from the project would not be considered significant under CEQA.

INDIRECT IMPACTS

CEQA guidelines §15358 define an "indirect impact or secondary effect" as "effects which are caused by the project and are later in time or farther removed in distance, but are still reasonably foreseeable" that can produce a temporary or permanent biologically significant, "physical change" in the environment.

The proposed disturbance and clearing of vegetation required for the project could result in potential soil erosion/runoff and conditions suitable for additional non-native, weedy species that may invade within and adjacent to the project area. Project Mitigation Measures 2-3 would reduce this biological significant impact to a level below significance and ensure conformance with CEQA, the City MSCP Subarea Plan, and City Biology Guidelines.

MSCP Consistency and Land Use Directives

The proposed Torrey Pines Slope Restoration Project is not located within or adjacent to the MHPA, therefore, the MSCP Land Use Considerations, Guidelines, Policies, and Directives are not applicable for this project. Nonetheless, implementation of Project Mitigation Measures 1-3 would ensure consistency with the City's MSCP Subarea Plan.

In addition, it anticipated that the project would not result in the release of toxins, chemicals, petroleum products and other elements that might degrade lands within or outside of the MHPA. The temporary duration of the project is not expected to include the installation of artificial lighting, impact narrow endemic species, or permanently impede wildlife movement. As a result, the Torrey Pines Road Slope Restoration Project would be consistent with development regulations and land use directives outside of the MHPA under the City's current Land Development Code, Biology Guidelines (2001).

Cumulative Impacts

CEQA guidelines §15355 define cumulative impacts as "two or more individual effects which, when considered together, are considerable or which compound or increase other environmental impacts". The MSCP was designed to compensate for the loss of biological resources throughout the program's

region; therefore, projects that conform to the MSCP would not result in a cumulatively considerable impact for those biological resources adequately covered by the program. The aforementioned direct and indirect impacts resulting from the proposed project would therefore not be cumulatively considerable if the project mitigation measures are implemented to ensure conformance to the MSCP Subarea Plan and Biology Guidelines.

PROJECT IMPACTS UNDER THE MIGRATORY BIRD TREATY ACT (MBTA)/CDFG CODE

Under the MBTA, it is unlawful, except as permitted by the USFWS, to “take, possess, transport, sell, purchase, barter, import, or export all species of birds protected by the MBTA, as well as their feathers, parts, nests, or eggs. Take means to pursue, hunt, shoot, wound, kill, trap, capture, or collect, or attempt to pursue, hunt, shoot, wound, kill, trap, capture, or collect (50 CFR 10.12).” It is important to note that “take” as defined under the federal MBTA is not synonymous with “take” as defined under the federal ESA. The MBTA definition of “take” lacks a “harm and harassment” clause comparable to “take” under the ESA, thus, the MBTA authority does not extend to activities beyond the nests, eggs, feathers, or specific bird parts (i.e., activities or habitat modification in the vicinity of nesting birds that do not result in “take” as defined under the MBTA are not prohibited).

Sections 3503, 3503.5, and 3513 of the California Fish and Game Code prohibit the “take, possession, or destruction of bird nests or eggs.” Section 3503 states: “It is unlawful to take, possess, or needlessly destroy the nest or eggs of any bird, except as otherwise provided by this code or any regulation made pursuant thereto.” Section 3513 states: “It is unlawful to take or possess any migratory nongame bird as designated in the MBTA or any part of such migratory nongame bird except as provided by rules and regulations adopted by the Secretary of the Interior under provisions of the Migratory Bird Treaty Act.”

The project site has the potential to be utilized by regionally common migratory birds and raptors that are not designated as special status species under CEQA, but are protected under the federal Migratory Bird Treaty Act (MBTA) and CDFG Code Sections 3503 and 3513. Although no active avian nests were observed during our recent biological survey, avian species could potentially nest in the onsite habitats and the proposed project could result in direct impacts to active bird and/or raptor nests under the federal MBTA and/or CDFG Code Sections 3503 and 3513. Project Mitigation Measure 1 would reduce this biological significant impact to a level below significance and ensure conformance with CEQA, the City MSCP Subarea Plan, and City Biology Guidelines.

MITIGATION AND MONITORING REQUIREMENTS

CEQA Guidelines §15370 (Title 14, Chapter 3, Article 20) defines “mitigation” as:

- “Avoiding the impact altogether by not taking a certain action or parts of an action.”
- “Minimizing impacts by limiting the degree or magnitude of the action and its implementation.”
- “Rectifying the impact by repairing, rehabilitating, or restoring the impacted environment.”
- “Reducing or eliminating the impact over time by preservation and maintenance operations during the life of the action.”
- “Compensating for the impact by replacing or providing substitute resources or environments.”

According to the City of San Diego’s Significance Determination Guidelines under the California Environmental Quality Act (1998, revised July 2002), non-native vegetation is not considered to have significant habitat value and impacts would not be considered significant under CEQA;

therefore, mitigation would not be required following the implementation of the Torrey Pines Road Slope Repair Project. Implementation of the following project mitigation measures would reduce potential biological impacts to a level below significance under CEQA, ensure conformance to the City MSCP Subarea Plan and City of San Diego Biology Guidelines, as well as compliance with the federal MBTA and CDFG Code Sections 3503 and 3513.

1. To avoid potential significant impacts to an active nest of a migratory bird (including raptors), no brushing, clearing, and/or grading would be allowed within potential nesting habitat proposed to be impacted during the migratory avian and raptor breeding season (generally defined as January 15th through September 15th) to ensure compliance with the MBTA. If construction would occur within the avian and raptor breeding season, a pre-construction survey for active raptor and migratory bird nests should be conducted within approximately 48 hours prior to the start of construction. The results of the survey should be submitted to the City in the form of a written report, and should include the date(s) of the survey, the name(s) of the investigator(s), the total field time of the survey efforts, a description of the survey area(s), and if any active nests were found. If an active bird nest were found, then all construction activities undertaken for the project shall comply with the regulatory requirements of the federal MTBA and CDFG Codes Sections 3503 and 3513.
2. It is recommended that a monitoring biologist be onsite during the initial clearing of vegetation/habitat to ensure compliance with all mitigation measures and applicable construction best management practices (BMPs). The biologist must be knowledgeable of upland biology and ecology.
3. All disturbed, graded, and/or cleared areas that will not be permanently paved or covered by structures shall be revegetated within 90 days of the completion of disturbance, with native or naturalized plant species to provide erosion control and prevent the establishment of invasive non-native species. It is recommended that a qualified biologist monitor the project revegetation/restoration efforts.

PERMITTING REQUIREMENTS

No resource agency permits are anticipated to be necessary for implementation of the proposed project due to the lack of regulated jurisdictional resources such as wetlands onsite and/or adjacent to the site.

REFERENCES

- Air Photo USA (aka Digital Globe). 2007. Aerial Imagery [Internet]. Available from: <http://www.digitalglobe.com/>.
- American Ornithologists' Union, et al. 1998. Check-list of North American Birds, 7th ed. American Ornithologists' Union, Washington D.C.
- _____. 2010. Fifty-first Supplement to the American Ornithologists' Union *Check-list of North American Birds* [Internet]. Auk 127(3):726-744. Available from: <http://www.aou.org/>.
- Bing Maps (Microsoft Corporation). 2010. Aerial Imagery.
- California Department of Fish and Game. 2010. Life History Accounts and Range Maps [Internet]. California Wildlife Habitat Relationships System. Edited by Zeiner DC, et al. 1988-1990, updated. Available from: <http://www.dfg.ca.gov/biogeodata/cwhr/cawildlife.aspx>.
- _____. 2011a. State and Federally Listed Endangered & Threatened Animals of California [Internet]. Natural Diversity Database. 13 pp. Available from: <http://www.dfg.ca.gov/biogeodata/cnddb/pdfs/TEAnimals.pdf>.
- _____. 2011b. Special Animals [Internet]. Natural Diversity Database. 50 pp + Endnotes. Available from: <http://www.dfg.ca.gov/biogeodata/cnddb/pdfs/SPAnimals.pdf>.
- _____. 2012aa. California Natural Diversity Database (CNDDDB). Biogeographic Data Branch. RareFind 3; GIS shapefile update CD, January 2012. Sacramento, California.
- _____. 2012b. State and Federally Listed Endangered & Threatened Plants of California [Internet]. Natural Diversity Database. 13 pp. Available from: <http://www.dfg.ca.gov/biogeodata/cnddb/pdfs/TEPlants.pdf>
- _____. 2012c. Special Plants [Internet]. Natural Diversity Database. 50 pp + Endnotes. Available from: <http://www.dfg.ca.gov/biogeodata/cnddb/pdfs/SPPlants.pdf>
- _____. 2010. Life History Accounts and Range Maps [Internet]. California Wildlife Habitat Relationships System. Edited by Zeiner DC, et al. 1988-1990, updated. Available from: <http://www.dfg.ca.gov/biogeodata/cwhr/cawildlife.aspx>.
- California Native Plant Society (CNPS). 2010. Inventory of Rare and Endangered Plants (on-line edition, v7-10a) [Internet]. California Native Plant Society. Sacramento, CA. Available from: <http://www.cnps.org/inventory>.
- City of San Diego. 1997. City of San Diego Multiple Species Conservation Program (MSCP) Subarea Plan [Internet]. Prepared by the City of San Diego Community and Economic Development Department. 109 pp. + Appendix. Available from: <http://www.sandiego.gov/planning/mscp/pdf/subareafullversion.pdf>.
- _____. 2001. San Diego Municipal Code: Land Development Code, Biology Guidelines [Internet]. Adopted 1999, Amended 2000, 2001. 34 pp. + Attachments A and B. Available from: <http://www.sandiego.gov/mscp/pdf/biolog.pdf>.

- _____. 2002. Guidelines for Conducting Biological Surveys [Internet]. 1998, Revised 2002. 14 pp + Attachments I-V. Available from: <http://www.sandiego.gov/mscp/pdf/biosurvey.pdf>.
- _____. 2011, Revised 1991, 1994, 1999, 2001, 2004, 2006, and 2007. California Environmental Quality Act Significance Determination Thresholds [Internet]. Development Services Department. 83 pp. Available from: <http://www.sandiego.gov/development-services/news/pdf/sdtceqa.pdf>.
- Crother BI (ed.). 2000 (2001). Scientific and Standard English Names of Amphibians and Reptiles of North America North of Mexico, with Comments Regarding Confidence in Our Understanding. SSAR Herpetological Circular 29.iii +82 pp.
- Crother BI, Boundy J, Campbell JA, De Quieroz K, Frost D, Green DM, Highton R, Iverson JB, McDiarmid RW, Meylan PA, Reeder TW, Seidel ME, Sites JW Jr., Tilley SG, Wake DB. 2003. Scientific and Standard English Names of Amphibians and Reptiles of North America North of Mexico: Update. Herpetological Review 2003, 34(3), 196-203.
- Hall ER. 1981. The mammals of North America. 2nd Edition. John Wiley & Sons. New York, New York. Two volumes. 1,181 pp. Holland RF. 1986. Preliminary Descriptions of the Terrestrial Natural Communities of California. Nongame-Heritage Program, State of California, Resources Agency, Department of Fish and Game. Sacramento, California. 157pp.
- Klein MW, San Diego Natural History Museum. 2002. Butterflies of San Diego County [Internet]. Available from: <http://www.sdnhm.org/research/entomology/sdbutterflies.html>.
- National Water and Climate Data Center (USDA-NRCS 2002). USDA-NRCS. Available from: <http://www.wcc.nrcs.usda.gov/climate/wetlands.html>.
- Natural Resource Conservation Service. 2010. National Soils List by State (California). Available from: <http://soils.usda.gov/use/hydric/lists/state.html>.
- Oberbauer T, Kelly M, Buegge J. 2008, Revised 1996 and 2006. Draft Vegetation Communities of San Diego County [Internet]. Based on "Preliminary Descriptions of the Terrestrial Natural Communities of California", Holland RF, PhD., 1986. Available from: http://www.sdcounty.ca.gov/dplu/docs/Veg_Comm_SDCounty_2008.pdf.
- Opler PA, Lotts K., Naberhaus T. coordinators. 2010. Butterflies and Moths of North America [Internet]. Bozeman, MT: Big Sky Institute. Available from: <http://www.butterfliesandmoths.org/>.
- Rebman JP, Simpson MG. 2006. Checklist of the Vascular Plants of San Diego County, 4th Edition [Internet]. ISBN 0-918969-05-0. Available from: <http://www.sdnhm.org/research/botany/sdplants/index.html>.
- Reiser, Craig H. 1994. Rare Plants of San Diego County. Available from: <http://sandiego.sierraclub.org/rareplants/>.
- San Diego Geographic Information Source (SanGIS). 2010. Ecology, Vegetation Download (zip) updated 4/9/2007 [Internet]. Available from: <http://www.sangis.org/>

- Stebbins, RC. 2003. Peterson Field Guide: Western Reptiles and Amphibians. 3rd Edition.
- United States Department of Agriculture. 1973. Soil Survey of the San Diego Area, California, Part I. December, 1973.
- _____. 2007. Soil Survey Geographic (SSURGO) database for San Diego County, California [Internet]. Natural Resources Conservation Service (NRCS). Available from: <http://SoilDataMart.nrcs.usda.gov/>.
- U.S. Fish and Wildlife Service (USFWS), Carlsbad Fish and Wildlife Office (CFWO). GIS Division Species Occurrence Data Download (zip) updated . September 2011. <http://www.fws.gov/carlsbad/giswebpage/giswebpage.htm>
- U.S. Geological Survey (USGS). 2005. Preliminary Integrated Geological Map Databases for the United States; Western States: California, Nevada, Arizona, Washington, Oregon, Idaho, and Utah. Version 1.2. GIS Data Download California (zip) [Internet]. Available from: <http://pubs.usgs.gov/of/2005/1305/#CA>.
- Wilson DE, Reeder DM (eds). 2005. Mammal Species of the World. Johns Hopkins University Press. 2,142 pp. Available from Johns Hopkins University Press at: 1-800-537-5487 or (410) 516-6900, or <http://www.press.jhu.edu/> or <http://nmnhgoph.si.edu/msw/>.

APPENDIX 1. FLORA SPECIES OBSERVED ON-SITE

All species located in areas mapped as Non-native Vegetation

* = Denotes non-native flora species.

Scientific Name	Common Name
-----------------	-------------

GYMNOSPERMS**Pinaceae - Pine Family***Pinus torreyana* Carrière

Torrey pine

**Pinus radiata*

Monterey pine

**Pinus* sp.

Pine

Podocarpaceae - Podocarpus Family**Podocarpus* sp.

podocarpus

DICOTYLEDONS**Aizoaceae – Fig-Marigold Family****Carpobrotus chilensis* (Molina) N. E. Br.

sea fig

**Carpobrotus edulis* (L.) N. E. Br.

hottentot-fig

Amaranthaceae - Amaranth Family**Atriplex semibaccata* R. Br.

Australian saltbush

**Salsola tragus* L.

Russian thistle, tumbleweed

Anacardiaceae - Sumac Family*Rhus integrifolia* (Nutt.) Brewer & S. Watson

lemonadeberry

**Schinus molle* L.

Peruvian pepper tree

**Schinus terebinthifolius* Raddi

Brazilian pepper tree

Apiaceae - Carrot Family**Foeniculum vulgare* Miller

fennel

Apocynaceae - Dogbane Family**Nerium oleander* L.

oleander

Araliaceae – Ginseng Family**Hedera canariensis* Willd.

Algerian Ivy

Asteraceae - Sunflower Family**Sonchus asper* (L.) Hill ssp. *asper*

prickly sow thistle

**Sonchus oleraceus* L.

common sow thistle

Bignoniaceae - Bignonia Family**Tecoma capensis*

cape honeysuckle

Brassicaceae - Mustard Family**Hirschfeldia incana* (L.) Lagr.-Fossat

short-pod mustard

**Raphanus sativus* L.

wild radish

Scientific Name	Common Name
Cactaceae - Cactus Family * <i>Opuntia ficus-indica</i> (L.) Miller	mission prickly pear, Indian-fig
Crassulaceae - Stonecrop Family * <i>Crassula argentea</i> Thunb.	jade plant
Fabaceae - Pea Family * <i>Acacia</i> sp.	acacia
Myrtaceae - Myrtle Family * <i>Eucalyptus</i> sp.	eucalyptus
Pittosporaceae – Pittosporum Family <i>Pittosporum undulatum</i> Vent.	Victoria-box
Rosaceae - Rose Family <i>Heteromeles arbutifolia</i> (Lindley) M. Roemer	toyon, Christmas berry
Scrophulariaceae - Figwort Family * <i>Myoporum laetum</i> Forster f.	Ngaio, mousehold tree
Solanaceae - Nightshade Family * <i>Nicotiana glauca</i> Graham	tree tobacco
Tropaeolaceae - Nasturtium Family * <i>Tropaeolum majus</i> L.	garden nasturtium
MONOCOTYLEDONS	
Agavaceae – Agave Family * <i>Agave americana</i> L. * <i>Yucca elephantipes</i>	American agave American agave
Poaceae - Grass Family * <i>Avena barbata</i> * <i>Bambusa</i> sp. * <i>Bromus madritensis</i> L. ssp. <i>rubens</i> (L.) Husnot * <i>Cynodon dactylon</i> (L.) Pers. * <i>Ehrharta erecta</i> Lam.	slender wild oat bamboo red brome, foxtail chess Bermuda grass panic veldt grass

APPENDIX 2. FAUNA SPECIES OBSERVED OR DETECTED ON-SITE

Habitat Types:

All species located in areas mapped as Non-native Vegetation

* = denotes introduced species

Abundance Codes (birds only):

A = Abundant: Almost always encountered in moderate to large numbers in suitable habitat and the indicated season.

C = Common: Usually encountered in proper habitat at the given season.

U = Uncommon: Infrequently detected in suitable habitat. May occur in small numbers or only locally in the given season.

R = Rare: Applies to species that are found in very low numbers.

“Numbers” indicate the number of individuals observed during the field survey work.

Status Codes (birds only):

M = Migrant: Uses the site for brief periods of time, primarily during the spring and fall months.

R = Year-round resident: Probable breeder on-site or in the vicinity.

S = Spring/summer resident: Probable breeder on-site or in the vicinity unless combined with transient status.

T = Transient: Uses site irregularly in summer but unlikely to breed. Not a true migrant and actual status often poorly known.

W = Winter visitor: Does not breed locally.

V = Casual vagrant: Not expected; out of normal geographic or seasonal range and by definition rare.

BUTTERFLIES**Papilionidae (Swallowtails)**

pale swallowtail *Papilio eurymedon*

REPTILES**Phrynosomatidae**

western fence lizard *Sceloporus occidentalis*

BIRDS**Laridae (Gulls and Terns)**

western gull *Larus occidentalis* A R, T

Columbidae (Pigeons and Doves)

mourning dove *Zenaida macroura* C R

Trochilidae (Hummingbirds)

Anna's hummingbird *Calypte anna* C R

Mimidae (Mockingbirds and Thrashers)

northern mockingbird *Mimus polyglottos* C R

Emberizidae (Sparrows, Blackbirds and Relatives)

song sparrow *Melospiza melodia* A R

Fringillidae (Finches)

lesser goldfinch *Spinus psaltria* C M, R

MAMMALS**Sciuridae (Squirrels)**

California ground squirrel *Spermophilus beecheyi nudipes*

APPENDIX K

SAMPLE OF PUBLIC NOTICES

FOR SAMPLE REFERENCE ONLY



CONSTRUCTION NOTICE

PROJECT TITLE

Work on your street will begin within one week to replace the existing water mains servicing your community.

The work will consist of:

- Saw-cutting and trench work on Ingulf Street from Morena Boulevard to Galveston Street to install new water mains, water laterals and fire hydrants.
- Streets where trenching takes place will be resurfaced and curb ramps will be upgraded to facilitate access for persons with disabilities where required.
- This work is anticipated to be complete in your community by December 2016.

How your neighborhood may be impacted:

- Water service to some properties during construction will be provided by a two-inch highline pipe that will run along the curb. To report a highline leak call 619-515-3525.
- Temporary water service disruptions are planned. If planned disruptions impact your property, you will receive advance notice.
- Parking restrictions will exist because of the presence of construction equipment and materials.
- "No Parking" signs will be displayed 72 hours in advance of the work.
- Cars parked in violation of signs will be TOWED.

Hours and Days of Operation:

Monday through Friday X:XX AM to X:XX PM.

City of San Diego Contractor:

Company Name, XXX-XXX-XXXX



CONSTRUCTION NOTICE

PROJECT TITLE

Work on your street will begin within one week to replace the existing water mains servicing your community.

The work will consist of:

- Saw-cutting and trench work on Ingulf Street from Morena Boulevard to Galveston Street to install new water mains, water laterals and fire hydrants.
- Streets where trenching takes place will be resurfaced and curb ramps will be upgraded to facilitate access for persons with disabilities where required.
- This work is anticipated to be complete in your community by December 2016.

How your neighborhood may be impacted:

- Water service to some properties during construction will be provided by a two-inch highline pipe that will run along the curb. To report a highline leak call 619-515-3525.
- Temporary water service disruptions are planned. If planned disruptions impact your property, you will receive advance notice.
- Parking restrictions will exist because of the presence of construction equipment and materials.
- "No Parking" signs will be displayed 72 hours in advance of the work.
- Cars parked in violation of signs will be TOWED.

Hours and Days of Operation:

Monday through Friday X:XX AM to X:XX PM.

City of San Diego Contractor:

Company Name, XXX-XXX-XXXX

To contact the City of San Diego: Public Works
619-533-4207 | engineering@sandiego.gov | sandiego.gov/CIP

To contact the City of San Diego: Public Works
619-533-4207 | engineering@sandiego.gov | sandiego.gov/CIP

APPENDIX L

ADVANCED METERING INFRASTRUCTURE (AMI) DEVICE PROTECTION

Protecting AMI Devices in Meter Boxes and on Street Lights

The Public Utilities Department (PUD) has begun the installation of the Advanced Metering Infrastructure (AMI) technology as a new tool to enhance water meter reading accuracy and efficiency, customer service and billing, and to be used by individual accounts to better manage the efficient use of water. **All AMI devices shall be protected per Section 5-2, "Protection", of the 2015 Whitebook.**

AMI technology allows water meters to be read electronically rather than through direct visual inspection by PUD field staff. This will assist PUD staff and customers in managing unusual consumption patterns which could indicate leaks or meter tampering on a customer's property.

Three of the main components of an AMI system are the:

- A. Endpoints, see Photo 1:

Photo 1

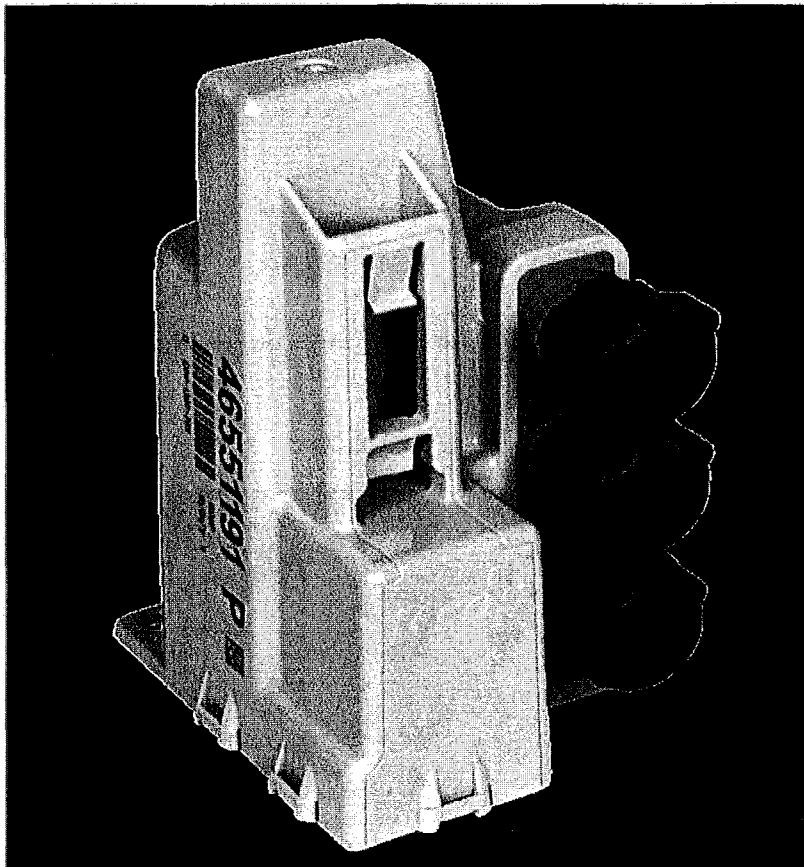

B. AMI Antenna attached to Endpoint (antenna not always required), see Photo 2:

Photo 2

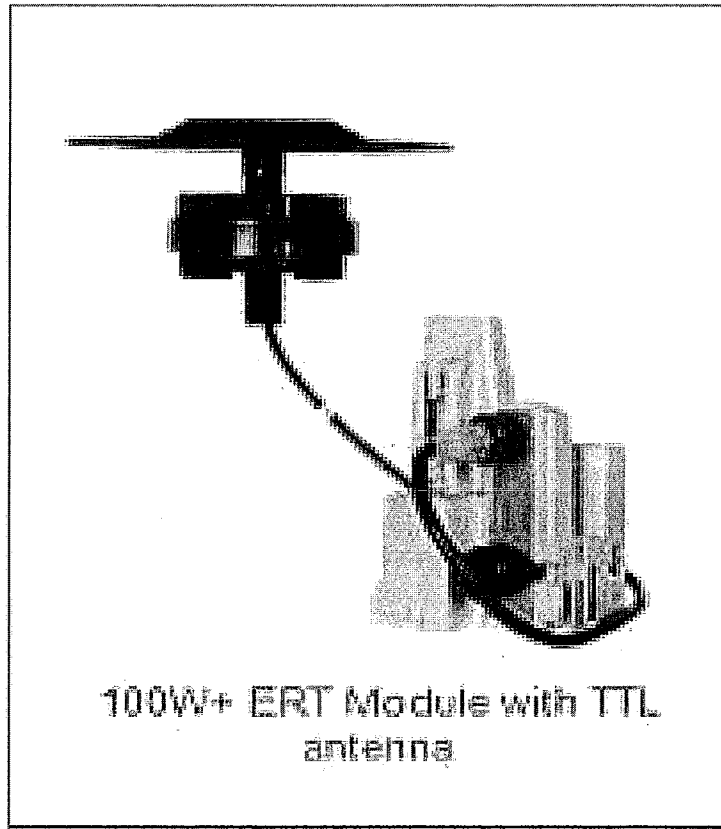

Network Devices, see Photo 3:

Photo 3

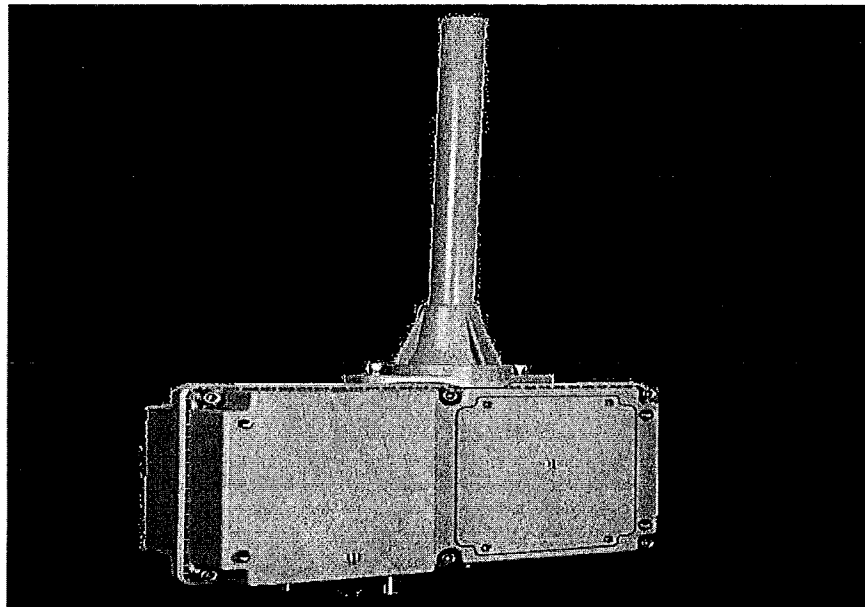

AMI endpoints transmit meter information to the AMI system and will soon be on the vast majority of meters in San Diego. These AMI devices provide interval consumption data to the PUD's Customer Support Division. If these devices are damaged or communication is interrupted, this Division will be alerted of the situation. The endpoints are installed in water meter boxes, coffins, and vaults adjacent to the meter. A separate flat round antenna may also be installed through the meter box lid. This antenna is connected to the endpoint via cable. The following proper installation shall be implemented when removing the lid to avoid damaging the antenna, cable, and/or endpoint. Photo 4 below demonstrates a diagram of the connection:

Photo 4

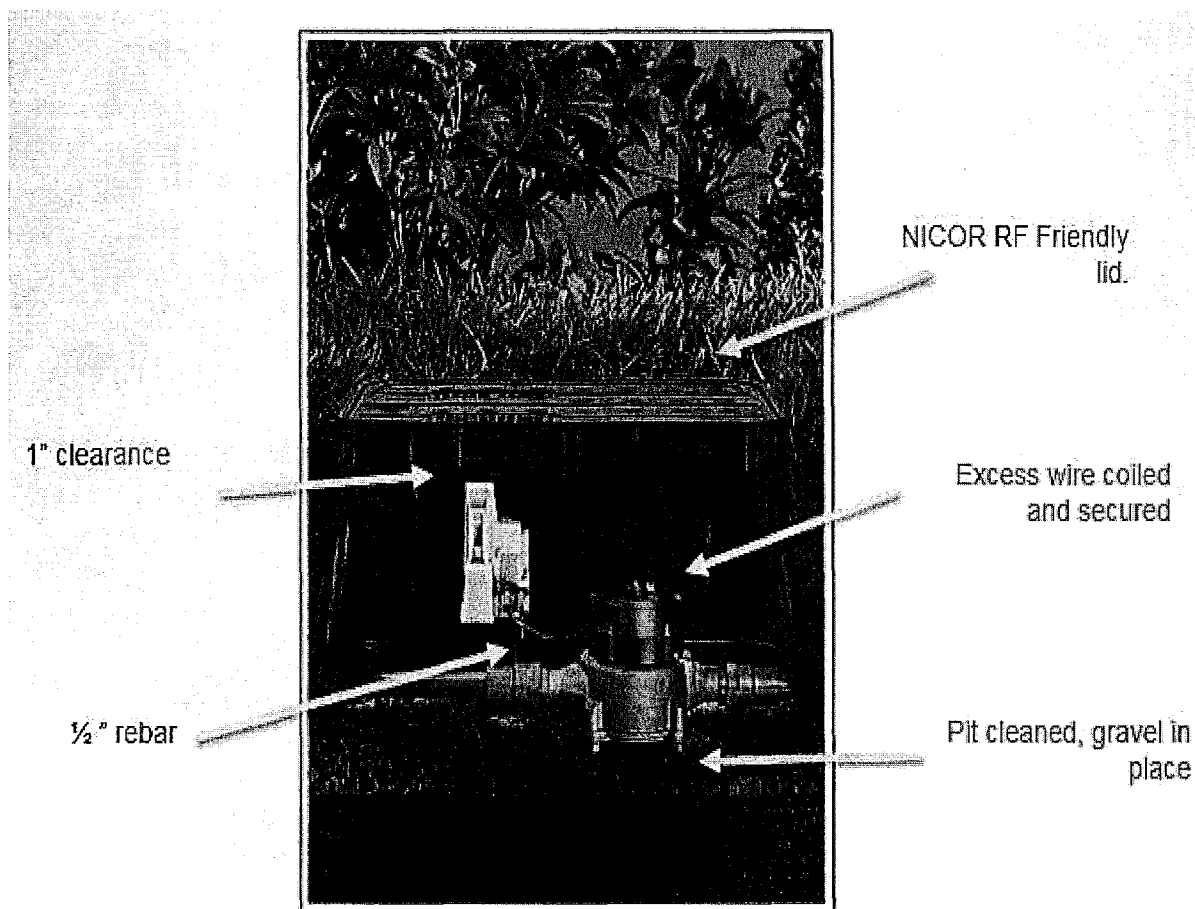

The AMI device ERT/Endpoint/Transmitter shall be positioned and installed as discussed in this Appendix. If the ERT/Endpoint/Transmitter is disturbed, it shall be re-installed and returned to its original installation with the end points pointed upwards as shown below in Photo 5.

The PUD's code compliance staff will issue citations and invoices to you for any damaged AMI devices that are not re-installed as discussed in the Contract Document

Photo 5 below shows a typical installation of an AMI endpoint on a water meter.

Photo 5

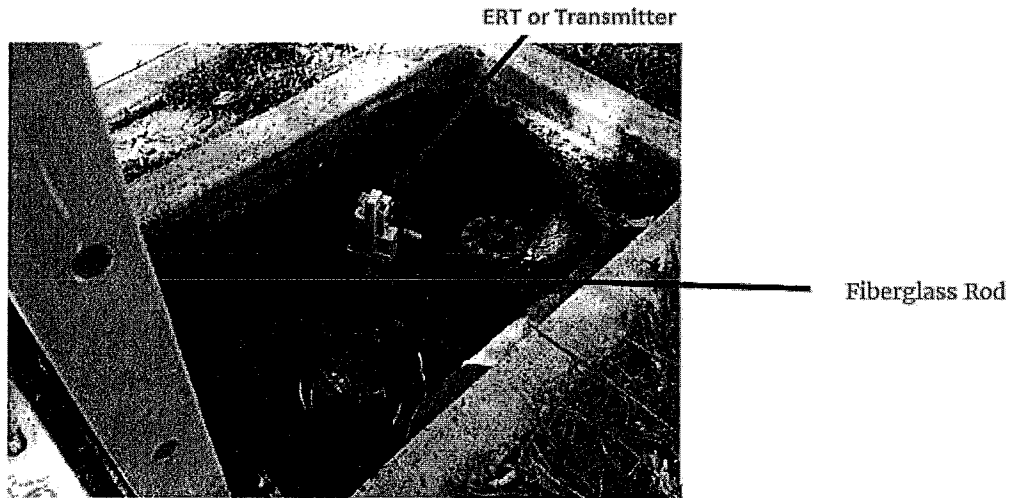
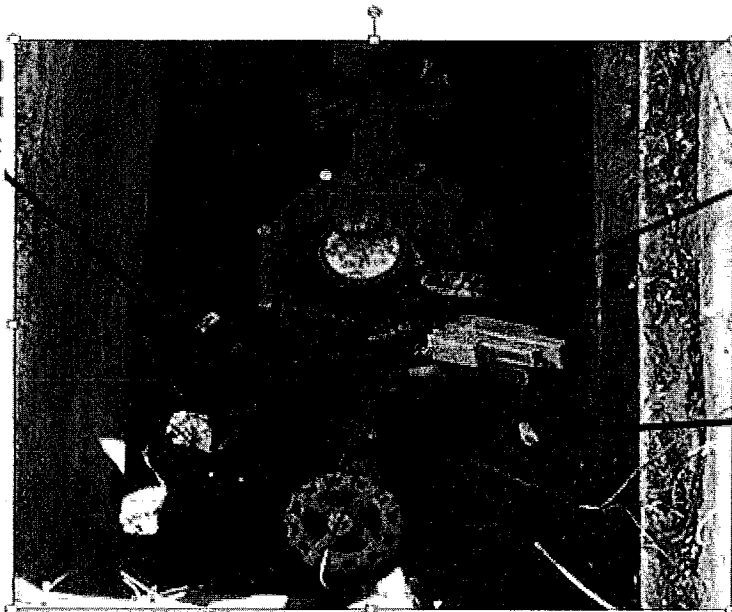

Photo 6 below is an example of disturbance that shall be avoided:

Photo 6

The antenna was drilled into the lid and now it is removed



You are responsible when working in and around meter boxes. If you encounter these endpoints, use proper care and do not disconnect them from the registers on top of the water meter. If the lid has an antenna drilled through, do not change or tamper with the lid and inform the Resident Engineer immediately about the location of that lid. Refer to Photo 7 below:

Photo 7



Another component of the AMI system are the Network Devices. The Network Devices are strategically placed units (mainly on street light poles) that collect interval meter reading data from multiple meters for transmission to the Department Control Computer. **If you come across any of these devices on street lights that will be removed or replaced (refer to Photos 8 and 9 below), notify AMI Project Manager Arwa Sayed at (619) 362-0121 immediately.**

Photo 8 shows an installed network device on a street light. On the back of each Network Device is a sticker with contact information. See Photo 9. **Call PUD Water Emergency Repairs at 619-515-3525 if your work will impact these street lights.** These are assets that belong to the City of San Diego and you shall be responsible for any costs of disruption of this network.

Photo 8

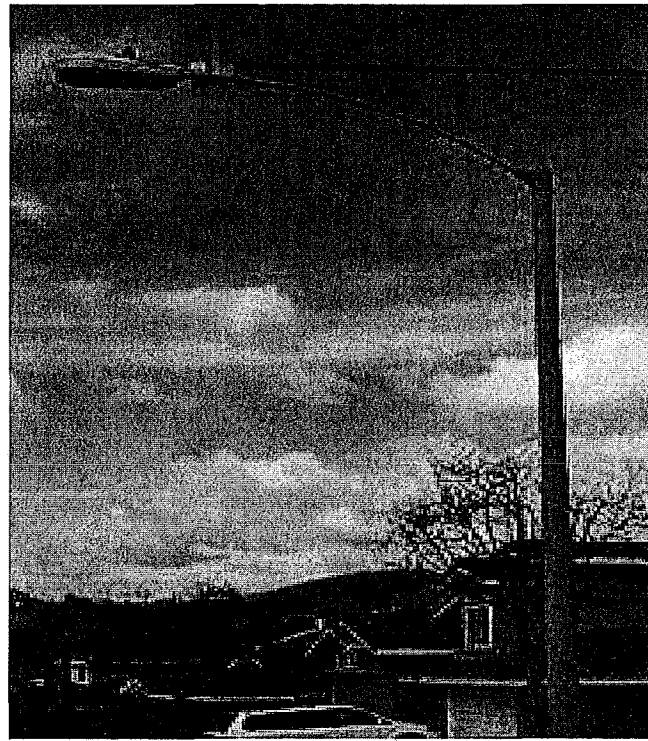

Network Device

Photo 9

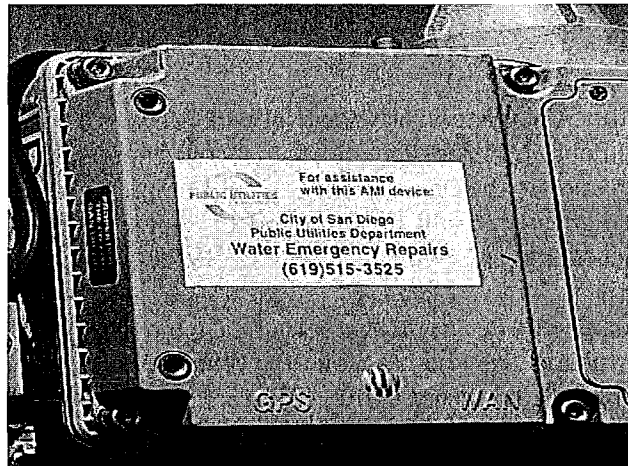

If you encounter any bad installations, disconnected/broken/buried endpoints, or inadvertently damage any AMI devices or cables, notify the Resident Engineer immediately. The Resident Engineer will then immediately contact the AMI Project Manager, Arwa Sayed, at (619) 362-0121.

APPENDIX M

ARCHAEOLOGICAL REPORT



LSA ASSOCIATES, INC.
703 PALOMAR AIRPORT ROAD
SUITE 260
CARLSBAD, CALIFORNIA 92011

760.931.5471 TEL
760.918.2458 FAX

BERKELEY
FRESNO
IRVINE

PALM SPRINGS
PT. RICHMOND
RIVERSIDE

ROCKLIN
SAN LUIS OBISPO

July 8, 2016

Brad Johnson
City of San Diego
Public Works Department - Engineering and Capital Projects
1010 Second Avenue, Suite 1200
San Diego, California 92101

Subject: Results of Auger Testing for Torrey Pines Road Improvements, Phase II Project (LSA Project No. RKE1602)

Dear Mr. Johnson:

We are pleased to inform you that LSA Associates, Inc. (LSA) has completed the auger testing investigation for the Torrey Pines Road Improvements, Phase II Project. LSA Archaeologist Roderic McLean served as the Principal Investigator during this work, and his qualifications as an archaeologist exceed the professional qualifications required by the City. LSA contracted with Misschief Cultural Monitoring, Inc. to provide a Native American monitor who was present during all fieldwork for this project. This letter provides a summary of the methods and results for the archaeological auger testing of the Torrey Pines Road Improvements, Phase II Project.

OVERVIEW

The Torrey Pines Road Improvements, Phase II Project proposes to install two High Intensity Activated Cross Walk Beacon (HAWK) poles on the north and south side of Torrey Pines Road near Princess Street (attached Figures 1 and 2). These locations are adjacent to the previously recorded site boundary for Site CA-SDI-39, a prehistoric/ethnohistoric village site. Prior to development, this area encompassed a large habitation area known as Mut kula xuy/Mut lah hoy ya meaning “the place of many caves” (Christenson 1998). It is also known as the Spindrift Site (Rogers 1926). The Spindrift Site is considered significant because it represents a large village site that has yielded thousands of artifacts and human remains. Although Torrey Pines Road has been graded, there is potential to encounter Holocene-age deposits as construction of Torrey Pines Road may not have removed all deposits dating to the last 10,000 years. Auger testing was conducted at the proposed beacon pole locations to determine the potential for subsurface cultural deposits.

ARCHAEOLOGICAL AUGER TESTING FIELD METHODS

LSA hand excavated at the two proposed beacon pole locations on the north and south side of Torrey Pines Road (Photographs 1 and 2), near Princess Street on June 23, 2016 (refer again to attached Figures 1 and 2). Hand excavation consisted of placing auger holes in the proposed beacon pole areas. The hand auger is a 6 ½ -inch tall 3-inch diameter drill bucket. The portion of sidewalk covering the beacon pole locations was removed prior to excavation, then patched using Quikrete Vinyl Concrete Patcher. All soil was screened through a ¼-inch mesh screen. Soil type was noted every 20 centimeters. LSA staff for this project included Project Manager/Principal Investigator Roderic McLean, RPA, Christopher Morgan, RPA, and Jacqueline Hall, all of whom are certified by the City. Mike Trotta served as the Principal in Charge and provided project oversight and quality control.

(7/8/2016) P:\RKE1602 - Torrey Pines Rd Phase 2\Letter_Report\RKE1602LetterRpt.docx

PLANNING

ENVIRONMENTAL SCIENCES

DESIGN

LSA also coordinated Native American monitoring with Annette Osuna of Misschief Cultural Monitoring, Inc.

RESULTS

During the course of the auger testing investigation, no cultural resources, including midden/anthrosols, were encountered. Soils observed within the Auger 1 testing location (north side of Torrey Pines Road) appeared to be highly disturbed. Soils within the Auger 2 testing location (south side of Torrey Pines Road) were likely part of the original slope that was modified during the construction of Torrey Pines Road. Table A details the results of auger testing (including Munsell color, textural estimates, and content).

Table A: Results of Auger Testing

Depth (cm below surface)	Auger 1	Auger 2
	North side of Torrey Pines Road	South side of Torrey Pines Road
0-20	10YR 4/3 Brown sandy clay, highly mottled. No cultural resources observed	10 YR 5/4 Yellowish brown sandy silt. No cultural resources observed.
20-40	10YR 4/3 Brown sandy clay, highly mottled. No cultural resources observed	10 YR 5/4 Yellowish brown sandy silt (Photograph 4). No cultural resources observed.
40-60	10YR 4/3 Brown sandy clay, highly mottled. No cultural resources observed	10 YR 5/4 Yellowish brown sandy silt. No cultural resources observed.
60-80	10YR 4/3 Brown sandy clay, moderately mottled. No cultural resources observed	10 YR 5/4 Yellowish brown sandy silt. No cultural resources observed.
80-100	10 YR 5/2 Grayish brown clay (Photograph 3). No cultural resources observed. Terminated at 88 centimeters due to impassable rock.	10 YR 5/4 Yellowish brown sandy silt. No cultural resources observed. Terminated at 92 centimeters due to impassable rock.

CONCLUSIONS AND MANAGEMENT SUMMARY

The purpose of the archaeological auger testing investigation was to determine whether an intact cultural deposit was present at the proposed beacon pole locations. Because the beacon pole locations are adjacent to the previously recorded site boundary for Site CA-SDI-39, the potential for subsurface deposits existed. The auger testing investigation confirmed that Site CA-SDI-39 is not present within the proposed streetlight locations. No cultural resources were identified during auger testing investigation. Soils observed at the Auger 1 testing location were highly disturbed from the construction of Torrey Pines Road. Soils observed at the Auger 2 testing location were likely part of

the original sloped landform that was cut into during the construction of Torrey Pines Road, and were devoid of cultural material. No additional cultural resources efforts are recommended at this time.

Sincerely,

LSA ASSOCIATES, INC.



Roderic McLean, M.A., RPA
Associate/Archaeologist

Attachments: References Cited
 Photographs
 Figure 1: Project Location
 Figure 2: Proposed Beacon Pole and Auger Locations in Relation to Site CA-SDI-39

REFERENCES CITED

Christenson, Lynn

1998 Archaeological History of CA-SDI-39 (Museum of Man #W-1) The Kumeyaay Village of MUT-LLEHUP (Spindrift Site). On file at the SCIC.

Rogers, Malcolm J.

1926 A Preliminary Survey of the La Jolla Finds. Manuscript on file at the San Diego Museum of Man.

PHOTOGRAPHS



Photograph 1: Overview of Auger 1 location, view towards the southwest.



Photograph 2: Overview of Auger 2 location, view towards the southwest.

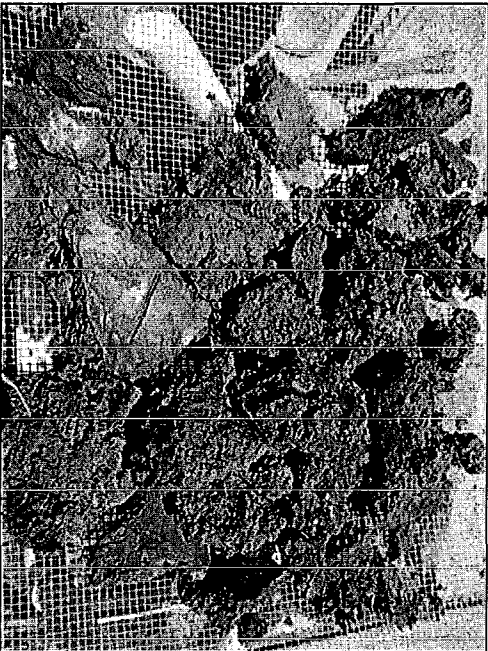

Photograph 3: Close up of soils from Auger 1, 80-88 centimeters below surface

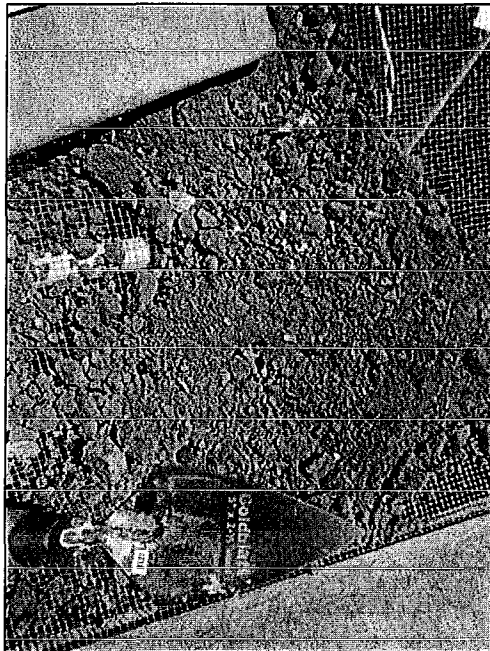

Photograph 4: Close up of soils from Auger 2, 20-40 centimeters below surface.

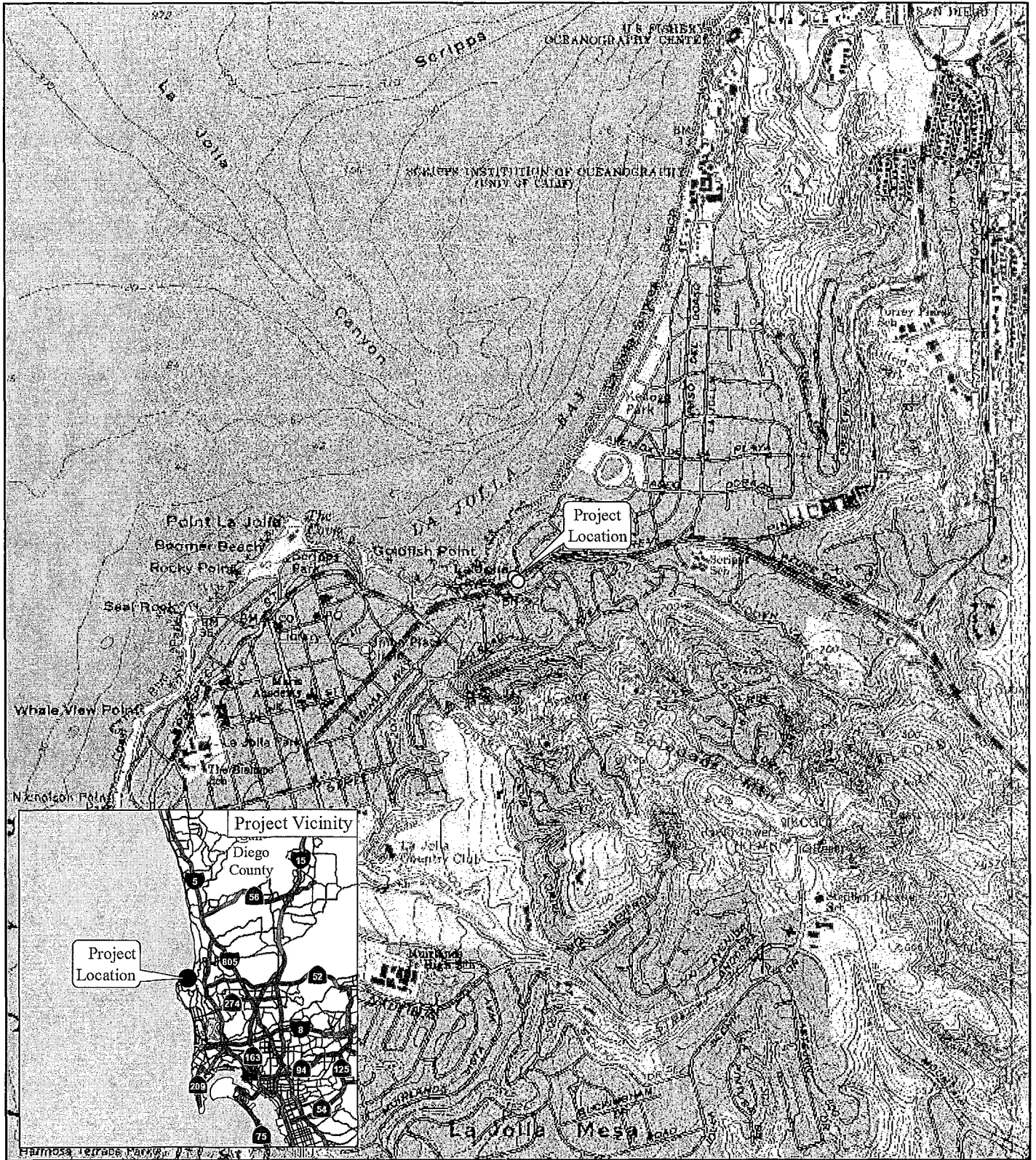

LSA

LEGEND

○ Proposed Beacon Pole Location



0 1000 2000
FEET

SOURCE: USGS 7.5' Quad. (La Jolla, 1975)

\\ARKE1602\GIS\Proj\Loc.mxd (7/8/2016)

Torrey Pines Road Improvements Phase 2 and Torrey Pines Road slope Restoration
Appendix M- Archeological Report

FIGURE 1

Torrey Pines Road Improvements, Phase II Project
Project Location

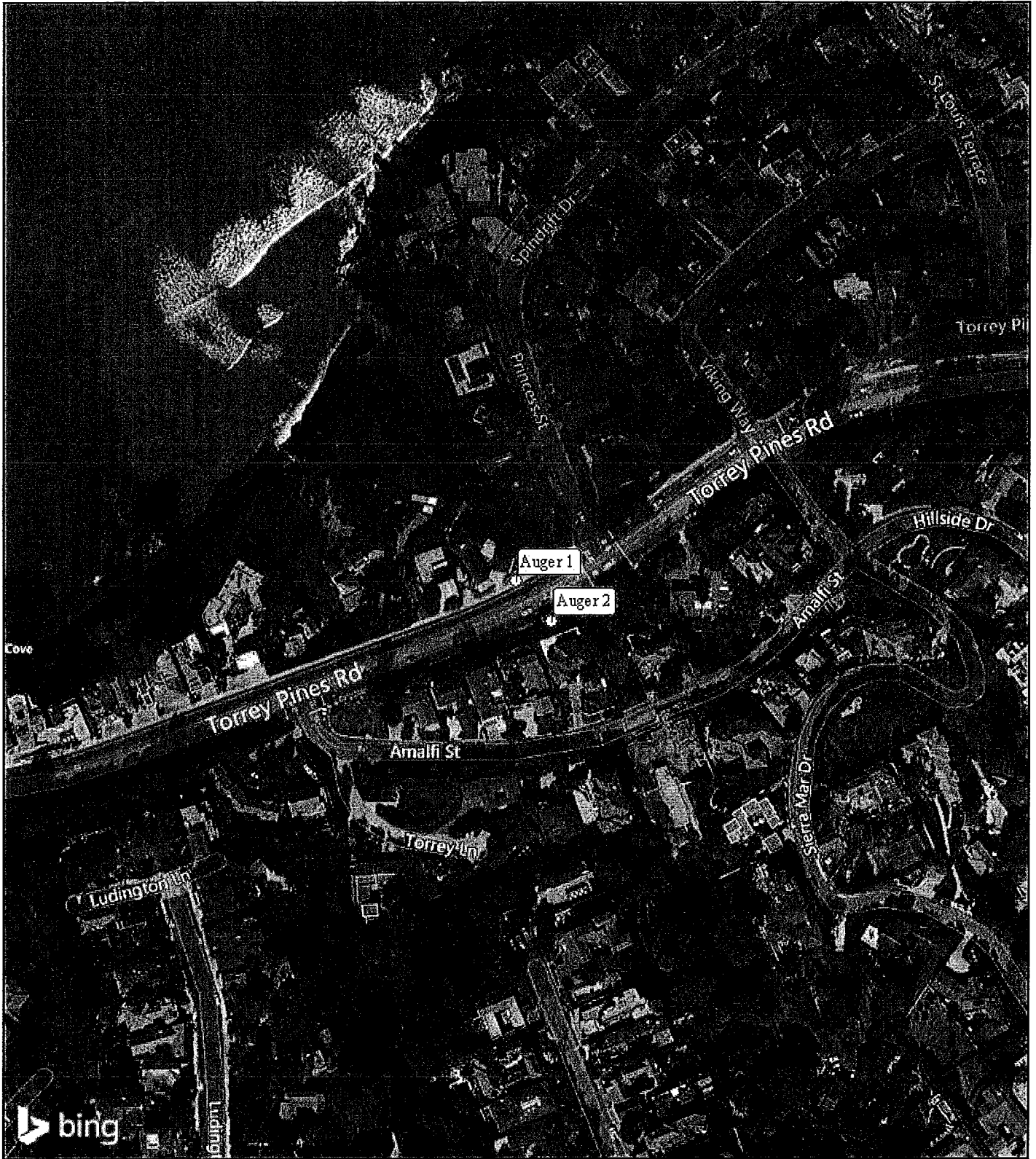

LSA

LEGEND

FIGURE 2

- Proposed Beacon Pole Location (Auger Test Location)
- Site CA-SDI-39

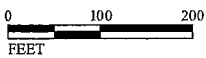

SOURCE: Aerial - Microsoft Corporation 2010

Torrey Pines Road Improvements, Phase II Project
 Proposed Beacon Pole Locations and Site CA-SDI-39

**CULTURAL RESOURCES CONSTRAINTS
ANALYSIS**

TORREY PINES ROAD IMPROVEMENTS PHASE 1

CITY OF SAN DIEGO

SAN DIEGO COUNTY, CALIFORNIA

PROJECT NO. 316432

LSA

November 2013

CULTURAL RESOURCES CONSTRAINTS ANALYSIS

TORREY PINES ROAD IMPROVEMENTS PHASE 1

CITY OF SAN DIEGO

SAN DIEGO COUNTY, CALIFORNIA

PROJECT NO. 316432

Prepared for:

Carrie Purcell, Senior Planner
Environmental and Permit Support Section
Engineering and Capital Projects Department
City of San Diego
San Diego, California

Prepared by:

Jacqueline Hall, BA
Roderic McLean, MA, RPA
LSA Associates, Inc.
703 Palomar Airport Road, Suite 260
Carlsbad, California 92614-4731
(760) 931-5471

LSA Project No. CSD1103N

National Archeological Database (NADB) Information

Type of Investigation: Constraints Analysis

USGS: La Jolla, California 7.5-minute

Sites Recorded: None

Updated Sites: None

Acreage: Approximately 3.6 acres

Key Words: Prehistoric site, CA-SDI-39, La Jolla 7.5-minute USGS quadrangle

LSA

November 2013

TABLE OF CONTENTS

INTRODUCTION.....	1
PROJECT DESCRIPTION	1
PERSONNEL.....	1
SETTING	1
Natural Setting.....	1
Cultural Setting.....	3
METHODS.....	4
RESULTS.....	5
CA-SDI-39/Spindrift Site	5
Summary.....	8
RECOMMENDATIONS	9
Subsurface Exploration.....	10
Monitoring	10
Human Remains.....	10
Summary.....	17
REFERENCES.....	18

FIGURES

Figure 1: Project Location.....	2
Figure 2: Previously Recorded Cultural Resources.....	7
Figure 3-1: Recommended Archaeological Excavation Location: Princess Street.....	11
Figure 3-2: Recommended Archaeological Excavation Location: Princess Street.....	12
Figure 4-1: Recommended Archaeological Excavation Location: Little Street.....	13
Figure 4-2: Recommended Archaeological Excavation Location: Little Street.....	14
Figure 5-1: Recommended Monitoring Locations	15
Figure 5-2: Recommended Monitoring Locations	16

TABLES

Table A: Cultural Resources within a ¼-Mile Radius of the Project Area	6
Table B: Areas of Sensitivity	9

APPENDIX

- Appendix A: Résumé of Principal Investigator
- Appendix B: Confidential Appendix

INTRODUCTION

Per your request of August 21, 2013, and in accordance with Sections 1.1 and 3.1 of our agreement dated August 2, 2011, RR-306971/H115307, LSA Associates, Inc. (LSA) is submitting this constraints analysis for Task No. 15, Torrey Pines Road Improvements Phase 1 WBS# S-00613.02.02. The project is located on Torrey Pines Road, between La Jolla Shores Drive and Prospect Place within the La Jolla Community area in the City of San Diego (City).

This constraints analysis presents the results of archaeological research completed for the Torrey Pines Road Improvements Phase 1. The purpose of this study was to gather information about the archaeological sites that may be affected by the proposed project. To accomplish this, a records search for cultural resources within a quarter-mile of the project area was examined in addition to previous surveys of the project area. A visual inspection of the most sensitive locations in the project area was completed on September 17, 2013.

PROJECT DESCRIPTION

The project is located on Torrey Pines Road, between La Jolla Shores Drive and Prospect Place, in the City of San Diego (Figure 1). The proposed project includes new and replacement sidewalks, curb ramps, cross gutters, Americans with Disabilities Act (ADA)-compliant driveways, and relocation of traffic and street lights. The relocation of streetlights will include ground disturbance to a depth of 5 feet and is proposed at four locations: Coast Walk, Princess Street, Little Street, and Roseland Drive. The installation of a new fire hydrant located at Little Street will require ground disturbance to a depth of 3 to 4 feet. Other project elements may require additional ground-disturbing or earthmoving activities, including the relocation of a water meter at St. Louis Terrace. All work will be conducted within the City of San Diego right-of-way (ROW) with some minor encroachments onto private property.

PERSONNEL

The staff at LSA meets the Federal, State, and local requirement qualifications. This study was completed by Jacqueline Hall. Ms. Hall has a B.A. in Anthropology from San Diego State University and is a certified archaeologist with the City of San Diego.

Mr. Roderic McLean served as the Project Manager and Principal Investigator. He is a member of the Register of Professional Archaeologists (RPA) and meets the Secretary of Interior's standards for a qualified archaeologist. Mr. McLean has an M.A. in Anthropology from California State University Fullerton and has extensive experience in local archaeology.

SETTING

Natural Setting

The project is located in the western portion of San Diego County on the coast of La Jolla Shores, San Diego, California. The project site is situated on an uplifted wave-cut sea terrace in a highly developed residential area, overlooking the La Jolla submarine canyon to the west. During the

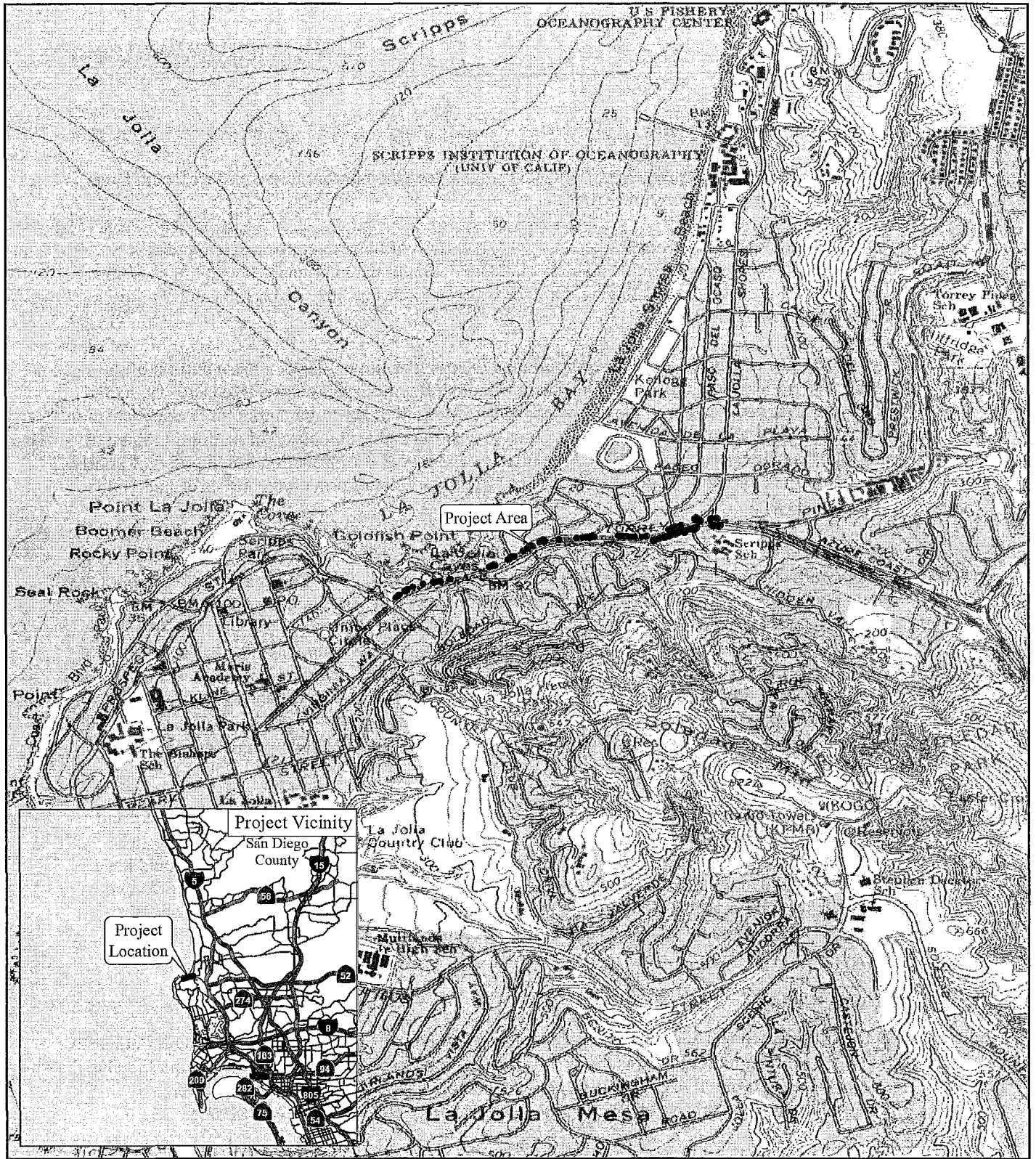

LSA

LEGEND

— Project Area

FIGURE 1

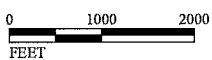

SOURCE: USGS 7.5' Quad. (La Jolla, 1975)

F:\CSD1103\NGIS\ProjectLocation.mxd (11/13/2013)

Torrey Pines Road Improvements Phase 2 and Torrey Pines Road slope Restoration
Appendix M- Archeological Report

Torrey Pines Road Improvements Project: Phase 1

Project Location

prehistoric and historic periods, San Clemente Canyon, located adjacent to the project would have served as the primary water source.

The geomorphology of the area has been formed as a result of three major geologic processes: Tectonic uplift, fluvial sediment deposition, and denudation of the landscape. The uplifted sea terrace is displaced by recent movement along the Rose Canyon Fault forming the La Jolla and Scripps Canyon submarine canyons.

The project area is situated along three different geologic formations. The southern portion of the project area is located on the Cabrillo Formation and the Bay Point Formation (Kennedy 1975) and the middle and north section of the project is located within the Bay Point and Point Loma Formation. The Cabrillo Formation overlies the Point Loma Formation and is composed of medium-grained sandstone and a cross-bedded cobble conglomerate. The Bay Point Formation is composed of poorly consolidated pale brown fossiliferous sandstone. The Point Loma Formation consists of interbedded sandstone and shale.

Based on U.S. Department of Agriculture (USDA) soil maps, there are two soil types that overlay the geologic formations within the project area: the Corralitos Loamy Sand Series and the Altamont Clay Series soil types (USDA 1973). The Corralitos Loamy Sand soil series consist of somewhat excessively drained very deep loamy sands that formed in alluvium derived from marine sediments. These soils occur in narrow valleys and on small alluvial fans. The Altamont Clay Series consists of well-drained clays that formed in material weathered from calcareous shale. Both geotechnical studies completed for the project indicate there may be fill soils present beneath the road to an unknown depth, particularly in the eastern part of the project (Ninyo and Moore 2010; City of San Diego 2003). Given the lack of specificity of these studies, the potential for intact Holocene age deposits exists beneath Torrey Pines Road.

The climate of the region can generally be described as Mediterranean, with cool, wet winters and hot, dry summers. Lack of rainfall limits vegetation growth and habitat types adapted to the dry conditions of the region occur in the project area. Prior to disturbance, the project area would have been dominated by coastal sage scrub. Animal resources in the region include deer, fox, raccoon, bobcat, coyote, rabbit, and various rodent, reptile, shellfish, fish, sea mammals and bird species. Small game, dominated by rabbits, is relatively abundant.

Cultural Setting

San Diego County archaeological investigations indicate humans have inhabited the area for at least 10,000 years. Malcolm Rogers was the first to develop a cultural chronology of the region. In general, they can be divided into five consecutive periods: Paleoindian, Archaic, Late Prehistoric, Ethnohistoric, and Historic (Bull 1983; Ezell 1987; Moriarty 1966; Warren et al. 1993).

The earliest sites in San Diego County are identified as the Paleoindian period (9,000 to 8,000 YBP [years before present]), and include the San Dieguito, La Jolla and Pauma complex. Most of these sites are located around inland dry lakes, on old terrace deposits in the California desert, and on or near the coast on mesas or terraces. The artifacts associated with this period are heavily patinated felsite tools primarily consisting of scrapers, scraper planes, choppers, large blades, and large projectile points.

Around 8,000 years ago, changes in technology begin to appear in the archaeological record. During the Early Archaic period, there is an increase in the use of grinding and seed processing technology and a change in mortuary practices, indicating population movements or internal change (Moratto 1984). There is a marked increase in the exploitation of plant and animal resources inland and on the coast. Artifacts associated with this period include an increase of Pinto and Elko series projectile points, large bifaces, manos, metates, and core tools.

The Late Prehistoric period is characterized by a series of dramatic technological changes indicating that around 2,000 YBP, people from the Colorado River area migrated to the Southern California region. This period is characterized by the appearance of smaller projectile points, ceramics, permanent bedrock milling sites, and cremation burials. There also appears to be an increase in the establishment of permanent or semi-permanent seasonal villages indicating a shift to inland plant food collection and processing.

The Ethnohistoric period occurred shortly before Europeans colonized Southern California. Documentation by the Spanish and the material culture left by the native people indicate that at the time of contact there were four distinct native groups in the area: Luiseño, Diegueño, Cupeño, and the Cahuilla (Kroeber 1925). During this period, the Native American populations dramatically decreased and were quickly assimilated into the mission system. The project area is located within the Kumeyaay territory.

The Historic period in San Diego County is generally divided into three politically defined periods: Spanish, Mexican, and American periods. The Spanish colonists first settled the Southern California region in A.D. 1769 and established military and religious institutions along the coast. In 1821, Mexico won its independence from Spain and California came under Mexican rule. By 1834, the Spanish missions had been secularized and large tracts of land, or ranchos were granted to Mexican citizens. Mexican rule ended with the signing of the Treaty of Guadalupe Hildalgo in 1848 when Alta California was ceded to the United States.

The La Jolla area became the focus of development in San Diego in the late 1800s when a railroad connection to the San Diego Area resulted in a population boom in Southern California. The La Jolla area was purchased by Frank Terrill Botsford, who eventually subdivided the land into lots. The La Jolla Park Hotel opened in 1893 and small cottage style houses were built in the area. From 1900 to 1920, the area served mainly as a tourist attraction and artist's colony. Most of modern La Jolla was developed during the 1920s and the 1940s following the end of both World Wars. By the 1960s, La Jolla had been completely developed and today it continues to be a popular tourist destination, and commercial and residential area.

METHODS

This constraints analysis includes both a review of archival research and a visual inspection of the most sensitive locations in the project area. The Cultural Resources Constraints Analysis for the Torrey Pines Road Median Improvement Project (Davidson and McLean 2010) was also revisited. Archival research was completed at the South Coastal Information Center (SCIC) and the City of San Diego's Development Services Department (DSD) in October 2010. The archival research conducted at SCIC included a site records search, literature review, and an examination of historic maps within a

quarter-mile of the project area. Research conducted at the DSD included an examination of the City's archaeological sensitivity maps and a review of select project reports completed within the project area as well as verbal communication with City archaeologist Myra Herrmann. Additional documents provided by the City's Engineering and Capital Projects Department including the project engineering plans and two geotechnical reports (Ninyo and Moore 2010; City of San Diego 2001) were also examined. A visual inspection of the most sensitive locations in the project area was also completed on September 17, 2013, by Roderic McLean and Jacqueline Hall. The visual inspection included a pedestrian survey of the project area along Torrey Pines Road between Princess Street and Roseland Drive, with special attention paid to the depth of the Torrey Pines road cut and whether surface artifacts were located within the project area. Areas with exposed soil within the project area were inspected for the presence of surface artifacts.

RESULTS

The records search indicated that at least 125 studies have been conducted within a ¼ mile of the project area. They include a wide range of survey, excavation, monitoring, geotechnical, and historic property assessments. Forty-four (44) of the studies are historic resource assessment reports for historic properties in the area. Thirty (30) of the reports are research work plans, archaeological overview assessments, and constraints studies. Thirty-one (31) of the studies are survey, testing, or data recovery reports and thirteen (13) are monitoring reports. The remaining seven reports are geotechnical or negative declaration reports. Additional documents not included with the SCIC records search were provided by the City's Engineering and Capital Projects Department and included engineering plans for new and replacement sidewalks, curb ramps, cross gutters, ADA-compliant driveways, and relocation of traffic and street lights.

The records search completed at the SCIC identified a total of 17 cultural resources: 11 sites and 6 isolates within the ¼ mile search radius (Table A and Figure 2). One of these resources, Site CA-SDI-39 is recorded within the central portion of the project area. The records search conducted at DSD in consultation with Ms. Herrmann also indicates Site CA-SDI-39 is partially located within the project area. Additional reports including the Archaeological Monitoring of Excavation during construction of the La Jolla Shores Pipeline Phase II Project, conducted along Torrey Pines Road indicated that Site CA-SDI-39 does not appear to extend into the Torrey Pines Road cut. This resource is discussed in greater detail below.

CA-SDI-39/Spindrift Site

The project area is located within the southern boundaries of the prehistoric/ethnohistoric habitation area of Site CA-SDI-39 (see Confidential Appendix, Figure 2). Prior to development, this area encompassed a large habitation area known as *Mut kula xuy/Mut lah hoy ya* meaning "the place of many caves" (Christenson 1998). It is also known as the Spindrift Site (Rogers 1926).

The site was originally noted by Welty in 1913. Subsequent observations and data recovery of portions of the site were completed by various scholars including Malcolm Rogers. In the 1920s–1930s, Rogers excavated portions of the site and officially recorded the Spindrift Site as SDM-W-1 at the Museum of Man. Subsequent studies were also completed by Moriarty (1966), Roth and Berryman (1993), Wade (1998), Gross and Robbins-Wade (1999), Schultz and Gross (1999),

Table A: Cultural Resources within a ¼-Mile Radius of the Project Area

Site Number	Site Type	Recorder
P-37-017063	Historic Building	Pierson (1999)
P-37-017086	Historic Building	Moonjian and Brandes
P-37-023770	Coast Walk Trail	City of San Diego (nd)
P-37-025496	Historic Building	May Vonn (2003)
P-37-027459	Historic Isolate	Affinis (2005)
P-37-027460	Historic Isolate	Affinis (2005)
CA-SDI-39	Prehistoric Habitation Site	Nelson (nd)
CA-SDI-12989	Prehistoric Shell and Lithic Scatter (secondary deposit)	Whitehouse (1992)
CA-SDI-12990	Prehistoric/Historic Trash Scatter (secondary deposit)	Whitehouse (1992)
CA-SDI-12291	Prehistoric/Historic Trash Scatter	Schultz (1992)
CA-SDI-14282	Prehistoric Lithic and Shell scatter	BFSA (1996)
CA-SDI-17372/SDI-39	Prehistoric Village	Affinis (nd)
CA-SDI-17550	Historic Trash Scatter	Case (2004)
CA-SDI-18305	Prehistoric Shell Scatter (secondary deposit)	Cheever (1994)
CA-SDI-18996	Prehistoric Shell Scatter	Underwood (2007)
CA-SDI-19056	Prehistoric/Historic Trash Scatter (secondary deposit)	BFSA (2008)
CA-SDI-19310	Historic Trash Deposit (secondary deposit)	Davidson (2008)

Figure 2: Previously Recorded Cultural Resources
(See Appendix B: Confidential Appendix)

Pigniolo and Baksh (1999), Smith (2000), Case (2003), Gilletti and Alter (2006), Davidson (2007), and Pigniolo et al. (2010). Rogers noted that cultural material included ceramics, groundstone, stone bowls, charcoal, cobble hearths, shell midden, and burials.

In 2005, a monitoring and excavation program for an underground utility project was completed by Laguna Mountain Environmental along Spindrift Drive between Princess Street and Paseo Dorada. The program resulted in the recovery of hundreds of artifacts including groundstone tools, chipped lithic tools, flakes, debitage, bone tools, pottery, shell tools, shell decorations, shell, terrestrial and marine mammal remains, charcoal, and fire-affected rock (Pigniolo et al. 2010). Several burials, including cremations and flexed burials were also recovered from the site.

In 2007, Davidson completed a study in which all of the disparate archaeological data were combined into a Geographic Information System (GIS) database in order to better define the horizontal and vertical site boundaries and identify areas where intact deposits appear to still be present. Based on the data, most of the intact deposits appear to be within the west-central portion of the site along Spindrift Drive between St. Louis Terrace and Paseo Dorado and areas along St. Louis Terrace as well as Roseland Drive.

A monitoring program completed by Affinis at 7948 Roseland Drive resulted in the recovery of four flexed burials and hundreds of artifacts (Robbins-Wade 2010). Based on the collective data recovery and monitoring programs, it appears that some portions of the site have been disturbed but portions of the site are still intact. The Spindrift Site is important because it has and continues to produce some of the most significant archaeological data for coastal prehistoric cultures in both the San Diego and Southern California region.

In 1995, monitoring for the La Jolla Shores Pipeline Project recorded that most of the soils along Torrey Pines Road is fill (Brown 1996). A limited amount of cultural material was encountered including historic and prehistoric artifacts; however, these deposits were observed as secondary deposits within old utility trench fill soil. The disturbed cultural material was located on Torrey Pines Road between Prospect Place and Coast Walk (St#16+00 to ST# 22+00).

Summary

As the City of San Diego is aware, and based on the records search, one cultural resource, CA-SDI-39/Spindrift Site is within the project area (see Confidential Appendix: Figure 2). The Spindrift Site is considered important because it represents a large habitation site that has yielded hundreds of artifacts and human remains. The central portion of the project area is located within the southern boundary of the Spindrift Site and, if prehistoric cultural resources are encountered, they will most likely be associated with this site.

Additional sites are recorded within a quarter-mile of the project area. CA-SDI-12990, CA-SDI-18996, and CA-SDI-19056 represent disturbed historic and prehistoric secondary deposits associated with the Spindrift Site and early development of the La Jolla area. Secondary deposits are often encountered in the older San Diego neighborhoods. These sites retain little integrity, appear discrete, and do not extend into the project area. However, these secondary deposit sites are representative of the kinds of resources that may be encountered within the project area and may contain human

remains. Any human remains encountered in these secondary deposits are as important as an intact burial and should be treated as such.

Areas of Sensitivity. The entire area, although located in a heavily developed urban area and no cultural resources are observed on the surface of the proposed streetlight and fire hydrant locations, is sensitive for cultural resources; however, there are areas within the project area that are considered even more sensitive than others because of the possibility to encounter buried intact cultural deposits including human remains. Although Torrey Pines Road has been graded, there is a potential to encounter Holocene age deposits because construction of Torrey Pines Road may not have removed all deposits dating to the last 10,000 years. Archaeologically, areas considered highly sensitive for resources include the areas where the project area overlaps the southern boundary of the previously recorded Spindrift Site (see Confidential Appendix: Figure 2). Areas identified as moderately sensitive are less likely to contain human remains and other cultural material but still have the potential to contain secondary deposits. These include the areas east and west of the Spindrift Site boundaries. Table B shows both the high and moderate sensitivity areas in relation to the engineering station numbers (STA) as well as street names.

Table B: Areas of Sensitivity

Level of Sensitivity	Station Number (STA)	Street Names
High	STA 31+50 to STA 44+00	Princess Street to Little Street
Moderate	STA 16+00 to STA 31+50 and STA 44+00 to 60+00	Prospect Place to Princess Street and Little Street to La Jolla Shores Drive

RECOMMENDATIONS

As the City of San Diego is aware, the Spindrift Site is one of the most important archaeological sites in San Diego because it continues to produce some of the most significant archaeological data for coastal prehistoric cultures in both the San Diego and Southern California region. The project area is partially located within the site boundaries (even though the currently recorded resource boundary is in places subjective); therefore, the entire project area required assessment regarding sensitivity for cultural resources, particularly human remains, hence the need for this constraints analysis discussed herein. To summarize the results of the constraints analysis, the area has been highly disturbed by grading and filling activities associated with Torrey Pines Road, bluff stabilization, and residential structures. Even with the possibility of disturbance to depth, it cannot be said with scientific certainty that intact Holocene age deposits are absent below the surface at Princess Street (St# 31+90) and Little Street (St# 43+25).

Although there may be low potential for intact deposits, the presence of burials even in a disturbed deposit is a particularly sensitive issue for Native Americans. Whereas in all cases, Native Americans prefer burials be avoided and not disturbed, taking into consideration archaeological issues, LSA recommends the implementation of both an archaeological hand excavation (subsurface exploration) and monitoring program, as discussed in greater detail below.

Subsurface Exploration

The project area is partially located within the southern boundary of Site CA-SDI-39. One of four streetlights requires relocation in this area. The streetlight relocation at Princess Street (St# 31+90) would require excavation to a depth of five feet. Additionally, one new fire hydrant located at Little Street (St# 43+25) will be installed, requiring excavation to a depth between 3 and 4 feet. Although the area has been heavily developed, there is still potential to uncover buried deposits, especially within or adjacent to the boundary of the Spindrift Site. Due to its proximity to this site, hand excavation of the streetlight relocation at Princess Street (Figure 3-1 and Figure 3-2) and the new fire hydrant at Little Street is recommended (Figure 4-1 and Figure 4-2). LSA recommends that the ground disturbance for the streetlight relocation at Princess Street and the new fire hydrant at Little Street be excavated by an archaeologist. All sediments will be dry screened. If cultural deposits are encountered, those deposits will be water screened.

Monitoring

The area is highly sensitive for cultural resources due to its proximity to the Spindrift Site. The Spindrift Site has yielded hundreds of artifacts and over 50 burials including cremations and inhumations. Burials are considered the most important element of cultural heritage by Native American people. The horizontal and vertical limits of this site have not been fully documented, and secondary deposits have been observed outside of the main site area, suggesting the potential for cultural material to occur within the project area. As stated before, the project involves ground-disturbing activities including the relocation of four streetlights, three of which are outside the Spindrift site boundary. These locations include west of Coast Walk (St# 22+00), east of Little Street (St# 47+20), and east of Roseland Drive (St# 50+00) (Figure 5). Though they are outside the site boundary for CA-SDI-39, there is potential for cultural material to occur at these locations. Archaeological and Native American monitoring during ground-disturbing activities at these locations is recommended. The relocation of a water meter at St. Louis Terrace (St# 36+90) is within the site boundary for CA-SDI-39 (Figure 5-1 and Figure 5-2). The maximum ground disturbance will be to a depth of 1 foot. Because the water meter will be relocated to an area previously disturbed by utilities, the potential to encounter intact deposits at this depth is low. The area is still considered sensitive, and monitoring during excavation of this location is recommended. Additionally, monitoring is recommended for any other areas where ground-disturbing and earthmoving activities occur.

Human Remains

The proximity of the project area within the Spindrift Site means there is a potential for prehistoric human remains to be discovered. If any human remains, including elements of a burial, grave goods, or objects of cultural patrimony, are found, the archaeologist will immediately communicate the find to the LSA Project Manager, who will contact the County Coroner and the City of San Diego Project Manager. California Health and Safety Code Section 7050.5 states that no further disturbance shall occur until the County Coroner has made a determination of origin and disposition pursuant to Public Resources Code Section 5097.98; therefore, the County Coroner must be notified of the find immediately. If the remains are determined to be Native American, the County Coroner will notify the Native American Heritage Commission (NAHC), which will determine and notify a Most Likely

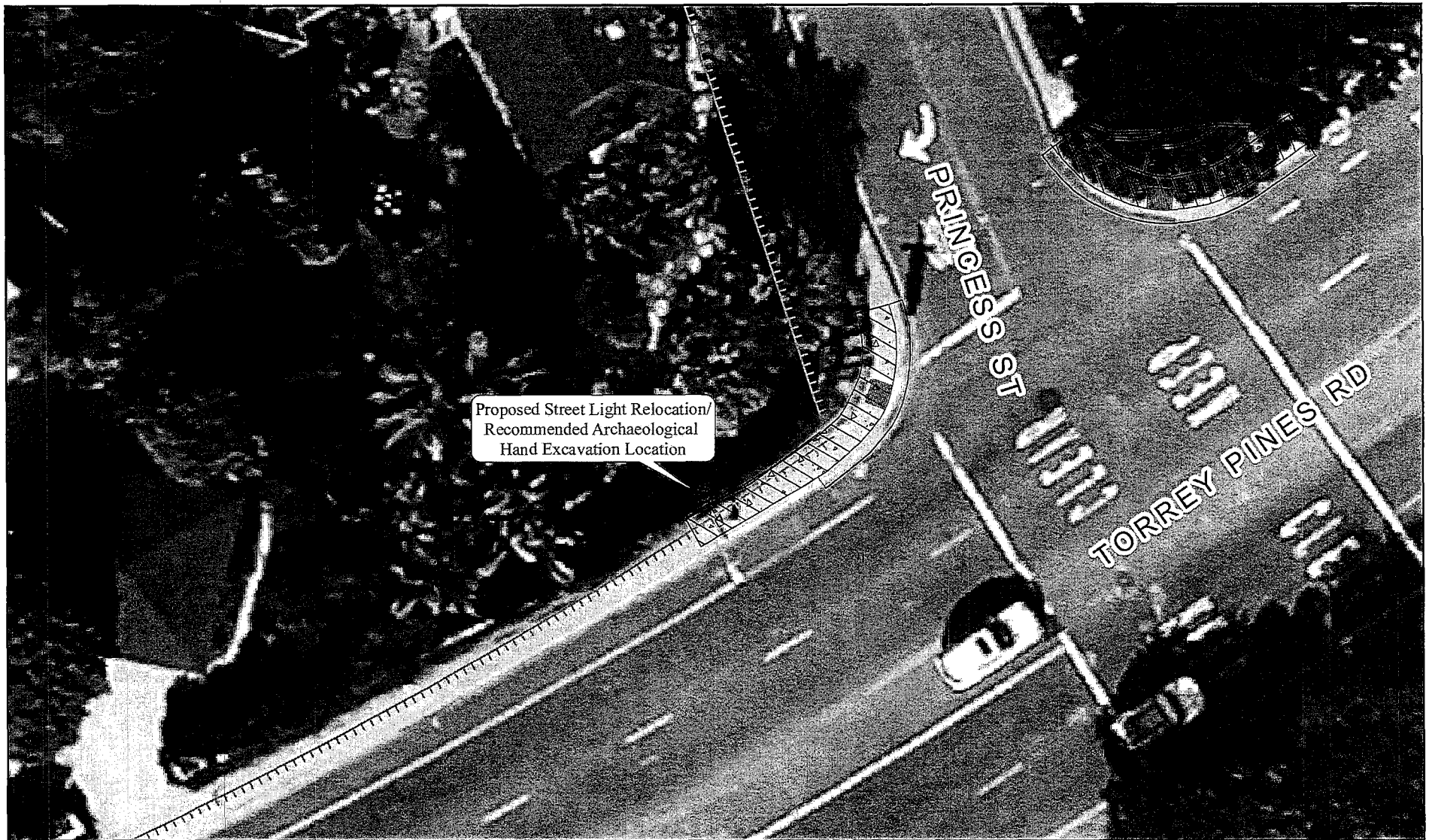
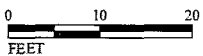

FIGURE 3-1

LSA



LEGEND

- Proposed Streetlight Relocation/Recommended Archaeological Hand Excavation Location
- CAD Engineering Plans for Improvements (Project Area)
- |||| Existing ROW

SOURCE: SCIC (2010); Aerial-Google Earth (11/2011)

Figure 3-2: Recommended Archaeological Excavation Location: Princess Street
(See Appendix B: Confidential Appendix)

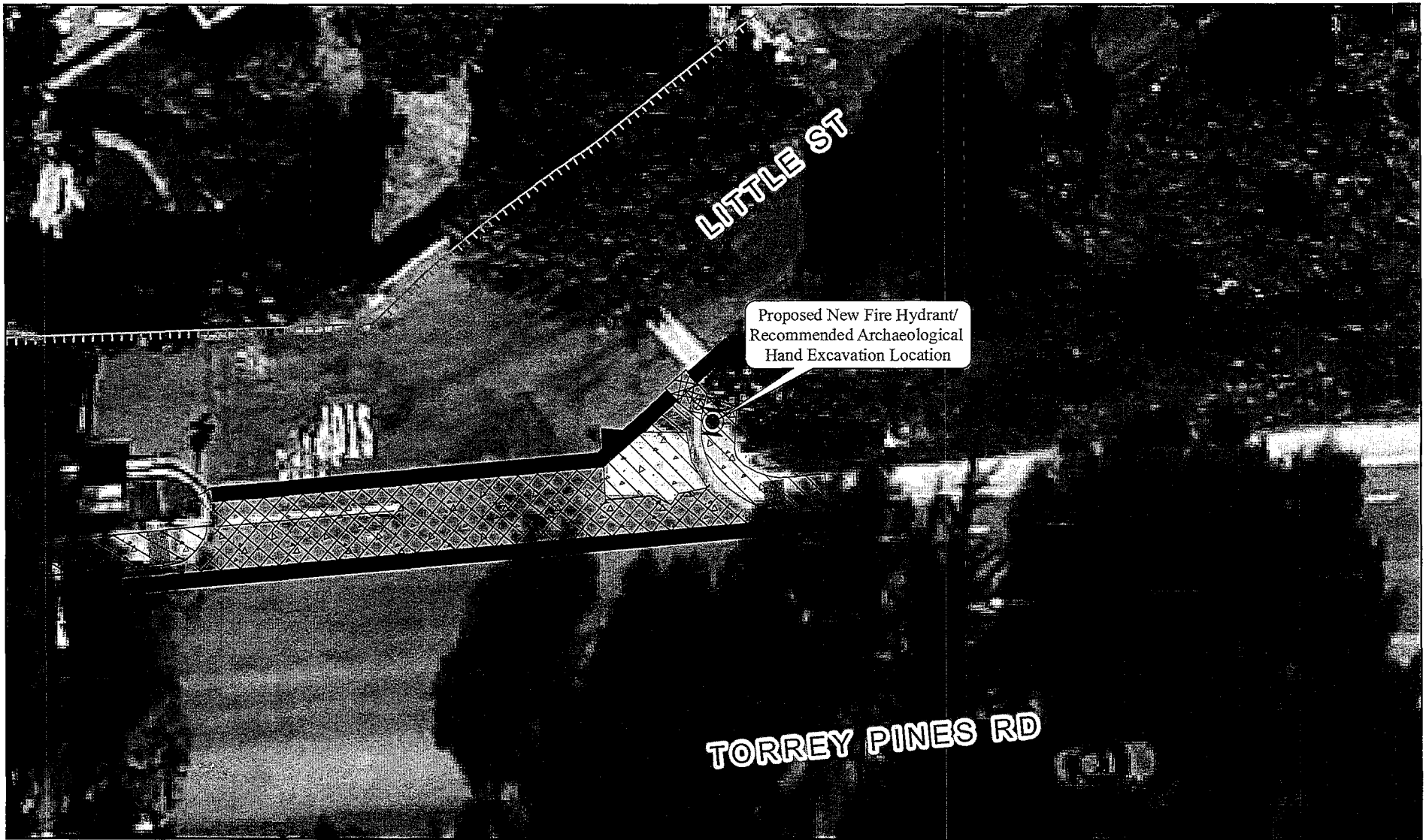
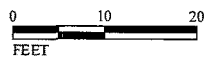

FIGURE 4-1

LSA



LEGEND

- Proposed Streetlight Relocation/Recommended Archaeological Hand Excavation Location
- CAD Engineering Plans for Improvements (Project Area)
- Existing ROW

SOURCE: SCIC (2010); Aerial-Google Earth (11/2011)

Figure 4-2: Recommended Archaeological Excavation Location: Little Street
(See Appendix B: Confidential Appendix)

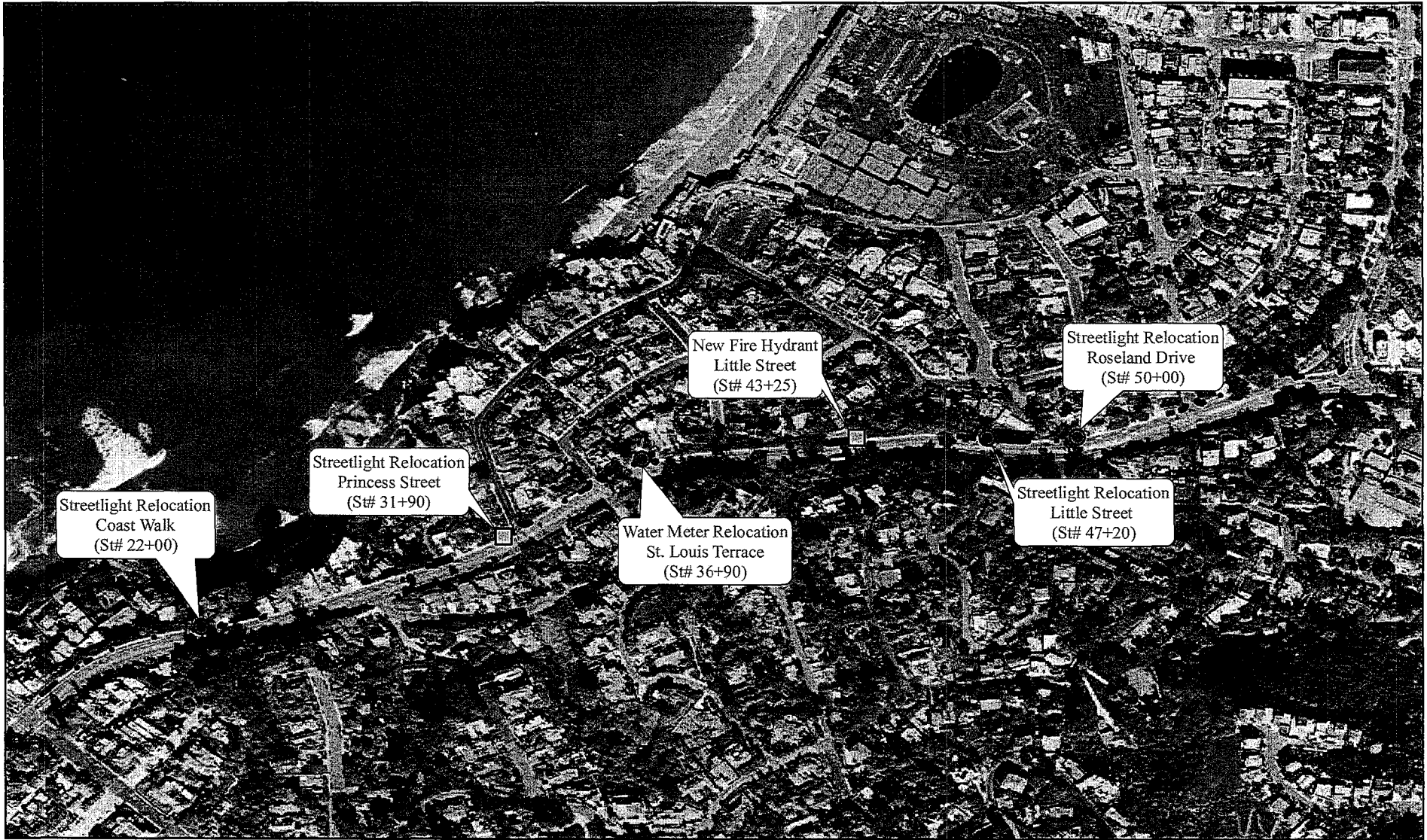



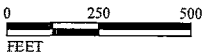

FIGURE 5-1

LSA

LEGEND

-  Project Area
-  Monitoring Recommended
-  Archaeological Hand Excavation Recommended



SOURCE: SCIC (2010)

Figure 5-2: Recommended Monitoring Locations
(See Appendix B: Confidential Appendix)

Descendant (MLD). The MLD may inspect the site of the discovery, and shall complete the inspection within 24 hours of notification by the NAHC. The MLD may recommend scientific removal and nondestructive analysis of human remains and items associated with Native American burials.

Summary

Based on the research conducted for this project, the entire project area, although located in a heavily developed urban area, is sensitive for cultural resources. However, there are areas within the project area that are considered even more sensitive than others because of the possibility to encounter buried intact cultural deposits, including human remains. The most sensitive areas (i.e. potential for buried resources) are located within the project area where it overlaps with the southern boundary of the Spindrift Site. Project impacts to this area include the relocation of a streetlight at Princess Street (St# 31+90) and a new fire hydrant at Little Street (St# 43+25). For this high-sensitivity area and the depth of ground disturbance proposed (up to five feet), LSA recommends that archaeologists hand excavate the locations of the new Princess Street streetlight and the new Little Street fire hydrant prior to the start of any construction related activities. LSA also recommends the presence of a full-time archaeologist and Native American Monitor during any and all earthmoving and ground-disturbing activities associated with the project, including three additional streetlight locations at Coast Walk (St #22+00), Little Street (St #47+20), and Roseland Drive (St #50+00).

REFERENCES

Brown, Joan C.

- 1996 Archaeological Monitoring of Excavation during Construction of the La Jolla Shores Pipeline Phase II, La Jolla, California. Unpublished technical report on file at the South Coastal Information Center, San Diego State University.

Bull, Charles

- 1983 Shaking the Foundations: The Evidence for San Diego Prehistory. *Casual Papers*, 2(3):15-64. Cultural Resource Management Center, Department of Anthropology, San Diego State University.

Case, Robert P.

- 2003 Limited Phase II Investigation of CA-SDI-39 Within the Hazard Property, 1876 Torrey Pines Road (APN 346-454-0900), La Jolla, California. Unpublished technical report on file at the South Coastal Information Center, San Diego State University.

Christenson, Lynn

- 1998 Archaeological History of CA-SDI-39 (Museum of Man #W-1) The Kumeyaay Village of MUT-LLEHUP (Spindrift Site). On file at the SCIC.

City of San Diego

- 2003 Geotechnical Basis of Design: Storm Drain Replacement. 5998 Camino De la Cosa, San Diego, California. Unpublished Report from the City of San Diego.
2001 San Diego Municipal Code, Land Development Code: Historical Resources Guidelines. San Diego, California.

Davidson, Elizabeth E.

- 2007 Establishing Boundaries: A GIS Analysis of the Village of *Mut kula xuy/Mut lah ho j Archaeological Site In La Jolla California*. Unpublished Thesis Dissertation, University of Leicester, United Kingdom.

Davidson, Elizabeth E., and Roderic McLean

- 2010 Cultural Resources Constraints Analysis: Torrey Pines Road Median Improvement Project. Prepared for the City of San Diego, California.

Ezell, Paul

- 1987 The Harris Site – An Atypical San Dieguito Site or am I Beating a Dead Horse? In *San Dieguito – La Jolla: Chronology and Controversy*, edited by Dennis Gallegos, pp. 15–22. San Diego County Archaeological Society Research Paper No. 1. San Diego.

Gilletti, Andrew, and Ruth Alter

- 2006 Archaeological Resource Testing of the Residence at 1908 Hypatia Way, La Jolla, California. Unpublished technical report on file at the South Coastal Information Center, San Diego State University.

- Gross, G. Timothy, and Mary Robbins-Wade
1999 Archaeological Resources Testing of the Residence at 1900 Spindrift Drive, La Jolla, San Diego, California. Unpublished technical report on file at the South Coastal Information Center, San Diego State University.
- Kennedy, Michael P.
1975 Geology of the San Diego Metropolitan Area. California. USDA Soil Conservation Service and Forest Service.
- Kroeber
1925 Handbook of the Indians of California. California Book Company, Berkeley. Originally published as Bureau of American Ethnology Bulletin 78.
- Moriarty, James R., III
1966 Culture Phase Divisions Suggested by Typological Change Coordinated with Stratigraphically Controlled Radiocarbon Dating at San Diego. Canadian Journal of Anthropology 4(4):20-30.
- Moratto, Michael J.
1984 California Archaeology. New York: Academic Press.
- Ninyo and Moore
2010 Geotechnical Reconnaissance: Torrey Pines Road Realignment, San Diego, California. Unpublished report on file at Geotechnical and Environmental Sciences Consultants.
- Pigniolo, Andrew R., and Associates
2010 Data Recover Report for the Princess Street/Spindrift Drive Underground Utility Project. Unpublished in process report available at Laguna Mountain Environmental. San Diego, California.
- Pigniolo, Andrew R., and Michael Baksh
1999 Cultural Resources Inventory of the Coastal Low Flow Storm Drain Diversion System, City of San Diego, California, LDR#99-0232. Unpublished technical report on file at the South Coastal Information Center, San Diego State University.
- Robbins-Wade, Mary
2010 Archaeological Monitoring at a Residence on Roseland Drive, Spindrift Site (CA-SDI-39), La Jolla, California. Memo Regarding Results. Unpublished Report, Affinis and Affiliates, El Cajon.
- Rogers, Malcolm J.
1926 A preliminary Survey of the La Jolla Finds. Manuscript on file at the San Diego Museum of Man.
- Rogers, Malcom
n.d. Site record notes for SDM-W-1 and SDM-W-2. On file at South Coastal Information Center, San Diego State University, San Diego, California.

Roth, L., and J.A. Berryman

- 1993 Survey, Significance Testing, and Proposed Mitigation on a Portion of SDM-W-1 (SDI-39) and Historic Evaluation of Parcel #346-461-6, City of San Diego, CA DEP No. 92-0719. Unpublished technical report on file at the South Coastal Information Center, San Diego State University.

Schultz, Richard and Tim Gross

- 1999 Wassenaar Residence Archaeological Monitoring: LDR No. 96-7773. Affinis. Submitted to Myra Herrmann. Unpublished Report on file at South Coastal Information Center, San Diego State University.

Smith

- 2000 Enhanced Cultural Resource Survey for the Malk Residence Project, La Jolla, City of San Diego. Unpublished technical report on file at the South Coastal Information Center, San Diego State University.

United States Department of Agriculture (USDA)

- 1973 Soil Survey, San Diego Area, California. Beltsville, Maryland.

Wade, Sue A.

- 1998 Cultural Resource Survey and Test Excavations for a Portion of CA-SDI-39/SDM-W-1. Unpublished technical report on file at the South Coastal Information Center, San Diego State University.

Warren, Claude N., Gretchen Sieglar, and Frank Dittmer

- 1993 Paleoindian and Early Archaic Periods. In Historic Properties Background Study for the City of San Diego Clean Water Program. Brian F. Moody and Associates.

Welty, Howard O.

- 1913 Letter Report to A. L. Kroeber. Ms. On file at the University of California, Berkeley, Department of Anthropology, Archaeological Research Facility.

APPENDIX A

RÉSUMÉ OF PRINCIPAL INVESTIGATOR



EXPERTISE

Cultural Resources Project Management
Archaeology
Cartography
Forensic Archaeology

EDUCATION

California State University, Fullerton, M.A., Anthropology/Archaeology, 2003. Thesis title: *The Material Culture of Fort Whipple*.
University of California at Los Angeles, B.A., Anthropology/Archaeology, 1978.
West Los Angeles Community College, A.A., Anthropology, 1976.

PROFESSIONAL AFFILIATIONS AND APPROVALS

Society for American Archaeology
Pacific Coast Archaeological Society
San Diego County Archaeological Society

PROFESSIONAL RESPONSIBILITIES

Mr. McLean has over 30 years of experience as a professional archaeologist, including almost 13 years as a staff archaeologist with the U.S. Army Corps of Engineers, and extensive experience throughout California, in Nevada and Arizona. Mr. McLean exceeds the Secretary of Interior's *Qualification Standards for Archaeology and Historical Preservation*. Mr. McLean is also certified by the County of San Diego as qualified to direct archaeological studies for California Environmental Quality Act (CEQA) projects and has worked extensively in San Diego County. His area of expertise lies in both prehistoric and historic archaeology, and compliance with Section 106 of the National Historic Preservation Act (NHPA). Mr. McLean is responsible for directing studies and writing cultural resource assessment reports to meet the compliance requirements of the NHPA and CEQA; consulting with the Office of Historic Preservation; conducting Native American consultation; assessing resource significance and project effects; mitigation planning and execution; directing archaeological surveys and excavations; and preparing Historic American Building Survey/Historic American Engineering Record documentation. Additionally, he performs peer and third-party review of draft cultural resources documents, including in support of federal agency compliance with 36 CFR Part 800. Mr. McLean provides mapping and survey instruction to graduate students participating in the annual California State University, Los Angeles field school on San Nicolas Island. He is also an advisory board member for the Master of Arts Degree Program in Applied Archaeology at California State University, San Bernardino.

PROJECT EXPERIENCE

**Coastal Rail Trail Project
San Diego County, California**

Under contract with the City of Carlsbad, Mr. McLean is directing the cultural resources studies in support of Section 106 and NEPA compliance regarding a planned recreational trail.

**Del Mar Fairgrounds
Del Mar, California**

Mr. McLean is Principal Investigator for several ongoing studies within and adjacent to the Fairgrounds.

**Southern California Edison (SCE), Archaeological on-call, Purchase Order No. 4500031959
Various Locations, California**

As Project Manager and Lead Principal Investigator, Mr. McLean is responding to all requests for services and provides the Consultant Work Assignments and cost estimate spreadsheets for approval regarding each

**PROFESSIONAL
EXPERIENCE**

Associate, LSA Associates, Inc.,
California, 2004–present.

Staff Archaeologist (GS-11),
U.S. Army Corps of Engineers,
Los Angeles District (southern
half of California and entire
state of Arizona), 1991–2004.

Forest Service Program
oversight, U.S. Forest Service,
1998 and 2000.

Team Anthropologist, U.S.
Army Central Identification
Laboratory, Hawaii, 1997.

Senior Archaeologist (GS-12),
U.S. Army Corps of Engineers,
Los Angeles District,
September 1–October 31, 1996.

Co-Principal Investigator,
INFOTEC Research, 1991.

Field Director, Chambers
Group, Inc., Santa Ana,
California, 1989–1991.

Field Director, Keith
Companies, Costa Mesa,
California, 1989.

Field Director, Scientific
Resource Surveys, Huntington
Beach, California, 1988–1989.

Field Director, Tetra-Tech, Inc.,
San Bernardino, California,
1988.

Archaeologist/Cartographer,
Chambers Group Inc., Santa
Ana, California 1987–1988.

Archaeologist, Archaeological
Associates, Sun City,
California, 1985–1988.

Crew Chief, Harmsworth
Associates, Laguna Hills,
California, 1987.

Archaeologist, Westec Services,
San Diego, California, 1986.

Archaeologist, W & S
Consultants, Los Angeles,
California, 1985.

Archaeologist, Peak and
Associates, Sacramento,
California, 1985.

Archaeologist, Louis Berger and
Associates, San Bernardino,
California, 1985.

PROJECT EXPERIENCE (CONTINUED)

project. Additionally, he reviews the draft reports in the role of Principal Investigator prior to submittal to SCE.

**Solar One Project
San Bernardino County, California**

As part of as needed services to Stirling Energy Systems, Inc., Mr. McLean (Project Manager and PI) has assembled a team who are reviewing the draft cultural technical documents on behalf of the Bureau of Land Management (BLM). Additionally, he produced a Plan of Development matrix to facilitate the BLM's review of the Application of Certification submitted to the California Energy Commission and the BLM.

**Solar Two Project
Imperial County, California**

Mr. McLean has assembled a team who are reviewing the draft cultural technical documents on behalf of the BLM and the CEC as part of as needed services to SES. He is acting as Project Manager and Principal Investigator on this project and is also providing Section 106 expertise to the BLM and is managing a team of LSA archaeologists who are providing Native American government-to-government consultation support to the BLM.

**Sunrise Powerlink Project
San Diego and Imperial Counties, California**

Mr. McLean is Project Manager and Principal Investigator under contract with San Diego Gas & Electric Company to provide third-party review of draft cultural resources documents to the BLM. He is also providing Section 106 expertise to the BLM including preparation of a Programmatic Agreement for the project. Mr. McLean has assembled a team to support the BLM in government to government consultation with Tribes, including organizing meetings and making multiple telephone calls to interested tribes on behalf of the BLM.

**El Casco (Oak Valley) System Substation Project
Riverside and San Bernardino Counties, California**

Project Manager and Lead Principal Investigator for contract with Southern California Edison regarding identification and evaluation of cultural resources for a proposed substation and reconductor line project.

**Los Coches Creek Middle School
Alpine, San Diego County, California**

LSA performed an archaeological survey and evaluation of identified archaeological sites at the location of a proposed school. Mr. McLean reviewed and edited the final report.

**PROFESSIONAL
EXPERIENCE
(CONTINUED)**

Unit Leader/Excavator,
Scientific Resource Surveys,
Inc., Huntington Beach,
California, 1984–1985.

Excavator/Mapping,
Archaeological Associates, Sun
City, California, 1984–1985.

Archaeologist/Cartographer,
California State University,
Fullerton, 1984.

Photographer, Department of
Anthropology, California State
University, Long Beach, 1983.

Research Assistant, New
Mexico Archaeological
Services, Inc., Carlsbad, New
Mexico, 1981–1982.

Site Director, Center for
American Archeology,
Kampsville, Illinois, 1979–
1981.

Survey Leader/Archaeologist,
Illinois State Museum,
Springfield, Illinois, 1979.

Archaeologist, Social Process
Research Institute, University of
California at Santa Barbara,
1978–1979.

GS-5/Archaeologist, National
Forest Service, U.S. Department
of Agriculture, Modoc National
Forest, 1978.

Archaeologist, University of
California at Los Angeles, 1978.

**PROFESSIONAL
CERTIFICATIONS**

Register of Professional
Archaeologists (RPA)

County of San Diego Certified
Consultant

Hazardous Waste
Operations/Emergency
Response –

40 Hour Course per 29 CFR
1910.120 and GISO 5192

PROJECT EXPERIENCE (CONTINUED)

**Sports Arena Arco Station
San Diego, California**

LSA performed construction monitoring at the CA-SDI-10530/H West Point Loma Dump site. Mr. McLean reviewed and edited the final report.

**South Orange County Transportation Infrastructure Improvement
Project**

Orange and San Diego Counties, California

Principal Investigator (PI) regarding the identification and evaluation of cultural resources within the project's area of potential effects (APE).

**Fagan Ranch
Ventura County, California**

Project Manager for the identification of cultural resources within proposed housing development.

**Oak Valley, Champions Golf Course
Riverside County, California**

PI for the identification, evaluation, and treatment of cultural resources within proposed housing development.

**Truckee Meadows
Washoe County, Nevada**

Consultant to the U.S. Army Corps of Engineers in the identification, evaluation, and treatment of cultural resources within proposed flood control project.

**SCE Power Pole Upgrades
Santa Catalina Island, California**

Co-PI for contract with Southern California Edison regarding identification for cultural resources for planned power pole upgrades.

**Laguna Canyon Excavations
Orange County, California**

Project Manager for a contract with the California Department of Transportation (Caltrans) regarding the data recovery (mitigation) excavations of prehistoric village site CA-ORA-1055.

**Olinda Alpha Landfill Expansion
Orange County, California**

Mr. McLean served as the Principal Investigator for surface surveys of proposed landfill expansion.

SPECIAL TRAINING

University of Alabama,
Huntsville: Environmental
Impact Assessment of Projects

University of Nevada, Reno:
Geomorphology in
Archaeological Analysis, Native
American Grave Protection and
Repatriation Act (NAGPRA):
Implications and Practical
Application

U.S. Department of the Interior:
Remote Sensing/Geophysical
Techniques for Cultural
Resource Management

U.S. General Services
Administration: Federal Projects
and Historic Preservation Laws

Advisory Council on Historic
Preservation: Agreement
Documents Preparation

U.S. Army Corps of Engineers:
Cultural Resources

Environmental Laws and
Regulations

Global Positioning Systems

Hazardous Waste
Operations/Emergency
Response (40 Hour Course)

Historic Structures,
Maintenance and Repair

Geographic Information
Systems (GIS)

Remote Sensing Techniques

TEACHING

Invited instructor of survey and
mapping, California State
University, Los Angeles (since
1995) for annual field school on
San Nicolas Island.

Annual instruction in forensic
archaeology at El Toro High
School.

**ACADEMIC
APPOINTMENT**

Advisory Board Member,
Master of Arts Degree Program
in Applied Archaeology at
California State University, San
Bernardino.

PROJECT EXPERIENCE (CONTINUED)

**Diablo Canyon Power Plant
San Luis Obispo County, California**

Mr. McLean performed cultural resources inventory of emergency sirens proposed for relocation. The study included monitoring of excavation in sensitive areas. Impacts to resources were successfully avoided. The client was Pacific Gas & Electric Company.

PRE-LSA PROJECT EXPERIENCE

SAN DIEGO COUNTY

**Imperial Beach Sand Replenishment Project, U.S. Army Corps of
Engineers, L.A. District
Imperial Beach, California**

Mr. McLean served as project archaeologist completing field studies and Section 106 compliance documents.

**Starwood Development (404 permit), U.S. Army Corps of Engineers,
L.A. District**

West and Central San Diego County, California. Mr. McLean was responsible for reviewing and approving archaeological studies involving the Harris Site Archaeological District.

**Ballast Point Dock Repair, U.S. Army Corps of Engineers, L.A.
District**

Oceanside, San Diego, California

Mr. McLean was responsible for field studies (both marine and terrestrial) and Section 106 compliance for impacts as a result of proposed dock repair at Ballast Point. Resources included a historic whaling station and portions of historic Fort Guajarras.

Additional San Diego County Projects

- Oceanside Harbor Maintenance
- San Luis Rey River Flood Control, Data Recovery Excavations
- Silver Strand Beach Sand Replenishment
- Joint Task Force-6 Border Fence (studies along border with Mexico)
- Tierrasanta Unexploded Ordnance (UXO) Detection and Removal
- Sports Arena Arco Station (Historic landfill studies)

SAN LUIS OBISPO COUNTY

- **Diablo Canyon Power Plant:** Mr. McLean performed a cultural resources inventory of emergency sirens proposed for relocation. The study included monitoring of excavation in sensitive areas.

PRESENTATIONS

Discussant: Symposium titled *San Diego: Border Town to Boomtown*. Society for Historical Archaeology Conference, Toronto, Canada, 2009.

Presenter: *Buried Sites Archaeology: Life by the Lakes in Laguna Canyon during the Middle and Late Holocene*. Society for American Archaeology Conference, Austin, Texas, 2007.

Presenter: *Buried Sites Archaeology: Life by the Lakes in Laguna Canyon during the Intermediate and Late Prehistoric Periods*. Southern California Academy of Sciences Conference, California State University, Fullerton, 2007.

Organizer and Chair: Symposium entitled *Culture Transformation along the Pacific Rim: Impacts and Influences as a Result of Conquest and Expansion by Non-Native Cultures in California*. Presenter: *Life on the Historic California Frontier and the Search for the Noble Stage Stop: Results of Excavations of a 19th Century Home and Stage Stop in San Timoteo Canyon*. Society for Historical Archaeology Conference, Williamsburg, Virginia, 2007.

Co-Organizer and Chair: Symposium entitled *Contributions to the Prehistory and History of the Southwest and California by the South Pacific Division of the U.S. Army Corps of Engineers*. Society for American Archaeology Conference, Milwaukee, Wisconsin, 2003.

Presenter: *Ordnance Detection and Removal and National Historic Preservation Compliance*. Society of Historical Archaeology Conference, Mobile, Alabama, 2002

Presenter: *Ordnance Detection and Removal and Compliance with Federal Preservation Law*. UXO/Countermine Forum, Orlando, Florida, 2002.

PRE-LSA PROJECT EXPERIENCE (CONTINUED)

Impacts to resources were successfully avoided. The client was Pacific Gas & Electric Company.

- **Montaña de Oro State Park:** Mr. McLean performed a survey of portions of the State Park in support of identification and disposal of unexploded ordnance as a result of amphibious landing training during WWII.

SANTA BARBARA COUNTY

- **Los Padres National Forest:** Mr. McLean was hired by the USDA Forest Service to perform a review of the Cultural Resources Program at the Forest.
- **Vandenberg Air Force Base:** Mr. McLean performed a survey and excavation with Westec and Harmsworth prior to construction of proposed projects on Base.
- **All American Pipeline:** Mr. McLean supervised surveys and excavations of several archaeological sites as part of required studies in response to proposed pipeline construction.
- **Goleta Sanitary District:** Mr. McLean participated in excavations of CA-SBA-46 prior to expansion of the district.

SAN LUIS OBISPO AND SANTA BARBARA COUNTIES

- **Coastal Aqueduct Project:** Mr. McLean reviewed and approved all cultural resources studies performed in accordance with 36 CFR Part 800. He implemented subsurface exploration strategies to identify buried cultural resources in depositional environments. Mr. McLean also performed consultation with Native Americans and the California Office of Historic Preservation.

ORANGE COUNTY

- **Talega Development:** As Compliance Manager at the U.S. Army Corps of Engineers, Mr. McLean reviewed and approved cultural resources studies for a prehistoric village site for compliance with Section 106 requirements.
- **U.S. Army Corps of Engineers 404 Permitting:** Mr. McLean has over 12 years experience with the Corps' Regulatory Program including permits issued by the Corps per Section 404 of the Clean Water Act. While employed with the Corps, Mr. McLean also drafted revisions to Appendix C (Historic Properties Regulation) of 33 CFR Part 325, Processing of Department of the Army Permits. Since coming to LSA, Mr. McLean has drafted conditioned 404 permit language employed by the Corps in issuing expedited

**PRESENTATIONS
(CONTINUED)**

Presenter: *Compliance with the National Historic Preservation Act and Clean Water Act*. Four Southern Tribes Cultural Resource Law Conference, Casa Grande, Arizona, 1999.

Presenter: *Compliance with the National Historic Preservation Act and Clean Water Act*. Orange County Chapter of the Association of Environmental Professionals, 1999.

Presenter: The Application of Archaeology to Forensic Settings: An MIA Recovery Mission in Viet Nam. Data Sharing Meeting, Santa Barbara (1998), Pacific Coast Archaeology meeting (1999), television interview in 1999 on KOCE (PBS), Real Orange, Veterans of Foreign Wars (2000), San Diego County Chapter of Association of Environmental Professionals (2008).

PRE-LSA PROJECT EXPERIENCE (CONTINUED)

permits, and has been designated by the Corps regarding several 404 permit projects as its representative in consultation with the State Historic Preservation Officer. Mr. McLean has extensive experience developing the Area of Potential Effects for permit projects and has provided instruction on Section 404 to Native American tribes.

- **Agency Consultation and Section 106 Compliance:** Mr. McLean has successful experience working with the BLM, the U.S. Forest Service, California State Parks, and the OHP. Mr. McLean completed several successful projects involving World War II training areas that are part of General Patton's Desert Training Center/California-Arizona Maneuver Area. The Forest Service contacted OHP requesting a recommendation of a person to independently provide oversight of two of their cultural resources programs. OHP recommended Mr. McLean who provided review and comment to the Forest Service. Mr. McLean has developed a very strong working relationship with the OHP over the last 15 years.

APPENDIX N

GEOTECHNICAL REPORT

GEOTECHNICAL INVESTIGATION,
Torrey Pines Road Slope Reconstruction,
Between Little Street and Roseland Drive,
La Jolla, San Diego, California

Prepared for:

City of San Diego
Engineering and Capital Projects
1010 2nd Street, Suite 1200
San Diego, California 92101

Project No. 040596-003

May 17, 2011



Leighton and Associates, Inc.



Leighton and Associates, Inc.

A LEIGHTON GROUP COMPANY

May 17, 2011

Project No. 040596-003

To: City of San Diego
Engineering and Capital Projects
1010 2nd Street, Suite 1200
San Diego, California 92101

Attention: Mr. William Mercer

Subject: Geotechnical Investigation, Torrey Pines Road Slope Reconstruction, Between Little Street and Roseland Drive, La Jolla, San Diego, California

In accordance with the request and authorization, we have conducted a geotechnical investigation of the southern slope along Torrey Pines Road between Little Street and Roseland Drive, in the La Jolla area of San Diego, California (Figure 1). The purpose of this geotechnical study was to evaluate the pertinent geotechnical conditions of the site and to provide preliminary conclusions and recommendations relative to the slope reconstruction and design of a proposed soil nail wall. The accompanying report presents a summary of our evaluation and provides geotechnical findings, conclusions, and recommendations relative to the proposed development.

Based on the results of our geotechnical investigation of the site, it is our professional opinion that the proposed improvement is feasible from a geotechnical standpoint, provided the conclusions and recommendations presented in this report are incorporated into the project plans and specifications and utilized during the grading and construction phases of site improvements. If you have any questions regarding our report, please do not hesitate to contact this office. We appreciate this opportunity to be of service.

Respectfully submitted

LEIGHTON AND ASSOCIATES, INC.

William D. Olson, RCE 45283
Associate Engineer

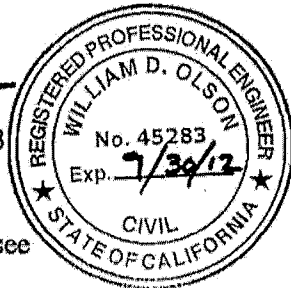

Distribution: (2) Addressee

Michael R. Stewart, CEG 1349
Vice President/Principal Geologist

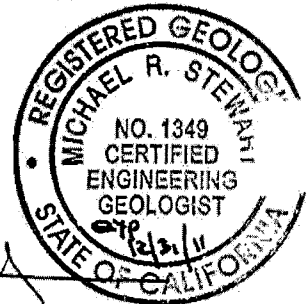

TABLE OF CONTENTS

<u>Section</u>	<u>Page</u>
1.0 INTRODUCTION	1
1.1 Introduction and Purpose.....	1
1.2 Scope of Services	1
1.3 Project Description and Background.....	3
1.4 Proposed Improvements	4
1.5 Field Exploration and Installation of Soil Nails	4
1.6 Soil Nail Testing	5
1.7 Laboratory Testing	5
2.0 SUMMARY OF GEOTECHNICAL CONDITIONS	6
2.1 Regional Geology	6
2.2 Site-Specific Geology	6
2.3 Geologic Structure.....	6
2.4 Ground Water	7
2.5 Faulting	7
2.5.1 Seismic Considerations	8
2.6 Slope Stability	9
3.0 CONCLUSIONS	11
4.0 RECOMMENDATIONS	12
4.1 Earthwork.....	12
4.1.1 Site Preparation	12
4.1.2 Excavation.....	12
4.1.3 Fill Placement and Compaction	12
4.2 Temporary Trench Excavation	13
4.3 Surface Drainage and Erosion.....	14
4.4 Foundation and Slab Considerations	14
4.4.1 Preliminary Foundation Design	14
4.4.2 Seismic Design Parameters	15
4.4.3 Setbacks for Settlement Sensitive Improvements From Slope Faces ..	15
4.5 Lateral Earth Pressures and Retaining Wall Design Considerations.....	16
4.6 Preliminary Soil Nail Design Parameters.....	17
4.7 Concrete Flatwork	18
4.8 Control of Ground water and Surface Water	18
4.9 Graded Slopes	19
4.10 Plan Review and Construction Observation	19
5.0 LIMITATIONS.....	20



TABLE OF CONTENTS (Continued)

Tables

- Table 1 - Seismic Parameters for Nearest Active Faults - Page 8
- Table 2 - Summary of Factors of Safety for Slope Stability - Page 10
- Table 3 - 2010 CBC Seismic Parameters - Page 15
- Table 4 - Static Equivalent Fluid Weight (pcf) - Page 16
- Table 5 - Preliminary Soil Nail Design Parameters - Page 17

Figures

- Figure 1 - Site Location Map - Page 2
- Figure 2 - Detail of Constructed Soil Nails - (end of text)

Plates

- Plate 1 - Geotechnical Map - In Pocket
- Plate 2 - Cross Sections - In Pocket

Appendices

- Appendix A - References
- Appendix B - Boring Logs
- Appendix C - Test Results of Preliminary Soil Nailing
- Appendix D - Laboratory Testing Procedures and Test Results
- Appendix E - Site Seismic Analysis
- Appendix F - Slope Stability Analyses
- Appendix G - General Earthwork and Grading Specifications for Rough Grading



1.0 INTRODUCTION

1.1 Introduction and Purpose

This report presents the results of our geotechnical investigation for the proposed slope repair improvements located along a portion of Torrey Pines Road in La Jolla, California (Figure 1). The purpose of our study was to evaluate the existing geotechnical conditions of the site and to provide preliminary conclusions and recommendations relative to the proposed slope improvements. This report presents a summary of the findings, conclusions, and recommendations of our geotechnical investigation for the site.

1.2 Scope of Services

Our scope of services performed during this geotechnical investigation included the following:

- Review of available pertinent, published and unpublished geotechnical literature and maps (Appendix A).
- Field reconnaissance of the existing onsite geotechnical conditions.
- Subsurface exploration to collect samples and determine the physical properties beneath the face of the slope.
- Installation of two soil-nails for in-situ proof and performance testing (see Figure 2).
- Laboratory testing of soil samples obtained from the subsurface exploration.
- Compilation and analysis of the geotechnical data obtained from the field investigation and laboratory testing.
- Preparation of this report presenting our findings, conclusions, and geotechnical recommendations relative to the proposed project. The recommendations include our General Earthwork and Grading Specifications for Rough Grading presented in Appendix D.



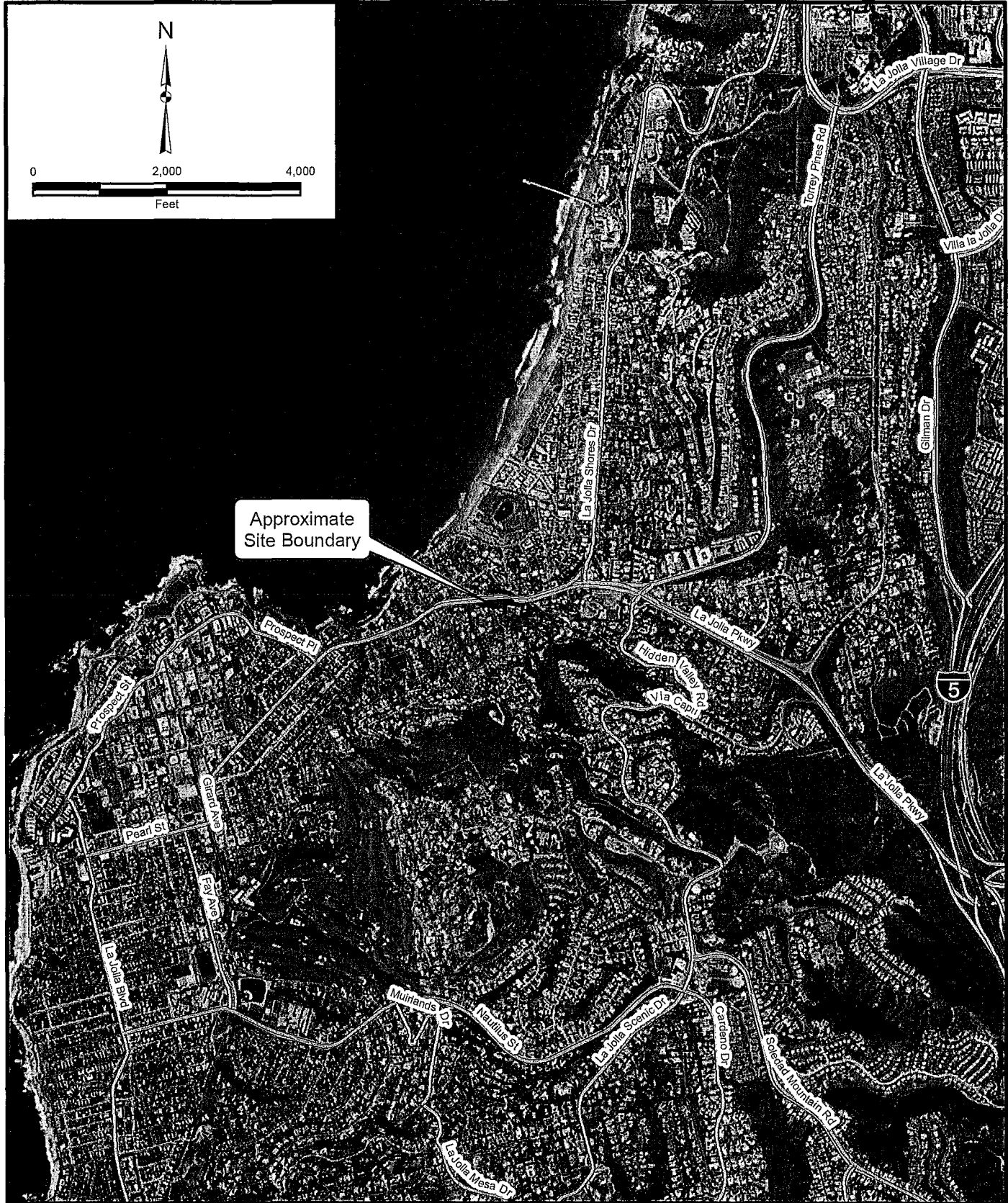

Project: 040596-003 Eng/Geol: WDO/MRS

Scale: 1" = 2,000' Date: May, 2011

Base Map: ESRI Resource Center, 2010
 Thematic Info: Leighton
 Author: (mmurphy)

SITE LOCATION MAP

Torrey Pines Road Slope Reconstruction
 Between Little Street and Roseland Drive
 San Diego, California

Figure 1



Leighton

1.3 Project Description and Background

A cut slope, approximately 350-foot long, and up to 30-foot in height, along the south side of Torrey Pines Road, between Little Street and Roseland Drive has been deteriorating over time and needs to be improved. The proposed project will stabilize the slope with a new retaining wall structure and add a pedestrian sidewalk. Originally, cut portions of the slope were covered with a gunite surface. Much of the original gunite facing has spalled and cleared away, and the integrity of the remaining portions are threatened by erosional cavities that have developed behind the gunite facing. As shown on Plate 1, the existing site topography of the slope, essentially starting at the back of the curb, is steep (i.e., approximately 1 to 1, horizontal: vertical) with varying densities of vegetation in exposed soil areas. Currently, the top of the slope, as defined on Plates 1 and 2, varies from 10 to 25 feet back of curb. Utilities within the project site included street lighting, telephone, television cable, water, gas and storm drain lines. The City of San Diego provided the base map including the right-of-way (ROW) lines presented on the project drawings. Please note that additional surveying is needed to confirm the ROW and more precise topography prior to preparation of final plans.

In April 2000, Geotechnics Incorporated (Geotechnics) performed a geotechnical evaluation of the site. The report presented preliminary geotechnical recommendations and various alternative "concept level design" options for stabilization and erosion protection of the subject slope. Based on the results of that study, the City selected a "Loffelstein" Erosion Control Wall option (i.e., a variation of the Mechanically Stabilized Wall Option with a plantable wall surface) which utilizes geogrid reinforcement. With the recognition that the design by Geotechnics was a "concept level design", the City of San Diego then requested Leighton to prepare a 30 Percent Design and Alternatives Evaluation prior to initiating the final design. Considering the relatively large quantity of excavation export and selected fill import needed to construct a geogrid reinforced wall, the City of San Diego requested that another alternative (i.e., soil nail reinforcement system with plantable facing blocks) be evaluated. Subsequently, the soil nail reinforcement system with plantable facing blocks alternative was selected, and a 95 percent design was prepared and issued in September 2002.

In September 2010, the City of San Diego requested a modification in the selected alternative. The modification consisted of the elimination of the outer Verdura "plantable" wall section, and use of a standard soil nail wall with an outer Boulderscape or Rock Carve surface, which are now commonly constructed.



1.4 Proposed Improvements

Based on the recently requested modifications, the proposed improvements include a new soil nail retaining wall with an outer Boulderscape or Rock Carve surface to stabilize the slope, a new sidewalk, the replacement of a water main beneath and behind the new retaining wall, and associated drainage and landscaping improvements.

Construction will include an excavation at the toe of the slope to achieve the required space for the sidewalk, removal of sloughing soil and debris off of slope face, and installation of permanent soil-nails wall with an outer Boulderscape or Rock Carve surface (Plate 2, Cross Sections). Approximately 780 cubic yards of soil will be exported from the site. The soil-nails, up to 40 feet in length, will be installed into the slope at an angle of approximately 15 degrees below horizontal. Horizontal and vertical spacing of the soil-nails will be approximately 6 feet. Roughly 250 soil-nails will be installed to construct the permanent wall.

As indicated on the preliminary design document (Leighton, 2002b), the proposed construction staging area is located directly north of the project site. The area is within the Torrey Pines Road right-of-way based on our research of San Diego County Assessors Map, Book 346, Page 48. It should be noted that we anticipate most or all work will be performed at night based on the volume of traffic during normal business hours. The contractor will be responsible for submitting the traffic control plan(s) for approval, and will obtain all the required city permits.

1.5 Field Explorations and Installation of Soil Nails

On April 27, 2011, we performed a site reconnaissance. Field observations indicate that the general site conditions of the site remain relatively the same as encountered in early 2002 with the exception of continuing surface erosion of the slope face.

Our original field exploration, performed on February 17, 2002, consisted of the excavation, logging, and sampling of two (2) small diameter borings, approximately 6 inches in diameter, advanced into the slope face at approximately Sta. 28+00 and Sta. 29+75 using a track-mounted air percussion drill rig. The purpose of these borings were to collect representative soil samples for laboratory testing to evaluate the physical characteristics and engineering properties of the onsite soils pertinent to the proposed improvements, and to construct two soil-nails for field-testing. The borings, drilled diagonally, were advanced to approximate 15 feet beyond the existing slope face at an approximate angle of 18-degrees below horizontal. During that field exploration, we also installed test soil nails into the boreholes for field testing. Condon Johnson performed the drilling, construction of the soil-nails, and the associated field-testing. The relatively undisturbed soil samples



were obtained using a 5 1/4 inch ID rock core barrel. Boring logs are presented in Appendix B. The approximate location of the boring is shown on the Geotechnical Map (Plate 1).

The previous subsurface explorations performed by Geotechnics, as referenced above, included the excavation, logging and sampling of five shallow test pits (i.e., T-1 through T-5). Depth of the exploration trenches ranged from 1 to 3 feet below the existing slope face ground surface. Logs and approximate location of the test pits are presented in Appendix B.

1.6 Soil Nail Testing

As discussed above, Condon Johnson constructed two test soil-nails immediately following the drilling and sampling activities in general conformance with the NTIS, Manual for Design and Construction Monitoring of Soil-Nail Walls (NTIS 1996). Details of the test soil-nails (i.e., reinforcement and grouted lengths) are shown on Figure 2. On February 27, 2002, proof testing was performed on both soil-nails and a performance test was conducted the soil-nail at Sta. 29+75. The estimated design load of the soil-nail assumed to be at least 20 kips. All field-testing was performed in accordance with Recommendations for Prestressed Rock and Soil Anchor developed by the Post-Tensioning Institute (PTI). Results of the testing indicated that the soil-nails, as-constructed, will yield the assumed design load of 20 kips. The results of field-testing are included in Appendix C.

1.7 Laboratory Testing

Laboratory testing was performed on representative soil samples and included moisture content, particle size analysis, Atterberg limits, and engineering strength parameters of the subsurface soils. A discussion of the laboratory tests performed and a summary of the laboratory test results are presented in Appendix D. In-situ moisture test results are provided on the boring logs (Appendix B).



2.0 SUMMARY OF GEOTECHNICAL CONDITIONS

2.1 Regional Geology

The subject site is located in the coastal section of the Peninsular Range Province, a geomorphic province with a long and active geologic history throughout Southern California. During the last 54 million years, the area known as the "San Diego Embayment" has undergone several episodes of marine inundation and subsequent marine regression, resulting in the deposition of a thick sequence of marine and nonmarine sedimentary rocks on the basement rock of the Southern California batholith.

Gradual emergence of the region from the sea occurred in Pleistocene time, and numerous wave-cut platforms, most of which were covered by relatively thin marine and nonmarine terrace deposits, formed as the sea receded from the land. Accelerated fluvial erosion during periods of heavy rainfall, coupled with the lowering of the base sea level during Quaternary times, resulted in the rolling hills, mesas, and deeply incised canyons which characterize the landforms we see in the general vicinity of the site today.

2.2 Site-Specific Geology

In summary, the site is generally underlain by the Upper Cretaceous Point Loma Formation (see Plate 1). The Point Loma Formation typically consists of interbedded olive green claystone and siltstones (i.e., roughly 80 percent), and dusky-yellow silty medium-grained sandstone (i.e., roughly 20 percent) (Kennedy, 1975). Both the interbedded claystones and siltstones, and the sandstones are moderately cemented and hard to very hard. Excavation in the cemented sandstone may be very difficult and require heavy ripping or breaking.

As anticipated, the subsurface soils encountered during exploration or boring activities consisted predominantly of formational siltstones and sandstones. It should be noted that the siltstone and claystone materials are highly fractured at the slope face and are capable of generating medium to very highly expansive soils (Geotechnics, 2000).

2.3 Geologic Structure

With regard to geologic structure, the preliminary geotechnical investigation prepared by Geotechnics reported the following:

"The subject site is located within the Rose Canyon fault zone between the mapped traces of the Rose Canyon fault to the east and the Mount Soledad fault to the west (Kennedy, 1975). As a result of local uplift along these



faults, the sandstone and shale beds of the Point Loma Formation at the site dip between 25 and 45 degrees to the southeast. The section of Torrey Pines Road which includes the subject site runs east-west. Therefore, the sandstone and claystone/siltstone beds dip into the slope. As mentioned previously, the claystone and siltstone beds are highly fractured. The fractures are perpendicular to bedding planes and are spaced less than 1 inch apart. These fractures are open and loose in the outer 3 to 4 feet of the slope face. Excavations into the slope indicate the fractures become tight approximately 4 to 5 feet into the slope face. The claystone and siltstone beds are also thinly bedded and fissile, and where weathered they tend to separate along bedding planes." (Geotechnics, 2000).

2.4 Ground Water and Surface Water

Ground water was not encountered during our site explorations or in the previous investigation by Geotechnics. However, future perched groundwater could develop as a result of rainfall, irrigation and changes in site drainage. Ground water is not expected to impact the proposed improvements if the recommendations regarding drainage outlined in this report are implemented.

No indication of surface water or evidence of surface ponding was encountered during our current or the previous field investigations. However, surface water may drain as sheet flow across the relatively level portion of the site during rainy. Backdrains should be provided for all retaining walls.

2.5 Faulting

Our discussion of faults on the site is prefaced with a discussion of California legislation and state policies concerning the classification and land-use criteria associated with faults. By definition of the California Mining and Geology Board, an active fault is a fault which has had surface displacement within Holocene time (about the last 11,000 years). The State Geologist has defined a potentially active fault as any fault considered to have been active during Quaternary time (last 1,600,000 years) but that has not been proven to be active or inactive. This definition is used in delineating Fault-Rupture Hazard Zones as mandated by the Alquist-Priolo Earthquake Fault Zoning Act of 1972 and as most recently revised in 1997. The intent of this act is to assure that unwise urban development does not occur across the traces of active faults. Based on our review of the Fault-Rupture Hazard Zones, the site is located within the Rose Canyon Fault Zone, a Fault-Rupture Hazard Zone as created by the Alquist-Priolo Act (Hart, 1997).



Evidence of faulting was not encountered during our field exploration; however, based on review of the Geologic Hazards SanGIS Map, the main trace of the Rose Canyon Fault may be located directly beneath the site or immediately east of the site with possible minor discontinuous fault also present beneath the site. In addition, the Mt. Soledad fault, an active fault within the Rose Canyon Fault Zone, is reportedly located roughly 600 feet west of the site (Geotechnics, 2000). Because of the known active faults near and possibly beneath the site, the potential for surface rupture at the site is considered high and the final design should address this issue (Geotechnics, 2000).

The possibility of and impacts of surface ruptures should be considered in the design of the new retaining wall structure, or permanent soil-nails wall. In general, geologic mapping will be done during the construction process to identify any fault zones. If significant zones of faulting are identified during construction, additional soils nails and isolation joints should be constructed into the permanent wall to provide relative flexibility.

2.5.1 Seismic Considerations

Our seismic evaluation indicated that the Rose Canyon Fault Zone is the "active" fault considered having the most significant effect for the site from a design standpoint. A maximum moment magnitude 7.2 on the fault could produce an estimated peak horizontal ground acceleration of 0.52g. Table 1 identifies the site-specific peak horizontal ground accelerations for the active faults nearest the site.

Fault	Distance from Fault to Site (miles)	Maximum Moment Magnitude	Peak Horizontal Ground Acceleration (g)
Rose Canyon	Less than 1.0	7.2	0.52
Coronado Bank-Aqua Blanca	13	7.6	0.23
Newport- Inglewood (Offshore)	23	7.1	0.11

Secondary effects associated with severe ground shaking following a relatively large earthquake which may affect the site include ground lurching and shallow



ground rupture, soil liquefaction and dynamic settlement, seiches and tsunamis. These secondary effects are discussed below.

The principal seismic considerations for most structures in southern California are surface rupturing of fault traces and damage caused by ground shaking or seismically induced ground settlement. The possibility of damage due to ground rupture is considered low since active faults are not known to cross the site. The seismic hazard most likely to impact the site is ground-shaking resulting from an earthquake on one of the major regional faults. The effects of seismic shaking can be reduced by adhering to the most recent edition of the California Building Code and design parameters of the Structural Engineers Association of California.

Liquefaction of cohesionless soils can be caused by strong vibratory motion due to earthquakes. Research and historical data indicate that loose granular soils underlain by a near-surface ground water table are most susceptible to liquefaction, while the stability of most silty clays and clays is not adversely affected by vibratory motion. Because of the dense nature of the underlying formational material and lack of a shallow permanent groundwater table, it is our opinion that the potential for liquefaction or seismically induced dynamic settlement at the site due to the design earthquake is very low. Hazards from seiches and tsunamis are not present as the site is located away from the immediate coastal area and there are no large standing bodies of water in or near the site.

2.6 Slope Stability

To evaluate the stability of the existing slopes and proposed soil-nail wall, and to determine the factor of safety to resist deep-seated instability, the computer program GSTABL7 with STEDwin (Gregory, 2001) was used. Profiles analyzed included cross-sections A-A, B-B and C-C, as present on Plate 2. The analyzed scenarios included a static drained condition for existing slopes, and the proposed soil-nail alternative. In addition, we analyzed the wall under a pseudo-static (seismic) condition. Soil properties used in the analyses (i.e., soil unit weights and soil strength properties) were obtained from the laboratory testing, experience with similar materials, and our professional experience. In summary, the in situ soil strength parameters included a conservative friction angle of 34 degrees and cohesion of 60 psf, and compacted fill strength parameters included a friction angle of 32 degrees and cohesion of 0 psf. The data for slope stability analyses are presented in Appendix F.

For pseudo-static analysis, the cross-sections were analyzed a horizontal pseudo-static coefficient of 0.15 was selected based on the range presented by Seed as reproduced in California Division of Mines and Geology Special Publication 117 – Guidelines for Evaluating and Mitigating Seismic Hazards in California (CDMG, 1997). According to



Seed, a coefficient range of 0.10 to 0.15 corresponds to maximum earthquake magnitudes of M6.5 to M8.25. Considering the location of the site and the Rose Canyon Fault Zone the upper bound of the range, $k_H = 0.15$, was elected for analysis.

Table 2, as follows presents the results of our stability analysis for the static and pseudo-static (seismic) scenario. Only circular failure surfaces were considered in our analysis.

Location	Proposed Soil-Nail Wall		Existing Condition
	Static	Pseudo-Static $k_H = 0.15$	
A-A	1.71	1.36	1.17
B-B	1.63	1.30	1.05
C-C	1.62	1.30	1.07

Based on our analysis, the existing slope condition cross-sections possess factors of safety less than 1.5 for static conditions. As for the proposed reinforcing soil-nail wall, the factors of safety will be greater than 1.5 for static conditions. For the horizontal coefficient of $k_H = 0.15$, the analyzed cross-sections are above the pseudo-static factor of safety of 1.15, as recommended by Seed (CDMG, 1997).



3.0 CONCLUSIONS

Based on the results of our geotechnical investigation of the site, it is our opinion that the proposed improvements, consisting of soil-nail wall, sidewalk and replacement water main are feasible from a geotechnical standpoint, provided the following conclusions and recommendations are incorporated into the project plans and specifications.

The following is a summary of the geotechnical factors that may affect development of the site.

- Based on our review of the Fault-Rupture Hazard Zones, the site is located within the Rose Canyon Fault Zone and the main trace Rose Canyon Fault or minor fault traces may be located directly beneath the site and/or immediately east of the site. Therefore, geologic mapping will be done during the construction process to identify any fault zones. If significant zones of faulting are identified during construction, additional soils nails and isolation joints will be constructed into the permanent wall to provide relative flexibility.
- Based on our subsurface exploration, laboratory testing, the subsurface Point Loma Formation material beneath the site consists of a hard siltstone and moderately cemented sandstone. Excavation in the cemented sandstone may be difficult and require ripping with a dozer. The siltstone and claystone material is capable of generating medium to highly expansive soils and may not be suitable for reuse in the geogrid alternative.
- Near surface ground water or seepage was not encountered during our investigation of the site; however, ground water seepage should be expected during periods of precipitation. Drainage devices (backdrains) should be installed behind all walls.
- Based on our analysis, the existing slope possesses factors of safety less than 1.5 for static conditions. As for the proposed improvements with the new soil-nail reinforcing wall, the factors of safety will be greater than 1.5 for static conditions. For the pseudo-static condition with a horizontal coefficient (k_H) of 0.15, the analyzed cross-sections will have a factor of safety of greater than 1.15, as recommended by Seed (CDMG, 1997).



4.0 RECOMMENDATIONS

4.1 Earthwork

We anticipate that earthwork at the site will consist of site preparation, grading (primarily excavation and exporting of soil) and installation of soil-nails. We recommend that earthwork on the site be performed in accordance with the City of San Diego requirements, the following recommendations, and the General Earthwork and Grading Specifications for Rough Grading included in Appendix D. In case of conflict, the following recommendations shall supersede those presented in Appendix D.

4.1.1 Site Preparation

Prior to grading, all areas to receive structural fill, engineered structures, or surface improvements should be cleared of surface and subsurface obstructions, including any existing debris; asphalt; concrete; abandoned underground utility lines; loose, desiccated, or disturbed fill soils; and stripped of vegetation. Removed vegetation and debris should be properly disposed off site.

4.1.2 Excavation

Excavations of the onsite materials may generally be accomplished with conventional heavy-duty earthwork equipment. Moderate ripping of cemented formational materials may be needed. In accordance with OSHA requirements, excavations deeper than 5 feet should be shored or be laid back in accordance with Section 4.2.

4.1.3 Fill Placement and Compaction

All areas to receive fill and/or other surface improvements should be scarified to a minimum depth of 6 inches, brought to a minimum of 2 percent above the optimum moisture content, and recompacted to at least a 90 percent relative compaction (based on ASTM Test Method D1557).

The granular onsite soils are generally suitable for re-use as compacted fill provided they are free of organic material, debris, and cobbles larger than 8 inches in maximum dimension. All fill soils should be brought to a minimum of 2 percent over the optimum moisture content and compacted in uniform lifts. The upper 12 inches of subgrade and all aggregate base materials should be compacted to at least 95 percent beneath vehicular pavements.



The optimum lift thickness required to produce a uniformly compacted fill will depend on the type and size of compaction equipment used. In general, fill should be placed in lifts not exceeding 8 inches in thickness. Fills placed on slopes steeper than 5:1 (horizontal to vertical) should be keyed and benched into competent formational soils as indicated in the General Earthwork and Grading Specifications for Rough Grading presented in Appendix G.

Placement and compaction of fill should be performed in general accordance with the current City of San Diego grading ordinances, sound construction practice, and the General Earthwork and Grading Specifications for Rough Grading presented in Appendix G.

4.2 Temporary Trench Excavations

Sloped excavations may be utilized when adequate space allows. Based on findings, we provide the following recommendations for sloped excavations in fill soils or competent formational materials without seepage conditions.

Excavation Depth Below Adjacent Surface (feet)	Maximum Slope Ratio In Fill Soils	Maximum Slope Ratio In Competent Formation
0-5	¾:1 (H:V)	Vertical
5-10	1:1	¾:1
10-20	1:1	¾:1

Excavations greater than 20 feet in height will require an alternative sloping plan or shoring plan prepared by a California registered civil engineer. The above values are based on the assumption that no surcharge loading or equipment will be placed within 10 feet of the top of slope. All excavations should comply with OSHA requirements. Care should be taken during excavation adjacent to the existing structures so that undermining does not occur. The contractor's "competent person" should review all excavations on a daily basis for signs of instability.



4.3 Surface Drainage and Erosion

Surface drainage should be controlled at all times. The proposed structure should have appropriate drainage systems to collect runoff. Positive surface drainage should also be provided to direct surface water away from proposed structures or the top of slopes toward suitable drainage facilities. Positive drainage may be accomplished by providing a minimum 2 percent gradient from the structure or slope for a distance of at least 5 feet. In general, ponding of water must be avoided adjacent to structures, tops of slopes, or pavements.

In order to help reduce the potential for excessive erosion of graded slopes, we recommend berms and/or swales be provided along the top of the slopes and drainage directed such that surface runoff on the slope faces is minimized. Protective measures to mitigate excessive site erosion during construction should also be implemented in accordance with the latest pertinent grading ordinances.

4.4 Foundation Considerations

Foundations for small structures, if any, should be designed in accordance with structural considerations and the following recommendations. These recommendations assume that the soils encountered within 5 feet of the finish grade or within 3 feet of the foundation are granular with a very low to low potential for expansion. If soils other than very low or low expansive soils are encountered during site grading, additional foundation design will be necessary. These recommendations should be confirmed after the completion of grading based on the actual as-graded geotechnical conditions.

4.4.1 Preliminary Foundation Design

Small structure, if any, may be designed by the structural engineer utilizing the following geotechnical parameters. For isolated square and continuous foundations, an allowable bearing capacity of 2,000 psf may be utilized for footings with a minimum width of 18 inches at a depth of at least 24 inches below the adjacent grade. The allowable pressure may be increased by one-third when considering loads of short duration such as wind or seismic forces.



4.4.2 Seismic Design Parameters

The effect of seismic shaking may also be mitigated by adhering to the California Building Code or state-of-the-art seismic design parameters of the Structural Engineers Association of California. Provided below are the seismic design parameters for the project determined in accordance with the 2010 CBC (CBSC, 2010) and the USGS Ground Motion Parameter Calculator (Version 5.1.0).

Description	Values		CBC Reference
Site Class	C		Table 1613.5.2
Short Period Spectral Acceleration	S_s	1.703	Figure 1613.5(3)
1-Second Period Spectral Acceleration	S_1	0.677	Figure 1613.5(4)
Short Period Site Coefficient	F_a	1.0	Table 1613.5.3(1)
1-Second Period Site Coefficient	F_v	1.3	Table 1613.5.3(2)
Modified Short Period Spectral Acceleration	S_{MS}	1.703	Equation 16-37
Modified 1-Second Period Acceleration	S_{M1}	0.881	Equation 16-38
Design Short Period Spectral Acceleration	S_{DS}	1.135	Equation 16-39
Design 1-Second Period Spectral Acceleration	S_{D1}	0.587	Equation 16-40

4.4.3 Setbacks for Settlement Sensitive Improvements From Slope Faces

Foundations or settlement-sensitive improvements should be setback from slopes in accordance with the minimum City of San Diego code regulations, CBC requirements, or the following criteria, whichever is greater. We recommend a minimum horizontal setback distance from the face of descending slopes for all structural footings and settlement-sensitive structures. This distance is measured from the outside bottom edge of the footing or improvement, horizontally to the slope face (or to the face of a retaining wall) and should be a minimum of $H/3$, where H is the slope height (in feet). The setback should not be less than 10 feet.

Please note that the soils within the structural setback area possess poor lateral stability, and improvements (such as retaining walls, utility lines, sidewalks, fences, and other improvements) constructed within this setback area may be subject to lateral movement and/or differential settlement. These improvements should be designed so as to accommodate potential movement due to slope creep.



Such design typically includes the frequent use of construction joints, and soft-scape between features. Structures that cannot tolerate minor lateral and vertical movement should not be located in this slope setback zone.

4.5 Lateral Earth Pressures and Retaining Wall Design Considerations

For the design of smaller retaining walls (if any), the following lateral earth pressure values presented on Table 4 for level or sloping backfill are recommended for walls backfilled with very low to low expansive on-site soils or approved granular material of very low to low expansion potential.

Conditions	Level	2:1 Slope
Active	35	55
At-Rest	55	65
Passive	350 (Maximum of 3 ksf)	150 (sloping down)

Unrestrained (yielding) cantilever walls up to 6 feet in height should be designed for an active equivalent pressure value provided above. In the design of walls restrained from movement at the top (nonyielding) such as basement walls, the at-rest pressures should be used. If conditions other than those covered herein are anticipated, the equivalent fluid pressure values should be provided on an individual case basis by the geotechnical engineer. A surcharge load for a restrained or unrestrained wall resulting from automobile traffic may be assumed to be equivalent to a uniform pressure of 75 psf, which is in addition to the equivalent fluid pressure given above. For other uniform surcharge loads, a uniform pressure equal to $0.35q$ should be applied to the wall (where q is the surcharge pressure in psf). The wall pressures assume walls are backfilled with free draining behind walls. A typical drainage design is presented in Appendix G.

Wall backfill should be compacted by mechanical methods to at least 90 percent relative compaction (based on ASTM Test Method D1557). Wall footings should be designed in accordance with the foundation design recommendations and reinforced in accordance with structural considerations. For all retaining walls, we recommend a minimum horizontal distance from the outside base of the footing to daylight of 10 feet.



Lateral soil resistance developed against lateral structural movement can be obtained from the passive pressure value provided above. Further, for sliding resistance, the friction coefficient of 0.3 may be used at the concrete and soil interface. These values may be increased by one-third when considering loads of short duration including wind or seismic loads. The total resistance may be taken as the sum of the frictional and passive resistance provided that the passive portion does not exceed two-thirds of the total resistance.

The geotechnical consultant should approve any backfill materials that will be utilized prior to the backfill placement operations. It is the contractor's responsibility to provide representative samples of the selected backfill material.

4.6 Preliminary Soil Nail Design Parameters

For preliminary design and an initial evaluation of a soil nail wall system, the following soil properties are recommended for use:

Table 5 Preliminary Soil Nail Design Parameters	
Soil Parameters	Design Value
Internal Friction Angle, (degrees)	34
Cohesion, (psf)	170
Total Unit Weight, (pcf)	120
Ultimate Bond Stress (psi)	20 to 30

It should be noted that the actual bond stress for the soil nails will be highly dependent on the methods of construction along the expertise of the contractor. In addition, the bond stress can be increased by pressure grouting. The selected design bond stress should be verified by field testing. An appropriate testing and inspection program should be provided as part of the project plans.



In order to provide adequate drainage behind soil nail walls, we recommend vertical drainage panels be installed as strips between rows of soil nails. The drainage panels should be connected at the base of the wall and outletted to a collective drainage system or to weephole at the base of the wall. Panel drains should be terminated near the top of the wall and should not be exposed above the top of wall.

4.7 Concrete Flatwork

Concrete sidewalks and other flatwork (including construction joints) should be designed by the project civil engineer and should have a minimum thickness of 4 inches. For all concrete flatwork, the upper 12 inches of subgrade soils should be moisture conditioned to at least 3 percent or above optimum moisture content and compacted to at least 90 percent relative compaction based on ASTM Test Method D1557 prior to the concrete placement.

4.8 Control of Ground Water and Surface Waters

Regarding Low Impact Development (LID) measures, we are of the opinion that bioswales, infiltration basins, and other onsite storm water retention and infiltration systems can potentially create adverse perched ground water conditions both on-site and off-site. Therefore, given the site geologic conditions, relatively low infiltration rate, and project type, infiltration type LID measures are not considered to be appropriate for this site and project.

Surface drainage should be controlled at all times and carefully taken into consideration during precise grading, landscaping, and construction of site improvements. Positive drainage should be provided to direct surface water towards the street or suitable drainage devices. Ponding of water adjacent to structures or pavements should be avoided. The performance of structural foundations is dependent upon maintaining adequate surface drainage away from structures.

Water should be transported off the site in approved drainage devices or unobstructed swales. We recommend a minimum flow gradient for unpaved drainage within 5 feet of structures of 2 percent sloping away.

The impact of heavy irrigation or inadequate runoff gradient can create perched water conditions, resulting in seepage or shallow ground water conditions where previously none existed. Maintaining adequate surface drainage and controlled irrigation will significantly reduce the potential for nuisance-type moisture problems. To reduce differential earth movements such as heaving and shrinkage due to the change in moisture content of foundation soils, which may cause distress to a structure and improvements, moisture



content of the soils surrounding the structure should be kept as relatively constant as possible. Below grade planters should not be situated adjacent to structures or pavements unless provisions for drainage such as catch basins and drains are made.

All area drain inlets should be maintained and kept clear of debris in order to function properly. In addition, landscaping should not cause any obstruction to site drainage. Rerouting of drainage patterns and/or installation of area drains should be performed, if necessary, by a qualified civil engineer or a landscape architect.

4.9 Graded Slopes

It is recommended that all graded slopes within the development be planted with drought-tolerant ground cover vegetation as soon as practical to protect against erosion by reducing runoff velocity. Deep-rooted vegetation should also be established to protect against surficial slumping. Oversteepening of existing slopes should be avoided during fine grading and construction unless supported by appropriately designed retaining structures.

We recommend terrace drains on the slopes be designed by the civil engineer and be constructed in accordance with current City of San Diego specifications. Design of surface drainage provisions is within the purview of the project civil engineer.

4.10 Plan Review and Construction Observation

Final project drawings should be checked by Leighton and Associates prior to grading or construction to see that the recommendations in this report are incorporated in project plans. Construction observation of all onsite excavations and field density testing of all compacted fill should be performed by a representative of this office. We recommend that a geologist map all excavations during grading for the presence of potentially adverse geologic conditions. All footing excavations should be reviewed by this office prior to placing steel or concrete.



5.0 LIMITATIONS

The conclusions and recommendations in this report are based in part upon data that were obtained from a limited number of observations, site visits, excavations, samples, and tests. Such information is by necessity incomplete. The nature of many sites is such that differing geotechnical or geological conditions can occur within small distances and under varying climatic conditions. Changes in subsurface conditions can and do occur over time. Therefore, the findings, conclusions, and recommendations presented in this report can be relied upon only if Leighton and Associates has the opportunity to observe the subsurface conditions during grading and construction of the project, in order to confirm that our preliminary findings are representative for the site.



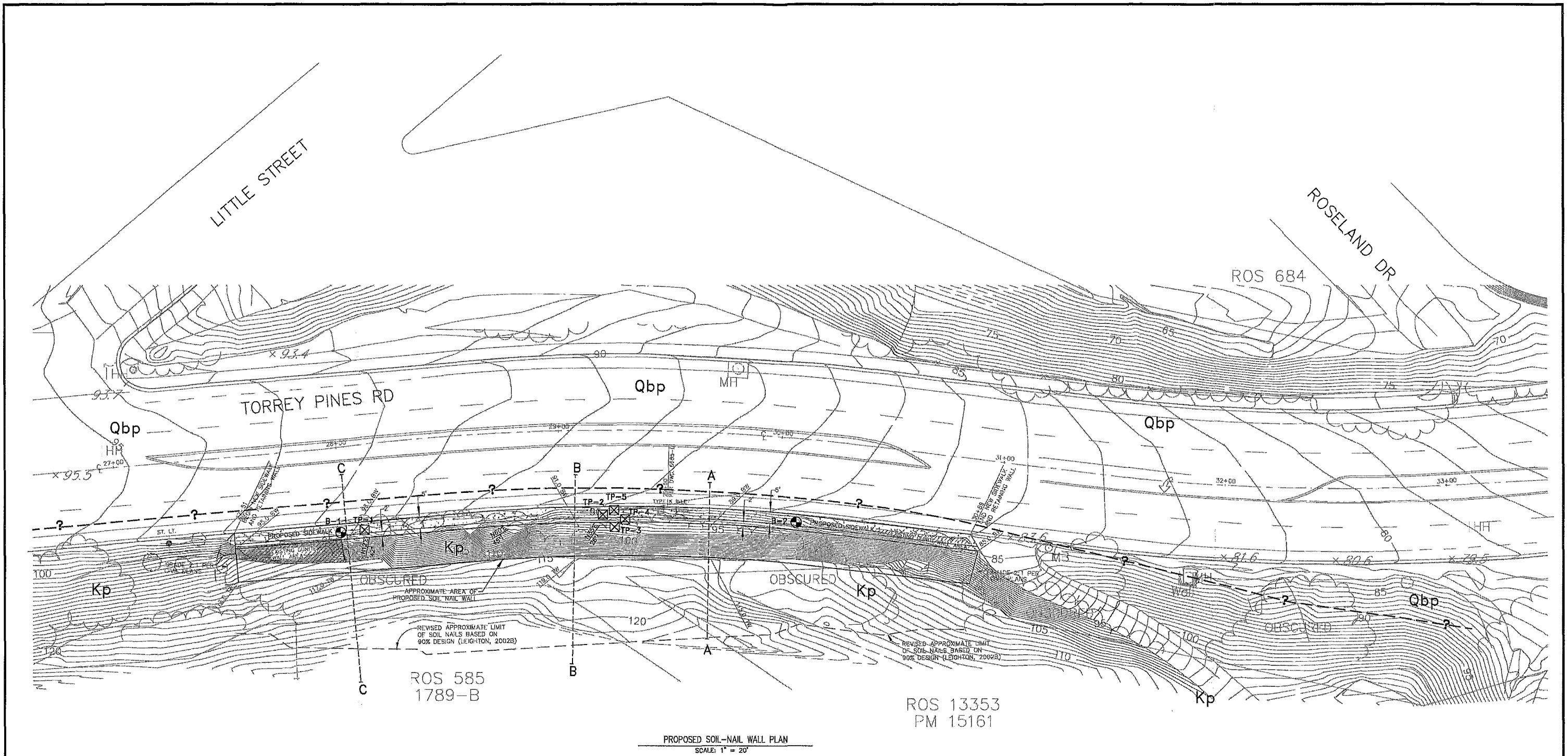

PROPOSED SOIL-NAIL WALL PLAN
SCALE: 1" = 20'

LEGEND

- Qbp QUATERNARY BAY POINT FORMATION, DASHED WHERE APPROXIMATE QUERIED WHERE UNCERTAIN
- Kp CRETACEOUS POINT LOMA FORMATION, DASHED WHERE APPROXIMATE QUERIED WHERE UNCERTAIN
- ?-? GEOLOGIC CONTACT, DASHED WHERE APPROXIMATE QUERIED WHERE UNCERTAIN
- ⊙ B-2 APPROXIMATE LOCATION OF BORING/SOIL NAIL BY LEIGHTON AND ASSOCIATES, THIS INVESTIGATION
- ⊗ TP-5 APPROXIMATE LOCATION OF TEST PITS BY GEOTECHNICS, 2000
- ⊠ 20' APPROXIMATE LOCATION OF BEDDING ATTITUDE TAKEN BY GEOTECHNICS, 2000

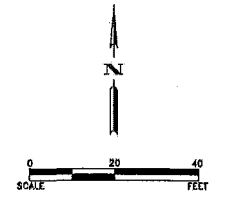

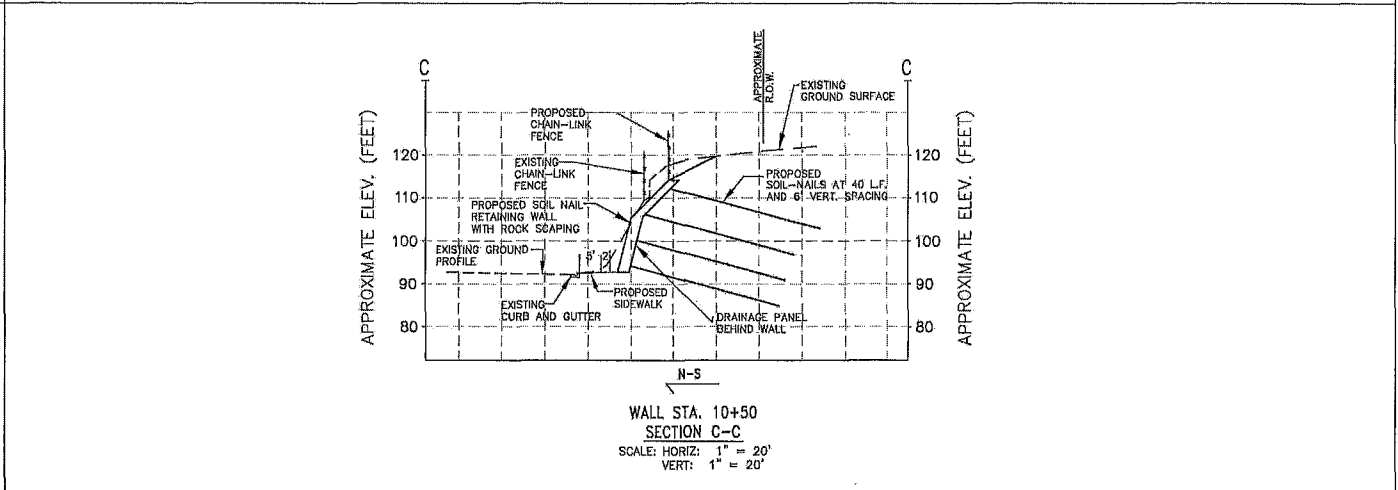
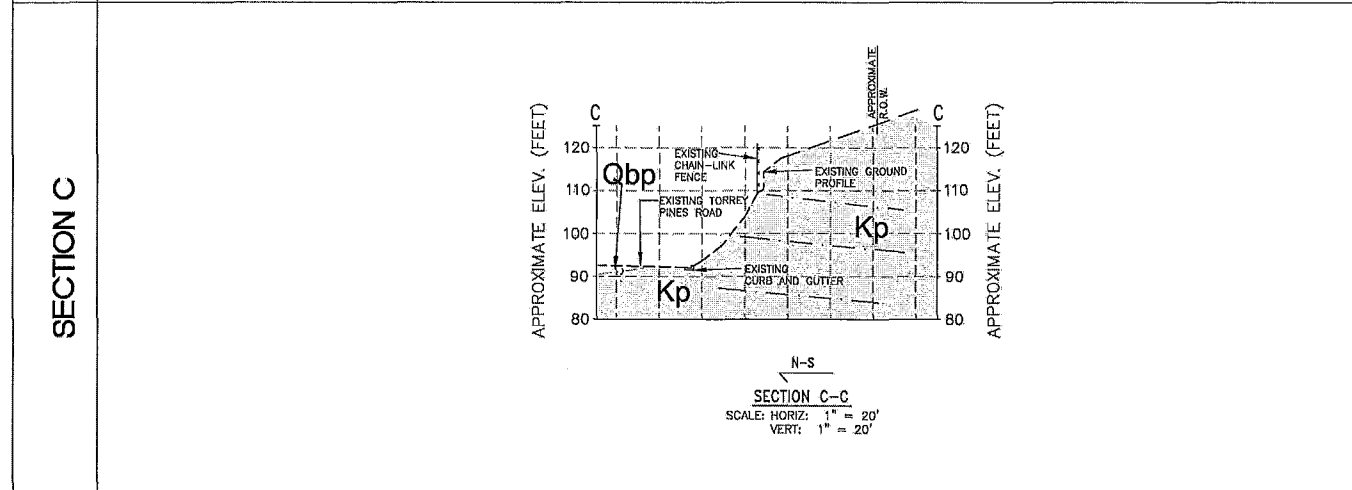
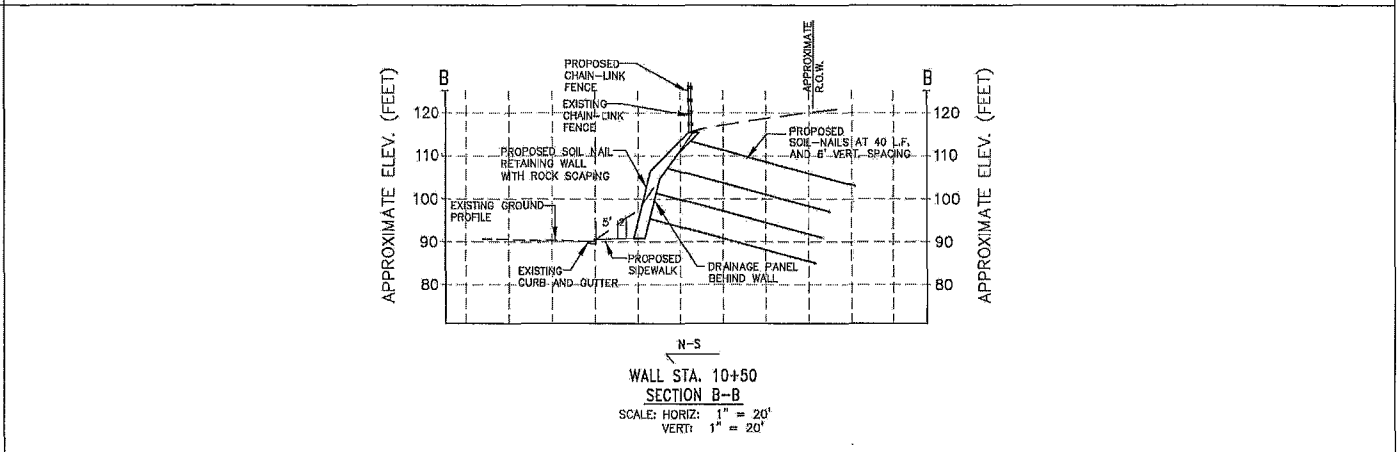
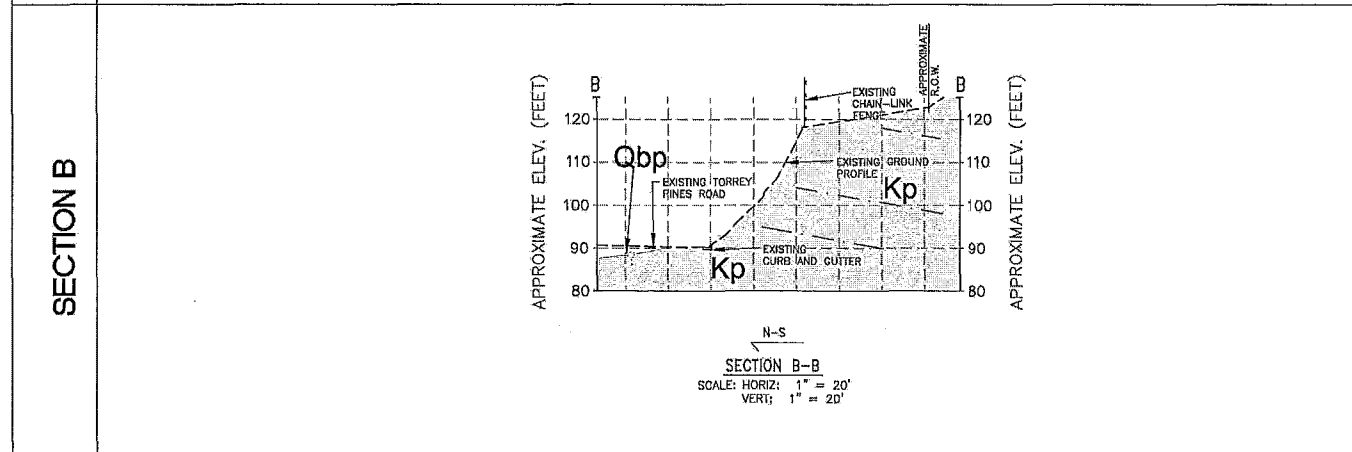
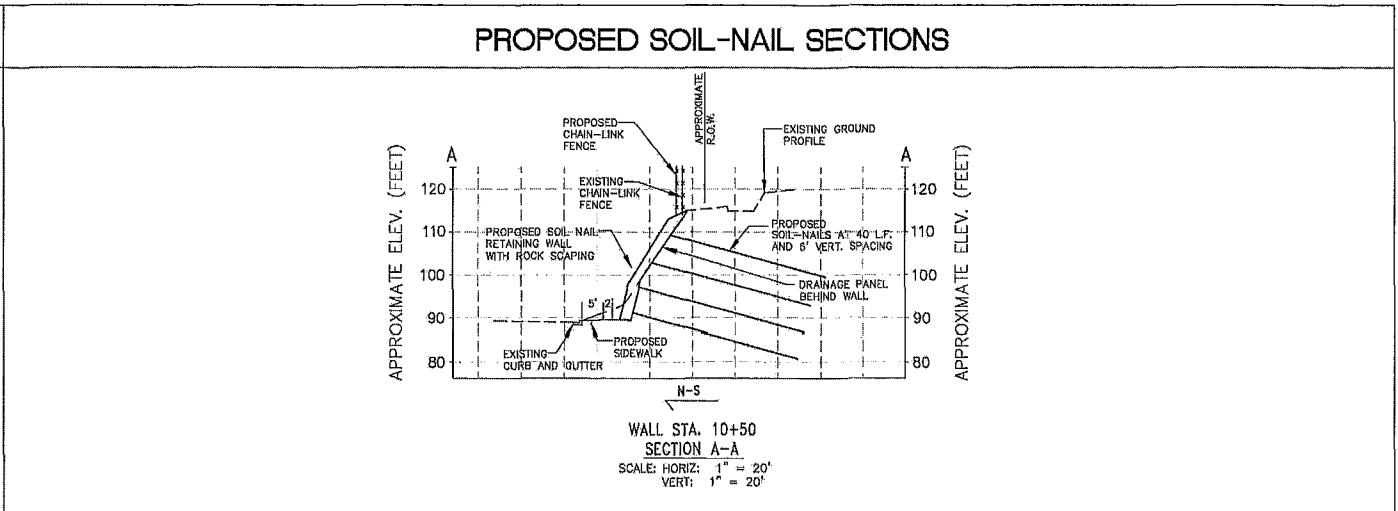
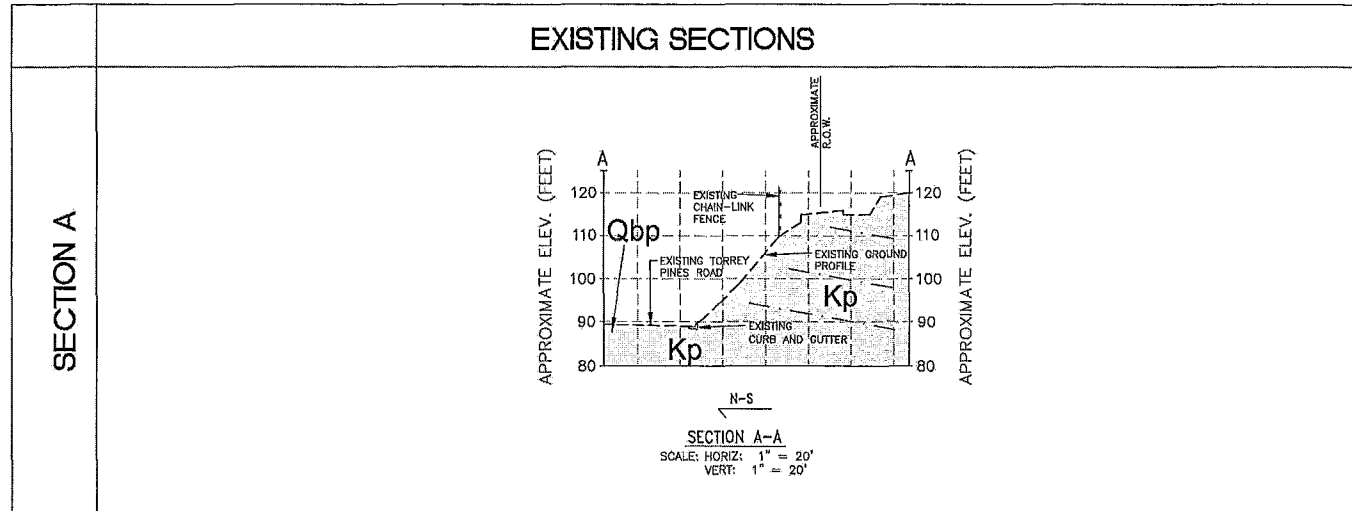

PLATE 1  Leighton	GEOTECHNICAL MAP	
	TORREY PINES ROAD SLOPE RECONSTRUCTION BETWEEN LITTLE STREET AND ROSELAND DRIVE SAN DIEGO, CALIFORNIA	
	Proj: 040596-003	Eng/Geol: WDO/MRS
	Scale: 1"=20'	Date: 05/2011



NOTES

LEGEND

Qbp QUATERNARY BAY POINT FORMATION, DASHED WHERE APPROXIMATE QUERIED WHERE UNCERTAIN

Kp CRETACEOUS POINT LOMA FORMATION, DASHED WHERE APPROXIMATE QUERIED WHERE UNCERTAIN

ESTIMATED EARTHWORK
SOIL-NAIL ALTERNATIVE

CUT: 698 CY
BULKING: 84 CY
EXPORT 782 CY

 Leighton	PLATE 2	
	CROSS-SECTIONS	
	TORREY PINES ROAD SLOPE RECONSTRUCTION BETWEEN LITTLE STREET AND ROSELAND DRIVE SAN DIEGO, CALIFORNIA	
Proj: 040596-003	Eng/Geol: WDO/MRS	
Scale: 1"=20'	Date: 06/2011	

APPENDIX A

References

- Abrahamson, N.A., and Silva, W.J., 1997, Empirical Response Spectral Attenuation Relationships for Shallow Crustal Earthquakes, Seismological Research Letters, 1997, Volume 68, Number 1, Seismological Society of America, Pub, pp. 94-127.
- Bartlett, S.F., and Youd, T.L., 1995, Empirical Prediction of Liquefaction-Induced Lateral Spread, Journal of Geotechnical Engineering, Vol. 121, No. 4, April 1995.
- Blake, 2000a, EQFAULT, Ver. 3.00a.
- California Building Standards Commission (CBSC), 2010, California Building Code, Volumes 1 and 2.
- California Division of Mines and Geology (CDMG), 1996, Probabilistic Seismic Hazard Assessment for the State of California, Open File Report 96-08.
- , 1997, Guidelines for Evaluating and Mitigating Seismic Hazards in California, Special Publication 117, March 13, 1997.
- , 1998, Maps of Known Active Faults Near-Surface Zones in California and Adjacent Portions of Nevada, February 1998.
- Hart, E.W., 1997, Fault-Rupture Hazard Zones in California, Alquist-Priolo Earthquake Fault Zoning Act with Index to Earthquake Fault Zones Maps: Department of Conservation, Division of Mines and Geology, Special Publication 42.
- Kennedy, M.P., 1975, Geology of the San Diego Metropolitan Area, California Section A-Western San Diego Metropolitan Area: California Division of Mines and Geology Bulletin 200, 38p.
- NTIS, 1996, Manual for Design and Construction Monitoring of Soil Nail Walls, November, 1996
- NTIS, 1998, Soil Nail Inspectors Manual, Soil Nail Walls, November, 1998

APPENDIX A (Continued)

- Leighton and Associates, Inc., 2002, 30 Percent Design and Alternatives Evaluation Report, Design of Surface Erosion Control, Torrey Pines Road, Between Little Street and Roseland Drive, La Jolla, San Diego, California, Project No. 040596-001, dated May 21, 2002.
- , 2003, Addendum Report and Geotechnical Response to the City of San Diego, Review of Torrey Pines Road Slope Reconstruction Design (30% and 90% Submittals), Torrey Pines Road, Between Little Street and Roseland Drive, La Jolla, San Diego, California, Project No. 040596-002, dated February 17, 2003.
- Lindvall, S.C., and Rockwell, T.K., 1995, Holocene Activity of the Rose Canyon Fault Zone in San Diego, California: *Journal of Geophysical Research*, V. 100, No. B12, p. 24, 124-24, 132.
- Seed, H.B., and Idriss, I.M., 1982, *Ground Motions and Soil Liquefaction During Earthquakes*, Monogram Series, Earthquake Engineering Research Institute, Berkeley, California.
- Seed, H.B., Idriss, I.M., and Arango, I., 1983, Evaluation of Liquefaction Potential Using Field Performance Data, *Journal of Geotechnical Engineering: ASCE*, Volume 109, March, pp. 458-482.
- Treiman, J.A., 1984, *The Rose Canyon Fault Zone: A Review and Analysis*, California Division of Mines and Geology, Funded by Federal Management Agency Cooperative Agreement EMF-83-K-0148.

Boring Logs

From:

Leighton and Associates, 2002

GEOTECHNICAL BORING LOG KEY

Date _____
 Project KEY TO BORING LOG GRAPHICS
 Drilling Co. _____
 Hole Diameter _____ Drive Weight _____
 Elevation Top of Hole +/- _____ ft. Ref. or Datum _____

Sheet 1 of 1
 Project No. _____
 Type of Rig _____ Drop _____ in.

Elevation (feet)	Depth (feet)	Graphic Log	Notes	Sample No.	Blows Per Foot	Dry Density (pcf)	Moisture Content (%)	Soil Class. (U.S.C.S.)	GEOTECHNICAL DESCRIPTION
									Logged By _____ Sampled By _____
	0							CL	Inorganic clay of low to medium plasticity; gravelly clay; sandy clay; silty clay; lean clay
								CH	Inorganic clay or high plasticity; fat clay
								OL-OH	Organic clay, silt or silty clay-clayey silt mixtures
								ML	Inorganic silt; very fine sand; silty or clayey fine sand; clayey silt with low plasticity
	5							MH	Inorganic silt; diatomaceous fine sandy or silty soils; elastic silt
								CL-ML	Low plasticity clay to silt mixture
								ML-SM	Sandy silt to silty sand mixture
								CL-SC	Sandy clay to clayey sand mixture
								SC-SM	Clayey sand to silty sand mixture
	10							SW	Well graded sand; gravelly sand, little or no fines
								SP	Poorly graded sand; gravelly sand, little or no fines
								SM	Silty sand; poorly graded sand-silt mixture
								SC	Clayey sand; poorly graded sand; clay mixture
								GW	Well graded gravel; gravel-sand mixture, little or no fines
	15							GP	Poorly graded gravel; gravel-sand mixture, little or no fines
								GM	Silty gravel; gravel-sand-silt mixture
								GC	Clayey gravel; gravel-sand-clay mixture
									Sandstone
									Siltstone
									Claystone
	20								Breccia (angular gravel and cobbles or matrix-support conglomerate)
									Conglomerate (rounded gravel and cobble clast-supported)
									Igneous granitic or granitic type rock
									Metavolcanic or metamorphic rock
	25								Artificial or man-made fill
									Asphaltic concrete
									Portland cement concrete
	30								

SPT
SAMPLE

CAL
SAMPLE

GROUND WATER
TABLE AT TIME
OF DRILLING



GEOTECHNICAL BORING LOG B-1

Date 2-17-02

Sheet 1 of 1

Project Torrey Pines Road

Project No. 040596-001

Drilling Co. Condon-Johnson

Type of Rig Ingersoll-Rand

Hole Diameter 6 in. Drive Weight N/A

Drop N/A in.

Elevation Top of Hole +/- 97 ft. Ref. or Datum Mean Sea Level

Elevation (feet)	Depth (feet)	Graphic Log	Notes	Sample No.	Blows Per Foot	Dry Density (pcf)	Moisture Content (%)	Soil Class. (U.S.C.S.)	GEOTECHNICAL DESCRIPTION
									Logged By <u>KRD</u> Sampled By <u>KRD</u>
95	0	/ / / / /						SC/SM ML	TOPSOIL/Qcol @ 0-6" CRETACEOUS POINT LOMA FORMATION (Kp) @ 6": SILTSTONE: Gray to bluish gray, dry, very dense; appears interbedded
	5			Bag-1 CS1	█		11.5		
	10			Bag-2 CS2	█		10.5		
	15			Bag-3 CS3	█		11.4		
80									Total Depth = 15 Feet No ground water encountered at time of drilling Backfilled: 2/17/02
75									
70									
65									
60									
55									
50									
45									
40									
35									
30									

505A(11/77)

LEIGHTON & ASSOCIATES

GEOTECHNICAL BORING LOG B-2

Date 2-17-02

Sheet 1 of 1

Project Torrey Pines Road

Project No. 040596-001

Drilling Co. Condon-Johnson

Type of Rig Ingersoll-Rand

Hole Diameter 6 in. Drive Weight N/A

Drop N/A in.

Elevation Top of Hole +/- 94 ft. Ref. or Datum Mean Sea Level

Elevation (feet)	Depth (feet)	Graphic Log	Notes	Sample No.	Blows Per Foot	Dry Density (pcf)	Moisture Content (%)	Soil Class. (U.S.C.S.)	GEOTECHNICAL DESCRIPTION
									Logged By <u>KRD</u> Sampled By <u>KRD</u>
90	5	[Diagonal Hatching]		Bag-4 CS4	[Black Bar]		10.5	SC/SM SC	TOPSOIL/Ocol @ 0-6" POINT LOMA FORMATION (Kp) @ 6": Clayey SANDSTONE: Light brown, dry, very dense; massive, non-friable
85	10	[Diagonal Hatching]		Bag-5 CS5	[Black Bar]		9.9		
80	15	[Diagonal Hatching]		Bag-6 CS6	[Black Bar]		11.4		
75	20								Total Depth = 17 Feet No ground water encountered at time of drilling Backfilled: 2/17/01
70	25								
65									
60	30								

505A(11/77)

LEIGHTON & ASSOCIATES

Appendix C

Test Results of Preliminary Soil-Nailing

RECORD OF OBSERVATIONS DURING SOIL TIEBACK PROOF TESTING

Project: Torrey Pines Road Retaining Wall	L&A Project No.: 040596-001	Date: 2/27/02	
Location: Between Little Street and Roseland Drive	Permit No.: N/A	Tie-back Test Location	
General Contractor: Condon-Johnson	Plan File No.: N/A	Wall	Level
Shoring Contractor:	Inspector: KRD	T.P. ROAD	N/A
		2	PASTERLY

Design Test Load	Kips	psi
DL =	20	1589

Time Increments (minutes)													
0	1	2	3	4	5	6	10	15	20	25	30	45	60

Proof Testing Load Schedule	Kips	psi
Alignment 0.125*DL =	2.5	199
0.25*DL =	5	397
0.50*DL =	10	795
0.75*DL =	15	1192
1.00*DL =	20	1589
1.20*DL =	24	1907
1.33*DL =	26.6	2113

Movement Measurements													
(measure to the nearest 0.001 inch or 0.0254 millimeter until stable reading obtained)													
0.00	0.00	0.00											
0.200	0.200	0.200											
0.936	0.936	0.936											
1.572	1.572	1.572											
2.650	2.650	2.650											
4.203	4.204	4.204											
5.071	5.071	5.071	5.071	5.071	5.071	5.071	5.071	5.071					

* Creep test must continue for at least 10 minutes.
 If movement between 1 and 10 minutes exceeds 1mm (0.0394"), test shall continue to 60 minutes

Comments: ⊕ MEASUREMENTS HAVE BEEN ADJUSTED TO ACCOUNT FOR PLATE MOVEMENT INTO SLOPE FACE.



RECORD OF OBSERVATIONS DURING SOIL TIEBACK PROOF TESTING

Project: Torrey Pines Road Retaining Wall	L&A Project No.: 040596-001	Date: 2/27/02		
Location: Between Little Street and Roseland Drive	Permit No.: N/A	Tie-back Test Location		
General Contractor: Condon-Johnson	Plan File No.: N/A	Wall	Level	Tie-back #
Shoring Contractor:	Inspector: KRP	T.P. ROAD	NA	ONE WESTBLY

Design Test Load	Kips	psi
DL =	20	1589

Time Increments (minutes)													
0	1	2	3	4	5	6	10	15	20	25	30	45	60

Proof Testing Load Schedule	Kips	psi
Alignment 0.125*DL =	2.5	199
0.25*DL =	5	397
0.50*DL =	10	795
0.75*DL =	15	1192
1.00*DL =	20	1589
1.20*DL =	24	1907
1.33*DL =	26.6	2113

Movement Measurements													
(measure to the nearest 0.001 inch or 0.0254 millimeter until stable reading obtained)													
0.00	0.00	0.00	0.00										
0.505	0.506	0.506											
1.304	1.304	1.304											
1.696	1.696	1.696											
2.137	2.137	2.137											
3.010	3.011	3.012	3.012										
3.142	3.142	3.142	3.142	3.142	3.142	3.142	3.142						

* Creep test must continue for at least 10 minutes.
 If movement between 1 and 10 minutes exceeds 1mm (0.0394"), test shall continue to 60 minutes

Comments: ⊕ MEASUREMENTS HAVE BEEN ADJUSTED TO ACCOUNT FOR PLATE MOVEMENT INTO SLOPE FACE.



PREFORMANCE TEST

Project No.: 040596-001

(K20)

Nail No.: TWO (EASTERLY)

Date: 2/27/02

Time: 12:45 P M

Design Load: 20 kips

Alignment Load 2 kips

Ram: 43394

Guage: T60031

INCREMENT	LOAD	GAUGE	DEFLECTION	COMMENTS
0.1 (AL)	2 k	159	0.000	
0.25	5 k	397	0.053	
0.1 (AL)	2 k	159	0.070	
0.25	5 k	397	0.081	
0.5	10 k	795	0.337	
0.1 (AL)	2 k	159	0.007	
0.25	5 k	397	0.011	
0.5	10 k	795	0.357	
0.75	15 k	1192	0.648	
0.1 (AL)	2 k	159	0.150	
0.25	5 k	397	0.185	
0.5	10 k	795	0.455	
0.75	15 k	1192	0.649	
1	20 k	1589	0.878	
0.1 (AL)	2 k	159	0.137	
0.25	5 k	397	0.284	
0.5	10 k	795	0.474	
0.75	15 k	1192	0.668	
1	20 k	1589	0.888	
1.2	24 k	1907	1.011	
0.1 (AL)	2 k	159	0.190	
0.25	5 k	397	0.261	
0.5	10 k	795	0.639	
0.75	15 k	1192	0.822	
1	20 k	1589	0.972	
1.2	24 k	1907	1.088	
1.3	27 k	2113	2.118	
1.3 (1 min)	27 k	2113	2.118	
1.3 (2 min)	27 k	2113	2.118	
1.3 (3 min)	27 k	2113	2.118	
1.3 (4 min)	27 k	2113	2.118	
1.3 (5 min)	27 k	2113	2.118	
1.3 (6 min)	27 k	2113	2.118	
1.3 (10 min)	27 k	2113	2.118	

MEASUREMENTS HAVE BEEN ADJUSTED TO ACCOUNT FOR PLATE MOVEMENT INTO SLOPE FACE.

APPENDIX D

Laboratory Testing Procedures and Test Results

Atterberg Limits: The Atterberg Limits were determined in accordance with ASTM Test Method D423 for engineering classification of the fine-grained materials and presented in the table below:

Sample Location	Liquid Limit (%)	Plastic Limit (%)	Plastic Index (%)	USCS Soil Classification
B-1, 5'-6'	43	24	19	CL

Direct Shear Tests: Direct shear tests were performed during soil nail installation on selected remolded samples which were soaked for a minimum of 24 hours under a surcharge equal to the applied normal force during testing. After transfer of the sample to the shear box and reloading of the sample, the pore pressures set up in the sample (due to the transfer) were allowed to dissipate for a period of approximately 1 hour prior to application of shearing force. The samples were tested under various normal loads utilizing a motor-driven, strain-controlled, direct-shear testing apparatus at a strain rate of less than 0.001 to 0.5 inches per minute (depending upon the soil type). After a "peak" value of shear strength was observed or after a shear strain of 0.2 inches if no peak was observed, the motor was stopped and the sample was allowed to "relax" for approximately 15 minutes. The stress drop during the relaxation period was recorded. It is anticipated that, in the sample tested, the 15 minutes relaxing of the samples is sufficient to allow dissipation of pore pressures that may have set up in the samples due to shearing. The drained peak strength was estimated by deducting the shear force reduction during the relaxation period from the peak shear values. The shear values at the end of shearing are "ultimate" values. The peak and ultimate strength values are presented on the attached test data sheets.

Classification or Grain Size Tests: Typical materials were subjected to mechanical grain-size analysis by sieving from U.S. Standard brass screens (ASTM Test Method D422). Hydrometer analyses were performed where appreciable quantities of fines were encountered. The data was evaluated in determining the classification of the materials. The grain-size distribution curves are presented in the test data and the Unified Soil Classification (USCS) is presented in both the test data and the boring and/or trench logs.

Moisture Determination Tests: Moisture content determinations were performed on relatively undisturbed samples obtained from the test borings. The results of these tests are presented in the boring logs. Where applicable, only moisture content was determined from "undisturbed" or disturbed samples.

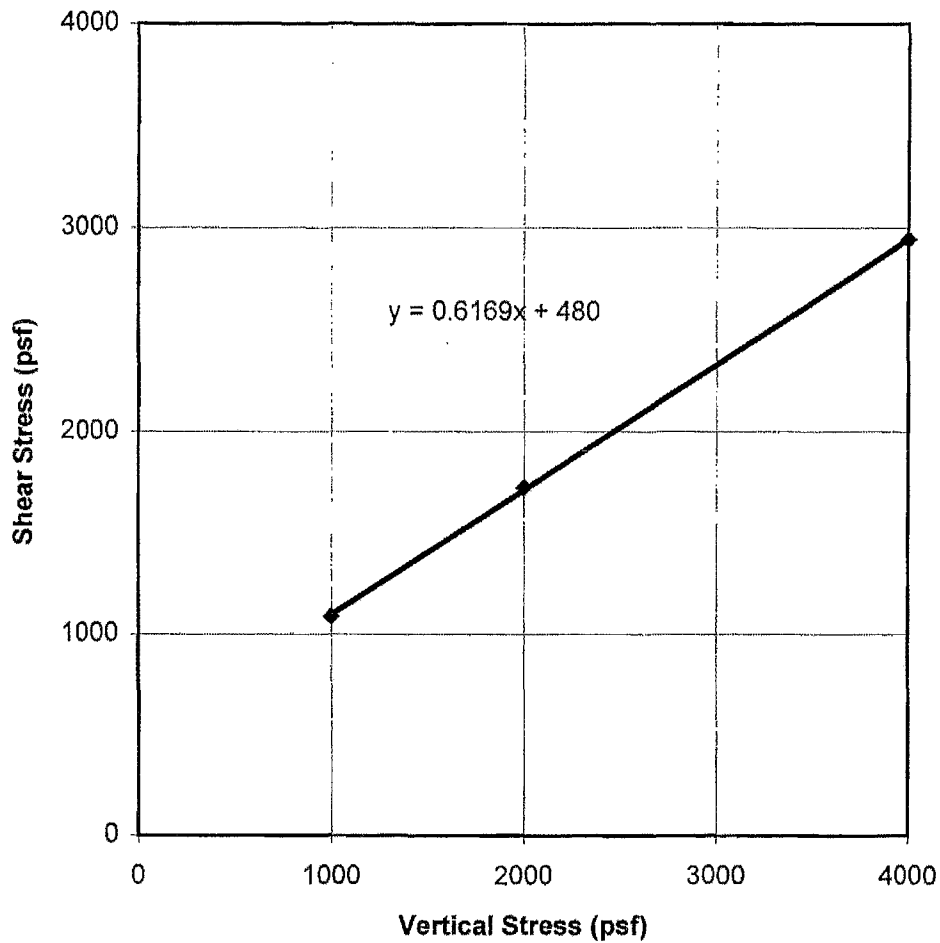

Boring Location	<u>B-1</u>
Sample Depth (feet)	<u>10-11</u>
Average Peak Strength Values	
Friction Angle, ϕ_{peak} (deg)	<u>32</u>
Cohesion, c_{peak} (psf)	<u>500</u>

DIRECT SHEAR SUMMARY

Project No.	<u>040596-001</u>
Project Name	<u>City S.D./T.P. Road</u>
Figure No.	<u>D-2</u>



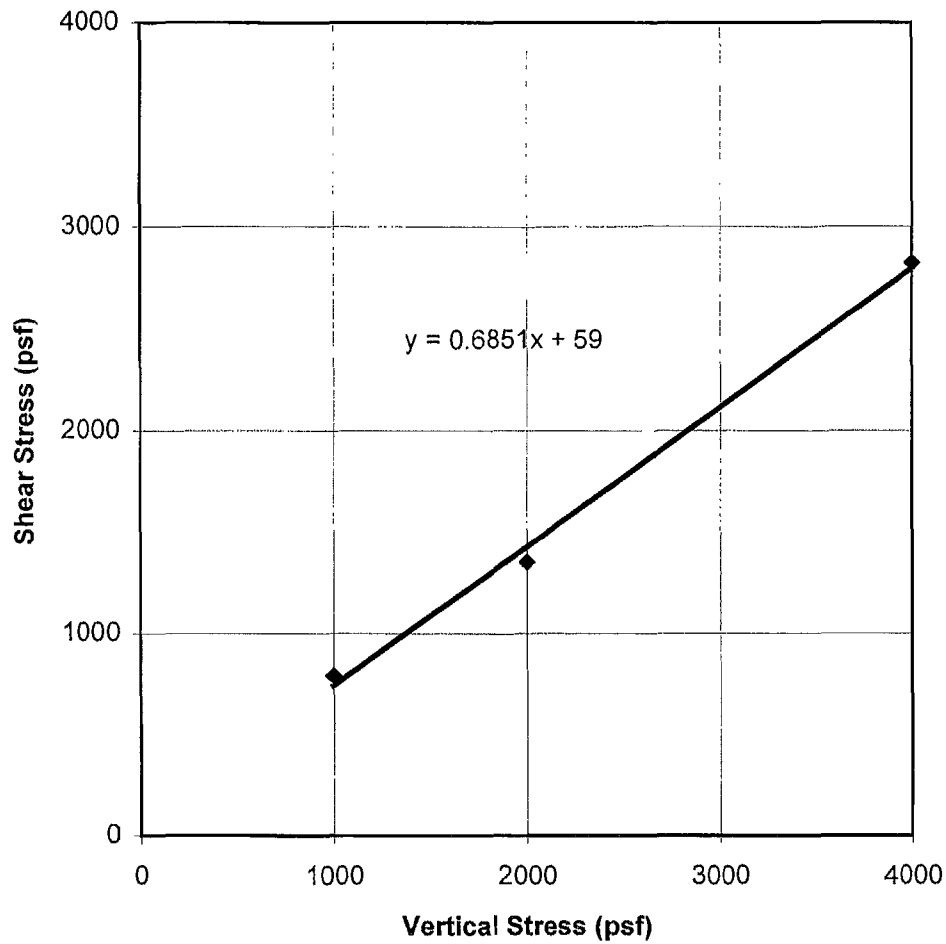

Boring Location B-1

Sample Depth (feet) 15.0'

Average Peak Strength Values

Friction Angle, ϕ_{peak} (deg) 34

Cohesion, c_{peak} (psf) 60

DIRECT SHEAR SUMMARY

Project No. 040596-001
 Project Name City S.D./T.P. Road
 Figure No. D-2



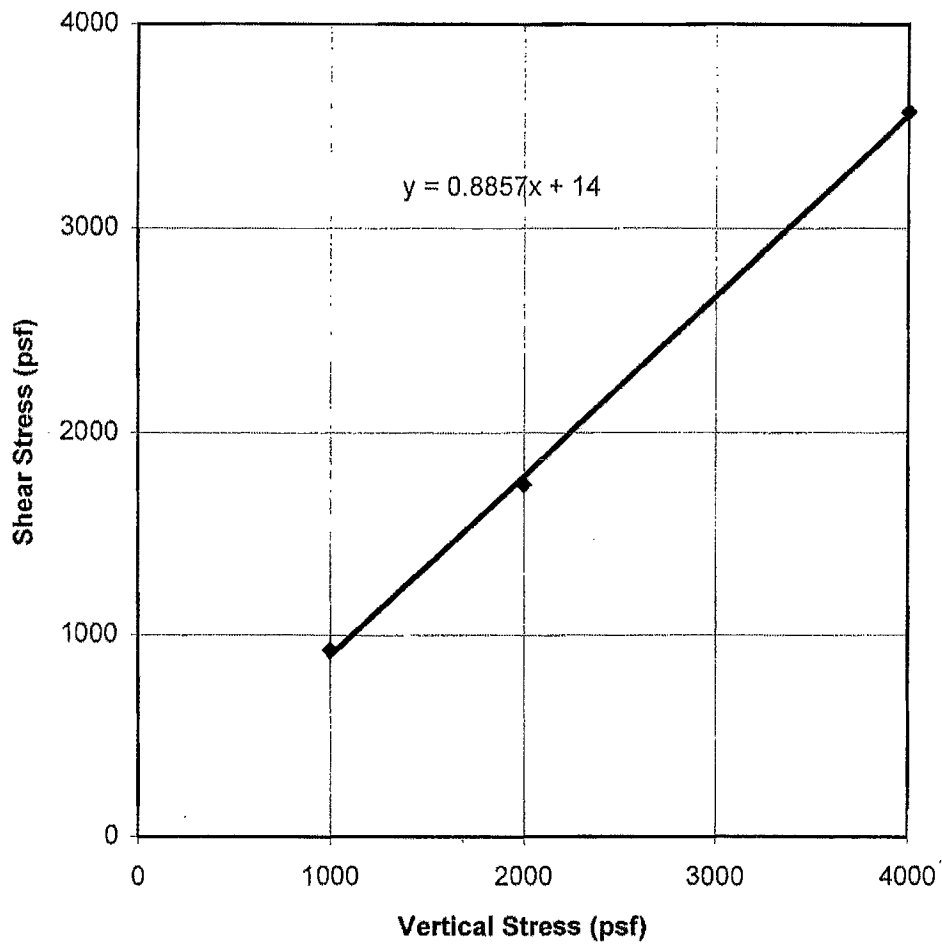

Boring Location B-2

Sample Depth (feet) 5-6'

Average Peak Strength Values

Friction Angle, ϕ_{peak} (deg) 41

Cohesion, c_{peak} (psf) 20

DIRECT SHEAR SUMMARY

Project No. 040596-001
 Project Name City S.D./T.P. Road
 Figure No. D-3





Moisture Content
ASTM D 2216

Project Name: TORREY PINES ROAD
Project No. : 040596-001

Tested By: PRC
Date: 2/19/02

Container Number:	C	L	G	D	O	A
Sample Type:	CHUNK	CHUNK	CHUNK	CHUNK	CHUNK	CHUNK
Boring No.:	B-1	B-1	B-1	B-2	B-2	B-2
Sample No.:	1	2	3	4	5	6
Depth: (ft.)	4.5	10.0	15.0	5.0-6.0	10.0	15.0
Soil Type:	(CL)s	(CL)s	(CL)s	s(CL)	SM	SC
Moisture Content (%)	11.5	10.5	11.4	10.5	9.9	11.4
Wt. Wet Soil+Container (g)	368.5	405.9	326.3	260.0	409.1	273.0
Wt. Dry Soil+Container (g)	336.0	372.5	298.3	240.7	377.1	250.6
Weight Container (g)	54.5	55.0	53.7	56.8	54.7	54.6

Container Number:						
Sample Type:						
Boring No.:						
Sample No.:						
Depth: (m)						
Soil Type:						
Moisture Content (%)						
Wt. Wet Soil+Container (g)						
Wt. Dry Soil+Container (g)						
Weight Container (g)						

Container Number:						
Sample Type:						
Boring No.:						
Sample No.:						
Depth: (ft.)						
Soil Type:						
Moisture Content (%)						
Wt. Wet Soil+Container (g)						
Wt. Dry Soil+Container (g)						
Weight Container (g)						

Project Name: TORREY PINES ROAD Tested By: PRC Date: 2/19/02
 Project No.: 040596-001 Input By: PRC Date: _____
 Boring No.: B-1 Checked By: _____ Date: _____
 Sample No.: 2 Depth (ft.): 10.0
 Sample Description: s(CL), OLIVE BROWN SANDY LEAN CLAY

TEST NO.	PLASTIC LIMIT		LIQUID LIMIT		
	1	2	1	2	3
Number of Blows [N]			37	23	17
Container No.	1	2	3	4	5
Wet Wt. of Soil + Cont. (g)	9.41	10.90	11.03	12.38	11.01
Dry Wt. of Soil + Cont. (g)	7.82	9.02	8.22	9.02	7.96
Wt. of Container (g)	1.30	1.29	1.31	1.32	1.32
Moisture Content (%) [Wn]	24.4	24.3	40.7	43.6	45.9

Liquid Limit
 Plastic Limit
 Plasticity Index
 USCS Classification

43
24
19
CL
17

PI at "A" - Line = $0.73(LL-20)$ =
 One-Point Liquid Limit Calculation
 $LL = Wn(N/25)^{0.121}$

PROCEDURES USED

Wet Preparation

Dry Preparation

Method A
 Multipoint LL

Method B
 One-point LL

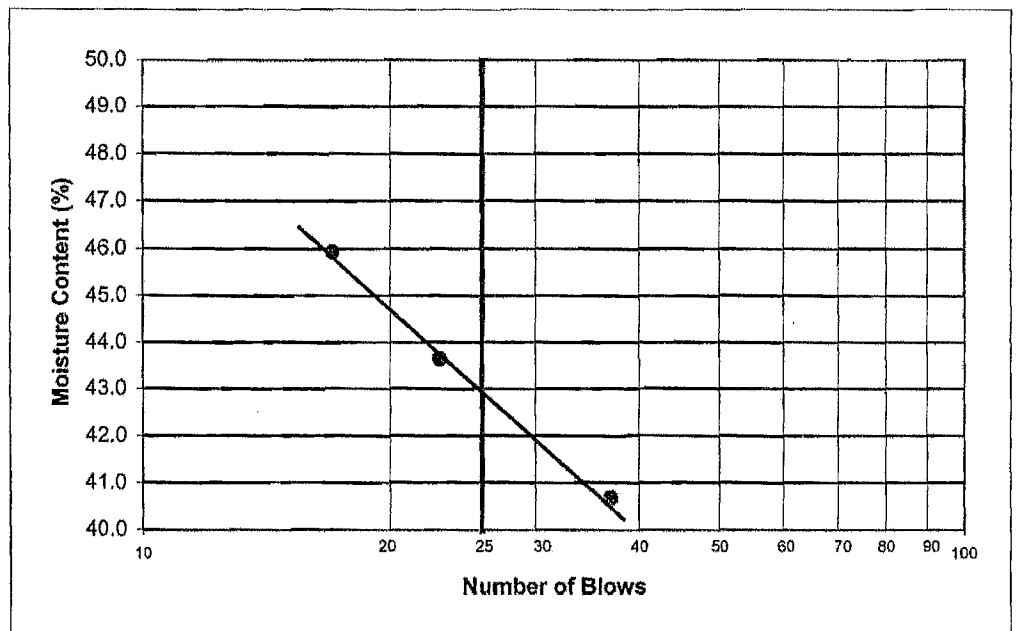
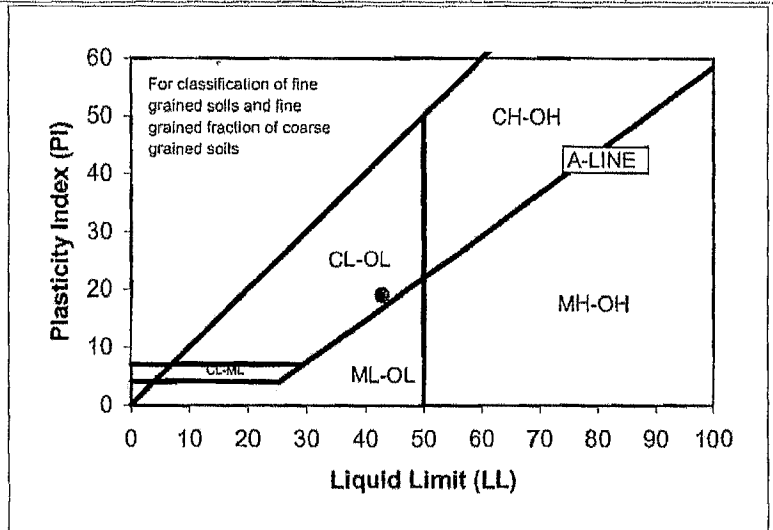

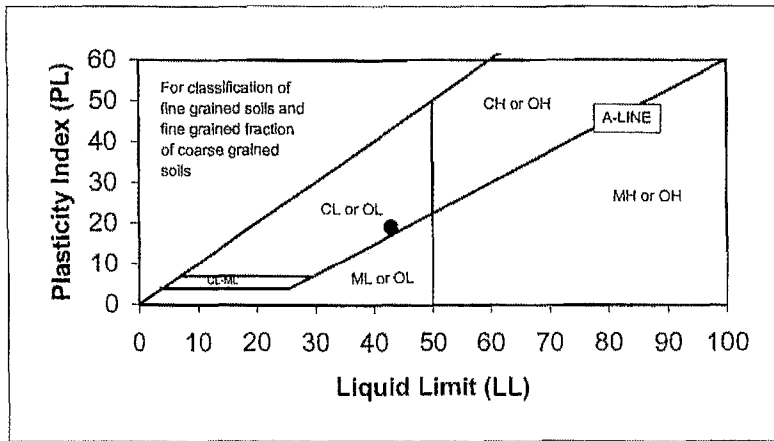

GRAVEL		SAND			FINES	
COARSE	FINE	CRS	MEDIUM	FINE	SILT	CLAY

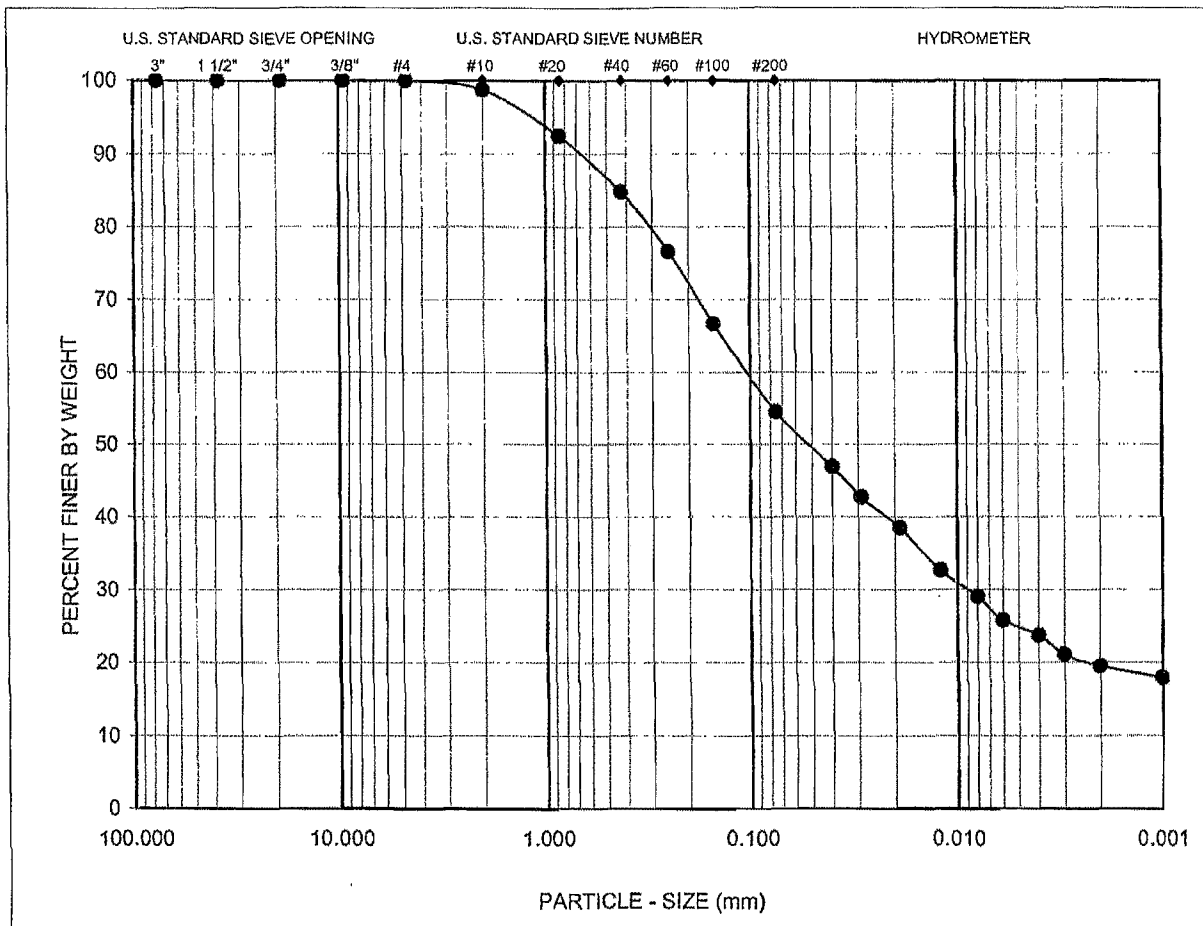

Boring Number	Sample Number	Depth (ft.)	Soil Type	GR (%)	SA (%)	FI (%)	LL	PL	PI
B-2	5	10.0	s(CL)	0	45	55	43	24	19

Sample Description:
s(CL), OLIVE BROWN SANDY LEAN CLAY

Project Name: TORREY PINES ROAD

Project No.: 040596-001



Rev. 02-02

TPR.OUT

```
*****  
*  
*   E Q F A U L T   *  
*  
*   Version 3.00   *  
*  
*****
```

DETERMINISTIC ESTIMATION OF
PEAK ACCELERATION FROM DIGITIZED FAULTS

JOB NUMBER: 040596-003

DATE: 05-16-2011

JOB NAME: TPR

CALCULATION NAME: Test Run Analysis

FAULT-DATA-FILE NAME: C:\Program Files\EQFAULT1\CGSFLTE.DAT

SITE COORDINATES:

SITE LATITUDE: 32.8500

SITE LONGITUDE: 117.2510

SEARCH RADIUS: 100 mi

ATTENUATION RELATION: 2) Boore et al. (1997) Horiz. - NEHRP C (520)

UNCERTAINTY (M=Median, S=Sigma): M Number of Sigmas: 0.0

DISTANCE MEASURE: cd_2drp

SCOND: 0

Basement Depth: 5.00 km Campbell SSR: Campbell SHR:

COMPUTE PEAK HORIZONTAL ACCELERATION

FAULT-DATA FILE USED: C:\Program Files\EQFAULT1\CGSFLTE.DAT

MINIMUM DEPTH VALUE (km): 0.0

EQFAULT SUMMARY

DETERMINISTIC SITE PARAMETERS

Page 1

ABBREVIATED FAULT NAME	APPROXIMATE DISTANCE mi (km)	ESTIMATED MAX. EARTHQUAKE EVENT		
		MAXIMUM EARTHQUAKE MAG. (Mw)	PEAK SITE ACCEL. g	EST. SITE INTENSITY MOD. MERC.
ROSE CANYON	0.3(0.5)	7.2	0.520	X
CORONADO BANK	12.8(20.6)	7.6	0.227	IX
NEWPORT-INGLEWOOD (Offshore)	23.5(37.9)	7.1	0.110	VII
ELSINORE (JULIAN)	37.4(60.2)	7.1	0.077	VII
ELSINORE (TEMECULA)	39.0(62.7)	6.8	0.064	VI
EARTHQUAKE VALLEY	45.1(72.6)	6.5	0.049	VI
PALOS VERDES	50.0(80.4)	7.3	0.069	VI
ELSINORE (COYOTE MOUNTAIN)	52.2(84.0)	6.8	0.051	VI
SAN JOAQUIN HILLS	54.7(88.0)	6.6	0.054	VI
ELSINORE (GLEN IVY)	55.1(88.6)	6.8	0.049	VI
SAN JACINTO-ANZA	59.8(96.3)	7.2	0.057	VI
SAN JACINTO-COYOTE CREEK	60.1(96.8)	6.6	0.041	V
SAN JACINTO-SAN JACINTO VALLEY	64.5(103.8)	6.9	0.046	VI
NEWPORT-INGLEWOOD (L.A.Basin)	65.2(105.0)	7.1	0.050	VI
SAN JACINTO - BORREGO	65.9(106.1)	6.6	0.038	V
CHINO-CENTRAL AVE. (Elsinore)	68.6(110.4)	6.7	0.048	VI
WHITTIER	72.9(117.3)	6.8	0.039	V
SUPERSTITION MTN. (San Jacinto)	77.8(125.2)	6.6	0.034	V
LAGUNA SALADA	79.9(128.6)	7.0	0.041	V
SAN JACINTO-SAN BERNARDINO	80.7(129.8)	6.7	0.035	V
ELMORE RANCH	82.0(132.0)	6.6	0.032	V
PUENTE HILLS BLIND THRUST	82.6(132.9)	7.1	0.051	VI
SUPERSTITION HILLS (San Jacinto)	82.8(133.2)	6.6	0.032	V
SAN ANDREAS - SB-Coach. M-1b-2	83.3(134.1)	7.7	0.057	VI
SAN ANDREAS - SB-Coach. M-2b	83.3(134.1)	7.7	0.057	VI
SAN ANDREAS - whole M-1a	83.3(134.1)	8.0	0.067	VI
SAN ANDREAS - San Bernardino M-1	83.3(134.1)	7.5	0.051	VI
SAN ANDREAS - Coachella M-1c-5	86.6(139.4)	7.2	0.043	VI
PINTO MOUNTAIN	88.8(142.9)	7.2	0.042	VI
SAN JOSE	89.7(144.4)	6.4	0.033	V
BURNT MTN.	90.1(145.0)	6.5	0.029	V
CUCAMONGA	92.0(148.0)	6.9	0.042	VI
SIERRA MADRE	92.4(148.7)	7.2	0.049	VI
EUREKA PEAK	93.1(149.9)	6.4	0.026	V
NORTH FRONTAL FAULT ZONE (West)	95.1(153.1)	7.2	0.048	VI
BRAWLEY SEISMIC ZONE	96.0(154.5)	6.4	0.026	V
UPPER ELYSIAN PARK BLIND THRUST	97.6(157.0)	6.4	0.031	V
IMPERIAL	97.9(157.5)	7.0	0.035	V
NORTH FRONTAL FAULT ZONE (East)	98.1(157.8)	6.7	0.036	V
CLEGHORN	98.4(158.4)	6.5	0.027	V

Page 2

 DETERMINISTIC SITE PARAMETERS

Page 2

ABBREVIATED FAULT NAME	APPROXIMATE DISTANCE mi (km)	ESTIMATED MAX. EARTHQUAKE EVENT		
		MAXIMUM EARTHQUAKE MAG. (Mw)	PEAK SITE ACCEL. g	EST. SITE INTENSITY MOD. MERC.

-END OF SEARCH- 40 FAULTS FOUND WITHIN THE SPECIFIED SEARCH RADIUS.

THE ROSE CANYON FAULT IS CLOSEST TO THE SITE.
 IT IS ABOUT 0.3 MILES (0.5 km) AWAY.

LARGEST MAXIMUM-EARTHQUAKE SITE ACCELERATION: 0.5202 g

Section A-A

040596-001 TORREY PINES ROAD SECTION A-A' existing topo

C:\KEN\SLOPES~1\040596~1\REVISE~1\A-A\AA_RUN3.PL2 Run By: Username 4/2/02 10:39AM

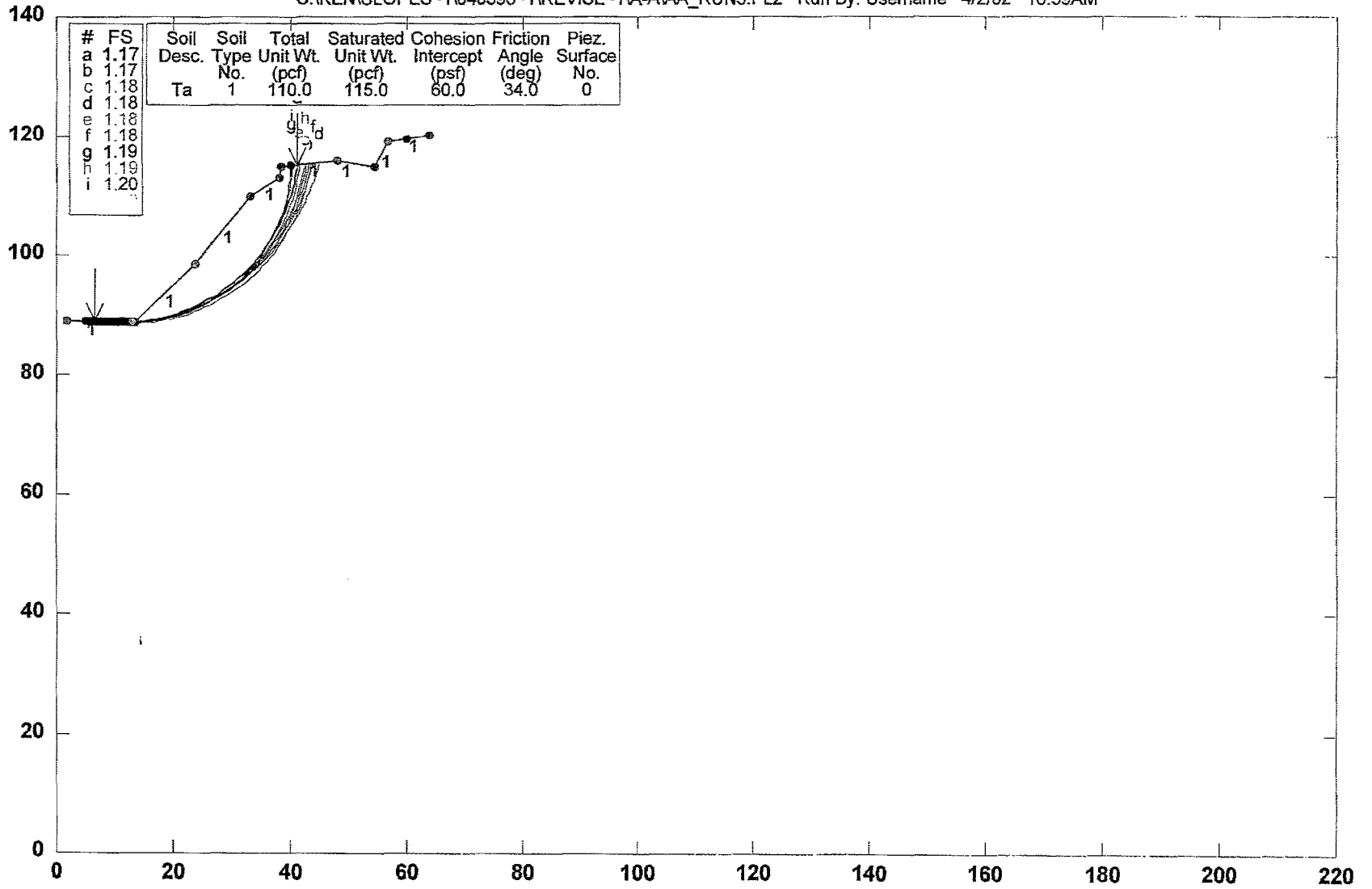

GSTABL7 FSmin=1.17

Safety Factors Are Calculated By The Modified Bishop Method

STED

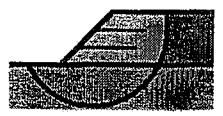

040596-001 TORREY PINES ROAD SECTION A-A'/temp cut for soil nails

C:\KENSLOPES~1\040596~1\REVISE~1\A-A\AA_TEMP1.PL2 Run By: Username 4/2/02 10:41AM

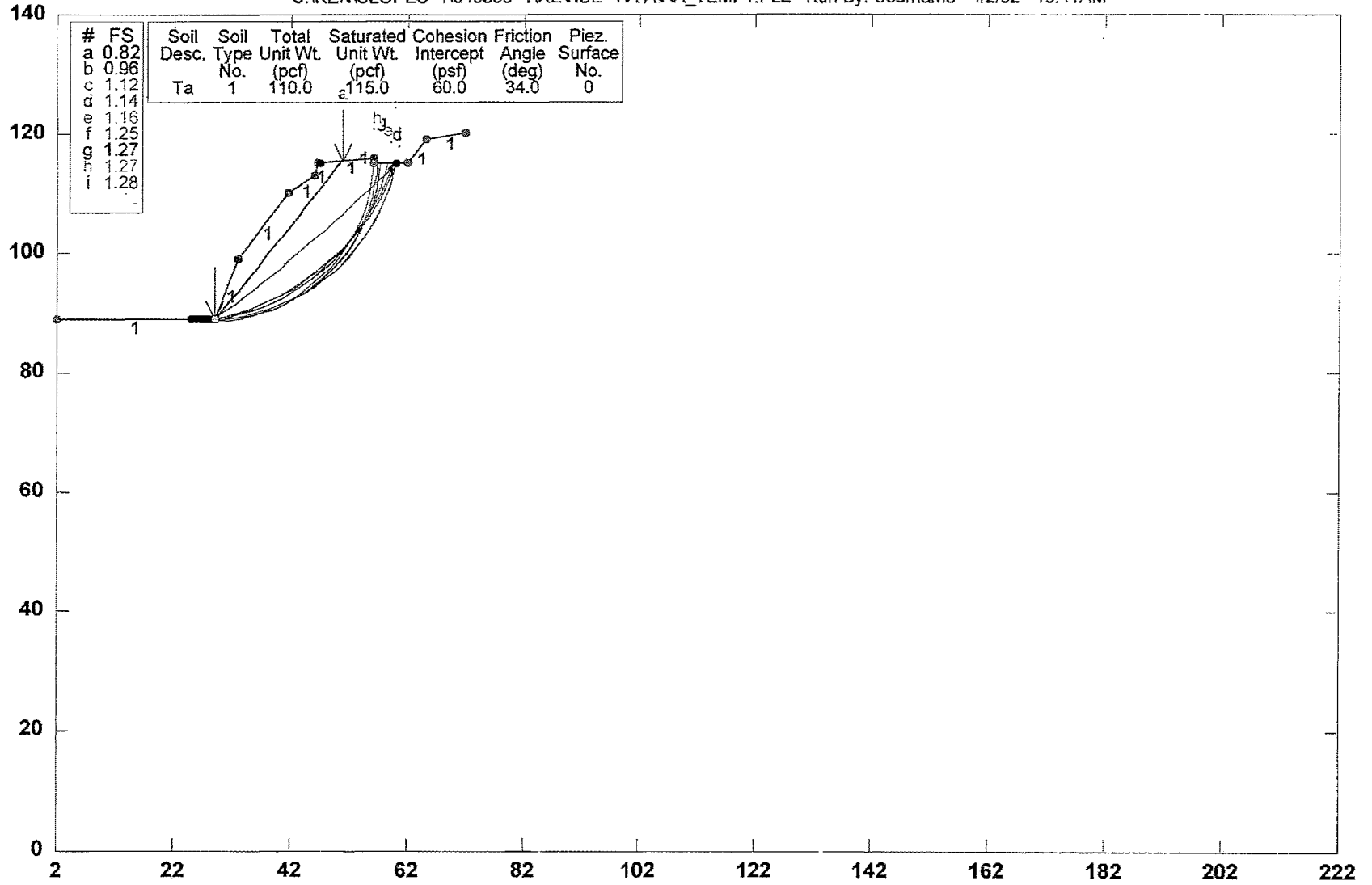

GSTABL7 v.2 FSmin=0.82

Safety Factors Are Calculated By The Modified Bishop Method

STED



040596-001 TORREY PINES ROAD SECTION A-A' soil nail

C:\KENSLOPES~1\040596~1\REVISE~1\A-A\AA_PRO1.PL2 Run By: Username 4/2/02 10:43AM

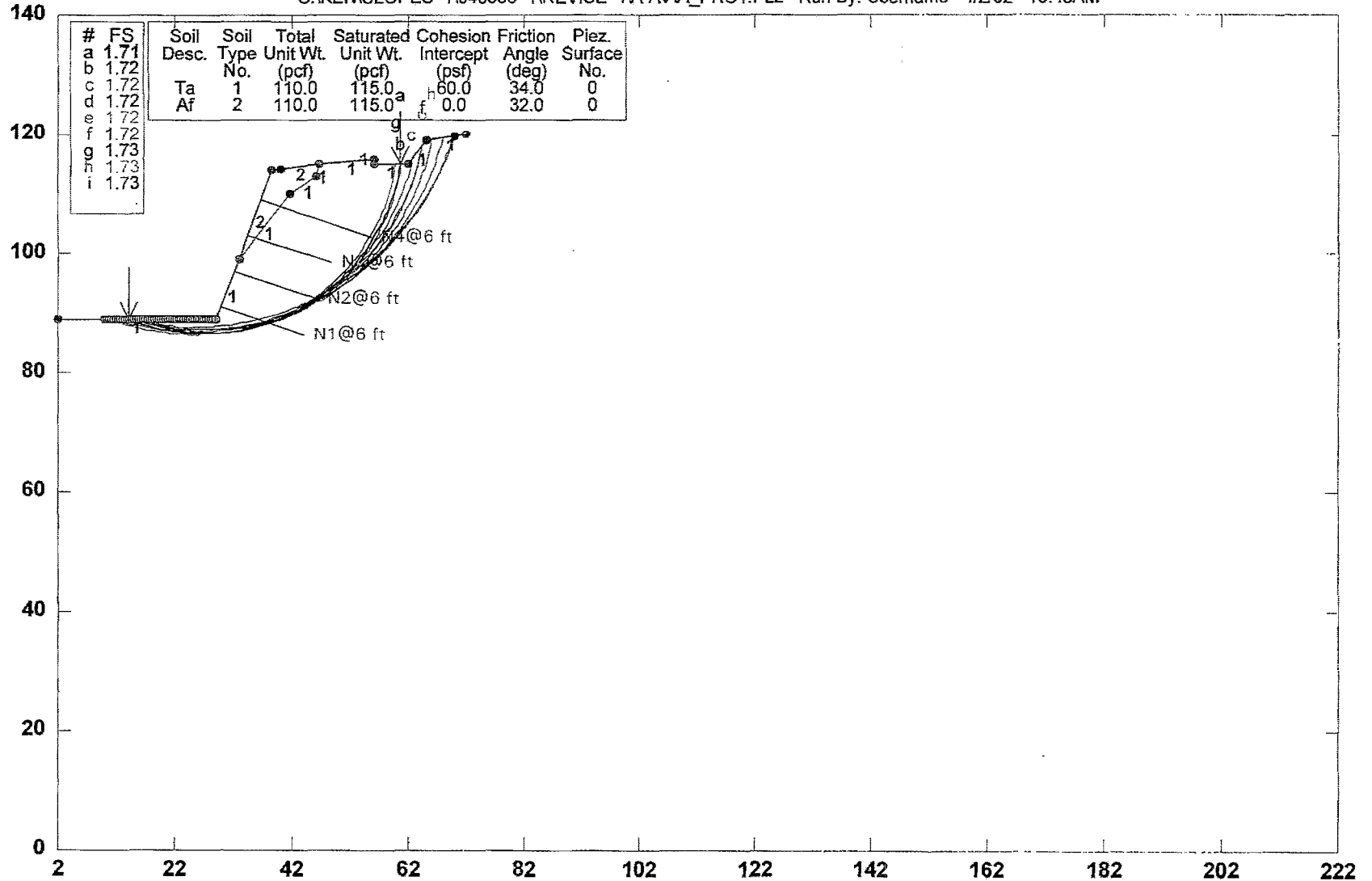

GSTABL7 v.2 FSmin=1.71

Safety Factors Are Calculated By The Modified Bishop Method

STED



040596-001 TORREY PINES ROAD SECTION A-A' soil nail w/seismic

C:\KENSLOPES~1\040596~1\REVISE~1\A-A\AA_PRO3.PL2 Run By: Username 4/2/02 10:35AM

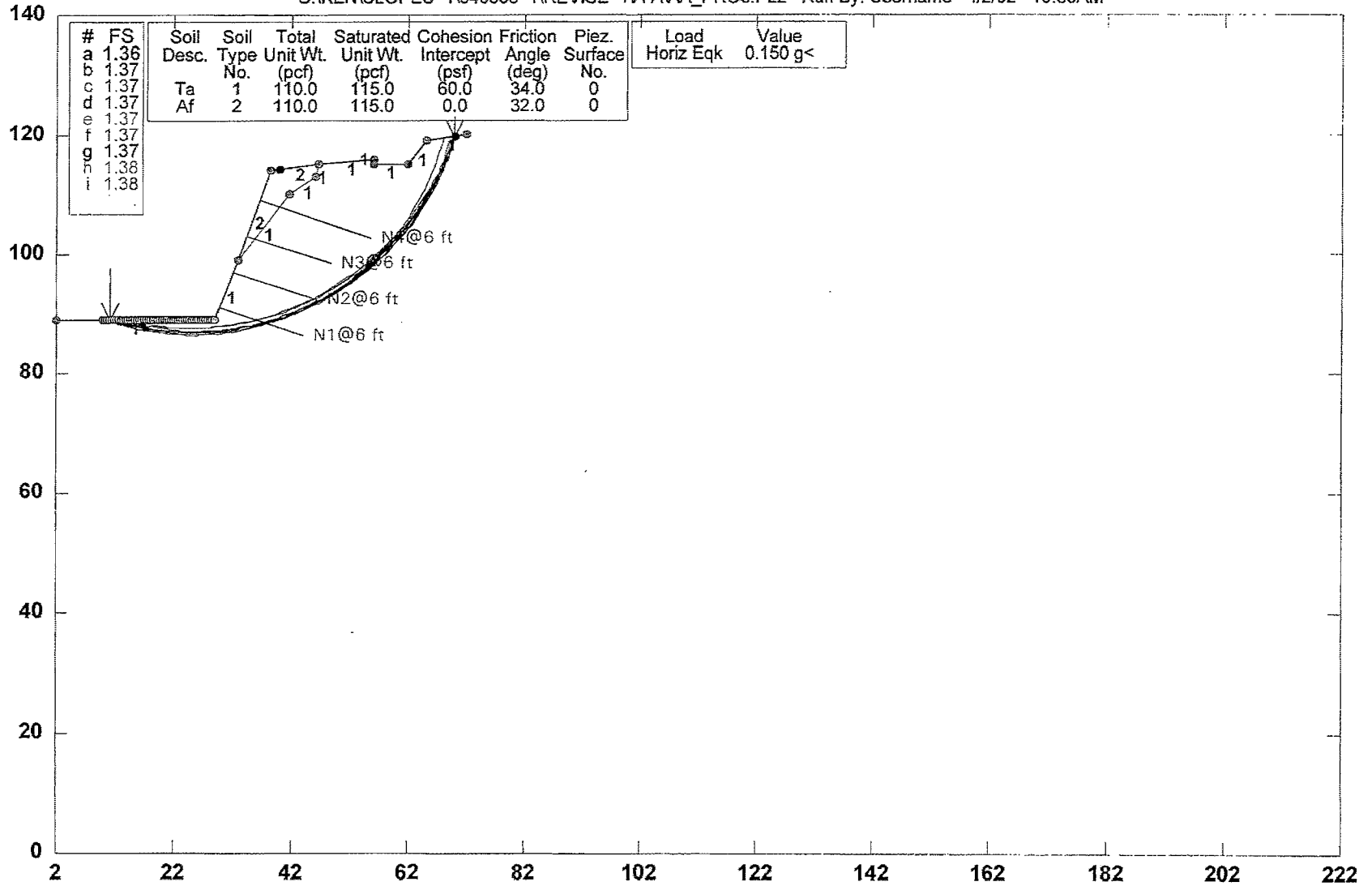

GSTABL7 v.2 FSmin=1.36

Safety Factors Are Calculated By The Modified Bishop Method

STED



040596-001 TORREY PINES ROAD SECTION A-A'/ soil nail w/seismic

C:\KEN\SLOPES-1\040596-1\REVISE-1\A-A\AA_PRO3.PL2 Run By: Username 4/2/02 10:34AM

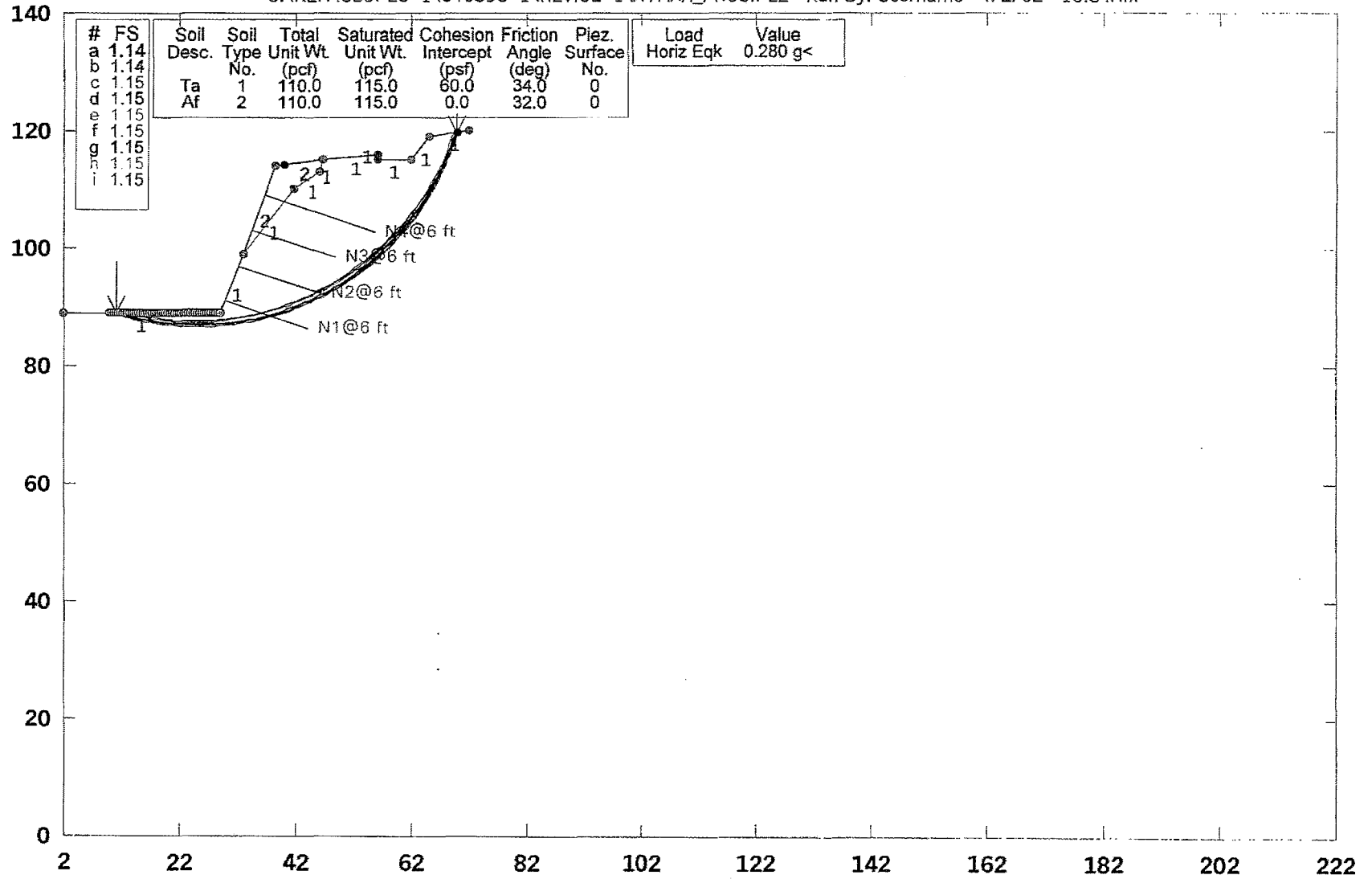

GSTABL7 v.2 FSmin=1.14
Safety Factors Are Calculated By The Modified Bishop Method

STED



040596-001 TORREY PINES ROAD SECTION A-A'/temp for geogrid

C:\KEN\SLOPES~1\040596~1\REVISE~1\A-A\AA_TEMP2.PL2 Run By: Username 4/5/02 12:25PM

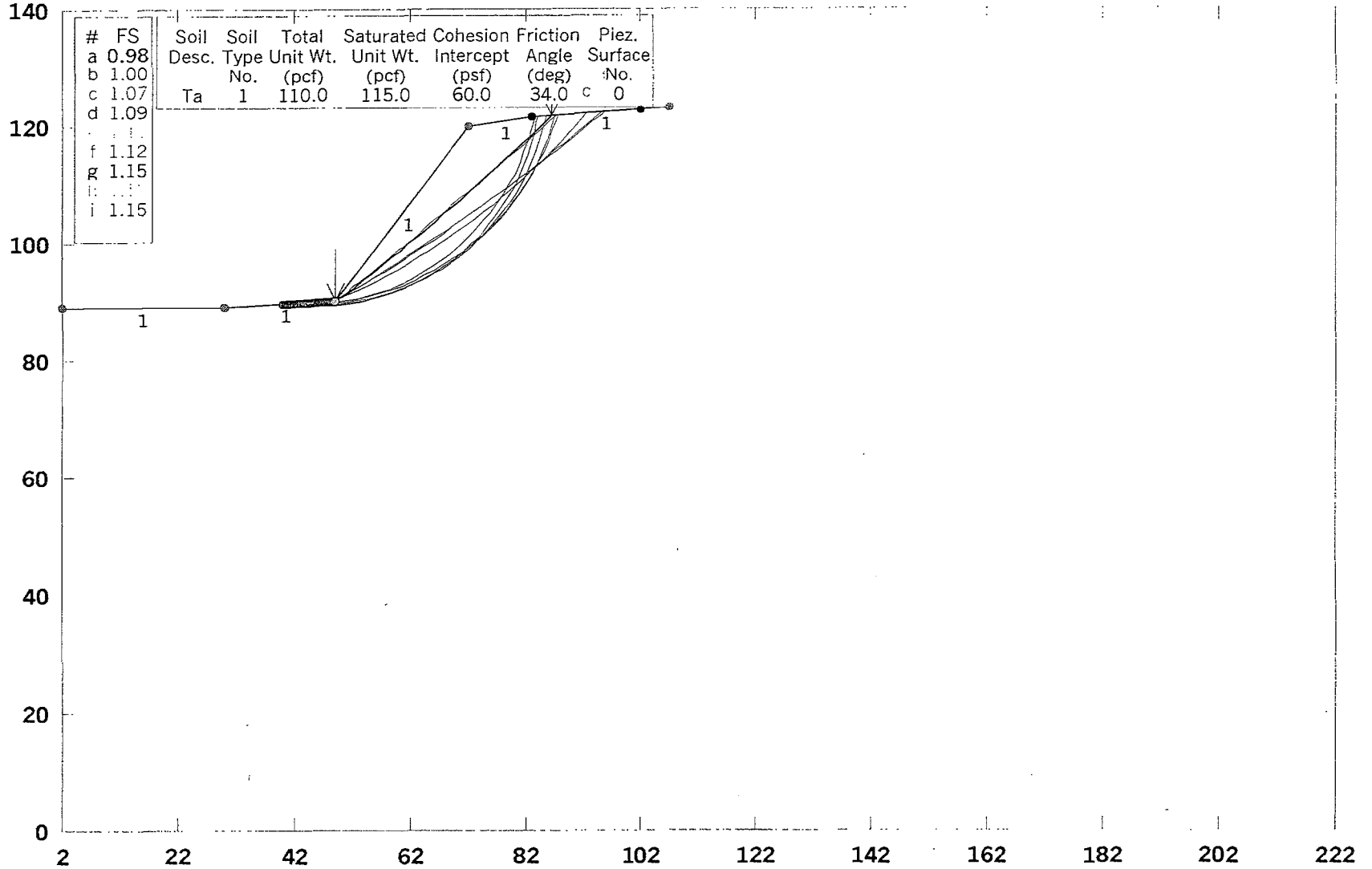

GSTABL7 v.2 FSmin=0.98

Safety Factors Are Calculated By The Modified Bishop Method

STED



*** GSTABL7 ***

** GSTABL7 by Garry H. Gregory, P.E. **

** Original Version 1.0, January 1996; Current Version 2.002, December 2001 **
 (All Rights Reserved-Unauthorized Use Prohibited)

SLOPE STABILITY ANALYSIS SYSTEM

Modified Bishop, Simplified Janbu, or GLE Method of Slices.
 (Includes Spencer & Morgenstern-Price Type Analysis)
 Including Pier/Pile, Reinforcement, Soil Nail, Tieback,
 Nonlinear Undrained Shear Strength, Curved Phi Envelope,
 Anisotropic Soil, Fiber-Reinforced Soil, Boundary Loads, Water
 Surfaces, Pseudo-Static Earthquake, and Applied Force Options.

Analysis Run Date: 4/2/02
 Time of Run: 10:43AM
 Run By: Username
 Input Data Filename: C:aa_prol.
 Output Filename: C:aa_prol.OUT
 Unit System: English
 Plotted Output Filename: C:aa_prol.PLT
 PROBLEM DESCRIPTION: 040596-001 TORREY PINES ROAD
 SECTION A-A'/ soil nail

BOUNDARY COORDINATES

Note: User origin value specified.
 Add 2.00 to X-values and 0.00 to Y-values listed.

9 Top Boundaries
 12 Total Boundaries

Boundary No.	X-Left (ft)	Y-Left (ft)	X-Right (ft)	Y-Right (ft)	Soil Type Below Bnd
1	2.00	89.00	29.00	89.00	1
2	29.00	89.00	33.00	99.00	1
3	33.00	99.00	38.50	114.00	2
4	38.50	114.00	46.50	115.00	2
5	46.50	115.00	56.00	116.00	1
6	56.00	116.00	56.10	115.00	1
7	56.10	115.00	62.00	115.00	1
8	62.00	115.00	65.00	119.00	1
9	65.00	119.00	72.00	120.00	1
10	33.00	99.00	41.50	110.00	1
11	41.50	110.00	46.00	113.00	1
12	46.00	113.00	46.50	115.00	1

Default Y-Origin = 0.00 (ft)

ISOTROPIC SOIL PARAMETERS

2 Type(s) of Soil

Soil Type No.	Total Unit Wt. (pcf)	Saturated Unit Wt. (pcf)	Cohesion Intercept (psf)	Friction Angle (deg)	Pore Pressure Param. (psf)	Pressure Constant (psf)	Piez. Surface No.
1	110.0	115.0	60.0	34.0	0.00	0.0	0
2	110.0	115.0	0.0	32.0	0.00	0.0	0

SOIL NAIL LOAD(S)

4 SOIL NAIL LOAD(S) SPECIFIED

Nail No.	X-Pos (ft)	Y-Pos (ft)	Nail Dia (in)	Tendon Dia (in)	Spacing (ft)	Inclin. (deg)	Length (ft)
1	29.80	91.00	6.0	1.0	6.00	18.00	15.00
2	32.20	97.00	6.0	1.0	6.00	18.00	15.00
3	34.47	103.00	6.0	1.0	6.00	18.00	15.00
4	36.67	109.00	6.0	1.0	6.00	18.00	20.00

SOIL NAIL LOAD DATA

Soil Nail No. 1 3 Load Points Apply to This Nail

Load Diagram Type = 2

POINT NO.	X-COORD. (ft)	Y-COORD. (ft)	FORCE (lbs)
1	29.80	91.00	6283.19
2	40.77	87.61	6283.19
3	44.07	86.36	0.00

Allowable Pullout Stress = 20000.0 (psf)

Allowable Tendon Stress = 48000.0(psi)
 Allowable Nail Head Load = 48000.0(lbs)
 Soil Nail No. 2 3 Load Points Apply to This Nail
 Load Diagram Type = 2

POINT NO.	X-COORD. (ft)	Y-COORD. (ft)	FORCE (lbs)
1	32.20	97.00	6283.19
2	43.05	93.65	6283.19
3	46.47	92.36	0.00

Allowable Pullout Stress = 20000.0(psf)
 Allowable Tendon Stress = 48000.0(psi)
 Allowable Nail Head Load = 48000.0(lbs)
 Soil Nail No. 3 3 Load Points Apply to This Nail
 Load Diagram Type = 2

POINT NO.	X-COORD. (ft)	Y-COORD. (ft)	FORCE (lbs)
1	34.47	103.00	6283.19
2	45.21	99.68	6283.19
3	48.73	98.36	0.00

Allowable Pullout Stress = 20000.0(psf)
 Allowable Tendon Stress = 48000.0(psi)
 Allowable Nail Head Load = 48000.0(lbs)
 Soil Nail No. 4 3 Load Points Apply to This Nail
 Load Diagram Type = 2

POINT NO.	X-COORD. (ft)	Y-COORD. (ft)	FORCE (lbs)
1	36.67	109.00	6283.19
2	51.82	104.32	6283.19
3	55.69	102.82	0.00

NOTE - An Equivalent Line Load Is Calculated For Each Row Of Soil Nails
 Assuming A Uniform Distribution Of Load Horizontally Between
 Individual Nails.

A Critical Failure Surface Searching Method, Using A Random
 Technique For Generating Circular Surfaces, Has Been Specified.
 500 Trial Surfaces Have Been Generated.
 10 Surface(s) Initiate(s) From Each Of 50 Points Equally Spaced
 Along The Ground Surface Between X = 10.00(ft)
 and X = 29.00(ft)
 Each Surface Terminates Between X = 40.00(ft)
 and X = 70.00(ft)

Unless Further Limitations Were Imposed, The Minimum Elevation
 At Which A Surface Extends Is Y = 0.00(ft)

1.00(ft) Line Segments Define Each Trial Failure Surface.
 Following Are Displayed The Ten Most Critical Of The Trial
 Failure Surfaces Evaluated. They Are
 Ordered - Most Critical First.

* * Safety Factors Are Calculated By The Modified Bishop Method * *
 Total Number of Trial Surfaces Evaluated = 500
 Statistical Data On All Valid FS Values:
 FS Max = 4.927 FS Min = 1.705 FS Ave = 1.894
 Standard Deviation = 0.189 Coefficient of Variation = 9.95 %
 Failure Surface Specified By 63 Coordinate Points

Point No.	X-Surf (ft)	Y-Surf (ft)
1	14.27	89.00
2	15.20	88.64
3	16.14	88.30
4	17.09	87.99
5	18.05	87.71
6	19.02	87.46
7	19.99	87.23
8	20.97	87.04
9	21.96	86.87
10	22.95	86.73
11	23.94	86.63
12	24.94	86.55

13	25.94	86.50
14	26.94	86.48
15	27.94	86.49
16	28.94	86.53
17	29.94	86.60
18	30.93	86.69
19	31.92	86.82
20	32.91	86.98
21	33.89	87.16
22	34.87	87.38
23	35.84	87.62
24	36.80	87.89
25	37.76	88.19
26	38.70	88.52
27	39.64	88.87
28	40.56	89.26
29	41.47	89.67
30	42.37	90.10
31	43.26	90.57
32	44.13	91.05
33	44.99	91.57
34	45.83	92.11
35	46.66	92.67
36	47.46	93.26
37	48.26	93.87
38	49.03	94.51
39	49.78	95.16
40	50.52	95.84
41	51.23	96.54
42	51.92	97.26
43	52.60	98.00
44	53.24	98.76
45	53.87	99.54
46	54.47	100.34
47	55.05	101.16
48	55.61	101.99
49	56.14	102.84
50	56.65	103.70
51	57.12	104.58
52	57.58	105.47
53	58.01	106.37
54	58.41	107.29
55	58.78	108.22
56	59.13	109.15
57	59.44	110.10
58	59.73	111.06
59	59.99	112.02
60	60.23	113.00
61	60.43	113.98
62	60.61	114.96
63	60.61	115.00

Circle Center At X = 27.11 ; Y = 120.42 ; and Radius = 33.94

Factor of Safety
 *** 1.705 ***

Slice No.	Width (ft)	Weight (lbs)	Individual data on the		70 slices		Earthquake		
			Force Top (lbs)	Force Bot (lbs)	Tie Norm (lbs)	Tie Tan (lbs)	Force Hor (lbs)	Force Ver (lbs)	Surcharge Load (lbs)
1	0.9	18.7	0.0	0.0	0.	0.	0.0	0.0	0.0
2	0.9	55.2	0.0	0.0	0.	0.	0.0	0.0	0.0
3	1.0	89.6	0.0	0.0	0.	0.	0.0	0.0	0.0
4	1.0	121.5	0.0	0.0	0.	0.	0.0	0.0	0.0
5	1.0	150.9	0.0	0.0	0.	0.	0.0	0.0	0.0
6	1.0	177.6	0.0	0.0	0.	0.	0.0	0.0	0.0
7	1.0	201.3	0.0	0.0	0.	0.	0.0	0.0	0.0

8	1.0	222.0	0.0	0.0	0.	0.	0.0	0.0	0.0
9	1.0	239.6	0.0	0.0	0.	0.	0.0	0.0	0.0
10	1.0	253.8	0.0	0.0	0.	0.	0.0	0.0	0.0
11	1.0	264.7	0.0	0.0	0.	0.	0.0	0.0	0.0
12	1.0	272.3	0.0	0.0	0.	0.	0.0	0.0	0.0
13	1.0	276.3	0.0	0.0	0.	0.	0.0	0.0	0.0
14	1.0	276.9	0.0	0.0	0.	0.	0.0	0.0	0.0
15	1.0	274.0	0.0	0.0	0.	0.	0.0	0.0	0.0
16	0.1	17.0	0.0	0.0	0.	0.	0.0	0.0	0.0
17	0.9	370.9	0.0	0.0	0.	0.	0.0	0.0	0.0
18	1.0	650.0	0.0	0.0	0.	0.	0.0	0.0	0.0
19	1.0	906.5	0.0	0.0	0.	0.	0.0	0.0	0.0
20	1.0	1156.2	0.0	0.0	0.	0.	0.0	0.0	0.0
21	0.1	117.9	0.0	0.0	0.	0.	0.0	0.0	0.0
22	0.9	1290.1	0.0	0.0	0.	0.	0.0	0.0	0.0
23	1.0	1665.0	0.0	0.0	0.	0.	0.0	0.0	0.0
24	1.0	1912.4	0.0	0.0	0.	0.	0.0	0.0	0.0
25	1.0	2149.2	0.0	0.0	0.	0.	0.0	0.0	0.0
26	1.0	2374.7	0.0	0.0	0.	0.	0.0	0.0	0.0
27	0.7	2019.0	0.0	0.0	0.	0.	0.0	0.0	0.0
28	0.2	563.4	0.0	0.0	0.	0.	0.0	0.0	0.0
29	0.9	2610.3	0.0	0.0	0.	0.	0.0	0.0	0.0
30	0.9	2554.2	0.0	0.0	0.	0.	0.0	0.0	0.0
31	0.9	2493.7	0.0	0.0	0.	0.	0.0	0.0	0.0
32	0.0	77.7	0.0	0.0	0.	0.	0.0	0.0	0.0
33	0.9	2351.2	0.0	0.0	0.	0.	0.0	0.0	0.0
34	0.9	2360.2	0.0	0.0	0.	0.	0.0	0.0	0.0
35	0.9	2287.8	0.0	0.0	0.	0.	0.0	0.0	0.0
36	0.9	2211.9	0.0	0.0	0.	0.	0.0	0.0	0.0
37	0.8	2133.0	0.0	0.0	0.	0.	0.0	0.0	0.0
38	0.2	426.1	0.0	0.0	0.	0.	0.0	0.0	0.0
39	0.5	1241.6	0.0	0.0	0.	0.	0.0	0.0	0.0
40	0.2	383.4	0.0	0.0	0.	0.	0.0	0.0	0.0
41	0.8	1965.9	0.0	0.0	0.	0.	0.0	0.0	0.0
42	0.8	1878.1	0.0	0.0	0.	0.	0.0	0.0	0.0
43	0.8	1788.5	0.0	0.0	0.	0.	0.0	0.0	0.0
44	0.8	1697.6	0.0	0.0	0.	0.	0.0	0.0	0.0
45	0.7	1605.7	0.0	0.0	0.	0.	0.0	0.0	0.0
46	0.7	1513.1	0.0	0.0	0.	0.	0.0	0.0	0.0
47	0.7	1420.2	0.0	0.0	0.	0.	0.0	0.0	0.0
48	0.7	1327.3	0.0	0.0	0.	0.	0.0	0.0	0.0
49	0.6	1234.9	0.0	0.0	0.	0.	0.0	0.0	0.0
50	0.6	1143.3	0.0	0.0	0.	0.	0.0	0.0	0.0
51	0.6	1052.9	0.0	0.0	0.	0.	0.0	0.0	0.0
52	0.6	964.0	0.0	0.0	0.	0.	0.0	0.0	0.0
53	0.6	877.1	0.0	0.0	0.	0.	0.0	0.0	0.0
54	0.4	588.1	0.0	0.0	0.	0.	0.0	0.0	0.0
55	0.1	140.9	0.0	0.0	0.	0.	0.0	0.0	0.0
56	0.0	53.3	0.0	0.0	0.	0.	0.0	0.0	0.0
57	0.5	652.3	0.0	0.0	0.	0.	0.0	0.0	0.0
58	0.5	573.3	0.0	0.0	0.	0.	0.0	0.0	0.0
59	0.5	498.0	0.0	0.0	0.	0.	0.0	0.0	0.0
60	0.4	426.8	0.0	0.0	0.	0.	0.0	0.0	0.0
61	0.4	359.9	0.0	0.0	0.	0.	0.0	0.0	0.0
62	0.4	297.6	0.0	0.0	0.	0.	0.0	0.0	0.0
63	0.3	240.2	0.0	0.0	0.	0.	0.0	0.0	0.0
64	0.3	187.9	0.0	0.0	0.	0.	0.0	0.0	0.0
65	0.3	141.0	0.0	0.0	0.	0.	0.0	0.0	0.0
66	0.3	99.5	0.0	0.0	0.	0.	0.0	0.0	0.0
67	0.2	63.8	0.0	0.0	0.	0.	0.0	0.0	0.0
68	0.2	34.0	0.0	0.0	0.	0.	0.0	0.0	0.0
69	0.2	10.3	0.0	0.0	0.	0.	0.0	0.0	0.0
70	0.0	0.0	0.0	0.0	0.	0.	0.0	0.0	0.0

Failure Surface Specified By 61 Coordinate Points

Point No.	X-Surf (ft)	Y-Surf (ft)
-----------	-------------	-------------

1	16.20	89.00
2	17.14	88.64
3	18.08	88.32
4	19.04	88.02
5	20.00	87.75
6	20.97	87.51
7	21.95	87.30
8	22.93	87.12
9	23.92	86.97
10	24.92	86.85
11	25.91	86.76
12	26.91	86.70
13	27.91	86.67
14	28.91	86.68
15	29.91	86.71
16	30.91	86.77
17	31.90	86.87
18	32.89	86.99
19	33.88	87.15
20	34.86	87.33
21	35.84	87.55
22	36.81	87.79
23	37.77	88.07
24	38.73	88.37
25	39.67	88.70
26	40.60	89.07
27	41.52	89.45
28	42.43	89.87
29	43.33	90.32
30	44.21	90.79
31	45.07	91.29
32	45.92	91.81
33	46.76	92.37
34	47.58	92.94
35	48.38	93.54
36	49.16	94.17
37	49.92	94.82
38	50.66	95.49
39	51.38	96.18
40	52.08	96.90
41	52.75	97.64
42	53.41	98.39
43	54.03	99.17
44	54.64	99.97
45	55.22	100.78
46	55.78	101.61
47	56.31	102.46
48	56.81	103.32
49	57.29	104.20
50	57.74	105.09
51	58.16	106.00
52	58.56	106.92
53	58.92	107.85
54	59.26	108.79
55	59.57	109.74
56	59.85	110.70
57	60.10	111.67
58	60.32	112.64
59	60.51	113.63
60	60.67	114.61
61	60.72	115.00

Circle Center At X = 28.32 ; Y = 119.37 ; and Radius = 32.70
 Factor of Safety
 *** 1.716 ***
 Failure Surface Specified By 64 Coordinate Points
 Point X-Surf Y-Surf

No.	(ft)	(ft)
1	14.65	89.00
2	15.60	88.68
3	16.56	88.39
4	17.52	88.13
5	18.49	87.89
6	19.47	87.67
7	20.45	87.49
8	21.44	87.33
9	22.43	87.20
10	23.43	87.09
11	24.42	87.01
12	25.42	86.96
13	26.42	86.94
14	27.42	86.95
15	28.42	86.98
16	29.42	87.04
17	30.42	87.12
18	31.41	87.23
19	32.40	87.37
20	33.39	87.54
21	34.37	87.74
22	35.34	87.96
23	36.31	88.20
24	37.27	88.48
25	38.23	88.78
26	39.17	89.10
27	40.11	89.45
28	41.04	89.83
29	41.95	90.23
30	42.86	90.66
31	43.75	91.11
32	44.63	91.58
33	45.49	92.08
34	46.35	92.60
35	47.19	93.15
36	48.01	93.72
37	48.82	94.31
38	49.61	94.92
39	50.38	95.55
40	51.14	96.21
41	51.87	96.88
42	52.59	97.58
43	53.29	98.29
44	53.97	99.02
45	54.63	99.78
46	55.27	100.54
47	55.89	101.33
48	56.49	102.13
49	57.06	102.95
50	57.61	103.79
51	58.14	104.63
52	58.65	105.50
53	59.13	106.37
54	59.59	107.26
55	60.02	108.16
56	60.43	109.08
57	60.81	110.00
58	61.17	110.93
59	61.51	111.88
60	61.81	112.83
61	62.09	113.79
62	62.35	114.75
63	62.58	115.73
64	62.59	115.78

Circle Center At X = 26.77 ; Y = 123.60 ; and Radius = 36.66

Factor of Safety		
*** 1.717 ***		
Failure Surface Specified By 75 Coordinate Points		
Point No.	X-Surf (ft)	Y-Surf (ft)
1	11.16	89.00
2	12.12	88.72
3	13.09	88.46
4	14.06	88.22
5	15.04	88.00
6	16.02	87.80
7	17.00	87.62
8	17.99	87.47
9	18.98	87.33
10	19.97	87.21
11	20.97	87.12
12	21.96	87.05
13	22.96	87.00
14	23.96	86.97
15	24.96	86.96
16	25.96	86.97
17	26.96	87.00
18	27.96	87.06
19	28.96	87.13
20	29.95	87.23
21	30.95	87.35
22	31.94	87.49
23	32.92	87.65
24	33.91	87.83
25	34.89	88.03
26	35.86	88.25
27	36.83	88.50
28	37.80	88.76
29	38.75	89.04
30	39.71	89.35
31	40.65	89.67
32	41.59	90.02
33	42.52	90.38
34	43.45	90.77
35	44.36	91.17
36	45.27	91.59
37	46.16	92.03
38	47.05	92.49
39	47.93	92.97
40	48.80	93.47
41	49.65	93.99
42	50.50	94.52
43	51.33	95.08
44	52.15	95.65
45	52.96	96.23
46	53.76	96.84
47	54.54	97.46
48	55.31	98.10
49	56.07	98.75
50	56.81	99.42
51	57.54	100.10
52	58.25	100.80
53	58.95	101.52
54	59.64	102.25
55	60.30	103.00
56	60.96	103.75
57	61.59	104.53
58	62.21	105.31
59	62.81	106.11
60	63.40	106.92
61	63.96	107.74

62	64.51	108.58	
63	65.05	109.43	
64	65.56	110.28	
65	66.06	111.15	
66	66.53	112.03	
67	66.99	112.92	
68	67.43	113.82	
69	67.85	114.73	
70	68.25	115.64	
71	68.63	116.57	
72	69.00	117.50	
73	69.34	118.44	
74	69.66	119.38	
75	69.75	119.68	

Circle Center At X = 24.89 ; Y = 134.08 ; and Radius = 47.12
 Factor of Safety
 *** 1.720 ***

Failure Surface Specified By 65 Coordinate Points

Point No.	X-Surf (ft)	Y-Surf* (ft)
1	16.59	89.00
2	17.55	88.71
3	18.52	88.45
4	19.49	88.22
5	20.47	88.01
6	21.45	87.83
7	22.44	87.67
8	23.43	87.55
9	24.42	87.44
10	25.42	87.37
11	26.42	87.32
12	27.42	87.30
13	28.42	87.30
14	29.42	87.34
15	30.42	87.40
16	31.41	87.48
17	32.41	87.60
18	33.40	87.74
19	34.38	87.90
20	35.36	88.10
21	36.34	88.31
22	37.31	88.56
23	38.27	88.83
24	39.23	89.13
25	40.17	89.45
26	41.11	89.80
27	42.04	90.17
28	42.96	90.57
29	43.86	90.99
30	44.76	91.44
31	45.64	91.91
32	46.51	92.40
33	47.36	92.92
34	48.21	93.46
35	49.03	94.03
36	49.84	94.61
37	50.64	95.22
38	51.42	95.84
39	52.18	96.49
40	52.92	97.16
41	53.65	97.85
42	54.35	98.56
43	55.04	99.28
44	55.71	100.03
45	56.36	100.79
46	56.98	101.57

47	57.59	102.37
48	58.17	103.18
49	58.73	104.01
50	59.27	104.85
51	59.79	105.70
52	60.28	106.57
53	60.75	107.46
54	61.20	108.35
55	61.62	109.26
56	62.02	110.18
57	62.39	111.11
58	62.73	112.04
59	63.05	112.99
60	63.35	113.95
61	63.62	114.91
62	63.86	115.88
63	64.08	116.85
64	64.27	117.84
65	64.32	118.09

Circle Center At X = 27.71 ; Y = 124.46 ; and Radius = 37.16

Factor of Safety
 *** 1.722 ***

Failure Surface Specified By 66 Coordinate Points

Point No.	X-Surf (ft)	Y-Surf (ft)
1	15.04	89.00
2	16.00	88.71
3	16.96	88.45
4	17.93	88.21
5	18.91	87.99
6	19.89	87.80
7	20.88	87.64
8	21.87	87.50
9	22.86	87.39
10	23.86	87.30
11	24.86	87.24
12	25.86	87.21
13	26.86	87.20
14	27.86	87.22
15	28.86	87.26
16	29.85	87.33
17	30.85	87.43
18	31.84	87.55
19	32.83	87.69
20	33.82	87.87
21	34.80	88.07
22	35.77	88.29
23	36.74	88.54
24	37.70	88.81
25	38.65	89.11
26	39.60	89.43
27	40.54	89.78
28	41.47	90.15
29	42.38	90.55
30	43.29	90.97
31	44.19	91.41
32	45.07	91.88
33	45.94	92.37
34	46.80	92.88
35	47.65	93.42
36	48.48	93.97
37	49.30	94.55
38	50.10	95.15
39	50.88	95.77
40	51.65	96.41
41	52.41	97.06

42	53.14	97.74
43	53.86	98.44
44	54.56	99.15
45	55.24	99.89
46	55.90	100.64
47	56.54	101.41
48	57.16	102.19
49	57.76	102.99
50	58.34	103.81
51	58.90	104.64
52	59.43	105.48
53	59.94	106.34
54	60.44	107.21
55	60.90	108.09
56	61.35	108.99
57	61.77	109.89
58	62.17	110.81
59	62.55	111.74
60	62.90	112.68
61	63.22	113.62
62	63.52	114.57
63	63.80	115.54
64	64.05	116.50
65	64.28	117.48
66	64.43	118.24

Circle Center At X = 26.68 ; Y = 125.68 ; and Radius = 38.48

Factor of Safety
 *** 1.724 ***

Failure Surface Specified By 60 Coordinate Points

Point No.	X-Surf (ft)	Y-Surf (ft)
1	15.82	89.00
2	16.76	88.66
3	17.71	88.36
4	18.67	88.08
5	19.64	87.83
6	20.61	87.61
7	21.60	87.42
8	22.58	87.26
9	23.57	87.13
10	24.57	87.03
11	25.57	86.96
12	26.57	86.92
13	27.57	86.92
14	28.57	86.94
15	29.57	86.99
16	30.56	87.08
17	31.56	87.19
18	32.54	87.33
19	33.53	87.51
20	34.51	87.71
21	35.48	87.95
22	36.45	88.21
23	37.40	88.50
24	38.35	88.82
25	39.28	89.18
26	40.21	89.55
27	41.12	89.96
28	42.02	90.40
29	42.91	90.86
30	43.78	91.35
31	44.64	91.86
32	45.48	92.40
33	46.30	92.97
34	47.11	93.56
35	47.90	94.18

36	48.67	94.82
37	49.42	95.48
38	50.14	96.17
39	50.85	96.87
40	51.54	97.60
41	52.20	98.35
42	52.84	99.12
43	53.45	99.91
44	54.05	100.71
45	54.61	101.54
46	55.15	102.38
47	55.67	103.24
48	56.16	104.11
49	56.62	104.99
50	57.05	105.90
51	57.46	106.81
52	57.84	107.73
53	58.19	108.67
54	58.51	109.62
55	58.81	110.57
56	59.07	111.54
57	59.30	112.51
58	59.51	113.49
59	59.68	114.47
60	59.76	115.00

Circle Center At X = 27.32 ; Y = 119.69 ; and Radius = 32.77

Factor of Safety

*** 1.726 ***

Failure Surface Specified By 68 Coordinate Points

Point No.	X-Surf (ft)	Y-Surf (ft)
1	15.04	89.00
2	16.00	88.70
3	16.96	88.43
4	17.93	88.18
5	18.90	87.96
6	19.88	87.76
7	20.87	87.59
8	21.86	87.44
9	22.85	87.31
10	23.84	87.22
11	24.84	87.14
12	25.84	87.09
13	26.84	87.07
14	27.84	87.07
15	28.84	87.10
16	29.84	87.16
17	30.83	87.24
18	31.83	87.34
19	32.82	87.47
20	33.81	87.62
21	34.79	87.80
22	35.77	88.01
23	36.74	88.24
24	37.71	88.49
25	38.67	88.77
26	39.62	89.07
27	40.57	89.40
28	41.51	89.75
29	42.43	90.12
30	43.35	90.52
31	44.26	90.94
32	45.16	91.38
33	46.04	91.85
34	46.91	92.34
35	47.77	92.85

36	48.62	93.38
37	49.45	93.93
38	50.27	94.51
39	51.07	95.10
40	51.86	95.72
41	52.64	96.35
42	53.39	97.01
43	54.13	97.68
44	54.85	98.37
45	55.56	99.08
46	56.24	99.81
47	56.91	100.55
48	57.56	101.32
49	58.19	102.09
50	58.80	102.89
51	59.39	103.69
52	59.95	104.52
53	60.50	105.36
54	61.03	106.21
55	61.53	107.07
56	62.01	107.95
57	62.47	108.83
58	62.91	109.73
59	63.32	110.64
60	63.71	111.57
61	64.08	112.50
62	64.42	113.44
63	64.74	114.38
64	65.04	115.34
65	65.31	116.30
66	65.55	117.27
67	65.77	118.25
68	65.95	119.14

Circle Center At X = 27.23 ; Y = 126.49 ; and Radius = 39.42

Factor of Safety
 *** 1.727 ***

Failure Surface Specified By 75 Coordinate Points

Point No.	X-Surf (ft)	Y-Surf (ft)
1	10.39	89.00
2	11.33	88.68
3	12.29	88.37
4	13.25	88.09
5	14.21	87.83
6	15.18	87.59
7	16.16	87.38
8	17.14	87.18
9	18.13	87.01
10	19.12	86.86
11	20.11	86.74
12	21.10	86.63
13	22.10	86.55
14	23.10	86.49
15	24.10	86.46
16	25.10	86.44
17	26.10	86.45
18	27.10	86.48
19	28.09	86.54
20	29.09	86.61
21	30.09	86.71
22	31.08	86.84
23	32.07	86.98
24	33.05	87.15
25	34.04	87.34
26	35.01	87.55
27	35.99	87.78

28	36.95	88.04
29	37.91	88.31
30	38.87	88.61
31	39.82	88.93
32	40.76	89.27
33	41.69	89.64
34	42.61	90.02
35	43.53	90.42
36	44.43	90.85
37	45.33	91.29
38	46.21	91.76
39	47.08	92.25
40	47.95	92.75
41	48.80	93.28
42	49.64	93.82
43	50.46	94.38
44	51.28	94.96
45	52.08	95.56
46	52.87	96.18
47	53.64	96.82
48	54.40	97.47
49	55.14	98.14
50	55.87	98.82
51	56.58	99.53
52	57.27	100.24
53	57.95	100.98
54	58.62	101.73
55	59.26	102.49
56	59.89	103.27
57	60.50	104.06
58	61.09	104.87
59	61.67	105.69
60	62.22	106.52
61	62.76	107.36
62	63.27	108.22
63	63.77	109.09
64	64.25	109.96
65	64.70	110.85
66	65.14	111.75
67	65.56	112.66
68	65.96	113.58
69	66.33	114.51
70	66.68	115.44
71	67.02	116.39
72	67.33	117.34
73	67.62	118.29
74	67.89	119.26
75	67.93	119.42

Circle Center At X = 25.20 ; Y = 130.62 ; and Radius = 44.17

Factor of Safety
 *** 1.729 ***

Failure Surface Specified By 72 Coordinate Points

Point No.	X-Surf (ft)	Y-Surf (ft)
1	13.49	89.00
2	14.46	88.77
3	15.44	88.56
4	16.42	88.37
5	17.41	88.20
6	18.40	88.06
7	19.39	87.93
8	20.38	87.82
9	21.38	87.74
10	22.38	87.67
11	23.38	87.63
12	24.38	87.61

13	25.38	87.61
14	26.38	87.63
15	27.38	87.67
16	28.37	87.73
17	29.37	87.81
18	30.37	87.91
19	31.36	88.04
20	32.35	88.18
21	33.33	88.35
22	34.32	88.54
23	35.29	88.74
24	36.27	88.97
25	37.24	89.22
26	38.20	89.49
27	39.16	89.77
28	40.11	90.08
29	41.05	90.41
30	41.99	90.76
31	42.92	91.13
32	43.84	91.51
33	44.76	91.92
34	45.66	92.35
35	46.56	92.79
36	47.44	93.25
37	48.32	93.73
38	49.19	94.23
39	50.04	94.75
40	50.89	95.29
41	51.72	95.84
42	52.54	96.41
43	53.35	97.00
44	54.15	97.60
45	54.93	98.22
46	55.70	98.86
47	56.46	99.51
48	57.20	100.18
49	57.93	100.87
50	58.65	101.57
51	59.34	102.28
52	60.03	103.01
53	60.70	103.75
54	61.35	104.51
55	61.99	105.28
56	62.61	106.07
57	63.21	106.86
58	63.80	107.67
59	64.37	108.49
60	64.92	109.33
61	65.46	110.17
62	65.98	111.03
63	66.48	111.89
64	66.96	112.77
65	67.42	113.66
66	67.86	114.55
67	68.29	115.46
68	68.70	116.37
69	69.08	117.29
70	69.45	118.22
71	69.80	119.16
72	69.99	119.71

Circle Center At X = 24.94 ; Y = 135.26 ; and Radius = 47.66

Factor of Safety
 *** 1.730 ***

**** END OF GSTABL7 OUTPUT ****

Section B-B

040596-001 TORREY PINES ROAD SECTION B-B' existing topo

C:\KEN\SLOPES~1\040596~1\REVISE~1\B-B'BB_RUN3.PL2 Run By: Username 4/2/02 10:53AM

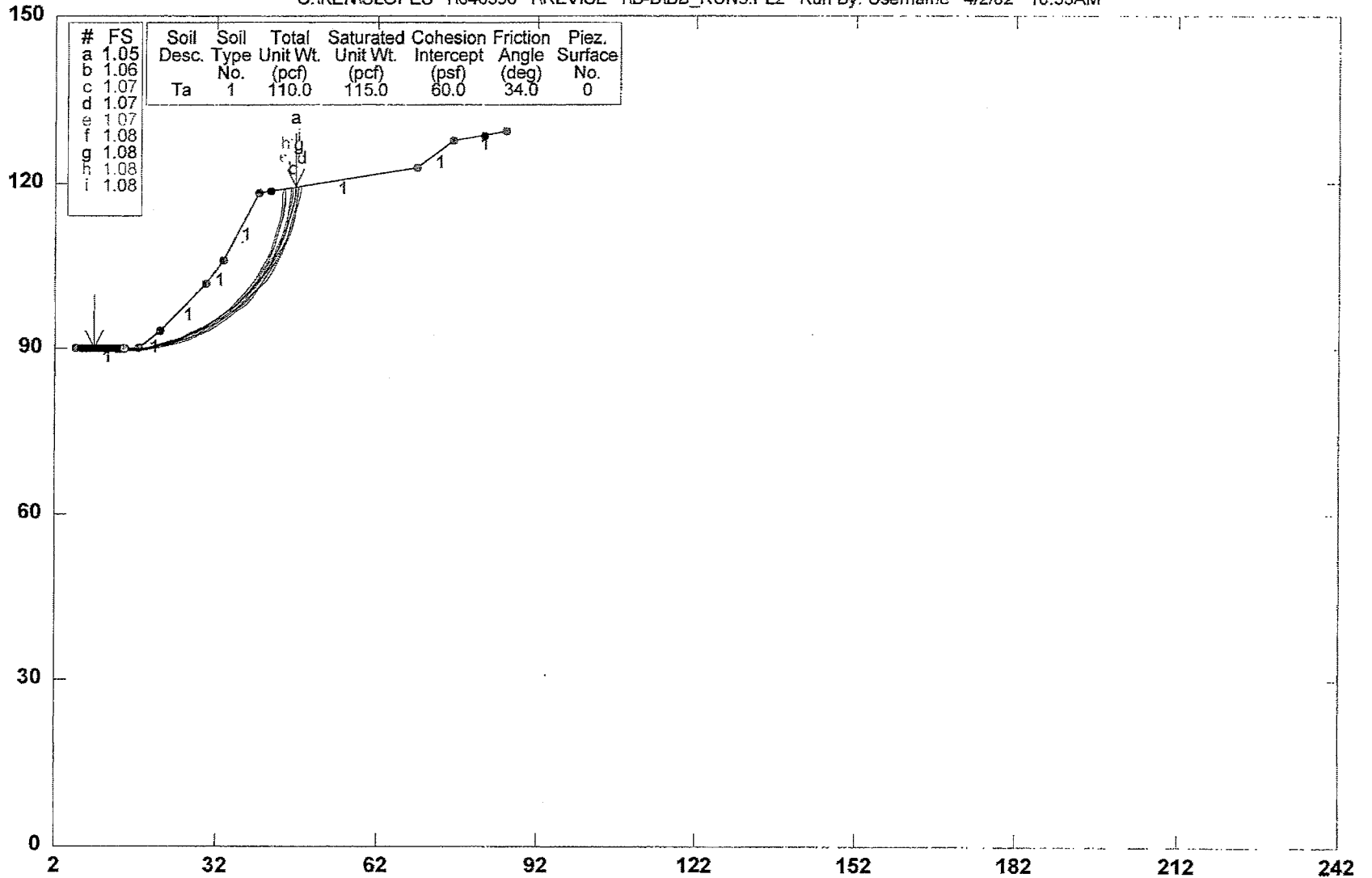

GSTABL7 FSmin=1.05

Safety Factors Are Calculated By The Modified Bishop Method

STED



040596-001 TORREY PINES ROAD SECTION B-B'/temp cut for soil nails

C:\KENSLOPES~1\040596~1\REVISE~1\B-B\BB_TEMP1.PL2 Run By: Username 4/2/02 10:54AM

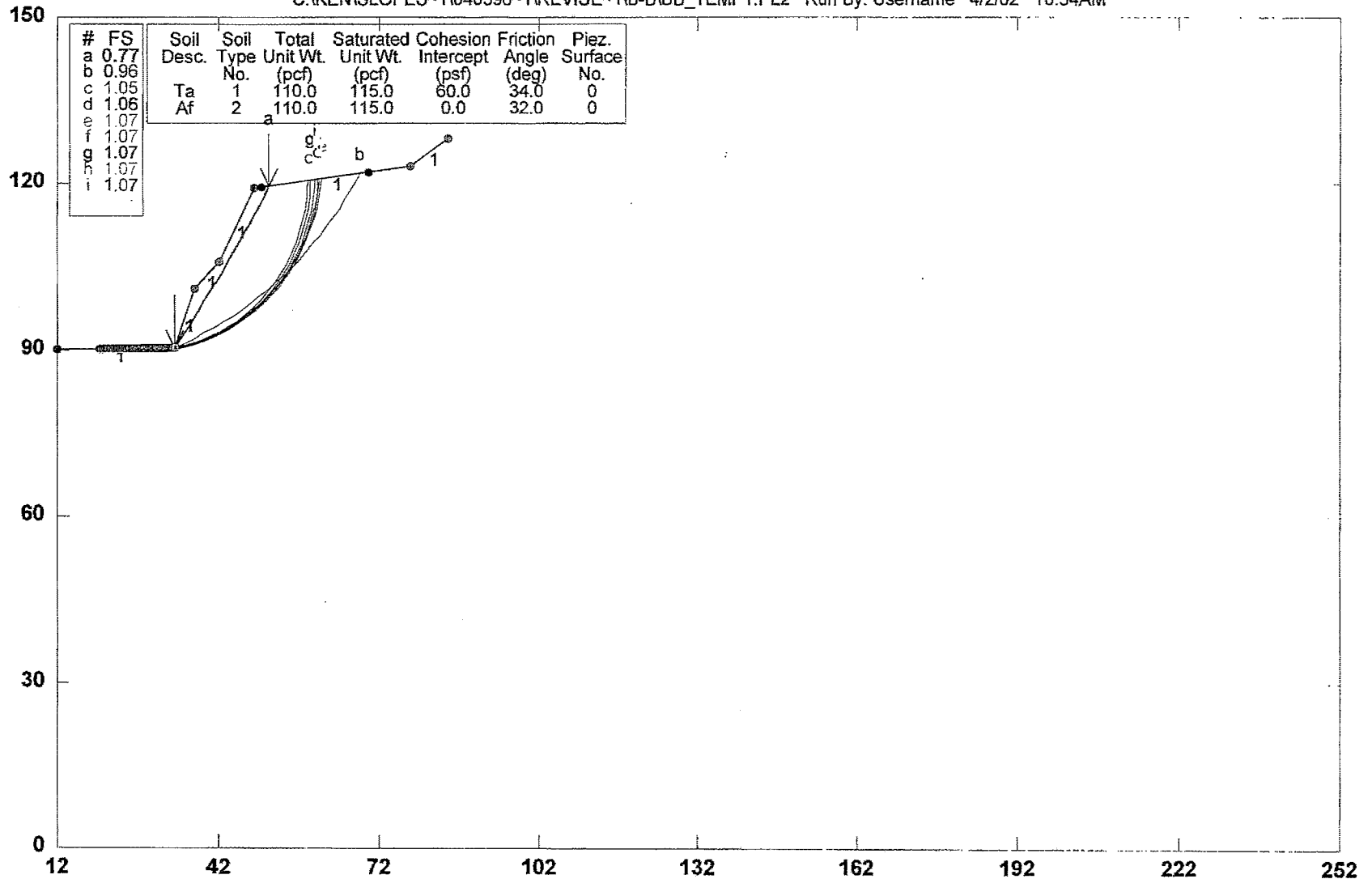

GSTABL7 v.2 FSmin=0.77

Safety Factors Are Calculated By The Modified Bishop Method

STED



040596-001 TORREY PINES ROAD SECTION B-B'/soil nails

C:\KEN\SLOPES~1\040596~1\REVISE~1\B-B\BB_PRO1.PL2 Run By: Username 4/2/02 10:55AM

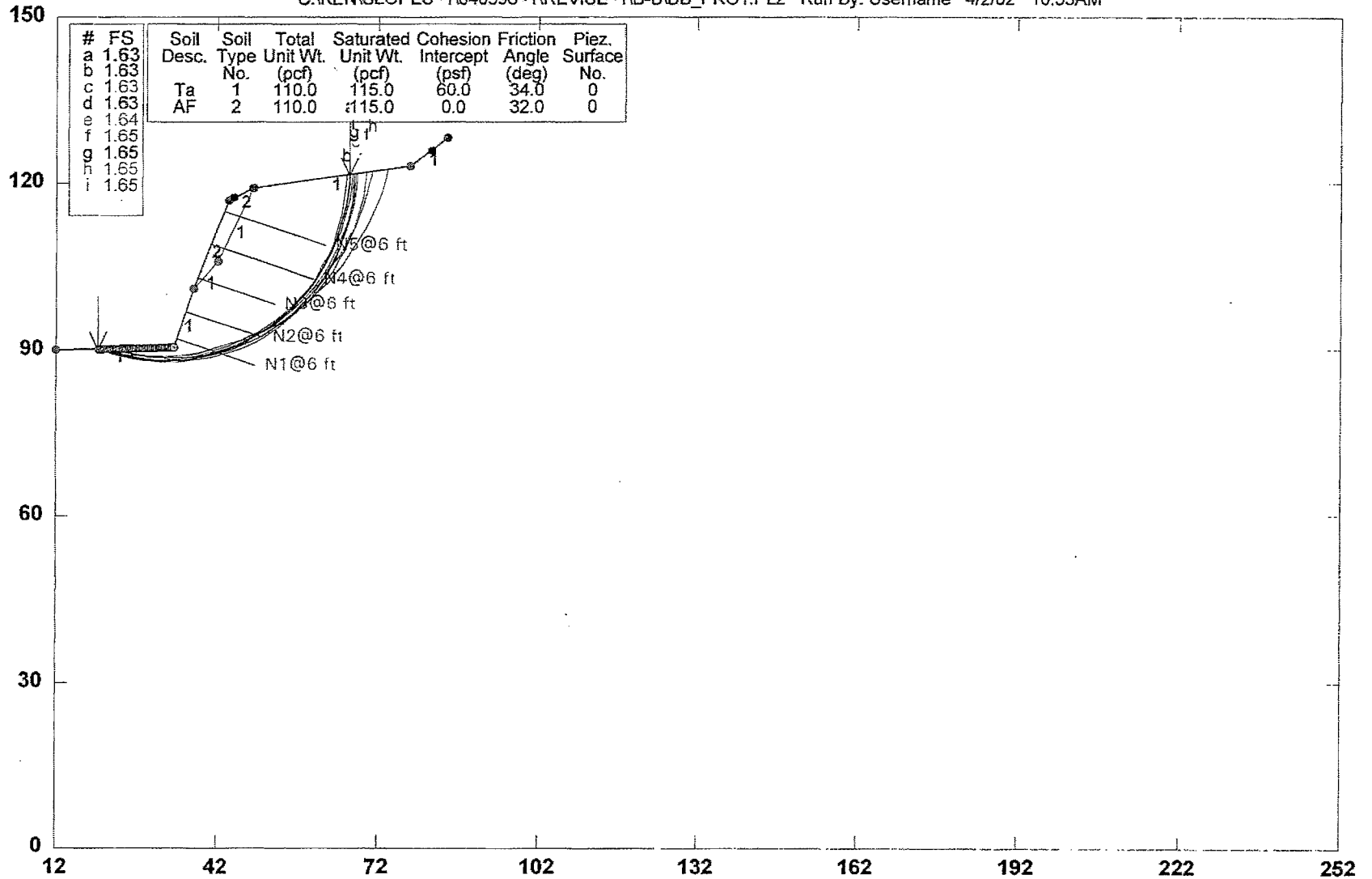

GSTABL7 v.2 FSmin=1.63

Safety Factors Are Calculated By The Modified Bishop Method

STED



040596-001 TORREY PINES ROAD SECTION B-B'/soil nails w/seismic

C:\KEN\SLOPES~1\040596~1\REVISE~1\B-B'BB_PRO3.PL2 Run By: Username 4/2/02 11:01AM

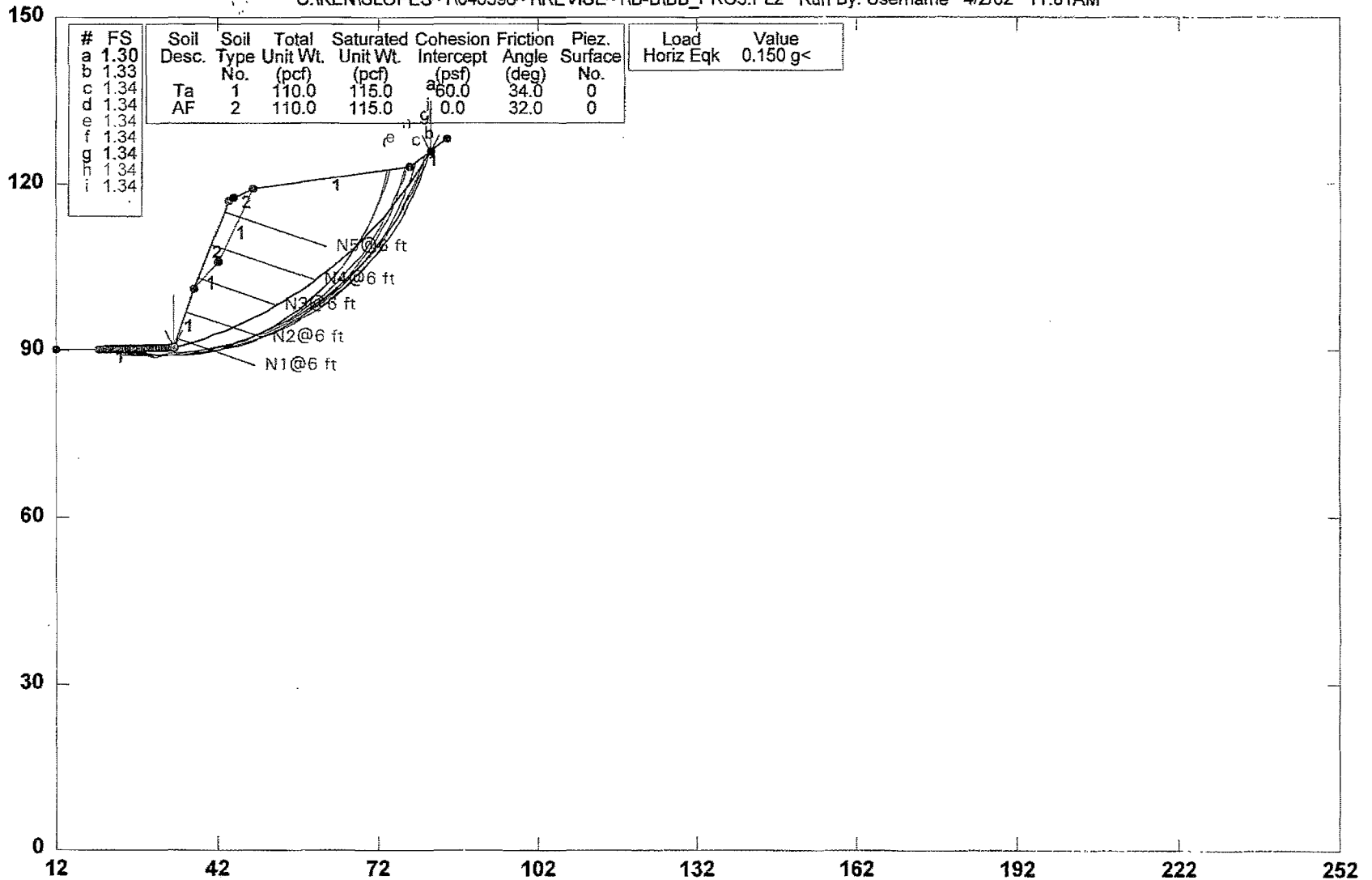

GSTABL7 v.2 FSmin=1.30

Safety Factors Are Calculated By The Modified Bishop Method

STED



040596-001 TORREY PINES ROAD SECTION B-B'/soil nails w/seismic

C:\KEN\SLOPES~1\040596~1\REVISE~1\B-B\BB_PRO3.PL2 Run By: Username 4/2/02 11:00AM

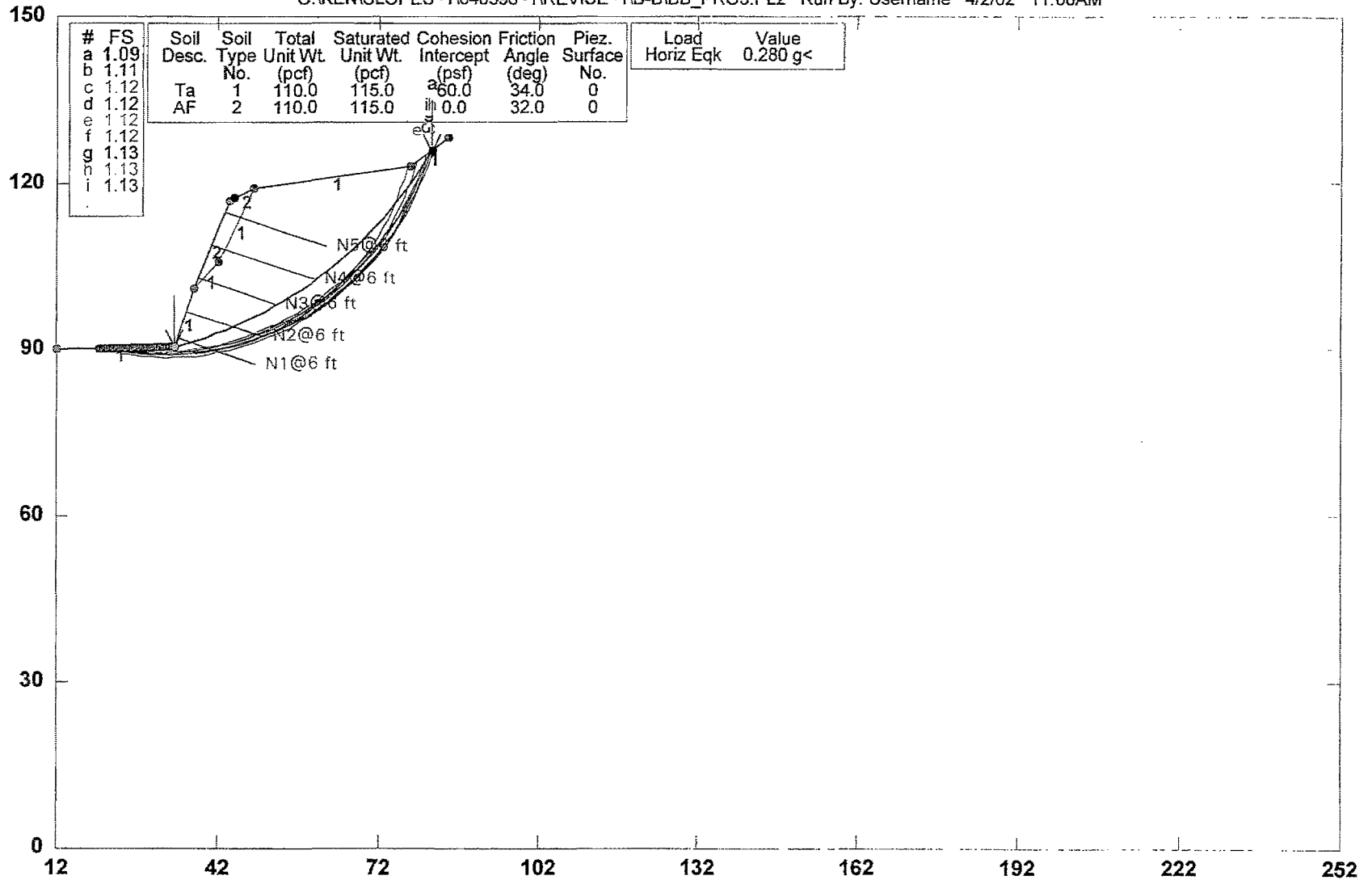

GSTABL7 v.2 FSmin=1.09

Safety Factors Are Calculated By The Modified Bishop Method

STED



*** GSTABL7 ***

** GSTABL7 by Garry H. Gregory, P.E. **

** Original Version 1.0, January 1996; Current Version 2.002, December 2001 **
 (All Rights Reserved-Unauthorized Use Prohibited)

SLOPE STABILITY ANALYSIS SYSTEM

Modified Bishop, Simplified Janbu, or GLE Method of Slices,
 (Includes Spencer & Morgenstern-Price Type Analysis)
 Including Pier/Pile, Reinforcement, Soil Nail, Tieback,
 Nonlinear Undrained Shear Strength, Curved Phi Envelope,
 Anisotropic Soil, Fiber-Reinforced Soil, Boundary Loads, Water
 Surfaces, Pseudo-Static Earthquake, and Applied Force Options.

Analysis Run Date: 4/2/02
 Time of Run: 10:55AM
 Run By: Username
 Input Data Filename: C:bb_prol.
 Output Filename: C:bb_prol.OUT
 Unit System: English
 Plotted Output Filename: C:bb_prol.PLT
 PROBLEM DESCRIPTION: 040596-001 TORREY PINES ROAD
 SECTION B-B'/soil nails

BOUNDARY COORDINATES

Note: User origin value specified.
 Add 12.00 to X-values and 0.00 to Y-values listed.

6 Top Boundaries
 8 Total Boundaries

Boundary No.	X-Left (ft)	Y-Left (ft)	X-Right (ft)	Y-Right (ft)	Soil Type Below Bnd
1	12.00	90.00	34.00	90.50	1
2	34.00	90.50	37.50	101.00	1
3	37.50	101.00	44.00	117.00	2
4	44.00	117.00	48.50	119.00	2
5	48.50	119.00	78.00	123.00	1
6	78.00	123.00	85.00	128.00	1
7	37.50	101.00	42.00	106.00	1
8	42.00	106.00	48.50	119.00	1

Default Y-Origin = 0.00(ft)

ISOTROPIC SOIL PARAMETERS

2 Type(s) of Soil

Type No.	Total Unit Wt. (pcf)	Saturated Unit Wt. (pcf)	Cohesion Intercept (psf)	Friction Angle (deg)	Pore Pressure Param. (psf)	Pressure Constant (psf)	Piez. Surface No.
1	110.0	115.0	60.0	34.0	0.00	0.0	0
2	110.0	115.0	0.0	32.0	0.00	0.0	0

SOIL NAIL LOAD(S)

5 SOIL NAIL LOAD(S) SPECIFIED

Nail No.	X-Pos (ft)	Y-Pos (ft)	Nail Dia (in)	Tendon Dia (in)	Spacing (ft)	Inclin. (deg)	Length (ft)
1	34.50	92.00	6.0	1.0	6.00	18.00	15.00
2	36.17	97.00	6.0	1.0	6.00	18.00	15.00
3	38.31	103.00	6.0	1.0	6.00	18.00	15.00
4	40.75	109.00	6.0	1.0	6.00	18.00	20.00
5	43.19	115.00	6.0	1.0	6.00	18.00	20.00

SOIL NAIL LOAD DATA

Soil Nail No. 1 3 Load Points Apply to This Nail

Load Diagram Type = 2

POINT NO.	X-COORD. (ft)	Y-COORD. (ft)	FORCE (lbs)
1	34.50	92.00	6283.19
2	45.24	88.68	6283.19
3	48.77	87.36	0.00

Allowable Pullout Stress = 20000.0(psf)

Allowable Tendon Stress = 48000.0(psi)

Allowable Nail Head Load = 48000.0(lbs)

Soil Nail No. 2 3 Load Points Apply to This Nail

Load Diagram Type = 2
 POINT NO. X-COORD.(ft) Y-COORD.(ft) FORCE(lbs)
 1 36.17 97.00 6283.19
 2 46.82 93.71 6283.19
 3 50.43 92.36 0.00
 Allowable Pullout Stress = 20000.0(psf)
 Allowable Tendon Stress = 48000.0(psi)
 Allowable Nail Head Load = 48000.0(lbs)
 Soil Nail No. 3 3 Load Points Apply to This Nail

Load Diagram Type = 2
 POINT NO. X-COORD.(ft) Y-COORD.(ft) FORCE(lbs)
 1 38.31 103.00 6283.19
 2 48.86 99.74 6283.19
 3 52.58 98.36 0.00
 Allowable Pullout Stress = 20000.0(psf)
 Allowable Tendon Stress = 48000.0(psi)
 Allowable Nail Head Load = 48000.0(lbs)
 Soil Nail No. 4 3 Load Points Apply to This Nail

Load Diagram Type = 2
 POINT NO. X-COORD.(ft) Y-COORD.(ft) FORCE(lbs)
 1 40.75 109.00 6283.19
 2 55.70 104.38 6283.19
 3 59.77 102.82 0.00
 Allowable Pullout Stress = 20000.0(psf)
 Allowable Tendon Stress = 48000.0(psi)
 Allowable Nail Head Load = 48000.0(lbs)
 Soil Nail No. 5 3 Load Points Apply to This Nail

Load Diagram Type = 2
 POINT NO. X-COORD.(ft) Y-COORD.(ft) FORCE(lbs)
 1 43.19 115.00 6283.19
 2 58.02 110.42 6283.19
 3 62.21 108.82 0.00
 Allowable Pullout Stress = 20000.0(psf)
 Allowable Tendon Stress = 48000.0(psi)
 Allowable Nail Head Load = 48000.0(lbs)

NOTE - An Equivalent Line Load Is Calculated For Each Row Of Soil Nails
 Assuming A Uniform Distribution Of Load Horizontally Between
 Individual Nails.

A Critical Failure Surface Searching Method, Using A Random
 Technique For Generating Circular Surfaces, Has Been Specified.
 500 Trial Surfaces Have Been Generated.

10 Surface(s) Initiate(s) From Each Of 50 Points Equally Spaced
 Along The Ground Surface Between X = 20.00(ft)
 and X = 34.00(ft)
 Each Surface Terminates Between X = 45.00(ft)
 and X = 82.00(ft)

Unless Further Limitations Were Imposed, The Minimum Elevation
 At Which A Surface Extends Is Y = 0.00(ft)
 2.00(ft) Line Segments Define Each Trial Failure Surface.

Following Are Displayed The Ten Most Critical Of The Trial
 Failure Surfaces Evaluated. They Are
 Ordered - Most Critical First.

* * Safety Factors Are Calculated By The Modified Bishop Method * *
 Total Number of Trial Surfaces Evaluated = 500
 Statistical Data On All Valid FS Values:
 FS Max = 6.706 FS Min = 1.629 FS Ave = 1.880
 Standard Deviation = 0.275 Coefficient of Variation = 14.64 %
 Failure Surface Specified By 34 Coordinate Points

Point No.	X-Surf (ft)	Y-Surf (ft)
1	20.00	90.18
2	21.90	89.55
3	23.83	89.02
4	25.78	88.61
5	27.76	88.31
6	29.75	88.13

7	31.75	88.06
8	33.75	88.11
9	35.75	88.27
10	37.73	88.55
11	39.69	88.94
12	41.62	89.44
13	43.53	90.05
14	45.39	90.77
15	47.21	91.60
16	48.98	92.53
17	50.69	93.57
18	52.35	94.70
19	53.93	95.92
20	55.44	97.23
21	56.87	98.63
22	58.22	100.11
23	59.48	101.66
24	60.65	103.28
25	61.72	104.97
26	62.70	106.71
27	63.57	108.51
28	64.34	110.36
29	65.00	112.25
30	65.55	114.17
31	65.98	116.12
32	66.31	118.10
33	66.52	120.08
34	66.58	121.45

Circle Center At X = 31.95 ; Y = 122.72 ; and Radius = 34.66

Factor of Safety
 *** 1.629 ***

Slice No.	Width (ft)	Weight (lbs)	Water Force		Tie Force		Earthquake Force		Surcharge Load (lbs)
			Top (lbs)	Bot (lbs)	Norm (lbs)	Tan (lbs)	Hor (lbs)	Ver (lbs)	
1	1.9	70.7	0.0	0.0	0.	0.	0.0	0.0	0.0
2	1.9	204.1	0.0	0.0	0.	0.	0.0	0.0	0.0
3	2.0	317.3	0.0	0.0	0.	0.	0.0	0.0	0.0
4	2.0	407.6	0.0	0.0	0.	0.	0.0	0.0	0.0
5	2.0	473.1	0.0	0.0	0.	0.	0.0	0.0	0.0
6	2.0	512.6	0.0	0.0	0.	0.	0.0	0.0	0.0
7	2.0	525.2	0.0	0.0	0.	0.	0.0	0.0	0.0
8	0.2	65.0	0.0	0.0	0.	0.	0.0	0.0	0.0
9	1.7	944.6	0.0	0.0	0.	0.	0.0	0.0	0.0
10	1.8	1925.7	0.0	0.0	0.	0.	0.0	0.0	0.0
11	0.2	317.1	0.0	0.0	0.	0.	0.0	0.0	0.0
12	2.0	3286.3	0.0	0.0	0.	0.	0.0	0.0	0.0
13	1.9	4169.5	0.0	0.0	0.	0.	0.0	0.0	0.0
14	0.4	916.0	0.0	0.0	0.	0.	0.0	0.0	0.0
15	1.5	4056.8	0.0	0.0	0.	0.	0.0	0.0	0.0
16	0.5	1366.9	0.0	0.0	0.	0.	0.0	0.0	0.0
17	1.4	4104.9	0.0	0.0	0.	0.	0.0	0.0	0.0
18	1.8	5373.4	0.0	0.0	0.	0.	0.0	0.0	0.0
19	1.3	3791.7	0.0	0.0	0.	0.	0.0	0.0	0.0
20	0.5	1411.8	0.0	0.0	0.	0.	0.0	0.0	0.0
21	1.7	4923.5	0.0	0.0	0.	0.	0.0	0.0	0.0
22	1.7	4589.3	0.0	0.0	0.	0.	0.0	0.0	0.0
23	1.6	4234.0	0.0	0.0	0.	0.	0.0	0.0	0.0
24	1.5	3862.7	0.0	0.0	0.	0.	0.0	0.0	0.0
25	1.4	3480.9	0.0	0.0	0.	0.	0.0	0.0	0.0
26	1.3	3094.0	0.0	0.0	0.	0.	0.0	0.0	0.0
27	1.3	2707.9	0.0	0.0	0.	0.	0.0	0.0	0.0
28	1.2	2328.2	0.0	0.0	0.	0.	0.0	0.0	0.0
29	1.1	1960.6	0.0	0.0	0.	0.	0.0	0.0	0.0
30	1.0	1610.5	0.0	0.0	0.	0.	0.0	0.0	0.0

31	0.9	1283.4	0.0	0.0	0.	0.	0.0	0.0	0.0
32	0.8	984.1	0.0	0.0	0.	0.	0.0	0.0	0.0
33	0.7	717.4	0.0	0.0	0.	0.	0.0	0.0	0.0
34	0.5	487.6	0.0	0.0	0.	0.	0.0	0.0	0.0
35	0.4	298.3	0.0	0.0	0.	0.	0.0	0.0	0.0
36	0.3	153.0	0.0	0.0	0.	0.	0.0	0.0	0.0
37	0.2	54.1	0.0	0.0	0.	0.	0.0	0.0	0.0
38	0.1	4.9	0.0	0.0	0.	0.	0.0	0.0	0.0

Failure Surface Specified By 34 Coordinate Points

Point No.	X-Surf (ft)	Y-Surf (ft)
1	20.29	90.19
2	22.18	89.53
3	24.10	88.99
4	26.05	88.56
5	28.03	88.25
6	30.02	88.06
7	32.02	87.98
8	34.02	88.02
9	36.01	88.19
10	37.99	88.47
11	39.95	88.86
12	41.89	89.37
13	43.79	90.00
14	45.64	90.74
15	47.46	91.58
16	49.22	92.54
17	50.91	93.59
18	52.55	94.75
19	54.11	95.99
20	55.60	97.33
21	57.00	98.76
22	58.32	100.26
23	59.54	101.84
24	60.67	103.49
25	61.70	105.21
26	62.63	106.98
27	63.45	108.81
28	64.16	110.68
29	64.75	112.58
30	65.24	114.53
31	65.60	116.49
32	65.85	118.48
33	65.99	120.47
34	65.99	121.37

Circle Center At X = 32.29 ; Y = 121.68 ; and Radius = 33.70

Factor of Safety
 *** 1.630 ***

Failure Surface Specified By 34 Coordinate Points

Point No.	X-Surf (ft)	Y-Surf (ft)
1	21.43	90.21
2	23.33	89.60
3	25.27	89.09
4	27.23	88.70
5	29.21	88.42
6	31.20	88.25
7	33.20	88.19
8	35.20	88.25
9	37.19	88.43
10	39.17	88.72
11	41.13	89.12
12	43.06	89.63
13	44.96	90.25
14	46.82	90.99
15	48.64	91.82

16	50.41	92.76
17	52.12	93.80
18	53.76	94.93
19	55.34	96.16
20	56.85	97.47
21	58.28	98.87
22	59.63	100.35
23	60.89	101.90
24	62.06	103.53
25	63.13	105.21
26	64.11	106.96
27	64.98	108.76
28	65.75	110.60
29	66.42	112.49
30	66.97	114.41
31	67.41	116.36
32	67.74	118.33
33	67.96	120.32
34	68.03	121.65

Circle Center At X = 33.14 ; Y = 123.11 ; and Radius = 34.92

Factor of Safety
 *** 1.630 ***

Failure Surface Specified By 34 Coordinate Points

Point No.	X-Surf (ft)	Y-Surf (ft)
1	21.43	90.21
2	23.31	89.54
3	25.23	88.97
4	27.18	88.52
5	29.15	88.19
6	31.14	87.97
7	33.14	87.87
8	35.14	87.89
9	37.13	88.03
10	39.11	88.29
11	41.08	88.66
12	43.02	89.15
13	44.93	89.75
14	46.79	90.47
15	48.62	91.29
16	50.39	92.22
17	52.10	93.25
18	53.75	94.38
19	55.33	95.61
20	56.83	96.93
21	58.25	98.34
22	59.59	99.83
23	60.84	101.39
24	61.99	103.03
25	63.04	104.73
26	63.99	106.49
27	64.84	108.30
28	65.57	110.16
29	66.20	112.06
30	66.71	113.99
31	67.10	115.95
32	67.38	117.93
33	67.54	119.93
34	67.58	121.59

Circle Center At X = 33.80 ; Y = 121.64 ; and Radius = 33.78

Factor of Safety
 *** 1.635 ***

Failure Surface Specified By 33 Coordinate Points

Point No.	X-Surf (ft)	Y-Surf (ft)
1	22.57	90.24

2	24.50	89.69
3	26.45	89.26
4	28.42	88.94
5	30.41	88.73
6	32.41	88.64
7	34.41	88.66
8	36.40	88.80
9	38.39	89.05
10	40.35	89.41
11	42.30	89.89
12	44.21	90.48
13	46.08	91.17
14	47.91	91.98
15	49.70	92.89
16	51.42	93.89
17	53.09	95.00
18	54.69	96.20
19	56.22	97.49
20	57.67	98.87
21	59.04	100.32
22	60.32	101.86
23	61.52	103.46
24	62.62	105.13
25	63.62	106.86
26	64.52	108.65
27	65.31	110.49
28	66.00	112.36
29	66.58	114.28
30	67.05	116.22
31	67.41	118.19
32	67.65	120.17
33	67.75	121.61

Circle Center At X = 33.03 ; Y = 123.41 ; and Radius = 34.78
 Factor of Safety
 *** 1.643 ***

Failure Surface Specified By 34 Coordinate Points

Point No.	X-Surf (ft)	Y-Surf (ft)
1	23.14	90.25
2	25.07	89.72
3	27.02	89.29
4	29.00	88.97
5	30.99	88.76
6	32.98	88.66
7	34.98	88.67
8	36.98	88.79
9	38.97	89.02
10	40.94	89.37
11	42.89	89.82
12	44.81	90.37
13	46.69	91.04
14	48.54	91.80
15	50.34	92.67
16	52.10	93.63
17	53.79	94.69
18	55.43	95.85
19	56.99	97.09
20	58.49	98.41
21	59.91	99.82
22	61.25	101.30
23	62.51	102.86
24	63.68	104.48
25	64.76	106.17
26	65.74	107.91
27	66.63	109.70
28	67.41	111.54

29	68.09	113.42
30	68.67	115.34
31	69.14	117.28
32	69.50	119.25
33	69.75	121.23
34	69.80	121.89

Circle Center At X = 33.79 ; Y = 124.78 ; and Radius = 36.13
 Factor of Safety
 *** 1.646 ***

Failure Surface Specified By 33 Coordinate Points

Point No.	X-Surf (ft)	Y-Surf (ft)
1	23.43	90.26
2	25.34	89.66
3	27.28	89.19
4	29.25	88.83
5	31.23	88.58
6	33.23	88.46
7	35.23	88.46
8	37.23	88.58
9	39.21	88.82
10	41.18	89.17
11	43.12	89.65
12	45.03	90.24
13	46.90	90.95
14	48.73	91.76
15	50.50	92.69
16	52.22	93.72
17	53.87	94.85
18	55.45	96.08
19	56.95	97.40
20	58.37	98.81
21	59.70	100.30
22	60.94	101.87
23	62.08	103.51
24	63.12	105.22
25	64.06	106.98
26	64.89	108.80
27	65.61	110.67
28	66.21	112.57
29	66.70	114.51
30	67.08	116.48
31	67.33	118.46
32	67.46	120.46
33	67.47	121.57

Circle Center At X = 34.26 ; Y = 121.67 ; and Radius = 33.22
 Factor of Safety
 *** 1.647 ***

Failure Surface Specified By 35 Coordinate Points

Point No.	X-Surf (ft)	Y-Surf (ft)
1	20.86	90.20
2	22.80	89.74
3	24.77	89.38
4	26.75	89.12
5	28.75	88.96
6	30.75	88.89
7	32.75	88.92
8	34.74	89.05
9	36.73	89.29
10	38.70	89.61
11	40.66	90.04
12	42.59	90.56
13	44.49	91.18
14	46.36	91.89
15	48.19	92.69

16	49.98	93.58
17	51.73	94.56
18	53.42	95.62
19	55.06	96.77
20	56.64	97.99
21	58.16	99.30
22	59.61	100.67
23	60.99	102.12
24	62.30	103.63
25	63.53	105.21
26	64.68	106.84
27	65.75	108.53
28	66.74	110.27
29	67.64	112.06
30	68.44	113.89
31	69.16	115.76
32	69.79	117.66
33	70.32	119.58
34	70.75	121.54
35	70.83	122.03

Circle Center At X = 31.08 ; Y = 129.31 ; and Radius = 40.43

Factor of Safety
 *** 1.648 ***

Failure Surface Specified By 33 Coordinate Points

Point No.	X-Surf (ft)	Y-Surf (ft)
1	22.29	90.23
2	24.22	89.72
3	26.18	89.32
4	28.16	89.04
5	30.15	88.86
6	32.15	88.80
7	34.15	88.86
8	36.14	89.03
9	38.12	89.31
10	40.08	89.70
11	42.02	90.20
12	43.92	90.81
13	45.79	91.53
14	47.61	92.36
15	49.38	93.29
16	51.10	94.31
17	52.76	95.44
18	54.34	96.65
19	55.86	97.95
20	57.30	99.34
21	58.66	100.81
22	59.93	102.35
23	61.12	103.96
24	62.21	105.64
25	63.20	107.38
26	64.09	109.17
27	64.88	111.00
28	65.56	112.88
29	66.14	114.80
30	66.61	116.74
31	66.96	118.71
32	67.20	120.70
33	67.26	121.54

Circle Center At X = 32.21 ; Y = 123.95 ; and Radius = 35.14

Factor of Safety
 *** 1.649 ***

Failure Surface Specified By 36 Coordinate Points

Point No.	X-Surf (ft)	Y-Surf (ft)
1	20.29	90.19

2	22.24	89.74
3	24.20	89.38
4	26.18	89.11
5	28.18	88.93
6	30.17	88.84
7	32.17	88.85
8	34.17	88.94
9	36.16	89.13
10	38.14	89.40
11	40.11	89.77
12	42.06	90.22
13	43.98	90.76
14	45.88	91.39
15	47.75	92.11
16	49.58	92.91
17	51.38	93.79
18	53.13	94.76
19	54.84	95.80
20	56.49	96.92
21	58.10	98.11
22	59.65	99.38
23	61.14	100.71
24	62.57	102.11
25	63.93	103.58
26	65.22	105.10
27	66.45	106.68
28	67.60	108.32
29	68.67	110.01
30	69.67	111.74
31	70.58	113.52
32	71.42	115.34
33	72.17	117.19
34	72.83	119.07
35	73.41	120.99
36	73.78	122.43

Circle Center At X = 31.11 ; Y = 132.73 ; and Radius = 43.89
 Factor of Safety
 *** 1.650 ***
 **** END OF GSTABL7 OUTPUT ****

Section C-C

040596-001 TORREY PINES ROAD SECTION C-C' existing topo

C:\KEN\SLOPES~1\040596~1\REVISE~1\IC-C\CC_RUN3.PL2 Run By: Username 4/2/02 11:14AM

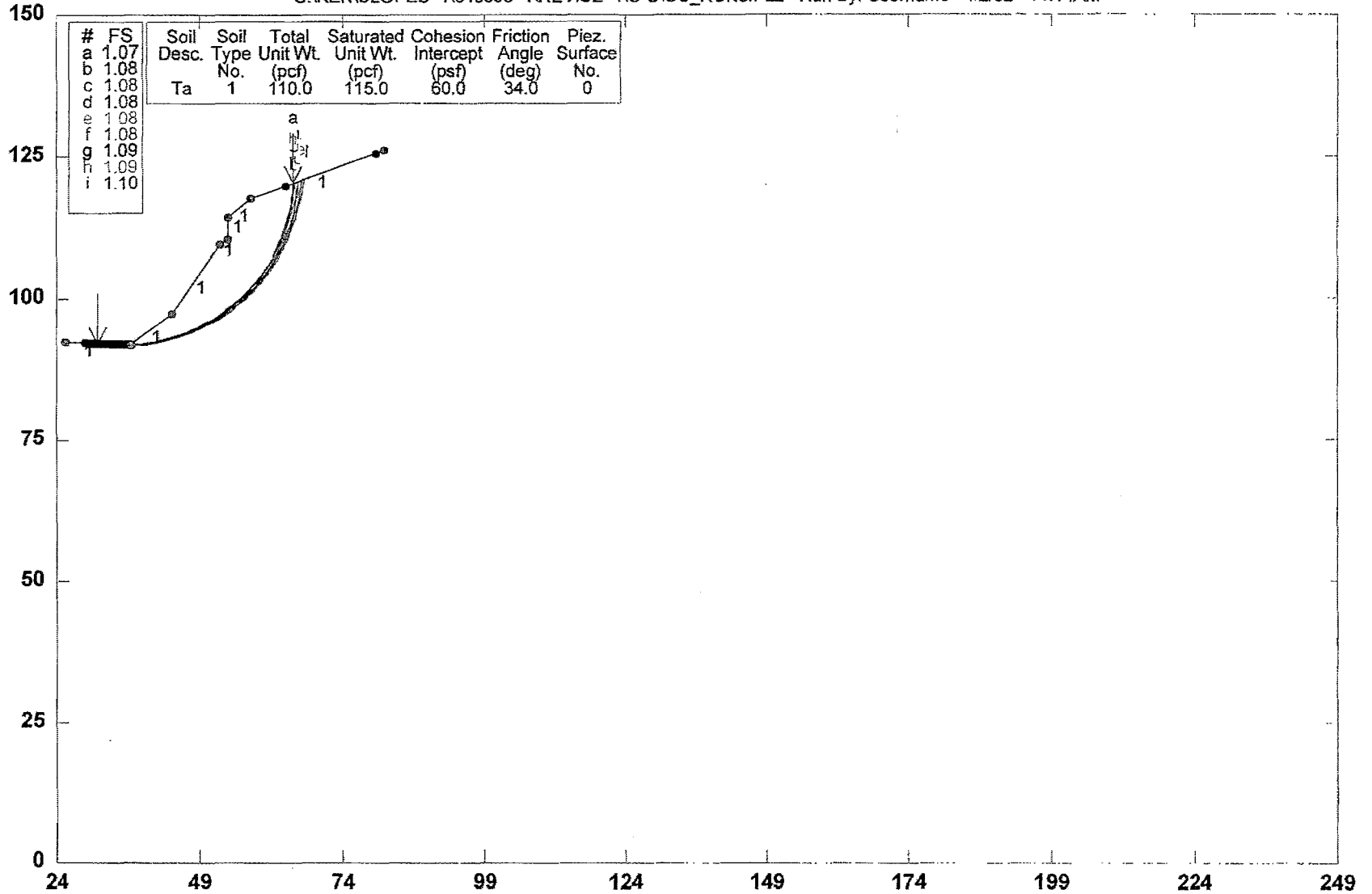

GSTABL7 FSmin=1.07

Safety Factors Are Calculated By The Modified Bishop Method

STED



040596-001 TORREY PINES ROAD SECTION C-C'/temp cut for soil nails

C:\KENSLOPES~1\040596~1\REVISE~1\C-C\CC_TEMP1.PL2 Run By: Username 4/2/02 11:16AM

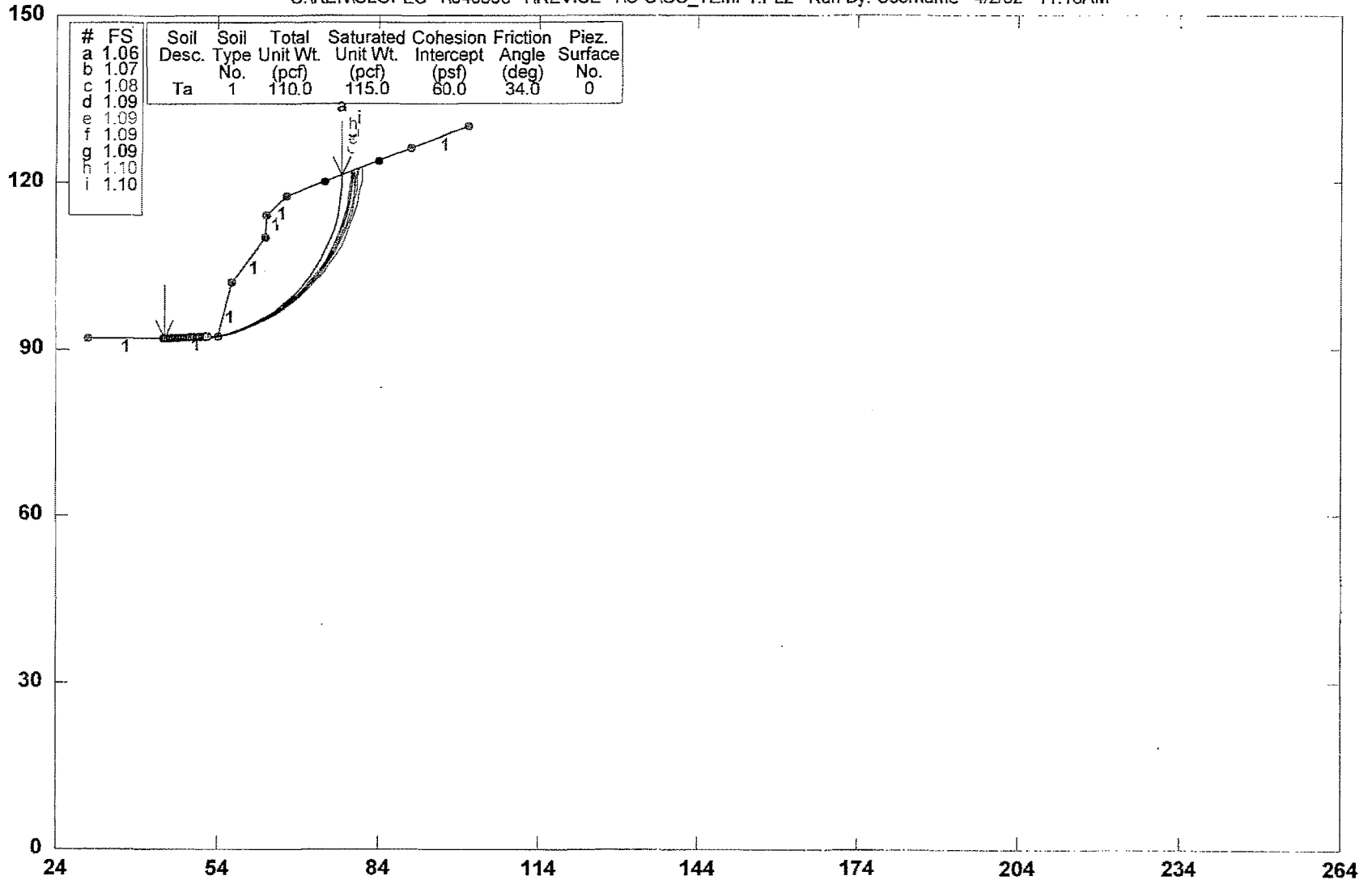

GSTABL7 FSmin=1.06

Safety Factors Are Calculated By The Modified Bishop Method

STED



040596-001 TORREY PINES ROAD SECTION C-C'/proposed soil nail

C:\KEN\SLOPES~1\040596~1\REVISE~1\C-C\ICC_PRO1.PL2 Run By: Username 4/2/02 11:17AM

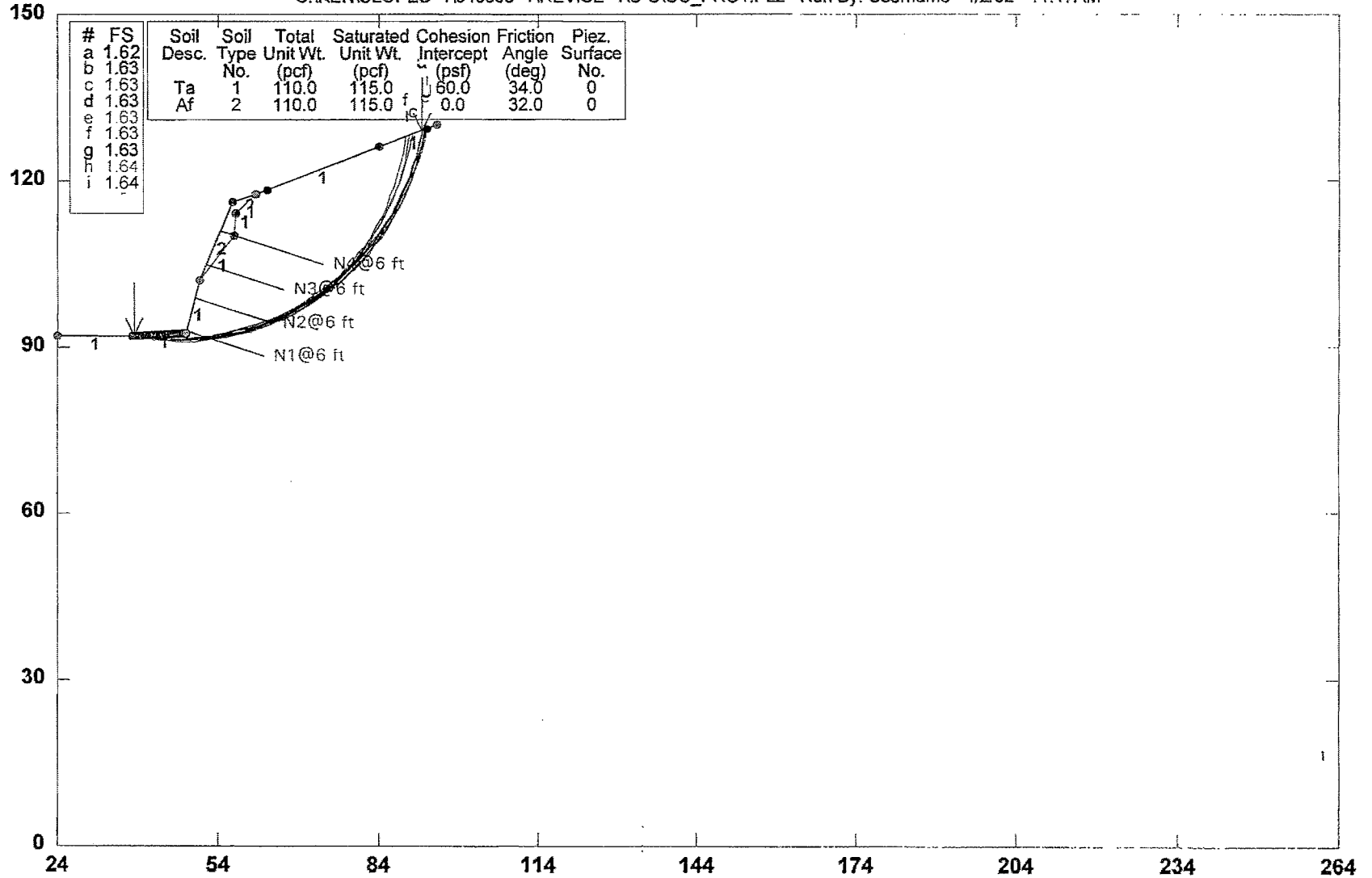

GSTABL7 v.2 FSmin=1.62

Safety Factors Are Calculated By The Modified Bishop Method

STED



040596-001 TORREY PINES ROAD SECTION C-C'/soil nail w/seismic

C:\KENSLOPES~1\040596~1\REVISE~1\C-C\CC_PRO3.PL2 Run By: Username 4/2/02 11:23AM

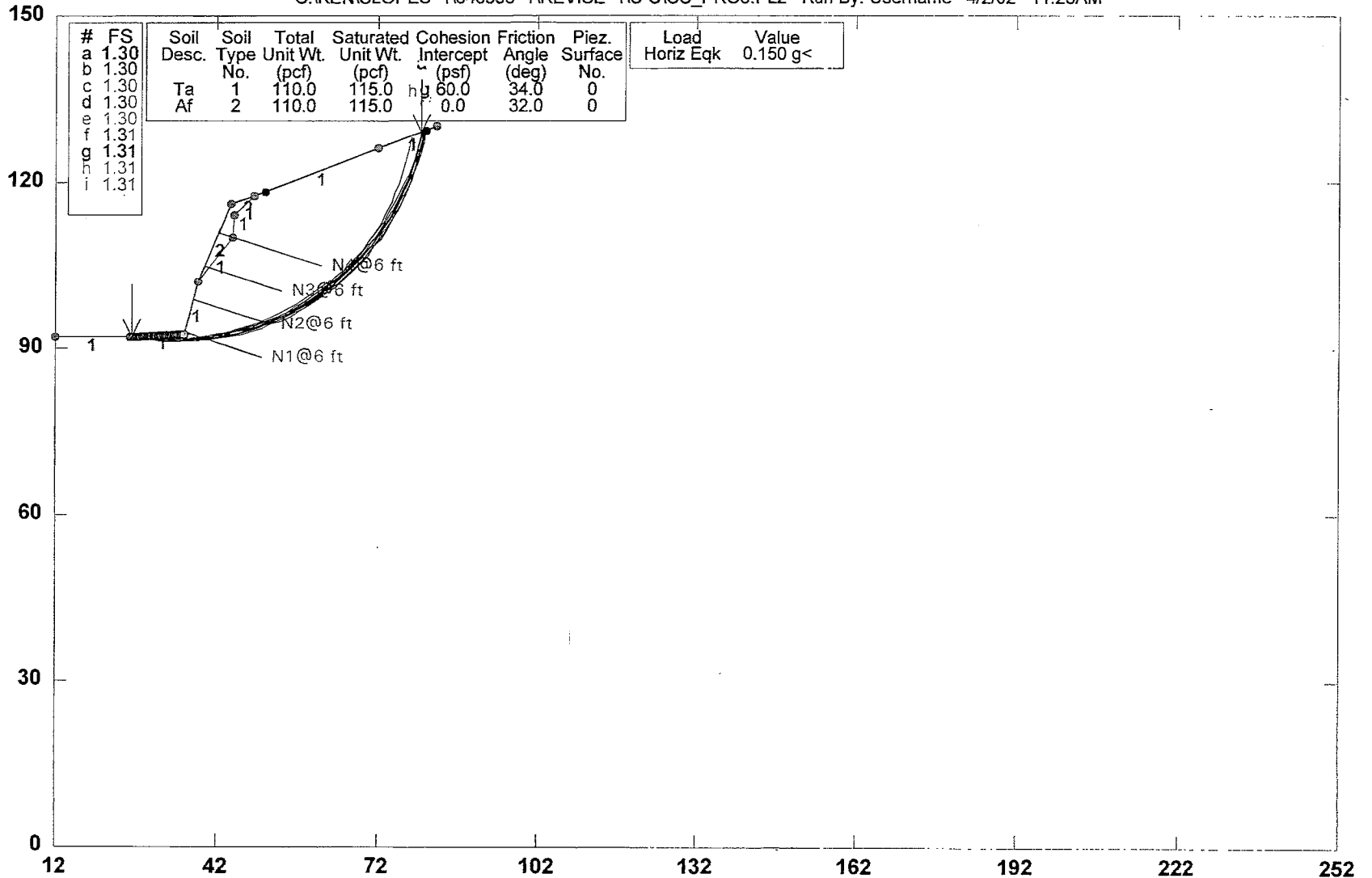

GSTABL7 v.2 FSmin=1.30

Safety Factors Are Calculated By The Modified Bishop Method

STED



040596-001 TORREY PINES ROAD SECTION C-C'/soil nail w/seismic

C:\KEN\SLOPES~1\040596~1\REVISE~1\C-C'_PRO3.PL2 Run By: Username 4/2/02 11:22AM

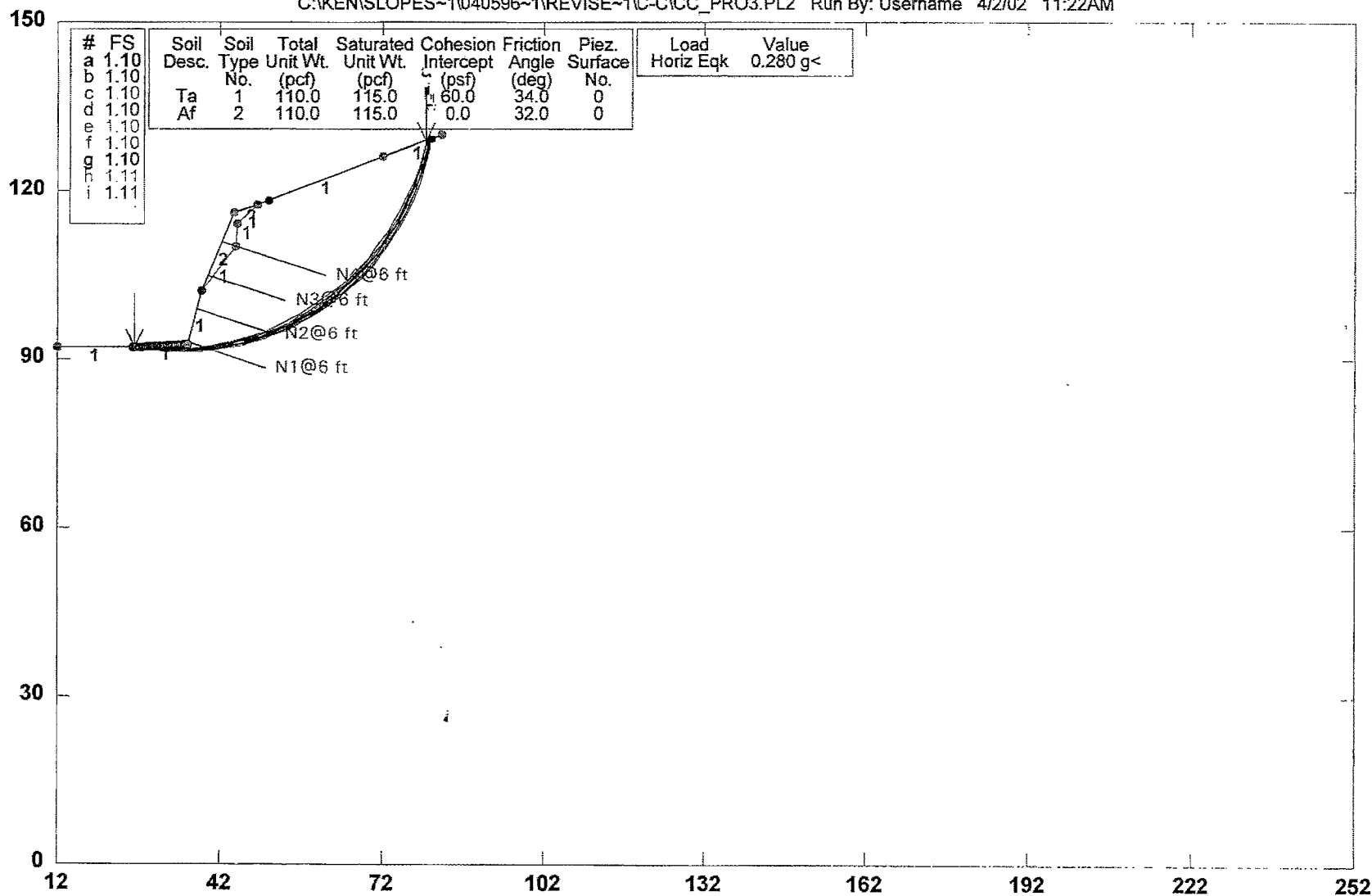

GSTABL7 v.2 FSmin=1.10

Safety Factors Are Calculated By The Modified Bishop Method

STED

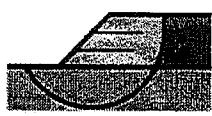

*** GSTABL7 ***

** GSTABL7 by Garry H. Gregory, P.E. **

** Original Version 1.0, January 1996; Current Version 2.002, December 2001 **
 (All Rights Reserved-Unauthorized Use Prohibited)

SLOPE STABILITY ANALYSIS SYSTEM

Modified Bishop, Simplified Janbu, or GLE Method of Slices.
 (Includes Spencer & Morgenstern-Price Type Analysis)
 Including Pier/Pile, Reinforcement, Soil Nail, Tieback,
 Nonlinear Undrained Shear Strength, Curved Phi Envelope,
 Anisotropic Soil, Fiber-Reinforced Soil, Boundary Loads, Water
 Surfaces, Pseudo-Static Earthquake, and Applied Force Options.

Analysis Run Date: 4/2/02
 Time of Run: 11:17AM
 Run By: Username
 Input Data Filename: C:cc_prol.
 Output Filename: C:cc_prol.OUT
 Unit System: English
 Plotted Output Filename: C:cc_prol.PLT
 PROBLEM DESCRIPTION: 040596-001 TORREY PINES ROAD
 SECTION C-C'/proposed soil nail

BOUNDARY COORDINATES

Note: User origin value specified.
 Add 24.00 to X-values and 0.00 to Y-values listed.

7 Top Boundaries
 10 Total Boundaries

Boundary No.	X-Left (ft)	Y-Left (ft)	X-Right (ft)	Y-Right (ft)	Soil Type Below End
1	0.00	92.00	14.00	92.00	1
2	14.00	92.00	24.00	92.50	1
3	24.00	92.50	26.50	102.00	1
4	26.50	102.00	32.50	116.00	2
5	32.50	116.00	37.00	117.50	2
6	37.00	117.50	60.00	126.00	1
7	60.00	126.00	71.00	130.00	1
8	26.50	102.00	33.00	110.00	1
9	33.00	110.00	33.10	114.00	1
10	33.10	114.00	37.00	117.50	1

Default Y-Origin = 0.00(ft)

ISOTROPIC SOIL PARAMETERS

2 Type(s) of Soil

Soil Type No.	Total Unit Wt. (pcf)	Saturated Unit Wt. (pcf)	Cohesion Intercept (psf)	Friction Angle (deg)	Pore Pressure Param. (psf)	Pressure Constant (psf)	Piez. Surface No.
1	110.0	115.0	60.0	34.0	0.00	0.0	0
2	110.0	115.0	0.0	32.0	0.00	0.0	0

SOIL NAIL LOAD(S)

4 SOIL NAIL LOAD(S) SPECIFIED

Nail No.	X-Pos (ft)	Y-Pos (ft)	Nail Dia (in)	Tendon Dia (in)	Spacing (ft)	Inclin. (deg)	Length (ft)
1	24.13	93.00	6.0	1.0	6.00	18.00	15.00
2	25.71	99.00	6.0	1.0	6.00	18.00	15.00
3	27.79	105.00	6.0	1.0	6.00	18.00	15.00
4	30.36	111.00	6.0	1.0	6.00	18.00	20.00

SOIL NAIL LOAD DATA

Soil Nail No. 1 3 Load Points Apply to This Nail

Load Diagram Type = 2

POINT NO.	X-COORD. (ft)	Y-COORD. (ft)	FORCE (lbs)
1	24.13	93.00	6283.19
2	35.38	89.53	6283.19
3	38.40	88.36	0.00

Allowable Pullout Stress = 20000.0(psf)
 Allowable Tendon Stress = 48000.0(psi)
 Allowable Nail Head Load = 48000.0(lbs)

Soil Nail No. 2 3 Load Points Apply to This Nail

Load Diagram Type = 2

POINT NO.	X-COORD. (ft)	Y-COORD. (ft)	FORCE (lbs)
1	25.71	99.00	6283.19
2	36.88	95.55	6283.19
3	39.98	94.36	0.00

Allowable Pullout Stress = 20000.0(psf)
 Allowable Tendon Stress = 48000.0(psi)
 Allowable Nail Head Load = 48000.0(lbs)

Soil Nail No. 3 3 Load Points Apply to This Nail

Load Diagram Type = 2

POINT NO.	X-COORD. (ft)	Y-COORD. (ft)	FORCE (lbs)
1	27.79	105.00	6283.19
2	38.85	101.58	6283.19
3	42.05	100.36	0.00

Allowable Pullout Stress = 20000.0(psf)
 Allowable Tendon Stress = 48000.0(psi)
 Allowable Nail Head Load = 48000.0(lbs)

Soil Nail No. 4 3 Load Points Apply to This Nail

Load Diagram Type = 2

POINT NO.	X-COORD. (ft)	Y-COORD. (ft)	FORCE (lbs)
1	30.36	111.00	6283.19
2	45.82	106.22	6283.19
3	49.38	104.82	0.00

Allowable Pullout Stress = 20000.0(psf)
 Allowable Tendon Stress = 48000.0(psi)
 Allowable Nail Head Load = 48000.0(lbs)

NOTE - An Equivalent Line Load Is Calculated For Each Row Of Soil Nails
 Assuming A Uniform Distribution Of Load Horizontally Between
 Individual Nails.

A Critical Failure Surface Searching Method, Using A Random
 Technique For Generating Circular Surfaces, Has Been Specified.
 500 Trial Surfaces Have Been Generated.

10 Surface(s) Initiate(s) From Each Of 50 Points Equally Spaced
 Along The Ground Surface Between X = 14.00(ft)
 and X = 24.00(ft)
 Each Surface Terminates Between X = 39.00(ft)
 and X = 69.00(ft)

Unless Further Limitations Were Imposed, The Minimum Elevation
 At Which A Surface Extends Is Y = 0.00(ft)

2.00(ft) Line Segments Define Each Trial Failure Surface.
 Following Are Displayed The Ten Most Critical Of The Trial

Failure Surfaces Evaluated. They Are
 Ordered - Most Critical First.

* * Safety Factors Are Calculated By The Modified Bishop Method * *

Total Number of Trial Surfaces Evaluated = 500

Statistical Data On All Valid FS Values:

FS Max = 4.013 FS Min = 1.624 FS Ave = 1.759

Standard Deviation = 0.126 Coefficient of Variation = 7.16 %

Failure Surface Specified By 38 Coordinate Points

Point No.	X-Surf (ft)	Y-Surf (ft)
1	14.20	92.01
2	16.18	91.70
3	18.17	91.47
4	20.16	91.33
5	22.16	91.28
6	24.16	91.31
7	26.16	91.42
8	28.15	91.63
9	30.13	91.91
10	32.09	92.29
11	34.04	92.74
12	35.96	93.28
13	37.87	93.90
14	39.74	94.61

15	41.58	95.39
16	43.38	96.25
17	45.15	97.19
18	46.87	98.20
19	48.55	99.29
20	50.19	100.45
21	51.77	101.67
22	53.29	102.96
23	54.76	104.32
24	56.17	105.74
25	57.52	107.22
26	58.80	108.75
27	60.01	110.34
28	61.16	111.98
29	62.23	113.67
30	63.23	115.40
31	64.16	117.17
32	65.01	118.98
33	65.78	120.83
34	66.47	122.71
35	67.08	124.61
36	67.60	126.54
37	68.05	128.49
38	68.13	128.96

Circle Center At X = 22.45 ; Y = 137.81 ; and Radius = 46.53

Factor of Safety
 *** 1.624 ***

Slice No.	Width (ft)	Weight (lbs)	Individual data on the 44 slices				Earthquake		
			Water Force		Tie Force		Force		Surcharge Load (lbs)
			Top (lbs)	Bot (lbs)	Norm (lbs)	Tan (lbs)	Hor (lbs)	Ver (lbs)	
1	2.0	44.6	0.0	0.0	0.	0.	0.0	0.0	0.0
2	2.0	125.3	0.0	0.0	0.	0.	0.0	0.0	0.0
3	2.0	188.0	0.0	0.0	0.	0.	0.0	0.0	0.0
4	2.0	231.9	0.0	0.0	0.	0.	0.0	0.0	0.0
5	1.8	235.4	0.0	0.0	0.	0.	0.0	0.0	0.0
6	0.2	26.6	0.0	0.0	0.	0.	0.0	0.0	0.0
7	2.0	1217.0	0.0	0.0	0.	0.	0.0	0.0	0.0
8	0.3	372.9	0.0	0.0	0.	0.	0.0	0.0	0.0
9	1.6	2243.8	0.0	0.0	0.	0.	0.0	0.0	0.0
10	2.0	3567.0	0.0	0.0	0.	0.	0.0	0.0	0.0
11	2.0	4464.7	0.0	0.0	0.	0.	0.0	0.0	0.0
12	0.4	1041.1	0.0	0.0	0.	0.	0.0	0.0	0.0
13	0.5	1300.4	0.0	0.0	0.	0.	0.0	0.0	0.0
14	0.1	260.4	0.0	0.0	0.	0.	0.0	0.0	0.0
15	0.9	2450.6	0.0	0.0	0.	0.	0.0	0.0	0.0
16	1.9	5046.4	0.0	0.0	0.	0.	0.0	0.0	0.0
17	1.0	2718.6	0.0	0.0	0.	0.	0.0	0.0	0.0
18	0.9	2275.7	0.0	0.0	0.	0.	0.0	0.0	0.0
19	1.9	4924.6	0.0	0.0	0.	0.	0.0	0.0	0.0
20	1.8	4829.1	0.0	0.0	0.	0.	0.0	0.0	0.0
21	1.8	4706.9	0.0	0.0	0.	0.	0.0	0.0	0.0
22	1.8	4559.6	0.0	0.0	0.	0.	0.0	0.0	0.0
23	1.7	4388.7	0.0	0.0	0.	0.	0.0	0.0	0.0
24	1.7	4196.2	0.0	0.0	0.	0.	0.0	0.0	0.0
25	1.6	3984.3	0.0	0.0	0.	0.	0.0	0.0	0.0
26	1.6	3755.2	0.0	0.0	0.	0.	0.0	0.0	0.0
27	1.5	3511.4	0.0	0.0	0.	0.	0.0	0.0	0.0
28	1.5	3255.6	0.0	0.0	0.	0.	0.0	0.0	0.0
29	1.4	2990.6	0.0	0.0	0.	0.	0.0	0.0	0.0
30	1.3	2719.3	0.0	0.0	0.	0.	0.0	0.0	0.0
31	1.3	2444.6	0.0	0.0	0.	0.	0.0	0.0	0.0
32	1.2	2146.4	0.0	0.0	0.	0.	0.0	0.0	0.0
33	0.0	23.1	0.0	0.0	0.	0.	0.0	0.0	0.0
34	1.1	1896.8	0.0	0.0	0.	0.	0.0	0.0	0.0

35	1.1	1629.7	0.0	0.0	0.	0.	0.0	0.0	0.0
36	1.0	1371.6	0.0	0.0	0.	0.	0.0	0.0	0.0
37	0.9	1125.6	0.0	0.0	0.	0.	0.0	0.0	0.0
38	0.8	894.8	0.0	0.0	0.	0.	0.0	0.0	0.0
39	0.8	682.0	0.0	0.0	0.	0.	0.0	0.0	0.0
40	0.7	490.0	0.0	0.0	0.	0.	0.0	0.0	0.0
41	0.6	321.5	0.0	0.0	0.	0.	0.0	0.0	0.0
42	0.5	178.9	0.0	0.0	0.	0.	0.0	0.0	0.0
43	0.4	64.6	0.0	0.0	0.	0.	0.0	0.0	0.0
44	0.1	2.0	0.0	0.0	0.	0.	0.0	0.0	0.0

Failure Surface Specified By 37 Coordinate Points

Point No.	X-Surf (ft)	Y-Surf (ft)
1	14.20	92.01
2	16.16	91.61
3	18.14	91.31
4	20.13	91.09
5	22.13	90.98
6	24.13	90.95
7	26.12	91.03
8	28.12	91.19
9	30.10	91.45
10	32.07	91.80
11	34.02	92.25
12	35.95	92.78
13	37.85	93.41
14	39.71	94.13
15	41.54	94.93
16	43.34	95.82
17	45.08	96.79
18	46.78	97.85
19	48.43	98.98
20	50.02	100.19
21	51.56	101.47
22	53.03	102.83
23	54.44	104.25
24	55.77	105.74
25	57.04	107.28
26	58.23	108.89
27	59.34	110.55
28	60.38	112.26
29	61.33	114.02
30	62.20	115.82
31	62.98	117.66
32	63.68	119.54
33	64.28	121.45
34	64.80	123.38
35	65.22	125.33
36	65.55	127.31
37	65.64	128.05

Circle Center At X = 23.62 ; Y = 133.31 ; and Radius = 42.36

Factor of Safety

*** 1.625 ***

Failure Surface Specified By 37 Coordinate Points

Point No.	X-Surf (ft)	Y-Surf (ft)
1	14.41	92.02
2	16.38	91.68
3	18.36	91.43
4	20.36	91.27
5	22.36	91.21
6	24.36	91.23
7	26.35	91.34
8	28.34	91.55
9	30.32	91.84
10	32.28	92.23

11	34.23	92.70
12	36.15	93.26
13	38.04	93.91
14	39.90	94.65
15	41.72	95.47
16	43.51	96.37
17	45.25	97.35
18	46.95	98.41
19	48.59	99.54
20	50.19	100.75
21	51.72	102.03
22	53.20	103.38
23	54.61	104.79
24	55.96	106.27
25	57.24	107.81
26	58.45	109.40
27	59.58	111.05
28	60.64	112.75
29	61.62	114.49
30	62.52	116.28
31	63.34	118.10
32	64.07	119.97
33	64.72	121.86
34	65.28	123.78
35	65.75	125.72
36	66.13	127.68
37	66.22	128.26

Circle Center At X = 22.84 ; Y = 135.13 ; and Radius = 43.93

Factor of Safety
 *** 1.626 ***

Failure Surface Specified By 38 Coordinate Points

Point No.	X-Surf (ft)	Y-Surf (ft)
1	15.02	92.05
2	17.00	91.75
3	18.99	91.53
4	20.98	91.39
5	22.98	91.35
6	24.98	91.38
7	26.98	91.51
8	28.97	91.72
9	30.94	92.01
10	32.91	92.39
11	34.85	92.86
12	36.78	93.40
13	38.67	94.03
14	40.54	94.74
15	42.38	95.53
16	44.18	96.40
17	45.95	97.35
18	47.67	98.37
19	49.34	99.46
20	50.97	100.63
21	52.54	101.86
22	54.06	103.16
23	55.52	104.52
24	56.93	105.95
25	58.27	107.43
26	59.54	108.97
27	60.75	110.57
28	61.89	112.21
29	62.96	113.90
30	63.95	115.64
31	64.87	117.42
32	65.71	119.23
33	66.47	121.08

34	67.15	122.96
35	67.75	124.87
36	68.26	126.80
37	68.70	128.75
38	68.77	129.19

Circle Center At X = 23.09 ; Y = 137.84 ; and Radius = 46.49
 Factor of Safety
 *** 1.627 ***

Failure Surface Specified By 38 Coordinate Points

Point No.	X-Surf (ft)	Y-Surf (ft)
1	14.61	92.03
2	16.58	91.69
3	18.57	91.43
4	20.56	91.25
5	22.56	91.17
6	24.56	91.17
7	26.55	91.26
8	28.55	91.44
9	30.53	91.70
10	32.50	92.05
11	34.45	92.48
12	36.38	93.00
13	38.29	93.61
14	40.17	94.29
15	42.01	95.06
16	43.83	95.91
17	45.60	96.83
18	47.33	97.83
19	49.02	98.91
20	50.65	100.06
21	52.24	101.28
22	53.77	102.57
23	55.24	103.92
24	56.66	105.33
25	58.00	106.81
26	59.29	108.34
27	60.50	109.93
28	61.65	111.57
29	62.72	113.26
30	63.72	114.99
31	64.64	116.77
32	65.49	118.58
33	66.25	120.43
34	66.93	122.31
35	67.53	124.22
36	68.05	126.15
37	68.48	128.10
38	68.66	129.15

Circle Center At X = 23.51 ; Y = 136.98 ; and Radius = 45.82
 Factor of Safety
 *** 1.628 ***

Failure Surface Specified By 36 Coordinate Points

Point No.	X-Surf (ft)	Y-Surf (ft)
1	15.02	92.05
2	16.99	91.70
3	18.97	91.43
4	20.96	91.27
5	22.96	91.20
6	24.96	91.22
7	26.96	91.34
8	28.95	91.56
9	30.92	91.87
10	32.88	92.27
11	34.82	92.77

12	36.73	93.36
13	38.61	94.04
14	40.46	94.81
15	42.27	95.66
16	44.03	96.60
17	45.75	97.63
18	47.42	98.73
19	49.03	99.92
20	50.58	101.18
21	52.07	102.51
22	53.50	103.91
23	54.86	105.38
24	56.14	106.91
25	57.35	108.50
26	58.49	110.15
27	59.54	111.85
28	60.51	113.60
29	61.40	115.39
30	62.20	117.22
31	62.91	119.09
32	63.54	120.99
33	64.07	122.92
34	64.50	124.87
35	64.85	126.84
36	64.97	127.81

Circle Center At X = 23.45 ; Y = 133.04 ; and Radius = 41.85

Factor of Safety
 *** 1.633 ***

Failure Surface Specified By 37 Coordinate Points

Point No.	X-Surf (ft)	Y-Surf (ft)
1	15.63	92.08
2	17.61	91.79
3	19.60	91.59
4	21.60	91.47
5	23.60	91.44
6	25.60	91.50
7	27.59	91.64
8	29.58	91.86
9	31.55	92.18
10	33.52	92.57
11	35.46	93.06
12	37.37	93.62
13	39.27	94.27
14	41.13	94.99
15	42.96	95.80
16	44.75	96.69
17	46.51	97.65
18	48.22	98.69
19	49.88	99.80
20	51.50	100.98
21	53.06	102.22
22	54.57	103.54
23	56.02	104.92
24	57.40	106.36
25	58.73	107.85
26	59.99	109.41
27	61.18	111.02
28	62.30	112.67
29	63.35	114.37
30	64.32	116.12
31	65.22	117.91
32	66.04	119.73
33	66.78	121.59
34	67.44	123.48
35	68.02	125.39

36 68.51 127.33
 37 68.91 129.24
 Circle Center At X = 23.32 ; Y = 137.84 ; and Radius = 46.40
 Factor of Safety
 *** 1.633 ***

Failure Surface Specified By 38 Coordinate Points

Point No.	X-Surf (ft)	Y-Surf (ft)
1	14.00	92.00
2	15.98	91.75
3	17.98	91.57
4	19.97	91.48
5	21.97	91.48
6	23.97	91.55
7	25.97	91.71
8	27.95	91.94
9	29.93	92.26
10	31.89	92.66
11	33.83	93.14
12	35.75	93.70
13	37.64	94.34
14	39.51	95.05
15	41.35	95.85
16	43.15	96.71
17	44.92	97.65
18	46.64	98.66
19	48.33	99.74
20	49.97	100.89
21	51.55	102.10
22	53.09	103.38
23	54.58	104.72
24	56.00	106.12
25	57.37	107.58
26	58.68	109.10
27	59.92	110.66
28	61.10	112.28
29	62.22	113.94
30	63.26	115.65
31	64.23	117.39
32	65.13	119.18
33	65.96	121.00
34	66.70	122.86
35	67.38	124.74
36	67.97	126.65
37	68.49	128.58
38	68.61	129.13

Circle Center At X = 21.17 ; Y = 140.18 ; and Radius = 48.71
 Factor of Safety
 *** 1.636 ***

Failure Surface Specified By 38 Coordinate Points

Point No.	X-Surf (ft)	Y-Surf (ft)
1	14.82	92.04
2	16.80	91.80
3	18.80	91.64
4	20.79	91.56
5	22.79	91.56
6	24.79	91.65
7	26.78	91.82
8	28.77	92.07
9	30.74	92.40
10	32.70	92.81
11	34.64	93.30
12	36.55	93.88
13	38.44	94.53
14	40.31	95.26

15	42.14	96.06
16	43.93	96.94
17	45.69	97.89
18	47.41	98.92
19	49.08	100.01
20	50.71	101.18
21	52.29	102.41
22	53.81	103.70
23	55.29	105.05
24	56.70	106.47
25	58.06	107.94
26	59.35	109.46
27	60.58	111.04
28	61.74	112.67
29	62.84	114.34
30	63.86	116.06
31	64.81	117.82
32	65.69	119.61
33	66.50	121.44
34	67.23	123.31
35	67.88	125.20
36	68.45	127.11
37	68.95	129.05
38	68.99	129.27

Circle Center At X = 21.71 ; Y = 140.05 ; and Radius = 48.50

Factor of Safety
 *** 1.638 ***

Failure Surface Specified By 37 Coordinate Points

Point No.	X-Surf (ft)	Y-Surf (ft)
1	15.43	92.07
2	17.41	91.82
3	19.41	91.65
4	21.40	91.56
5	23.40	91.56
6	25.40	91.65
7	27.40	91.82
8	29.38	92.07
9	31.35	92.41
10	33.31	92.83
11	35.24	93.33
12	37.15	93.91
13	39.04	94.58
14	40.90	95.32
15	42.72	96.14
16	44.51	97.04
17	46.26	98.01
18	47.96	99.06
19	49.62	100.18
20	51.23	101.36
21	52.79	102.61
22	54.29	103.93
23	55.74	105.31
24	57.13	106.75
25	58.46	108.25
26	59.72	109.80
27	60.91	111.41
28	62.04	113.06
29	63.09	114.76
30	64.07	116.50
31	64.98	118.28
32	65.81	120.10
33	66.56	121.96
34	67.24	123.84
35	67.83	125.75
36	68.34	127.68

37 68.67 129.15
Circle Center At X = 22.40 ; Y = 138.83 ; and Radius = 47.27
Factor of Safety
*** 1.639 ***
**** END OF GSTABL7 OUTPUT ****

1.0 General

1.1 Intent

These General Earthwork and Grading Specifications are for the grading and earthwork shown on the approved grading plan(s) and/or indicated in the geotechnical report(s). These Specifications are a part of the recommendations contained in the geotechnical report(s). In case of conflict, the specific recommendations in the geotechnical report shall supersede these more general Specifications. Observations of the earthwork by the project Geotechnical Consultant during the course of grading may result in new or revised recommendations that could supersede these specifications or the recommendations in the geotechnical report(s).

1.2 The Geotechnical Consultant of Record

Prior to commencement of work, the owner shall employ the Geotechnical Consultant of Record (Geotechnical Consultant). The Geotechnical Consultants shall be responsible for reviewing the approved geotechnical report(s) and accepting the adequacy of the preliminary geotechnical findings, conclusions, and recommendations prior to the commencement of the grading.

Prior to commencement of grading, the Geotechnical Consultant shall review the "work plan" prepared by the Earthwork Contractor (Contractor) and schedule sufficient personnel to perform the appropriate level of observation, mapping, and compaction testing.

During the grading and earthwork operations, the Geotechnical Consultant shall observe, map, and document the subsurface exposures to verify the geotechnical design assumptions. If the observed conditions are found to be significantly different than the interpreted assumptions during the design phase, the Geotechnical Consultant shall inform the owner, recommend appropriate changes in design to accommodate the observed conditions, and notify the review agency where required. Subsurface areas to be geotechnically observed, mapped, elevations recorded, and/or tested include natural ground after it has been cleared for receiving fill but before fill is placed, bottoms of all "remedial removal" areas, all key bottoms, and benches made on sloping ground to receive fill.

The Geotechnical Consultant shall observe the moisture-conditioning and processing of the subgrade and fill materials and perform relative compaction testing of fill to determine the attained level of compaction. The Geotechnical Consultant shall provide the test results to the owner and the Contractor on a routine and frequent basis.

1.3 The Earthwork Contractor

The Earthwork Contractor (Contractor) shall be qualified, experienced, and knowledgeable in earthwork logistics, preparation and processing of ground to receive fill, moisture-conditioning and processing of fill, and compacting fill. The Contractor shall review and accept the plans, geotechnical report(s), and these Specifications prior to commencement of grading. The Contractor shall be solely responsible for performing the grading in accordance with the plans and specifications.

The Contractor shall prepare and submit to the owner and the Geotechnical Consultant a work plan that indicates the sequence of earthwork grading, the number of "spreads" of work and the estimated quantities of daily earthwork contemplated for the site prior to commencement of grading. The Contractor shall inform the owner and the Geotechnical Consultant of changes in work schedules and updates to the work plan at least 24 hours in advance of such changes so that appropriate observations and tests can be planned and accomplished. The Contractor shall not assume that the Geotechnical Consultant is aware of all grading operations.

The Contractor shall have the sole responsibility to provide adequate equipment and methods to accomplish the earthwork in accordance with the applicable grading codes and agency ordinances, these Specifications, and the recommendations in the approved geotechnical report(s) and grading plan(s). If, in the opinion of the Geotechnical Consultant, unsatisfactory conditions, such as unsuitable soil, improper moisture condition, inadequate compaction, insufficient buttress key size, adverse weather, etc., are resulting in a quality of work less than required in these specifications, the Geotechnical Consultant shall reject the work and may recommend to the owner that construction be stopped until the conditions are rectified.

2.0 Preparation of Areas to be Filled

2.1 Clearing and Grubbing

Vegetation, such as brush, grass, roots, and other deleterious material shall be sufficiently removed and properly disposed of in a method acceptable to the owner, governing agencies, and the Geotechnical Consultant.

The Geotechnical Consultant shall evaluate the extent of these removals depending on specific site conditions. Earth fill material shall not contain more than 1 percent of organic materials (by volume). No fill lift shall contain more than 5 percent of organic matter. Nesting of the organic materials shall not be allowed.

If potentially hazardous materials are encountered, the Contractor shall stop work in the affected area, and a hazardous material specialist shall be informed immediately for proper evaluation and handling of these materials prior to continuing to work in that area.

As presently defined by the State of California, most refined petroleum products (gasoline, diesel fuel, motor oil, grease, coolant, etc.) have chemical constituents that are considered to be hazardous waste. As such, the indiscriminate dumping or spillage of these fluids onto the ground may constitute a misdemeanor, punishable by fines and/or imprisonment, and shall not be allowed.

2.2 Processing

Existing ground that has been declared satisfactory for support of fill by the Geotechnical Consultant shall be scarified to a minimum depth of 6 inches. Existing ground that is not satisfactory shall be overexcavated as specified in the following section. Scarification shall continue until soils are broken down and free of large clay lumps or clods and the working surface is reasonably uniform, flat, and free of uneven features that would inhibit uniform compaction.

2.3 Overexcavation

In addition to removals and overexcavations recommended in the approved geotechnical report(s) and the grading plan, soft, loose, dry, saturated, spongy, organic-rich, highly fractured or otherwise unsuitable ground shall be overexcavated to competent ground as evaluated by the Geotechnical Consultant during grading.

2.4 Benching

Where fills are to be placed on ground with slopes steeper than 5:1 (horizontal to vertical units), the ground shall be stepped or benched. Please see the Standard Details for a graphic illustration. The lowest bench or key shall be a minimum of 15 feet wide and at least 2 feet deep, into competent material as evaluated by the Geotechnical Consultant. Other benches shall be excavated a minimum height of 4 feet into competent material or as otherwise recommended by the Geotechnical Consultant. Fill placed on ground sloping flatter than 5:1 shall also be benched or otherwise overexcavated to provide a flat subgrade for the fill.

2.5 Evaluation/Acceptance of Fill Areas

All areas to receive fill, including removal and processed areas, key bottoms, and benches, shall be observed, mapped, elevations recorded, and/or tested prior to being accepted by the Geotechnical Consultant as suitable to receive fill. The Contractor shall obtain a written acceptance from the Geotechnical Consultant

prior to fill placement. A licensed surveyor shall provide the survey control for determining elevations of processed areas, keys, and benches.

3.0 Fill Material

3.1 General

Material to be used as fill shall be essentially free of organic matter and other deleterious substances evaluated and accepted by the Geotechnical Consultant prior to placement. Soils of poor quality, such as those with unacceptable gradation, high expansion potential, or low strength shall be placed in areas acceptable to the Geotechnical Consultant or mixed with other soils to achieve satisfactory fill material.

3.2 Oversize

Oversize material defined as rock, or other irreducible material with a maximum dimension greater than 8 inches, shall not be buried or placed in fill unless location, materials, and placement methods are specifically accepted by the Geotechnical Consultant. Placement operations shall be such that nesting of oversized material does not occur and such that oversize material is completely surrounded by compacted or densified fill. Oversize material shall not be placed within 10 vertical feet of finish grade or within 2 feet of future utilities or underground construction.

3.3 Import

If importing of fill material is required for grading, proposed import material shall meet the requirements of Section 3.1. The potential import source shall be given to the Geotechnical Consultant at least 48 hours (2 working days) before importing begins so that its suitability can be determined and appropriate tests performed.

4.0 Fill Placement and Compaction

4.1 Fill Layers

Approved fill material shall be placed in areas prepared to receive fill (per Section 3.0) in near-horizontal layers not exceeding 8 inches in loose thickness. The Geotechnical Consultant may accept thicker layers if testing indicates the grading procedures can adequately compact the thicker layers. Each layer shall be spread evenly and mixed thoroughly to attain relative uniformity of material and moisture throughout.

4.2 Fill Moisture Conditioning

Fill soils shall be watered, dried back, blended, and/or mixed, as necessary to attain a relatively uniform moisture content at or slightly over optimum. Maximum density and optimum soil moisture content tests shall be performed in accordance with the American Society of Testing and Materials (ASTM Test Method D1557).

4.3 Compaction of Fill

After each layer has been moisture-conditioned, mixed, and evenly spread, it shall be uniformly compacted to not less than 90 percent of maximum dry density (ASTM Test Method D1557). Compaction equipment shall be adequately sized and be either specifically designed for soil compaction or of proven reliability to efficiently achieve the specified level of compaction with uniformity.

4.4 Compaction of Fill Slopes

In addition to normal compaction procedures specified above, compaction of slopes shall be accomplished by backrolling of slopes with sheepsfoot rollers at increments of 3 to 4 feet in fill elevation, or by other methods producing satisfactory results acceptable to the Geotechnical Consultant. Upon completion of grading, relative compaction of the fill, out to the slope face, shall be at least 90 percent of maximum density per ASTM Test Method D1557.

4.5 Compaction Testing

Field-tests for moisture content and relative compaction of the fill soils shall be performed by the Geotechnical Consultant. Location and frequency of tests shall be at the Consultant's discretion based on field conditions encountered. Compaction test locations will not necessarily be selected on a random basis. Test locations shall be selected to verify adequacy of compaction levels in areas that are judged to be prone to inadequate compaction (such as close to slope faces and at the fill/bedrock benches).

4.6 Frequency of Compaction Testing

Tests shall be taken at intervals not exceeding 2 feet in vertical rise and/or 1,000 cubic yards of compacted fill soils embankment. In addition, as a guideline, at least one test shall be taken on slope faces for each 5,000 square feet of slope face and/or each 10 feet of vertical height of slope. The Contractor shall assure that fill construction is such that the testing schedule can be accomplished by the Geotechnical Consultant. The Contractor shall stop or slow down the earthwork construction if these minimum standards are not met.

4.7 Compaction Test Locations

The Geotechnical Consultant shall document the approximate elevation and horizontal coordinates of each test location. The Contractor shall coordinate with the project surveyor to assure that sufficient grade stakes are established so that the Geotechnical Consultant can determine the test locations with sufficient accuracy. At a minimum, two grade stakes within a horizontal distance of 100 feet and vertically less than 5 feet apart from potential test locations shall be provided.

5.0 Subdrain Installation

Subdrain systems shall be installed in accordance with the approved geotechnical report(s), the grading plan, and the Standard Details. The Geotechnical Consultant may recommend additional subdrains and/or changes in subdrain extent, location, grade, or material depending on conditions encountered during grading. All subdrains shall be surveyed by a land surveyor/civil engineer for line and grade after installation and prior to burial. Sufficient time should be allowed by the Contractor for these surveys.

6.0 Excavation

Excavations, as well as over-excavation for remedial purposes, shall be evaluated by the Geotechnical Consultant during grading. Remedial removal depths shown on geotechnical plans are estimates only. The actual extent of removal shall be determined by the Geotechnical Consultant based on the field evaluation of exposed conditions during grading. Where fill-over-cut slopes are to be graded, the cut portion of the slope shall be made, evaluated, and accepted by the Geotechnical Consultant prior to placement of materials for construction of the fill portion of the slope, unless otherwise recommended by the Geotechnical Consultant.

7.0 Trench Backfills

7.1 Safety

The Contractor shall follow all OSHA and Cal/OSHA requirements for safety of trench excavations.

7.2 Bedding and Backfill

All bedding and backfill of utility trenches shall be performed in accordance with the applicable provisions of Standard Specifications of Public Works Construction. Bedding material shall have a Sand Equivalent greater than 30 (SE>30). The bedding shall be placed to 1 foot over the top of the conduit and densified. Backfill shall be placed and densified to a minimum of 90 percent of relative compaction from 1 foot above the top of the conduit to the surface.

The Geotechnical Consultant shall test the trench backfill for relative compaction. At least one test should be made for every 300 feet of trench and 2 feet of fill.

7.3 Lift Thickness

Lift thickness of trench backfill shall not exceed those allowed in the Standard Specifications of Public Works Construction unless the Contractor can demonstrate to the Geotechnical Consultant that the fill lift can be compacted to the minimum relative compaction by his alternative equipment and method.

7.4 Observation and Testing

The densification of the bedding around the conduits shall be observed by the Geotechnical Consultant.-----

FILL SLOPE

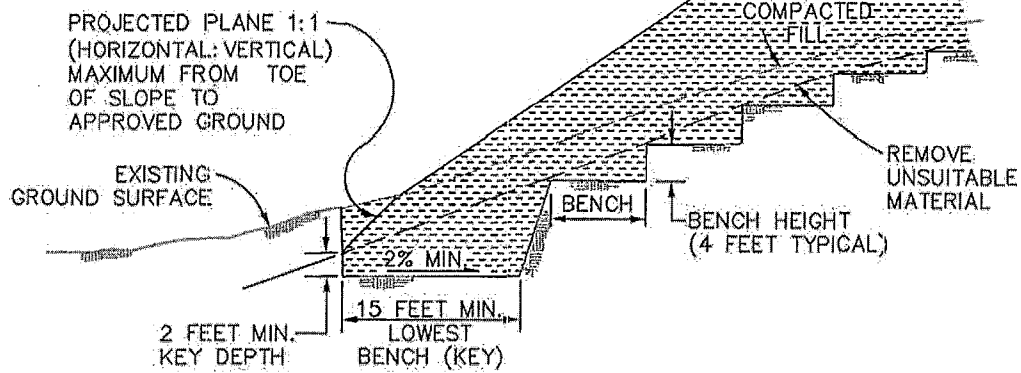

FILL-OVER-CUT SLOPE

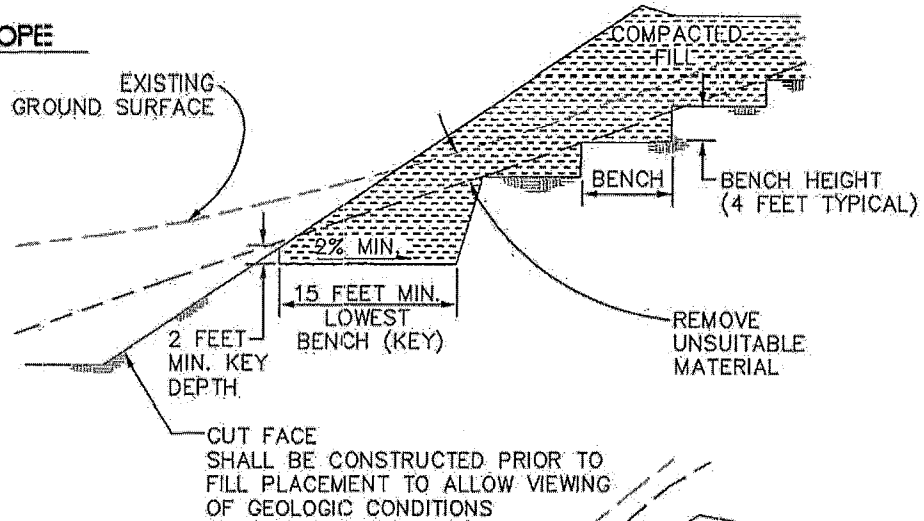

CUT-OVER-FILL SLOPE

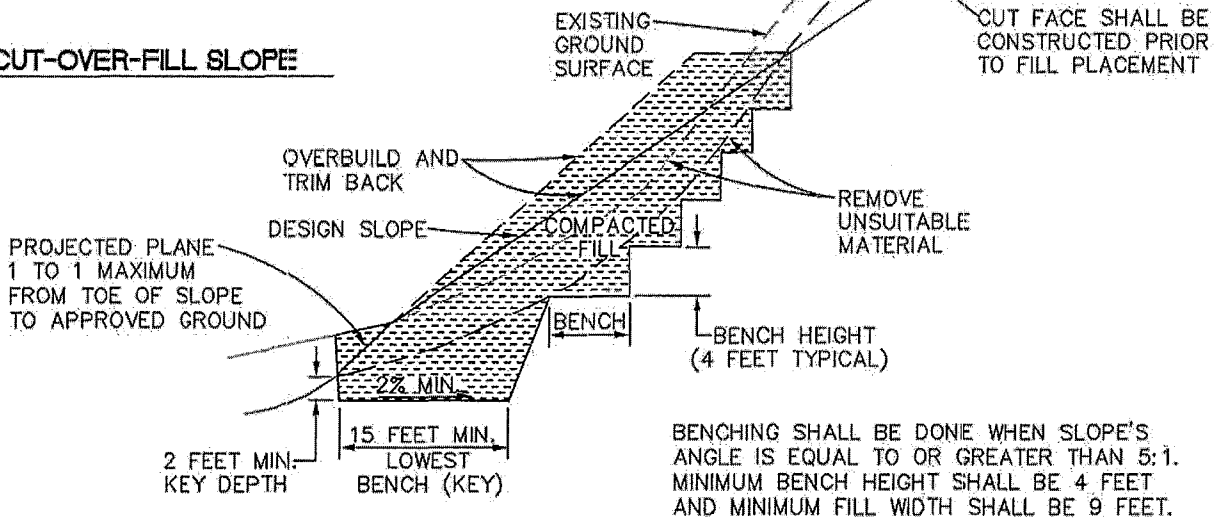

KEYING AND BENCHING

GENERAL EARTHWORK AND
GRADING SPECIFICATIONS
STANDARD DETAIL A



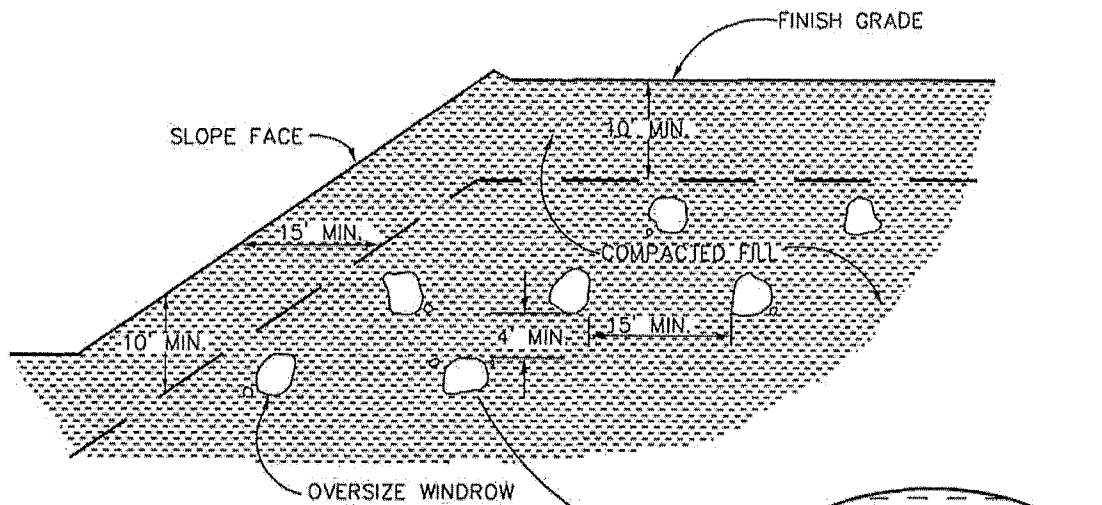

- * OVERSIZE ROCK IS LARGER THAN 8 INCHES IN LARGEST DIMENSION.
- * EXCAVATE A TRENCH IN THE COMPACTED FILL DEEP ENOUGH TO BURY ALL THE ROCK.
- * BACKFILL WITH GRANULAR SOIL JETTED OR FLOODED IN PLACE TO FILL ALL THE VOIDS.
- * DO NOT BURY ROCK WITHIN 10 FEET OF FINISH GRADE.
- * WINDROW OF BURIED ROCK SHALL BE PARALLEL TO THE FINISHED SLOPE.

GRANULAR MATERIAL TO BE DENSIFIED IN PLACE BY FLOODING OR JETTING.

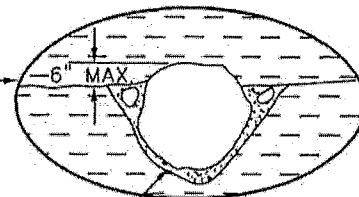

DETAIL

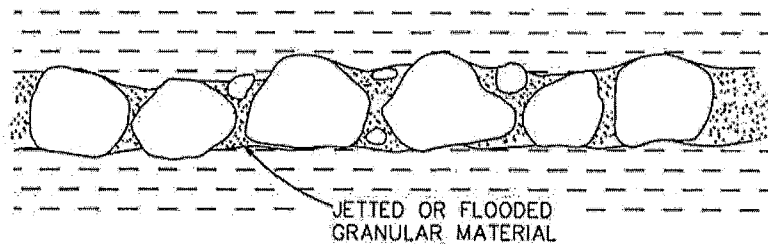

TYPICAL PROFILE ALONG WINDROW

OVERSIZE ROCK DISPOSAL

GENERAL EARTHWORK AND GRADING SPECIFICATIONS
STANDARD DETAIL B



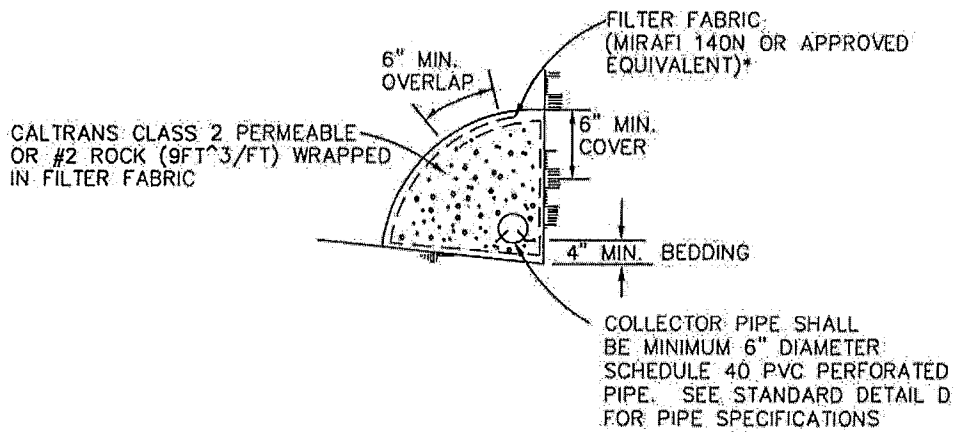
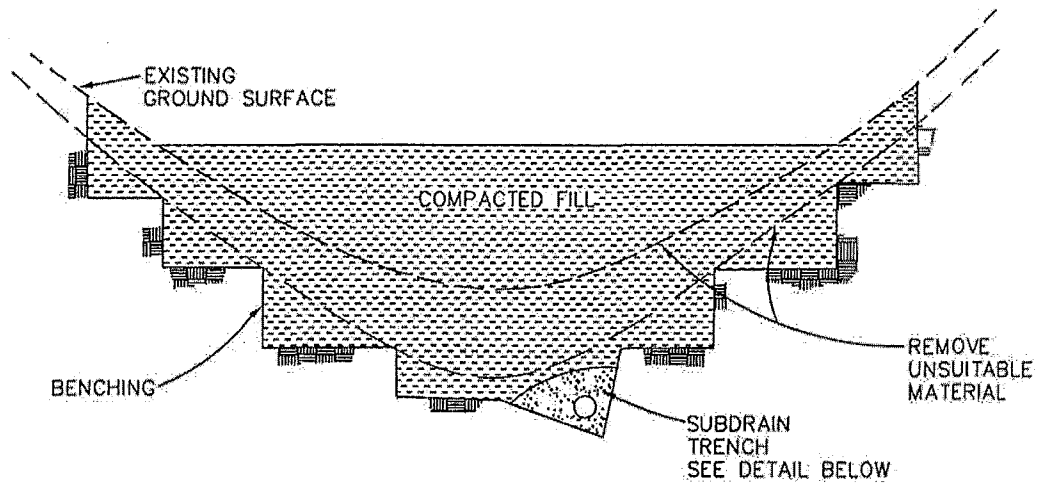

SUBDRAIN DETAIL

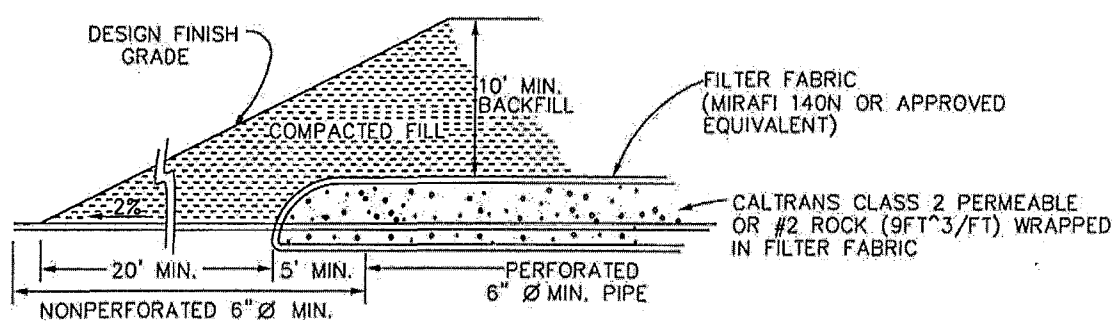

DETAIL OF CANYON SUBDRAIN OUTLET

CANYON SUBDRAINS

GENERAL EARTHWORK AND GRADING SPECIFICATIONS
STANDARD DETAIL C



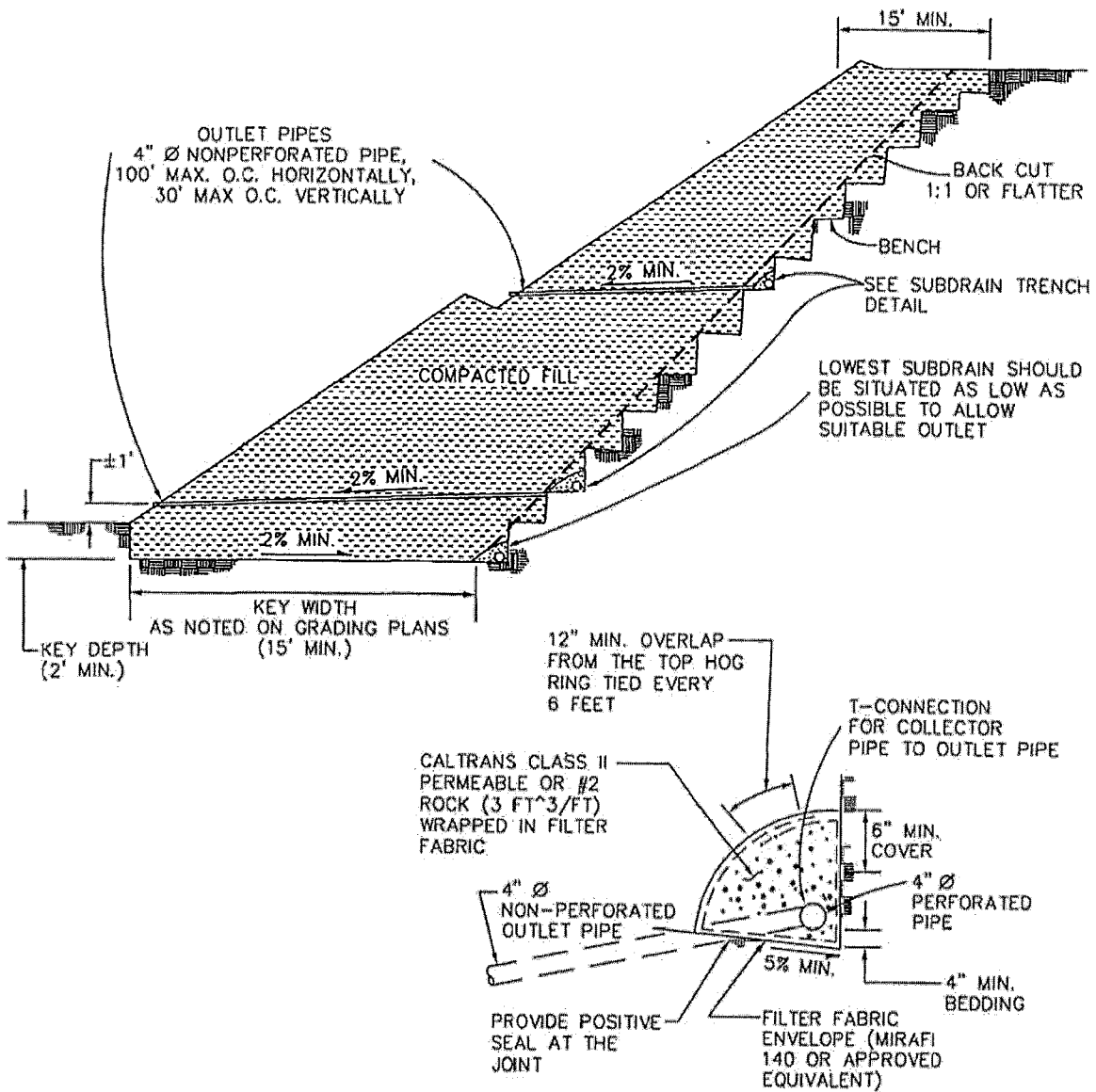

SUBDRAIN TRENCH DETAIL

SUBDRAIN INSTALLATION - subdrain collector pipe shall be installed with perforation down or, unless otherwise designated by the geotechnical consultant. Outlet pipes shall be non-perforated pipe. The subdrain pipe shall have at least 8 perforations uniformly spaced per foot. Perforation shall be 1/4" to 1/2" if drill holes are used. All subdrain pipes shall have a gradient of at least 2% towards the outlet.

SUBDRAIN PIPE - Subdrain pipe shall be ASTM D2751, SDR 23.5 or ASTM D1527, Schedule 40, or ASTM D3034, SDR 23.5, Schedule 40 Polyvinyl Chloride Plastic (PVC) pipe.

All outlet pipe shall be placed in a trench no wider than twice the subdrain pipe.

**BUTTRESS OR
REPLACEMENT
FILL SUBDRAINS**

**GENERAL EARTHWORK AND
GRADING SPECIFICATIONS
STANDARD DETAIL D**



CUT-FILL TRANSITION LOT OVEREXCAVATION

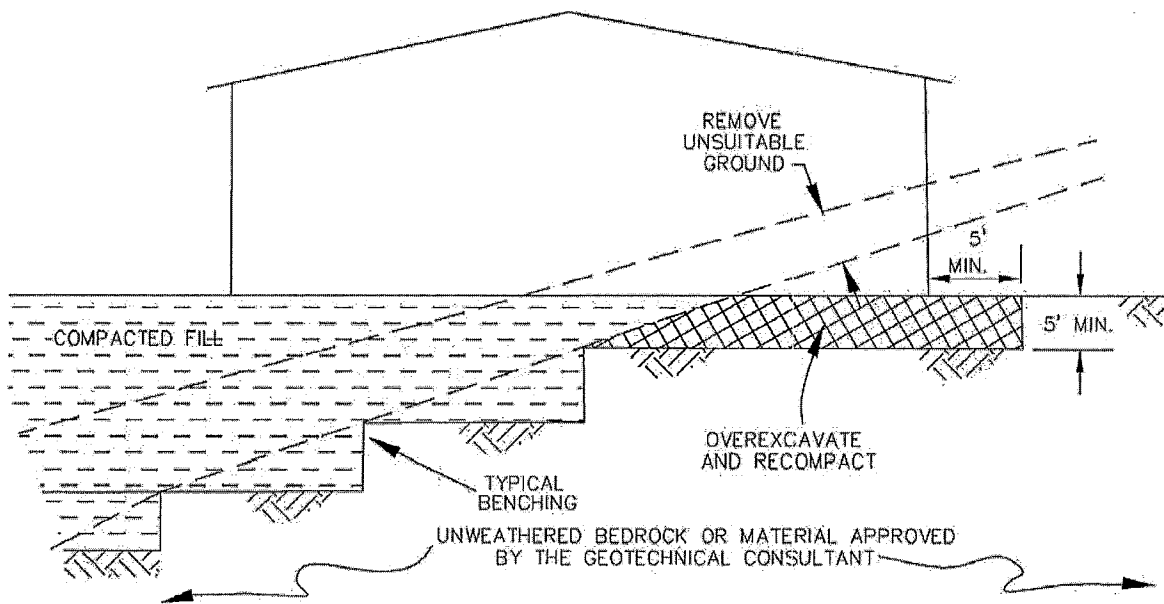

TRANSITION LOT FILLS

GENERAL EARTHWORK AND
GRADING SPECIFICATIONS
STANDARD DETAIL E



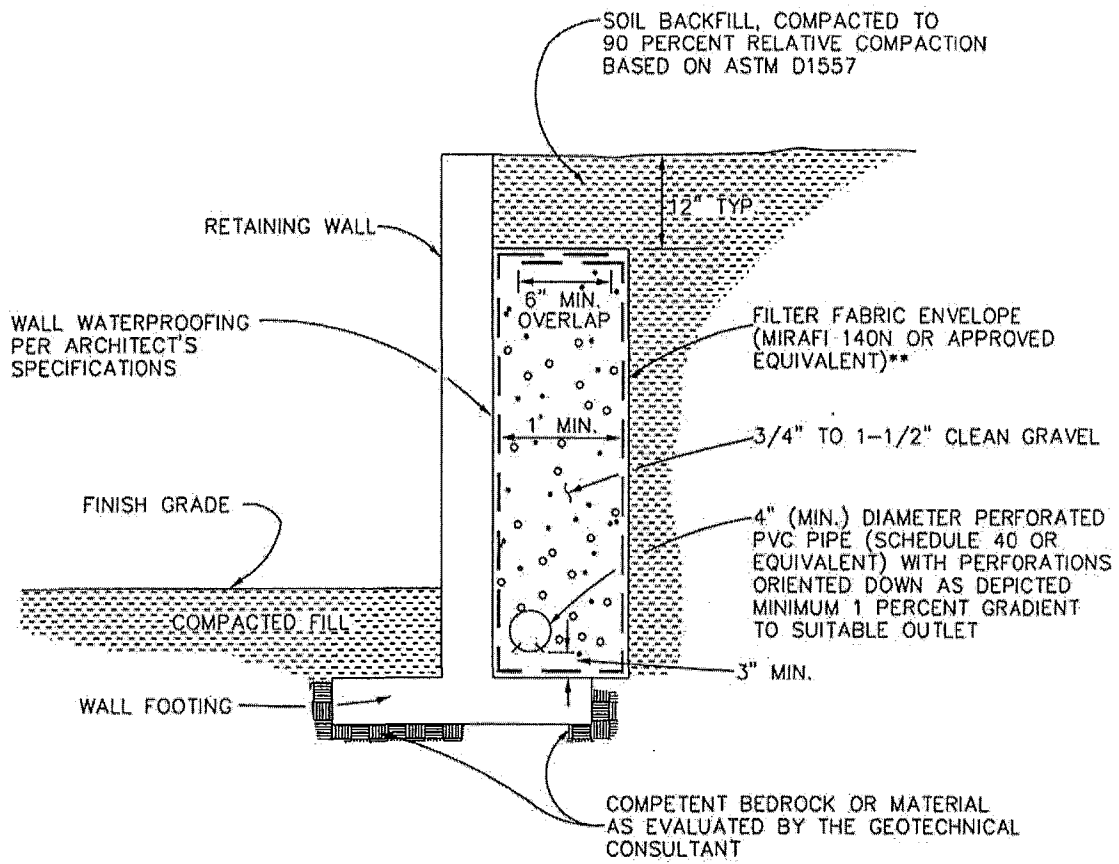

NOTE: UPON REVIEW BY THE GEOTECHNICAL CONSULTANT, COMPOSITE DRAINAGE PRODUCTS SUCH AS MIRADRAIN OR J-DRAIN MAY BE USED AS AN ALTERNATIVE TO GRAVEL OR CLASS 2 PERMEABLE MATERIAL. INSTALLATION SHOULD BE PERFORMED IN ACCORDANCE WITH MANUFACTURER'S SPECIFICATIONS.

RETAINING WALL DRAINAGE

GENERAL EARTHWORK AND GRADING SPECIFICATIONS
STANDARD DETAIL F



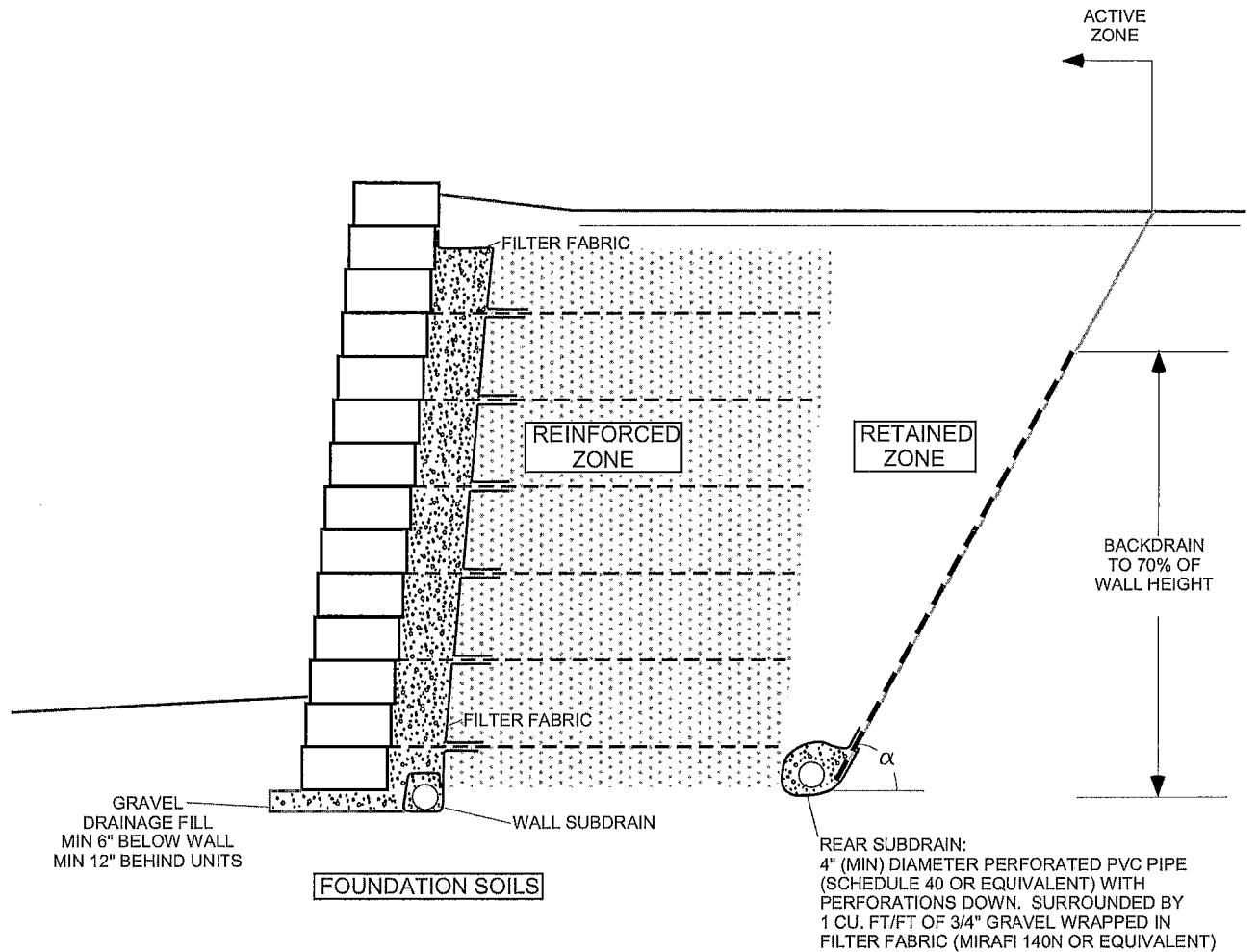

NOTES:

- 1) MATERIAL GRADATION AND PLASTICITY
REINFORCED ZONE:

SIEVE SIZE	% PASSING
1 INCH	100
NO. 4	20-100
NO. 40	0-60
NO. 200	0-35

FOR WALL HEIGHT < 10 FEET, PLASTICITY INDEX < 20
 FOR WALL HEIGHT 10 TO 20 FEET, PLASTICITY INDEX < 10
 FOR TIERED WALLS, USE COMBINED WALL HEIGHTS
 WALL DESIGNER TO REQUEST SITE-SPECIFIC CRITERIA FOR WALL HEIGHT > 20 FEET

GRAVEL DRAINAGE FILL:

SIEVE SIZE	% PASSING
1 INCH	100
3/4 INCH	75-100
NO. 4	0-60
NO. 40	0-50
NO. 200	0-5

- 2) CONTRACTOR TO USE SOILS WITHIN THE RETAINED AND REINFORCED ZONES THAT MEET THE STRENGTH REQUIREMENTS OF WALL DESIGN.
- 3) GEOGRID REINFORCEMENT TO BE DESIGNED BY WALL DESIGNER CONSIDERING INTERNAL, EXTERNAL, AND COMPOUND STABILITY.
- 3) GEOGRID TO BE PRETENSIONED DURING INSTALLATION.
- 4) IMPROVEMENTS WITHIN THE ACTIVE ZONE ARE SUSCEPTIBLE TO POST-CONSTRUCTION SETTLEMENT. ANGLE $\alpha = 45 + \phi/2$, WHERE ϕ IS THE FRICTION ANGLE OF THE MATERIAL IN THE RETAINED ZONE.
- 5) BACKDRAIN SHOULD CONSIST OF J-DRAIN 302 (OR EQUIVALENT) OR 6-INCH THICK DRAINAGE FILL WRAPPED IN FILTER FABRIC. PERCENT COVERAGE OF BACKDRAIN TO BE PER GEOTECHNICAL REVIEW.

SEGMENTAL RETAINING WALLS

GENERAL EARTHWORK AND GRADING SPECIFICATIONS STANDARD DETAIL G



APPENDIX O

COASTAL DEVELOPMENT PERMIT AND SITE DEVELOPMENT PERMITS

DOC# 2016-0683873



Dec 14, 2016 10:36 AM
OFFICIAL RECORDS
Ernest J. Dronenburg, Jr.,
SAN DIEGO COUNTY RECORDER
FEES: \$48.00

PAGES: 12

RECORDING REQUESTED BY
CITY OF SAN DIEGO
DEVELOPMENT SERVICES
PERMIT INTAKE, MAIL STATION
501

WHEN RECORDED MAIL TO
PROJECT MANAGEMENT
PERMIT CLERK
MAIL STATION 501

SPACE ABOVE THIS LINE FOR RECORDER'S USE

INTERNAL ORDER NUMBER: WBS#-5-00877.02.06

COASTAL DEVELOPMENT PERMIT NO. 846963 and
SITE DEVELOPMENT PERMIT NO. 846964
TORREY PINES SLOPE RESTORATION PROJECT NO. 236131
HEARING OFFICER

This Coastal Development Permit No. 846963 and Site Development Permit No. 846964 is granted by the Hearing Officer of the City of San Diego to the City of San Diego, Public Works Department, Owner/Permittee, pursuant to San Diego Municipal Code Sections 126.0501 and 126.0401. The site is located within the Torrey Pines Road public right-of-way between Little Street and Roseland Drive in the La Jolla Community Plan area. The project site is legally described as public right-of-way of Torrey Pines Road.

Subject to the terms and conditions set forth in this Permit, permission is granted to Owner/Permittee to allow the restoration and stabilization of an existing slope within the Torrey Pines Road public right-of-way between Little Street and Roseland Drive by installing an approximately 334 foot long, approximately twenty-four foot high soil-nails retaining wall described and identified by size, dimension, quantity, type, and location on the approved exhibits [Exhibit "A"] dated November 9, 2016, on file in the Development Services Department.

The project shall include:

- a. The Torrey Pines Slope Restoration project includes an excavation at the toe of the existing slope to achieve the required space for a sidewalk, removal of existing gunite, sloughing soil and debris off the existing slope face, and installation of a permanent soil-nails wall with an outer boulder-scape or rock carved surface within the Torrey Pines Road public right-of-way;
- b. Erosion control within the Torrey Pines Road public right-of-way (planting, irrigation and landscape related improvements);



- c. Public and private accessory improvements determined by the Development Services Department to be consistent with the land use and development standards for this site in accordance with the adopted community plan, the California Environmental Quality Act [CEQA] and the CEQA Guidelines, the City Engineer's requirements, zoning regulations, conditions of this Permit, and any other applicable regulations of the SDMC.

STANDARD REQUIREMENTS:

1. This permit must be utilized within thirty-six (36) months after the date on which all rights of appeal have expired. If this permit is not utilized in accordance with Chapter 12, Article 6, Division 1 of the SDMC within the 36 month period, this permit shall be void unless an Extension of Time has been granted. Any such Extension of Time must meet all SDMC requirements and applicable guidelines in effect at the time the extension is considered by the appropriate decision maker. This permit must be utilized by November 24, 2019.
2. No permit for the construction or improvement described herein shall be granted, nor shall any activity authorized by this Permit be conducted on the premises until:
 - a. The Owner/Permittee signs and returns the Permit to the Development Services Department; and
 - b. The Permit is recorded in the Office of the San Diego County Recorder.
3. This Permit is a covenant running with the subject property and all of the requirements and conditions of this Permit and related documents shall be binding upon the Owner/Permittee and any successor(s) in interest.
4. The continued use of this Permit shall be subject to the regulations of this and any other applicable governmental agency.
5. Issuance of this Permit by the City of San Diego does not authorize the Owner/Permittee for this Permit to violate any Federal, State or City laws, ordinances, regulations or policies including, but not limited to, the Endangered Species Act of 1973 [ESA] and any amendments thereto (16 U.S.C. § 1531 et seq.).
6. Construction plans shall be in substantial conformity to Exhibit "A." Changes, modifications, or alterations to the construction plans are prohibited unless appropriate application(s) or amendment(s) to this Permit have been granted.
7. All of the conditions contained in this Permit have been considered and were determined-necessary to make the findings required for approval of this Permit. The Permit holder is required to comply with each and every condition in order to maintain the entitlements that are granted by this Permit.

If any condition of this Permit, on a legal challenge by the Owner/Permittee of this Permit, is found or held by a court of competent jurisdiction to be invalid, unenforceable, or unreasonable, this



Permit shall be void. However, in such an event, the Owner/Permittee shall have the right, by paying applicable processing fees, to bring a request for a new permit without the "invalid" condition(s) back to the discretionary body which approved the Permit for a determination by that body as to whether all of the findings necessary for the issuance of the proposed permit can still be made in the absence of the "invalid" condition(s). Such hearing shall be a hearing de novo, and the discretionary body shall have the absolute right to approve, disapprove, or modify the proposed permit and the condition(s) contained therein.

LANDSCAPE REQUIREMENTS:

8. Construction documents for the revegetation and hydroseeding of all disturbed land shall be in accordance with the Landscape Standards. All plans shall be in substantial conformance to this permit and Exhibit "A," on file in the Office of the Development Services Department.

9. All required landscape shall be maintained in a disease, weed and litter free condition at all times. Severe pruning or "topping" of trees is not permitted unless specifically noted in this Permit.

10. The Owner/Permittee shall be responsible for the maintenance of all landscape improvements shown on the approved plans, including in the right-of-way, consistent with the Landscape Standards unless long-term maintenance of said landscaping will be the responsibility of a Landscape Maintenance District or other approved entity.

11. If any required landscape, including existing or new plantings, hardscape, landscape features, et cetera, indicated on the approved construction document plans is damaged or removed during demolition or construction, it shall be repaired and/or replaced in kind and equivalent size per the approved documents.

INFORMATION ONLY:

- The issuance of this discretionary use permit alone does not allow the immediate commencement or continued operation of the proposed use on site. The operation allowed by this discretionary use permit may only begin or recommence after all conditions listed on this permit are fully completed and all required ministerial permits have been issued and received final inspection.
- Any party on whom fees, dedications, reservations, or other exactions have been imposed as conditions of approval of this Permit, may protest the imposition within ninety days of the approval of this development permit by filing a written protest with the City Clerk pursuant to California Government Code-section 66020.
- This development may be subject to impact fees at the time of construction permit issuance.

APPROVED by the Hearing Officer of the City of San Diego on November 9, 2016 by Resolution HO-6974.



Permit Type/PTS Approval No.: CDP No. 846963 & SDP No. 846964
Date of Approval: November 9, 2016

AUTHENTICATED BY THE CITY OF SAN DIEGO DEVELOPMENT SERVICES DEPARTMENT

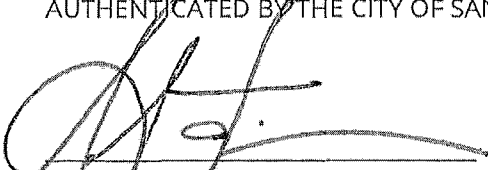

John S. Fisher
Development Project Manager

**NOTE: Notary acknowledgment
must be attached per Civil Code
section 1189 et seq.**

The undersigned Owner/Permittee, by execution hereof, agrees to each and every condition of this Permit and promises to perform each and every obligation of Owner/Permittee hereunder.

**Public Works Department,
City of San Diego**
Owner/Permittee

By 
Jamal Batta
Senior Civil Engineer

**NOTE: Notary acknowledgments
must be attached per Civil Code
section 1189 et seq.**



CALIFORNIA ALL-PURPOSE ACKNOWLEDGMENT

CIVIL CODE § 1189

A notary public or other officer completing this certificate verifies only the identity of the individual who signed the document to which this certificate is attached, and not the truthfulness, accuracy, or validity of that document.

State of California)
County of San Diego)
On December 13, 2016 before me, Vivian M. Gies, Notary Public
Date Here Insert Name and Title of the Officer
personally appeared John S. Fisher, Jamal Batta
Name(s) of Signer(s)

who proved to me on the basis of satisfactory evidence to be the person(s) whose name(s) is/are subscribed to the within instrument and acknowledged to me that he/she/they executed the same in his/her/their authorized capacity(ies), and that by his/her/their signature(s) on the instrument the person(s), or the entity upon behalf of which the person(s) acted, executed the instrument.

I certify under PENALTY OF PERJURY under the laws of the State of California that the foregoing paragraph is true and correct.
WITNESS my hand and official seal.



Signature Vivian M. Gies
Signature of Notary Public

Place Notary Seal Above

OPTIONAL

Though this section is optional, completing this information can deter alteration of the document or fraudulent reattachment of this form to an unintended document.

Description of Attached Document PTS #236131/Torrey Pines Slope Restoration/CDP #846963
Title or Type of Document: SDP #846964 Document Date: _____
Number of Pages: _____ Signer(s) Other Than Named Above: _____

Capacity(ies) Claimed by Signer(s)
Signer's Name: _____ Signer's Name: _____
 Corporate Officer — Title(s): _____ Corporate Officer — Title(s): _____
 Partner — Limited General Partner — Limited General
 Individual Attorney in Fact Individual Attorney in Fact
 Trustee Guardian or Conservator Trustee Guardian or Conservator
 Other: _____ Other: _____
Signer Is Representing: _____ Signer Is Representing: _____

HEARING OFFICER RESOLUTION NO. HO-6974
COASTAL DEVELOPMENT PERMIT NO. 846963 and
SITE DEVELOPMENT PERMIT NO. 846964
TORREY PINES SLOPE RESTORATION PROJECT NO. 236131

WHEREAS the CITY OF SAN DIEGO, PUBLIC WORKS DEPARTMENT, Owner/Permittee, filed an application with the City of San Diego for a permit to allow the restoration and stabilization of an existing slope along Torrey Pines Road between Little Street and Roseland Drive by installing an approximately 334 foot long, approximately twenty-seven foot high soil-nails retaining wall (as described in and by reference to the approved Exhibits "A" and corresponding conditions of approval for the associated Permit Nos. 846963 and 846964), within Torrey Pines Road public right-of-way between Little Street and Roseland Drive;

WHEREAS, the project site is located within the Torrey Pines Road public right-of-way between Little Street and Roseland Drive of the La Jolla Community Plan area;

WHEREAS, the project site is legally described as a portion of public right-of-way of Torrey Pines Road;

WHEREAS, on November 9, 2016, the Hearing Officer of the City of San Diego considered Coastal Development Permit No. 846963 and Site Development Permit No. 846964 pursuant to the Land Development Code of the City of San Diego;

WHEREAS, on October 8, 2013, the City of San Diego, as Lead Agency, through the Development Services Department, made and issued an Environmental Determination that the project is exempt from the California Environmental Quality Act (CEQA) (Public Resources Code section 21000 et. seq.) under CEQA Guideline Section 15302 (Replacement or Reconstruction); and there was no appeal of the Environmental Determination filed within the time period provided by San Diego Municipal Code Section 112.0520;

NOW, THEREFORE, BE IT RESOLVED by the Hearing Officer of the City of San Diego as follows:

That the Hearing Officer adopts the following written Findings, dated November 9, 2016.

FINDINGS:

Coastal Development Permit - Section 126.0708

- 1. The proposed coastal development will not encroach upon any existing physical accessway that is legally used by the public or any proposed public accessway identified in a Local Coastal Program land use plan; and the proposed coastal development will enhance and protect public views to and along the ocean and other scenic coastal areas as specified in the Local Coastal Program land use plan.** The proposed project will improve the public safety within the public right-of-way along Torrey Pines Road between Little Street and Roseland Drive by installing an approximately 334 foot long, approximately twenty-seven foot high soil-nails retaining wall. The Torrey Pines Slope Restoration project includes excavation at the toe

of the existing slope to achieve the required space for a sidewalk, removal of sloughing soil and debris off the existing slope face, and installation of a permanent soil-nails wall with an outer boulder-scape or rock carved surface. Several of the excavated slopes along the existing Torrey Pines Road were sprayed with gunite, a building material consisting of a mixture of cement, sand, and water that is sprayed into place. Gunite has little or no structural strength in that the mixture has no rock and no steel and is generally very thinly applied. Gunite has been used on slopes to prevent erosion of steep slopes. Gunite has no structural properties and is simply a thinly applied mixture of water, cement and sand. The existing condition presents a public safety concern. During intense storm events eroded material collects in the east-bound travel lane closest to the curb. A complete failure of the slope is possible.

The soil-nails wall would be approximately twenty-seven feet in height and approximately 334 feet in length. The soil-nails, up to forty feet in length, would be installed into the slope at an angle of approximately fifteen degrees below horizontal. The horizontal and vertical spaces of the soil-nails would be approximately six feet. Approximately 250 soil-nails would be used to construct a permanent wall. A permanent safety railing would be installed atop the soil-nails wall measuring forty-four inches high. A concrete brow ditch would be installed behind the soil-nails wall to intercept drainage from above and carry the stormwater runoff away from the soil-nails wall. A geocomposite drain system and weep holes would be integrated into the construction to eliminate hydrostatic pressure from building up behind the soil-nails wall. The proposed project will replace the existing gunite on the slope face with a soil-nails retaining wall and improve the safety of the transportation corridor.

The proposed project is the improvement of an existing public right-of-way used by the public to existing physical accessways legally. The proposed project will not encroach upon any existing physical accessway that is legally used by the public or any proposed public accessway identified in a Local Coastal Program land use plan. There are no public views to and along the ocean and other scenic coastal areas where the improvement will be constructed. The proposed project will neither enhance nor detract and neither protect or degrade public views to and along the ocean and other scenic coastal areas as specified in the Local Coastal Program land use plan. The proposed project will improve the public's safety when traveling through the transportation corridor. Therefore, the proposed coastal development will not encroach upon any existing physical accessway that is legally used by the public or any proposed public accessway identified in a Local Coastal Program land use plan and the proposed coastal development will enhance and protect public views to and along the ocean and other scenic coastal areas as specified in the Local Coastal Program land use plan.

2. **The proposed coastal development will not adversely affect environmentally sensitive lands.** The proposed project will improve the public safety within the public right-of-way along Torrey Pines Road between Little Street and Roseland Drive by installing an approximately 334 foot long, approximately twenty-seven foot high soil-nails retaining wall. The Torrey Pines Slope Restoration project includes excavation at the toe of the existing slope to achieve the required space for a sidewalk, removal of sloughing soil and debris off the existing slope face, and installation of a permanent soil-nails wall with an outer boulder-scape or rock carved surface. Several of the excavated slopes along the existing Torrey Pines Road were sprayed with gunite, a building material consisting of a mixture of cement, sand, and water that is sprayed into place. Gunite has little or no structural strength in that the mixture has no rock and no steel and is generally very thinly applied.

Gunite has been used on slopes to prevent erosion of steep slopes. Gunite has no structural properties and is simply a thinly applied mixture of water, cement and sand. The existing condition presents a public safety concern. During intense storm events eroded material collects in the east-bound travel lane closest to the curb. A complete failure of the slope is possible.

The soil-nails wall would be approximately twenty-seven feet in height and approximately 334 feet in length. The soil-nails, up to forty feet in length, would be installed into the slope at an angle of approximately fifteen degrees below horizontal. The horizontal and vertical spaces of the soil-nails would be approximately six feet. Approximately 250 soil-nails would be used to construct a permanent wall. A permanent safety railing would be installed atop the soil-nails wall measuring forty-four inches high. A concrete brow ditch would be installed behind the soil-nails wall to intercept drainage from above and carry the stormwater runoff away from the soil-nails wall. A geocomposite drain system and weep holes would be integrated into the construction to eliminate hydrostatic pressure from building up behind the soil-nails wall. The proposed project will replace the existing gunite on the slope face with a soil-nails retaining wall and improve the safety of the transportation corridor.

The applicant submitted a Biological assessment of the site. The conclusion of that assessment is the public right-of-way along Torrey Pines Road between Little Street and Roseland Drive contains no environmentally sensitive lands. Therefore, the proposed coastal development will not adversely affect environmentally sensitive lands.

3. The proposed coastal development is in conformity with the certified Local Coastal Program land use plan and complies with all regulations of the certified Implementation Program. The proposed project will improve the public safety within the public right-of-way along Torrey Pines Road between Little Street and Roseland Drive by installing an approximately 334 foot long, approximately twenty-seven foot high soil-nails retaining wall. The Torrey Pines Slope Restoration project includes excavation at the toe of the existing slope to achieve the required space for a sidewalk, removal of sloughing soil and debris off the existing slope face, and installation of a permanent soil-nails wall with an outer boulder-scape or rock carved surface. Several of the excavated slopes along the existing Torrey Pines Road were sprayed with gunite, a building material consisting of a mixture of cement, sand, and water that is sprayed into place. Gunite has little or no structural strength in that the mixture has no rock and no steel and is generally very thinly applied. Gunite has been used on slopes to prevent erosion of steep slopes. Gunite has no structural properties and is simply a thinly applied mixture of water, cement and sand. The existing condition presents a public safety concern. During intense storm events eroded material collects in the east-bound travel lane closest to the curb. A complete failure of the slope is possible.

The soil-nails wall would be approximately twenty-seven feet in height and approximately 334 feet in length. The soil-nails, up to forty feet in length, would be installed into the slope at an angle of approximately fifteen degrees below horizontal. The horizontal and vertical spaces of the soil-nails would be approximately six feet. Approximately 250 soil-nails would be used to construct a permanent wall. A permanent safety railing would be installed atop the soil-nails wall measuring forty-four inches high. A concrete brow ditch would be installed behind the soil-nails wall to intercept drainage from above and carry the stormwater runoff away from the soil-nails wall. A geocomposite drain system and weep holes would be integrated into the construction to eliminate hydrostatic pressure from building up behind the soil-nails wall. The proposed project will replace the existing gunite on the slope face with a soil-nails retaining wall and improve the safety of the transportation corridor.

The proposed project will be consistent with the transportation goals of the La Jolla Community Plan. The proposed project will replace the existing gunite on the slope face with a soil-nails retaining wall and improve the safety of the transportation corridor. Torrey Pines Road is an integral link in the Transportation Element and is a circulation element roadway. Safety of persons, vehicles and cargo is of paramount importance to the community and City of San Diego. Therefore, the proposed project will conform with the certified Local Coastal Program land use plan and complies with all regulations of the certified Implementation Program.

4. For every Coastal Development Permit issued for any coastal development between the nearest public road and the sea or the shoreline of any body of water located within the Coastal Overlay Zone the coastal development is in conformity with the public access and public recreation policies of Chapter 3 of the California Coastal Act. The proposed project will improve the public safety within the public right-of-way along Torrey Pines Road between Little Street and Roseland Drive by installing an approximately 334 foot long, approximately twenty-seven foot high soil-nails retaining wall. The Torrey Pines Slope Restoration project includes excavation at the toe of the existing slope to achieve the required space for a sidewalk, removal of sloughing soil and debris off the existing slope face, and installation of a permanent soil-nails wall with an outer boulder-scape or rock carved surface. Several of the excavated slopes along the existing Torrey Pines Road were sprayed with gunite, a building material consisting of a mixture of cement, sand, and water that is sprayed into place. Gunite has little or no structural strength in that the mixture has no rock and no steel and is generally very thinly applied. Gunite has been used on slopes to prevent erosion of steep slopes. Gunite has no structural properties and is simply a thinly applied mixture of water, cement and sand. The existing condition presents a public safety concern. During intense storm events eroded material collects in the east-bound travel lane closest to the curb. A complete failure of the slope is possible.

The soil-nails wall would be approximately twenty-seven feet in height and approximately 334 feet in length. The soil-nails, up to forty feet in length, would be installed into the slope at an angle of approximately fifteen degrees below horizontal. The horizontal and vertical spaces of the soil-nails would be approximately six feet. Approximately 250 soil-nails would be used to construct a permanent wall. A permanent safety railing would be installed atop the soil-nails wall measuring forty-four inches high. A concrete brow ditch would be installed behind the soil-nails wall to intercept drainage from above and carry the stormwater runoff away from the soil-nails wall. A geocomposite drain system and weep holes would be integrated into the construction to eliminate hydrostatic pressure from building up behind the soil-nails wall. The proposed project will replace the existing gunite on the slope face with a soil-nails retaining wall and improve the safety of the transportation corridor. Therefore, the coastal development is in conformity with the public access and public recreation policies of Chapter 3 of the California Coastal Act.

Site Development Permit - Section 126.0504

- 1. The proposed development will not adversely affect the applicable land use plan.** The proposed project will improve the public safety within the public right-of-way along Torrey Pines Road between Little Street and Roseland Drive by installing an approximately 334 foot long, approximately twenty-

four foot high soil-nails retaining wall. The Torrey Pines Slope Restoration project includes excavation at the toe of the existing slope to achieve the required space for a sidewalk, removal of sloughing soil and debris off the existing slope face, and installation of a permanent soil-nails wall with an outer boulder-scape or rock carved surface. Several of the excavated slopes along the existing Torrey Pines Road were sprayed with gunite, a building material consisting of a mixture of cement, sand, and water that is sprayed into place. Gunite has little or no structural strength in that the mixture has no rock and no steel and is generally very thinly applied. Gunite has been used on slopes to prevent erosion of steep slopes. Gunite has no structural properties and is simply a thinly applied mixture of water, cement and sand. The existing condition presents a public safety concern. During intense storm events eroded material collects in the east-bound travel lane closest to the curb. A complete failure of the slope is possible.

The soil-nails wall would be approximately twenty-seven feet in height and approximately 334 feet in length. The soil-nails, up to forty feet in length, would be installed into the slope at an angle of approximately fifteen degrees below horizontal. The horizontal and vertical spaces of the soil-nails would be approximately six feet. Approximately 250 soil-nails would be used to construct a permanent wall. A permanent safety railing would be installed atop the soil-nails wall measuring forty-four inches high. A concrete brow ditch would be installed behind the soil-nails wall to intercept drainage from above and carry the stormwater runoff away from the soil-nails wall. A geocomposite drain system and weep holes would be integrated into the construction to eliminate hydrostatic pressure from building up behind the soil-nails wall. The proposed project will replace the existing gunite on the slope face with a soil-nails retaining wall and improve the safety of the transportation corridor.

The proposed project will be consistent with the transportation goals of the La Jolla Community Plan. The proposed project will replace the existing gunite on the slope face with a soil-nails retaining wall and improve the safety of the transportation corridor. Torrey Pines Road is an integral link in the Transportation Element and is a circulation element roadway. Safety of persons, vehicles and cargo is of paramount importance to the community and City of San Diego. Therefore, the proposed project will improve the safety of the roadway and will not adversely affect the La Jolla Community Plan or the goals contained therein.

2. **The proposed development will not be detrimental to the public health, safety, and welfare.** The proposed project will improve the public safety within the public right-of-way along Torrey Pines Road between Little Street and Roseland Drive by installing an approximately 334 foot long, approximately twenty-seven foot high soil-nails retaining wall. The Torrey Pines Slope Restoration project includes excavation at the toe of the existing slope to achieve the required space for a sidewalk, removal of sloughing soil and debris off the existing slope face, and installation of a permanent soil-nails wall with an outer boulder-scape or rock carved surface. Several of the excavated slopes along the existing Torrey Pines Road were sprayed with gunite, a building material consisting of a mixture of cement, sand, and water that is sprayed into place. Gunite has little or no structural strength in that the mixture has no rock and no steel and is generally very thinly applied. Gunite has been used on slopes to prevent erosion of steep slopes. Gunite has no structural properties and is simply a thinly applied mixture of water, cement and sand. The existing condition presents a public safety concern. During intense storm events eroded material collects in the east-bound travel lane closest to the curb. A complete failure of the slope is possible.

The soil-nails wall would be approximately twenty-seven feet in height and approximately 334 feet in length. The soil-nails, up to forty feet in length, would be installed into the slope at an angle of approximately fifteen degrees below horizontal. The horizontal and vertical spaces of the soil-nails would be approximately six feet. Approximately 250 soil-nails would be used to construct a permanent wall. A permanent safety railing would be installed atop the soil-nails wall measuring forty-four inches high. A concrete brow ditch would be installed behind the soil-nails wall to intercept drainage from above and carry the stormwater runoff away from the soil-nails wall. A geocomposite drain system and weep holes would be integrated into the construction to eliminate hydrostatic pressure from building up behind the soil-nails wall. The proposed project will replace the existing gunite on the slope face with a soil-nails retaining wall and improve the safety of the transportation corridor. Therefore, the proposed project will improve the public safety, and will not be detrimental to the public health, safety, and welfare.

3. The proposed development will comply with the applicable regulations of the Land

Development Code. The proposed project will improve the public safety within the public right-of-way along Torrey Pines Road between Little Street and Roseland Drive by installing an approximately 334 foot long, approximately twenty-seven foot high soil-nails retaining wall. The Torrey Pines Slope Restoration project includes excavation at the toe of the existing slope to achieve the required space for a sidewalk, removal of sloughing soil and debris off the existing slope face, and installation of a permanent soil-nails wall with an outer boulder-scape or rock carved surface. Several of the excavated slopes along the existing Torrey Pines Road were sprayed with gunite, a building material consisting of a mixture of cement, sand, and water that is sprayed into place. Gunite has little or no structural strength in that the mixture has no rock and no steel and is generally very thinly applied. Gunite has been used on slopes to prevent erosion of steep slopes. Gunite has no structural properties and is simply a thinly applied mixture of water, cement and sand. The existing condition presents a public safety concern. During intense storm events eroded material collects in the east-bound travel lane closest to the curb. A complete failure of the slope is possible.

The soil-nails wall would be approximately twenty-seven feet in height and approximately 334 feet in length. The soil-nails, up to forty feet in length, would be installed into the slope at an angle of approximately fifteen degrees below horizontal. The horizontal and vertical spaces of the soil-nails would be approximately six feet. Approximately 250 soil-nails would be used to construct a permanent wall. A permanent safety railing would be installed atop the soil-nails wall measuring forty-four inches high. A concrete brow ditch would be installed behind the soil-nails wall to intercept drainage from above and carry the stormwater runoff away from the soil-nails wall. A geocomposite drain system and weep holes would be integrated into the construction to eliminate hydrostatic pressure from building up behind the soil-nails wall. The proposed project will replace the existing gunite on the slope face with a soil-nails retaining wall and improve the safety of the transportation corridor.

The Hearing Officer finds the structure and improvements for which the permit was applied does conform to the regulations contained within the La Jolla Shores Planned District. No deviations or variance is required to approve the proposed project. The proposed project will comply with all local, state and federal regulations. Therefore, the proposed development will comply with the applicable regulations of the Land Development Code.

BE IT FURTHER RESOLVED that, based on the findings hereinbefore adopted by the Hearing Officer, Coastal Development Permit No. 846963 and Site Development Permit No. 846964 is hereby GRANTED by the

Hearing Officer to the referenced Owner/Permittee, in the form, exhibits, terms and conditions as set forth in Permit Nos. 846963 and 846964, a copy of which is attached hereto and made a part hereof.

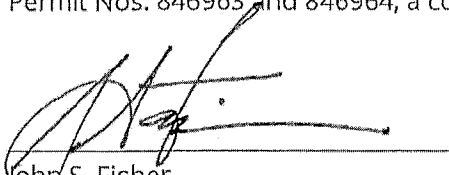

John S. Fisher
Development Project Manager
Development Services

Adopted on: November 9, 2016

Job Order No. WBS#-S-00877.02.06

APPENDIX P

SOIL NAIL EASEMENTS

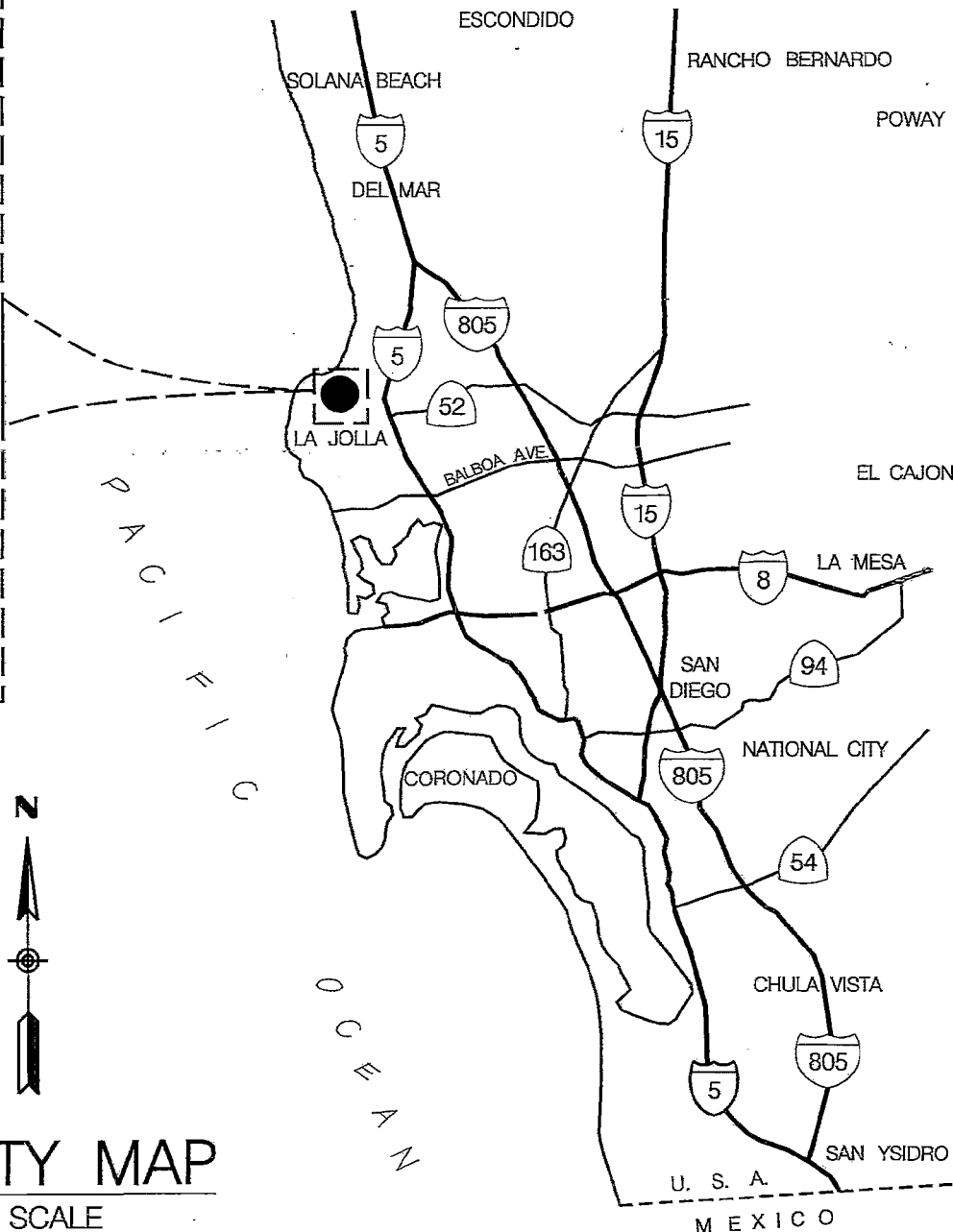
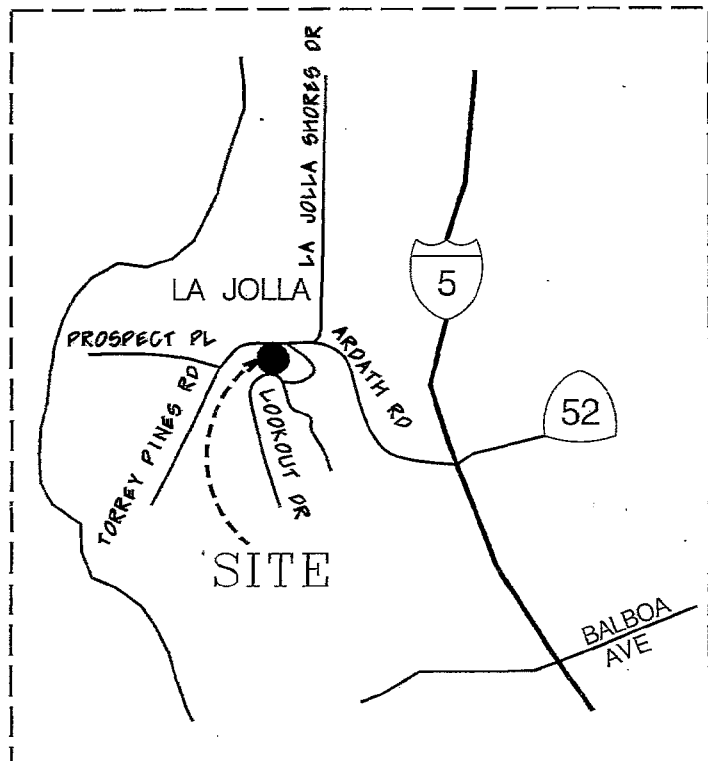

VICINITY MAP
NO SCALE

OWNER

ROBERT ARREND VAN HUIZUM

ASSESSOR PARCEL NUMBER

352-010-13

BASIS OF BEARINGS

The Basis of Bearing for this Survey is the grid bearing from City GPS Stations 167 and 253 per ROS 14492
IE: N 38°45'15" W

REFERENCES

CITY OF SAN DIEGO SURVEY FIELD NOTES
BY: RODGERS, 5/15/2002, W.O. 526740
L.C. 250-1689

CITY OF SAN DIEGO DWG. 4156-B, 4296-B, 18303-D

PREPARED BY:

THE CITY OF SAN DIEGO ENGINEERING DEPARTMENT
FIELD DIVISION - SURVEY SECTION, UNDER THE
DIRECTION OF RICHARD T. McCORMICK, LS 7450,
SENIOR LAND SURVEYOR

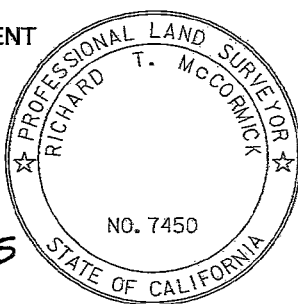

Richard T. McCormick 6-29-2015
RICHARD T. McCORMICK P.L.S. 7450 DATE

RESOLUTION No. _____

ADOPTED: _____

DOC. No. _____

RECORDED: _____

Soil Nail Easement
Lot 15 of La Jolla Hills Subdivision Map 1479

DESCRIPTION	BY	APPROVED	DATE	FILMED	CITY OF SAN DIEGO, CALIFORNIA	
ORIGINAL	MV	FRL	3/05		SHEET 1 OF 2 SHEETS	
REVISED	TM	RMc	2/15		T.M. _____ I.W.O. S-00877	
TITLE REVISION	TM	RMc	6/15		<i>Richard T. McCormick 6-29-2015</i> FOR CITY LAND SURVEYOR DATE	
AREA REVISION	TM	RMc	6/15		1890-6249 NAD83 COORDINATES	
STATUS					250-1689 NAD27 COORDINATES	
					20348-1-B	

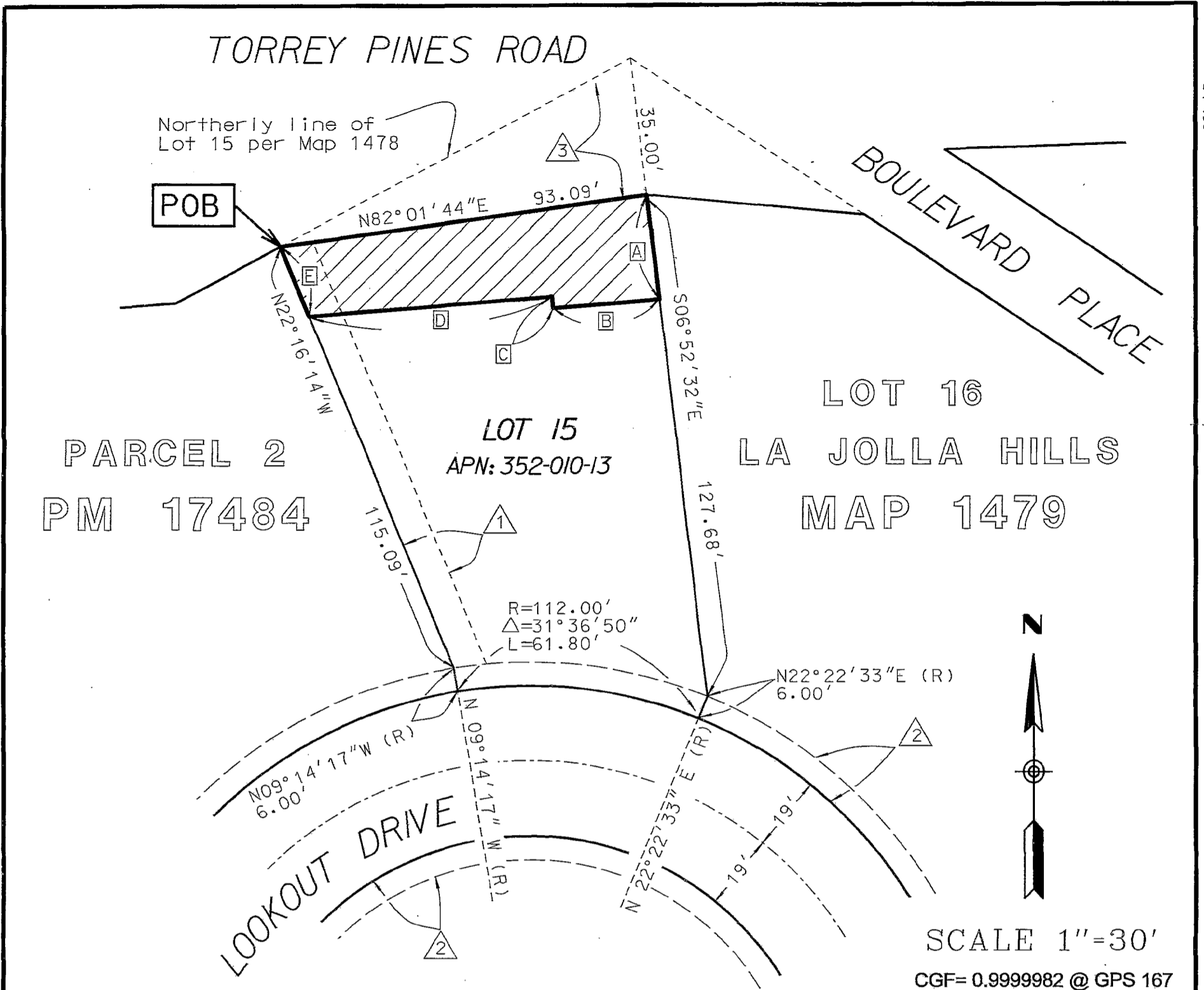

DEED REFERENCES

- ① 8' wide easement to SDG&E per deed recorded 5/13/1924 in Book 988/Page 475 of deeds O.R.
- ② 6' wide portion of Lookout Drive vacated by the City of San Diego Res. No. 222999 recorded 4/11/1979 as Doc. No. 79-148946 O.R. (City Dwg. 18303-D)
- ③ A portion of Torrey Pines Rd. dedicated per deed recorded 8/14/1951 in Book 4203/Page 74 O.R. (City Dwg. 4156-B & 4296-B)

LEGEND

- SOIL NAIL EASEMENT
AREA ACQUIRED =1981.30 SQ. FT.
0.0455 ACRES
- OVERLAP WITH ① =55.32 SQ. FT.
- POINT OF BEGINNING

DATA TABLE		
	BEARING	LENGTH
A	S 06°52'32" E	26.63'
B	S 85°22'06" W	26.97'
C	N 04°37'54" W	3.00'
D	S 85°22'06" W	61.23'
E	N 22°16'14" W	19.08'

**Soil Nail Easement
Lot 15 of La Jolla Hills Subdivision Map 1479**

DESCRIPTION	BY	APPROVED	DATE	FILMED	CITY OF SAN DIEGO, CALIFORNIA		T.M.
ORIGINAL	MV	FRL	3/05		SHEET 2 OF 2 SHEETS		I.W.O. S-00877
REVISED	TM	RMc	2/15				1890-6249
TITLE REVISION	TM	RMc	6/15		<i>Richard J. McQuinn</i>	6-29-2015	NAD83 COORDINATES
AREA REVISION	TM	RMc	6/15		FOR CITY LAND SURVEYOR	DATE	250-1689
							NAD27 COORDINATES
							20348-2-B
STATUS							

EXHIBIT "A"

Soil Nail Easement

APN: 352-010-13

That portion of Lot 15, of La Jolla Hills Subdivision, according to the Map thereof No. 1479, in the City of San Diego, County of San Diego, State of California, filed in the Office of the County Recorder of said San Diego County on October 10, 1912, being more particularly described as follows:

Beginning at the most northwesterly corner of said Lot 15, said point also being the most northeasterly corner of Parcel 2, according to Parcel Map 17484, filed in the said Office of the County Recorder on February 9, 1995; Thence leaving the northerly line of said Lot 15 North 82°01'44" East 93.09 feet along the southerly right of way of Torrey Pines Road as dedicated per deed recorded August 14, 1951 in Book 4203 Page 74 of Official Records to a point on the easterly line of said Lot 15; Thence leaving the said southerly right of way of Torrey Pines Road and continuing along the said easterly line of Lot 15 South 06°52'32" East 26.63 feet; Thence leaving the said easterly line South 85°22'06" West 26.97 feet; Thence North 04°37'54" West 3.00 feet; Thence South 85°22'06" West 61.23 feet to a point on the westerly line of said Lot 15; Thence along the said westerly line of Lot 15 North 22°16'14" West 19.08 feet to the **Point of Beginning**.

The above described Soil Nail Easement contains 1981.30 Square Feet, 0.0455 Acres.

Exhibit "B" (City of San Diego Drawing No. 20348-B), attached and by this reference is made a part hereto.

Richard T. McCormick 6-29-2015
Richard T. McCormick LS 7450 Date
Senior Land Surveyor, Field Engineering
My Registration Expires 12-31-2016

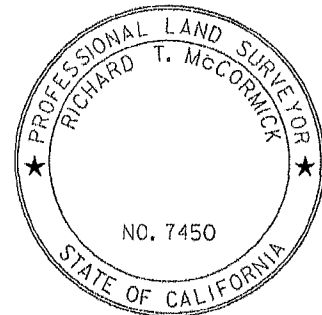

File: APN 352-010-13 legal_areaREV.docx
WBS S-00877.01.01-June 2015

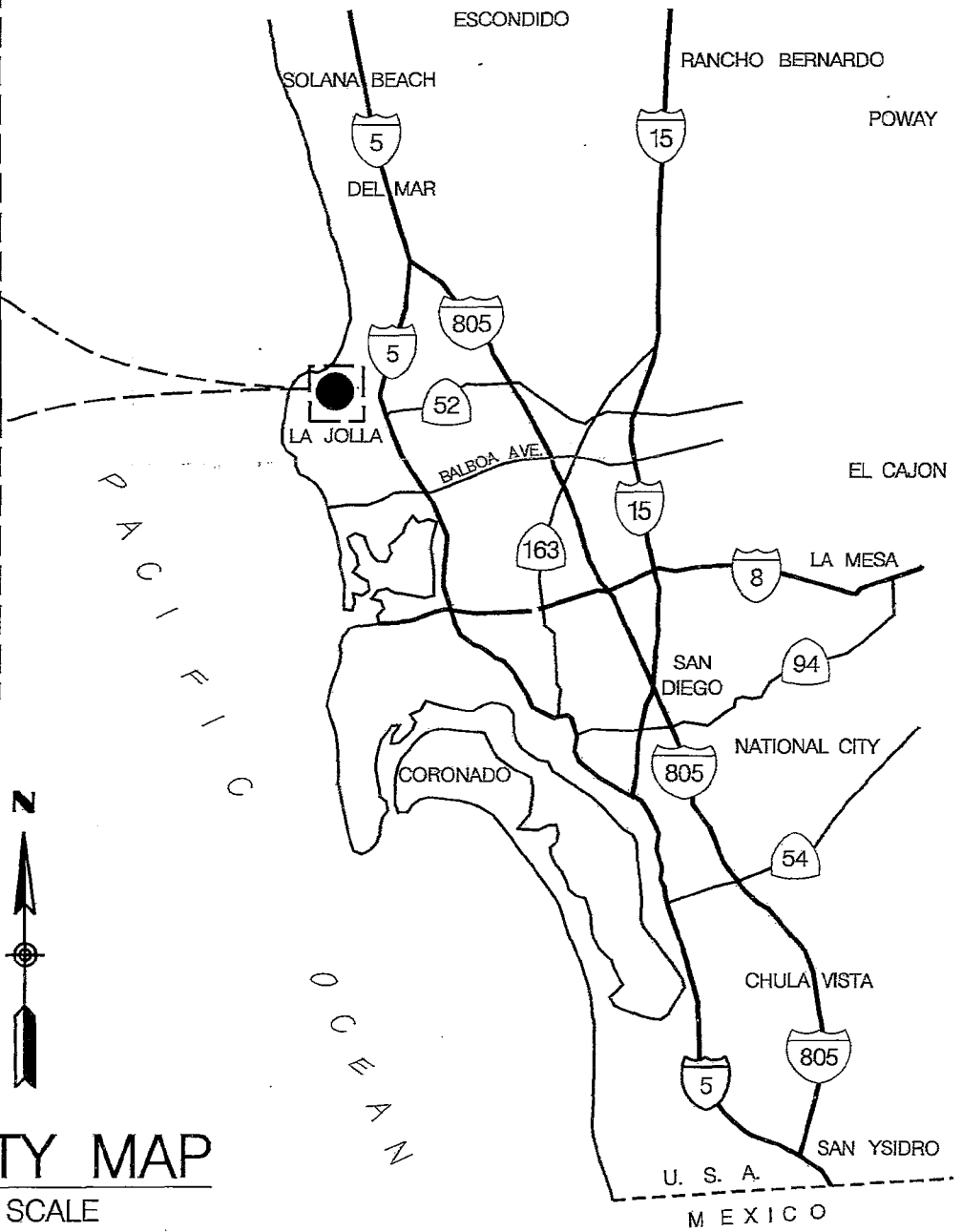
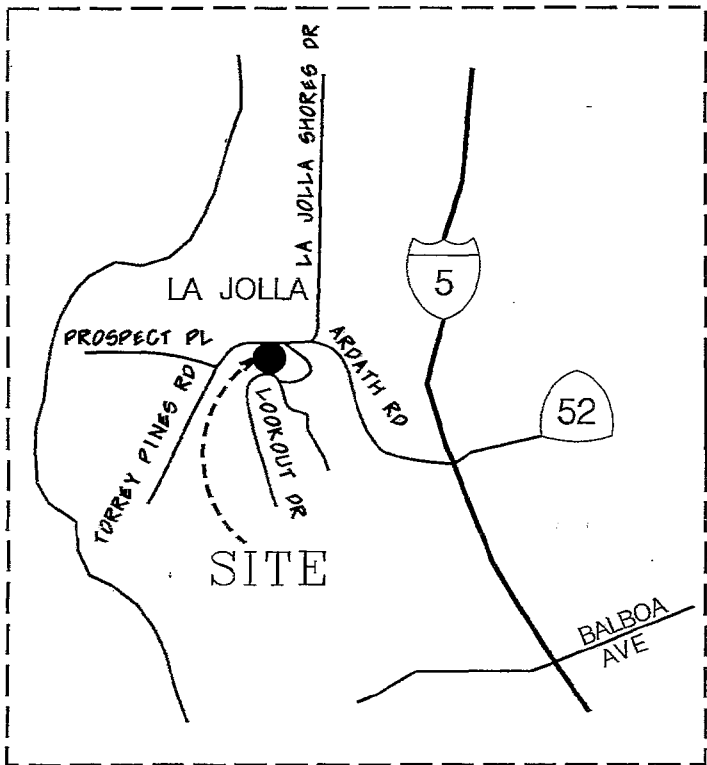

VICINITY MAP
NO SCALE

OWNER

DAVID W HILL, TRUSTEE

ASSESSOR PARCEL NUMBER

352-010-14

BASIS OF BEARINGS

The Basis of Bearing for this Survey is the grid bearing from City GPS Stations 167 and 253 per ROS 14492
IE: N 38°45'15" W

REFERENCES

CITY OF SAN DIEGO SURVEY FIELD NOTES
BY: RODGERS, 5/15/2002, W.O. 526740
L.C. 250-1689

CITY OF SAN DIEGO DWG. 4156-B, 4296-B, 18303-D

PREPARED BY:

THE CITY OF SAN DIEGO ENGINEERING DEPARTMENT
FIELD DIVISION - SURVEY SECTION, UNDER THE
DIRECTION OF RICHARD T. McCORMICK, LS 7450,
SENIOR LAND SURVEYOR

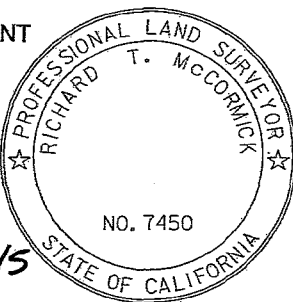

Richard T. McCormick 6-29-2015
RICHARD T. McCORMICK P.L.S. 7450 DATE

RESOLUTION No. _____

ADOPTED: _____

DOC. No. _____

RECORDED: _____

Soil Nail Easement
Lot 16 of La Jolla Hills Subdivision Map 1479

DESCRIPTION	BY	APPROVED	DATE	FILMED	CITY OF SAN DIEGO, CALIFORNIA	
ORIGINAL	MV	FRL	3/05		SHEET 1 OF 2 SHEETS	
REVISED	TM	RMc	2/15		T.M. _____ I.W.O. S-00877	
TITLE REVISION	TM	RMc	6/15		<i>Richard T. McCormick</i> 6-29-2015 FOR CITY LAND SURVEYOR DATE	
AREA REVISION	TM	RMc	6/15		1890-6249 NAD83 COORDINATES	
					250-1689 NAD27 COORDINATES	
					20349-1-B	
STATUS						

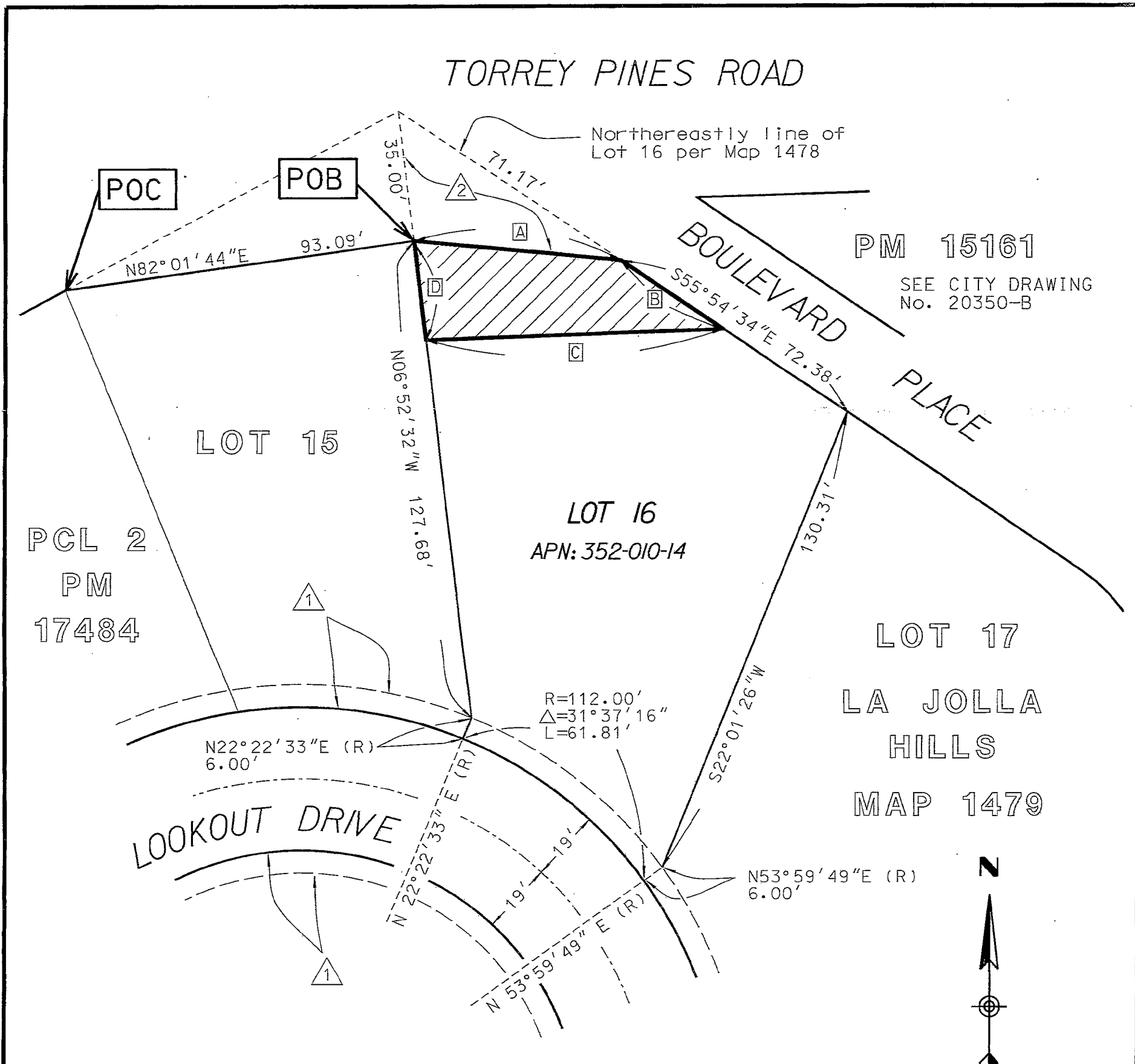

PM 15161
SEE CITY DRAWING
No. 20350-B

PCL 2
PM
17484

LOT 16
APN: 352-010-14

LOT 17
LA JOLLA
HILLS
MAP 1479

DEED REFERENCES

- ① 6' wide portion of Lookout Drive vacated by the City of San Diego Res. No. 222999 recorded 4/11/1979 as Doc. No. 79-148946 O.R. (City Dwg. 18303-D)
- ② A portion of Torrey Pines Rd. dedicated per deed recorded 8/14/1951 in Book 4203/Page 68 O.R. (City Dwg. 4156-B & 4296-B)

LEGEND

- SOIL NAIL EASEMENT
AREA ACQUIRED = 1479.79 SQ. FT.
0.0340 ACRES
- POB** POINT OF BEGINNING
- POC** POINT OF COMMENCEMENT

DATA TABLE

	BEARING	LENGTH
A	S 84° 38' 03" E	54.99'
B	S 55° 54' 34" E	32.85'
C	S 87° 54' 17" W	78.82'
D	N 06° 52' 32" W	26.63'

**Soil Nail Easement
Lot 16 of La Jolla Hills Subdivision Map 1479**

DESCRIPTION	BY	APPROVED	DATE	FILMED	CITY OF SAN DIEGO, CALIFORNIA SHEET 2 OF 2 SHEETS <i>Richard J. Morrison</i> 6-29-2015 FOR CITY LAND SURVEYOR DATE	T.M.	
ORIGINAL	MV	FRL	3/05			I.W.O.	S-00877
REVISED	TM	RMc	2/15				1890-6249
TITLE REVISION	TM	RMc	6/15				NAD83 COORDINATES
AREA REVISION	TM	RMc	6/15				250-1689
STATUS							NAD27 COORDINATES
							20349-2-B

EXHIBIT "A"

Soil Nail Easement

APN: 352-010-14

That portion of Lot 16, of La Jolla Hills Subdivision, according to the Map thereof No. 1479, in the City of San Diego, County of San Diego, State of California, filed in the Office of the County Recorder of said San Diego County on October 10, 1912, being more particularly described as follows:

Commencing at the most northwesterly corner of Lot 15 of said Map 1479, said point also being the most northeasterly corner of Parcel 2, according to Parcel Map 17484, filed in the said Office of the County Recorder on February 9, 1995; Thence leaving the northerly line of said Lot 15, North 82°01'44" East 93.09 feet along the southerly right of way of Torrey Pines Road as dedicated per deed recorded August 14, 1951 in Book 4203 Page 74 of Official Records to a point on the westerly line of said Lot 16, said point being the **Point of Beginning**; Thence leaving the said westerly line of Lot 16 South 84°38'03" East 54.99 feet to a point on the northeasterly line of said Lot 16; Thence leaving the said southerly right of way of Torrey Pines Road and continuing along the said northeasterly line of Lot 16 South 55°54'34" East 32.85 feet; Thence leaving the said northeasterly line of Lot 16 South 87°54'17" West 78.82 feet to a point on the said westerly line of Lot 16; Thence along the said westerly line of Lot 16 North 06°52'32" West 26.63 feet to the **Point of Beginning**.

The above described Soil Nail Easement contains 1479.79 Square Feet, 0.0340 Acres.

Exhibit "B" (City of San Diego Drawing No. 20349-B), attached and by this reference is made a part hereto.

 6-29-2015
Richard T. McCormick LS 7450 Date
Senior Land Surveyor, Field Engineering
My Registration Expires 12-31-2016

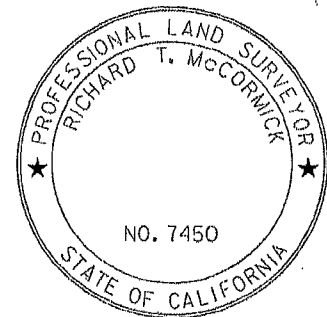

File: APN 352-010-14 legal_areaREV.docx
WBS S-00877.01.01-June 2015

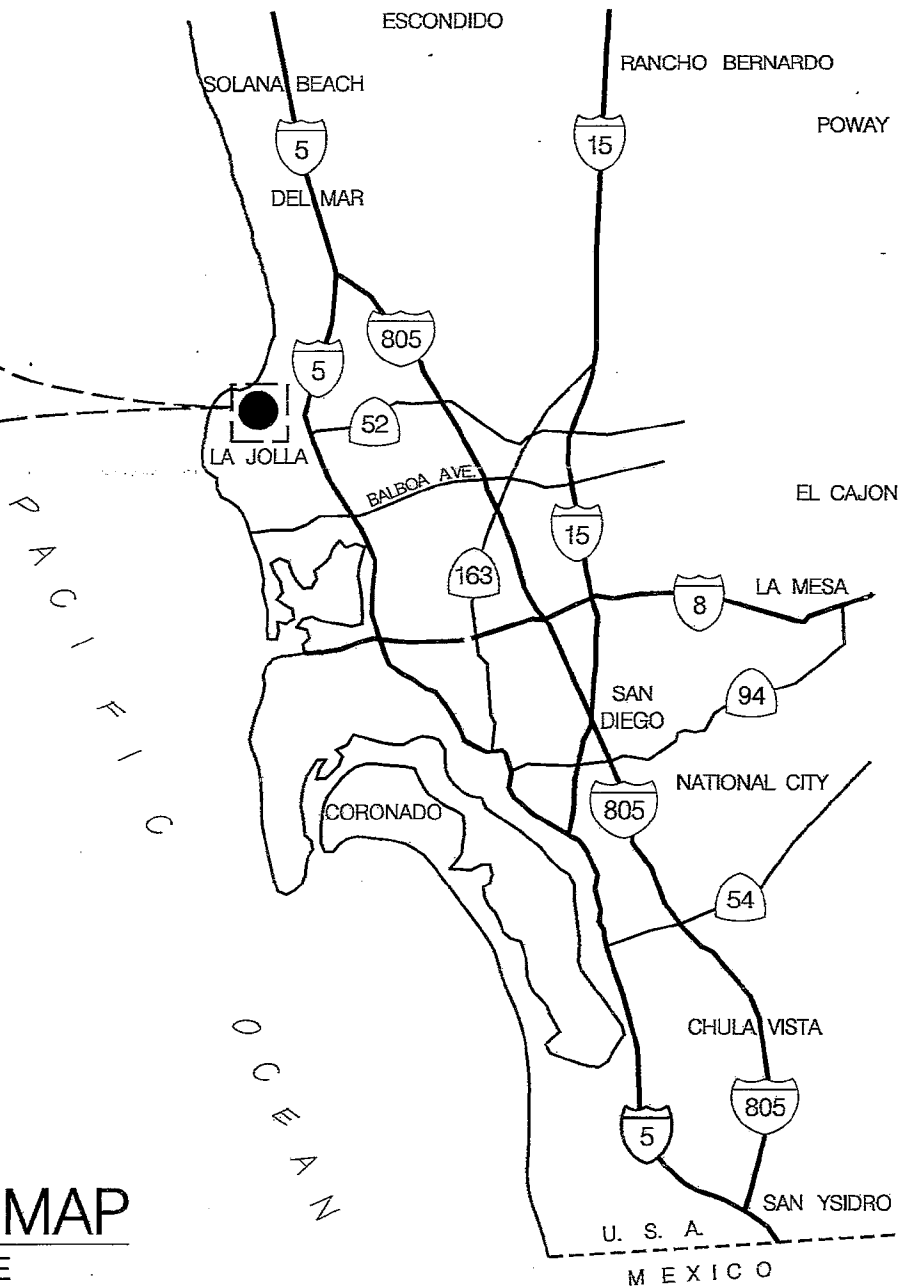
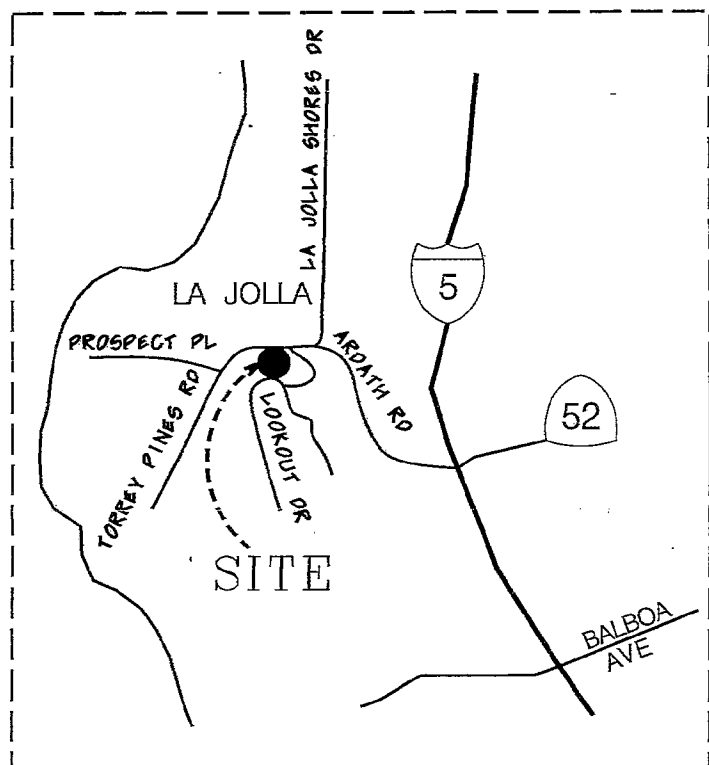

VICINITY MAP
NO SCALE

OWNER

CITY OF SAN DIEGO, A MUNICIPAL CORPORATION

ASSESSOR PARCEL NUMBER

346-484-07

BASIS OF BEARINGS

The Basis of Bearing for this Survey is the grid bearing from City GPS Stations 167 and 253 per ROS 14492
IE: N 38°45'15" W

REFERENCES

CITY OF SAN DIEGO SURVEY FIELD NOTES
BY: RODGERS, 5/15/2002, W.O. 526740
L.C. 250-1689

CITY OF SAN DIEGO DWG. 4156-B, 4296-B, 18303-D

PREPARED BY:

THE CITY OF SAN DIEGO ENGINEERING DEPARTMENT
FIELD DIVISION - SURVEY SECTION, UNDER THE
DIRECTION OF RICHARD T. McCORMICK, LS 7450,
SENIOR LAND SURVEYOR

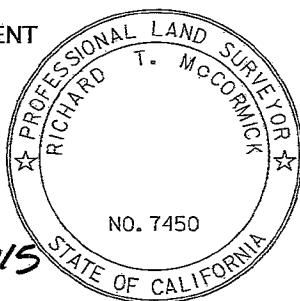

Richard T. McCormick 6-29-2015

RICHARD T. McCORMICK P.L.S. 7450 DATE

RESOLUTION No. _____

ADOPTED: _____

DOC. No. _____

RECORDED: _____

**Set-Aside Soil Nail Easement
Parcel 1 of Parcel Map 15161**

DESCRIPTION	BY	APPROVED	DATE	FILMED	CITY OF SAN DIEGO, CALIFORNIA	T.M.
ORIGINAL	MV	FRL	3/05		SHEET 1 OF 2 SHEETS	I.W.O. S-00877
REVISED	TM	RMc	2/15			
TITLE REVISION	TM	RMc	6/15		<i>Richard T. McCormick 6-29-2015</i>	1890-6249
AREA REVISION	TM	RMc	6/15		FOR CITY LAND SURVEYOR DATE	NAD83 COORDINATES
						250-1689
						NAD27 COORDINATES
						20350-1-B
STATUS						

DATA TABLE	
BEARING	LENGTH
A N 87°39'53" E	117.31'
(N 87°10'11" E	117.31')
B S 65°20'34" E	37.20'
C S 05°58'00" W	27.00'
D N 86°52'08" W	100.97'
E N 55°54'34" W	57.22'

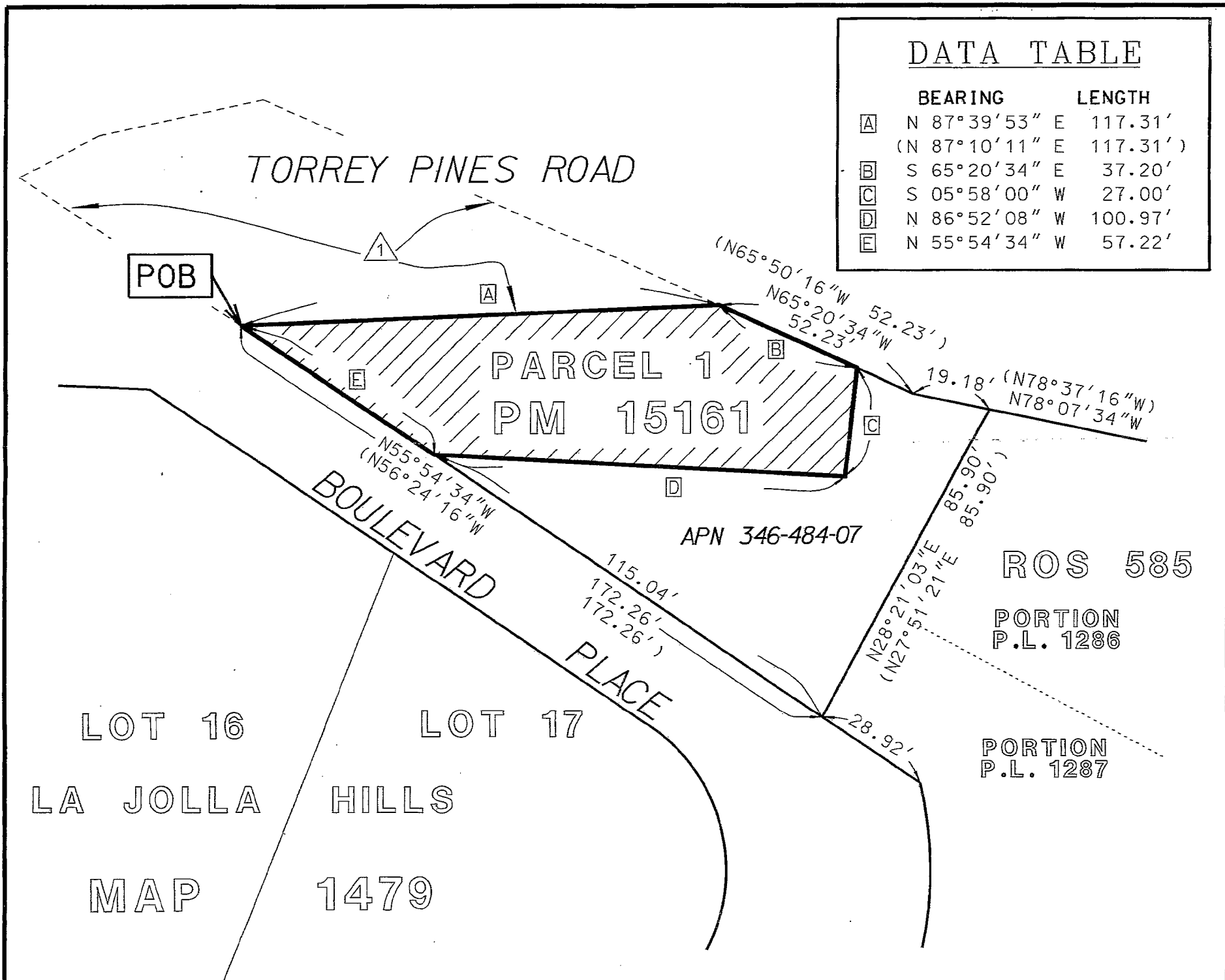

DEED REFERENCES

△ A portion of Torrey Pines Rd. dedicated per deed recorded 10/29/1951 in Book 4275/Page 378 O.R. (City Dwg. 4156-B & 4296-B)

LEGEND

SET-ASIDE SOIL NAIL EASEMENT
AREA ACQUIRED = 4518.89 SQ. FT.
0.1037 ACRES

POINT OF BEGINNING
() RECORD DATA PER PM 15161

SCALE 1"=30'
CGF= 0.9999982 @ GPS 167
Mapping Angle= -0° 29' 35.8"
Elevation= 301.13 (NGVD29)

**Set-Aside Soil Nail Easement
Parcel 1 of Parcel Map 15161**

DESCRIPTION	BY	APPROVED	DATE	FILMED	CITY OF SAN DIEGO, CALIFORNIA	
ORIGINAL	MV	FRL	3/05		SHEET 2 OF 2 SHEETS	
REVISED	TM	RMc	2/15		T.M. _____ I.W.O. S-00877	
TITLE REVISION	TM	RMc	6/15		1890-6249 NAD83 COORDINATES	
AREA REVISION	TM	RMc	6/15		250-1689 NAD27 COORDINATES	
STATUS					20350-2-B	

EXHIBIT "A"

Set-Aside Soil Nail Easement

APN: 346-484-07

That portion of Parcel 1, according to the Parcel Map thereof No. 15161, in the City of San Diego, County of San Diego, State of California, filed in the Office of the County Recorder of said San Diego County on February 26, 1988, being more particularly described as follows:

Beginning at the northwest corner of said Parcel 1; Thence along the northerly line of said Parcel 1 North $87^{\circ}39'53''$ East 117.31 feet to the northeasterly corner thereof; Thence South $65^{\circ}20'34''$ East 37.20 feet along the northeasterly line of said Parcel 1; Thence leaving the said northeasterly line of Parcel 1 South $05^{\circ}58'00''$ West 27.00 feet; Thence North $86^{\circ}52'08''$ West 100.97 feet to a point on the southwesterly line of said Parcel 1; Thence along the said southwesterly line of said Parcel 1 North $55^{\circ}54'34''$ West 57.22 feet to the **Point of Beginning**.

The above described Set-Aside Soil Nail Easement contains 4518.89 Square Feet, 0.1037 Acres.

Exhibit "B" (City of San Diego Drawing No. 20350-B), attached and by this reference is made a part hereto.

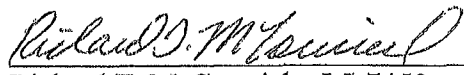
 6-29-2015
Richard T. McCormick LS 7450 Date
Senior Land Surveyor, Field Engineering
My Registration Expires 12-31-2016

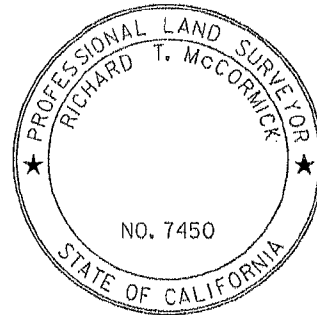

File: APN 346-484-07 legal_areaREV.docx
WBS S-00877.01.01-June 2015

ATTACHMENT F
INTENTIONALLY LEFT BLANK

ATTACHMENT G

CONTRACT AGREEMENT



CONTRACT AGREEMENT

CONSTRUCTION CONTRACT

This contract is made and entered into between THE CITY OF SAN DIEGO, a municipal corporation, herein called "City" and Hazard Construction Company, herein called "Contractor" for for construction of **Torrey Pines Road Improvements Phase 2 and Torrey Pines Road Slope Restoration**; Bid No. **K-18-1550-DBB-3**; in the amount of Two Million Six Hundred Ninety Two Thousand Two Hundred Thirty Five Dollars and Zero Cents (\$2,692,235.00), which is comprised of the Base Bid.

IN CONSIDERATION of the payments to be made hereunder and the mutual undertakings of the parties hereto, City and Contractor agree as follows:

1. The following are incorporated into this contract as though fully set forth herein:
 - (a) The attached Faithful Performance and Payment Bonds.
 - (b) The attached Proposal included in the Bid documents by the Contractor.
 - (c) Reference Standards listed in the Instruction to Bidders and the Supplementary Special Provisions (SSP).
 - (d) That certain documents entitled **Torrey Pines Road Improvements Phase 2 and Torrey Pines Road Slope Restoration**, on file in the office of the Public Works Department as Document No. **S-15023, S-00877, and B-18014**, as well as all matters referenced therein.
2. The Contractor shall perform and be bound by all the terms and conditions of this contract and in strict conformity therewith shall perform and complete in a good and workmanlike manner **Torrey Pines Road Improvements Phase 2 and Torrey Pines Road Slope Restoration**, Bid Number **K-18-1550-DBB-3**, San Diego, California.
3. For such performances, the City shall pay to Contractor the amounts set forth at the times and in the manner and with such additions or deductions as are provided for in this contract, and the Contractor shall accept such payment in full satisfaction of all claims incident to such performances.
4. No claim or suit whatsoever shall be made or brought by Contractor against any officer, agent, or employee of the City for or on account of anything done or omitted to be done in connection with this contract, nor shall any such officer, agent, or employee be liable hereunder.
5. This contract is effective as of the date that the Mayor or designee signs the agreement.

CONTRACT AGREEMENT (continued)

IN WITNESS WHEREOF, this Agreement is signed by the City of San Diego, acting by and through its Mayor or designee, pursuant to Municipal Code §22.3102 authorizing such execution.

THE CITY OF SAN DIEGO

APPROVED AS TO FORM

By 

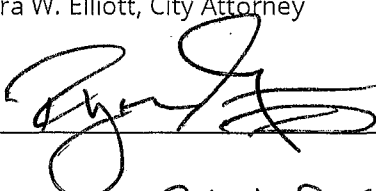
Mara W. Elliott, City Attorney
By 

Print Name: Stephen Samara
Principal Contract Specialist
Public Works Department

Print Name: RYAN P. GERRITY
Deputy City Attorney

Date: 1-12-2018

Date: 1/16/18

CONTRACTOR **HAZARD CONSTRUCTION COMPANY**

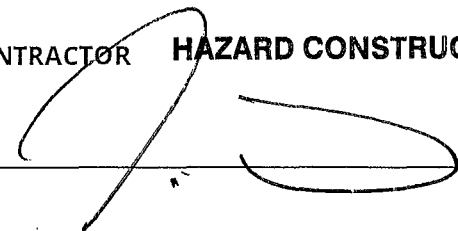
By 

Print Name: _____

Title: JASON A. MORDHORST, PRESIDENT

Date: 11/17/17

City of San Diego License No.: B1998008961

State Contractor's License No.: 750542

DEPARTMENT OF INDUSTRIAL RELATIONS (DIR) REGISTRATION NUMBER: 1000022121

CERTIFICATIONS AND FORMS

The Bidder, by submitting its electronic bid, agrees to and certifies under penalty of perjury under the laws of the State of California, that the certifications, forms and affidavits submitted as part of this bid are true and correct.

Bidder's General Information

To the City of San Diego:

Pursuant to "Notice Inviting Bids", specifications, and requirements on file with the City Clerk, and subject to all provisions of the Charter and Ordinances of the City of San Diego and applicable laws and regulations of the United States and the State of California, the undersigned hereby proposes to furnish to the City of San Diego, complete at the prices stated herein, the items or services hereinafter mentioned. The undersigned further warrants that this bid is not made in the interest of, or on behalf of, any undisclosed person, partnership, company, association, organization, or corporation; that the bid is genuine and not collusive or sham; that the bidder has not directly or indirectly induced or solicited any other bidder to put in a false or sham bid, and has not directly or indirectly colluded, conspired, connived, or agreed with any bidder or anyone else to put in a sham bid, or that anyone shall refrain from bidding; that the bidder has not in any manner, directly or indirectly, sought by agreement, communication, or conference with anyone to fix the bid price of the bidder or any other bidder, or to fix any overhead, profit, or cost element of the bid price, or of that of any other bidder, or to secure any advantage against the public body awarding the contract of anyone interested in the proposed contract; that all statements contained in the bid are true; and, further, that the bidder has not, directly or indirectly, submitted his or her bid price or any breakdown thereof, or the contents thereof, or divulged information or data relative thereto, or paid, and will not pay, any fee to any corporation, partnership, company, association, organization, bid depository, or to any member or agent thereof to effectuate a collusive or sham bid.

The undersigned bidder(s) further warrants that bidder(s) has thoroughly examined and understands the entire Contract Documents (plans and specifications) and the Bidding Documents therefore, and that by submitting said Bidding Documents as its bid proposal, bidder(s) acknowledges and is bound by the entire Contract Documents, including any addenda issued thereto, as such Contract Documents incorporated by reference in the Bidding Documents.

**NON-COLLUSION AFFIDAVIT TO BE EXECUTED BY BIDDER AND SUBMITTED WITH BID UNDER 23
UNITED STATES CODE 112 AND PUBLIC CONTRACT CODE 7106**

State of California

County of San Diego

The bidder, being first duly sworn, deposes and says that he or she is authorized by the party making the foregoing bid that the bid is not made in the interest of, or on behalf of, any undisclosed person, partnership, company, association, organization, or corporation; that the bid is genuine and not collusive or sham; that the bidder has not directly or indirectly induced or solicited any other bidder to put in a false or sham bid, and has not directly or indirectly colluded, conspired, connived, or agreed with any bidder or anyone else to put in a sham bid, or that anyone shall refrain from bidding; that the bidder has not in any manner, directly or indirectly, sought by agreement, communication, or conference with anyone to fix the bid price of the bidder or any other bidder, or to fix any overhead, profit, or cost element of the bid price, or of that of any other bidder, or to secure any advantage against the public body awarding the contract of anyone interested in the proposed contract; that all statements contained in the bid are true; and further, that the bidder has not, directly or indirectly, submitted his or her bid price or any breakdown thereof, or the contents thereof, or divulged information or data relative thereto, or paid, and will not pay, any fee to any corporation, partnership, company association, organization, bid depository, or to any member or agent thereof to effectuate a collusive or sham bid.

CONTRACTOR CERTIFICATION

DRUG-FREE WORKPLACE

I hereby certify that I am familiar with the requirements of San Diego City Council Policy No. 100-17 regarding Drug-Free Workplace as outlined in the WHITEBOOK, Section 7-13.3, "Drug-Free Workplace", of the project specifications, and that;

This company_has in place a drug-free workplace program that complies with said policy. I further certify that each subcontract agreement for this project contains language which indicates the subcontractor's agreement to abide by the provisions of subdivisions a) through c) of the policy as outlined.

CONTRACTOR CERTIFICATION

AMERICAN WITH DISABILITIES ACT (ADA) COMPLIANCE CERTIFICATION

I hereby certify that I am familiar with the requirements of San Diego City Council Policy No. 100-4 regarding the American With Disabilities Act (ADA) outlined in the WHITEBOOK, Section 7-13.2, "American With Disabilities Act", of the project specifications, and that:

This company has in place workplace program that complies with said policy. I further certify that each subcontract agreement for this project contains language which indicates the subcontractor's agreement to abide by the provisions of the policy as outlined.

CONTRACTOR CERTIFICATION

CONTRACTOR STANDARDS - PLEDGE OF COMPLIANCE

I declare under penalty of perjury that I am authorized to make this certification on behalf of the company submitting this bid/proposal, that as Contractor, I am familiar with the requirements of City of San Diego Municipal Code § 22.3004 regarding Contractor Standards as outlined in the WHITEBOOK, Section 7-13.4, ("Contractor Standards"), of the project specifications, and that Contractor has complied with those requirements.

I further certify that each of the Contractor's subcontractors whose subcontracts are greater than \$50,000 in value has completed a Pledge of Compliance attesting under penalty of perjury of having complied with City of San Diego Municipal Code § 22.3004.

CONTRACTOR CERTIFICATION

Equal Benefits Ordinance Certification

I declare under penalty of perjury that I am familiar with the requirements of and in compliance with the City of San Diego Municipal Code § 22.4300 regarding Equal Benefits Ordinance

AFFIDAVIT OF DISPOSAL

(To be submitted upon completion of Construction pursuant to the contracts Certificate of Completion)

WHEREAS, on the _____ DAY OF _____, 2____, the undersigned entered into and executed a contract with the City of San Diego, a municipal corporation, for:

Torrey Pines Road Improvements Phase 2

(Name of Project or Task)

as particularly described in said contract and identified as Bid No. **K-18-1550-DBB-3**; SAP No. (WBS/IO/CC) **S-15023, S-00877, and B-18014**; and **WHEREAS**, the specification of said contract requires the Contractor to affirm that "all brush, trash, debris, and surplus materials resulting from this project have been disposed of in a legal manner"; and **WHEREAS**, said contract has been completed and all surplus materials disposed of:

NOW, THEREFORE, in consideration of the final payment by the City of San Diego to said Contractor under the terms of said contract, the undersigned Contractor, does hereby affirm that all surplus materials as described in said contract have been disposed of at the following location(s)

and that they have been disposed of according to all applicable laws and regulations.

Dated this _____ DAY OF _____, _____.

By: _____
Contractor

ATTEST:

State of _____ County of _____

On this _____ DAY OF _____, 2____, before the undersigned, a Notary Public in and for said County and State, duly commissioned and sworn, personally appeared _____ known to me to be the _____ Contractor named in the foregoing Release, and whose name is subscribed thereto, and acknowledged to me that said Contractor executed the said Release.

Notary Public in and for said County and State

LIST OF SUBCONTRACTORS

***** PROVIDED FOR ILLUSTRATIVE PURPOSES ONLY *** TO BE SUBMITTED IN ELECTRONIC FORMAT ONLY *** SEE INSTRUCTIONS TO BIDDERS, FOR FURTHER INFORMATION**

In accordance with the requirements of the "Subletting and Subcontracting Fair Practices Act", Section 4100, of the California Public Contract Code (PCC), the Bidder is to list below the name, address and license number of each Subcontractor who will perform work, labor, render services or specially fabricate and install a portion [type] of the work or improvement, in an amount of or in excess of 0.5% of the Contractor's total Bid. Failure to comply with this requirement may result in the Bid being rejected as non-responsive. The Contractor is to list only one Subcontractor for each portion of the Work. The Bidder's attention is directed to the Special Provisions - General; Paragraph 2-3 Subcontracts, which stipulates the percentage of the Work to be performed with the Bidder's own forces. The Bidder is to also list all SLBE, ELBE, DBE, DVBE, MBE, WBE, OBE, SDB, WoSB, HUBZone, and SDVOSB Subcontractors for which the Bidders are seeking recognition towards achieving any mandatory, voluntary, or both subcontracting participation percentages.

NAME, ADDRESS AND TELEPHONE NUMBER OF SUBCONTRACTOR	CONSTRUCTOR OR DESIGNER	SUBCONTRACTOR LICENSE NUMBER	TYPE OF WORK	DOLLAR VALUE OF SUBCONTRACT	MBE, WBE, DBE, DVBE, OBE, ELBE, SLBE, SDB, WoSB, HUBZone, OR SDVOSB	WHERE CERTIFIED	CHECK IF JOINT VENTURE PARTNERSHIP
Name: _____ Address: _____ City: _____ State: _____ Zip: _____ Phone: _____ Email: _____							
Name: _____ Address: _____ City: _____ State: _____ Zip: _____ Phone: _____ Email: _____							

- ① As appropriate, Bidder shall identify Subcontractor as one of the following and shall include a valid proof of certification (except for OBE, SLBE and ELBE):
- | | | | |
|---|--------|--|---------|
| Certified Minority Business Enterprise | MBE | Certified Woman Business Enterprise | WBE |
| Certified Disadvantaged Business Enterprise | DBE | Certified Disabled Veteran Business Enterprise | DVBE |
| Other Business Enterprise | OBE | Certified Emerging Local Business Enterprise | ELBE |
| Certified Small Local Business Enterprise | SLBE | Small Disadvantaged Business | SDB |
| Woman-Owned Small Business | WoSB | HUBZone Business | HUBZone |
| Service-Disabled Veteran Owned Small Business | SDVOSB | | |
- ② As appropriate, Bidder shall indicate if Subcontractor is certified by:
- | | | | |
|--|--------|--|----------|
| City of San Diego | CITY | State of California Department of Transportation | CALTRANS |
| California Public Utilities Commission | CPUC | | |
| State of California's Department of General Services | CADoGS | City of Los Angeles | LA |
| State of California | CA | U.S. Small Business Administration | SBA |

The Bidder will not receive any subcontracting participation percentages if the Bidder fails to submit the required proof of certification.

NAMED EQUIPMENT/MATERIAL SUPPLIER LIST

*** PROVIDED FOR ILLUSTRATIVE PURPOSES ONLY *** TO BE SUBMITTED IN ELECTRONIC FORMAT ONLY *** SEE INSTRUCTIONS TO BIDDERS FOR FURTHER INFORMATION

NAME, ADDRESS AND TELEPHONE NUMBER OF VENDOR/SUPPLIER	MATERIALS OR SUPPLIES	DOLLAR VALUE OF MATERIAL OR SUPPLIES	SUPPLIER (Yes/No)	MANUFACTURER (Yes/No)	MBE, WBE, DBE, DVBE, OBE, ELBE, SLBE, SDB, WoSB, HUBZone, OR SDVOSB ^①	WHERE CERTIFIED ^②
Name: _____ Address: _____ City: _____ State: _____ Zip: _____ Phone: _____ Email: _____						
Name: _____ Address: _____ City: _____ State: _____ Zip: _____ Phone: _____ Email: _____						

- ① As appropriate, Bidder shall identify Vendor/Supplier as one of the following and shall include a valid proof of certification (except for OBE,SLBE and ELBE):
- | | | | |
|---|--------|--|---------|
| Certified Minority Business Enterprise | MBE | Certified Woman Business Enterprise | WBE |
| Certified Disadvantaged Business Enterprise | DBE | Certified Disabled Veteran Business Enterprise | DVBE |
| Other Business Enterprise | OBE | Certified Emerging Local Business Enterprise | ELBE |
| Certified Small Local Business Enterprise | SLBE | Small Disadvantaged Business | SDB |
| Woman-Owned Small Business | WoSB | HUBZone Business | HUBZone |
| Service-Disabled Veteran Owned Small Business | SDVOSB | | |
- ② As appropriate, Bidder shall indicate if Vendor/Supplier is certified by:
- | | | | |
|--|--------|--|----------|
| City of San Diego | CITY | State of California Department of Transportation | CALTRANS |
| California Public Utilities Commission | CPUC | | |
| State of California's Department of General Services | CADoGS | City of Los Angeles | LA |
| State of California | CA | U.S. Small Business Administration | SBA |

The Bidder will not receive any subcontracting participation percentages if the Bidder fails to submit the required proof of certification.

ELECTRONICALLY SUBMITTED FORMS

THE FOLLOWING FORMS MUST BE SUBMITTED IN PDF FORMAT WITH BID SUBMISSION

The following forms are to be completed by the bidder and submitted (uploaded) electronically with the bid in PlanetBids.

- A. **BID BOND - See Instructions to Bidders, Bidders Guarantee of Good Faith (Bid Security) for further instructions**
- B. **CONTRACTOR'S CERTIFICATION OF PENDING ACTIONS**

Bids will not be accepted until ALL forms are submitted as part of the bid submittal

BID BOND

**See Instructions to Bidders, Bidder Guarantee of Good Faith
(Bid Security)**

KNOW ALL MEN BY THESE PRESENTS,

That HAZARD CONSTRUCTION COMPANY as Principal,
and Nationwide Mutual Insurance Company as Surety, are
held and firmly bound unto The City of San Diego hereinafter called "OWNER," in the sum of **10% OF
THE TOTAL BID AMOUNT** for the payment of which sum, well and truly to be made, we bind
ourselves, our heirs, executors, administrators, successors, and assigns, jointly and severally, firmly
by these presents.

WHEREAS, said Principal has submitted a Bid to said OWNER to perform the WORK required under
the bidding schedule(s) of the OWNER's Contract Documents entitled
Torrey Pines Road Improvements Phase 2 and Torrey Pines Road
Slope Restoration K-18-1550-DBB-3

NOW THEREFORE, if said Principal is awarded a contract by said OWNER and, within the time and in
the manner required in the "Notice Inviting Bids" enters into a written Agreement on the form of
agreement bound with said Contract Documents, furnishes the required certificates of insurance, and
furnishes the required Performance Bond and Payment Bond, then this obligation shall be null and
void, otherwise it shall remain in full force and effect. In the event suit is brought upon this bond by
said OWNER and OWNER prevails, said Surety shall pay all costs incurred by said OWNER in such suit,
including a reasonable attorney's fee to be fixed by the court.

SIGNED AND SEALED, this 18th day of October, 2017

HAZARD CONSTRUCTION COMPANY (SEAL)

Nationwide Mutual Insurance Company (SEAL)

(Principal)
By: JASON A. MORDHORST, PRESIDENT
(Signature)

(Surety)
By: KYLE KING
(Signature) **ATTORNEY-IN-FACT**

(SEAL AND NOTARIAL ACKNOWLEDGEMENT OF SURETY)

CALIFORNIA ALL-PURPOSE ACKNOWLEDGMENT

A notary public or other officer completing this certificate verifies only the identity of the individual who signed the document, to which this certificate is attached, and not the truthfulness, accuracy or validity of that document.

State of California

County of San Diego

On October 18, 2017 before me, Apryle M. Briede, Notary Public
Date NAME, TITLE OF OFFICER - E.G. AJANE DOE, NOTARY PUBLIC
personally appeared Jason A. Mordhorst
NAME(S) OF SIGNER(S)

who proved to me on the basis of satisfactory evidence to be the person(s) whose name(s) is/are subscribed to the within instrument and acknowledged to me that he/she/they executed the same in his/her/their authorized capacity(ies) and that by his/her/their signature(s) on the instrument the person(s), or the entity upon behalf of which the person(s) acted, executed the instrument.

I certify under PENALTY OF PERJURY under the laws of the State of California that the foregoing paragraph is true and correct.

WITNESS my hand and official seal.

NOTARY PUBLIC SIGNATURE

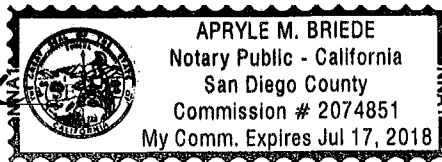

Power of Attorney

KNOW ALL MEN BY THESE PRESENTS THAT:

Nationwide Mutual Insurance Company, an Ohio corporation hereinafter referred to as the "Company" and does hereby make, constitute and appoint:

Minna Huovila, Tara Bacon, Kyle King, Dale Gene Harshaw

each in their individual capacity, its true and lawful attorney-in-fact, with full power and authority to sign, seal, and execute on its behalf any and all bonds and undertakings, and other obligatory instruments of similar nature, in penalties not exceeding the sum of

UNLIMITED

and to bind the Company thereby, as fully and to the same extent as if such instruments were signed by the duly authorized officers of the Company; and all acts of said Attorney pursuant to the authority given are hereby ratified and confirmed.

This power of attorney is made and executed pursuant to and by authority of the following resolution duly adopted by the board of directors of the Company:

"RESOLVED, that the president, or any vice president be, and each hereby is, authorized and empowered to appoint attorneys-in-fact of the Company, and to authorize them to execute and deliver on behalf of the Company any and all bonds, forms, applications, memorandums, undertakings, recognizances, transfers, contracts of indemnity, policies, contracts guaranteeing the fidelity of persons holding positions of public or private trust, and other writings obligatory in nature that the business of the Company may require; and to modify or revoke, with or without cause, any such appointment or authority; provided, however, that the authority granted hereby shall in no way limit the authority of other duly authorized agents to sign and countersign any of said documents on behalf of the Company."

"RESOLVED FURTHER, that such attorneys-in-fact shall have full power and authority to execute and deliver any and all such documents and to bind the Company subject to the terms and limitations of the power of attorney issued to them, and to affix the seal of the Company thereto; provided, however, that said seal shall not be necessary for the validity of any such documents."

This power of attorney is signed and sealed under and by the following bylaws duly adopted by the board of directors of the Company.

Execution of Instruments. Any vice president, any assistant secretary or any assistant treasurer shall have the power and authority to sign or attest all approved documents, instruments, contracts, or other papers in connection with the operation of the business of the company in addition to the chairman of the board, the chief executive officer, president, treasurer or secretary; provided, however, the signature of any of them may be printed, engraved, or stamped on any approved document, contract, instrument, or other papers of the Company.

IN WITNESS WHEREOF, the Company has caused this instrument to be sealed and duly attested by the signature of its officer the 1st day of May, 2017.

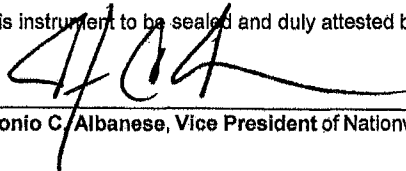

Antonio C. Albanese, Vice President of Nationwide Mutual Insurance Company

ACKNOWLEDGMENT

STATE OF NEW YORK, COUNTY OF NEW YORK: ss
On this 1st day of May, 2017, before me came the above-named officer for the Company aforesaid, to me personally known to be the officer described in and who executed the preceding instrument, and he acknowledged the execution of the same, and being by me duly sworn, deposes and says, that he is the officer of the Company aforesaid, that the seal affixed hereto is the corporate seal of said Company, and the said corporate seal and his signature were duly affixed and subscribed to said instrument by the authority and direction of said Company.

BARRY T. BASSIS
Notary Public, State of New York
No. 02BA4656400
Qualified in New York County
Commission Expires April 30, 2019



Notary Public
My Commission Expires
April 30, 2019



CERTIFICATE

I, Laura B. Guy, Assistant Secretary of the Company, do hereby certify that the foregoing is a full, true and correct copy of the original power of attorney issued by the Company; that the resolution included therein is a true and correct transcript from the minutes of the meetings of the boards of directors and the same has not been revoked or amended in any manner; that said Antonio C. Albanese was on the date of the execution of the foregoing power of attorney the duly elected officer of the Company, and the corporate seal and his signature as officer were duly affixed and subscribed to the said instrument by the authority of said board of directors; and the foregoing power of attorney is still in full force and effect.

IN WITNESS WHEREOF, I have hereunto subscribed my name as Assistant Secretary, and affixed the corporate seal of said Company this

18 day of October, 2017

kk

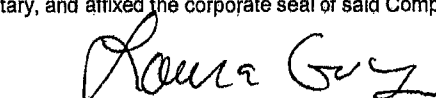

Assistant Secretary

CALIFORNIA ALL-PURPOSE ACKNOWLEDGMENT

A notary public or other officer completing this certificate verifies only the identity of the individual who signed the document, to which this certificate is attached, and not the truthfulness, accuracy or validity of that document.

State of California

County of San Diego

On October 18, 2017 before me, Apryle M. Briede, Notary Public
Date NAME, TITLE OF OFFICER - E.G. AJANE DOE, NOTARY PUBLIC

personally appeared Kyle King
NAME(S) OF SIGNER(S)

who proved to me on the basis of satisfactory evidence to be the person(s) whose name(s) is/are subscribed to the within instrument and acknowledged to me that he/she/they executed the same in his/her/their authorized capacity(ies) and that by his/her/their signature(s) on the instrument the person(s), or the entity upon behalf of which the person(s) acted, executed the instrument.

I certify under PENALTY OF PERJURY under the laws of the State of California that the foregoing paragraph is true and correct.

WITNESS my hand and official seal.

Apryle M. Briede
NOTARY PUBLIC SIGNATURE



CONTRACTOR'S CERTIFICATION OF PENDING ACTIONS

As part of its bid or proposal (Non-Price Proposal in the case of Design-Build contracts), the Bidder shall provide to the City a list of all instances within the past 10 years where a complaint was filed or pending against the Bidder in a legal or administrative proceeding alleging that Bidder discriminated against its employees, subcontractors, vendors or suppliers, and a description of the status or resolution of that complaint, including any remedial action taken.

CHECK ONE BOX ONLY.

- The undersigned certifies that within the past 10 years the Bidder has NOT been the subject of a complaint or pending action in a legal administrative proceeding alleging that Bidder discriminated against its employees, subcontractors, vendors or suppliers.
- The undersigned certifies that within the past 10 years the Bidder has been the subject of a complaint or pending action in a legal administrative proceeding alleging that Bidder discriminated against its employees, subcontractors, vendors or suppliers. A description of the status or resolution of that complaint, including any remedial action taken and the applicable dates is as follows:

DATE OF CLAIM	LOCATION	DESCRIPTION OF CLAIM	LITIGATION (Y/N)	STATUS	RESOLUTION/REMEDIAL ACTION TAKEN
Please see Attached					

Contractor Name: **HAZARD CONSTRUCTION COMPANY**

Certified By **JASON A. MORDHORST, PRESIDENT** Title _____

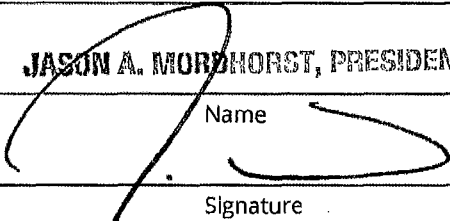
 Name _____
 Signature _____

Date 10/18/17

USE ADDITIONAL FORMS AS NECESSARY

HAZARD CONSTRUCTION COMPANY

CONTRACTORS CERTIFICATION OF PENDING ACTIONS

In March 2013, a lawsuit was filed against Hazard Construction Company by a former employee, Kenneth McDonald, in the Superior Court of California, County of San Diego. McDonald was laid off by Hazard as part of a company-wide labor force reduction in December 2011. The lawsuit stated various allegations of discrimination, harassment, and retaliation against McDonald by Hazard and/or its employees. Hazard's management believed the lawsuit was without merit and vigorously defended against the allegations. This matter was mediated and settled in January 2014 without any admission of wrongdoing or fault by Hazard.

In May 2016, a lawsuit was filed against Hazard Construction Company by a former employee, Trinidad Davalos, in the Superior Court of California, County of San Diego. Davalos was terminated earlier in 2016. The lawsuit stated a claim for wrongful termination due to disability discrimination against Davalos. Hazard's management believes the lawsuit is without merit and has vigorously defended against the allegation. This matter was settled in January 2017 without any admission of wrongdoing or fault by Hazard.

City of San Diego

CITY CONTACT: Brittany Friedenreich, Contract Specialist, Email: BFriedenreic@sandiego.gov
Phone No. (619) 533-3104, Fax No. (619) 533-3633

ADDENDUM B



FOR

TORREY PINES ROAD IMPROVEMENTS PHASE 2 AND TORREY PINES ROAD SLOPE RESTORATION

BID NO.: K-18-1550-DBB-3
SAP NO. (WBS/IO/CC): S-15023, S-00877, B-18014
CLIENT DEPARTMENT: 2116
COUNCIL DISTRICT: 1
PROJECT TYPE: IK, IF

BID DUE DATE:

**2:00 PM
OCTOBER 26, 2107
CITY OF SAN DIEGO
PUBLIC WORKS CONTRACTS
1010 SECOND AVENUE, 14th FLOOR, MS 614C
SAN DIEGO, CA 92101**

A. CHANGES TO CONTRACT DOCUMENTS

The following changes to the Contract Documents are hereby made effective as though originally issued with the bid package. Bidders are reminded that all previous requirements to this solicitation remain in full force and effect.

B. BIDDER'S QUESTIONS

- Q1. Main Bid Torrey Pines Road does not have a Mobilization Item, please add.
- A1. Mobilization for the Torrey Pines Road Phase 2 portion shall be included in the various bid items for Torrey Pines Road Phase 2.
- Q2. What is the basis of low bid determination, the total bid (Main Bid Torrey Pines Rd plus Main Bid Torrey Pines Wall)?
- A2. The low bid will be determined by combined total bid price for both the Torrey Pines Road Phase 2 and the Torrey Pines Road Slope Restoration projects.
- Q3. The boring logs in the project specific specification do not provide existing Asphalt Concrete and Base thickness's to be removed, please provide the existing thickness of Asphalt Concrete and Base on Torrey Pines Road.
- A3. The Geotechnical Investigation report was prepared for Torrey Pines Road Slope Restoration project. A pavement core result for the Torrey Pines Road Phase 2 project is shown on sheet 39770-04-D (D-3). In addition, a pavement core was taken at approx.150' east of Little Street, the results were 6 ½" AC in 4 layers over 7 ½" PCC and at approx.175' east of Viking Street, the results were 8" AC in 4 layers over 7" PCC. The contractor should expect to encounter concrete during any trenching work in the street.
- Q4. The Torrey Pines Road Phase 2 plan set does not provide design contours, please provide design contours to permit all contractors to calculate earthwork and grading quantities for all median, roadway, and sidewalk improvements.
- A4. The existing contours and finish grade contours are adequate to permit all contractors to calculate earthwork and grading quantities for all median, roadway, and sidewalk improvements therefore, no finish grade contours will be provided.

- Q5. Please provide Electronic PDF copies of plan sets – Torrey Pines Road Improvements Phase 2 & Torrey Pines Slope Restoration, both copies originally issued are blurred and not legible, which will in turn produce inaccurate proposals that will increase the overall cost of the project.
- A5. For Torrey Pines Road Phase 2, the drawings provides are adequate for bidding purposes. For the Torrey Pines Road Slope Restoration project, Sheets C-1 (32132-4-D) and C-2 (32132-5-D) are reissued herein (See plan sheets provided in this Addendum) showing the underlying existing contours more prominently.
- Q6. Retaining Wall Sheet C-7, the profile provided for this retaining wall has the incorrect vertical scale. Please provide a new plan sheet with the accurate horizontal and vertical scales.
- A6. Torrey Pines Road Phase 2, Plan Sheet C-7 (39770-13-D) has been correctly rescaled as is reissued herewith (See plan sheet provided in this Addendum).
- Q7. Spec Section 302-5.9.1 – Payment for Asphalt Concrete (For Existing Median Removal), what is the schedule J asphalt depth to be placed in this section of the median, please clarify.
- A7. The full depth of schedule J asphalt to be placed is equal to the depth from the existing pavement surface to the top of PCC below the existing median.
- Q8. Reference Bid Item 37, Relocate Irrigation System. Is this only required for the Main Bid Torrey Pines Road or is it also required for the Wall portion as well? Please provide details for the work required under this Bid Item. Add Bid Item(s) if also required under the wall work.
- A8. Bid Item 37 applies to Main Bid Torrey Pines Road only. The work required under this Bid Item consists of cutting and capping the existing irrigation lines just behind the location of the new sidewalk.
- Q9. The Plans do not indicate or shown any landscape and/or irrigation work to be completed; however, Note 1 and 2 under the Scope of Work (Plan Sheet G-1, Torrey Pines Road Slope Restoration) mentions seeding. Please provide details of any required landscaping, irrigation, hydroseeding, etc. and a method of payment for this work.

A9: Per the scope of work stated on G-1, the seed mix shall be incorporated with the BFM to all areas that are disturbed on the slope. To that please add... This shall also be applied to the parkway between the existing curb face and toe of slope.

No specific bid item was identified for this work. The cost is to be covered under the various bid items.

Q10. In reference to Addendum A, Torrey Pines Slope Restoration Plan Set Provided, it looks like the major existing contours are not shown in this plan set on sheets 4 & 5. Please provide a revised plan set that is in electronic PDF format rather than the photo copy that was issued in Addendum A that shows the Major existing contours.

A10. The existing contours have been made more prominent in sheets C-1 (32132-4-D) and C-2 (32132-5-D) which are reissued herein (See plan sheets provided in this Addendum).

Q11. Regarding Bid Item #50, Sculpted Rock Finish and Stained, we are unable to locate any details within the plans for the type of sculpting required. Does the City have an approved mock up or architectural details that the Contractor should follow? Please provide details, photos, or location of mock up (if exists).

A11. Rock Finish shall be Boulderscape (Finish: Eroded Shale, Color: Medium Earth Blend), or approved equal. The community approved rendering is attached hereto. The contractor shall provide a mock-up per Special Provision Section 305-3.4.1 item 3.

C. ADDENDUM

1. To Addendum A, page 2, Section D, Plans, Item 1, Drawing numbers 32132-4-D (C-1, page 10), 32132-5-D (C-2, page 11), **DELETE** in their entirety and **REPLACE** with pages 7 through 8 of this Addendum.

D. SUPPLEMENTARY SPECIAL PROVISIONS

1. To Attachment E, Supplementary Special Provisions, Appendices, Appendix N, Geotechnical Report, **ADD** "Boulderscape Wall Face Simulation", page 6 of this Addendum.

E. PLANS

1. To Plans, Drawing number 39770-13-D (C-7), **DELETE** in its entirety and **REPLACE** with page 9 of this Addendum.

James Nagelvoort, Director
Public Works Department

Dated: *October 16, 2017*
San Diego, California

JN/HMc/egz

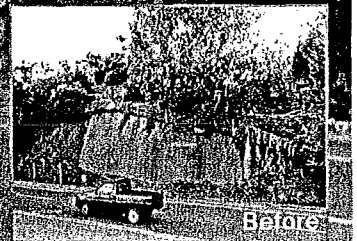
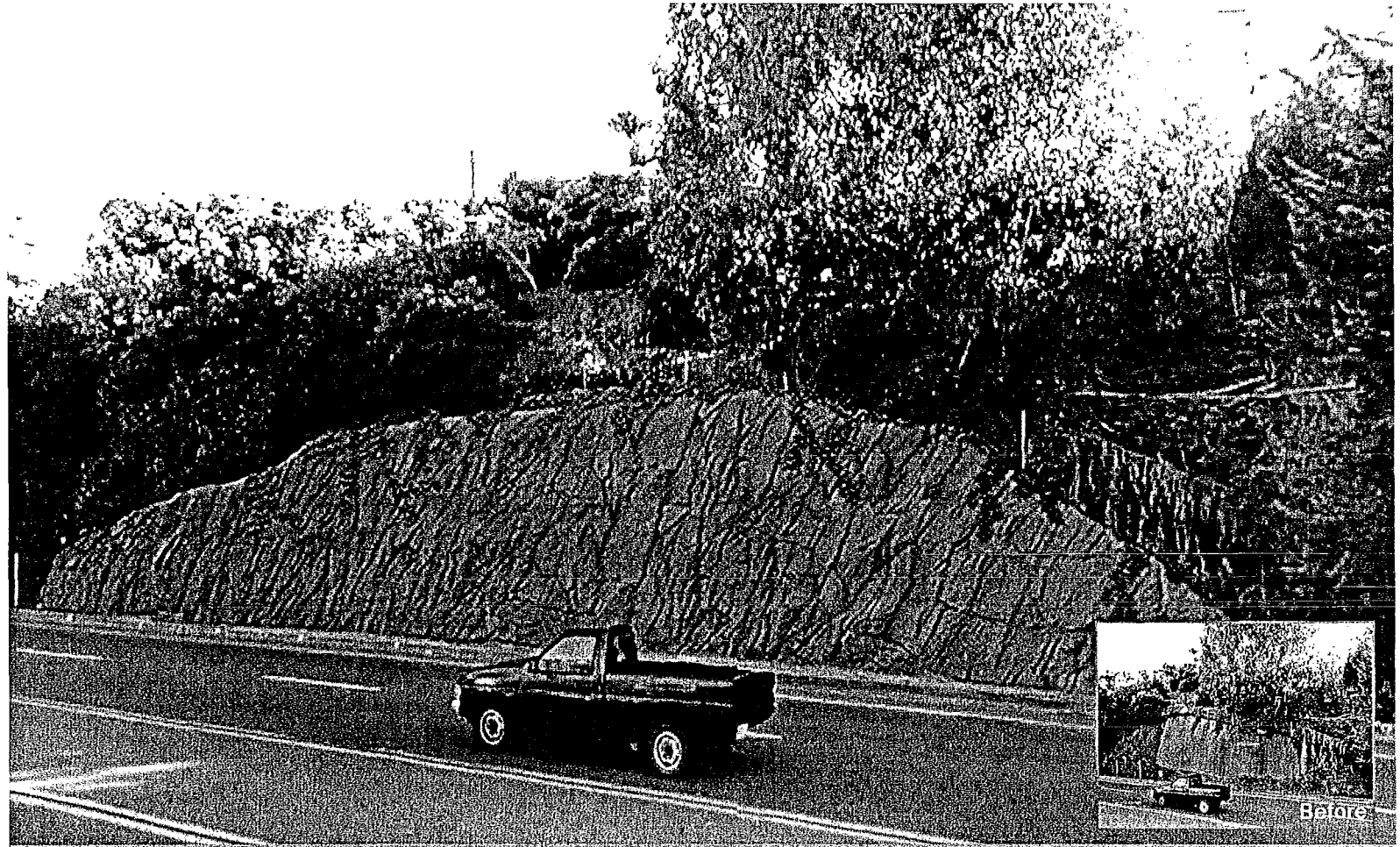

October 13, 2017 Torrey Pines Road Improvements Phase 2 and Torrey Pines Slope Restoration
www.boulderscape.com

ADDENDUM B
"Retaining Nature. Sustaining Beauty."

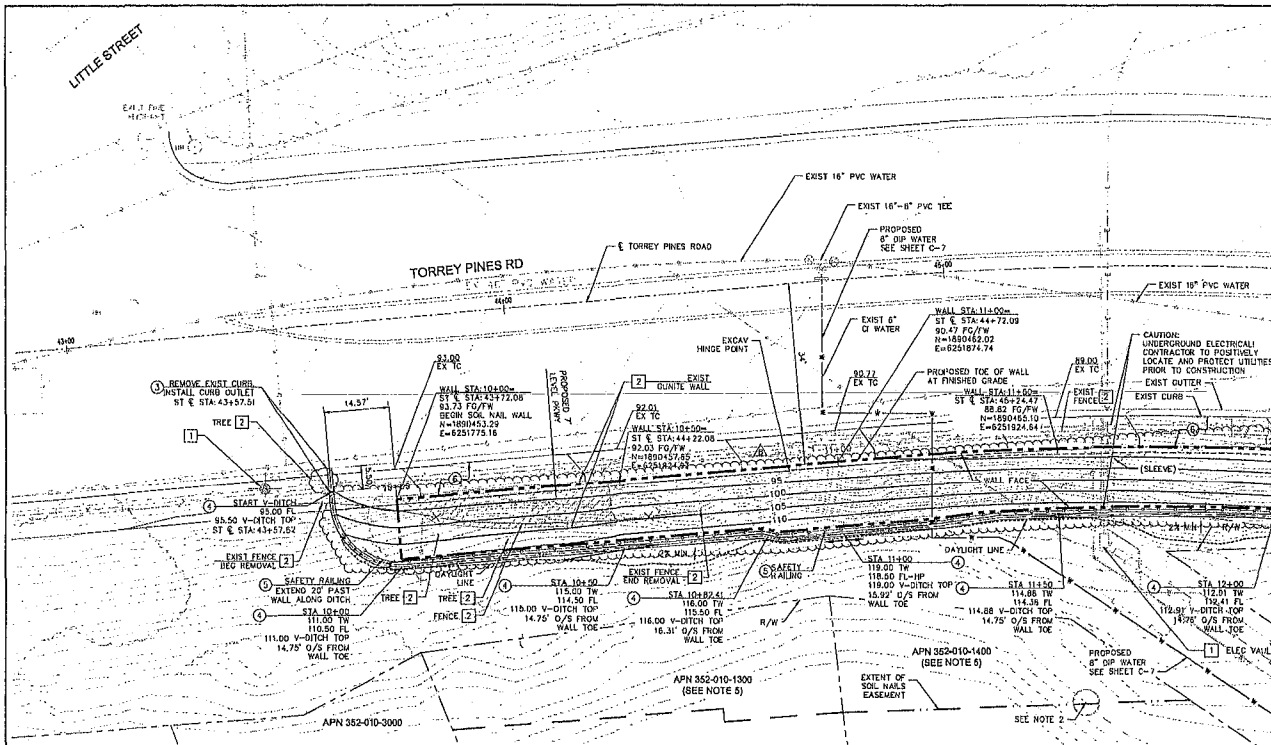

- CONSTRUCTION AND DEMOLITION NOTES:**
- 1 PROTECT IN PLACE
 - 2 TO BE REMOVED
 - 3 TYPE-A CURB OUTLET PER CITY OF SAN DIEGO STANDARDS C-25
 - 4 CONCRETE V-DITCH PER DETAIL PROVIDED. POSITIVE SLOPE TO END OF WALL
 - 5 SAFETY CABLE RAILING PER CALTRANS STD PLAN B11-47
 - 6 FINISH GRADE PARKWAY

MATCHLINE STA 12+00 - SEE SHEET C-2

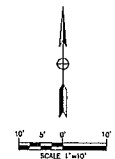

- NOTES:**
1. CONTOUR INTERVAL=1'.
 2. EXISTING TORREY PINE TREE, ON APN #352-010-1400, TO BE PROTECTED DURING CONSTRUCTION. IF TREE ROOTS ARE ENCOUNTERED, CONTRACTOR TO NOTIFY RESIDENT ENGINEER AND TAKE PRECAUTIONS TO MINIMIZE IMPACT UPON TREE ROOTS.
 3. CONTRACTOR SHALL POT-HOLE AND POSITIVELY IDENTIFY & PROTECT ALL UTILITIES IN THE WORK AREA AND NOTIFY THE ENGINEER OF ANY CONFLICTS OR DISCREPANCIES PRIOR TO CONSTRUCTION.
 4. CONTRACTOR SHALL REMOVE ALL INTERFERING TREES AND VEGETATION IN THE WORK AREA AS NECESSARY.
 5. FOR PROPERTY LINE AND EASEMENT DESCRIPTIONS FOR APN 352-010-13 AND 352-010-14, REFER TO CITY OF SAN DIEGO DRAWINGS 20346-B AND 20349-B

DECLARATION OF RESPONSIBLE CHARGE

I HEREBY DECLARE THAT I AM THE ENGINEER OF WORK FOR THIS PROJECT THAT I HAVE EXERCISED RESPONSIBLE CHARGE OVER THE DESIGN OF THE PROJECT AS DEFINED IN SECTION 9703 OF THE BUSINESS AND PROFESSIONS CODE AND THAT THE DESIGN IS CONSISTENT WITH CURRENT STANDARDS. I UNDERSTAND THAT THE CHECK OF PROJECT DRAWINGS AND SPECIFICATIONS BY THE CITY OF SAN DIEGO IS CONFINED TO A REVIEW ONLY AND DOES NOT RELIEVE ME, AS ENGINEER OF WORK, OF MY RESPONSIBILITIES FOR PROJECT DESIGN.

[Signature]
 (ENGINEER'S NAME) 9/8/17
 DATE

ADDENDUM B - INCREASE VISIBILITY OF EXISTING CONTOURS

C-1

IMPROVEMENT PLAN FOR:
 TORREY PINES ROAD SLOPE RESTORATION
 BETWEEN LITTLE STREET
 AND HESSLAND DRIVE
 SAN DIEGO, CALIFORNIA

CITY OF SAN DIEGO, CALIFORNIA
 ENGINEERING DEPARTMENT
 SHEET 4 OF 14 SHEETS

PROJECT NO. 1200
 SHEET NO. 00877

DESIGNED BY	DATE	SCALE
CHECKED BY	DATE	SCALE
APPROVED BY	DATE	SCALE
DATE	SCALE	SCALE

CONTRACTOR: [Blank]
 DATE FORW. TO: [Blank]
 DATE FORW. BY: [Blank]

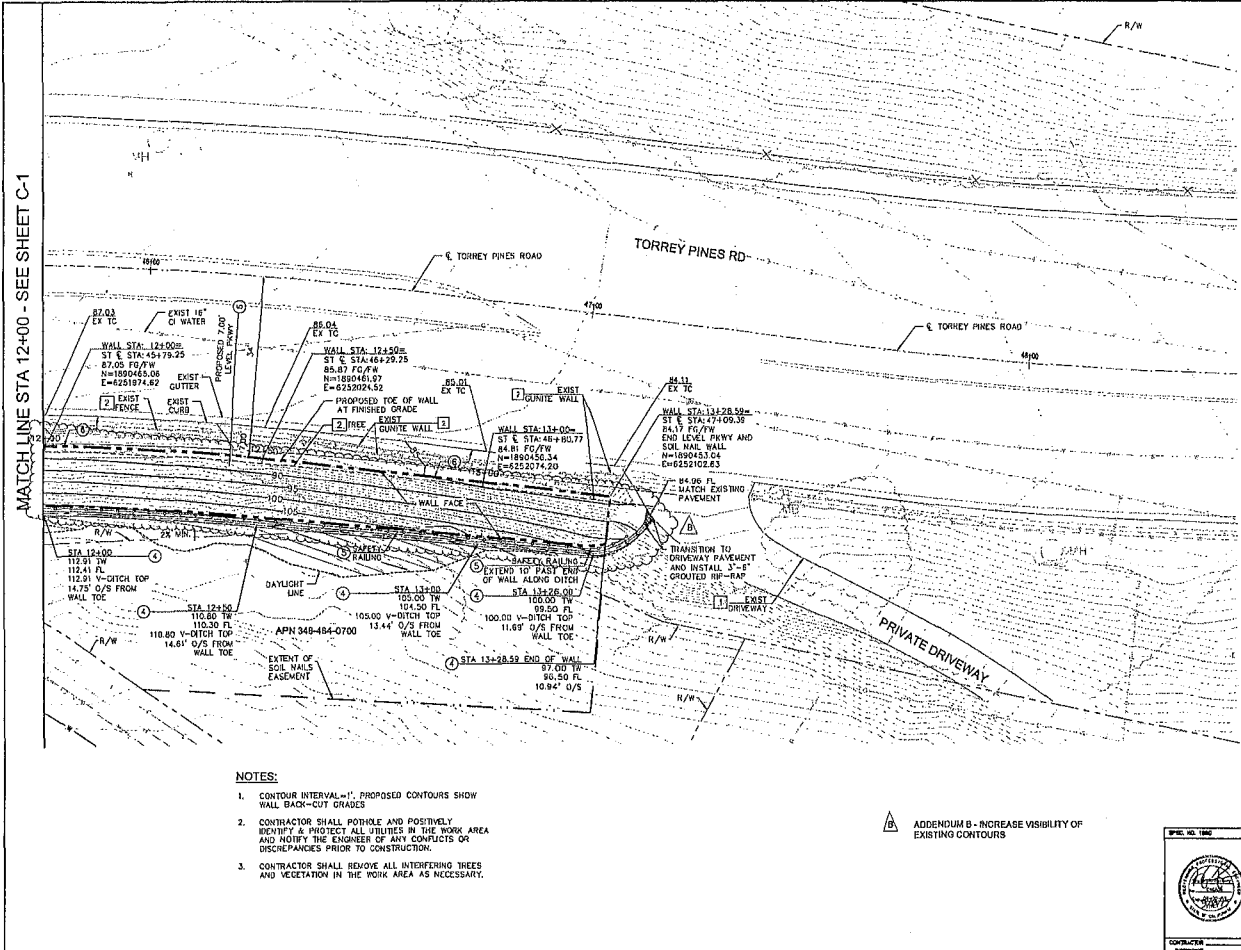

- CONSTRUCTION AND DEMOLITION NOTES:**
- 1] PROTECT IN PLACE
 - 2] TO BE REMOVED
 - 3] NOT USED
 - 4] CONCRETE V-DITCH PER DETAIL 31
 - 5] SAFETY CABLE RAILING PER CALTRANS STD PLAN B11-47
 - 6] FINISH GRADE PARKWAY

MATCH LINE STA 12+00 - SEE SHEET C-1

- NOTES:**
1. CONTOUR INTERVAL=1'. PROPOSED CONTOURS SHOW WALL BACK-CUT GRADES
 2. CONTRACTOR SHALL POTHOLE AND POSITIVELY IDENTIFY & PROTECT ALL UTILITIES IN THE WORK AREA AND NOTIFY THE ENGINEER OF ANY CONFLICTS OR DISCREPANCIES PRIOR TO CONSTRUCTION.
 3. CONTRACTOR SHALL REMOVE ALL INTERFERING TREES AND VEGETATION IN THE WORK AREA AS NECESSARY.

ADDENDUM B - INCREASE VISIBILITY OF EXISTING CONTOURS

C-2

IMPROVEMENT PLAN FOR TORREY PINES ROAD SLOPE RESTORATION BETWEEN LITTLE STREET AND ROSSLAND DRIVE SAN DIEGO, CALIFORNIA

CITY OF SAN DIEGO, CALIFORNIA
DIVISION OF PUBLIC WORKS
SHEET 5 OF 14 SHEETS

S-00877

DATE PREPARED	DATE	DRAWN BY	CHECKED BY	SCALE
APPROVED BY	DATE	DATE	DATE	DATE
APPROVED BY	DATE	DATE	DATE	DATE

DATE SHOWN: 3/21/17
DATE SHOWN: 3/21/17

City of San Diego

CITY CONTACT: Brittany Friedenreich, Contract Specialist, Email: BFriedenreic@sandiego.gov
Phone No. (619) 533-3104, Fax No. (619) 533-3633

ADDENDUM A



FOR

TORREY PINES ROAD IMPROVEMENTS PHASE 2 AND TORREY PINES ROAD SLOPE RESTORATION

BID NO.: K-18-1550-DBB-3
SAP NO. (WBS/IO/CC): S-15023, S-00877, B-18014
CLIENT DEPARTMENT: 2116
COUNCIL DISTRICT: 1
PROJECT TYPE: IK, IF

BID DUE DATE:

2:00 PM

OCTOBER 26, 2017

CITY OF SAN DIEGO

PUBLIC WORKS CONTRACTS

1010 SECOND AVENUE, 14th FLOOR, MS 614C

SAN DIEGO, CA 92101

A. CHANGES TO CONTRACT DOCUMENTS

The following changes to the Contract Documents are hereby made effective as though originally issued with the bid package. Bidders are reminded that all previous requirements to this solicitation remain in full force and effect.

B. ATTACHMENTS

1. To Attachment A, Scope of Work, page 21, Section 1, Scope of Work, subsection 1.2.1.1., **DELETE** in its entirety and **SUBSTITUTE** with the following:

1.2.1.1. The Notice Inviting Bids and Plans numbered **32132-01-D** through **32132-14-D**, and Traffic Control Plans numbered **32132-T1-D** through **32132-T3-D**, inclusive.

C. ADDITIONAL CHANGES

1. The following are additional changes to the Line Items in the PlanetBids Tab, pages 3 through 6 of this Addendum.

For clarity where applicable, **ADDITIONS**, if any, have been **Underlined** and **DELETIONS**, if any, have been **Stricken-out**.

D. PLANS

1. To Contract Documents, **ADD** Drawing Numbered **32132-01-D** through **32132-14-D**, and Traffic Control Plans Numbered **32132-T1-D** through **32132-T3-D**, pages 7 to 23 of this Addendum.

James Nagelvoort, Director
Public Works Department

Dated: *October 2, 2017*
San Diego, California

JN / HM / br

Section	ItemCode	Type	ItemDesc	UnitOfMeasure	Quantity	Reference	UnitPrice
Main Bid Torrey Pines Rd	<u>524126</u>		Bonds (Payment and Performance)	LS	1	2-4.1	
Main Bid Torrey Pines Rd	<u>238990</u>		Video Recording of Existing Conditions	LS	1	7-9.1.1	
Main Bid Torrey Pines Rd	<u>237990</u>		WPCP Implementation	LS	1	7-8.6.4.2	
Main Bid Torrey Pines Rd	<u>541330</u>		WPCP Development	LS	1	7-8.6.4.2	
Main Bid Torrey Pines Rd			Field Orders - Type II	AL	1	9-3.5	45000
Main Bid Torrey Pines Rd	<u>238910</u>		Clearing and Grubbing	LS	1	300-1.4	
Main Bid Torrey Pines Rd	<u>237310</u>		Adjust Existing Sewer Manhole Frame and Cover to Grade (Behind the Curb)	EA	1	301-1.7	
Main Bid Torrey Pines Rd	<u>237310</u>		Adjust Existing Storm Drain Cleanout Frame and Cover to Grade (Behind the Curb)	EA	1	301-1.7	
Main Bid Torrey Pines Rd	<u>237310</u>		Adjust Existing Water Meter to Grade	EA	4	301-1.7	
Main Bid Torrey Pines Rd	<u>237310</u>		Adjust Existing Water Gate Valve Frame and Cover to Grade (Behind the Curb)	EA	1	301-1.7	
Main Bid Torrey Pines Rd	<u>237310</u>		Adjust Existing Electrical Box to Grade	EA	2	301-1.7	
Main Bid Torrey Pines Rd	<u>237310</u>		Adjust Existing Communication Cabinet to Grade	EA	1	301-1.7	
Main Bid Torrey Pines Rd	<u>237310</u>		Cold Mill AC Pavement (2 inch)	SF	170000	302-1.12	
Main Bid Torrey Pines Rd	<u>237310</u>		Asphalt Concrete Overlay (2 inch) including Loop Detector Replacements	TON	2000	302-5.9.2	
Main Bid Torrey Pines Rd	<u>237310</u>		Asphalt Concrete (For Existing Median Removal)	LS	1	302-5.9.1	
Main Bid Torrey Pines Rd	<u>238110</u>		Gravity Retaining Wall (30 inch, Type A)	LF	45	303-1.11	
Main Bid Torrey Pines Rd	<u>238110</u>		Masonry Retaining Wall (Type II)	SF	390	303-4.1.5	
Main Bid Torrey Pines Rd	<u>238110</u>		Masonry Retaining Wall (Type III)	SF	140	303-4.1.5	

Section	ItemCode	Type	ItemDesc	UnitOfMeasure	Quantity	Reference	UnitPrice
Main Bid Torrey Pines Rd	<u>238110</u>		Concrete Monolithic Curb (6 inch)	LF	75	303-5.9	
Main Bid Torrey Pines Rd	<u>238110</u>		Concrete Monolithic Curb (12 inch)	LF	115	303-5.9	
Main Bid Torrey Pines Rd	<u>237310</u>		Sidewalk	SF	2600	303-5.9	
Main Bid Torrey Pines Rd	<u>237310</u>		Curb and Gutter (6 inch Curb, Type G)	LF	130	303-5.9	
Main Bid Torrey Pines Rd	<u>237310</u>		Cross Gutter	SF	435	303-5.9	
Main Bid Torrey Pines Rd	<u>237310</u>		Concrete Driveway (Contiguous)	SF	890	303-5.9	
Main Bid Torrey Pines Rd	<u>237310</u>		Curb Ramp Modified (Type D) with Detectable Warning Tiles	EA	2	303-5.10.2	
Main Bid Torrey Pines Rd	<u>237310</u>		Curb Ramp Modified (Type C1) with Detectable Warning Tiles	EA	2	303-5.10.2	
Main Bid Torrey Pines Rd	<u>237310</u>		Colored Stamped Asphalt Concrete	SF	11340	302-5.11.8	
Main Bid Torrey Pines Rd	<u>237110</u>		Sidewalk Underdrain Pipe (3 inch)	LF	12	306-15.1	
Main Bid Torrey Pines Rd	<u>237110</u>		Relocate Fire Hydrant	EA	1	306-15.6	
Main Bid Torrey Pines Rd	<u>237310</u>		Traffic Striping, Curb and Pavement Markings	LS	1	314-4.3.7	
Main Bid Torrey Pines Rd	<u>237310</u>		Thermoplastic Traffic Striping	LS	1	314-4.4.6	
Main Bid Torrey Pines Rd	<u>237310</u>		Traffic Control	LS	1	601-6	
Main Bid Torrey Pines Rd	<u>238210</u>		Remove and Reinstall Traffic Signs	EA	5	701-2	
Main Bid Torrey Pines Rd	<u>237310</u>		Pedestrian Barricade	EA	8	701-2	
Main Bid Torrey Pines Rd	<u>238210</u>		Hawk Traffic Signal and Street Lighting System	EA	2	701-2	
Main Bid Torrey Pines Rd	<u>238210</u>		SDG&E Fee (EOC Type I)	AL	1	701-2	1500
Main Bid Torrey Pines Rd	<u>561730</u>		Relocate Irrigation System	LS	1	801-8	
Main Bid Torrey Pines Wall	<u>237990</u>		Mobilization	LS	1	9-3.4.1	
Main Bid Torrey Pines Wall	<u>238910</u>		Clearing and Grubbing	LS	1	300-1.4	
Main Bid Torrey Pines Wall	<u>237310</u>		Traffic Control	LS	1	601-6	
Main Bid Torrey Pines Wall	<u>237310</u>		Structural Excavation	CY	560	300-3.6	

Section	ItemCode	Type	ItemDesc	UnitOfMeasure	Quantity	Reference	UnitPrice
Main Bid Torrey Pines Wall	<u>237990</u>		Soil Nailing - 33' Deep	EA	7	305-3.5	
Main Bid Torrey Pines Wall	<u>237990</u>		Soil Nailing - 36' Deep	EA	28	305-3.5	
Main Bid Torrey Pines Wall	<u>237990</u>		Soil Nailing - 40' Deep	EA	230	305-3.5	
Main Bid Torrey Pines Wall	<u>237990</u>		Soil Nail Testing-Verification Tests	EA	2	305-3.5	
Main Bid Torrey Pines Wall	<u>237990</u>		Soil Nail Testing-Proof Tests	EA	14	305-3.5	
Main Bid Torrey Pines Wall	<u>237990</u>		Soil Nail Testing-Performance Tests	EA	2	305-3.5	
Main Bid Torrey Pines Wall	<u>238110</u>		4" minimum Shotcrete-Primary Structural Fascia & Rebar/WWM	CY	98	305-3.5	
Main Bid Torrey Pines Wall	<u>238110</u>		10" minimum Thick Shotcrete-Rebar & Misc Metal Works for Arch Fascia	CY	246	305-3.5	
Main Bid Torrey Pines Wall	<u>237990</u>		Sculpted Rock Finish and Stained	SF	8000	305-3.5	
Main Bid Torrey Pines Wall	<u>237990</u>		Structural Backfill	CY	35	305-3.5	
Main Bid Torrey Pines Wall	<u>237110</u>		12" Wide by 6" Deep Concrete Brow Ditch	LF	340	303-1.11	
Main Bid Torrey Pines Wall	<u>237110</u>		Concrete Stone Channel Outlet - Private Dr	EA	1	303-1.11	
Main Bid Torrey Pines Wall	<u>237990</u>		Cable and Rail Post - 42" High	LF	350	305-3.5	
Main Bid Torrey Pines Wall	<u>237110</u>		Water Main Ductile Iron (8 Inch, Class 350)	LF	340	306-15.1	
Main Bid Torrey Pines Wall	<u>237110</u>		Ductile Iron Water Pipeline Corrosion Protection	LS	1	306-15.13	
Main Bid Torrey Pines Wall	<u>237110</u>		Cutoff Wall (WP-07)	EA	3	303-1.11	
Main Bid Torrey Pines Wall	<u>237990</u>		Construct Wall Drain System	LS	1	305-3.5	
Main Bid Torrey Pines Wall	<u>238990</u>		Video Recording of Existing Conditions	LS	1	7-9.1.1	
Main Bid Torrey Pines Wall	<u>237990</u>		Anti-Graffiti Coating	SF	8000	305-3.5	
Main Bid Torrey Pines Wall	<u>237310</u>		Finish Grading at Bottom of Wall (EOC Type I)	AL	1	300-2.9	4000

Section	ItemCode	Type	ItemDesc	UnitOfMeasure	Quantity	Reference	UnitPrice
Main Bid Torrey Pines Wall	<u>237310</u>		Asphalt Pavement Repair	SF	4000	302-3.2	
Main Bid Torrey Pines Wall	<u>237110</u>		Removal or Abandonment of Existing Water Facilities	LS	1	306-3.3.3	
Main Bid Torrey Pines Wall	<u>237310</u>		Removal of Traffic Striping and Curb Markings	LS	1	314-2.3	
Main Bid Torrey Pines Wall	<u>238910</u>		Site Storage and Handling of Construction and Demolition Waste	LS	1	7-21.9	
Main Bid Torrey Pines Wall	<u>541330</u>		WPCP Development	LS	1	7-8.6.4.2	
Main Bid Torrey Pines Wall	<u>237990</u>		WPCP Implementation	LS	1	7-8.6.4.2	
Main Bid Torrey Pines Wall			Field Orders (EOC Type II)	AL	1	9-3.5	150000
Main Bid Torrey Pines Wall	<u>524126</u>		Bonds (Payment and Performance)	LS	1	2-4.1	
Main Bid Torrey Pines Wall	<u>237110</u>		Pavement Restoration for Final Connection	SF	200	901-2.5	

GENERAL NOTES

1. THE CONTRACTOR SHALL BE RESPONSIBLE FOR SURVEY MONUMENTS AND/OR VERTICAL CONTROL BENCH MARKS WHICH ARE DESTROYED OR DESTROYED BY CONSTRUCTION. A LAND SURVEYOR MUST FIELD LOCATE, REFERENCE, AND/OR PRESERVE ALL HISTORICAL OR CONTROLLING MONUMENTS PRIOR TO ANY EARTHWORKS. IF DESTROYED A LAND SURVEYOR SHALL REPLACE SUCH MONUMENTS WITH APPROPRIATE MONUMENTS. A CORNER RECORD OR RECORD OF SURVEY, AS APPROPRIATE, SHALL BE FILED AS REQUIRED BY THE PROFESSIONAL LAND SURVEYORS ACT. IF ANY VERTICAL CONTROL IS TO BE DISTURBED OR DESTROYED THE CITY OF SAN DIEGO FIELD SURVEY SECTION MUST BE NOTIFIED IN WRITING, AT LEAST 3 DAYS PRIOR TO THE CONSTRUCTION. THE CONTRACTOR WILL BE RESPONSIBLE FOR THE COST OF REPLACING ANY VERTICAL CONTROL BENCH MARKS DESTROYED BY THE CONSTRUCTION.
2. IMPORTANT NOTICE, SECTION 4216 OF THE GOVERNMENT CODE REQUIRES A DIG ALERT IDENTIFICATION NUMBER BE ISSUED BEFORE A PERMIT TO EXCAVATE WILL BE VALID. FOR YOUR DIG ALERT ID NUMBER CALL UNDERGROUND SERVICE ALERT, TOLL FREE 1-800-422-4133, TWO DAYS BEFORE YOU DIG.
3. CONTRACTOR SHALL IMPLEMENT AN EROSION AND SEDIMENT CONTROL PROGRAM DURING THE PROJECT GRADING AND/OR CONSTRUCTION ACTIVITIES. THE PROGRAM SHALL MEET ALL APPLICABLE REQUIREMENTS OF THE STATE WATER RESOURCE CONTROL BOARD AND THE CITY OF SAN DIEGO MUNICIPAL CODE AND STORM WATER STANDARD MANUAL.
4. "PUBLIC IMPROVEMENT SUBJECT TO DESUETUDE OR DAMAGE." IF REPAIR OR REPLACEMENT OF SUCH PUBLIC IMPROVEMENTS IS REQUIRED, THE OWNER SHALL OBTAIN THE REQUIRED PERMITS FOR WORK IN THE PUBLIC RIGHT OF WAY SATISFACTORY TO THE PERMIT ISSUING AUTHORITY.
5. ALL EXISTING AND/OR PROPOSED PUBLIC UTILITY SYSTEM AND SERVICE FACILITIES SHALL BE INSTALLED UNDERGROUND IN ACCORDANCE WITH SECTION 1440240 OF THE MUNICIPAL CODE.
6. PRIOR TO ANY DISTURBANCE TO THE SITE, EXCLUDING UTILITY MARK-OUTS AND SURVEYING, THE CONTRACTOR SHALL MAKE ARRANGEMENTS FOR PRE-CONSTRUCTION MEETING WITH THE CITY OF SAN DIEGO FIELD ENGINEERING DIVISION (858) 627-3200.
7. DEVIATION FROM THESE SIGNED PLANS WILL NOT BE ALLOWED UNLESS A CONSTRUCTION CHANGE IS APPROVED BY THE CITY ENGINEER OR THE CHANGE IS REQUIRED BY THE CITY INSPECTOR.
8. AS-BUILT DRAWINGS MUST BE SUBMITTED TO THE RESIDENT ENGINEER PRIOR TO ACCEPTANCE OF THIS PROJECT BY THE CITY OF SAN DIEGO.

SPECIAL NOTES

THE FOLLOWING NOTES ARE PROVIDED TO GIVE DIRECTIONS TO THE CONTRACTOR BY THE ENGINEER OF WORK. THE CITY ENGINEER'S SIGNATURE ON THESE PLANS DOES NOT CONSTITUTE APPROVAL OF ANY OF THESE NOTES AND THE CITY WILL NOT BE RESPONSIBLE FOR THEIR ENFORCEMENT. THE CONTRACTOR SHALL ENFORCE ALL SAFETY MEASURES.

1. NEITHER THE OWNER NOR THE ENGINEER OF WORK WILL ENFORCE SAFETY MEASURES OR REGULATIONS. THE CONTRACTOR SHALL DESIGN, CONSTRUCT AND MAINTAIN ALL SAFETY DEVICES, INCLUDING SHORING, AND SHALL BE SOLELY RESPONSIBLE FOR CONFORMING TO ALL LOCAL, STATE AND FEDERAL SAFETY AND HEALTH STANDARDS, LAWS AND REGULATIONS.
2. CONTRACTOR AGREES THAT THEY SHALL ASSUME SOLE AND COMPLETE RESPONSIBILITY FOR JOBSITE CONDITIONS DURING THE COURSE OF CONSTRUCTION OF THIS PROJECT, INCLUDING SAFETY OF ALL PERSONS AND PROPERTY, AND THIS REQUIREMENT SHALL APPLY CONTINUOUSLY AND NOT BE LIMITED TO NORMAL WORKING HOURS, AND THAT THE CONTRACTOR SHALL DEFEND, INDEMNIFY AND HOLD THE OWNER AND ENGINEER HARMLESS FROM ANY AND ALL LIABILITY, REAL OR ALLEGED IN CONNECTION WITH THE PERFORMANCE OF WORK ON THIS PROJECT EXCEPTING LIABILITY ARISING FROM THE SOLE NEGLIGENCE OF THE OWNER OR THE ENGINEER.
3. THE CONTRACTOR SHALL BE RESPONSIBLE TO INSURE THAT ALL SLOPES, STREETS, UTILITIES AND STORM DRAINS ARE BUILT IN ACCORDANCE WITH THESE PLANS. IF THERE IS QUESTION REGARDING THESE PLANS OR FIELD STAKES, THE CONTRACTOR SHALL REQUEST AN INTERPRETATION BEFORE DOING ANY WORK BY CALLING THE RESIDENT ENGINEER. THE CONTRACTOR SHALL ALSO TAKE THE NECESSARY STEPS TO PROTECT THE PROJECT AND ADJACENT PROPERTY FROM ANY EROSION AND SILTATION THAT RESULT FROM HIS OPERATIONS BY APPROPRIATE MEANS (SAND BAGS, HAY BALES, TEMPORARY DESILTING BASINS, DIKES SHORING, ETC) UNTIL SUCH TIME THAT THE PROJECT IS COMPLETED AND ACCEPTED FOR MAINTENANCE BY WHATEVER OWNER OR ASSOCIATION IS TO ULTIMATELY BE RESPONSIBLE FOR MAINTENANCE.
4. CONTRACTOR SHALL MAKE EXPLORATION EXCAVATIONS AND LOCATE EXISTING UNDERGROUND FACILITIES SUFFICIENTLY AHEAD OF CONSTRUCTION TO PERMIT REVISIONS TO PLANS IF REVISIONS ARE NECESSARY BECAUSE OF ACTUAL LOCATION OF EXISTING FACILITIES.

SPECIAL NOTES CONT'D

5. LOCATION AND ELEVATION OF EXISTING IMPROVEMENTS TO BE MET BY WORK TO BE DONE SHALL BE CONFIRMED BY FIELD MEASUREMENTS PRIOR TO CONSTRUCTION OF NEW WORK.
6. BEFORE EXCAVATING FOR THIS CONTRACT, THE CONTRACTOR SHALL VERIFY LOCATION OF UNDERGROUND UTILITIES, THE EXISTENCE AND LOCATION OF ANY UNDERGROUND UTILITY PIPES OR STRUCTURES SHOWN ON THESE PLANS WERE OBTAINED BY A SEARCH OF THE AVAILABLE RECORDS.
7. CONTRACTOR SHALL NOTIFY THE SAN DIEGO GAS AND ELECTRIC COMPANY PRIOR TO STARTING WORK NEAR COMPANY FACILITIES AND SHALL COORDINATE HIS WORK WITH COMPANY REPRESENTATIVES.
NOTICE: ALL ELECTRICAL AND GAS SERVICES WITHIN THIS PROJECT AREA ARE "UNDERGROUND INSTALLATIONS" FOR LOCATIONS OF ELECTRICAL CABLES AND GAS PIPING AND APPURTENANCES, CONTACT THE SAN DIEGO GAS & ELECTRIC COMPANY TELEPHONE: 655-554-6662.
8. CONTRACTOR SHALL NOTIFY THE AT&T TELEPHONE COMPANY PRIOR TO STARTING WORK NEAR COMPANY FACILITIES AND SHALL COORDINATE HIS WORK WITH COMPANY REPRESENTATIVES.
NOTICE: ALL TELEPHONE SERVICES WITHIN THIS PROJECT AREA ARE "UNDERGROUND INSTALLATIONS" FOR LOCATION OF CABLES AND APPURTENANCES. CONTACT AT&T AT: 658-288-2683.
9. CONTRACTOR IS REQUIRED TO TAKE PRECAUTIONARY MEASURES TO PROTECT THE UTILITY LINES SHOWN HEREON AND ANY OTHER EXISTING LINES NOT OF RECORD OR NOT SHOWN ON THESE PLANS.
10. THE CONTRACTOR SHALL TAKE THE NECESSARY PRECAUTIONS REQUIRED TO PROTECT ADJACENT PROPERTIES DURING THE GRADING OPERATIONS.
11. CUT AND FILL SHALL BE TRIMMED TO THE FINISHED GRADE TO PRODUCE A SMOOTH SURFACE AND UNIFORM CROSS SECTION. THE SLOPE OF THE EXCAVATIONS OR EMBANKMENTS SHALL BE SHAPED AND TRIMMED AS SHOWN ON THE PLANS AND LEFT IN A NEAT AND ORDERLY CONDITION. ALL STONES, ROOTS OR OTHER WASTE MATTER EXPOSED ON EXCAVATION OR EMBANKMENT SLOPES SHALL BE REMOVED AND DISPOSED OF OFF SITE IN A LEGAL MANNER BY THE CONTRACTOR.
12. THE EXISTENCE AND LOCATIONS OF UNDERGROUND UTILITIES OR STRUCTURES SHOWN ON THESE PLANS WERE OBTAINED FROM A SEARCH OF AVAILABLE RECORDS. THE CONTRACTOR IS REQUIRED TO TAKE PRECAUTIONARY MEASURES TO PROTECT THE UTILITY LINES SHOWN ON THESE PLANS. ALL DAMAGES THERE TO CAUSED BY THE CONTRACTOR SHALL BE REPAIRED TO THE APPROPRIATE SPECIFICATIONS AND AT THE EXPENSE OF THE CONTRACTOR.
13. THE CONTRACTOR SHALL KEEP THE EQUIPMENT AND CONSTRUCTION ACTIVITIES OUTSIDE OF THE OPEN SPACE AREA AND SHALL NOT DISTURB THE NATIVE VEGETATION, UNLESS WRITTEN PERMISSION IS GRANTED BY THE CITY.
14. RESTORATION OF ROADWAY, THE CONTRACTOR SHALL REPAIR OR REPLACE ALL EXISTING IMPROVEMENTS WITHIN THE RIGHT-OF-WAY WHICH ARE NOT DESIGNATED FOR PERMANENT REMOVAL FOR TRAFFIC SIGNS, STRIPING, PAVEMENT MARKINGS, LEGENDS, CURB MARKINGS, LOOP DETECTORS, TRAFFIC SIGNAL EQUIPMENT, ETC WHICH ARE DAMAGED OR REMOVED AS A RESULT OF OPERATIONS, REPAIRS AND REPLACEMENTS SHALL AT LEAST EQUAL TO EXISTING IMPROVEMENTS.
15. CONTRACTOR TO REPLACE STRIPING AFTER OVERLAY OF STREETS TO MATCH EXISTING.

SPECIAL INSPECTION

1. FIELD INSPECTION AND TESTING WILL BE PERFORMED BY THE GEOTECHNICAL ENGINEER OF RECORD.
2. PERFORM ALL WORK UNDER THE CONTINUOUS OBSERVATION OF THE GEOTECHNICAL ENGINEER OF RECORD.
3. TESTS AND ANALYSIS OF FILL MATERIAL WILL BE PERFORMED IN ACCORDANCE WITH CURRENT ASTM STANDARDS AND LOCAL GRADING ORDINANCES.
4. THE GEOTECHNICAL ENGINEER WILL REVIEW AND APPROVE ALL FILL MATERIALS, INCLUDING ON-SITE MATERIALS AND IMPORTED MATERIALS.
5. COMPACTION TESTING WILL BE PERFORMED IN ACCORDANCE WITH ASTM D1556, ASTM D6938 OR OTHER REFERENCED METHODS.
6. IF TESTS INDICATE WORK DOES NOT MEET SPECIFIED REQUIREMENTS, REMOVE WORK, REPLACE AND RETEST AT NO COST TO OWNER.
7. CONTINUOUS OBSERVATION OF SOIL-NAIL ANCHORING INSTALLATION AND WALL PANEL DRAINS BY THE GEOTECHNICAL ENGINEER.

SOIL NAIL AND SHOTCRETE NOTES

1. SOIL NAIL INSTALLATION AND TESTING SHALL COMPLY WITH THE GEOTECHNICAL REPORT(S) DATED MAY 17, 2011 BY: LEIGHTON AND ASSOCIATES, INC. 2804 MURPHY CANYON ROAD, SUITE B205 SAN DIEGO, CA 92123-4425
2. PRIOR TO COMMENCING THE SOIL NAIL CONSTRUCTION OPERATION, BUILDING AND EQUIPMENT IN CLOSE PROXIMITY SHALL BE SURVEYED BY THE CONTRACTOR TO DOCUMENT THE EXISTING CONDITIONS. THE PROPERTY SHALL BE CONTINUOUSLY MONITORED DURING CONSTRUCTION AND UNUSUAL CONDITIONS SHALL BE BROUGHT TO THE ATTENTION OF THE PROJECT ENGINEER FOR EVALUATION AND DEVELOPMENT REMEDIAL SOLUTIONS.
3. THE ENGINEER MAY SUSPEND THE WORK IF THE CONTRACTOR USES NON-APPROVED PERSONNEL. IF WORK IS SUSPENDED, THE CONTRACTOR SHALL BE FULLY LIABLE FOR ALL RESULTING COSTS AND NO ADJUSTMENT IN CONTRACT TIME WILL RESULT FROM THE SUSPENSION.
4. PRIOR TO PLACEMENT OF SHOTCRETE, ALL LOOSE SOIL AND VEGETATION SHALL BE REMOVED TO FIRM MATERIAL, AS APPROVED BY THE GEOTECHNICAL ENGINEER. CLEARING AND GRUBBING AND REMOVALS SHALL PRESERVE THE NATURAL CONTOUR OF THE SLOPE AS MUCH AS POSSIBLE AND RENDER THE SLOPE SMOOTH ENOUGH TO PLACE THE WIRE MESH OR REBARS.
5. THE CONTRACTOR SHALL BE RESPONSIBLE FOR LOCATING ALL THE SOIL NAILS AND TREE WELLS INDICATED ON THE PLANS.
6. SOIL NAIL DRILLING SHALL BE CONDUCTED UNDER THE OBSERVATION OF THE PROJECT GEOTECHNICAL ENGINEER, WILLIAM D. OLSON, GEOTECHNICAL ENGINEER, AND MIKE D. JENSEN, GEOLOGIST AT (619) 292-8030 FOR THE CITY OF SAN DIEGO.
7. A REGISTERED DEPUTY INSPECTOR APPROVED BY THE DEPARTMENT OF BUILDING AND SAFETY IS REQUIRED DURING DRILLING AND SHOTCRETE PLACEMENT.
8. DRILLED HOLES SHALL BE FILLED WITH GROUT IMMEDIATELY AFTER THE STEEL IS PLACED.

G-2

IMPROVEMENT PLAN FOR: TORREY PINES ROAD SLOPE RESTORATION BETWEEN LITTLE STREET AND RUSSELL DRIVE SAN DIEGO, CALIFORNIA		CITY OF SAN DIEGO, CALIFORNIA ENGINEERING DEPARTMENT SHEET 2 OF 14 SHEETS		858 620-8110	858 620-8110
DATE: 07-12-17		PROJECT MANAGER: [Signature]		S 008277	
FOR CITY ENGINEER: [Signature]	DATE: 07-12-17	DESIGNED BY: [Signature]	PROJECT ENGINEER: [Signature]	SHEET NO. 32132-2-D	
BY: [Signature]	DATE: 07-12-17	PROJECT MANAGER: [Signature]	PROJECT ENGINEER: [Signature]	SHEET NO. 32132-2-D	

EROSION AND SEDIMENT CONTROL NOTES

TEMPORARY EROSION/SEDIMENT CONTROL, PRIOR TO COMPLETION OF FINAL IMPROVEMENTS, SHALL BE PERFORMED BY THE CONTRACTOR OR QUALIFIED PERSON AS INDICATED BELOW:

1. ALL REQUIREMENTS OF THE CITY OF SAN DIEGO "LAND DEVELOPMENT MANUAL, STORM WATER STANDARDS" MUST BE INCORPORATED INTO THE DESIGN AND CONSTRUCTION OF THE PROPOSED GRADING IMPROVEMENTS CONSISTENT WITH THE APPROVED STORM WATER POLLUTION PREVENTION PLAN (SWPPP) AND/OR WATER POLLUTION CONTROL PLAN (WPCP) FOR CONSTRUCTION LEVEL BMP'S AND FOR PERMANENT POST CONSTRUCTION TREATMENT CONTROL PERMANENT BMP'S, THE WATER QUALITY TECHNICAL REPORT (WQTR) IF APPLICABLE.
2. FOR STORM DRAIN INLETS, PROVIDE A GRAVEL BAG SILT BASIN IMMEDIATELY UPSTREAM OF INLET AS INDICATED ON DETAILS.
3. FOR INLETS LOCATED AT SLUMPS ADJACENT TO TOP OF SLOPES, THE CONTRACTOR SHALL ENSURE THAT WATER DRAINING TO THE SUMP IS DIRECTED INTO THE INLET AND THAT A MINIMUM OF 1.00' FREEBOARD EXISTS AND IS MAINTAINED ABOVE THE TOP OF THE INLET. IF FREEBOARD IS NOT PROVIDED BY GRADING SHOWN ON THESE PLANS, THE CONTRACTOR SHALL PROVIDE IT VIA TEMPORARY MEASURES, I.E. GRAVEL BAGS OR DIKES.
4. THE CONTRACTOR OR QUALIFIED PERSON SHALL BE RESPONSIBLE FOR CLEANUP OF SILT AND MUD ON ADJACENT STREET(S) AND STORM DRAIN SYSTEM DUE TO CONSTRUCTION ACTIVITY.
5. THE CONTRACTOR OR QUALIFIED PERSON SHALL CHECK AND MAINTAIN ALL LINED AND UNLINED DITCHES AFTER EACH RAINFALL.
6. THE CONTRACTOR SHALL REMOVE SILT AND DEBRIS AFTER EACH MAJOR RAINFALL.
7. EQUIPMENT AND WORKERS FOR EMERGENCY WORK SHALL BE MADE AVAILABLE AT ALL TIMES DURING THE RAINY SEASON. ALL NECESSARY MATERIALS SHALL BE STOCKPILED ON SITE AT CONVENIENT LOCATIONS TO FACILITATE RAPID CONSTRUCTION OF TEMPORARY DEVICES WHEN RAIN IS IMMINENT.
8. THE CONTRACTOR SHALL RESTORE ALL EROSION/SEDIMENT CONTROL DEVICES TO WORKING ORDER TO THE SATISFACTION OF THE CITY ENGINEER OR RESIDENT ENGINEER AFTER EACH RUN-OFF PRODUCING RAINFALL.
9. THE CONTRACTOR SHALL INSTALL ADDITIONAL EROSION/SEDIMENT CONTROL MEASURES AS MAY BE REQUIRED BY THE RESIDENT ENGINEER DUE TO UNCOMPLETED OPERATIONS OR UNFORESEEN CIRCUMSTANCES, WHICH MAY ARISE.
10. THE CONTRACTOR SHALL BE RESPONSIBLE AND SHALL TAKE NECESSARY PRECAUTIONS TO PREVENT PUBLIC TRESPASS ONTO AREAS WHERE IMPOUNDED WATERS CREATE A HAZARDOUS CONDITION.
11. ALL EROSION/SEDIMENT CONTROL MEASURES PROVIDED PER THE APPROVED GRADING PLAN SHALL BE INCORPORATED HEREON. ALL EROSION/SEDIMENT CONTROL FOR INTERIM CONDITIONS SHALL BE DONE TO THE SATISFACTION OF THE RESIDENT ENGINEER.
12. GRADED AREAS AROUND THE PROJECT PERIMETER MUST DRAIN AWAY FROM THE FACE OF THE SLOPE AT THE CONCLUSION OF EACH WORKING DAY.
13. ALL REMOVABLE PROTECTIVE DEVICES SHOWN SHALL BE IN PLACE AT THE END OF EACH WORKING DAY WHEN RAIN IS IMMINENT.
14. THE CONTRACTOR SHALL ONLY GRADE, INCLUDING CLEARING AND GRUBBING FOR THE AREAS FOR WHICH THE CONTRACTOR OR QUALIFIED PERSON CAN PROVIDE EROSION/SEDIMENT CONTROL MEASURES.
15. THE CONTRACTOR SHALL ARRANGE FOR WEEKLY MEETINGS DURING OCTOBER 1ST TO APRIL 30TH FOR PROJECT TEAM (GENERAL CONTRACTOR, QUALIFIED PERSON, EROSION CONTROL SUBCONTRACTOR IF ANY, ENGINEER OF WORK, OWNER/DEVELOPER AND THE RESIDENT ENGINEER) TO EVALUATE THE ADEQUACY OF THE EROSION/SEDIMENT CONTROL MEASURES AND OTHER RELATED CONSTRUCTION ACTIVITIES.

8-INCH DIP CORROSION PROTECTION NOTES

NOTE NO.	ITEM	REFERENCE	
1	DUCTILE IRON PIPE EXTERNAL COATING REQUIREMENT		<p>1. PROVIDE A CORROSION PREVENTATIVE COATING ON ALL BURIED DUCTILE IRON PIPE AND FITTINGS INCLUDING ALL BENDS, TEES, CROSSES, FLEX COUPLINGS, FLANGE BOLTS, AND VALVES. THE COATING (EPOXY, FUSION BONDED EPOXY, WAX TAPE, OR POLYURETHANE) SHALL CONFORM TO THE STANDARD SPECIFICATIONS FOR PUBLIC WORKS CONSTRUCTION (WHITE BOOK) PART 206-1.12. NOTE THAT THIS COATING REQUIREMENT IS NOT SATISFIED BY SUPPLYING DUCTILE IRON PIPE WITH THE STANDARD SHOP APPLIED BLACK PRIMER.</p> <p>THE EXTERNAL SURFACES OF ALL DUCTILE IRON PIPE AND FITTINGS, INCLUDING VALVES AND APPURTENANCES FOR BURIED SERVICE SHALL BE COATED WITH ONE OF THE FOLLOWING:</p> <p>A) 24 MILS MINIMUM DRY FILM THICKNESS (MDFT) LIQUID EPOXY COATING IN ACCORDANCE WITH AWWA C210. COAL TAR EPOXIES SHALL NOT BE USED.</p> <p>B) 24 MILS MDFT FUSION BONDED EPOXY COATING IN ACCORDANCE WITH AWWA C213 AND AWWA C116.</p> <p>C) A COLD APPLIED THREE-PART SYSTEM, 80 MILS PETROLEUM WAX TAPE COATING IN ACCORDANCE WITH AWWA C217.</p> <p>D) 24 MILS MDFT 100% SOLIDS POLYURETHANE COATING IN ACCORDANCE WITH AWWA C222.</p> <p>PRIOR TO COATING, THE DUCTILE IRON PIPE EXTERNAL SURFACES SHALL BE BLAST CLEANED IN ACCORDANCE WITH THE APPLICABLE NATIONAL ASSOCIATION OF PIPE FABRICATORS (NAPF) STANDARD S02-05. SURFACE PREPARATION STANDARD FOR DUCTILE IRON PIPE AND FITTINGS RECEIVING SPECIAL EXTERNAL COATINGS AND/OR SPECIAL INTERNAL LININGS. AFTER COATING APPLICATION, THE ENTIRE COATED SURFACE SHALL BE INSPECTED WITH A HOLIDAY DETECTOR IN ACCORDANCE WITH NATIONAL ASSOCIATION OF CORROSION ENGINEERS (NACE INTERNATIONAL) STANDARD GP188-2006. DISCONTINUITY (HOLIDAY) TESTING OF NEW PROTECTIVE COATINGS ON CONDUCTIVE SUBSTRATES."</p>
2	DUCTILE IRON PIPE EXTERNAL COATING REQUIREMENT		
3	PIPE JOINT JUMPER WIRES	SEE CITY SD STD DWG. SDW 122 AND SDW 125	EXOTHERMICALLY WELD TWO #6 AWG COPPER CP BOND CABLES ACROSS EACH DUCTILE IRON PIPE JOINT, FITTING, BEND, VALVE FLANGE, OR PIPE SPECIAL.
4	CITY OF SD WSD PIPE INSPECTION BEFORE BACKFILL		CONTACT WATER SYSTEM OPERATIONS - CORROSION SECTION, MR BRENDAN SHEEHAN AT 619.527.5439 ONCE ALL CP JUMPER CABLES HAVE BEEN INSTALLED FOR AN INSPECTION PRIOR TO BACKFILLING THE DUCTILE IRON PIPE. THE CITY OF SD WILL PERFORM AN ELECTRICAL RESISTANCE TEST OF EACH COMPLETED SECTION OF NEW DUCTILE IRON PIPE TO ENSURE THAT ALL PIPE JOINTS HAVE BEEN ADEQUATELY BONDED ACROSS.
5	CATHODIC PROTECTION ANODES		PROVIDE AND INSTALL A TOTAL OF 4 EACH 32 POUND MAGNESIUM ANODES AT OR NEAR PIPELINE STATION 2+00 OR AS FIELD DIRECTED BY CITY OF SD ENGINEER TO AVOID UNDERGROUND CONFLICTS. CONTACT WSD CORROSION SECTION BRENDAN SHEEHAN AT 619.527.5439 DURING CONSTRUCTION FOR A FIELD MEET TO DIRECT ACTUAL LOCATION OF MAGNESIUM ANODES. SUBMIT A CATALOG INFORMATION SHEET OF THE MAGNESIUM ANODES TO THE CITY OF SD WSD CORROSION SECTION FOR REVIEW AND APPROVAL PRIOR TO COMMENCING THE ANODE INSTALLATIONS. USE A BACKHOE OR AUGER DRILLING RIG TO BURY EACH MAGNESIUM ANODE A MINIMUM OF 10 FEET DEEP AND AT MINIMUM SPACINGS OF 15 FEET BETWEEN EACH ANODE AND AT A MINIMUM OFFSET FROM THE PIPELINE OF 6 FEET. BEFORE BACKFILLING THE ANODES SATURATE THE SOIL AROUND THEM WITH A MINIMUM OF 25 GALLONS OF POTABLE WATER EACH BACKFILL. THE ANODES WITH NATIVE 2 INCH MINUS ROCK FREE SOIL. COMPACTION OF SOIL AT EACH ANODE IS NOT REQUIRED UNLESS OTHERWISE REQUIRED FOR STREETS OR SIDEWALKS OR OTHER REASONS AT EACH ANODE LOCATION.
6	CATHODIC PROTECTION TEST BOX	SEE CITY SD STD DWG. SDW 121, SDW 125, SDW 128, SDW 152	PROVIDE AND INSTALL A CP TEST BOX AT OR NEAR PIPELINE STATION 2+00 TO DIRECT BURY THE ANODE WIRES TO AND PROVIDE AN ADDITIONAL 5 FEET OF WIRE COILED INSIDE IT. RUN TWO #6 AWG HRWPE DIRECT DURAL WIRES FROM THE CP TEST BOX TO THE WATER PIPELINE AND CONNECT THEM TO THE PIPE WITH EXOTHERMIC WELDS. CONSTRUCT A CONCRETE PAD AROUND THE CP TEST BOX.
7	CATHODIC PROTECTION SYSTEM INSPECTION		CONTACT WATER SYSTEM OPERATIONS - CORROSION SECTION, MR BRENDAN SHEEHAN AT 619.527.5439 ONCE ALL CATHODIC PROTECTION ANODES AND TEST WIRES HAVE BEEN RUN TO THE CP TEST BOX. THE CITY OF SD WILL TEST AND ACTIVATE THE CATHODIC PROTECTION SYSTEM AND COMPLETE THE WIRE CONNECTIONS INSIDE THE CP TEST BOX.

G-3

IMPROVEMENT PLAN FOR:
TORREY PINES ROAD SLOPE RESTORATION
BETWEEN LITTLE STREET
AND HUSKLAND DRIVE
SAN DIEGO, CALIFORNIA

CITY OF SAN DIEGO, CALIFORNIA
ENGINEERING DEPARTMENT
SHEET 3 OF 14 SHEETS

DATE: 07-12-17
DATE CHECKED: []
DATE APPROVED: []

FOR CITY ENGINEER: []
FOR PROJECT MANAGER: []
FOR PROJECT ENGINEER: []
FOR COST COORDINATOR: []
FOR SHEET COORDINATOR: []

32132-3-D

LITTLE STREET

TORREY PINES RD

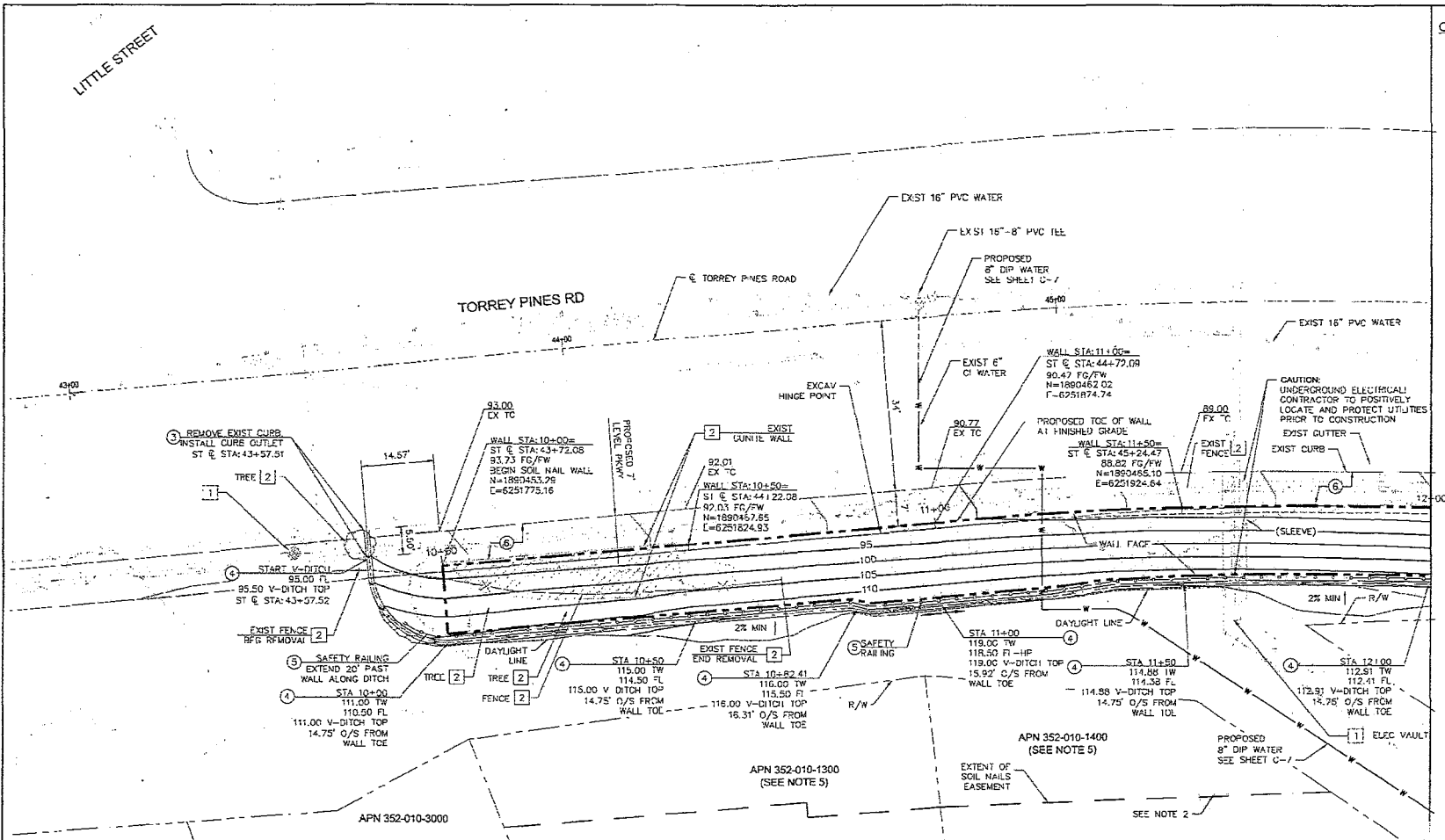

CONSTRUCTION AND DEMOLITION NOTES

- 1 PROTECT IN PLACE
- 2 TO BE REMOVED
- 3 TYPE-A CURB OUTLET PER CITY OF SAN DIEGO STANDARDS D-25
- 4 CONCRETE V-DITCH PER DETAIL PROVIDE POSITIVE SLOPE TO END OF WALL
- 5 SAFETY CABLE RAILING PER CALTRANS STD PLAN B11-47
- 6 FINISH GRADE PARKWAY

MATCH LINE STA 12+00 - SEE SHEET C-2

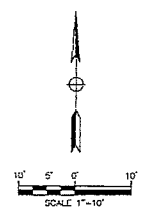

NOTES:

1. CONTOUR INTERVAL=1'
2. EXISTING TORREY PINE TREE, ON APN #352-010-1400, TO BE PROTECTED DURING CONSTRUCTION. IF TREE ROOTS ARE ENCOUNTERED, CONTRACTOR TO NOTIFY RESIDENT ENGINEER AND TAKE PRECAUTIONS TO MINIMIZE IMPACT UPON TREE ROOTS.
3. CONTRACTOR SHALL POTHOLE AND POSITIVELY IDENTIFY & PROTECT ALL UTILITIES IN THE WORK AREA AND NOTIFY THE ENGINEER OF ANY CONFLICTS OR DISCREPANCIES PRIOR TO CONSTRUCTION.
4. CONTRACTOR SHALL REMOVE ALL INTERFERING TREES AND VEGETATION IN THE WORK AREA AS NECESSARY.
5. FOR PROPERTY LINE AND EASEMENT DESCRIPTIONS FOR APN 352-010-13 AND 352-010-14, REFER TO CITY OF SAN DIEGO DRAWINGS 20348-B AND 20349-B

DECLARATION OF RESPONSIBLE CHARGE

* I HEREBY DECLARE THAT I AM THE ENGINEER OF WORK FOR THIS PROJECT THAT I HAVE EXERCISED RESPONSIBLE CHARGE OVER THE DESIGN OF THE PROJECT AS DEFINED IN SECTION 6703 OF THE BUSINESS AND PROFESSIONS CODE AND THAT THE DESIGN IS CONSISTENT WITH CURRENT STANDARDS. I UNDERSTAND THAT THE CHECK OF PROJECT DRAWINGS AND SPECIFICATIONS BY THE CITY OF SAN DIEGO IS CONFINED TO A REVIEW ONLY AND DOES NOT RELIEVE ME, AS ENGINEER OF WORK, OF MY RESPONSIBILITIES FOR PROJECT DESIGN.

 (ENGINEER'S NAME)
 9/18/17
 DATE

C-1

IMPROVEMENT PLAN FOR TORREY PINES ROAD SLOPE RESTORATION BETWEEN LITTLE STREET AND ROSELAND DRIVE SAN DIEGO, CALIFORNIA

CITY OF SAN DIEGO, CALIFORNIA
 ENGINEERING DEPARTMENT
 SHEET 4 OF 14 SHEETS

SAN DIEGO PROJECT NUMBER: S-00877

DESIGNER	DATE	APPROVED	DATE	PLUMED
PROJECT ENGINEER	09-12-17			
DATE				

CONTRACTOR: DATE ESTIMATED: DATE COMPLETED: 32132-4-D

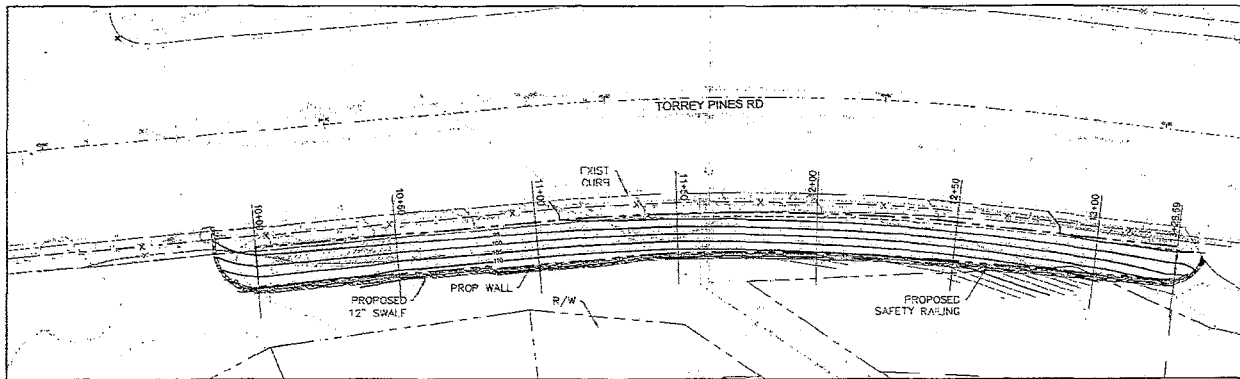
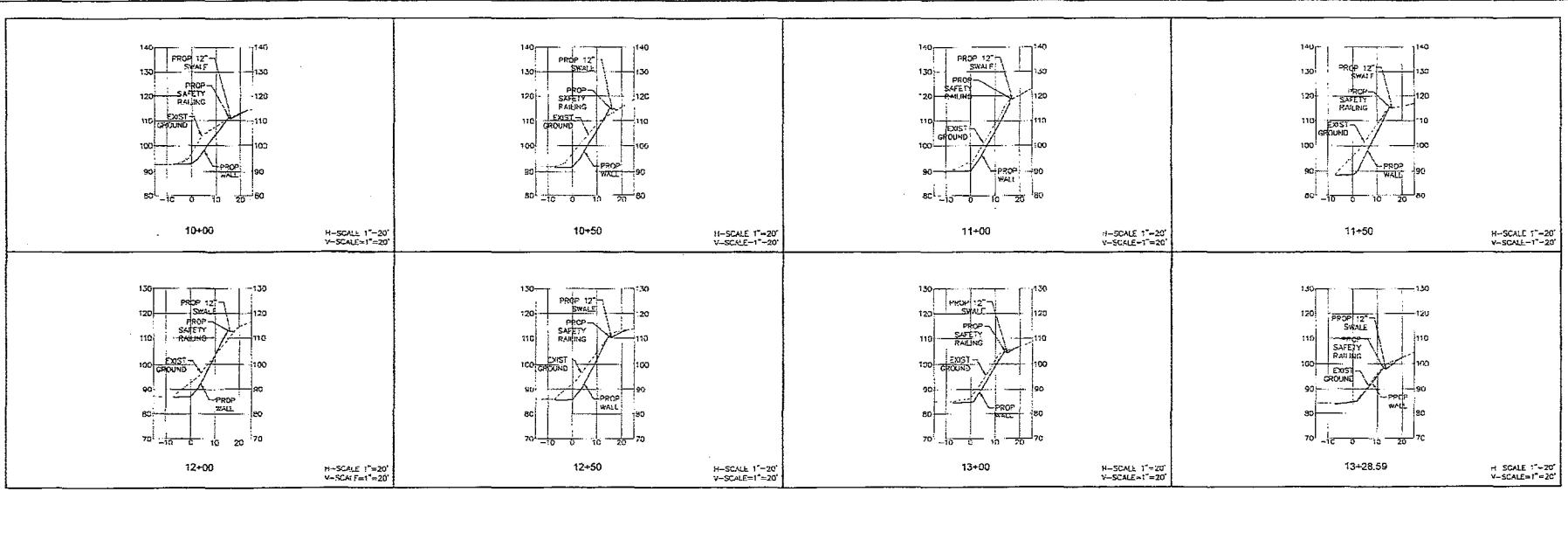

CROSS SECTIONS

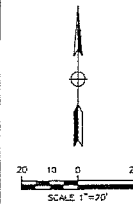

C-5

IMPROVEMENT PLAN FOR:
TORREY PINES ROAD SLOPE RESTORATION
BETWEEN LITTLE STREET
AND ROSSLAND DRIVE
SAN DIEGO, CALIFORNIA

SPEC. NO. 1000		CITY OF SAN DIEGO, CALIFORNIA		DATE: 08-21-17
ENGINEERING DEPARTMENT		SHEET 8 OF 14 SHEETS		PROJECT NO. S-00877
DESIGNED BY: [Signature]	CHECKED BY: [Signature]	DATE: 08-21-17	PROJECT MANAGER:	PROJECT ENGINEER:
APPROVED BY: [Signature]	DATE: 08-21-17	PROJECT OFFICER:	CONTRACTOR:	DATE STARTED:
CONTRACTOR:	DATE COMPLETED:	CONTRACT NO.:	32132-8-D	

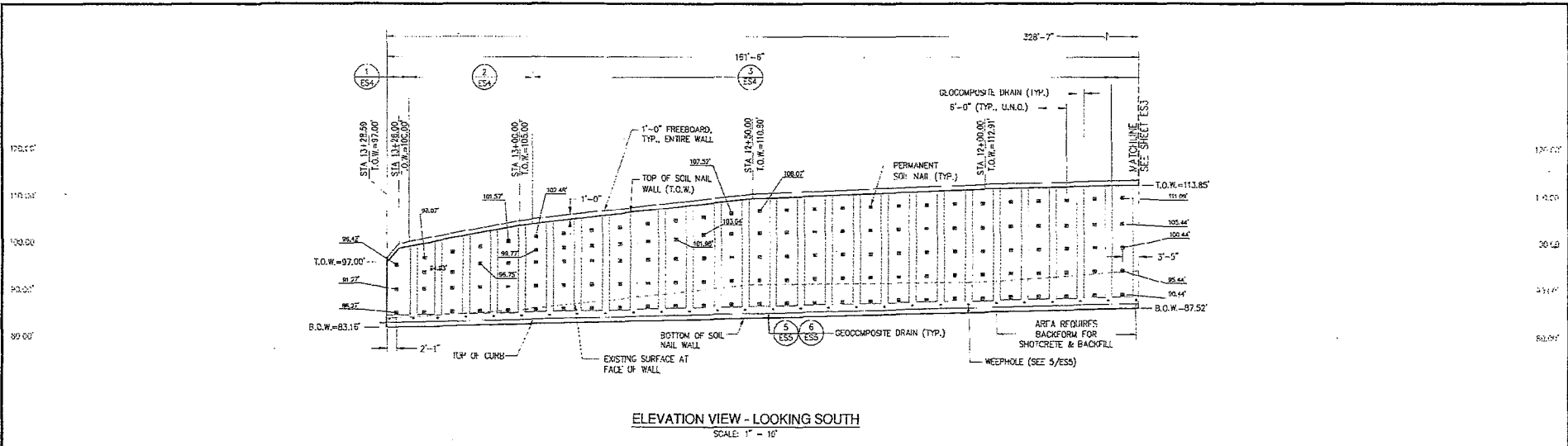

ELEVATION VIEW - LOOKING SOUTH
SCALE: 1" = 10'

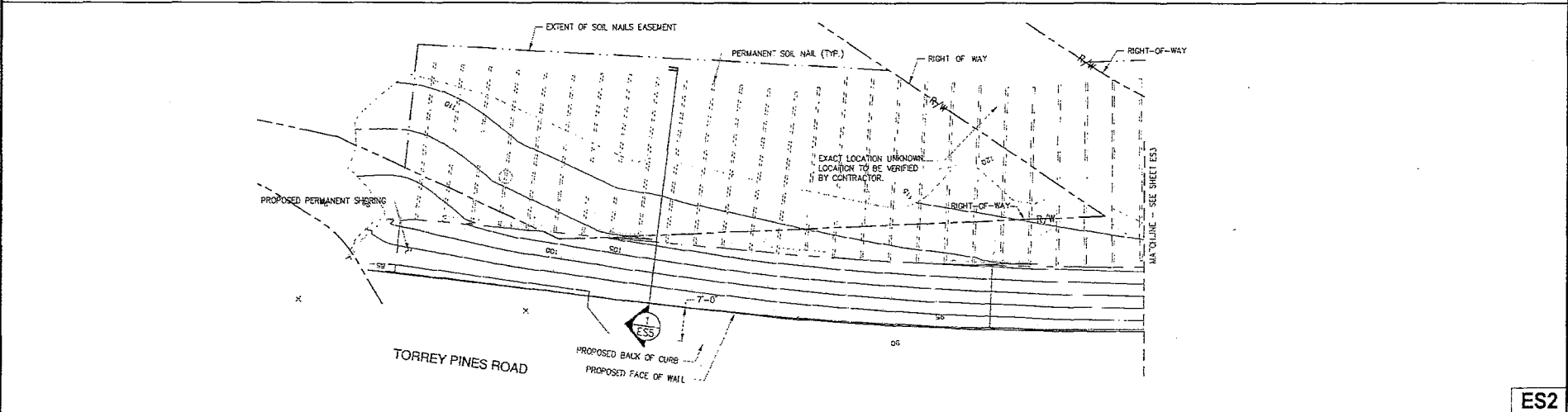

PLAN VIEW - SOUTH
SCALE: 1" = 10'

ES2

TORREY PINES ROAD SLOPE RESTORATION
BETWEEN LITTLE STREET
AND ROSCEND DRIVE
SAN DIEGO, CALIFORNIA

CITY OF SAN DIEGO, CALIFORNIA
ENGINEERING DEPARTMENT
SHEET 10 OF 14 SHEETS

WBS: S-00877

SPEC. NO. 1550	DATE: 01-17	WBS: S-00877	
	TYP. CITY ENGINEER MICHAEL J. ORSATTI 01936 STATE OF CALIFORNIA	JACOB GARCIA PROJECT MANAGER TORREY PINES PROJECT ENGINEER	DATE STARTED: _____ DATE COMPLETED: _____
ORIGINAL BY: _____ APPROVED: _____ DATE: _____ DRAWN: _____	SEE SHEETS 32132-10-D SEE SHEETS 32132-10-D		CONTRACTOR: _____ DATE STARTED: _____ DATE COMPLETED: _____

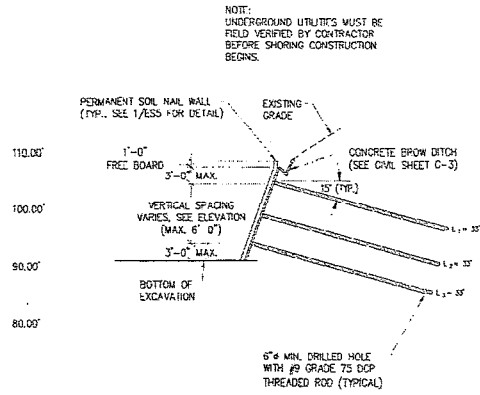

1 SOIL NAIL WALL SECTION
N.T.S.

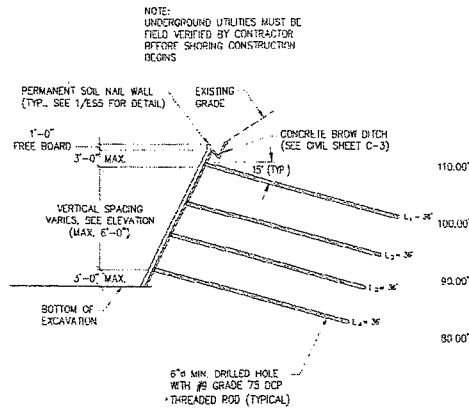

2 SOIL NAIL WALL SECTION
N.T.S.

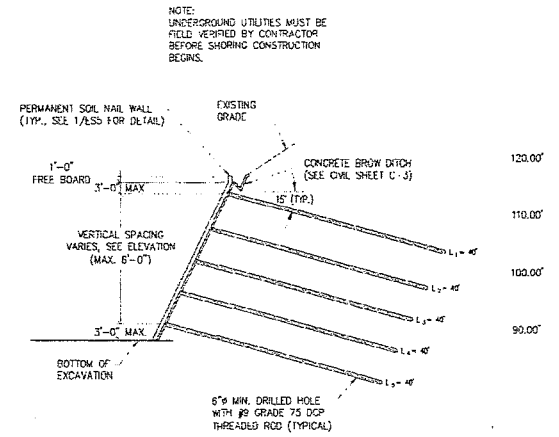

3 SOIL NAIL WALL SECTION
N.T.S.

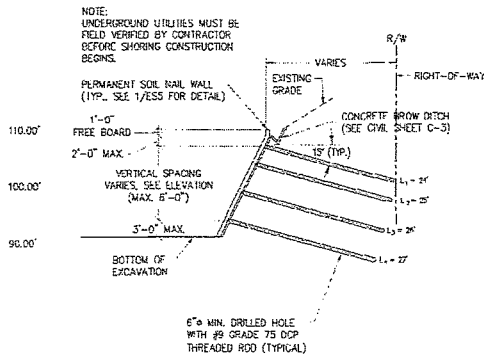

4 SOIL NAIL WALL SECTION
N.T.S.

NOTE:
NAIL DIAMETERS, LENGTHS AND QUANTITIES ARE THE MINIMUM CALCULATED VALUES BASED ON THE PROVIDED GEOTECHNICAL CRITERIA. CONTRACTOR MAY ADJUST TO OBTAIN REQUIRED ANCHOR FRICTION, WITH THE APPROVAL OF THE SOIL NAIL WALL ENGINEER.

ES4

TORREY PINES ROAD SLOPE RESTORATION
BETWEEN LITTLE STREET
AND ROSSELAND DRIVE
SAN DIEGO, CALIFORNIA

CITY OF SAN DIEGO, CALIFORNIA
ENGINEERING DEPARTMENT
SHEET 12 OF 14 SHEETS

SPEC. NO. 1550

DATE: 09-12-17

DESIGNED BY: [Signature]

CHECKED BY: [Signature]

APPROVED BY: [Signature]

DATE FILLED: []

CONTRACTOR SUPERVISOR: []

DATE STARTED: []

DATE COMPLETED: []

32132-12-D

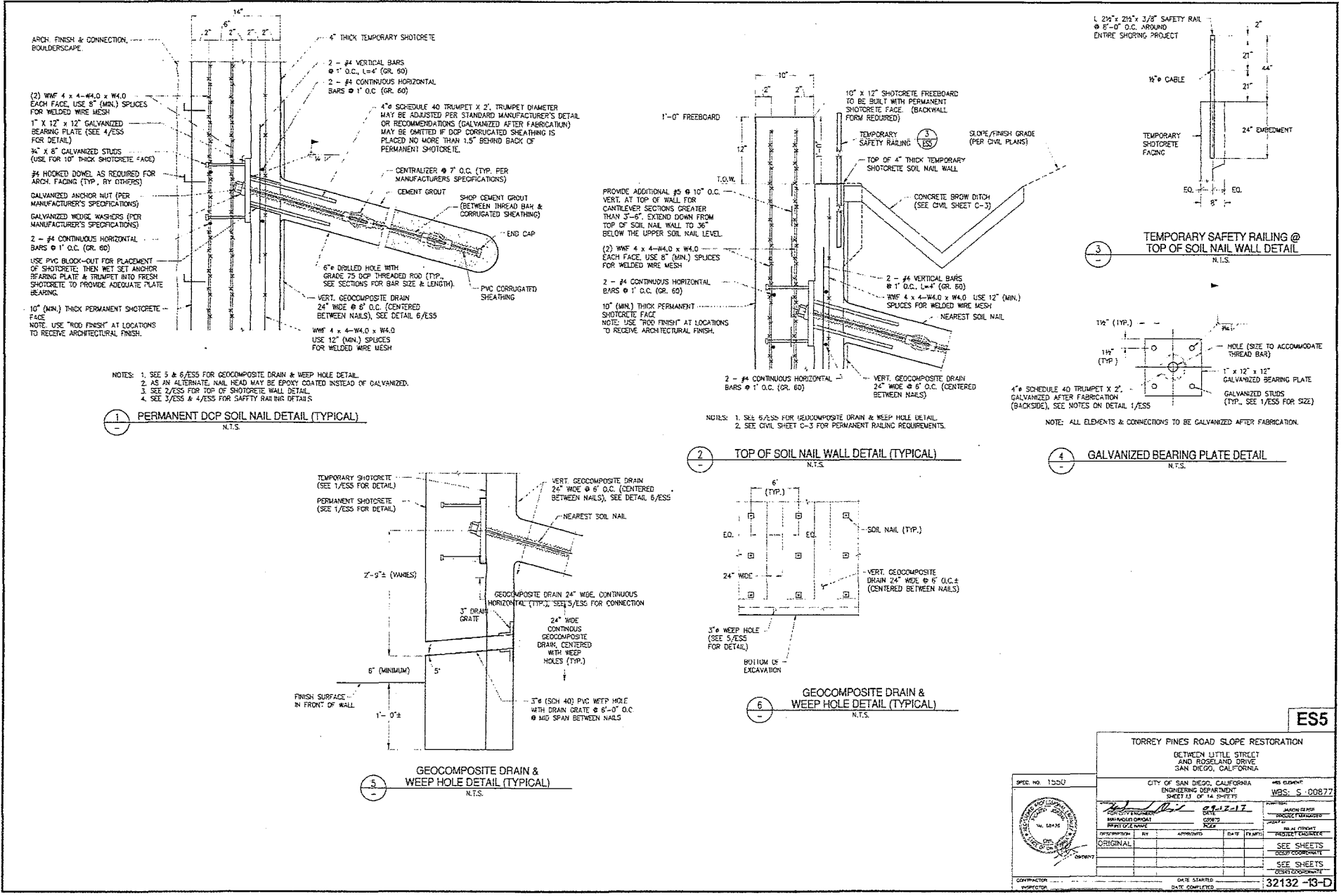

GENERAL NOTES AND DEFINITIONS

1. THE SOIL NAIL WALL ENGINEER IS DEFINED AS THE REGISTERED CIVIL ENGINEER WHOSE STAMP RESIDES ON THESE DRAWINGS.
2. THE GENERAL CONTRACTOR (GC) IS AS DEFINED WITHIN THE CONTRACT DOCUMENTS.
3. CONSTRUCTION SHALL CONFORM TO ALL APPLICABLE SAFETY AND CONSTRUCTION CODES.
4. THE SHORING CONTRACTOR IS DEFINED AS THE ENTITY WHICH INSTALLS THE SUPPORT SYSTEM(S) SHOWN ON, AND DESCRIBED WITHIN THE CONTRACT DOCUMENTS.
5. UNLESS OTHERWISE NOTED, THE SHORING AND SUPPORT SYSTEMS DEPICTED WITHIN THESE DRAWINGS ARE TEMPORARY SYSTEMS WITH A LIMITED STRUCTURAL LIFE. THEY ARE INTENDED TO FACILITATE THE CONSTRUCTION OF PERMANENT STRUCTURES. THEREFORE, THE NEW STRUCTURES MUST BE DESIGNED TO ACCOMMODATE ALL APPLICABLE LOADS ON A PERMANENT BASIS.
6. GENERAL SITE EXCAVATION SHALL BE COORDINATED WITH THE INSTALLATION OF THE SHORING SYSTEM TO ENSURE SAFE WORKING CONDITIONS AND TO PREVENT THE LOSS OF GROUND AND THE CAVING OF BANKS.
7. PILE DRIVING EQUIPMENT, DRILL EQUIPMENT & CRANES SHALL NOT BE LOCATED WITHIN TEN (10) FEET OF THE WALL BULKHEAD UNLESS SPECIFICALLY PROVIDED FOR IN THE DESIGN AND SPECIFICALLY SHOWN IN THESE DRAWINGS.
8. THE GENERAL CONTRACTOR SHALL VERIFY ALL DIMENSIONS AND CONDITIONS AT THE SITE AND REPORT ANY VARIATIONS TO THE SOIL NAIL WALL ENGINEER.
9. THE GENERAL CONTRACTOR SHALL COORDINATE WITH DRAWINGS OF RECORD TO ENSURE PROVISIONS OF ROCKETS, BLOCKOUTS, OFFSETS AND ANY OTHER ITEMS THAT MAY BE IN CONFLICT WITH, OR AFFECTED BY, THE SHORING SYSTEM.
10. ALL STRUCTURAL DETAILS OR SHAPES SHOWN ARE THOSE UTILIZED FOR DESIGN. ALTERNATE DETAILS, CONNECTIONS, SHAPES AND/OR MATERIALS MAY BE USED SUBJECT TO THE APPROVAL OF THE SOIL NAIL WALL ENGINEER.
11. THE GENERAL CONTRACTOR SHALL PERIODICALLY MONITOR THE FACE OF SHOTCRETE AS THE EXCAVATION DESCENDS. THE SURVEY DATA SHALL BE REDUCED AND INTERPRETED, AND TRANSMITTED TO THE SOIL NAIL WALL ENGINEER.
12. IF IN THE OPINION OF THE SOIL NAIL WALL ENGINEER, MONITORING DATA INDICATES EXCESSIVE MOVEMENT, ALL EXCAVATION SHALL CEASE UNTIL THE SOIL NAIL WALL ENGINEER INVESTIGATES THE SITUATION AND MAKES RECOMMENDATIONS FOR REMEDIATION OR CONTINUING. IN ADDITION, THE SURVEY DATA WILL BE USED BY THE SHORING CONTRACTOR TO MAINTAIN ALIGNMENT OF THE SOIL NAIL WALL.

MONITORING (SOIL NAIL WALL)

MONITORING OF THE SURROUNDING GRADE ADJACENT TO THE SHORED EXCAVATION AND EXISTING STRUCTURES SHALL BE PERFORMED AT REGULAR INTERVALS, NOT TO EXCEED FIVE DAYS OR WITH EACH LIFT OF THE EXCAVATION (WHICHEVER IS MORE FREQUENT), TO CONFIRM THAT SETTLEMENTS & LATERAL MOVEMENT AGREE WITH THOSE ESTIMATED. (MAXIMUM ESTIMATED SETTLEMENT & LATERAL MOVEMENT = 1.0 INCH) MONITORING MAY BE PERFORMED WEEKLY IF THE RESULTS OF PERFORMANCE MONITORING INDICATE STABLE CONDITIONS AND THE CONSTRUCTION MANAGER CONCLUDES THAT MONITORING FREQUENCY CAN BE REDUCED. A BASELINE SURVEY SHALL BE PERFORMED PRIOR TO THE BEGINNING OF CONSTRUCTION. SURVEY MONITORING POINTS SHALL BE PLACED AT SOIL NAIL LEVEL ONE AT APPROXIMATELY 40 FEET ON CENTER HORIZONTALLY. A SECOND SERIES OF MONITORING POINTS SHALL BE PLACED 15 FEET FROM THE FACE OF THE SOIL NAIL WALL ON THE ADJACENT GROUND BEHIND THE WALL LOCATION.

PROCEDURE FOR SOIL NAILING

1. LINES AND GRADES ARE TO BE ESTABLISHED BY THE GENERAL CONTRACTOR TO ENSURE PROPER LOCATION OF SOIL NAIL ANCHORS.
2. EXCAVATED FACE SHALL BE TRIMMED UNIFORMLY TO A VERTICAL PLANE AT BACK FACE OF SHOTCRETE BY CONTRACTOR.
3. START EXCAVATION AND SHOTCRETE IN LIFTS NOT TO EXCEED FIVE (5) FEET OR AS OTHERWISE AUTHORIZED BY THE SHORING ENGINEER. CONTINUE THIS EXCAVATION PROCEDURE UNTIL ANCHOR LEVELS ARE REACHED.
4. THE GENERAL CONTRACTOR SHALL GRADE SAFE WORKING AND DRILLING BENCHES NOT MORE THAN THREE (3) FEET LOWER THAN THE ANCHOR LEVEL. BENCHES SHALL HAVE LENGTHS AND WIDTHS WHICH WILL ALLOW FOR SAFE AND PRODUCTIVE MOVEMENT OF THE ANCHOR DRILLING EQUIPMENT.
5. DRILL ANCHOR HOLES TO THE DEPTHS AND DIAMETERS INDICATED OR AS OTHERWISE AUTHORIZED BY THE SHORING ENGINEER. IF CAVING OCCURS, CASING OR OTHER ALTERNATE DRILLING METHODS MAY BE USED AS AUTHORIZED BY THE SHORING ENGINEER.
6. INSERT THE ANCHOR TENDONS INTO THE DRILLED SHAFTS WHILE TAKING MEASURES TO ENSURE THAT THE TENDONS ARE CENTERED (I.E. BY THE USE OF CENTRALIZING DEVICES OR OTHER MEANS ACCEPTABLE TO THE SHORING ENGINEER) IN THE DRILLED SHAFT.
7. BACKFILL THE ANCHOR LENGTH WITH A CONCRETE GROUT MIX IDENTIFIED IN MATERIALS.
8. AFTER ANCHORS HAVE BEEN PLACED, SHOTCRETE & REINFORCEMENT SHALL BE APPLIED TO THE EXCAVATED FACE. A BEARING PLATE WILL THEN BE PLACED ON THE ANCHOR AND BOLTED DOWN WITH A BEARING NUT.
9. EXCAVATE TO NEXT DRILL BENCH LOCATION AFTER SHOTCRETE HAS CURED FOR TWO (2) DAYS.
10. REPEAT STEPS 5 THROUGH 9 AS APPLICABLE FOR EACH ADDITIONAL LEVEL OF ANCHORS OR UNTIL BOTTOM OF EXCAVATION IS REACHED.

MATERIALS

1. WELDING: ELECTRIC ARC USING ELECTRODES E70-XX PLACED BY QUALIFIED WELDERS.
2. MISCELLANEOUS STEEL: STEEL SHALL CONFORM TO REQUIREMENTS OF ASTM A-36 (36 KSI) OR BETTER.
3. ANCHOR TENDON: PERMANENT NAILS: ANCHOR TENDON SHALL BE DOUBLE CORROSION PROTECTED (DCP) GRADE 75 ASTM A-615 THREADED BAR OR BETTER. SEE CROSS SECTIONS FOR BAR SIZES & LENGTHS.
4. ANCHOR CONCRETE/GROUT: ANCHOR PLUG FOR SOIL NAILS SHALL BE NEAT PORTLAND CEMENT WITH A MAXIMUM WATER-CEMENT RATIO OF 0.45 BY WEIGHT. (TYPE ⅞ CEMENT REQUIRED) IF MIX CONTAINS AN ADDITIVE TO CONTROL SHRINKAGE, SUCH AS INTRAPLAST-11 BY SIBU CORP. AND SHALL HAVE SUFFICIENT STRENGTH TO INSURE LOAD TRANSFER BETWEEN THE THREADED BAR AND SOIL. AT THE SHORING CONTRACTORS OPTION, A 3000 PSI CONCRETE @ 28 DAYS COMPRESSIVE STRENGTH MAY BE UTILIZED. NOTE: TYPE ⅞ CEMENT REQUIRED (MAX. W/C=0.45 BY WEIGHT)
5. SHOTCRETE: SHOTCRETE SHALL HAVE A MINIMUM COMPRESSIVE STRENGTH AT 28 DAYS OF 4000 PSI. (TYPE ⅞ CEMENT REQUIRED), WITH MAXIMUM WATER-CEMENT RATIO OF 0.45 BY WEIGHT. SHOTCRETE SHALL BE APPLIED BY A CERTIFIED NOZZLEMAN. SHOTCRETE CONSTRUCTION AND TESTING SHALL COMPLY WITH THE REQUIREMENTS OF CBC SECTION 1913, VOL. 2, CHAPTER 19 FOR ALL PERMANENT SHOTCRETE.
6. REINFORCING STEEL: REINFORCING STEEL SHALL BE GRADE 60 AND CONFORM TO REQUIREMENTS OF ASTM A615.
7. GEOCOMPOSITE DRAIN: GEOCOMPOSITE DRAINAGE BOARD SHALL BE MIRADRAIN 6000 BY MIRADRI (OR EQUAL).
8. WELDED WIRE FABRIC: STEEL SHALL CONFORM TO THE REQUIREMENTS OF ASTM A-1064, fy=60.0 ksi.
9. EPOXY COATING: (WHEN USED IN LIEU OF GALVANIZATION FOR ANCHOR HEAD ASSEMBLY) EPOXY COATING SHALL BE BIFUNCTIONAL COAL-TAR EPOXY TWO COATS SHALL BE APPLIED FOR A TOTAL DRY FILM THICKNESS OF 16 MILS. ALL STEEL SURFACES SHALL BE BLAST WITH SSPC-SP 10 (NEAR WHITE) BEFORE COATING IS APPLIED.
10. WELDED STUDS: STUDS SHALL BE NELSON SHEAR CONNECTOR STUDS MANUFACTURED FROM ASTM A 108, GRADES C-1010 THROUGH 1020 COLD DRAWN STEEL. STUDS SHALL BE IN CONFORMANCE WITH 1050 EVALUATION REPORT 2514.

PROCEDURE FOR SOIL NAIL TESTING

1. PERFORM A MINIMUM OF 2 PRODUCTION VERIFICATION TESTS PRIOR TO THE START OF THE NAIL WALL INSTALLATION @ 200% OF THE ALLOWABLE PULL-OUT RESISTANCE IN ACCORDANCE WITH FHWA "GEO-TECHNICAL ENGINEERING CIRCULAR No.7". IF WAYS FOR VERIFICATION NAILS ARE OVERSOLD ADEQUATELY, THEY MAY BE USED AS PART OF THE PRODUCTION NAILS.
2. PROOF TEST OR TOTAL ANCHORS (MIN. 2 ANCHORS PER ROW) @ 150% OF ALLOWABLE PULL-OUT RESISTANCE IN ACCORDANCE 150 WITH FHWA "GEO-TECHNICAL ENGINEERING CIRCULAR No.7".
3. PERFORMANCE TEST 2 ANCHORS MINIMUM IN EACH DIFFERENT ROCK/SOIL MATERIAL @ 150% OF ALLOWABLE PULL-OUT RESISTANCE IN ACCORDANCE WITH FHWA "GEO-TECHNICAL ENGINEERING CIRCULAR No.4".
4. ALLOWABLE PULL OUT RESISTANCE FOR THIS PROJECT EQUALS: 1,885 PLF (POUNDS PER LINEAL FOOT) OR 8.35 PSI
5. ALL TEST NAIL LOCATIONS TO BE DESIGNATED BY THE PROJECT'S GEO-TECHNICAL UNDERWRITER.
6. ALL TESTING TO BE PERFORMED UNDER THE SUPERVISION OF THE GEO-TECHNICAL ENGINEER'S REPRESENTATIVE.

SUMMARY OF SPECIAL INSPECTION

1 Concrete	13.1	Verify soils conditions are substantially in conformance with the soil investigation report
2 Bolts installed in concrete	13.2	Verify that foundation excavations extend to proper depth and bearing strata
3 Concrete moment-resisting space frame	13.3	Provide soil composition test results, depth of fill, relative density, bearing values
4 Reinforcing steel and prestressing steel	13.4	Provide soil expansion test results, expansion index, recommendations for foundations, on-grade floor slab design for each building site
5.1 All structural welding		
5.2 Weld testing ductile moment-resisting steel frame		
5.3 Welding reinforcing steel		
6 High-strength bolting		
7 Structural masonry		
8 Reinforced gypsum concrete	14	Special cases (describe)
9 Insulating concrete fill	15	off-site fabrication of building components
10 Spray-applied fireproofing	16	Other special inspections as required by designer (Structural Observation)
11 Deep foundations (piling & drilled caissons)		
12 Shotcrete		

Number	Description of Type of Inspection Required, Location, Remarks, etc.	Design Strength
1	Shotcrete. Verify design mix & strength.	4000 psi
2	Anchor Grout. Verify design mix & strength.	
3	Verify drilled shaft length, diameter & angle for soil nails.	
4	Verification testing of 2 anchors to 200%	
5	Performance testing of 2 anchors to 150%	
6	Placement of rebar steel & soil nails	
7	Soil Tests 13.1, 13.2, 13.3 & 13.4	
8	Proof testing 5% of total anchors to 150%	
9	Field Welds	E70-XX

- a. The Special Inspections listed are in addition to the called inspections required by the CBC, as amended. Special Inspection is not a substitute for inspection by a City Inspector.
- b. Continuous inspection is always required during the performance of the work unless otherwise specified. When work in more than one category of work requiring special inspection is to be performed simultaneously, or the geographic location of the work is such that it cannot be continuously observed in accordance with the provisions of the CBC, it is the agent's responsibility to employ a sufficient number of inspectors to assure that all the work is inspected in accordance with those provisions.
- c. The Special Inspectors listed are in addition to the City of San Diego to perform the type of inspection specified.
- d. It is the responsibility of the contractor to notify the Special Inspector or inspection agency at least one working day prior to performing any work that requires special inspection.
- e. Specially inspected work that is installed or covered without the approval of the City Inspector is subject to removal or exposure.

ES6

TORREY PINES ROAD SLOPE RESTORATION
BETWEEN LITTLE STREET AND RIDGELAND DRIVE
SAN DIEGO, CALIFORNIA

SPEC. NO. 1550

CITY OF SAN DIEGO, CALIFORNIA
ENGINEERING DEPARTMENT
SHEET 14 OF 14 SHEETS

ISSUED BY: *[Signature]* DATE: 07-12-17
DESIGNED BY: *[Signature]* DATE: *[Signature]*
CHECKED BY: *[Signature]* DATE: *[Signature]*

CONTRACTOR: *[Signature]* DATE STARTED: *[Signature]*
INSPECTOR: *[Signature]* DATE COMPLETED: *[Signature]*

32132 -14-D

TORREY PINES ROAD SLOPE RESTORATION TRAFFIC CONTROL PLANS

TRAFFIC CONTROL NOTES:

- VALIDATION: THIS TRAFFIC CONTROL PLAN IS NOT VALID UNTIL WORK DATES ARE APPROVED. THE CONTRACTOR SHALL PER SECTION 500-2(1) OF THE "HANDBOOK" CALL THE ENGINEERING TRAFFIC CONTROL SECTION AT (858) 495-4741 TO OBTAIN A PERMIT. THE CONTRACTOR MUST CALL A MINIMUM OF TWO (2) WORKING DAYS PRIOR TO STARTING WORK, OR FIVE (5) WORKING DAYS WHEN THE WORK WILL AFFECT A TRAFFIC SIGNAL.
- STANDARDS: THIS TRAFFIC CONTROL PLAN SHALL CONFORM TO THE MOST RECENTLY ADOPTED EDITION OF EACH OF THE FOLLOWING MANUALS:
 - CALTRANS MANUAL OF TRAFFIC CONTROLS FOR CONSTRUCTION AND MAINTENANCE WORK ZONES;
 - STANDARD SPECIFICATIONS FOR PUBLIC WORKS CONSTRUCTION ("GREENBOOK") AND CITY OF SAN DIEGO SUPPLEMENT AMENDMENTS;
 - STANDARD SPECIFICATIONS FOR PUBLIC WORKS CONSTRUCTION ("WHITEBOOK") AND CITY OF SAN DIEGO SUPPLEMENT AMENDMENTS.
- NOTIFICATIONS: THE CONTRACTOR SHALL NOTIFY THE FOLLOWING AFFECTED AGENCIES A MINIMUM OF FIVE (5) WORKING DAYS PRIOR TO ANY EXCAVATION, CONSTRUCTION OR TRAFFIC CONTROL:

FIRE DEPARTMENT DISPATCH (858) 573-3300	(STREET OR ALLEY CLOSURE) (858) 495-7800	(858) 573-3300
POLICE DEPARTMENT TRAFFIC UNDERGROUND SERVICE ALERT (858) 622-4033	(ANY EXCAVATION) (858) 495-7800	(858) 495-7800
WASTE MANAGEMENT DEPT. (858) 573-7500	(REFUSE COLLECTION) (858) 573-7500	(858) 573-7500
STREET DIVISION/ELECTRICAL (619) 238-0000 x424	(TRAFFIC SIGNALS) (619) 238-0000 x424	(619) 238-0000 x424
SAN DIEGO TRANSIT (619) 595-7030	(BUS STOPS) (619) 595-7030	(619) 595-7030
MTDB	(TAXI ZONES)	

THE CONTRACTOR SHALL NOTIFY PROPERTY OWNERS AND TENANTS A MINIMUM OF FIVE (5) WORKING DAYS PRIOR TO CLOSURE OF DRIVEWAYS. THE CONTRACTOR SHALL POST SIGNS NOTIFYING THE PUBLIC A MINIMUM OF FIVE (5) WORKING DAYS PRIOR TO CLOSURE OF STREETS.
- POSTING NO PARKING SIGNS: THE CONTRACTOR SHALL POST "TOW-AWAY/NO PARKING" SIGNS TWENTY-FOUR (24) HOURS IN ADVANCE FOR TEMPORARY PARKING REMOVAL. SIGNS SHALL INDICATE SPECIFIC DATES, DATES, AND TIMES OF RESTRICTIONS.
- EXCAVATIONS, EXCEPT AS SHOWN ON THE PLANS, TRENCHES SHALL BE BACKFILLED OR TRENCH-PLATED AT THE END OF EACH WORK DAY. AN ASPHALT RAMP SHALL BE PLACED AROUND EACH TRENCH PLATE TO PREVENT THE PLATE FROM BEING DISLODGED. UPON COMPLETION OF EXCAVATION BACKFILL, THE CONTRACTOR SHALL PROVIDE A SATISFACTORY SURFACE FOR TRAFFIC. WHEN CONSTRUCTION OPERATIONS ARE NOT ACTIVELY IN PROGRESS, THE CONTRACTOR SHALL MAINTAIN ALL TRAVEL LANES OPEN TO TRAFFIC EXCEPT AS SHOWN ON THE PLANS.
- RESTORATION OF TRAFFIC CONTROL DEVICES: THE CONTRACTOR SHALL REPAIR OR REPLACE TRAFFIC CONTROL DEVICES INCLUDING TRAFFIC SIGNS, STRIPES, PAVEMENT MARKERS, PAVEMENT MARKINGS, LEGS, CURB MARKINGS, LOOP DETECTORS, TRAFFIC SIGNAL EQUIPMENT, ETC. DAMAGED OR REMOVED AS A RESULT OF OPERATIONS AND NOT DESIGNED FOR REMOVAL, REPAIRS AND REPLACEMENTS SHALL BE EQUAL TO EXISTING IMPROVEMENTS. LOOP DETECTORS SHALL BE REPLACED WITHIN THREE (3) WORKING DAYS OF COMPLETION OF UNDERGROUND WORK.
- CHANGES IN WORK: THE RESIDENT ENGINEER WILL OBSERVE THESE TRAFFIC CONTROL PLANS IN OPERATION AND RESERVES THE RIGHT TO MAKE CHANGES AS THE FIELD CONDITIONS WARRANT. SUCH CHANGES SHALL SUPERSEDE THESE PLANS.
- FOR WORK NOT COVERED BY THESE TRAFFIC CONTROL PLANS, THE CONTRACTOR SHALL PER SECTION 7-10.2.2 OF THE CONTRACT SPECIAL PROVISIONS, PREPARE TRAFFIC CONTROL WORKING DRAWINGS AND SUBMIT THEM TO THE RESIDENT ENGINEER. THE CONTRACTOR SHALL ALLOW A MINIMUM OF TWENTY (20) WORKING DAYS FOR REVIEW OF THE WORKING DRAWINGS. UPON APPROVAL OF THE TRAFFIC CONTROL PLAN, THE ENGINEERING TRAFFIC CONTROL SECTION WILL ISSUE A TRAFFIC CONTROL PLAN (TCP) PERMIT FOR THE WORK.

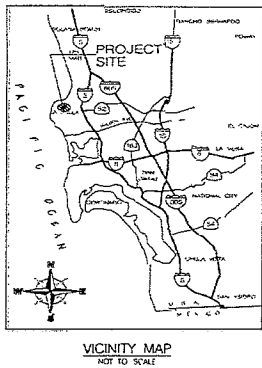

TRAFFIC CONTROL SIGNS (TYP)

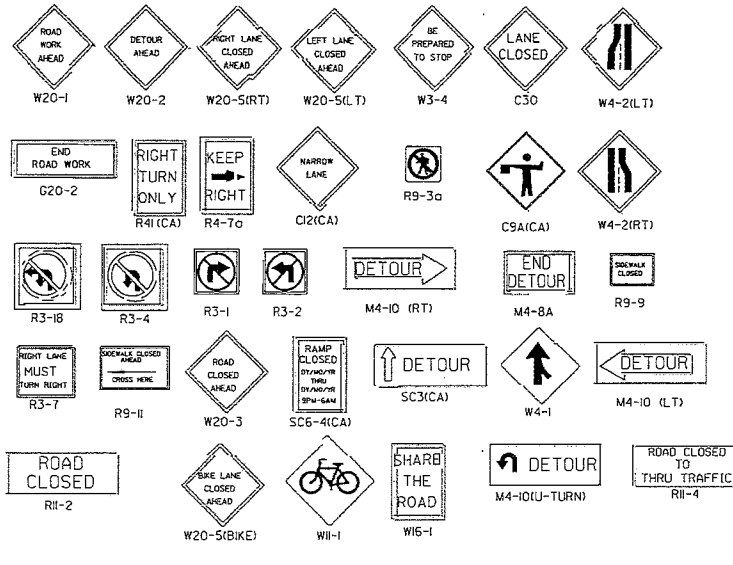

NOTE: ALL SIGNS ARE STANDARD SIZE

TRAFFIC CONTROL 85TH PERCENTILE SPEED

TORREY PINES RD _____ 47 MPH

CONTINUOUS SETUP

TABLE 1

RECOMMENDED SIGN SPACING FOR ADVANCE WARNING SIGN SERIES, BUFFER, TAPER LENGTH AND DEVICE SPACING.

APPROACH SPEED (MPH)	MINIMUM DISTANCE IN FEET BETWEEN SIGNS AND FROM LAST SIGN TO TAPER	Shoulder		
		Merging L (feet)	Shifting L/2 (feet) (TANGENT)	L/3 (feet)
25	150-200	125	65	45
30	200-300	180	90	60
35	250-400	245	125	85
40	350-500	320	160	110
45	500-750	540	270	180
50	500-1000	600	300	200
55+	500-1500	660	330	220

* L=WS /60 FOR SPEED OF 40 MPH OR LESS; L=WS FOR SPEED GREATER THAN 40 MPH. TAPER LENGTHS SHOWN ARE ROUNDED TO NEAREST 5 FEET.

D BUFFER	E MAXIMUM DEVICE SPACING IN FEET	NOTE:	
		TAPER FORMULA	L = S x W for speeds greater than 40 mph
55	25	$L = \frac{W \times S^2}{60}$	for speeds of 40 mph or less
85	30		
120	35		
170	40		
220	45		
280	50		
335+	50		

Where:
L = minimum length of taper
S = numerical value of APPROACH speed prior to work (mph)
W = width of offset (feet)

LEGEND

DELINEATOR OR CONE	•
SIGN	+
TRAFFIC DIRECTIONAL ARROW	→
WORKING AREA	▨
FLASHING ARROW BOARD	⊠
BARRICADE	I
PF8 (PORTABLE FLASHING BEACON)	⊞
CAUTION BOARD	⊞

MAINTENANCE CHECKED: _____ DATE: 09-07-17
 TORREY PINES ROAD SLOPE RESTORATION
 TRAFFIC CONTROL PLANS

CITY OF SAN DIEGO, CALIFORNIA PUBLIC WORKS DEPARTMENT
 SHEET 7 OF 33 SHEETS
 WBS 5-00877
 PROJECT MANAGER: JASON GUSSE
 PROJECT ENGINEER: CORSON SMITH
 DATE: 9/11/2017
 250-1689
 1890-6250
 32132-T-D

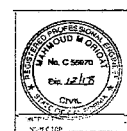

TORREY PINES ROAD SLOPE RESTORATION

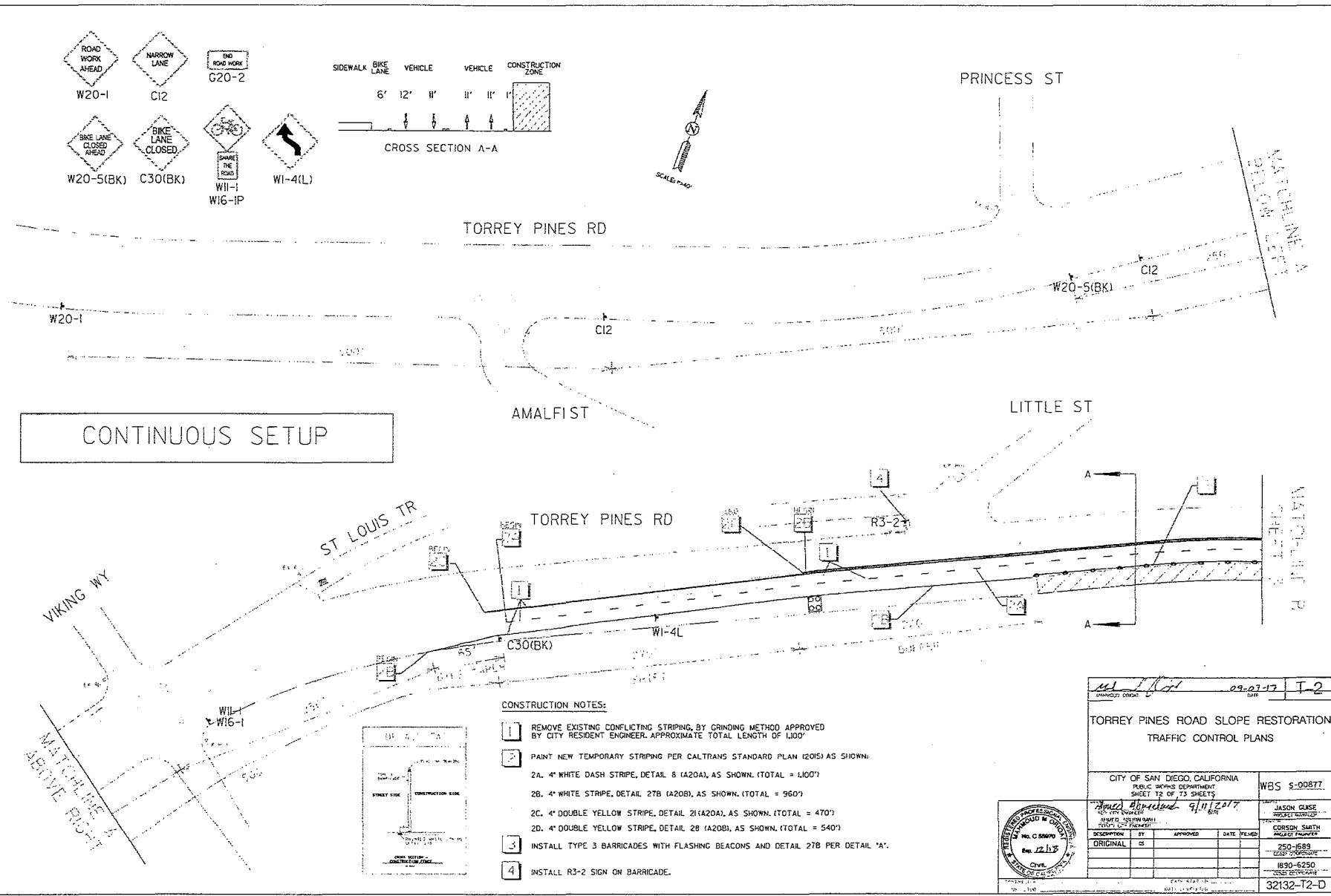
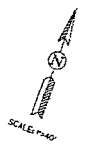
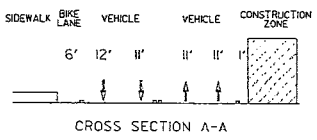
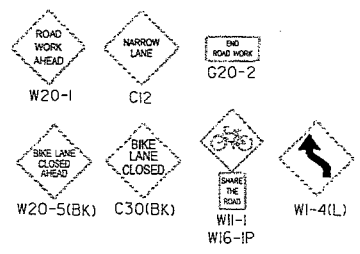

- CONSTRUCTION NOTES:**
- 1 REMOVE EXISTING CONFLICTING STRIPING, BY GRINDING METHOD APPROVED BY CITY RESIDENT ENGINEER. APPROXIMATE TOTAL LENGTH OF 1100'
 - 2 PAINT NEW TEMPORARY STRIPING PER CALTRANS STANDARD PLAN (2005) AS SHOWN:
 - 2A. 4" WHITE DASH STRIPE, DETAIL B (A20A), AS SHOWN. (TOTAL = 1100')
 - 2B. 4" WHITE STRIPE, DETAIL 2B (A20B), AS SHOWN. (TOTAL = 960')
 - 2C. 4" DOUBLE YELLOW STRIPE, DETAIL 2C (A20A), AS SHOWN. (TOTAL = 470')
 - 2D. 4" DOUBLE YELLOW STRIPE, DETAIL 2B (A20B), AS SHOWN. (TOTAL = 540')
 - 3 INSTALL TYPE 3 BARRICADES WITH FLASHING BEACONS AND DETAIL 27B PER DETAIL 'A'.
 - 4 INSTALL R3-2 SIGN ON BARRICADE.

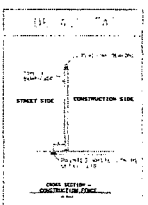

DATE: 09-01-17		T-2	
TORREY PINES ROAD SLOPE RESTORATION TRAFFIC CONTROL PLANS			
CITY OF SAN DIEGO, CALIFORNIA PUBLIC WORKS DEPARTMENT SHEET 12 OF 13 SHEETS		WBS S-08877	
DESIGNED BY: <i>Ames</i>	DATE: 9/1/2017	PROJECT MANAGER: JASON GUSE	PROJECT NUMBER: WBS S-08877
APPROVED BY: <i>[Signature]</i>	DATE: 12/17	DESIGNED BY: CORSON SMITH	PROJECT NUMBER: 250-1589
ORIGINAL: ES	APPROVED: []	DATE FILED: []	PROJECT NUMBER: 1890-6250
CIVIL ENGINEER		PROJECT NUMBER: 32132-T2-D	

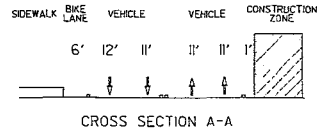

CONTINUOUS SETUP

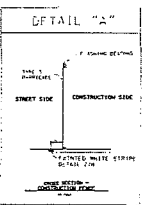
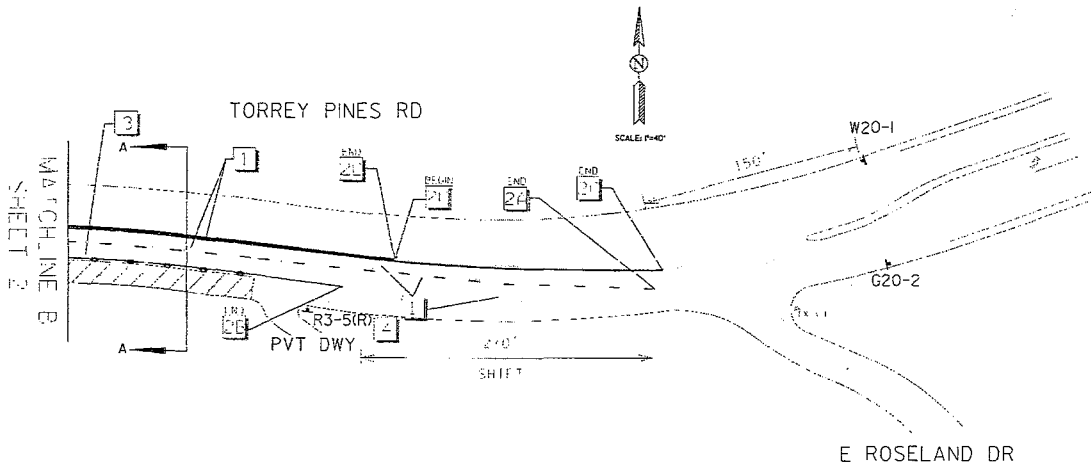

CONSTRUCTION NOTES:

- 1 REMOVE EXISTING CONFLICTING STRIPING PER METHOD APPROVED BY CITY RESIDENT ENGINEER. APPROXIMATE TOTAL LENGTH OF 1100'
- 2 PAINT NEW TEMPORARY STRIPING PER CALTRANS STANDARD PLAN (2015) AS SHOWN:
 - 2A. 4" WHITE DASH STRIPE, DETAIL B (A20A), AS SHOWN, (TOTAL = 1100')
 - 2B. 4" WHITE STRIPE, DETAIL 27B (A20B), AS SHOWN, (TOTAL = 960')
 - 2C. 4" DOUBLE YELLOW STRIPE, DETAIL 21(A20A), AS SHOWN, (TOTAL = 470')
 - 2D. 4" DOUBLE YELLOW STRIPE, DETAIL 28 (A20B), AS SHOWN, (TOTAL = 540')
- 3 INSTALL TYPE 3 BARRICADES WITH FLASHING BEACONS AND DETAIL 27B PER DETAIL 'A'.
- 4 INSTALL R3-5(R) SIGN.

 DATE: 09-07-17 SHEET NO: T-3	
TORREY PINES ROAD SLOPE RESTORATION TRAFFIC CONTROL PLANS	
CITY OF SAN DIEGO, CALIFORNIA PUBLIC WORKS DEPARTMENT SHEET T3 OF T3 SHEETS WBS S-00877	
PROJECT ENGINEER JAMES ALURAMAMANI (951) 594-1113	PROJECT MANAGER JASON CURSE (619) 451-1222
DESCRIPTION ORIGINAL ES	DATE FILMED 9/11/2017 250-1688 1890-6250 32132-T3-D

Bid Results

Bidder Details

Vendor Name Hazard Construction Company
Address 6465 Marindustry Drive
 San Diego, CA 92121
 United States

Respondee Kurt Hindman
Respondee Title Vice President
Phone 858-200-3660 Ext.
Email khindman@hazardcon.com
Vendor Type CAU,MALE,PQUAL,CADIR,Local
License # 750542
CADIR 1000022121

Bid Detail

Bid Format Electronic
Submitted October 26, 2017 1:55:00 PM (Pacific)
Delivery Method
Bid Responsive
Bid Status Submitted
Confirmation # 120865
Ranking 0

Respondee Comment

Buyer Comment

Attachments

File Title	File Name	File Type
Hazard Cert of Pending Action	Certification of Pending Action.pdf	Contractor's Certification of Pending Actions
Hazard Bid Bond	Bid Bond.pdf	Bid Bond

Line Items

Type	Item Code	UOM	Qty	Unit Price	Line Total	Comment Reference
Main Bid Torrey Pines Rd						
1	Bonds (Payment and Performance)					
	524126	LS	1	\$10,000.00	\$10,000.00	2-4.1
2	Video Recording of Existing Conditions					
	238990	LS	1	\$1,000.00	\$1,000.00	7-9.1.1
3	WPCP Implementation					
	237990	LS	1	\$10,000.00	\$10,000.00	7-8.6.4.2
4	WPCP Development					
	541330	LS	1	\$1,000.00	\$1,000.00	7-8.6.4.2
5	Field Orders - Type II					
		AL	1	\$45,000.00	\$45,000.00	9-3.5

Bid Results

Type	Item Code	UOM	Qty	Unit Price	Line Total	Comment Reference
6	Clearing and Grubbing					
	238910	LS	1	\$50,000.00	\$50,000.00	300-1.4
7	Adjust Existing Sewer Manhole Frame and Cover to Grade (Behind the Curb)					
	237310	EA	1	\$1,000.00	\$1,000.00	301-1.7
8	Adjust Existing Storm Drain Cleanout Frame and Cover to Grade (Behind the Curb)					
	237310	EA	1	\$1,000.00	\$1,000.00	301-1.7
9	Adjust Existing Water Meter to Grade					
	237310	EA	4	\$500.00	\$2,000.00	301-1.7
10	Adjust Existing Water Gate Valve Frame and Cover to Grade (Behind the Curb)					
	237310	EA	1	\$750.00	\$750.00	301-1.7
11	Adjust Existing Electrical Box to Grade					
	237310	EA	2	\$300.00	\$600.00	301-1.7
12	Adjust Existing Communication Cabinet to Grade					
	237310	EA	1	\$1,000.00	\$1,000.00	301-1.7
13	Cold Mill AC Pavement (2 inch)					
	237310	SF	170000	\$0.30	\$51,000.00	302-1.12
14	Asphalt Concrete Overlay (2 inch) including Loop Detector Replacements					
	237310	TON	2000	\$100.00	\$200,000.00	302-5.9.2
15	Asphalt Concrete (For Existing Median Removal)					
	237310	LS	1	\$5,000.00	\$5,000.00	302-5.9.1
16	Gravity Retaining Wall (30 inch, Type A)					
	238110	LF	45	\$250.00	\$11,250.00	303-1.11
17	Masonry Retaining Wall (Type II)					
	238110	SF	390	\$80.00	\$31,200.00	303-4.1.5
18	Masonry Retaining Wall (Type III)					
	238110	SF	140	\$85.00	\$11,900.00	303-4.1.5
19	Concrete Monolithic Curb (6 inch)					
	238110	LF	75	\$50.00	\$3,750.00	303-5.9
20	Concrete Monolithic Curb (12 inch)					
	238110	LF	115	\$50.00	\$5,750.00	303-5.9
21	Sidewalk					
	237310	SF	2600	\$7.00	\$18,200.00	303-5.9

Bid Results

Type	Item Code	UOM	Qty	Unit Price	Line Total	Comment	Reference
22	Curb and Gutter (6 inch Curb, Type G)						
	237310	LF	130	\$75.00	\$9,750.00		303-5.9
23	Cross Gutter						
	237310	SF	435	\$25.00	\$10,875.00		303-5.9
24	Concrete Driveway (Contiguous)						
	237310	SF	890	\$15.00	\$13,350.00		303-5.9
25	Curb Ramp Modified (Type D) with Detectable Warning Tiles						
	237310	EA	2	\$3,500.00	\$7,000.00		303-5.10.2
26	Curb Ramp Modified (Type C1) with Detectable Warning Tiles						
	237310	EA	2	\$3,500.00	\$7,000.00		303-5.10.2
27	Colored Stamped Asphalt Concrete						
	237310	SF	11340	\$7.50	\$85,050.00		302-5.11.8
28	Sidewalk Underdrain Pipe (3 inch)						
	237110	LF	12	\$80.00	\$960.00		306-15.1
29	Relocate Fire Hydrant						
	237110	EA	1	\$7,500.00	\$7,500.00		306-15.6
30	Traffic Striping, Curb and Pavement Markings						
	237310	LS	1	\$16,000.00	\$16,000.00		314-4.3.7
31	Thermoplastic Traffic Striping						
	237310	LS	1	\$4,500.00	\$4,500.00		314-4.4.6
32	Traffic Control						
	237310	LS	1	\$80,000.00	\$80,000.00		601-6
33	Remove and Reinstall Traffic Signs						
	238210	EA	5	\$250.00	\$1,250.00		701-2
34	Pedestrian Barricade						
	237310	EA	8	\$500.00	\$4,000.00		701-2
35	Hawk Traffic Signal and Street Lighting System						
	238210	EA	2	\$72,000.00	\$144,000.00		701-2
36	SDG&E Fee (EOC Type I)						
	238210	AL	1	\$1,500.00	\$1,500.00		701-2
37	Relocate Irrigation System						
	561730	LS	1	\$10,000.00	\$10,000.00		801-8
					Subtotal	\$864,135.00	

Bid Results

Type	Item Code	UOM	Qty	Unit Price	Line Total	Comment Reference
	Main Bid Torrey Pines Wall					
38	Mobilization					
	237990	LS	1	\$150,000.00	\$150,000.00	9-3.4.1
39	Clearing and Grubbing					
	238910	LS	1	\$57,000.00	\$57,000.00	300-1.4
40	Traffic Control					
	237310	LS	1	\$81,000.00	\$81,000.00	601-6
41	Structural Excavation					
	237310	CY	560	\$200.00	\$112,000.00	300-3.6
42	Soil Nailing - 33' Deep					
	237990	EA	7	\$1,100.00	\$7,700.00	305-3.5
43	Soil Nailing - 36' Deep					
	237990	EA	28	\$1,200.00	\$33,600.00	305-3.5
44	Soil Nailing - 40' Deep					
	237990	EA	230	\$1,400.00	\$322,000.00	305-3.5
45	Soil Nail Testing-Verification Tests					
	237990	EA	2	\$7,000.00	\$14,000.00	305-3.5
46	Soil Nail Testing-Proof Tests					
	237990	EA	14	\$300.00	\$4,200.00	305-3.5
47	Soil Nail Testing-Performance Tests					
	237990	EA	2	\$300.00	\$600.00	305-3.5
48	4" minimum Shotcrete-Primary Structural Fascia & Rebar/WWM					
	238110	CY	98	\$2,200.00	\$215,600.00	305-3.5
49	10" minimum Thick Shotcrete-Rebar & Misc Metal Works for Arch Fascia					
	238110	CY	246	\$900.00	\$221,400.00	305-3.5
50	Sculpted Rock Finish and Stained					
	237990	SF	8000	\$25.00	\$200,000.00	305-3.5
51	Structural Backfill					
	237990	CY	35	\$100.00	\$3,500.00	305-3.5
52	12" Wide by 6" Deep Concrete Brow Ditch					
	237110	LF	340	\$50.00	\$17,000.00	303-1.11
53	Concrete Stone Channel Outlet - Private Dr					
	237110	EA	1	\$2,000.00	\$2,000.00	303-1.11

Bid Results

Type	Item Code	UOM	Qty	Unit Price	Line Total	Comment	Reference
54	Cable and Rail Post - 42" High						
	237990	LF	350	\$40.00	\$14,000.00		305-3.5
55	Water Main Ductile Iron (8 Inch, Class 350)						
	237110	LF	340	\$275.00	\$93,500.00		306-15.1
56	Ductile Iron Water Pipeline Corrosion Protection						
	237110	LS	1	\$15,000.00	\$15,000.00		306-15.13
57	Cutoff Wall (WP-07)						
	237110	EA	3	\$3,000.00	\$9,000.00		303-1.11
58	Construct Wall Drain System						
	237990	LS	1	\$5,000.00	\$5,000.00		305-3.5
59	Video Recording of Existing Conditions						
	238990	LS	1	\$1,000.00	\$1,000.00		7-9.1.1
60	Anti-Graffiti Coating						
	237990	SF	8000	\$2.00	\$16,000.00		305-3.5
61	Finish Grading at Bottom of Wall (EOC Type I)						
	237310	AL	1	\$4,000.00	\$4,000.00		300-2.9
62	Asphalt Pavement Repair						
	237310	SF	4000	\$5.00	\$20,000.00		302-3.2
63	Removal or Abandonment of Existing Water Facilities						
	237110	LS	1	\$3,000.00	\$3,000.00		306-3.3.3
64	Removal of Traffic Striping and Curb Markings						
	237310	LS	1	\$7,000.00	\$7,000.00		314-2.3
65	Site Storage and Handling of Construction and Demolition Waste						
	238910	LS	1	\$5,000.00	\$5,000.00		7-21.9
66	WPCP Development						
	541330	LS	1	\$1,000.00	\$1,000.00		7-8.6.4.2
67	WPCP Implementation						
	237990	LS	1	\$19,000.00	\$19,000.00		7-8.6.4.2
68	Field Orders (EOC Type II)						
		AL	1	\$150,000.00	\$150,000.00		9-3.5
69	Bonds (Payment and Performance)						
	524126	LS	1	\$20,000.00	\$20,000.00		2-4.1

Bid Results

Type	Item Code	UOM	Qty	Unit Price	Line Total	Comment Reference
70	Pavement Restoration for Final Connection					
	237110	SF	200	\$20.00	\$4,000.00	901-2.5
Subtotal					\$1,828,100.00	
Total					\$2,692,235.00	

Subcontractors

Name & Address	Description	License Num	CADIR	Amount	Type
Anton's Service, Inc. 8865 Winter Gardens Blvd Lakeside, CA 92040 United States	Clearing/Demolition Constructor	861069	1000002533	\$60,249.00	CAU,MALE,SDB,SLBE
Terra West, Inc 591 Telegraph Canyon Rd #713 Chula Vista, CA 91910 United States	Water Pollution Control Program Development - Consultant	N/A	1000007319	\$1,100.00	ELBE,DBE
Ludwig Masonry 13631 Putney Road Poway, CA 92064 United States	Masonry Constructor	943777	1000010532	\$43,100.00	ELBE
Shariden Design Asphalt, Inc. P.O. Box 285 Alpine, CA 91903 United States	Colored Stamped AC Constructor	760168	1000010142	\$79,947.00	
Payco Specialties Inc. 120 North Second Ave Chula Vista, CA 91910 United States	Striping/Sign Constructor	298637	1000003515	\$34,985.00	CAU,FEM,PQUAL,SLBE,MBE,SDB,WBE,WOSB
SRK Engineering, INC 494 Ocean View Dr. Vista, CA 92084 United States	Waterline Constructor	10173836	1000027656	\$111,200.00	PAC,FEM,ELBE,DBE,MBE,SDB,WBE,WOSB
Sutherlin Contracting, Inc. 2007 Muira Lane El Cajon, CA 92019 United States	ELECTRICAL CONSTRUCTOR	787127	1000008101	\$146,000.00	PQUAL,SLBE
QSB Construction 365 W. Second Ave ste 215 Escondido, CA 92025 United States	Concrete flatwork, ditch, permanent shotcrete and sculpted rock finish.	956107	1000004298	\$436,984.00	LAT,FEM,PQUAL,SLBE,DBE,MBE,CADIR,WBE
Acme Safety & Supply Corp. 1616 West Ave.,San Diego, CA, 91950 San Diego, CA 91950 United States	Traffic Control Constructor	791667	1000007958	\$75,000.00	DBE,SDB,SLBE,WOSB
Condon Johnson 9685 Via Excelencia Suite 106 San Diego, CA 92126 United States	SOIL NAILS AND SHOTCRETE (PARTIAL) CONSTRUCTOR	300068	1000004443	\$590,650.00	