

City of San Diego

CONTRACTOR'S NAME: TC Construction Company, Inc.
ADDRESS: 10540 Prospect Ave., Santee, CA 92071
TELEPHONE NO.: 619 448-4560 **FAX NO.:** 619 619 258-9751
CITY CONTACT: Michelle Muñoz **Contract Specialist, Email:** MichelleM@sandiego.gov
Phone No. (619) 533-3482, **Fax No.** (619) 533-3633
M. Gonzalez / A. Rekani / LJI

CONTRACT DOCUMENTS

ORIGINAL



FOR

**SOLE-SOURCE CONSTRUCTION SERVICES FOR
REPAIRS AT A STORM DRAINAGE PIPE AT
2582 MANZANA WAY**

BID NO.: K-17-6865-SLS-1
SAP NO. (WBS/IO/CC): B-17079
CLIENT DEPARTMENT: 2116
COUNCIL DISTRICT: 4
PROJECT TYPE: CB

ENGINEER OF WORK

The engineering Specifications and Special Provisions contained herein have been prepared by or under the direction of the following Registered Engineer:



For City Engineer

12-13-16
Date

Seal:



ORIGINAL

TABLE OF CONTENTS

DESCRIPTION	PAGE NUMBER
1. GENERAL	4
2. AGREEMENT	11
3. EXHIBITS	
• Exhibit A - Drug-Free Workplace Certification.....	16
• Exhibit B - ADA Compliance Certification	18
• Exhibit C - Contractor Standards - Pledge of Compliance.....	20
• Exhibit D - Affidavit of Disposal	22
• Exhibit E - Non-Collusion Affidavit.....	24
• Exhibit F - Contractors Certification Of Pending Actions	26
• Exhibit G - Equal Benefits Ordinance Certification of Compliance	28
• Exhibit H - Forms.....	30
• Exhibit I - Supplementary Special Provisions (SSP)	33
• Exhibit J - Proposal	42
• Exhibit K - Contractor's Compensation Rate Schedule	46
• Exhibit L - Notice of Exemption	61
• Exhibit M - Location Map	64
• Exhibit N - Storm Water Applicability Checklist (DS-560).....	66
• Exhibit O - Advanced Metering Infrastructure (AMI) Device Protection	71

CITY OF SAN DIEGO, CALIFORNIA

GENERAL

1. DESCRIPTION OF WORK:

- 1.1. The Work involves furnishing all labor, materials, equipment, services, and other incidental works and appurtenances for the purpose of designing and constructing this project at the direction of the City Engineer.
- 1.2. The Work consists of replacing the existing 18-inch CMP storm drain approximately 85 feet in length with 18-inch HDPE pipe within the existing City easement. Construction will include, but not limited to construction of cleanouts, repair of slope after pipe installation, and filling of sinkhole to pre-emergency grade and compaction.
- 1.3. This solicitation is for a "Time-and-Materials" contract in accordance with the provisions set forth in 3-2.4, "Agreed Prices" of The GREENBOOK.
- 1.4. A time-and-materials contract provides for acquiring labor, material, equipment and services that shall be paid for in accordance with 3-3, "EXTRA WORK" of The GREENBOOK and as modified by The WHITEBOOK.

2. CONTRACTOR REGISTRATION AND ELECTRONIC REPORTING SYSTEM:

- 2.1. **Prior** to the Award of the Contract or each Task Order, you and your Subcontractors and Suppliers must register with the City's web-based vendor registration and bid management system, BidsOnline™ hosted by PlanetBids System. For additional information go to:

<http://www.sandiego.gov/purchasing/bids-contracts/vendorreg.shtml>.

- 2.2. The City may not award the contract until registration of all subcontractors and suppliers is complete. In the event this requirement is not met within the time frame specified in the Notice of Intent to Award letter, the City reserves the right to rescind the Notice of Award / Intent to Award and to make the award to the next responsive and responsible bidder / proposer.

3. EQUAL OPPORTUNITY.

- 3.1. For the City's Equal Opportunity Program requirements see Part 10 of the City of San Diego 2015 Whitebook and Exhibit I Supplementary Special Provisions.

4. **CONTRACT TIME:** The Work shall be completed within **106 Working Days** from the date of issuance of the NTP unless extended by the Engineer.

5. **CONTRACT PRICE:** The Engineer's Estimate of the Contract Price is **\$100,000**. The Contractor shall not perform Work that exceeds the Engineer's Estimate excluding Allowances without prior written notice from the Engineer that sufficient additional funding has been secured.
6. **CONTRACTOR'S LICENSE CLASSIFICATION:** In accordance with the provisions of California Law, the Contractor shall possess valid appropriate license(s) at the time of award. The City has determined the following licensing classification(s) for this contract: Class A.
7. **PREVAILING WAGE RATES:** Pursuant to San Diego Municipal Code section 22.3019, construction, alteration, demolition, repair and maintenance work performed under this Contract is subject to State prevailing wage laws. For construction work performed under this Contract cumulatively exceeding \$25,000 and for alteration, demolition, repair and maintenance work performed under this Contract cumulatively exceeding \$15,000, the Contractor and its subcontractors shall comply with State prevailing wage laws including, but not limited to, the requirements listed below.
 - 7.1. **Compliance with Prevailing Wage Requirements.** Pursuant to sections 1720 through 1861 of the California Labor Code, the Contractor and its subcontractors shall ensure that all workers who perform work under this Contract are paid not less than the prevailing rate of per diem wages as determined by the Director of the California Department of Industrial Relations (DIR). This includes work performed during the design and preconstruction phases of construction including, but not limited to, inspection and land surveying work.
 - 7.1.1. Copies of such prevailing rate of per diem wages are on file at the City and are available for inspection to any interested party on request. Copies of the prevailing rate of per diem wages also may be found at <http://www.dir.ca.gov/OPRL/DPreWageDetermination.htm>. Contractor and its subcontractors shall post a copy of the prevailing rate of per diem wages determination at each job site and shall make them available to any interested party upon request.
 - 7.1.2. The wage rates determined by the DIR refer to expiration dates. If the published wage rate does not refer to a predetermined wage rate to be paid after the expiration date, then the published rate of wage shall be in effect for the life of this Contract. If the published wage rate refers to a predetermined wage rate to become effective upon expiration of the published wage rate and the predetermined wage rate is on file with the DIR, such predetermined wage rate shall become effective on the date following the expiration date and shall apply to this Contract in the same manner as if it had been published in said publication. If the predetermined wage rate refers to one or more additional expiration dates with additional predetermined wage rates, which expiration dates occur during the life of this Contract, each successive predetermined wage rate shall apply to this Contract on the date following the expiration date of the previous wage rate. If the last of such

predetermined wage rates expires during the life of this Contract, such wage rate shall apply to the balance of the Contract.

- 7.2. Penalties for Violations.** Contractor and its subcontractors shall comply with California Labor Code section 1775 in the event a worker is paid less than the prevailing wage rate for the work or craft in which the worker is employed.
- 7.3. Payroll Records.** Contractor and its subcontractors shall comply with California Labor Code section 1776, which generally requires keeping accurate payroll records, verifying and certifying payroll records, and making them available for inspection. Contractor shall require its subcontractors to also comply with section 1776. Contractor and its subcontractors shall submit weekly certified payroll records online via the City's web-based Labor Compliance Program. Contractor is responsible for ensuring its subcontractors submit certified payroll records to the City.
 - 7.3.1.** For contracts entered into on or after April 1, 2015, Contractor and their subcontractors shall furnish records specified in Labor Code section 1776 directly to the Labor Commissioner in the manner required by Labor Code section 1771.4.
- 7.4. Apprentices.** Contractor and its subcontractors shall comply with California Labor Code sections 1777.5, 1777.6 and 1777.7 concerning the employment and wages of apprentices. Contractor is held responsible for the compliance of their subcontractors with sections 1777.5, 1777.6 and 1777.7.
- 7.5. Working Hours.** Contractor and their subcontractors shall comply with California Labor Code sections 1810 through 1815, including but not limited to: (i) restrict working hours on public works contracts to eight hours a day and forty hours a week, unless all hours worked in excess of 8 hours per day are compensated at not less than 1½ times the basic rate of pay; and (ii) specify penalties to be imposed on design professionals and subcontractors of \$25 per worker per day for each day the worker works more than 8 hours per day and 40 hours per week in violation of California Labor Code sections 1810 through 1815.
- 7.6. Required Provisions for Subcontracts.** Contractor shall include at a minimum a copy of the following provisions in any contract they enter into with a subcontractor: California Labor Code sections 1771, 1771.1, 1775, 1776, 1777.5, 1810, 1813, 1815, 1860 and 1861.

7.7. Labor Code Section 1861 Certification. Contractor in accordance with California Labor Code section 3700 is required to secure the payment of compensation of its employees and by signing this Contract, Contractor certifies that "I am aware of the provisions of Section 3700 of the California Labor Code which require every employer to be insured against liability for workers' compensation or to undertake self-insurance in accordance with the provisions of that code, and I will comply with such provisions before commencing the performance of the work of this Contract."

7.8. Labor Compliance Program. The City has its own Labor Compliance Program authorized in August 2011 by the DIR. The City will withhold contract payments when payroll records are delinquent or deemed inadequate by the City or other governmental entity, or it has been established after an investigation by the City or other governmental entity that underpayment(s) have occurred. For questions or assistance, please contact the City of San Diego's Equal Opportunity Contracting Department at 619-236-6000.

7.9. Contractor and Subcontractor Registration Requirements. This project is subject to compliance monitoring and enforcement by the DIR. As of March 1, 2015, no contractor or subcontractor may be listed on a bid or proposal for a public works project unless registered with the DIR pursuant to Labor Code section 1725.5. As of April 1, 2015, a contractor or subcontractor shall not be qualified to bid on, be listed in a bid proposal, or enter into any contract for public work, unless currently registered and qualified to perform public work pursuant to Labor Code section 1725.5. By submitting a bid or proposal to the City, Contractor is certifying that he or she has verified that all subcontractors used on this public work project are registered with the DIR in compliance with Labor Code sections 1771.1 and 1725.5, and Contractor shall provide proof of registration to the City upon request.

7.9.1. A Contractor's inadvertent error in listing a subcontractor who is not registered pursuant to Labor Code section 1725.5 in response to a solicitation shall not be grounds for filing a bid protest or grounds for considering the bid non-responsive provided that any of the following apply: (1) the subcontractor is registered prior to bid opening; (2) within twenty-four hours after the bid opening, the subcontractor is registered and has paid the penalty registration fee specified in Labor Code section 1725.5; or (3) the subcontractor is replaced by another registered subcontractor pursuant to Public Contract Code section 4107.

8. REFERENCE STANDARDS: Except as otherwise noted or specified, the Work shall be completed in accordance with the following standards:

Title	Edition	Document Number
Standard Specifications for Public Works Construction ("The GREENBOOK") http://www.greenbookspecs.org/	2015	PWPI070116-01
City of San Diego Standard Specifications for Public Works Construction ("The WHITEBOOK")* https://www.sandiego.gov/publicworks/edocref/greenbook	2015	PWPI070116-02
City of San Diego Standard Drawings* https://www.sandiego.gov/publicworks/edocref/standarddraw	2016	PWPI070116-03
Citywide Computer Aided Design and Drafting (CADD) Standards https://www.sandiego.gov/publicworks/edocref/drawings	2016	PWPI092816-04
California Department of Transportation (CALTRANS) Standard Specifications - http://www.dot.ca.gov/des/oe/construction-contract-standards.html	2015	PWPI092816-05
CALTRANS Standard Plans - http://www.dot.ca.gov/des/oe/construction-contract-standards.html	2015	PWPI092816-06
California Manual on Uniform Traffic Control Devices Revision 1 (CA MUTCD Rev 1) - http://www.dot.ca.gov/trafficops/camutcd/	2014	PWPI092816-07
NOTE: *Available online under Engineering Documents and References at: http://www.sandiego.gov/publicworks/edocref/index.shtml		

9. **PREQUALIFICATION OF CONTRACTORS:** The contractor must be pre-qualified for the City estimated Contract Price prior to Award. For additional information or the answer to questions about the prequalification program, please contact David Stucky at 619-533-3474 or dstucky@sandiego.gov.
10. **INSURANCE REQUIREMENTS:**
- 10.1. All certificates of insurance and endorsements required by the contract are to be provided upon issuance of the City's Notice of Intent to Award letter.
- 10.2. Refer to sections 7-3, "LIABILITY INSURANCE", and 7-4, "WORKERS' COMPENSATION INSURANCE" of the Supplementary Special Provisions (SSP) for the insurance requirements which must be met.
11. **SUBMITTAL OF "OR EQUAL" ITEMS:** See 4-1.6, "Trade Names or Equals."
12. **AWARD:** The Award of this contract is contingent upon the Contractor's compliance with all conditions precedent to Award, including the submittal of acceptable insurance and surety bonds pursuant to San Diego Municipal Code §22.3007.

This contract is deemed to be awarded, and effective, only upon the signing of the Contract by the Mayor or designee of the City.

13. **SUBCONTRACT LIMITATIONS:** The Bidder's attention is directed to Standard Specifications for Public Works Construction, Section 2-3, "SUBCONTRACTS" which requires the Contractor to perform not less than the amount therein stipulated with its own forces. Failure to comply with these requirements shall render the Bid non-responsive and ineligible for award.
14. **SAN DIEGO BUSINESS TAX CERTIFICATE:** All Contractors, including Subcontractors, not already having a City of San Diego Business Tax Certificate for the work contemplated shall secure the appropriate certificate from the City Treasurer, Civic Center Plaza, first floor, before the Contract can be executed.
15. **PROPOSAL FORMS:** The signature of each person signing shall be in longhand.
16. **AWARD OF CONTRACT OR REJECTION OF BIDS:**
 - 16.1. Pursuant to San Diego Municipal Code § 22.3016, this contract may be awarded to a contractor without competitive bidding when strict compliance with a competitive process would be unavailing or would not produce an advantage, and when soliciting bids or proposals would therefore be undesirable, impractical, or impossible.
 - 16.2. The City of San Diego reserves the right to reject the proposal from the contractor when such rejection is in the best interest of the City.
17. **THE CONTRACT:** The Contractor shall execute a written contract with the City of San Diego and furnish good and approved bonds and insurance documents specified in 2-4, "CONTRACT BONDS," 7-3, "LIABILITY INSURANCE," and 7-4 WORKERS' COMPENSATION INSURANCE within **10 Working Days** after receipt by the Contractor of a form of contract for execution unless an extension of time is granted to the Contractor in writing. Bonds shall be in amount of the Contract Price for the Work included in the Bid.

The Contract shall be made in the form adopted by the City, which includes the provision that no claim or suit whatsoever shall be made or brought by Contractor against any officer, agent, or employee of the City for or on account of anything done or omitted to be done in connection with this contract, nor shall any such officer, agent, or employee be liable hereunder. If the Contractor fails to enter into the contract as herein provided, the award may be annulled. An award may be made to the next contractor on the shortlist who shall fulfill every stipulation embraced herein as if it were the party to whom the first award was made.

The Contractor shall furnish evidence of its corporate existence and evidence that the officer signing the Contract and bond for the corporation is duly authorized to do so.

- 18. EXAMINATION OF PLANS, SPECIFICATIONS, AND SITE OF WORK:** The Contractor shall examine carefully the Project Site, the Plans and Specifications, other materials as described in the Special Provisions, Section 2-7, and the proposal forms. The signing of the Contract shall be conclusive evidence that the Contractor has investigated and is satisfied as to the conditions to be encountered, as to the character, quality, and scope of Work, the quantities of materials to be furnished, and as to the requirements of the Contract Documents.

- 19. CITY STANDARD PROVISIONS.** This contract is subject to the following standard provisions. See The WHITEBOOK for details.
 - 19.1.** The City of San Diego Resolution No. R-277952 adopted on May 20, 1991 for a Drug-Free Workplace.
 - 19.2.** The City of San Diego Resolution No. R-282153 adopted on June 14, 1993 related to the Americans with Disabilities Act.
 - 19.3.** The City of San Diego Municipal Code §22.3004 for Pledge of Compliance.
 - 19.4.** The City of San Diego's Labor Compliance Program and the State of California Labor Code §§1771.5(b) and 1776.
 - 19.5.** Sections 1777.5, 1777.6, and 1777.7 of the State of California Labor Code concerning the employment of apprentices by contractors and subcontractors performing public works contracts.
 - 19.6.** The City's Equal Benefits Ordinance (EBO), Chapter 2, Article 2, Division 43 of The San Diego Municipal Code (SDMC).
 - 19.7.** The City's Information Security Policy (ISP) as defined in the City's Administrative Regulation 90.63.

**AGREEMENT
FOR
CONSTRUCTION SERVICES
BETWEEN
THE CITY OF SAN DIEGO
AND
TC CONSTRUCTION COMPANY, INC.**

This sole-source construction services agreement (Agreement) is made and entered into by and between The City of San Diego (City), California a municipal corporation, and **TC CONSTRUCTION COMPANY, INC.** (Contractor), for the purpose of designing (when required) and constructing projects at the direction of the City Engineer. The City and the Contractor are referred to herein as the "Parties."

RECITALS

- A. The City desires to construct the project identified in Section 1, Description of Work.
- B. The City desires to contract with a single entity for Construction Services, as set forth in this agreement.
- C. The City has selected the Sole-Source Contractor to perform, either directly or with Subcontracts hereinafter defined, the design, engineering, and construction services set forth in this agreement and the Contract Documents.
- D. The Contractor is ready, willing, and able to perform the construction services required as specified in the Scope of Work and Services section of this agreement and in accordance with the terms and conditions of this agreement and under the direction of the Engineer.

In consideration of the above recitals and the mutual covenants and conditions set forth herein, and for good and valuable consideration, the receipt and sufficiency of which are hereby acknowledged, the Parties hereby set forth their mutual covenants and understandings as follows:

AGREEMENT

- A. The above referenced recitals are true and correct and are incorporated into this agreement by this reference.
- B. Exhibits referenced in this agreement are incorporated into the Agreement by this reference.
- C. This agreement incorporates the Standard Specifications for Public Works Construction (The 2015 GREENBOOK), including those amendments set forth in the City of San Diego Supplements included in The 2015 WHITEBOOK. All changes, additions, or both are stated herein and all other provisions remain unchanged.
- D. The Contractor shall comply with City's Equal Opportunity Contracting Program Requirements set forth in the Contract Documents. See The WHITEBOOK Part 10.
- E. The Contractor, including Subcontractors, not already having a City of San Diego Business Tax Certificate for the work contemplated shall secure the appropriate certificate from the City Treasurer, Civic Center Plaza, first floor, before the Agreement can be executed.

- F. Upon award, amendment, renewal, or extension of such contracts, the Contractors shall complete a Pledge of Compliance attesting under penalty of perjury that they complied with the requirements of City Municipal Code §22.3004.
- G. The Contractor shall ensure that the Subcontractors whose subcontracts are greater than \$50,000 in value complete a Pledge of Compliance attesting under penalty of perjury that they complied with the requirements of this section. The Contractor shall include in each subcontract agreement, language which requires Subcontractors to abide by the provisions of City Municipal Code §22.3004. A sample provision is as follows:
- “Subcontractor acknowledges that it is familiar with the requirements of San Diego Municipal Code §22.3004 (“Contractor Standards”), and agrees to comply with requirements of that section. The Subcontractor further agrees to complete the Pledge of Compliance, incorporated herein by reference.”
- H. Pledge of Compliance may be downloaded at:
- http://www.sandiego.gov/purchasing/pdf/contractor_standards_questionnaire.pdf
- I. The Contractor's attention is directed to the provisions of the State of California Labor Code §1776 (Stats. 1978, Ch. 1249). The Contractor shall be responsible for the compliance with these provisions by Subcontractors.
- J. The Contractor shall complete the work to be performed under this agreement and shall achieve Acceptance within the specified Working Days in the Notice Inviting Bids from the NTP unless authorized otherwise by the Engineer. Time is of essence for the completion of the Work and the Project has critical milestones to be met as listed in the Notice Inviting Bids.
- K. The City shall pay the Contractor for performance of the Work on a time and materials basis not to exceed \$100,000 without a written amendment to this Agreement.
- L. During the final design process (if any), if the Contractor modifies the Project such that a revision of the environmental document is required, the Contractor shall be responsible for all work required for implementing a revision, including preparation of revised documentation and coordination with City staff. Work shall not proceed on the project until the environmental requirements are met to the satisfaction of the City. There shall be no additional time allowed in the contract for processing and approval of revised permit documents.
- M. Prior to NTP or as required by the City, the Contractor shall:
- a) file surety bonds with the City to be approved by the City in the amounts and for the purposes noted in the Notice Inviting Bids and
 - b) obtain the required insurance in accordance with 7-3, “LIABILITY INSURANCE” and any additional insurance as may be specified in the Supplemental Special Provisions.

IN WITNESS WHEREOF, this Agreement is executed by the City of San Diego, acting by and through its Mayor or designee, pursuant to the contract provisions of City Charter §94 authorizing such execution, and by the Contractor.

THE CITY OF SAN DIEGO

APPROVED AS TO FORM

By Michelle Muñoz

Mara W. Elliot, City Attorney

By Jeremy Jung

Print Name: Michelle Muñoz
Contract Specialist
Public Works Department

Print Name: Jeremy Jung
Deputy City Attorney

Date: 1/4/17

Date: 1.4.17

CONTRACTOR

By Austin Cameron

Print Name: Austin Cameron

Title: PRESIDENT

Date: 12/20/16

City of San Diego License No.: BA87004773

State Contractor's License No.: 402459

AGREEMENT (continued)
PERFORMANCE BOND AND LABOR AND MATERIALMEN'S BOND

FAITHFUL PERFORMANCE BOND AND LABOR AND MATERIALMEN'S BOND:

TC Construction Company, Inc.; a corporation, as principal, and
Liberty Mutual Insurance Company, a corporation authorized to do
business in the State of California, as Surety, hereby obligate themselves, their successors and
assigns, jointly and severally, to The City of San Diego a municipal corporation in the sum of
One Hundred Thousand Dollars and Zero Cents (\$100,000.00) for the faithful performance of the
annexed contract, and in the sum of One Hundred Thousand Dollars and Zero Cents (\$100,000.00)
for the benefit of laborers and materialmen designated below.

Conditions:

If the Principal shall faithfully perform the annexed contract **Repairs at a Storm Drainage Pipe at 2582 Manzana Way**, Bid Number **K-17-6865-SLS-1**, San Diego, California then the obligation herein with respect to a faithful performance shall be void; otherwise it shall remain in full force.

If the Principal shall promptly pay all persons, firms and corporations furnishing materials for or performing labor in the execution of this contract, and shall pay all amounts due under the California Unemployment Insurance Act then the obligation herein with respect to laborers and materialmen shall be void; otherwise it shall remain in full force.

The obligation herein with respect to laborers and materialmen shall inure to the benefit of all persons, firms and corporations entitled to file claims under the provisions of Article 2, Claimants, (iii) public works of improvement commencing with Civil Code Section 9100 of the Civil Code of the State of California.

Changes in the terms of the annexed contract or specifications accompanying same or referred to therein shall not affect the Surety's obligation on this bond, and the Surety hereby waives notice of same.

AGREEMENT (continued)
PERFORMANCE BOND AND LABOR AND MATERIALMEN'S BOND

The Surety shall pay reasonable attorney's fees should suit be brought to enforce the provisions of this bond.

Dated December 20, 2016

Approved as to Form

TC Construction Company, Inc.

Principal

By 

Austin Cameron

Printed Name of Person Signing for Principal

Mara W. Elliot, City Attorney

By 

Deputy City Attorney

Liberty Mutual Insurance Company

Surety

By 

Minna Huovila Attorney-In-fact

Approved:

By: 

Michelle Muñoz
Contract Specialist
Public Works Department

790 The City Drive, Suite 200

Local Address of Surety

Orange, CA 92868

Local Address (City, State) of Surety

(714) 634-3311

Local Telephone No. of Surety

Premium \$ 1,026.00

Bond No. 024067668

CALIFORNIA ALL-PURPOSE ACKNOWLEDGMENT

CIVIL CODE § 1189

A notary public or other officer completing this certificate verifies only the identity of the individual who signed the document to which this certificate is attached, and not the truthfulness, accuracy, or validity of that document.

State of California
County of San Diego)

On December 20, 2016 before me, Diana Kai Murphy, Notary Public
(insert name and title of the officer)

personally appeared Minna Huovila
who proved to me on the basis of satisfactory evidence to be the person(s) whose name(s) is/are subscribed to the within instrument and acknowledged to me that he/she/they executed the same in his/her/their authorized capacity(ies), and that by his/her/their signature(s) on the instrument the person(s), or the entity upon behalf of which the person(s) acted, executed the instrument.

I certify under PENALTY OF PERJURY under the laws of the State of California that the foregoing paragraph is true and correct.

WITNESS my hand and official seal.

Signature

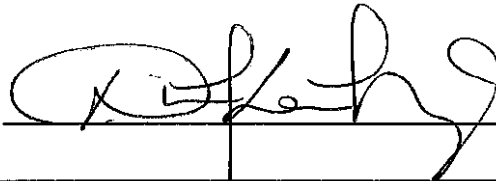

(Seal)



THIS POWER OF ATTORNEY IS NOT VALID UNLESS IT IS PRINTED ON RED BACKGROUND.

This Power of Attorney limits the acts of those named herein, and they have no authority to bind the Company except in the manner and to the extent herein stated.

Certificate No. 7552161

Liberty Mutual Insurance Company
The Ohio Casualty Insurance Company West American Insurance Company

POWER OF ATTORNEY

KNOWN ALL PERSONS BY THESE PRESENTS: That The Ohio Casualty Insurance Company is a corporation duly organized under the laws of the State of New Hampshire, that Liberty Mutual Insurance Company is a corporation duly organized under the laws of the State of Massachusetts, and West American Insurance Company is a corporation duly organized under the laws of the State of Indiana (herein collectively called the "Companies"), pursuant to and by authority herein set forth, does hereby name, constitute and appoint, Bradley R. Orr; Dale G. Harshaw; Geoffrey Shelton; John R. Qualin; Kyle King; Minna Huovila; Tara Bacon

all of the city of San Diego, state of CA each individually if there be more than one named, its true and lawful attorney-in-fact to make, execute, seal, acknowledge and deliver, for and on its behalf as surety and as its act and deed, any and all undertakings, bonds, recognizances and other surety obligations; in pursuance of these presents and shall be as binding upon the Companies as if they have been duly signed by the president and attested by the secretary of the Companies in their own proper persons.

IN WITNESS WHEREOF, this Power of Attorney has been subscribed by an authorized officer or official of the Companies and the corporate seals of the Companies have been affixed thereto this 22nd day of November, 2016.



The Ohio Casualty Insurance Company
Liberty Mutual Insurance Company
West American Insurance Company

By: David M. Carey
David M. Carey, Assistant Secretary

STATE OF PENNSYLVANIA ss
COUNTY OF MONTGOMERY

On this 22nd day of November, 2016, before me personally appeared David M. Carey, who acknowledged himself to be the Assistant Secretary of Liberty Mutual Insurance Company, The Ohio Casualty Company, and West American Insurance Company, and that he, as such, being authorized so to do, execute the foregoing instrument for the purposes therein contained by signing on behalf of the corporations by himself as a duly authorized officer.

IN WITNESS WHEREOF, I have hereunto subscribed my name and affixed my notarial seal at King of Prussia, Pennsylvania, on the day and year first above written.



COMMONWEALTH OF PENNSYLVANIA
Notarial Seal
Teresa Pastella, Notary Public
Upper Merion Twp., Montgomery County
My Commission Expires March 28, 2017
Member, Pennsylvania Association of Notaries

By: Teresa Pastella
Teresa Pastella, Notary Public

This Power of Attorney is made and executed pursuant to and by authority of the following By-laws and Authorizations of The Ohio Casualty Insurance Company, Liberty Mutual Insurance Company, and West American Insurance Company which resolutions are now in full force and effect reading as follows:

ARTICLE IV – OFFICERS – Section 12. Power of Attorney. Any officer or other official of the Corporation authorized for that purpose in writing by the Chairman or the President, and subject to such limitation as the Chairman or the President may prescribe, shall appoint such attorneys-in-fact, as may be necessary to act in behalf of the Corporation to make, execute, seal, acknowledge and deliver as surety any and all undertakings, bonds, recognizances and other surety obligations. Such attorneys-in-fact, subject to the limitations set forth in their respective powers of attorney, shall have full power to bind the Corporation by their signature and execution of any such instruments and to attach thereto the seal of the Corporation. When so executed, such instruments shall be as binding as if signed by the President and attested to by the Secretary. Any power or authority granted to any representative or attorney-in-fact under the provisions of this article may be revoked at any time by the Board, the Chairman, the President or by the officer or officers granting such power or authority.

ARTICLE XIII – Execution of Contracts – SECTION 5. Surety Bonds and Undertakings. Any officer of the Company authorized for that purpose in writing by the chairman or the president, and subject to such limitations as the chairman or the president may prescribe, shall appoint such attorneys-in-fact, as may be necessary to act in behalf of the Company to make, execute, seal, acknowledge and deliver as surety any and all undertakings, bonds, recognizances and other surety obligations. Such attorneys-in-fact subject to the limitations set forth in their respective powers of attorney, shall have full power to bind the Company by their signature and execution of any such instruments and to attach thereto the seal of the Company. When so executed such instruments shall be as binding as if signed by the president and attested by the secretary.

Certificate of Designation – The President of the Company, acting pursuant to the Bylaws of the Company, authorizes David M. Carey, Assistant Secretary to appoint such attorneys-in-fact as may be necessary to act on behalf of the Company to make, execute, seal, acknowledge and deliver as surety any and all undertakings, bonds, recognizances and other surety obligations.

Authorization – By unanimous consent of the Company's Board of Directors, the Company consents that facsimile or mechanically reproduced signature of any assistant secretary of the Company, wherever appearing upon a certified copy of any power of attorney issued by the Company in connection with surety bonds, shall be valid and binding upon the Company with the same force and effect as though manually affixed.

I, Renee C. Llewellyn, the undersigned, Assistant Secretary, The Ohio Casualty Insurance Company, Liberty Mutual Insurance Company, and West American Insurance Company do hereby certify that the original power of attorney of which the foregoing is a full, true and correct copy of the Power of Attorney executed by said Companies, is in full force and effect and has not been revoked.

IN TESTIMONY WHEREOF, I have hereunto set my hand and affixed the seals of said Companies this 20th day of December, 2016.



By: Renee C. Llewellyn
Renee C. Llewellyn, Assistant Secretary

Not valid for mortgage, note, loan, letter of credit, currency rate, interest rate or residual value guarantees.

To confirm the validity of this Power of Attorney call 1-610-832-8240 between 9:00 am and 4:30 pm EST on any business day.

EXHIBIT A

DRUG-FREE WORKPLACE CERTIFICATION

PROJECT TITLE: Repairs at a Storm Drainage Pipe at 2582 Manzana Way

I hereby certify that I am familiar with the requirements of San Diego City Council Policy No. 100-17 regarding Drug-Free Workplace as outlined in the WHITEBOOK, Section 7-13.3, "Drug-Free Workplace", of the project specifications, and that;

TC Construction Co., Inc

(Name under which business is conducted)

has in place a drug-free workplace program that complies with said policy. I further certify that each subcontract agreement for this project contains language which indicates the subcontractor's agreement to abide by the provisions of subdivisions a) through c) of the policy as outlined.

Signed

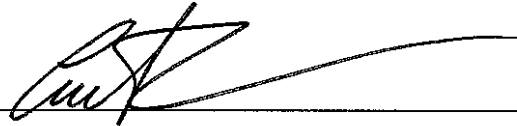

Printed Name

Austin Cameron

Title

PRESIDENT

EXHIBIT B

AMERICAN WITH DISABILITIES ACT (ADA) COMPLIANCE CERTIFICATION

EXHIBIT B

AMERICAN WITH DISABILITIES ACT (ADA) COMPLIANCE CERTIFICATION

PROJECT TITLE: Repairs at a Storm Drainage Pipe at 2582 Manzana Way

I hereby certify that I am familiar with the requirements of San Diego City Council Policy No. 100-4 regarding the American With Disabilities Act (ADA) outlined in the WHITEBOOK, Section 7-13.2, "American With Disabilities Act", of the project specifications, and that;

TC Construction Co. Inc

(Name under which business is conducted)

has in place workplace program that complies with said policy. I further certify that each subcontract agreement for this project contains language which indicates the subcontractor's agreement to abide by the provisions of the policy as outlined.

Signed _____

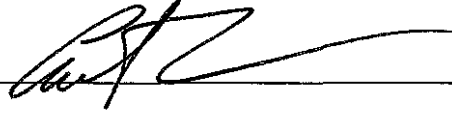

Printed Name _____

Austin Cameron

Title _____

PRESIDENT

EXHIBIT C

CONTRACTOR STANDARDS – PLEDGE OF COMPLIANCE

EXHIBIT C

CONTRACTOR STANDARDS - PLEDGE OF COMPLIANCE

PROJECT TITLE: Repairs at a Storm Drainage Pipe at 2582 Manzana Way

I declare under penalty of perjury that I am authorized to make this certification on behalf of TC Construction Co. Inc as Contractor, that I am familiar with the requirements of City of San Diego Municipal Code § 22.3004 regarding Contractor Standards as outlined in the WHITEBOOK, Section 7-13.4, "Contractor Standards", of the project specifications, and that Contractor has complied with those requirements.

I further certify that each of the Contractor's subcontractors whose subcontracts are greater than \$50,000 in value has completed a Pledge of Compliance attesting under penalty of perjury of having complied with City of San Diego Municipal Code § 22.3004.

Dated this 20th Day of December 2016.

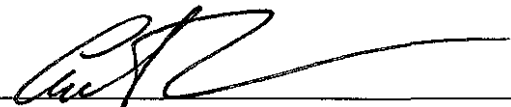
Signed 

Printed Name Austin Cameron

Title PRESIDENT

EXHIBIT D
AFFIDAVIT OF DISPOSAL

EXHIBIT D

AFFIDAVIT OF DISPOSAL

WHEREAS, on the _____ DAY OF _____, _____ the undersigned entered into and executed a contract with the City of San Diego, a municipal corporation, for:

(Name of Project or Task)

as particularly described in said contract and identified as Bid No. **K-17-6865-SLS-1**; SAP No. (WBS/IO/CC) **B-17079**; and **WHEREAS**, the specification of said contract requires the Contractor to affirm that "all brush, trash, debris, and surplus materials resulting from this project have been disposed of in a legal manner"; and **WHEREAS**, said contract has been completed and all surplus materials disposed of:

NOW, THEREFORE, in consideration of the final payment by the City of San Diego to said Contractor under the terms of said contract, the undersigned Contractor, does hereby affirm that all surplus materials as described in said contract have been disposed of at the following location(s):

and that they have been disposed of according to all applicable laws and regulations.

Dated this _____ DAY OF _____, _____.

Contractor
by

ATTEST:

State of _____
County of _____

On this _____ DAY OF _____, 2____, before the undersigned, a Notary Public in and for said County and State, duly commissioned and sworn, personally appeared _____ known to me to be the _____ Contractor named in the foregoing Release, and whose name is subscribed thereto, and acknowledged to me that said Contractor executed the said Release.

Notary Public in and for said County and State

EXHIBIT E

**NON-COLLUSION AFFIDAVIT TO BE EXECUTED BY BIDDER AND SUBMITTED WITH BID
UNDER 23 UNITED STATES CODE 112 AND PUBLIC CONTRACT CODE 7106**

EXHIBIT E

NON-COLLUSION AFFIDAVIT TO BE EXECUTED BY BIDDER AND SUBMITTED WITH BID UNDER 23 UNITED STATES CODE 112 AND PUBLIC CONTRACT CODE 7106

State of California)
County of SAN DIEGO) ss.

Austin Cameron, being first duly sworn, deposes and says that he or she is PRESIDENT of the party making the foregoing bid that the bid is not made in the interest of, or on behalf of, any undisclosed person, partnership, company, association, organization, or corporation; that the bid is genuine and not collusive or sham; that the bidder has not directly or indirectly induced or solicited any other bidder to put in a false or sham bid, and has not directly or indirectly colluded, conspired, connived, or agreed with any bidder or anyone else to put in a sham bid, or that anyone shall refrain from bidding; that the bidder has not in any manner, directly or indirectly, sought by agreement, communication, or conference with anyone to fix the bid price of the bidder or any other bidder, or to fix any overhead, profit, or cost element of the bid price, or of that of any other bidder, or to secure any advantage against the public body awarding the contract of anyone interested in the proposed contract; that all statements contained in the bid are true; and further, that the bidder has not, directly or indirectly, submitted his or her bid price or any breakdown thereof, or the contents thereof, or divulged information or data relative thereto, or paid, and will not pay, any fee to any corporation, partnership, company association, organization, bid depository, or to any member or agent thereof to effectuate a collusive or sham bid.

A notary public or other officer completing this certificate verifies only the identity of the individual who signed the document to which this certificate is attached, and not the truthfulness, accuracy, or validity of that document.

Signed: [Signature]

Title: PRESIDENT

Subscribed and sworn to before me this 20 day of DEC, 2016

T. PAPP

Notary Public

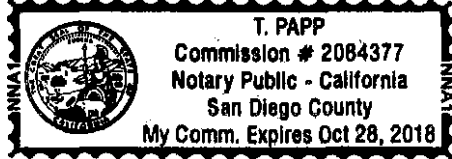

(SEAL)

EXHIBIT F

CONTRACTORS CERTIFICATION OF PENDING ACTIONS

I, the undersigned, being duly sworn, depose and say that the above is a true and correct copy of the original as the same appears in the files of the County of Santa Clara, California, and that the same is a true and correct copy of the original as the same appears in the files of the County of Santa Clara, California, and that the same is a true and correct copy of the original as the same appears in the files of the County of Santa Clara, California.

1974
Commission # 000000
Notary Public
San Jose, California
My Comm. Expires 01/01/2017



EXHIBIT F

CONTRACTORS CERTIFICATION OF PENDING ACTIONS

As part of its bid or proposal (Non-Price Proposal in the case of Design-Build contracts), the Bidder shall provide to the City a list of all instances within the past ten years where a complaint was filed or pending against the Bidder in a legal or administrative proceeding alleging that Bidder discriminated against its employees, subcontractors, vendors or suppliers, and a description of the status or resolution of that complaint, including any remedial action taken.

CHECK ONE BOX ONLY.

- The undersigned certifies that within the past 10 years the Bidder has NOT been the subject of a complaint or pending action in a legal administrative proceeding alleging that Bidder discriminated against its employees, subcontractors, vendors or suppliers.

- The undersigned certifies that within the past 10 years the Bidder has been the subject of a complaint or pending action in a legal administrative proceeding alleging that Bidder discriminated against its employees, subcontractors, vendors or suppliers. A description of the status or resolution of that complaint, including any remedial action taken and the applicable dates is as follows:

DATE OF CLAIM	LOCATION	DESCRIPTION OF CLAIM	LITIGATION (Y/N)	STATUS	RESOLUTION/REMEDIAL ACTION TAKEN

Contractor Name: TC Construction Co. Inc

Certified By Austin Cameron Title PRESIDENT
Name

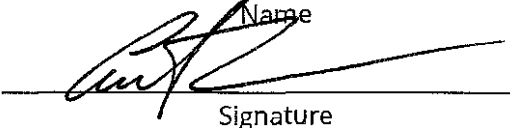
 Date 12/20/16
Signature

USE ADDITIONAL FORMS AS NECESSARY

EXHIBIT G

EQUAL BENEFITS ORDINANCE CERTIFICATION OF COMPLIANCE

EXHIBIT G

EQUAL BENEFITS ORDINANCE CERTIFICATION

I declare under penalty of perjury that I am familiar with the requirements of and in compliance with the City of San Diego Municipal Code § 22.4300 regarding Equal Benefits Ordinance.

EXHIBIT H

FORMS

LIST OF SUBCONTRACTORS

In accordance with the requirements of the "Subletting and Subcontracting Fair Practices Act", Section 4100, of the California Public Contract Code (PCC), the Bidder is to list below the name, address and license number of each Subcontractor who will perform work, labor, render services or specially fabricate and install a portion [type] of the work or improvement, in an amount of or in excess of 0.5% of the Contractor's total Bid. Failure to comply with this requirement may result in the Bid being rejected as non-responsive. The Contractor is to list only one Subcontractor for each portion of the Work. The Bidder's attention is directed to the Special Provisions - General; Paragraph 2-3 Subcontracts, which stipulates the percentage of the Work to be performed with the Bidder's own forces. The Bidder is to also list all SLBE, ELBE, DBE, DVBE, MBE, WBE, OBE, SDB, WoSB, HUBZone, and SDVOSB Subcontractors for which the Bidders are seeking recognition towards achieving any mandatory, voluntary, or both subcontracting participation percentages.

NAME, ADDRESS AND TELEPHONE NUMBER OF SUBCONTRACTOR	CONSTRUCTOR OR DESIGNER	SUBCONTRACTOR LICENSE NUMBER	TYPE OF WORK	DOLLAR VALUE OF SUBCONTRACT	MBE, WBE, DBE, DVBE, OBE, ELBE, SLBE, SDB, WoSB, HUBZone, OR SDVOSB	WHERE CERTIFIED	CHECK IF JOINT VENTURE PARTNERSHIP
Name: <u>NONE</u> Address: _____ City: _____ State: _____ Zip: _____ Phone: _____ Email: _____	S						
Name: _____ Address: _____ City: _____ State: _____ Zip: _____ Phone: _____ Email: _____							

⓪ As appropriate, Bidder shall identify Subcontractor as one of the following and shall include a valid proof of certification (except for OBE, SLBE and ELBE):

- | | | | |
|---|--------|--|---------|
| Certified Minority Business Enterprise | MBE | Certified Woman Business Enterprise | WBE |
| Certified Disadvantaged Business Enterprise | DBE | Certified Disabled Veteran Business Enterprise | DVBE |
| Other Business Enterprise | OBE | Certified Emerging Local Business Enterprise | ELBE |
| Certified Small Local Business Enterprise | SLBE | Small Disadvantaged Business | SDB |
| Woman-Owned Small Business | WoSB | HUBZone Business | HUBZone |
| Service-Disabled Veteran Owned Small Business | SDVOSB | | |

⓪ As appropriate, Bidder shall indicate if Subcontractor is certified by:

- | | | | |
|--|------|--|----------|
| City of San Diego | CITY | State of California Department of Transportation | CALTRANS |
| California Public Utilities Commission | CPUC | State of California's Department of General Services | CADoGS |
| City of Los Angeles | LA | State of California | CA |
| U.S. Small Business Administration | SBA | | |

The Bidder will not receive any subcontracting participation percentages if the Bidder fails to submit the required proof of certification.

NAMED EQUIPMENT/MATERIAL SUPPLIER LIST

The Bidder seeking the recognition of equipment, materials, or supplies obtained from Suppliers towards achieving any mandatory, voluntary, or both subcontracting participation percentages is to list the Supplier(s) on the Named Equipment/Material Supplier List. The Named Equipment/Material Supplier List, at a minimum, is to have the name, locations (City) and the **DOLLAR VALUE** of the Suppliers. The Bidder will be credited up to 60% of the amount to be paid to the Suppliers for such materials and supplies unless vendor manufactures or substantially alters materials and supplies in which case 100% will be credited. The Bidder is to indicate (Yes/No) whether listed firm is a supplier or manufacturer. In calculating the subcontractor participation percentages, vendors/suppliers will receive 60% credit of the listed **DOLLAR VALUE**, whereas manufacturers will receive 100% credit. If no indication provided, listed firm will be credited at 60% of the listed dollar value for purposes of calculating the Subcontractor Participation Percentage, Suppliers will receive 60% credit of the listed **DOLLAR VALUE**, whereas manufacturers will receive 100% credit. If no indication provided, listed firm will be credited at 60% of the listed **DOLLAR VALUE** for purposes of calculating the subcontractor participation percentages.

NAME, ADDRESS AND TELEPHONE NUMBER OF VENDOR/SUPPLIER	MATERIALS OR SUPPLIES	DOLLAR VALUE OF MATERIAL OR SUPPLIES (MUST BE FILLED OUT)	SUPPLIER (Yes/No)	MANUFACTURER (Yes/No)	MBE, WBE, DBE, DVBE, OBE, ELBE, SLBE, SDB, WoSB, HUBZone, OR SDVOSB®	WHERE CERTIFIED®
Name: <u>NONE</u> Address: _____ City: _____ State: _____ Zip: _____ Phone: _____ Email: _____						
Name: _____ Address: _____ City: _____ State: _____ Zip: _____ Phone: _____ Email: _____						

ⓐ As appropriate, Bidder shall identify Vendor/Supplier as one of the following and shall include a valid proof of certification (except for OBE,SLBE and ELBE):

- | | | | |
|---|--------|--|---------|
| Certified Minority Business Enterprise | MBE | Certified Woman Business Enterprise | WBE |
| Certified Disadvantaged Business Enterprise | DBE | Certified Disabled Veteran Business Enterprise | DVBE |
| Other Business Enterprise | OBE | Certified Emerging Local Business Enterprise | ELBE |
| Certified Small Local Business Enterprise | SLBE | Small Disadvantaged Business | SDB |
| Woman-Owned Small Business | WoSB | HUBZone Business | HUBZone |
| Service-Disabled Veteran Owned Small Business | SDVOSB | | |

ⓑ As appropriate, Bidder shall indicate if Vendor/Supplier is certified by:

- | | | | |
|--|------|--|----------|
| City of San Diego | CITY | State of California Department of Transportation | CALTRANS |
| California Public Utilities Commission | CPUC | State of California's Department of General Services | CADoGS |
| City of Los Angeles | LA | State of California | CA |
| U.S. Small Business Administration | SBA | | |

The Bidder will not receive any subcontracting participation percentages if the Bidder fails to submit the required proof of certification.

EXHIBIT I

SUPPLEMENTARY SPECIAL PROVISIONS (SSP)

SUPPLEMENTARY SPECIAL PROVISIONS

The following Supplementary Special Provisions (SSP) modifies the following documents:

- 1) The **2015 Edition** of the Standard Specifications for Public Works Construction (The "GREENBOOK").
 - 2) The **2015 Edition** of the City of San Diego Standard Specifications for Public Works Construction (The "WHITEBOOK"), addressed as the "City Supplement" herein, including the following:
 1. General Provisions (A) for all Contracts.
-

SECTION 1 - TERMS, DEFINITIONS, ABBREVIATIONS, UNITS OF MEASURE, AND SYMBOLS

- 1-2 TERMS AND DEFINITIONS.** To the City Supplement, item 54, "Normal Working Hours", ADD the following:

The **Normal Working Hours** are 8:30 AM to 3:30 PM.

SECTION 2 - SCOPE AND CONTROL OF WORK

- 2-3.2 Self Performance.** DELETE in its entirety and SUBSTITUTE with the following:

1. You shall perform, with your own organization, Contract Work amounting to at least 50% of the base Bid.

- 2-16 CONTRACTOR REGISTRATION AND ELECTRONIC REPORTING SYSTEM.** To the City Supplement, item 1, DELETE in its entirety.

SECTION 4 - CONTROL OF MATERIALS

- 4-1.6 Trade Names or Equals.** To the City Supplement, ADD the following:

11. You shall submit your list of proposed substitutions for an "equal" item **no later than 5 Working Days after the determination of the Apparent Low Bidder** and on the City's Product Submittal Form available at:

<http://www.sandiego.gov/publicworks/edocref/index.shtml>

SECTION 5 – UTILITIES

5-2 PROTECTION. To the City Supplement, item 2, ADD the following:

- g) Refer to Appendix "O" for more information on the protection of AMI devices.

SECTION 6 – PROSECUTION, PROGRESS AND ACCEPTANCE OF WORK

ADD:

6-3.2.1.1 Environmental Document.

1. The City of San Diego Public Works Department has prepared a Notice of Exemption for Repairs at a Storm Drainage Pipe at 2582 Manzana Way (Storm drain pipe repair at 2582 Manzana Way), as referenced in the Contract Exhibit. You shall comply with all requirements of the NOE as set forth in Exhibit L.
2. Compliance with the City's environmental document shall be included in the Contract Price.

6-8.3 Warranty. To the City Supplement, item 1, DELETE in its entirety and SUBSTITUTE with the following:

1. Warranty and repair all defective materials and workmanship for a period of 1 year. This call back warranty period shall start on the date that the Work was accepted by the City. Additionally, you shall warranty the Work against all latent and patent defects for a period of 10 years.

SECTION 7 - RESPONSIBILITIES OF THE CONTRACTOR

7-3 INSURANCE. DELETE in its entirety and SUBSTITUTE with the following:

7-3 INSURANCE.

1. The insurance provisions herein shall not be construed to limit your indemnity obligations contained in the Contract.

7-3.1 Policies and Procedures.

1. You shall procure the insurance described below, at its sole cost and expense, to provide coverage against claims for loss including injuries to persons or damage to property, which may arise out of or in connection with the performance of the Work by you, your agents, representatives, officers, employees or Subcontractors.
2. Insurance coverage for property damage resulting from your operations is on a replacement cost valuation. The market value will not be accepted.

3. You shall maintain this insurance for the duration of this Contract and at all times thereafter when you are correcting, removing, or replacing Work in accordance with this Contract. Your liabilities under the Contract, e.g., your indemnity obligations, is not deemed limited to the insurance coverage required by this Contract.
4. The payment for insurance shall be included in the Contract Price as bid by you. Except as specifically agreed to by the City in writing, you are not entitled to any additional payment. Do not begin any Work under this Contract until you have provided and the City has approved all required insurance.
5. Policies of insurance shall provide that the City is entitled to 30 Days (10 Days for cancellation due to non-payment of premium) prior written notice of cancellation or non-renewal of the policy. Maintenance of specified insurance coverage is a material element of the Contract. Your failure to maintain or renew coverage or to provide evidence of renewal during the term of the Contract may be treated by the City as a material breach of the Contract.

7-3.2 Types of Insurance.

7-3.2.1 Commercial General Liability Insurance.

1. Commercial General Liability Insurance shall be written on the current version of the ISO Occurrence form CG 00 01 07 98 or an equivalent form providing coverage at least as broad.
2. The policy shall cover liability arising from premises and operations, XCU (explosions, underground, and collapse), independent contractors, products/completed operations, personal injury and advertising injury, bodily injury, property damage, and liability assumed under an insured's contract (including the tort liability of another assumed in a business contract).
3. There shall be no endorsement or modification limiting the scope of coverage for either "insured vs. insured" claims or contractual liability. You shall maintain the same or equivalent insurance for at least 10 years following completion of the Work.
4. All costs of defense shall be outside the policy limits. Policy coverage shall be in liability limits of not less than the following:

<u>General Annual Aggregate Limit</u>	<u>Limits of Liability</u>
Other than Products/Completed Operations	\$2,000,000
Products/Completed Operations Aggregate Limit	\$2,000,000
Personal Injury Limit	\$1,000,000
Each Occurrence	\$1,000,000

7-3.2.2 Commercial Automobile Liability Insurance.

1. You shall provide a policy or policies of Commercial Automobile Liability Insurance written on the current version of the ISO form CA 00 01 12 90 or later version or equivalent form providing coverage at least as broad in the amount of \$1,000,000 combined single limit per accident, covering bodily injury and property damage for owned, non-owned, and hired automobiles ("Any Auto").
2. All costs of defense shall be outside the limits of the policy.

7-3.3 Rating Requirements. Except for the State Compensation Insurance Fund, all insurance required by this Contract as described herein shall be carried only by responsible insurance companies with a rating of, or equivalent to, at least "A-, VI" by A.M. Best Company, that are authorized by the California Insurance Commissioner to do business in the State, and that have been approved by the City.

7-3.3.1 Non-Admitted Carriers. The City will accept insurance provided by non-admitted, "surplus lines" carriers only if the carrier is authorized to do business in the State and is included on the List of Approved Surplus Lines Insurers (LASLI list).

All policies of insurance carried by non-admitted carriers shall be subject to all of the requirements for policies of insurance provided by admitted carriers described herein.

7-3.4 Evidence of Insurance. Furnish to the City documents e.g., certificates of insurance and endorsements evidencing the insurance required herein, and furnish renewal documentation prior to expiration of this insurance. Each required document shall be signed by the insurer or a person authorized by the insurer to bind coverage on its behalf. We reserve the right to require complete, certified copies of all insurance policies required herein.

7-3.5 Policy Endorsements.

7-3.5.1 Commercial General Liability Insurance.

7-3.5.1.1 Additional Insured.

1. You shall provide at your expense policy endorsement written on the current version of the ISO Occurrence form CG 20 10 11 85 or an equivalent form providing coverage at least as broad.
2. To the fullest extent allowed by law e.g., California Insurance Code §11580.04, the policy shall be endorsed to include the City and its respective elected officials, officers, employees, agents, and representatives as additional insured.
3. The additional insured coverage for projects for which the Engineer's Estimate is \$1,000,000 or more shall include liability arising out of:

- a) Ongoing operations performed by you or on your behalf,
 - b) your products,
 - c) your Work, e.g., your completed operations performed by you or on your behalf, or
 - d) premises owned, leased, controlled, or used by you.
4. The additional insured coverage for projects for which the Engineer's Estimate is less than \$1,000,000 shall include liability arising out of:
- a) Ongoing operations performed by you or on your behalf,
 - b) your products, or
 - c) premises owned, leased, controlled, or used by you.

7-3.5.1.2 Primary and Non-Contributory Coverage. The policy shall be endorsed to provide that the coverage with respect to operations, including the completed operations, if appropriate, of the Named Insured is primary to any insurance or self-insurance of the City and its elected officials, officers, employees, agents and representatives. Further, it shall provide that any insurance maintained by the City and its elected officials, officers, employees, agents and representatives shall be in excess of your insurance and shall not contribute to it.

7-3.5.1.3 Project General Aggregate Limit. The policy or policies shall be endorsed to provide a Designated Construction Project General Aggregate Limit that will apply only to the Work. Only claims payments which arise from the Work shall reduce the Designated Construction Project General Aggregate Limit. The Designated Construction Project General Aggregate Limit shall be in addition to the aggregate limit provided for the products-completed operations hazard.

7-3.5.2 Commercial Automobile Liability Insurance.

7-3.5.2.1 Additional Insured. Unless the policy or policies of Commercial Auto Liability Insurance are written on an ISO form CA 00 01 12 90 or a later version of this form or equivalent form providing coverage at least as broad, the policy shall be endorsed to include the City and its respective elected officials, officers, employees, agents, and representatives as additional insured, with respect to liability arising out of automobiles owned, leased, hired or borrowed by you or on your behalf. This endorsement is limited to the obligations permitted by California Insurance Code §11580.04.

7-3.6 Deductibles and Self-Insured Retentions. You shall pay for all deductibles and self-insured retentions. You shall disclose deductibles and self-insured retentions to the City at the time the evidence of insurance is provided.

7-3.7 Reservation of Rights. The City reserves the right, from time to time, to review your insurance coverage, limits, deductibles and self-insured retentions to determine if they are acceptable to the City. The City will reimburse you, without overhead, profit, or any other markup, for the cost of additional premium for any coverage requested by the Engineer but not required by this Contract.

7-3.8 Notice of Changes to Insurance. You shall notify the City 30 Days prior to any material change to the policies of insurance provided under this Contract.

7-3.9 Excess Insurance. Policies providing excess coverage shall follow the form of the primary policy or policies e.g., all endorsements.

7-4 NOT USED. DELETE in its entirety and SUBSTITUTE with the following:

7-4 WORKERS' COMPENSATION INSURANCE AND EMPLOYERS LIABILITY INSURANCE.

1. In accordance with the provisions of §3700 of the California Labor Code, you shall provide at your expense Workers' Compensation Insurance and Employers Liability Insurance to protect you against all claims under applicable state workers compensation laws. The City, its elected officials, and employees will not be responsible for any claims in law or equity occasioned by your failure to comply with the requirements of this section.

2. Limits for this insurance shall be not less than the following:

<u>Workers' Compensation</u>	<u>Statutory Employers Liability</u>
Bodily Injury by Accident	\$1,000,000 each accident
Bodily Injury by Disease	\$1,000,000 each employee
Bodily Injury by Disease	\$1,000,000 policy limit

3. By signing and returning the Contract you certify that you are aware of the provisions of §3700 of the Labor Code which requires every employer to be insured against liability for worker's compensation or to undertake self-insurance in accordance with the provisions of that code and you shall comply with such provisions before commencing the Work as required by §1861 of the California Labor Code.

7-4.1. Waiver of Subrogation. The policy or policies shall be endorsed to provide that the insurer will waive all rights of subrogation against the City and its respective elected officials, officers, employees, agents, and representatives for losses paid under the terms of the policy or policies and which arise from Work performed by the Named Insured for the City.

7-8.6 Water Pollution Control. To the City Supplement, ADD the following:

6. Based on a preliminary assessment by the City, this Contract is subject to WPCP.

7-20 ELECTRONIC COMMUNICATION. To the City Supplement, ADD the following:

2. Virtual Project Manager shall be used on this Contract.

7-21.1 General. To the City Supplement, item 3, DELETE in its entirety and SUBSTITUTE with the following:

3. During the construction phase of projects, the minimum waste management reduction goal is 90% of the inert material (a material not subject to decomposition such as concrete, asphalt, brick, rock, block, dirt, metal, glass, and etc.) and 65% of the remaining project waste. You shall provide appropriate documentation, including a Waste Management Form attached as an appendix, and evidence of recycling and reuse of materials to meet the waste reduction goals specified.

SECTION 9 - MEASUREMENT AND PAYMENT

**ADD
9-3.7**

Compensation Adjustments for Price Index Fluctuations. To the City Supplement ADD the following:

5. This Contract is not subject to the provisions of The "WHITEBOOK" for Compensation Adjustments for Price Index Fluctuations for paving asphalt.

SECTION 217 - BEDDING AND BACKFILL MATERIALS

217-2.2 **Stones, Boulders, and Broken Concrete.** To Table 217-2.2, DELETE in its entirety and SUBSTITUTE with the following:

TABLE 217-2.2

Zone	Zone Limits	Maximum Size (greatest dimension)	Backfill Requirements in Addition to 217-2.1
Street or Surface Zone	From ground surface to 12" (300 mm) below pavement subgrade or ground surface	2.5" (63 mm)	As required by the Plans or Special Provisions.
Street or Surface Zone Backfill of Tunnels beneath Concrete Flatwork		Sand	Sand equivalent of not less than 30.
Trench Zone	From 12" (300 mm) below pavement subgrade or ground surface to 12" (300 mm) above top of pipe or box	6" (150 mm)	
Deep Trench Zone (Trenches 3' (0.9 m) wide or wider)	From 60" (1.5 m) below finished surface to 12" (300 mm) above top of pipe or box	Rocks up to 12" (300 mm) excavated from trench may be placed as backfill	
Pipe Zone	From 12" (300 mm) above top of pipe or box to 6" (150 mm) below bottom of pipe or box exterior	2.5" (63 mm)	Sand equivalent of not less than 30 or a coefficient of permeability greater than 1-½ inches/hour (35 mm per hour).

Overexcavation	Backfill more than 6" (150 mm) below bottom of pipe or box exterior	6" (150 mm)	Sand equivalent of not less than 30 or a coefficient of permeability greater than 1-½ inches/hour (35 mm per hour). Trench backfill slurry (100-E-100) per 201-1 may also be used.
----------------	---	-------------	--

SECTION 304 -METAL FABRICATION AND CONSTRUCTION

304-5 PAYMENT. To the City Supplement, REVISE section "304-5" to "304-6".

EQUAL OPPORTUNITY CONTRACTING PROGRAM (EOCP) SECTION A – GENERAL REQUIREMENTS

4.1 NONDISCRIMINATION IN CONTRACTING ORDINANCE. To the City Supplement, subsection 4.1.1, paragraph (2), sentence (1), DELETE in its entirety and SUBSTITUTE with the following:

You shall not discriminate on the basis of race, gender, gender expression, gender identity, religion, national origin, ethnicity, sexual orientation, age, or disability in the solicitation, selection, hiring, or treatment of subcontractors, vendors, or suppliers.

END OF SUPPLEMENTARY SPECIAL PROVISIONS (SSP)

EXHIBIT J
PROPOSAL

EXHIBIT J

PROPOSAL

To the City of San Diego:

In accordance with the Contractors proposal, the specifications and requirements on file with the City Clerk and the Contract documents, and subject to all provisions of the Charter and Ordinances of the City of San Diego and applicable laws and regulations of the United States and the State of California, the undersigned hereby proposes to furnish to the City of San Diego, complete at the prices stated herein, the items or services hereinafter mentioned. The undersigned further warrants that this bid is not made in the interest of, or on behalf of, any undisclosed person, partnership, company, association, organization, or corporation; that the bid is genuine and not collusive or sham; that the bidder has not directly or indirectly induced or solicited any other bidder to put in a false or sham bid, and has not directly or indirectly colluded, conspired, connived, or agreed with any bidder or anyone else to put in a sham bid, or that anyone shall refrain from bidding; that the bidder has not in any manner, directly or indirectly, sought by agreement, communication, or conference with anyone to fix the bid price of the bidder or any other bidder, or to fix any overhead, profit, or cost element of the bid price, or of that of any other bidder, or to secure any advantage against the public body awarding the contract of anyone interested in the proposed contract; that all statements contained in the bid are true; and, further, that the bidder has not, directly or indirectly, submitted his or her bid price or any breakdown thereof, or the contents thereof, or divulged information or data relative thereto, or paid, and will not pay, any fee to any corporation, partnership, company, association, organization, bid depository, or to any member or agent thereof to effectuate a collusive or sham bid.

The undersigned bidder(s) further warrants that bidder(s) has thoroughly examined and understands the entire Contract Documents (plans and specifications) and the Bidding Documents therefore, and that by submitting said Bidding Documents as its bid proposal, bidder(s) acknowledges and is bound by the entire Contract Documents, including any addenda issued thereto, as such Contract Documents incorporated by reference in the Bidding Documents.

IF A SOLE OWNER OR SOLE CONTRACTOR SIGN HERE:

- (1) Name under which business is conducted _____
- (2) Signature (Given and surname) of proprietor _____
- (3) Place of Business (Street & Number) _____
- (4) City and State _____ Zip Code _____
- (5) Telephone No. _____ Facsimile No. _____

IF A PARTNERSHIP, SIGN HERE:

- (1) Name under which business is conducted _____

(2) Name of each member of partnership, indicate character of each partner, general or special (limited):

(3) Signature (Note: Signature must be made by a general partner)

Full Name and Character of partner

(4) Place of Business (Street & Number) _____

(5) City and State _____ Zip Code _____

(6) Telephone No. _____ Facsimile No. _____

IF A CORPORATION, SIGN HERE:

(1) Name under which business is conducted _____

(2) Signature, with official title of officer authorized to sign for the corporation:



(Signature)

Austin Cameron

(Printed Name)

PRESIDENT

(Title of Officer)

(Impress Corporate Seal Here)

(3) Incorporated under the laws of the State of California

(4) Place of Business (Street & Number) 10540 PROSPECT AVE

(5) City and State Santee CA Zip Code 92071

(6) Telephone No. 619 448-4560 Facsimile No. 619 258-9761

THE FOLLOWING SECTIONS MUST BE FILLED IN BY ALL PROPOSERS:

In accordance with the "GENERAL", the bidder holds a California State Contractor's license for the following classification(s) to perform the work described in these specifications:

LICENSE CLASSIFICATION A, C-21

LICENSE NO. 402459 EXPIRES 4/30/17

DEPARTMENT OF INDUSTRIAL RELATIONS (DIR) REGISTRATION NUMBER: 1000003132

This license classification must also be shown on the front of the bid envelope. Failure to show license classification on the bid envelope may cause return of the bid unopened.

TAX IDENTIFICATION NUMBER (TIN): [REDACTED]

E-Mail Address: acameron@tcincsd.com

THIS PROPOSAL MUST BE NOTARIZED BELOW:

I certify, under penalty of perjury, that the representations made herein regarding my State Contractor's license number, classification and expiration date are true and correct.

Signature [Signature] Title PRESIDENT

SUBSCRIBED AND SWORN TO BEFORE ME, THIS 20 DAY OF December, 2016

Notary Public in and for the County of San Diego, State of CA

T. Papp
(NOTARIAL SEAL)

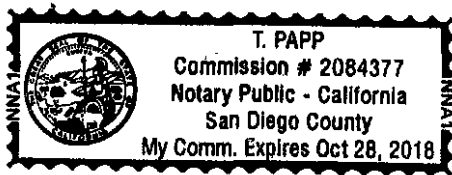

A notary public or other officer completing this certificate verifies only the identity of the individual who signed the document to which this certificate is attached, and not the truthfulness, accuracy, or validity of that document.

EXHIBIT K

CONTRACTOR'S COMPENSATION RATE SCHEDULE

UNITED STATES OF AMERICA
COUNTY OF LOS ANGELES
CITY OF LOS ANGELES
DEPARTMENT OF PUBLIC WORKS
STREET LIGHTS DIVISION
2016

QUAN I
REPAIRS & MAINTENANCE
CONTRACTOR'S COMPENSATION RATE SCHEDULE
2016

EXHIBIT K

CONTRACTOR'S COMPENSATION RATE SCHEDULE

The following Compensation Rate Schedule shall constitute the maximum rates (e.g., labor, direct costs, etc.) for Extra Work, if any, provided by the Contractor during the term of this agreement.

These rates are being specified as the Contractor's standard established rates for calculating labor costs without allowance for overhead and profits. For markup provisions and allowable charges refer to 3-2.4, "Agreed Prices."

T&M RATES



7/1/2015

EQUIP #	EQUIP DESCRIPTION	MODEL	SIZE	BUCKET SIZE / PAYLOAD	HOURLY BARE RENTAL	OPERATED RATE
EXCAVATORS						
MINI EXCAVATORS						
2236	MINI GEHL	GE-502	10,934	18"-24"	60.00	141.00
2339	KOMATSU MINI	PC-60	14,991	18"-36"	70.00	151.00
3091	CATERPILLAR	308ECR SB	18,300	18"-36"	70.00	151.00
3114	CATERPILLAR	308E 2	18,500	18"-36"	70.00	151.00
SMALL EXCAVATORS (UNDER 47,000 LBS)						
1873	CATERPILLAR	312B	27,410	18"-55"	80.00	161.00
2013	CATERPILLAR	313B CR	29,540	18"-55"	80.00	161.00
1818	CATERPILLAR	PC 150-6	39,500	18"-55"	90.00	171.00
2132	KOMATSU	PC 200	43,000	24"-67"	95.00	176.00
2133	KOMATSU	PC 200	43,000	24"-67"	95.00	176.00
2201	KOBELCO W/BLADE	ED190	43,700	18"-55"	105.00	186.00
2253	KOBELCO W/BLADE	ED 190	43,700	18"-55"	105.00	186.00
2178	LINKBELT	210 LX	44,800	18"-55"	95.00	176.00
2197	LINKBELT	210 LX	44,800	18"-55"	95.00	176.00
2198	LINKBELT	210 LX	44,800	18"-55"	95.00	176.00
1968	CATERPILLAR	320CL	46,300	24"-67"	100.00	181.00
1990	CATERPILLAR	320CL	46,300	24"-67"	100.00	181.00
2249	CATERPILLAR	320CL	46,300	24"-67"	100.00	181.00
MEDIUM EXCAVATORS (50,000-99,000 LBS)						
2027	LINKBELT	240LX	52,700	24"-67"	125.00	206.00
3070	CATERPILLAR	320 ELRR	56,440	27"-68"	125.00	206.00
3113	CATERPILLAR	320 ELRR	56,440	27"-68"	125.00	206.00
2090	CATERPILLAR	330C	77,400	27"-68"	145.00	226.00
2015	LINKBELT	330LX	78,000	27"-68"	145.00	226.00
2016	LINKBELT	330LX	78,000	27"-68"	145.00	226.00
2179	LINKBELT	330 LX	78,000	27"-68"	145.00	226.00
2247	LINKBELT	330LX	78,000	27"-68"	145.00	226.00
3074	CATERPILLAR	336E	82,000	27"-68"	145.00	226.00
1884	KOMATSU	PC 400	94,000	27"-68"	165.00	246.00
2211	KOMATSU	PC400LC-6	94,000	27"-68"	165.00	246.00
1848	CATERPILLAR	345B	95,000	27"-76"	165.00	246.00
LARGE EXCAVATORS (100,000-150,000 LBS)						
2154	LINKBELT	460LX	101,200	27"-76"	175.00	256.00
2131	KOMATSU	PC 600	140,000	27"-76"	260.00	341.00
EX LARGE EXCAVATORS (OVER 150,000 LBS)						
2155	LINKBELT	800LX	174,600	32"-78"	300.00	381.00

EQUIP #	EQUIP DESCRIPTION	MODEL	SIZE	BUCKET SIZE / PAYLOAD	HOURLY BARE RENTAL	OPERATED RATE
EXCAVATOR ATTACHMENTS						
	COMPACTION WHEELS	312B-320C	18"-36"		20.00	
	COMPACTION WHEELS	330C-460LX	24'-48"		20.00	
	COMPACTION WHEELS	375-800LX	24"-48"		20.00	
	ADDITIONAL BUCKETS	312B-320C	18"-48"		20.00	
	ADDITIONAL BUCKETS	330C-460LX	24"-60"		20.00	
	ADDITIONAL BUCKETS	375-800LX	32"-78"		20.00	
	THUMB ATTACHMENT	312B-320C			10.00	
	THUMB ATTACHMENT	330C-460LX			10.00	
BREAKERS / DEMOLITION						
3040	4,500 LB BREAKER FITS PC-200, 320C	TB980	4,500lb		72.00	
2172	2,000 LB BREAKER FITS 313B, ED190	TB725	2,000lb		50.00	
2173	2,000 LB BREAKER FITS ED190, 313B	TB725	2,000lb		50.00	
2258	13,500 LB BREAKER FITS 345B, 350, 460LX	TB2580	13,500lb		144.00	
2284	13,500 LB BREAKER FITS 345B,350, 460LX	TB5300	13,500lb		144.00	
1942	PULVERIZER / PROCESSOR LABOUNTY	CP100	345B/350		62.00	
2395	HYDRAULIC MULTI PROCESSOR CAT MP30	MP 30	345B/350		110.00	
BACKHOE LOADERS						
420 BACKHOE						
2246	CATERPILLAR	420D	15,700	12"-36"	62.00	143.00
2075	CATERPILLAR	420D	15,800	12"-36"	62.00	143.00
2076	CATERPILLAR	420D	15,800	12"-36"	62.00	143.00
2077	CATERPILLAR	420D	15,800	12"-36"	62.00	143.00
2078	CATERPILLAR	420D	15,800	12"-36"	62.00	143.00
3109	CATERPILLAR	420F	15,200	12"-36"	62.00	143.00
3110	CATERPILLAR	420F	15,200	12"-36"	62.00	143.00
3111	CATERPILLAR	420F	15,200	12"-36"	62.00	143.00
3112	CATERPILLAR	420F	15,200	12"-36"	62.00	143.00
446 BACKHOE						
1913	CATERPILLAR	446B	19,600	18"-48"	75.00	156.00
1919	CATERPILLAR	446B	19,600	18"-48"	75.00	156.00
1920	CATERPILLAR	446B	19,600	18"-48"	75.00	156.00
1921	CATERPILLAR	446B	19,600	18"-48"	75.00	156.00
2182	CATERPILLAR	446D	19,600	18"-48"	75.00	156.00
2183	CATERPILLAR	446D	19,600	18"-48"	75.00	156.00
2195	CATERPILLAR	446D	19,600	18"-48"	75.00	156.00
2196	CATERPILLAR	446D	19,600	18"-48"	75.00	156.00
BACKHOE ATTACHMENTS & BREAKERS						
2260	750 BREAKER FITS 420D		750LB		25.00	
2168	1,100 BREAKER FITS 420D	TB425	1,100lb		28.00	
2109	1,100 BREAKER FITS 420D	TB425	1,100lb		28.00	
2172	2,000 BREAKER FITS 446D	TB725	2,000lb		43.00	
2173	2,000 BREAKER FITS 446D	TB725	2,000lb		43.00	
	HYDRAULIC AUGER	420D	6"-24"		12.50	
	FORKS	420D	60"		5.00	

EQUIP #	EQUIP DESCRIPTION	MODEL	SIZE	BUCKET SIZE / PAYLOAD	HOURLY BARE RENTAL	OPERATED RATE
	FORKS	446B/D	60"		5.00	
	EXTRA BUCKETS	420D	12"-36"		5.00	
	EXRTA BUCKETS	446B/D	18"-48"		5.00	
	COMPACTION WHEEL	420/446	18"-24"		20.00	
WHEEL LOADERS						
SMALL LOADERS						
1997	CATERPILLAR	928G	27,250	2.9yd	90.00	171.00
MEDIUM LOADER						
1849	CATERPILLAR	938G	29,700	3.5yd	95.00	176.00
1886	CATERPILLAR	938G	29,700	3.5yd	95.00	176.00
1969	CATERPILLAR	938G	29,700	3.5yd	95.00	178.00
2014	KAWASAKI	70ZIV	33,000	3.2yd	95.00	176.00
2026	KAWASAKI	70ZIV	33,000	3.2yd	95.00	176.00
2159	KAWASAKI	70ZIV	33,000	3.2yd	95.00	176.00
2160	KAWASAKI	70ZIV	33,000	3.2yd	95.00	176.00
2180	KAWASAKI	70ZV	34,000	3.2yd	95.00	176.00
2199	KAWASAKI	70ZV	34,000	3.2yd	95.00	176.00
2200	KAWASAKI	70ZV	34,000	3.2yd	95.00	176.00
2251	KAWASAKI	70ZV	34,000	3.2yd	95.00	176.00
3064	CATERPILLAR	938K	35000	3.2yd	95.00	176.00
LARGE LOADERS						
1962	KAWASAKI	80Z	39,825	4yd	110.00	191.00
2158	KAWASAKI	80ZIV	39,825	4yd	110.00	191.00
2181	KAWASAKI	80ZV	39,825	4yd	110.00	191.00
2248	KAWASAKI	80ZV	39,825	4yd	110.00	191.00
1885	CATERPILLAR	950G	40,435	4yd	110.00	191.00
EX LARGE LOADERS						
2139	KAWASAKI	95ZV	66,330	7yd	200.00	281.00
WHEEL LOADER ATTACHMENTS						
	FORKS				10.00	
	BOOM LIFTS / SNORKLE				10.00	
	SIDE DUMP BUCKET				10.00	
	SKELETON BUCKET				10.00	
	4 IN 1 MULTIPURPOSE				15.00	
	PICK UP BROOM			10'	20.00	
TRACK LOADERS						
2202	CATERPILLAR	963C	44,500	3.5yd	135.00	216.00
TRACK DOZERS						
3075	DOZER CATERPILLAR	D6T	56,158	6-WAY	150.00	231.00
	SLOPE BOARD				10.00	
COMPACT TRACK LOADERS						
3115	CATERPILLAR	299D XHP rubr	11,612	.75 / 6-WAY	90.00	171.00
3116	CATERPILLAR	299D XHP steel	12,000	.75 / 6-WAY	90.00	171.00
SKIPLOADER/SKIDSTERS						
2380	BOBCAT	S150	5,935	.4yd	45.00	126.00
2092	CATERPILLAR SKID	248	7,800	.5yd	54.00	135.00

EQUIP #	EQUIP DESCRIPTION	MODEL	SIZE	BUCKET SIZE / PAYLOAD	HOURLY BARE RENTAL	OPERATED RATE
2101	CATERPILLAR SKID	248	7,800	.5yd	54.00	135.00
2223	CATERPILLAR SKID	248B	7,800	.5yd	54.00	135.00
2224	CATERPILLAR SKID	248B	7,800	.5yd	54.00	135.00
2354	CATERPILLAR SKID	248	7,800	.5yd	54.00	135.00
3030	CATERPILLAR SKID	272C	8,362	.6yd	65.00	146.00
3031	CATERPILLAR SKID	272C	8,362	.6yd	65.00	146.00
2229	JOHN DEERE SKIP LOADER	210LE	14,500	1yd	31.00	112.00
2270	JOHN DEERE SKIP LOADER	210LE	14,500	1yd	31.00	112.00
SKIDSTEER ATTACHMENTS						
2348	SWEEPSTER BROOM	SB60		60"	19.00	
2099	SWEEPSTER BROOM	SB72		72"	19.00	
2102	SWEEPSTER BROOM	SB72		72"	19.00	
2103	SWEEPSTER BROOM	SB72		72"	19.00	
2106	SWEEPSTER BROOM	SB72		72"	19.00	
3037	500LB BREAKER	TOP35		500LB	18.50	
2351	1,000LB BREAKER	304		1,000LB	25.00	
2108	1,100LB BREAKER	TB425		1,100LB	28.00	
2109	1,100LB BREAKER	TB425		1,100LB	28.00	
3023	HYDRAULIC AUGER	HA20HB		6"-24"	12.50	
2105	BACKHOE ATTACHMENT CAT	H30			19.00	
3032	COLD PLANER CAT	PC206		24"	50.00	
2404	COLD PLANER CAT	PC9		24"	50.00	
2100	COLD PLANER CAT	AP760		24"	50.00	
	PALLET FORKS	CAT		48"	6.00	
	MULTIPURPOSE BUCKET CAT	4 IN 1		72"	9.00	
2104	GRAPPLE BUCKET	CAT		72"	9.00	
	TRENCHER LOWE	40C			9.50	
	MOWER CAT	BR272		72"	11.50	
GRADERS						
3063	CATERPILLAR	140M	43,950	14'	120.00	201.00
CRANE						
1980	LINKBELT ROUGH TERRAIN BOOM EXTENSION	RT8060	60 Ton		218.00 50.00	299.00
2171	DROTT CRANE	85RM2	4 Ton		24.00	105.00
PAVERS						
2336	BLAW-KN	DM5500		6'-10'	95.00	176.00
2177	PAVER INGERSOLL	PF3120	15,800	8'-15'	149.00	230.00
2406	PAVER CAT AP-1055D	AP-1055D	44,780	10'-18'	272.00	353.00
ROLLERS						
3060	CATERPILLAR ROLLER	CB14	2,415	33"	24.00	105.00
3117	CATERPILLAR UTILITY COMPACTOR	CB24B	6,003	47"	35.00	116.00
3118	WACKER ROLLER / walk behind	RD7H	1,829	25.5"	24.00	105.00
2275	BOMAG ROLLER	BW120AD	5,952	48"	35.00	116.00
2332	BOMAG ROLLER	BW120AD	5,952	48"	35.00	116.00
2353	SAKAI ROLLER	SW320	7,055	48"	35.00	116.00
2241	IR SMOOTH ROLLER COMPACTOR	SD77FB	16,350	66"	43.00	124.00
2242	INGERSOLL PADFOOT ROLLER	SD77FB	16,350	66"	43.00	124.00

EQUIP #	EQUIP DESCRIPTION	MODEL	SIZE	BUCKET SIZE / PAYLOAD	HOURLY BARE RENTAL	OPERATED RATE
2343	BOMAG ROLLER	BW141AD-2	15,414	59"	38.00	119.00
2119	IR SMOOTH ROLLER COMPACTOR	SD70FB	15,330	66"	43.00	124.00
2210	INGERSOL RAND	DD90	21,404	66"	47.00	128.00
3035	CATERPILLAR ROLLER	CB54	23,818	66"	47.00	128.00
3061	CATERPILLAR ROLLER	CD54B	23,525	66"	47.00	128.00
3085	CATERPILLAR 9 WHEEL RUBBER	CW14	28,500	68"	45.00	126.00
COMPACTION EQUIPMENT						
2151	VIBRATE PLATE MIKASA	MVH-200	450	19.7"	21.00	102.00
2152	VIBRATE PLATE MIKASA	MVH-200	450	19.7"	21.00	102.00
1874	VIBRATE PLATE MIKASA	MVH-502	1,202	27.6"	24.00	105.00
2126	VIBRATE PLATE MULTIQUIP	MVH-502	1,202	27.6"	21.00	102.00
2164	VIBRATE PLATE MULTIQUIP	MVH-502	1,202	27.6"	24.00	105.00
2207	VIBRATE PLATE MULTIQUIP	MVH-502	1,202	27.6"	24.00	105.00
2221	MULTIQUIP RAMMAX walk/beh	P33/24FC	2,998	33"	40.00	121.00
2222	MULTIQUIP RAMMAX walk/beh WACKER/TAMPER	P33/24FC MT74F	2,998	33"	40.00 19.00	121.00 100.00
CRUSHING PLANT EQUIPMENT						
1580	PORTABLE SCREEN EXTEC	5000S	31,500	40" X 33'		
1998	BELT CONVEYOR FLECO 320	CD	7,200	4yd Hopper		
2360	METSO NORDBERG SCREEN	ST620	60,720	3 decks 19'8"x5'11"		
2361	METSO NORDBERG CONE	LT300HP	95,000	9 cu yard		
2362	METSO NORDBERG JAW	LT105	90,400	8-12 cu yard		
2387	SUPERIOR RADIAL STACKER	PRSC-S	15,400	30" X 60'		
2386	MEGGA BAGGER	MBT-2	3,700	2-1yd Hoppers		
FORKLIFTS/SCISSOR LIFT						
3102	TELEHANDLER CAT	TH255	13,000	5500 lift	54.00	135.00
2219	TELEHANDLER JLG	G9-43A	25,907	9000 lift	64.00	145.00
2220	TELEHANDLER JLG	G6-42A	20,400	6000 lift	54.00	135.00
2239	TELEHANDLER JLG	G6-42A	20,400	6000 lift	54.00	135.00
1785	FORKLIFT CAT	AM30	47,760	30,000 lift	70.00	151.00
1786	FORKLIFT CAT	V300B	42,280	30,000 lift	56.00	137.00
ARROW/MESSAGE BOARDS						
1509	ARROWBOARD-SOLAR	WANCO			18.00	
1788	ARROWBOARD-SOLAR	AMIDA			18.00	
1789	ARROWBOARD-SOLAR	AMIDA			18.00	
1800	ARROWBOARD-SOLAR	WANCO			18.00	
1801	ARROWBOARD-SOLAR	WANCO			18.00	
2390	MESSAGE BOARD WVT3	WVT3			20.00	
2995	MESSAGE-SOLAR PREC	PRECISION			20.00	
2998	MESSAGE-SOLAR PREC	PRECISION			20.00	
2999	MESSAGE-SOLAR PREC	PRECISION			20.00	
3006	ARROWBOARD-SOLAR	ECLIPSE			18.00	
3007	ARROWBOARD-SOLAR	ALAMOND			18.00	
3008	ARROWBOARD-SOLAR	ALAMOND			18.00	
3009	ARROWBOARD-SOLAR	ALAMOND			18.00	
3039	ARROWBOARD-SOLAR	SOLAR TECH			18.00	
3099	ARROWBOARD-SOLAR	FLATIRON			18.00	

EQUIP #	EQUIP DESCRIPTION	MODEL	SIZE	BUCKET SIZE / PAYLOAD	HOURLY BARE RENTAL	OPERATED RATE
3100	ARROWBOARD-SOLAR	FLATIRON			18.00	
3101	ARROWBOARD-SOLAR	FLATIRON			18.00	
TRAFFIC CONTROL / DAILY						
	BARRICADES				1.50	
	BARRICADES W/Signs				3.00	
	BARRICADES W/Signs and Lighted				4.00	
	SOFT SIGN BARRICADES				19.00	
	NO PARK BARRICADES				1.00	
	DELINEATORS				1.00	
	CONES				1.00	
	STOP/SLOW PADELS				8.00	
STEEL PLATES						
	1" X 4' X 4'				0.32	
	1" X 4' X 8'				0.38	
	1" X 4' X 10'				0.44	
	1" X 5' X 5'				0.31	
	1" X 5' X 10'				0.44	
	1" X 8' X 10'				0.75	
	1" X 8' X 15'				0.96	
	1" X 8' X 20'				1.44	
	1 1/2" X 8' X 20'				2.25	
	1 1/2" X 8' X 30'				3.13	
	1 1/2" X 10' X 30'				3.75	
SHIELDS						
	8' X 8' Manhole boxes				7.50	
	10' X 10' Manhole boxes				8.75	
	4' X 14' Shield				3.75	
	4' X 20' Shield				5.00	
	4' X 24' Shield				7.50	
	4' X 28' Shield				10.00	
	6' X 14' Shield				4.60	
	6' X 20' Shield				6.25	
	6' X 24' Shield				8.75	
	6' X 28' Shield				11.25	
	8' X 14' Shield				6.25	
	8' X 20' Shield				10.00	
	8' X 24' Shield				12.50	
	8' X 28' Shield				15.00	
	8' X 30' Shield				17.50	
	8' X 32' Shield				21.25	
	10' X 14' Shield				7.50	
	10' X 20' Shield				12.50	
	10' X 24' Shield				15.00	
	10' X 28' Shield				21.25	
	10' X 30' Shield				25.00	
	10' X 32' Shield				27.50	
	12' X 14' Shield				10.00	

EQUIP #	EQUIP DESCRIPTION	MODEL	SIZE	BUCKET SIZE / PAYLOAD	HOURLY BARE RENTAL	OPERATED RATE
	12' X 20' Shield				15.00	
	12' X 24' Shield				20.00	
	12' X 28' Shield				25.00	
	12' X 30' Shield				27.50	
	12' X 32' Shield				30.00	
	K-RAIL					
	10'				0.65	
	20'				0.85	
	GENERATORS					
3065	GENERATOR ONAN	1250	12.5KW		25.00	
3083	GENERATOR POWERPRO	25	25KW		32.00	
3046	GENERATOR IR G40	G40	30KW		38.00	
3047	GENERATOR IR G40	G40	30KW		38.00	
1861	GENERATOR COLEMAN	Q-PAC	50KW		43.00	
3029	GENERATOR HOUSE GENERAC	SD080	80KW		55.00	
	PUMPS PORTABLE/TOWABLE					
2233	4" GODWIN	CD103M	900gpm		40.00	
2234	4" GODWIN	CD103M	900gpm		40.00	
2137	4" GORMAN RUPP	14A2-TS2	600gpm		35.00	
2194	12" GODWIN	CD300M	6000gpm		105.00	
2213	4" MULTIQUIP	QP40TH	400gpm		15.00	
2214	4" MULTIQUIP	QP40TH	400gpm		15.00	
2215	4" MULTIQUIP	QP40TH	400gpm		15.00	
2012	6" GODWIN	HL5M	1450gpm		50.00	
1987	8" CASE	6591TA	2300gpm		60.00	
	2" ELECTRIC SUBMERSIBLE PUMPS / 110v		62gpm		4.50	
	3" TRASH PUMP PORTABLE / Honda engine		85gpm		12.00	
	2" ELECTRIC SUBMERSIBLE PUMPS/220		90gpm		5.00	
	3" ELECTRIC SUBMERSIBLE PUMPS		120gpm		8.50	
	3" CENTRIFICAL PUMP PORTABLE / Honda		270gpm		12.00	
	4" ELECTRIC SUBMERSIBLE PUMPS		500gpm		14.00	
	EXTRA SUCTION HOSE 25'		3"-6"		5.00	
	EXTRA SUCTION HOSE 25'		8"-12"		8.00	
	EXTRA DISCHARGE HOSE 50'		3"-6"		5.00	
	EXTRA DISCHARGE HOSE 50'		8"-12"		8.00	
	FIRE HOSE 50'		1 1/2"		3.00	
	FIRE HOSE 50'		2 1/2"		4.00	
	HYDROSTATIC TEST PUMP		5-11gpm		10.50	
	50' POWER CORD				3.00	
	TEMPORARY POWER BOX				3.00	
	LIGHT TOWERS					
3025	LIGHT TOWER IR	LSC-80HZ	4.5kw		20.00	
3026	LIGHT TOWER IR	LSC-60HZ	4.5kw		20.00	
3048	LIGHT TOWER IR/DOOSAN	LSC-60HZ	4.5kw		26.00	
3049	LIGHT TOWER IR/DOOSAN	LSC-60HZ	4.5kw		26.00	
2997	PORTABLE LIGHT TOWER TEREX		6kw		20.00	
	AIR COMPRESSORS / AIR TOOLS					

EQUIP #	EQUIP DESCRIPTION	MODEL	SIZE	BUCKET SIZE / PAYLOAD	HOURLY BARE RENTAL	OPERATED RATE
2043	COMPRESSOR-TOWING 185CFM	185cfm			44.00	
2113	COMPRESSOR-TOWING 185CFM	185cfm			44.00	
2115	COMPRESSOR-TOWING 185CFM	185cfm			44.00	
2120	COMPRESSOR-TOWING 185CFM	185cfm			44.00	
2278	COMPRESSOR AIRM PDS185S	185cfm			44.00	
3020	TOWABLE COMPRESSOR IR	185cfm			44.00	
3021	TOWABLE COMPRESSOR IR	185cfm			44.00	
	AIR JACK HAMMERS/POWDER PUFF 30/60/90				4.50	
	CHIPPING GUNS				3.50	
	ELECTRIC HAMMER 60LB				10.00	
MISCELLANEOUS						
801	CEMENT MIXER				12.00	
1415	CEMENT MIXER				12.00	
1426	CEMENT MIXER				12.00	
1689	SHEEPSFOOT 5 X 5				18.00	
1709	LEAK FINDER				12.00	
1762	CHLORINATION TRAILER				13.50	
1783	MOBILE OFFICE 12 X 60				12.00	
1973	GRINDER REMAX TOW BEHIND	4800		36"-48"	254.00	
2004	LEAK FINDER				12.00	
2982	CHLORINATION TRAILER				13.50	
3016	MITY MITE BLOWER / TRAILER	12,000cfm	20"		8.00	
3017	TREBOR MADE BLOWER / TRAILER	10,000cfm	18"		8.00	
ASPHALT / CONCRETE EQUIPMENT						
2328	CURB MACHINE POWER CURB BERM	MILLER			50.00	131.00
2357	STRIPING MACHINE LINE LASER 3900	3900			25.00	
3027	ZIEMAN TRAILER SEAL TANK	w/1000		1000GAL	25.00	
3033	LEE BOY TACK WAGON	573B		150GAL	50.00	
	CONCRETE VIBRATOR w/stinger	110V			5.00	
	CONCRETE VIBRATOR w/stinger HI-CYCLE	HI-CYC			9.75	
FLAT SAWS & SAW TRUCKS						
2060	MECO FLAT SAW 60HP	M-60			45.00	
2276	TRUCK FORD F550XLT	F550		18000	50.00	131.00
2300	TRUCK FORD	F450		15000	50.00	131.00
3036	HUSQVARNA FLAT SAW 46HP	IS4600			45.00	
3086	HUSQVARNA FLAT SAW 61HP	FS 6100 D			45.00	
3066	DIAMOND 4 SPEED DRILL	DR401			40.00	
3119	DIAMOND 4 SPEED DRILL	DR401			40.00	
	PARTNER/STIHL 12/14" CHOP SAW	650/750			8.50	
SWEEPERS						
2165	SWEEPER SCHW M600OTE	26,380	26,000		133.00	193.00
WATER TRUCKS / TOWER						
1732	WATER TRUCK	FORD	35,000	2000GAL	50.00	110.00
2163	WATER TRUCK	INTERNAT	35,000	2500GAL	50.00	110.00
1534	WATER TRUCK	AUTO CAR	54,000	4000GAL	60.00	120.00
1567	WATER TRUCK	FORD	54,000	4000GAL	60.00	120.00

EQUIP #	EQUIP DESCRIPTION	MODEL	SIZE	BUCKET SIZE / PAYLOAD	HOURLY BARE RENTAL	OPERATED RATE
1902	WATER TRUCK	FORD	54,000	4000GAL	60.00	120.00
1655	WATER TRUCK	INTERNAT	54,000	5000GAL	70.00	130.00
2313	500 WATER BUFFALO	MILLER	TRAILER	500GAL	14.00	
3024	500 WATER BUFFALO	DEMCO	TRAILER	500GAL	14.00	
3034	500 WATER BUFFALO	EXP500	TRAILER	500GAL	14.00	
1984	WATER TOWER	GLENDALE	TRAILER	12,000GAL	17.00	
SEMI TRUCK W/TRAILER						
1768	TRUCK PETE ROLL OFF	19,800	80,000		95.00	155.00
2020	TRUCK PETE (SEE TRAILERS BELOW)	20,660	80,000			
3050	TRUCK PETE 367 (SEE TRAILERS BELOW)	20,800	80,000			
3051	TRUCK PETE 367 (SEE TRAILERS BELOW)	20,800	80,000			
3104	TRUCK PETE 367 (SEE TRAILERS BELOW)	20,800	80,000			
2264	TRUCK WESTERN STAR 4900SA (SEE TRAILERS BELOW)	22,000	80,000			
1575	TRL LOWBED SIEBERT 5-AXLE	19,960	110,000		125.00	185.00
1692	TRL LOWBED SIEBERT JEEP 7-AXLE	16,620	120,000		140.00	200.00
2271	TRL LOWBED MURRAY 5-AXLE	19,450	110,000		125.00	185.00
2272	TRL LOWBED MURRAY JEEP 7-AXLE	17,530	120,000		140.00	200.00
2403	TRL TRAIL KING BEAVER TAIL	20,280	70,000		110.00	170.00
END DUMPS W/TRUCK						
1665	1992 WESTERN MODEL END DUMP	17,400	80,000		100.00	160.00
1737	END DUMP REL TRACTOR/TRL	18,800	80,000		100.00	160.00
1985	END DUMP HIGH SIDE WESTERN	20,000	80,000		110.00	170.00
2396	END DUMP HIGH SIDE WESTERN	20,000	80,000		110.00	170.00
SIDE DUMPS W/TRUCK						
2393	SIDE DUMP TRAILERS THURSTON	15,520	80,000	44,400	110.00	170.00
2394	SIDE DUMP TRAILERS THURSTON	15,520	80,000	44,400	110.00	170.00
BOOSTER TRUCKS						
2079	BOOSTER TRK PETE 357 SUPERDUMP	24,400	66,000		100.00	160.00
2080	BOOSTER TRK PETE 357 SUPERDUMP	24,400	66,000		100.00	160.00
2116	BOOSTER TRK PETE 330 SUPERDUMP	26,000	66,000		100.00	160.00
2141	BOOSTER TRK PETE 379 SUPERDUMP	25,800	66,000		100.00	160.00
2142	BOOSTER TRK PETE 379 SUPERDUMP	25,750	66,000		100.00	160.00
2143	BOOSTER TRK PETE 379 SUPERDUMP	25,750	66,000		100.00	160.00
2144	BOOSTER TRK PETE 379 SUPERDUMP	25,850	66,000		100.00	160.00
2145	BOOSTER TRK PETE 379 SUPERDUMP	25,800	66,000		100.00	160.00
2203	BOOSTER TRK WEST 4900FA	24,900	66,000		100.00	160.00
TRUCK AND TRANSFERS						
1822	TRUCK & TRANSFER PETE	29,040	80,000	50,960	95.00	155.00
1879	TRUCK & TRANSFER PETE	29,040	80,000	50,960	95.00	155.00
1892	TRUCK & TRANSFER INT	30,780	80,000	49,220	95.00	155.00
1931	TRUCK & TRANSFER INT	30,780	80,000	49,220	95.00	155.00
1938	TRUCK & TRANSFER PETE	30,800	80,000	49,200	95.00	155.00
1940	TRUCK & TRANSFER PETE	30,800	80,000	49,200	95.00	155.00
3052	TRUCK & TRANSFER PETE 384	30,380	80,000	49,620	95.00	155.00
3055	TRUCK & TRANSFER PETE 384	30,180	80,000	49,820	95.00	155.00
3057	TRUCK & TRANSFER PETE 384	30180	80,000	49820	95.00	155.00

EQUIP #	EQUIP DESCRIPTION	MODEL	SIZE	BUCKET SIZE / PAYLOAD	HOURLY BARE RENTAL	OPERATED RATE
TEN WHEELERS / MISC						
BOBTAIL DUMP TRUCK						
1901	BOBTAIL FORD 6 YARD DUMP	FORD	35,000		95.00	155.00
3054	BOBTAIL PETE 6 YARD DUMP	337 PETE	33,000		95.00	155.00
3108	TACK DUMP TRUCK PETE 567	30180	80,000	49820	95.00	155.00
SUPERINTENDENT TRUCKS						
2175	TRK CHEV QUAD 4WD	2500HD	9,200		44.00	
2176	TRK CHEV QUAD 4WD	2500HD	9,200		44.00	
2216	TRK CHEV QUAD 4WD	2500HD	9,200		44.00	
2217	TRK CHEV QUAD 4WD	2500HD	9,200		44.00	
2218	TRK CHEV QUAD 4WD	2500HD	9,200		44.00	
2237	FORD TRK SUPERDUTY SAFETY	F250	9,200		44.00	
2238	FORD TRK SUPERDUTY	F350	11,000		44.00	
2295	TRK CHEVY SILVERADO	2500HD	9,200		44.00	
2296	TRK CHEVY SILVERADO	2500HD	9,200		44.00	
3076	TRK GMC SIERRA	C1500	5,058		44.00	
2299	TRK CHEVY SILVERADO	2500HD	9,200		44.00	
ESTIMATING VEHICLES						
2073	TRK DODGE QUAD CAB / PARTS RUNNER	DAKOTA	4,172		44.00	
2074	TRK DODGE QUAD CAB	DAKOTA	4,172		44.00	
3105	GMC YUKON XL	GMC	5,820		44.00	
2407	FORD FOCUS	FOCUS	2,960		35.00	
3092	CHEVY CRUZE	CHEVROLET	3,084		35.00	
3093	CHEVY CRUZE	CHEVROLET	3,084		35.00	
3094	CHEVY CRUZE	CHEVROLET	3,084		35.00	
3095	CHEVY CRUZE	CHEVROLET	3,084		35.00	
3096	CHEVY CRUZE	CHEVROLET	3,084		35.00	
3097	CHEVY CRUZE	CHEVROLET	3,084		35.00	
FOREMANS TRUCKS						
1995	FOREMAN TRK CHEV UTILITY	3500	15,000		44.00	
2124	FOREMAN TRK FORD UTILITY	F450	15,000		44.00	
2123	FOREMAN TRK FORD UTILITY	F450	15,000		44.00	
2127	FOREMAN TRK FORD UTILITY	F450	15,000		44.00	
2128	FOREMAN TRK FORD UTILITY	F450	15,000		44.00	
2146	FOREMAN TRK FORD UTILITY	F450	15,000		44.00	
2147	FOREMAN TRK FORD UTILITY	F450	15,000		44.00	
2148	FOREMAN TRK FORD UTILITY	F450	15,000		44.00	
2149	FOREMAN TRK FORD UTILITY	F450	15,000		44.00	
2150	FOREMAN TRK FORD UTILITY	F450	15,000		44.00	
2184	FOREMAN TRK FORD UTILITY	F450	15,000		44.00	
2185	FOREMAN TRK FORD UTILITY	F450	15,000		44.00	
2186	FOREMAN TRK FORD UTILITY	F450	15,000		44.00	
2187	FOREMAN TRK FORD UTILITY	F450	15,000		44.00	
2188	FOREMAN TRK FORD UTILITY	F450	15,000		44.00	
2189	FOREMAN TRK FORD UTILITY	F450	15,000		44.00	
2190	FOREMAN TRK FORD UTILITY	F450	15,000		44.00	

EQUIP #	EQUIP DESCRIPTION	MODEL	SIZE	BUCKET SIZE / PAYLOAD	HOURLY BARE RENTAL	OPERATED RATE
2191	FOREMAN TRK FORD UTILITY	F450	15,000		44.00	
2192	FOREMAN TRK FORD UTILITY	F450	15,000		44.00	
2193	FOREMAN TRK FORD UTILITY	F450	15,000		44.00	
2310	FOREMAN TRK FORD UTILITY	F250	4,872		44.00	
3041	FOREMAN TRK DODGE UTILITY	4500	26,000		44.00	
3042	FOREMAN TRK DODGE UTILITY	4500	26,000		44.00	
3043	FOREMAN TRK DODGE UTILITY	4500	26,000		44.00	
3044	FOREMAN TRK DODGE UTILITY	4500	26,000		44.00	
3045	FOREMAN TRK DODGE UTILITY	4500	26,000		44.00	
3077	FOREMAN TRK DODGE UTILITY	4500	26,000		44.00	
3078	FOREMAN TRK DODGE UTILITY	4500	26,000		44.00	
3079	FOREMAN TRK DODGE UTILITY	4500	26,000		44.00	
3080	FOREMAN TRK DODGE UTILITY	4500	26,000		44.00	
3081	FOREMAN TRK DODGE UTILITY	4500	26,000		44.00	
3082	FOREMAN TRK DODGE UTILITY	4500	26,000		44.00	
BOXBUILDER TRUCK						
2225	BOXBUILDER TRK FORD	F450	15,000		40.00	
2122	BOXBUILDER TRK FORD	F450	15,000		40.00	
1943	BOXBUILDER TRK FORD	F450	15,000		40.00	
1944	BOXBUILDER TRK FORD	F450	15,000		40.00	
2147	BOXBUILDER TRK FORD	F450	15,000		40.00	
2315	BOXBUILDER TRK FORD	F450	15,000		40.00	
JOBSITE TRUCK W / MIXER						
1856	TRUCK FLATBED W/MIXER	F450	15,000		15.00	
1899	TRUCK FLATBED W/MIXER	F450	15,000		15.00	
CONE / SIGN TRUCKS						
1948	CONE/SIGN TRK	DODGE 3500	15,000		40.00	
2038	CONE/SIGN TRK	DODGE 3500	15,000		40.00	
MAINTENANCE / WELDER TRUCKS						
1900	TRUCK-WELDER FORD	F450	15,000		77.00	158.00
2257	FUEL TRUCK PETE	PETE 357	70,000		161.00	242.00
2305	WELDER TRUCK FORD	F550	18,000		77.00	158.00
2993	WELDER TRUCK FORD	F350	15,000		77.00	158.00
3107	TRUCK-MECHANIC	337 PETE	33,000		90.00	171.00
COMPRESSOR TRUCK W/DUMP						
1724	COMPRESSOR DUMP TRK GMC	185CFM	26,000		90.00	150.00
1725	COMPRESSOR DUMP TRK GMC	185CFM	26,000		90.00	150.00
1726	COMPRESSOR DUMP TRK GMC	185CFM	26,000		90.00	150.00
1727	COMPRESSOR DUMP TRK GMC	185CFM	26,000		90.00	150.00
TRAILERS						
712	JOBSITE TRAILER 8' X 23'		70		12.00	
1635	JOBSITE TRAILER CC-20961		5553		12.00	
1991	FLATBED TRAILER UTIL FLATBED		1588		12.00	
2000	JOB SITE TRAILER BROW VAN		10860		12.00	
2009	JOB SITE TRAILER MILL VAN		10860		12.00	
2069	JOB TRAILER		5000		12.00	

EQUIP #	EQUIP DESCRIPTION	MODEL	SIZE	BUCKET SIZE / PAYLOAD	HOURLY BARE RENTAL	OPERATED RATE
2070	JOB TRAILER #2		3000		12.00	
2071	JOB TRAILER #3		5000		12.00	
2096	JOB CLEAN UP TRAILER HOME		2530		12.00	
2256	TRAILER T2K5 UTIL		550		18.00	
2311	TRAILER 27" VAN		10860		12.00	
2325	TRAILER NEAL FB		1500		10.00	
2326	TRAILER ZEMA		1800		10.00	
2331	TRAILER ZEMA		7,500		10.00	
2337	TRAILING TK20 20		20,000		18.00	
2346	TRAILER ZEMA		10,000		10.00	
2383	TRAILER AROS		7,500		10.00	
3010	JOBSITE TRAILER CONNEX		10,000		12.00	
3011	JOBSITE TRAILER CONNEX		10,000		12.00	
3012	JOBSITE TRAILER		20,000		12.00	
3013	JOBSITE TRAILER		20,000		12.00	
3014	BIG TEX TRAILER		10,000		10.00	
3062	ZIEMAN TRAILER		20,000		12.00	

LABOR

SUPERINTENDANT W/TRUCK	147.00
SUPERINTENDANT W/O TRUCK	103.00
FOREMAN W/TRUCK	138.00
FOREMAN W/O TRUCK	94.00
CARPENTER W/TRUCK	108.00
CARPENTER W/O TRUCK	68.00
MECHANIC/WELDER W/TRUCK	158.00
MECHANIC/WELDER W/O TRUCK	81.00
OPERATOR	81.00
OILER	78.00
LEADMAN	60.00
PIPELAYER	59.00
LABOR\BOXBUILDER HELPER	58.00
TRUCK DRIVER	60.00
ADMIN / OFFICE	85.00
PROJECT MANAGER / ESTIMATOR	115.00
PROJECT STAFF ENGINEER	85.00
SHOP MACHINIST / WELDER FABRICATION	110.00
SHOP LABOR	65.00
SHOP MECHANIC	95.00

OVERTIME LABOR

OT SUPERINTENDANT W/TRUCK	198.00
OT SUPERINTENDANT W/O TRUCK	154.00
OT FOREMAN W/TRUCK	184.00
OT FOREMAN W/O TRUCK	140.00
OT CARPENTER W/TRUCK	134.00
OT CARPENTER	94.00
OT MECHANIC./WELDER W/TRUCK	186.00
OT MECHANIC/WELDER W/O TRK	109.00

EQUIP #	EQUIP DESCRIPTION	MODEL	SIZE	BUCKET SIZE / PAYLOAD	HOURLY BARE RENTAL	OPERATED RATE
	OT OPERATOR					109.00
	OT OILER					105.00
	OT LEADMAN					81.00
	OT PIPELAYER					79.00
	OT LABORER/BOX BUILDER HELPER					77.00
	OT TRUCK DRIVER					75.00
	1/2 OT RATE PM					
	PM RATE SUPERINTENDANT W/TRK					88.00
	PM RATE SUPERINTENDANT W/O TRK					44.00
	PM RATE FOREMAN W/TRUCK					84.00
	PM RATE FOREMAN W/O TRUCK					40.00
	PM RATE MECHANIC/WELDER W/TRK					127.00
	PM MECHANIC/WELDER W/O TRK					50.00
	PM RATE CARPENTER W/TRK					79.00
	PM RATE CARPENTER W/O TRUCK					39.00
	PM RATE OPERATOR					50.00
	PM RATE OILER					49.00
	PM RATE LEADMAN					37.00
	PM RATE PIPELAYER					37.00
	PM RATE LABORER/BB HELPER					36.00
	PM RATE TRUCK DRIVER					43.00

TERMS AND CONDITIONS

1. Mark up + overhead of 10% will be added to all labor, equipment, materials and subcontractors.

2. These T&M rates are subject to change at any time without notice.

Signed: 

Austin Cameron, President

Date: 7/30/2015

EXHIBIT L
NOTICE OF EXEMPTION

NOTICE OF EXEMPTION

(Check one or both)

TO: RECORDER/COUNTY CLERK
P.O. BOX 1750, MS A-33
1600 PACIFIC HWY, ROOM 260
SAN DIEGO, CA 92101-2422

FROM: CITY OF SAN DIEGO
PUBLIC WORKS DEPARTMENT
525 B STREET, SUITE 750, MS 908A
SAN DIEGO, CA 92101

OFFICE OF PLANNING AND RESEARCH
1400 TENTH STREET, ROOM 121
SACRAMENTO, CA 95814

PROJECT/WBS No.: B-17079.02.06 PROJECT TITLE: Storm drain pipe repair at 2582 Manzana Way

PROJECT LOCATION-SPECIFIC: The project is located at 2582 Manzana Way within the Skyline community planning area (Council District 4).

PROJECT LOCATION-CITY/COUNTY: San Diego/San Diego

DESCRIPTION OF NATURE, PURPOSE, AND BENEFICIARIES OF PROJECT: The project would replace in place in the existing trench an 18-inch deteriorated storm drain pipe and repair a sinkhole approximately 15 feet by 18 feet. The area is mapped as urban developed and is not in or adjacent to the MHPA. There would be no impacts to historical resources. A Water Pollution Control Plan (WPCP) will prevent any discharges and exposed soil will be covered with mulch to prevent erosion.

NAME OF PUBLIC AGENCY APPROVING PROJECT: City of San Diego

NAME OF PERSON OR AGENCY CARRYING OUT PROJECT: City of San Diego Public Works Department,
Manuel Gonzalez: 619-533-3471
525 B Street, Suite 750, San Diego, CA 92101

EXEMPT STATUS:

- MINISTERIAL (SEC. 21080(b)(1); 15268);
- DECLARED EMERGENCY (SEC. 21080(b)(3); 15269(a));
- EMERGENCY PROJECT (SEC. 21080(b)(4); 15269(b)(c))
- CATEGORICAL EXEMPTION: SECTIONS 15301 EXISTING FACILITIES AND 15302 REPLACEMENT OR RECONSTRUCTION
- STATUTORY EXEMPTIONS:

REASONS WHY PROJECT IS EXEMPT: The City of San Diego conducted an environmental review which determined that the project meets the categorical exemption criteria set forth in CEQA State Guidelines, SECTIONS 15301 EXISTING FACILITIES AND 15302 REPLACEMENT OR RECONSTRUCTION and where the exceptions listed in Section 15300.2 would not apply.

LEAD AGENCY CONTACT PERSON: CARRIE PURCELL, ASSISTANT DEPUTY DIRECTOR TELEPHONE: 619-533-5124

IF FILED BY APPLICANT:

1. ATTACH CERTIFIED DOCUMENT OF EXEMPTION FINDING.
2. HAS A NOTICE OF EXEMPTION BEEN FILED BY THE PUBLIC AGENCY APPROVING THE PROJECT?
 YES NO

CARRIE PURCELL, ASSISTANT DEPUTY DIRECTOR

12/6/16
DATE

CHECK ONE:

- SIGNED BY LEAD AGENCY
- SIGNED BY APPLICANT

DATE RECEIVED FOR FILING AT OPR:

EXHIBIT M
LOCATION MAP



Manzana Way Storm Drain Emergency Replacement

PROGRAM MANAGER PROJECT MANAGER
Kris Shackelford Manuel Gonzalez
619-533-4121 619-533-3471

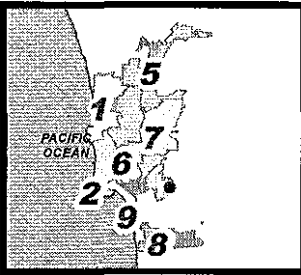
FOR QUESTIONS ABOUT THIS PROJECT
Call: (619) 533-4207
Email: engineering@sandiego.gov



Legend

-  Proposed Cleanout
-  Storm Drain to be Replaced

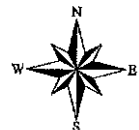

THIS MAP/DATA IS PROVIDED WITHOUT WARRANTY OF ANY KIND, EITHER EXPRESS OR IMPLIED, INCLUDING, BUT NOT LIMITED TO, THE IMPLIED WARRANTIES OR MERCHANTABILITY AND FITNESS FOR A PARTICULAR PURPOSE. Note: This product may contain information reproduced with permission granted by RAND McNALLY & COMPANY® to SanGIS. This map is copyrighted by RAND McNALLY & COMPANY®. It is unlawful to copy or reproduce all or any part thereof, whether for personal use or resale, without the prior, written permission of RAND McNALLY & COMPANY.

EXHIBIT N

STORM WATER APPLICABILITY CHECKLIST (DS-560)



City of San Diego
Development Services
1222 First Ave., MS-302
San Diego, CA 92101
(619) 446-5000

Storm Water Requirements Applicability Checklist

FORM
DS-560
OCTOBER 2016

Project Address:	Project Number (for City Use Only):
------------------	-------------------------------------

SECTION 1. Construction Storm Water BMP Requirements:

All construction sites are required to implement construction BMPs in accordance with the performance standards in the Storm Water Standards Manual. Some sites are additionally required to obtain coverage under the State Construction General Permit (CGP)¹, which is administered by the State Water Resources Control Board.

For all projects complete PART A: If project is required to submit a SWPPP or WPCP, continue to PART B.

PART A: Determine Construction Phase Storm Water Requirements.

1. Is the project subject to California's statewide General NPDES permit for Storm Water Discharges Associated with Construction Activities, also known as the State Construction General Permit (CGP)? (Typically projects with land disturbance greater than or equal to 1 acre.)

- Yes; SWPPP required, skip questions 2-4 No; next question

2. Does the project propose construction or demolition activity, including but not limited to, clearing, grading, grubbing, excavation, or any other activity resulting in ground disturbance and contact with storm water runoff?

- Yes; WPCP required, skip 3-4 No; next question

3. Does the project propose routine maintenance to maintain original line and grade, hydraulic capacity, or original purpose of the facility? (Projects such as pipeline/utility replacement)

- Yes; WPCP required, skip 4 No; next question

4. Does the project only include the following Permit types listed below?

- Electrical Permit, Fire Alarm Permit, Fire Sprinkler Permit, Plumbing Permit, Sign Permit, Mechanical Permit, Spa Permit,
- Individual Right of Way Permits that exclusively include only ONE of the following activities: water service, sewer lateral, or utility service.
- Right of Way Permits with a project footprint less than 150 linear feet that exclusively include only ONE of the following activities: curb ramp, sidewalk and driveway apron replacement, pot holing, curb and gutter replacement, and retaining wall encroachments.

- Yes; no document required

Check one of the boxes below, and continue to PART B:

- If you checked "Yes" for question 1, **a SWPPP is REQUIRED. Continue to PART B**
- If you checked "No" for question 1, and checked "Yes" for question 2 or 3, **a WPCP is REQUIRED.** If the project proposes less than 5,000 square feet of ground disturbance AND has less than a 5-foot elevation change over the entire project area, a Minor WPCP may be required instead. **Continue to PART B.**
- If you checked "No" for all questions 1-3, and checked "Yes" for question 4, **PART B does not apply and no document is required. Continue to Section 2.**

1. More information on the City's construction BMP requirements as well as CGP requirements can be found at: www.sandiego.gov/stormwater/regulations/index.shtml

PART B: Determine Construction Site Priority

This prioritization must be completed within this form, noted on the plans, and included in the SWPPP or WPCP. The city reserves the right to adjust the priority of projects both before and after construction. Construction projects are assigned an inspection frequency based on if the project has a "high threat to water quality." The City has aligned the local definition of "high threat to water quality" to the risk determination approach of the State Construction General Permit (CGP). The CGP determines risk level based on project specific sediment risk and receiving water risk. Additional inspection is required for projects within the Areas of Special Biological Significance (ASBS) watershed. **NOTE:** The construction priority does **NOT** change construction BMP requirements that apply to projects; rather, it determines the frequency of inspections that will be conducted by city staff.

Complete PART B and continued to Section 2

- 1. **ASBS**
a. Projects located in the ASBS watershed.
- 2. **High Priority**
a. Projects 1 acre or more determined to be Risk Level 2 or Risk Level 3 per the Construction General Permit and not located in the ASBS watershed.
b. Projects 1 acre or more determined to be LUP Type 2 or LUP Type 3 per the Construction General Permit and not located in the ASBS watershed.
- 3. **Medium Priority**
a. Projects 1 acre or more but not subject to an ASBS or high priority designation.
b. Projects determined to be Risk Level 1 or LUP Type 1 per the Construction General Permit and not located in the ASBS watershed.
- 4. **Low Priority**
a. Projects requiring a Water Pollution Control Plan but not subject to ASBS, high, or medium priority designation.

SECTION 2. Permanent Storm Water BMP Requirements.

Additional Information for determining the requirements is found in the Storm Water Standards Manual.

PART C: Determine if Not Subject to Permanent Storm Water Requirements.

Projects that are considered maintenance, or otherwise not categorized as "new development projects" or "redevelopment projects" according to the Storm Water Standards Manual are not subject to Permanent Storm Water BMPs.

If "yes" is checked for any number in Part C, proceed to Part F and check "Not Subject to Permanent Storm Water BMP Requirements".

If "no" is checked for all of the numbers in Part C continue to Part D.

- 1. Does the project only include interior remodels and/or is the project entirely within an existing enclosed structure and does not have the potential to contact storm water? Yes No
- 2. Does the project only include the construction of overhead or underground utilities without creating new impervious surfaces? Yes No
- 3. Does the project fall under routine maintenance? Examples include, but are not limited to: roof or exterior structure surface replacement, resurfacing or reconfiguring surface parking lots or existing roadways without expanding the impervious footprint, and routine replacement of damaged pavement (grinding, overlay, and pothole repair). Yes No

PART D: PDP Exempt Requirements.

PDP Exempt projects are required to implement site design and source control BMPs.

If "yes" was checked for any questions in Part D, continue to Part F and check the box labeled "PDP Exempt."

If "no" was checked for all questions in Part D, continue to Part E.

1. Does the project ONLY include new or retrofit sidewalks, bicycle lanes, or trails that:

- Are designed and constructed to direct storm water runoff to adjacent vegetated areas, or other non-erodible permeable areas? Or;
- Are designed and constructed to be hydraulically disconnected from paved streets and roads? Or;
- Are designed and constructed with permeable pavements or surfaces in accordance with the Green Streets guidance in the City's Storm Water Standards manual?

Yes; PDP exempt requirements apply No; next question

2. Does the project ONLY include retrofitting or redeveloping existing paved alleys, streets or roads designed and constructed in accordance with the Green Streets guidance in the City's Storm Water Standards Manual?

Yes; PDP exempt requirements apply No; project not exempt.

PART E: Determine if Project is a Priority Development Project (PDP).

Projects that match one of the definitions below are subject to additional requirements including preparation of a Storm Water Quality Management Plan (SWQMP).

If "yes" is checked for any number in PART E, continue to PART F and check the box labeled "Priority Development Project".

If "no" is checked for every number in PART E, continue to PART F and check the box labeled "Standard Development Project".

1. **New Development that creates 10,000 square feet or more of impervious surfaces collectively over the project site.** This includes commercial, industrial, residential, mixed-use, and public development projects on public or private land.

Yes No

2. **Redevelopment project that creates and/or replaces 5,000 square feet or more of impervious surfaces on an existing site of 10,000 square feet or more of impervious surfaces.** This includes commercial, industrial, residential, mixed-use, and public development projects on public or private land.

Yes No

3. **New development or redevelopment of a restaurant.** Facilities that sell prepared foods and drinks for consumption, including stationary lunch counters and refreshment stands selling prepared foods and drinks for immediate consumption (SIC 5812), and where the land development creates and/or replace 5,000 square feet or more of impervious surface.

Yes No

4. **New development or redevelopment on a hillside.** The project creates and/or replaces 5,000 square feet or more of impervious surface (collectively over the project site) and where the development will grade on any natural slope that is twenty-five percent or greater.

Yes No

5. **New development or redevelopment of a parking lot that creates and/or replaces 5,000 square feet or more of impervious surface (collectively over the project site).**

Yes No

6. **New development or redevelopment of streets, roads, highways, freeways, and driveways.** The project creates and/or replaces 5,000 square feet or more of impervious surface (collectively over the project site).

Yes No

- 7. **New development or redevelopment discharging directly to an Environmentally Sensitive Area.** The project creates and/or replaces 2,500 square feet of impervious surface (collectively over project site), and discharges directly to an Environmentally Sensitive Area (ESA). "Discharging directly to" includes flow that is conveyed overland a distance of 200 feet or less from the project to the ESA, or conveyed in a pipe or open channel any distance as an isolated flow from the project to the ESA (i.e. not commingled with flows from adjacent lands). Yes No
- 8. **New development or redevelopment projects of a retail gasoline outlet (RGO) that create and/or replaces 5,000 square feet of impervious surface.** The development project meets the following criteria: (a) 5,000 square feet or more or (b) has a projected Average Daily Traffic (ADT) of 100 or more vehicles per day. Yes No
- 9. **New development or redevelopment projects of an automotive repair shops that creates and/or replaces 5,000 square feet or more of impervious surfaces.** Development projects categorized in any one of Standard Industrial Classification (SIC) codes 5013, 5014, 5541, 7532-7534, or 7536-7539. Yes No
- 10. **Other Pollutant Generating Project.** The project is not covered in the categories above, results in the disturbance of one or more acres of land and is expected to generate pollutants post construction, such as fertilizers and pesticides. This does not include projects creating less than 5,000 sf of impervious surface and where added landscaping does not require regular use of pesticides and fertilizers, such as slope stabilization using native plants. Calculation of the square footage of impervious surface need not include linear pathways that are for infrequent vehicle use, such as emergency maintenance access or bicycle pedestrian use, if they are built with pervious surfaces or if they sheet flow to surrounding pervious surfaces. Yes No

PART F: Select the appropriate category based on the outcomes of PART C through PART E.

- 1. The project is **NOT SUBJECT TO PERMANENT STORM WATER REQUIREMENTS.**
- 2. The project is a **STANDARD DEVELOPMENT PROJECT.** Site design and source control BMP requirements apply. See the Storm Water Standards Manual for guidance.
- 3. The project is **PDP EXEMPT.** Site design and source control BMP requirements apply. See the Storm Water Standards Manual for guidance.
- 4. The project is a **PRIORITY DEVELOPMENT PROJECT.** Site design, source control, and structural pollutant control BMP requirements apply. See the Storm Water Standards Manual for guidance on determining if project requires a hydromodification plan management

Manuel Gonzalez

Associate Engineer- Civil

Name of Owner or Agent (Please Print)

Title



11/23/16

Signature

Date

EXHIBIT O

ADVANCED METERING INFRASTRUCTURE (AMI) DEVICE PROTECTION

Protecting AMI Devices in Meter Boxes and on Street Lights

The Public Utilities Department (PUD) has begun the installation of the Advanced Metering Infrastructure (AMI) technology as a new tool to enhance water meter reading accuracy and efficiency, customer service and billing, and to be used by individual accounts to better manage the efficient use of water. **All AMI devices shall be protected per Section 5-2, "Protection", of the 2015 Whitebook.**

AMI technology allows water meters to be read electronically rather than through direct visual inspection by PUD field staff. This will assist PUD staff and customers in managing unusual consumption patterns which could indicate leaks or meter tampering on a customer's property.

Three of the main components of an AMI system are the:

- A. Endpoints, see Photo 1:

Photo 1

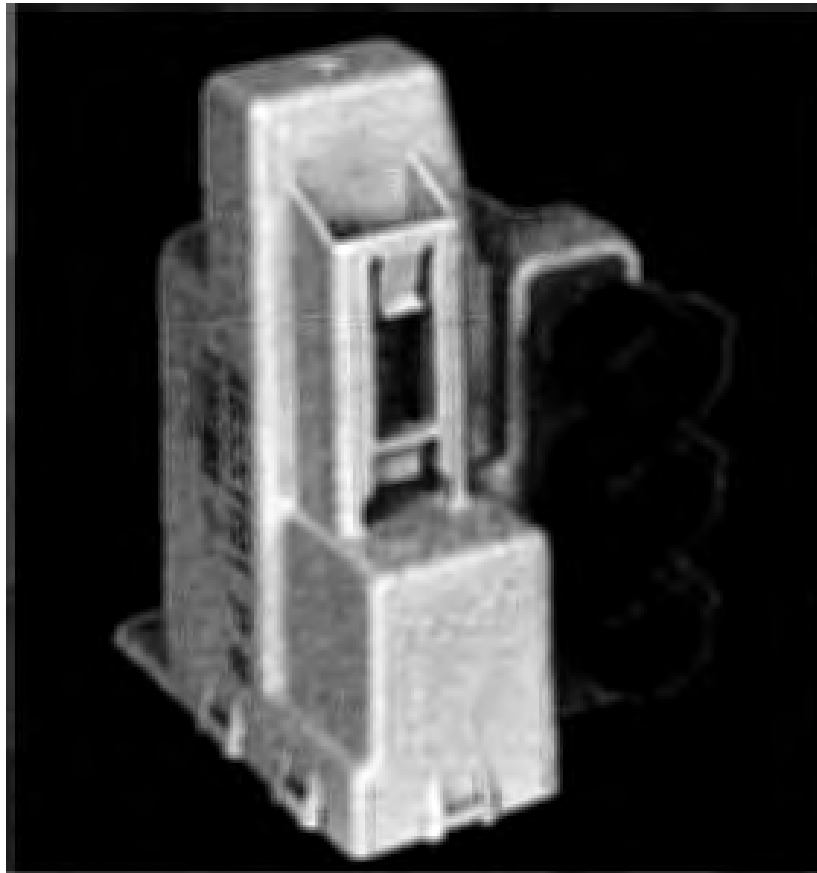

B. AMI Antenna attached to Endpoint (antenna not always required), see Photo 2:

Photo 2

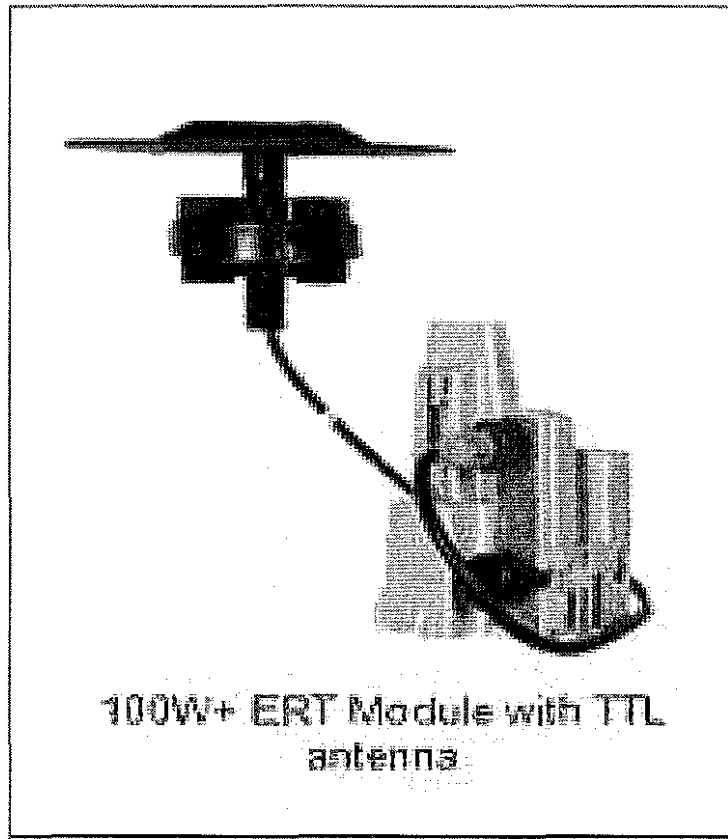

Network Devices, see Photo 3:

Photo 3

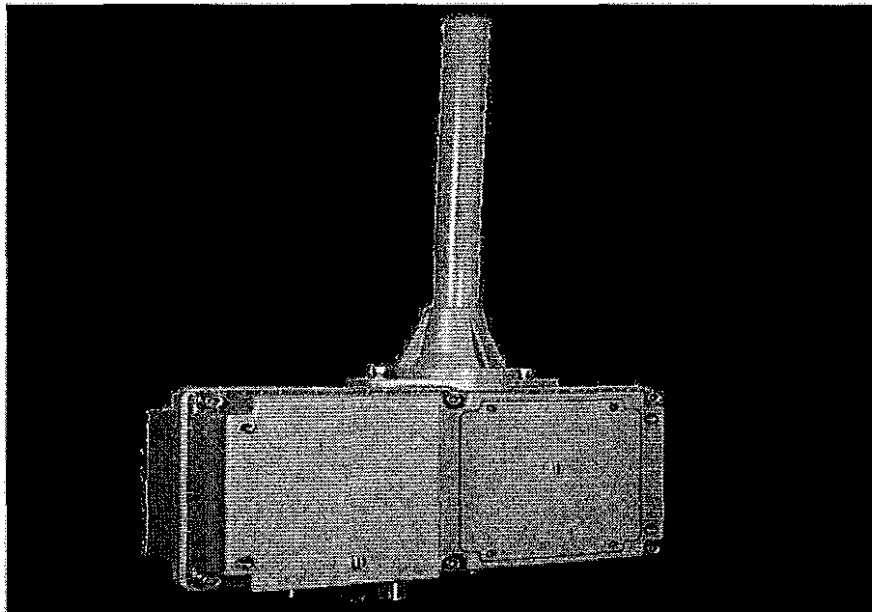

AMI endpoints transmit meter information to the AMI system and will soon be on the vast majority of meters in San Diego. These AMI devices provide interval consumption data to the PUD's Customer Support Division. If these devices are damaged or communication is interrupted, this Division will be alerted of the situation. The endpoints are installed in water meter boxes, coffins, and vaults adjacent to the meter. A separate flat round antenna may also be installed through the meter box lid. This antenna is connected to the endpoint via cable. The following proper installation shall be implemented when removing the lid to avoid damaging the antenna, cable, and/or endpoint. Photo 4 below demonstrates a diagram of the connection:

Photo 4

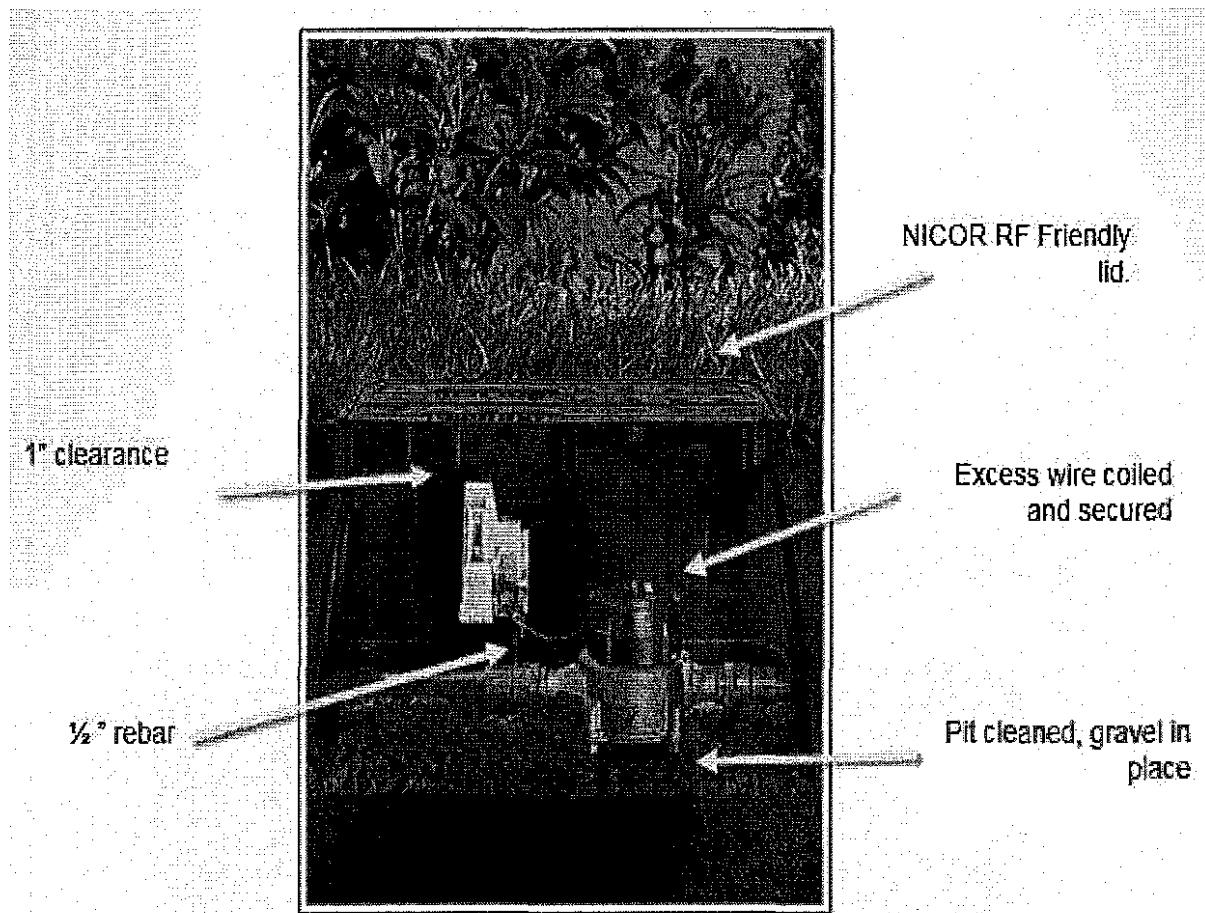

The AMI device ERT/Endpoint/Transmitter shall be positioned and installed as discussed in this Appendix. If the ERT/Endpoint/Transmitter is disturbed, it shall be re-installed and returned to its original installation with the end points pointed upwards as shown below in Photo 5.

The PUD's code compliance staff will issue citations and invoices to you for any damaged AMI devices that are not re-installed as discussed in the Contract Document

Photo 5 below shows a typical installation of an AMI endpoint on a water meter.

Photo 5

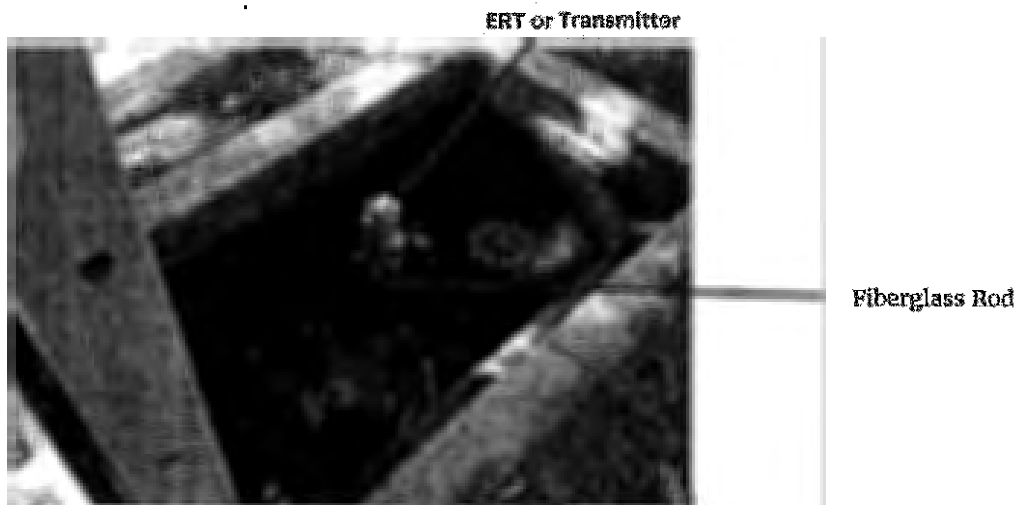

Photo 6 below is an example of disturbance that shall be avoided:

Photo 6

The antenna was drilled into the lid and now it is removed.



The ERT has been disconnected from the water meter

The endpoint is taken off the rod which is the original installation location

You are responsible when working in and around meter boxes. If you encounter these endpoints, use proper care and do not disconnect them from the registers on top of the water meter. If the lid has an antenna drilled through, do not change or tamper with the lid and inform the Resident Engineer immediately about the location of that lid. Refer to Photo 7 below:

Photo 7

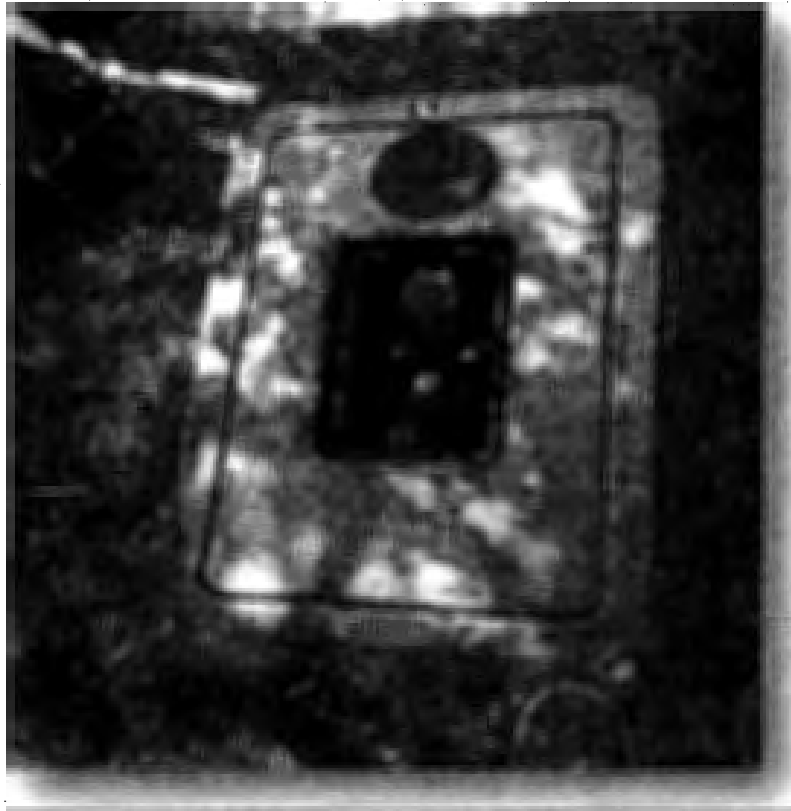

Another component of the AMI system are the Network Devices. The Network Devices are strategically placed units (mainly on street light poles) that collect interval meter reading data from multiple meters for transmission to the Department Control Computer. **If you come across any of these devices on street lights that will be removed or replaced (refer to Photos 8 and 9 below), notify AMI Project Manager Arwa Sayed at (619) 362-0121 immediately.**

Photo 8 shows an installed network device on a street light. On the back of each Network Device is a sticker with contact information. See Photo 9. **Call PUD Water Emergency Repairs at 619-515-3525 if your work will impact these street lights.** These are assets that belong to the City of San Diego and you shall be responsible for any costs of disruption of this network.

Photo 8



Network Device

Photo 9



If you encounter any bad installations, disconnected/broken/buried endpoints, or inadvertently damage any AMI devices or cables, notify the Resident Engineer immediately. The Resident Engineer will then immediately contact the AMI Project Manager, Arwa Sayed, at (619) 362-0121.