

City of San Diego

ORIGINAL

CONTRACTOR'S NAME: Blue Pacific Engineering & Construction
ADDRESS: 7330 Opportunity Road, Suite J, San Diego, CA 92111
TELEPHONE NO.: 858-956-1456 FAX NO.: 619-291-0482
CITY CONTACT: CLEMENTINA GIORDANO, Contract Specialist, Email: Cgiordano@saniego.gov
Phone No. (619) 533-3481, Fax No. (619) 533-3633
C.Goodrich/RWBustamante/egz

CONTRACT DOCUMENTS

FOR

TRAIL FOR ALL PEOPLE

VOLUME 1 OF 2



BID NO.: L-16-1240-DBB-1
SAP NO. (WBS/IO/CC): S-13001
CLIENT DEPARTMENT: 1714
COUNCIL DISTRICT: 5
PROJECT TYPE: GD

THIS CONTRACT IS SUBJECT TO THE FOLLOWING:

- THE CITY'S SUBCONTRACTING PARTICIPATION REQUIREMENTS FOR SLBE PROGRAM.
- COMPETITION RESTRICTED TO: SLBE-ELBE or ELBE FIRMS ONLY .
- PREVAILING WAGE RATES: STATE FEDERAL
- APPRENTICESHIP

BID DUE DATE:

**1:30 PM
SEPTEMBER 2, 2015
CITY OF SAN DIEGO
PUBLIC WORKS CONTRACTS
1010 SECOND AVENUE, 14th FLOOR, MS 614C
SAN DIEGO, CA 92101**

20150902142400 MC

ENGINEER OF WORK

The engineering Specifications and Special Provisions contained herein have been prepared by or under the direction of the following Registered Engineer:

Michael S. White

1) Registered Engineer

7/29/15

Date

Seal:



Ali Darvishi

2) For City Engineer

7/28/15

Date

Seal:

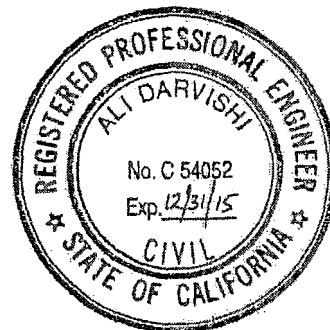

TABLE OF CONTENTS

DESCRIPTION	PAGE NUMBER
1. NOTICE INVITING BIDS.....	4
2. CONTRACT FORMS AGREEMENT:	
1. Contract Forms.....	16
3. CONTRACT FORMS ATTACHMENTS:	
2. Performance Bond and Labor and Materialmen’s Bond.....	19
3. Drug-Free Workplace.....	21
4. American with Disabilities Act (ADA) Compliance Certification	22
5. Contractor Standards - Pledge of Compliance Certificate	23
6. Affidavit of Disposal Certificate	24
4. ATTACHMENTS:	
A. SCOPE OF WORK.....	26
B. INTENTIONALLY LEFT BLANK.....	28
C. EQUAL OPPORTUNITY CONTRACTING PROGRAM	29
D. INTENTIONALLY LEFT BLANK.....	33
E. SUPPLEMENTARY SPECIAL PROVISIONS	34
TECHNICALS	46
SUPPLEMENTARY SPECIAL PROVISIONS APPENDICES:.....	78
1. Appendix A - Final Mitigated Negative Declaration and Site Development Permit....	79
2. Appendix B - Fire Hydrant Meter Program	106
3. Appendix C - Materials Typically Accepted by Certificate of Compliance	120
4. Appendix D - Sample City Invoice	122
5. Appendix E - Vicinity Map.....	124
6. Appendix F - Sample of Public Notices	126
F. INTENTIONALLY LEFT BLANK.....	128

CITY OF SAN DIEGO, CALIFORNIA

NOTICE INVITING BIDS

1. **LIMITED COMPETITION:** This contract may only be bid by the Contractors on the City's approved SLBE-ELBE Construction Contractors List in accordance with the designation stated on the cover page hereof. For information regarding the SLBE-ELBE Construction Program and registration visit the City's web site: <http://www.sandiego.gov>.
2. **RECEIPT AND OPENING OF BIDS:** Bids will be received at the Public Works Contracts at the location, time, and date shown on the cover of these specifications for performing work on **Trail For All People** (Project).
3. **SUMMARY OF WORK:** The Work involves furnishing all labor, materials, equipment, services, and other incidental works and appurtenances for the construction of the Project as described in ATTACHMENT A.
4. **BIDS ARE PUBLIC RECORDS:** Upon receipt by the City, Bids shall become public records subject to public disclosure. It is the responsibility of the respondent to clearly identify any confidential, proprietary, trade secret or otherwise legally privileged information contained within the Bid. General references to sections of the California Public Records Act (PRA) will not suffice. If the Contractor does not provide applicable case law that clearly establishes that the requested information is exempt from the disclosure requirements of the PRA, the City shall be free to release the information when required in accordance with the PRA, pursuant to any other applicable law, or by order of any court or government agency, and the Contractor will hold the City harmless for release of this information.
5. **SUBCONTRACTING PARTICIPATION PERCENTAGES:**
 - 5.1. The City has incorporated voluntary subcontractor participation percentage to enhance competition and maximize subcontracting opportunities as follows.
 - 5.2. The following voluntary subcontractor participation percentage for DBE, DVBE, WBE, MBE, SLBE, and ELBE certified Subcontractors shall apply to this contract:

Total voluntary subcontractor participation percentage for this project is 13.4%.
 - 5.3. For additional Equal Opportunity Contracting Program requirements, see Attachment C.
6. **PRE-BID MEETING:**
 - 6.1. There will be a Pre-Bid Meeting to discuss the scope of the Project, bidding requirements, pre-qualification process, and Equal Opportunity Contracting Program requirements and reporting procedures in the Public Works Contracts Conference Room, at 1010 Second Avenue 14th Floor, San Diego, CA 92101, at **10:00 AM, on AUGUST 12, 2015.**
 - 6.2. **The Pre-Bid Meeting has been designated as MANDATORY. All potential bidders are required to attend.** Bid will be declared **non-responsive** if the Bidder

fails to attend the Pre-Bid Meeting when specified to be mandatory. Attendance at the Pre-Bid Meeting will be evidenced by the representative's signature on the attendance roster. It shall be the responsibility of the Bidder's representative to complete and sign the attendance roster. **No Bidder will be admitted after the specified start time of the mandatory Pre-Bid Meeting.**

- 6.3. To request a copy of the agenda on an alternative format, or to request a sign language or oral interpreter for this meeting, call the Public Works Contracts at (619) 533-3450 at least 5 Working Days prior to the Pre-Bid Meeting to ensure availability.
7. **CONTRACTOR REGISTRATION AND ELECTRONIC REPORTING SYSTEM:**
- 7.1. **Prior** to the Award of the Contract or each Task Order, you and your Subcontractors and Suppliers must register with the City's web-based vendor registration and bid management system, BidsOnline™ hosted by PlanetBids System. For additional information go to:
- <http://www.sandiego.gov/purchasing/bids-contracts/vendorreg.shtml>.
- 7.2. The City may not award the contract until registration of all subcontractors and suppliers is complete. In the event this requirement is not met within the time frame specified in the Notice of Intent to Award letter, the City reserves the right to rescind the Notice of Award / Intent to Award and to make the award to the next responsive and responsible bidder / proposer.
8. **PRE-BID SITE VISIT: The Pre-Bid Visit has been designated as MANDATORY. The prospective Bidders are required to visit the Work Site with the Engineer.** The purpose of the Site visit is to acquaint Bidders with the Site conditions. To request a sign language or oral interpreter for this visit, call the Public Works Contracts at (619) 533-3450 at least 5 Working Days prior to the meeting to ensure availability. A Pre-Bid Site Visit is offered when the details are provided as follows:
- Time: 11:00 AM**
Date: AUGUST 12, 2015
Location: Off of Black Mountain Miner's Ridge Loop
(See Appendix E, Location Map)
9. **JOINT VENTURE CONTRACTORS:** Provide a copy of the Joint Venture agreement and the Joint Venture license to the City within 10 Working Days after receiving the Contract forms. See 2-1.1.2, "Joint Venture Contractors" in The WHITEBOOK for details.
10. **PREVAILING WAGE RATES:** Pursuant to San Diego Municipal Code section 22.3019, construction, alteration, demolition, repair and maintenance work performed under this Contract is subject to State prevailing wage laws. For construction work performed under this Contract cumulatively exceeding \$25,000 and for alteration, demolition, repair and maintenance work performed under this Contract cumulatively exceeding \$15,000, the Contractor and its subcontractors shall comply with State prevailing wage laws including, but not limited to, the requirements listed below.
- 10.1. **Compliance with Prevailing Wage Requirements.** Pursuant to sections 1720 through 1861 of the California Labor Code, the Contractor and its subcontractors

shall ensure that all workers who perform work under this Contract are paid not less than the prevailing rate of per diem wages as determined by the Director of the California Department of Industrial Relations (DIR). This includes work performed during the design and preconstruction phases of construction including, but not limited to, inspection and land surveying work.

10.1.1. Copies of such prevailing rate of per diem wages are on file at the City and are available for inspection to any interested party on request. Copies of the prevailing rate of per diem wages also may be found at <http://www.dir.ca.gov/OPRL/DPreWageDetermination.htm>. Contractor and its subcontractors shall post a copy of the prevailing rate of per diem wages determination at each job site and shall make them available to any interested party upon request.

10.1.2. The wage rates determined by the DIR refer to expiration dates. If the published wage rate does not refer to a predetermined wage rate to be paid after the expiration date, then the published rate of wage shall be in effect for the life of this Contract. If the published wage rate refers to a predetermined wage rate to become effective upon expiration of the published wage rate and the predetermined wage rate is on file with the DIR, such predetermined wage rate shall become effective on the date following the expiration date and shall apply to this Contract in the same manner as if it had been published in said publication. If the predetermined wage rate refers to one or more additional expiration dates with additional predetermined wage rates, which expiration dates occur during the life of this Contract, each successive predetermined wage rate shall apply to this Contract on the date following the expiration date of the previous wage rate. If the last of such predetermined wage rates expires during the life of this Contract, such wage rate shall apply to the balance of the Contract.

10.2. Penalties for Violations. Contractor and its subcontractors shall comply with California Labor Code section 1775 in the event a worker is paid less than the prevailing wage rate for the work or craft in which the worker is employed.

10.3. Payroll Records. Contractor and its subcontractors shall comply with California Labor Code section 1776, which generally requires keeping accurate payroll records, verifying and certifying payroll records, and making them available for inspection. Contractor shall require its subcontractors to also comply with section 1776. Contractor and its subcontractors shall submit weekly certified payroll records online via the City's web-based Labor Compliance Program. Contractor is responsible for ensuring its subcontractors submit certified payroll records to the City.

10.3.1. For contracts entered into on or after April 1, 2015, Contractor and their subcontractors shall furnish records specified in Labor Code section 1776 directly to the Labor Commissioner in the manner required by Labor Code section 1771.4.

10.4. Apprentices. Contractor and its subcontractors shall comply with California Labor Code sections 1777.5, 1777.6 and 1777.7 concerning the employment and wages of apprentices. Contractor is held responsible for the compliance of their subcontractors with sections 1777.5, 1777.6 and 1777.7.

- 10.5. Working Hours.** Contractor and their subcontractors shall comply with California Labor Code sections 1810 through 1815, including but not limited to: (i) restrict working hours on public works contracts to eight hours a day and forty hours a week, unless all hours worked in excess of 8 hours per day are compensated at not less than 1½ times the basic rate of pay; and (ii) specify penalties to be imposed on design professionals and subcontractors of \$25 per worker per day for each day the worker works more than 8 hours per day and 40 hours per week in violation of California Labor Code sections 1810 through 1815.
- 10.6. Required Provisions for Subcontracts.** Contractor shall include at a minimum a copy of the following provisions in any contract they enter into with a subcontractor: California Labor Code sections 1771, 1771.1, 1775, 1776, 1777.5, 1810, 1813, 1815, 1860 and 1861.
- 10.7. Labor Code Section 1861 Certification.** Contractor in accordance with California Labor Code section 3700 is required to secure the payment of compensation of its employees and by signing this Contract, Contractor certifies that “I am aware of the provisions of Section 3700 of the California Labor Code which require every employer to be insured against liability for workers’ compensation or to undertake self-insurance in accordance with the provisions of that code, and I will comply with such provisions before commencing the performance of the work of this Contract.”
- 10.8. Labor Compliance Program.** The City has its own Labor Compliance Program authorized in August 2011 by the DIR. The City will withhold contract payments when payroll records are delinquent or deemed inadequate by the City or other governmental entity, or it has been established after an investigation by the City or other governmental entity that underpayment(s) have occurred. For questions or assistance, please contact the City of San Diego’s Equal Opportunity Contracting Department at 619-236-6000.
- 10.9. Contractor and Subcontractor Registration Requirements.** This project is subject to compliance monitoring and enforcement by the DIR. As of March 1, 2015, no contractor or subcontractor may be listed on a bid or proposal for a public works project unless registered with the DIR pursuant to Labor Code section 1725.5. As of April 1, 2015, a contractor or subcontractor shall not be qualified to bid on, be listed in a bid proposal, or enter into any contract for public work, unless currently registered and qualified to perform public work pursuant to Labor Code section 1725.5. By submitting a bid or proposal to the City, Contractor is certifying that he or she has verified that all subcontractors used on this public work project are registered with the DIR in compliance with Labor Code sections 1771.1 and 1725.5, and Contractor shall provide proof of registration to the City upon request.
- 10.9.1.** A Contractor’s inadvertent error in listing a subcontractor who is not registered pursuant to Labor Code section 1725.5 in response to a solicitation shall not be grounds for filing a bid protest or grounds for considering the bid non-responsive provided that any of the following apply: (1) the subcontractor is registered prior to bid opening; (2) within twenty-four hours after the bid opening, the subcontractor is registered and has paid the penalty registration fee specified in Labor Code section 1725.5; or (3) the subcontractor is replaced by another registered subcontractor pursuant to Public Contract Code section 4107.

11. INSURANCE REQUIREMENTS:

- 11.1. All certificates of insurance and endorsements required by the contract are to be provided upon issuance of the City's Notice of Intent to Award letter.
- 11.2. Refer to sections 7-3, "LIABILITY INSURANCE", and 7-4, "WORKERS' COMPENSATION INSURANCE" of the Supplementary Special Provisions (SSP) for the insurance requirements which must be met.

12. PREQUALIFICATION OF CONTRACTORS:

- 12.1. Contractors submitting Bid must be pre-qualified for the total amount proposed, inclusive of all alternate items prior to the date of submittal. Bids from contractors who have not been pre-qualified as applicable and Bids that exceed the maximum dollar amount at which contractors are pre-qualified will be deemed **non-responsive** and ineligible for award. Complete information and links to the online prequalification application are available at:

<http://www.sandiego.gov/cip/bidopps/prequalification.shtml>

- 12.2. The completed application must be submitted online to the Public Works Contracts, Prequalification Program no later than 2 weeks prior to the bid opening. For additional information or the answer to questions about the prequalification program, contact David Stucky at 619-533-3474 or dstucky@sandiego.gov.
- 12.3. As a result of the City's fiduciary requirement to safeguard vendor data, City staff will not be able to provide information regarding contractors' prequalification status over the telephone. Contractors may access real-time information about their prequalification status via their vendor profile on [PlanetBids™](#).

13. REFERENCE STANDARDS: Except as otherwise noted or specified, the Work shall be completed in accordance with the following standards:

Title	Edition	Document Number
Standard Specifications for Public Works Construction ("The GREENBOOK")	2012	PITS070112-01
City of San Diego Standard Specifications for Public Works Construction ("The WHITEBOOK")*	2012	PITS070112-02
City of San Diego Standard Drawings*	2012	PITS070112-03
California MUTCD	2012	PITS070112-06
City Standard Drawings - Updates Approved For Use (when specified)*	Varies	Varies
Standard Federal Equal Employment Opportunity Construction Contract Specifications and the Equal Opportunity Clause Dated 09-11-84	1984	769023
NOTE: *Available online under Engineering Documents and References at: http://www.sandiego.gov/publicworks/edocref/index.shtml		

14. **CITY'S RESPONSES AND ADDENDA:** The City at its option, may respond to any or all questions submitted in writing, via letter, or FAX in the form of an addendum. No oral comment shall be of any force or effect with respect to this solicitation. The changes to the Contract Documents through addendum are made effective as though originally issued with the Bid. The Bidders shall acknowledge the receipt of Addenda on the form provided for this purpose in the Bid.
15. **CITY'S RIGHTS RESERVED:** The City reserves the right to cancel the Notice Inviting Bids at any time, and further reserves the right to reject submitted Bids, without giving any reason for such action, at its sole discretion and without liability. Costs incurred by the Bidder(s) as a result of preparing Bids under the Notice Inviting Bids shall be the sole responsibility of each bidder. The Notice Inviting Bids creates or imposes no obligation upon the City to enter a contract.
16. **CONTRACT PRICING FORMAT:** This solicitation is for a Lump Sum contract with Unit Price provisions as set forth in the Bid Proposal Form(s), Volume 2.
17. **SUBMITTAL OF "OR EQUAL" ITEMS:** See Section 4-1.6, "Trade Names or Equals" in The WHITEBOOK and as amended in the SSP.
18. **AWARD PROCESS:**
 - 18.1. The Award of this contract is contingent upon the Contractor's compliance with all conditions precedent to Award.
 - 18.2. Upon acceptance of a Bid, the City will prepare contract documents for execution within approximately 21 days of the date of the Bid opening and award the Contract approximately within 7 days of receipt of properly executed Contract, bonds, and insurance documents.
 - 18.3. This contract will be deemed executed, and effective, only upon the signing of the Contract by the Mayor or designee of the City.
19. **SUBCONTRACT LIMITATIONS:** The Bidder's attention is directed to Standard Specifications for Public Works Construction, Section 2-3, "SUBCONTRACTS" in The GREENBOOK and as amended in the SSP which requires the Contractor to self-perform not less than the specified amount. Failure to comply with this requirement shall render the bid **non-responsive** and ineligible for award.
20. **AVAILABILITY OF PLANS AND SPECIFICATIONS:** Contract Documents may be obtained by visiting the City's website: <http://www.sandiego.gov/cip/>. Plans and Specifications for this contract are also available for review in the office of the City Clerk or Public Works Contracts.
21. **SUBMISSION OF QUESTIONS:**
 - 21.1. The Director (or designee), of the Public Works Department is the officer responsible for opening, examining, and evaluating the competitive Bids submitted to the City for the acquisition, construction and completion of any public improvement except when otherwise set forth in these documents. All questions related to this solicitation shall be submitted to:

Public Works Contracts
1010 Second Avenue, 14th Floor
San Diego, California, 92101
Attention: [Contract Specialist listed on the front cover hereof]

OR:

Email address of the Contract Specialist listed on the front cover hereof.

- 21.2. Questions received less than 14 days prior to the date for opening of Bids may not be considered.
 - 21.3. Clarifications deemed by the City to be material shall be issued by Addenda and uploaded to the City's online bidding service.
 - 21.4. Only questions answered by formal written addenda will be binding. Oral and other interpretations or clarifications will be without legal effect. It is the Bidder's responsibility to become informed of any Addenda that have been issued and to include all such information in its Bid.
22. **ELIGIBLE BIDDERS:** No person, firm, or corporation shall be allowed to make, file, or be interested in more than one (1) Bid for the same work unless alternate Bids are called for. A person, firm or corporation who has submitted a sub-proposal to a Bidder, or who has quoted prices on materials to a Bidder, is not hereby disqualified from submitting a sub-proposal or quoting prices to other Bidders or from submitting a Bid in its own behalf. Any Bidder who submits more than one bid will result in the rejection of all bids submitted.
23. **SAN DIEGO BUSINESS TAX CERTIFICATE:** The Contractor and Subcontractors, not already having a City of San Diego Business Tax Certificate for the work contemplated shall secure the appropriate certificate from the City Treasurer, Civic Center Plaza, first floor and submit to the Contract Specialist upon request or as specified in the Contract Documents. Tax Identification numbers for both the Bidder and the listed Subcontractors must be submitted on the City provided forms with the Notice Inviting Bids and Contract forms.
24. **PROPOSAL FORMS:** Bid shall be made only upon the Bidding Documents i.e., Proposal form attached to and forming a part of the specifications. The signature of each person signing shall be in longhand.
- 24.1. Bidder shall complete and submit all pages in the "Bidding Document" Section (see Volume 2) as their Bid per the schedule given under "Required Documents Schedule," (see Volume 1). Bidder is requested to retain for their reference other portions of the Contract Documents that are not required to be submitted with the Bid. The entire specifications for the bid package do not need to be submitted with the bid.
 - 24.2. The City may require any Bidder to furnish a statement of experience, financial responsibility, technical ability, equipment, and references.
 - 24.3. Bids and certain other forms and documents as specified in the Volume 2 of 2 of the Contract Documents shall be enclosed in a sealed envelope and shall bear the title of the work and name of the Bidder and the appropriate State Contractors License designation which the Bidder holds.

24.4. Bids may be withdrawn by the Bidder prior to, but not after, the time fixed for opening of Bids.

25. AWARD OF CONTRACT OR REJECTION OF BIDS:

25.1. This contract may be awarded to the lowest responsible and reliable Bidder.

25.2. Bidders shall complete the entire Bid schedule (also referred to as “schedule of prices” or Proposal form). Incomplete price schedules will be rejected as being non-responsive.

25.3. The City reserves the right to reject any or all Bids, and to waive any informality or technicality in Bids received and any requirements of these specifications as to bidding procedure.

25.4. Bidders will not be released on account of their errors of judgment. Bidders may be released only upon receipt by the City from the Bidder within 3 Working Days, excluding Saturdays, Sundays, and state holidays, after the opening of Bids, of written notice which includes proof of honest, credible, clerical error of material nature, free from fraud or fraudulent intent, and of evidence that reasonable care was observed in the preparation of the Bid.

25.5. A bidder who is not selected for contract award may protest the award of a contract to another bidder by submitting a written protest in accordance with section 22.3017 of the San Diego Municipal Code.

25.6. The City of San Diego will not discriminate with regard to race, religious creed, color, national origin, ancestry, physical handicap, marital status, sex or age, in the award of contracts.

25.7. Each Bid package properly executed as required by these specifications shall constitute a firm offer, which may be accepted by the City within the time specified in the Proposal.

25.8. The City reserves the right to evaluate all Bids and determine the lowest Bidder on the basis of any proposed alternates, additive items or options, at its discretion that will be disclosed in the Volume 2 of 2.

26. BID RESULTS:

26.1. The Bid opening by the City shall constitute the public announcement of the Apparent Low Bidder. In the event that the Apparent Low Bidder is subsequently deemed non-responsive or non-responsible, a public announcement will be posted in the City’s web page <http://www.sandiego.gov/cip/index.shtml>, with the name of the newly designated Apparent Low Bidder.

26.2. To obtain Bid results, either attend Bid opening, review the results on the City’s web site, or provide a self-addressed, stamped envelope, referencing Bid number, and Bid tabulation will be mailed to you upon verification of extensions. Bid results cannot be given over the telephone.

27. THE CONTRACT:

- 27.1.** The Bidder to whom award is made shall execute a written contract with the City of San Diego and furnish good and approved bonds and insurance certificates specified by the City within 14 days after receipt by Bidder of a form of contract for execution unless an extension of time is granted to the Bidder in writing.
- 27.2.** If the Bidder takes longer than 14 days to fulfill these requirements, then the additional time taken shall be added to the Bid guarantee. The Contract shall be made in the form adopted by the City, which includes the provision that no claim or suit whatsoever shall be made or brought by Contractor against any officer, agent, or employee of the City for or on account of anything done or omitted to be done in connection with this contract, nor shall any such officer, agent, or employee be liable hereunder.
- 27.3.** If the Bidder to whom the award is made fails to enter into the contract as herein provided, the award may be annulled and the Bidder's Guarantee of Good Faith will be subject to forfeiture. An award may be made to the next lowest responsible and reliable Bidder who shall fulfill every stipulation embraced herein as if it were the party to whom the first award was made.
- 27.4.** Pursuant to the San Diego City Charter section 94, the City may only award a public works contract to the lowest responsible and reliable Bidder. The City will require the Apparent Low Bidder to (i) submit information to determine the Bidder's responsibility and reliability, (ii) execute the Contract in form provided by the City, and (iii) furnish good and approved bonds and insurance certificates specified by the City within 14 Days, unless otherwise approved by the City, in writing after the Bidder receives notification from the City, designating the Bidder as the Apparent Low Bidder and formally requesting the above mentioned items.
- 27.5.** The award of the Contract is contingent upon the satisfactory completion of the above mentioned items and becomes effective upon the signing of the Contract by the Mayor or designee. If the Apparent Low Bidder does not execute the Contract or submit required documents and information, the City may award the Contract to the next lowest responsible and reliable Bidder who shall fulfill every condition precedent to award. A corporation designated as the Apparent Low Bidder shall furnish evidence of its corporate existence and evidence that the officer signing the Contract and bond for the corporation is duly authorized to do so.

28. EXAMINATION OF PLANS, SPECIFICATIONS, AND SITE OF WORK: The Bidder shall examine carefully the Project Site, the Plans and Specifications, other materials as described in the Special Provisions, Section 2-7, and the proposal forms (e.g., Bidding Documents). The submission of a Bid shall be conclusive evidence that the Bidder has investigated and is satisfied as to the conditions to be encountered, as to the character, quality, and scope of Work, the quantities of materials to be furnished, and as to the requirements of the Bidding Documents Proposal, Plans, and Specifications.

29. CITY STANDARD PROVISIONS: This contract is subject to the following standard provisions. See The WHITEBOOK for details.

- 29.1.** The City of San Diego Resolution No. R-277952 adopted on May 20, 1991 for a Drug-Free Workplace.

- 29.2. The City of San Diego Resolution No. R-282153 adopted on June 14, 1993 related to the Americans with Disabilities Act.
- 29.3. The City of San Diego Municipal Code §22.3004 for Pledge of Compliance.
- 29.4. The City of San Diego's Labor Compliance Program and the State of California Labor Code §§1771.5(b) and 1776.
- 29.5. Sections 1777.5, 1777.6, and 1777.7 of the State of California Labor Code concerning the employment of apprentices by contractors and subcontractors performing public works contracts.
- 29.6. The City's Equal Benefits Ordinance (EBO), Chapter 2, Article 2, Division 43 of The San Diego Municipal Code (SDMC).
- 29.7. The City's Information Security Policy (ISP) as defined in the City's Administrative Regulation 90.63.

30. PRE-AWARD ACTIVITIES:

- 30.1. The selected contractor by the City to execute a contract for this Work shall provide the information required within the time specified in "Required Documents," of this bid package. Failure to provide the information within the time specified may result in the Bid being rejected as **non-responsive**.
- 30.2. If the Bid is rejected as non-responsive, the selected contractor by the City to execute a contract for this Work shall forfeit the required Bid. The decision that the selected contractor by the City to execute a contract for this Work is non-responsive for failure to provide the information required within the time specified shall be at the sole discretion of the City.

31. REQUIRED DOCUMENT SCHEDULE:

- 31.1. The Bidder's attention is directed to the City's Municipal Code §22.0807(e), (3)-(5) for important information regarding grounds for debarment for failure to submit required documentation.
- 31.2. The specified Equal Opportunity Contracting Program (EOCP) forms are available for download from the City's web site at:

<http://www.sandiego.gov/eoc/forms/index.shtml>

ITEM	WHEN DUE	FROM	DOCUMENT TO BE SUBMITTED
1.	BID SUBMITTAL DATE/TIME	ALL BIDDERS	Bid
2.	BID SUBMITTAL DATE/TIME	ALL BIDDERS	Non-collusion Affidavit to be Executed By Bidder and Submitted with Bid under 23 USC 112 and PCC 7106

ITEM	WHEN DUE	FROM	DOCUMENT TO BE SUBMITTED
3.	BID SUBMITTAL DATE/TIME	ALL BIDDERS	Contractors Certification of Pending Actions
4.	BID SUBMITTAL DATE/TIME	ALL BIDDERS	Equal Benefits Ordinance Certification of Compliance
5.	BID SUBMITTAL DATE/TIME	ALL BIDDERS	Form AA35 - List of Subcontractors
6.	BID SUBMITTAL DATE/TIME	ALL BIDDERS	Form AA40 - Named Equipment/Material Supplier List
7.	WITHIN 10 WORKING DAYS AFTER RECEIPT BY BIDDER OF CONTRACT FORMS	APPARENT LOW BIDDER	Names of the principal individual owners of the Apparent Low Bidder
8.	WITHIN 10 WORKING DAYS AFTER RECEIPT BY BIDDER OF CONTRACT FORMS	APPARENT LOW BIDDER	If the Contractor is a Joint Venture: <ul style="list-style-type: none"> • Joint Venture Agreement • Joint Venture License
9.	WITHIN 10 WORKING DAYS AFTER RECEIPT BY BIDDER OF CONTRACT FORMS	APPARENT LOW BIDDER	Form BB05 - Work Force Report
10.	WITHIN 10 WORKING DAYS AFTER RECEIPT BY BIDDER OF CONTRACT FORMS	APPARENT LOW BIDDER	Contract Forms - Agreement
11.	WITHIN 10 WORKING DAYS AFTER RECEIPT BY BIDDER OF CONTRACT FORMS	APPARENT LOW BIDDER	Contract Forms - Payment and Performance Bond
12.	WITHIN 10 WORKING DAYS AFTER RECEIPT BY BIDDER OF CONTRACT FORMS	APPARENT LOW BIDDER	Certificates of Insurance and Endorsements
13.	WITHIN 10 WORKING DAYS AFTER RECEIPT BY BIDDER OF CONTRACT FORMS	APPARENT LOW BIDDER	Contractor Certification - Drug-Free Workplace
14.	WITHIN 10 WORKING DAYS AFTER RECEIPT BY BIDDER OF CONTRACT FORMS	APPARENT LOW BIDDER	Contractor Certification - American with Disabilities Act
15.	WITHIN 10 WORKING DAYS AFTER RECEIPT BY BIDDER OF CONTRACT FORMS	APPARENT LOW BIDDER	Contractors Standards - Pledge of Compliance

**CONTRACT FORMS
AGREEMENT**

CONTRACT FORMS

CONSTRUCTION CONTRACT

This contract is made and entered into between THE CITY OF SAN DIEGO, a municipal corporation, herein called "City", and **Blue Pacific Engineering & Construction**, herein called "Contractor" for construction of **Trail for All People, Bid No. L-16-1240-DBB-1**; in the amount of **Two Hundred Thirty Eight Thousand Five Hundred Dollars and 00/100 (\$238,500.00)**, which is comprised of the Base Bid only.

IN CONSIDERATION of the payments to be made hereunder and the mutual undertakings of the parties hereto, City and Contractor agree as follows:

1. The following are incorporated into this contract as though fully set forth herein:
 - (a) The attached Faithful Performance and Payment Bonds.
 - (b) The attached Proposal included in the Bid documents by the Contractor.
 - (c) Reference Standards listed in the Notice Inviting Bids and the Supplementary Special Provisions (SSP).
 - (d) That certain documents entitled **Trail For All People**, on file in the office of the Public Works Department as Document No. **S-13001**, as well as all matters referenced therein.
2. The Contractor shall perform and be bound by all the terms and conditions of this contract and in strict conformity therewith shall perform and complete in a good and workmanlike manner **Trail For All People**, Bid No. **L-16-1240-DBB-1**, San Diego, California.
3. For such performances, the City shall pay to Contractor the amounts set forth at the times and in the manner and with such additions or deductions as are provided for in this contract, and the Contractor shall accept such payment in full satisfaction of all claims incident to such performances.
4. No claim or suit whatsoever shall be made or brought by Contractor against any officer, agent, or employee of the City for or on account of anything done or omitted to be done in connection with this contract, nor shall any such officer, agent, or employee be liable hereunder.
5. This contract is effective as of the date that the Mayor or designee signs the agreement.

CONTRACT FORMS (continued)

IN WITNESS WHEREOF, this Agreement is signed by the City of San Diego, acting by and through its Mayor or designee, pursuant to **Municipal Code 22.3102** authorizing such execution.

THE CITY OF SAN DIEGO

APPROVED AS TO FORM

By 

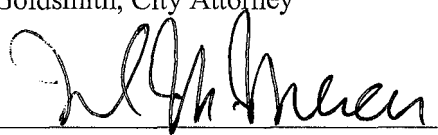
Jan I. Goldsmith, City Attorney
By 

Print Name: Stephen Samara,
Principal Contract Specialist

Print Name: Mark H. Plever
Deputy City Attorney

Date: 10/30/15

Date: 10/30/15

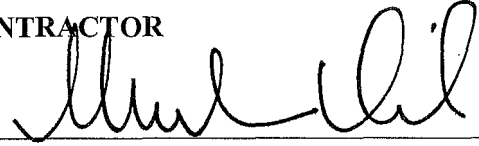
CONTRACTOR
By 

Print Name: S. ELIHU

Title: OWNER

Date: 9/22/15

City of San Diego License No.: BZ010019612

State Contractor's License No.: 824455

**CONTRACT FORMS
ATTACHMENTS**

EXECUTED IN TRIPLICATE
BOND NO. 2200138
PREMIUM: \$4,578.00
PREMIUM IS FOR CONTRACT TERM
AND IS SUBJECT TO ADJUSTMENT
BASED ON FINAL CONTRACT PRICE

CONTRACT FORMS ATTACHMENTS
PERFORMANCE BOND AND LABOR AND MATERIALMEN'S BOND

FAITHFUL PERFORMANCE BOND AND LABOR AND MATERIALMEN'S BOND:

BLUE PACIFIC ENGINEERING & CONSTRUCTION _____, a corporation, as principal, and
NORTH AMERICAN SPECIALTY INSURANCE COMPANY _____, a corporation authorized to do
business in the State of California, as Surety, hereby obligate themselves, their successors and
assigns, jointly and severally, to The City of San Diego a municipal corporation in the sum of
TWO HUNDRED THIRTY EIGHT THOUSAND FIVE HUNDRED AND 00/100 DOLLARS(\$238,500.00) for the faithful performance of the
annexed contract, and in the sum of TWO HUNDRED THIRTY EIGHT THOUSAND
FIVE HUNDRED AND 00/100 DOLLARS(\$238,500.00) for the
benefit of laborers and materialmen designated below.

Conditions:

If the Principal shall faithfully perform the annexed contract **Trail For All People;**
Bid No. **L-16-1240-DBB-1**, San Diego, California then the obligation herein with respect to a faithful
performance shall be void; otherwise it shall remain in full force.

If the Principal shall promptly pay all persons, firms and corporations furnishing materials for
or performing labor in the execution of this contract, and shall pay all amounts due under the
California Unemployment Insurance Act then the obligation herein with respect to laborers and
materialmen shall be void; otherwise it shall remain in full force.

The obligation herein with respect to laborers and materialmen shall inure to the benefit of all
persons, firms and corporations entitled to file claims under the provisions of Chapter 3 of Division 5
of Title I of the Government Code of the State of California or under the provisions of Section 3082
et seq. of the Civil Code of the State of California.

Changes in the terms of the annexed contract or specifications accompanying same or
referred to therein shall not affect the Surety's obligation on this bond, and the Surety hereby waives
notice of same.

CONTRACT FORMS ATTACHMENTS (continued)
PERFORMANCE BOND AND LABOR AND MATERIALMEN'S BOND

The Surety shall pay reasonable attorney's fees should suit be brought to enforce the provisions of this bond.

Dated SEPTEMBER 16, 2015

Approved as to Form

BLUE PACIFIC ENGINEERING & CONSTRUCTION

Principal

By 

S. ELIHU

Printed Name of Person Signing for Principal

Jan I. Goldsmith, City Attorney

By 

Deputy City Attorney

NORTH AMERICAN SPECIALTY INSURANCE COMPANY

Surety

By 

Attorney-in-fact

Approved:

By 

Mayor or Designee

6 HUTTON CENTRE DRIVE, SUITE 850

Local Address of Surety

SANTA ANA, CA 92707

Local Address (City, State) of Surety

714/550-7799

Local Telephone No. of Surety

PREMIUM IS FOR CONTRACT TERM
AND IS SUBJECT TO ADJUSTMENT
BASED ON FINAL CONTRACT PRICE

Premium \$ 4,578.00

Bond No. 2200138

CALIFORNIA ALL-PURPOSE ACKNOWLEDGMENT

CIVIL CODE § 1189

A notary public or other officer completing this certificate verifies only the identity of the individual who signed the document to which this certificate is attached, and not the truthfulness, accuracy, or validity of that document.

State of California)
County of SAN DIEGO)

On 9/16/2015 before me, MICHELLE M. BASUIL, NOTARY PUBLIC
Date Here Insert Name and Title of the Officer

personally appeared MARK D. IATAROLA
Name(s) of Signer(s)

who proved to me on the basis of satisfactory evidence to be the person(s) whose name(s) is/are subscribed to the within instrument and acknowledged to me that he/~~she~~/they executed the same in his/~~her~~/their authorized capacity(ies), and that by his/~~her~~/their signature(s) on the instrument the person(s), or the entity upon behalf of which the person(s) acted, executed the instrument.

I certify under PENALTY OF PERJURY under the laws of the State of California that the foregoing paragraph is true and correct.

WITNESS my hand and official seal.

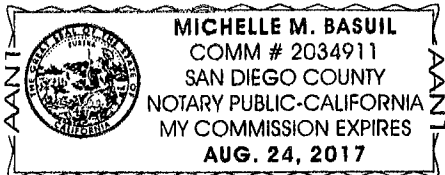

Signature *Michelle M. Basuil*
Signature of Notary Public

Place Notary Seal Above

OPTIONAL

Though this section is optional, completing this information can deter alteration of the document or fraudulent reattachment of this form to an unintended document.

Description of Attached Document

Title or Type of Document: _____ Document Date: _____

Number of Pages: _____ Signer(s) Other Than Named Above: _____

Capacity(ies) Claimed by Signer(s)

Signer's Name: MARK D. IATAROLA

Corporate Officer — Title(s): _____

Partner — Limited General

Individual Attorney in Fact

Trustee Guardian or Conservator

Other: _____

Signer Is Representing: _____

Signer's Name: _____

Corporate Officer — Title(s): _____

Partner — Limited General

Individual Attorney in Fact

Trustee Guardian or Conservator

Other: _____

Signer Is Representing: _____

NAS SURETY GROUP

NORTH AMERICAN SPECIALTY INSURANCE COMPANY
WASHINGTON INTERNATIONAL INSURANCE COMPANY

GENERAL POWER OF ATTORNEY

KNOW ALL MEN BY THESE PRESENTS, THAT North American Specialty Insurance Company, a corporation duly organized and existing under laws of the State of New Hampshire, and having its principal office in the City of Manchester, New Hampshire, and Washington International Insurance Company, a corporation organized and existing under the laws of the State of New Hampshire and having its principal office in the City of Schaumburg, Illinois, each does hereby make, constitute and appoint:

JOHN G. MALONEY, HELEN MALONEY, MICHELLE M. BASUIL,
GLEND A J. ROONEY, and MARK D. IATAROLA

JOINTLY OR SEVERALLY

Its true and lawful Attorney(s)-in-Fact, to make, execute, seal and deliver, for and on its behalf and as its act and deed, bonds or other writings obligatory in the nature of a bond on behalf of each of said Companies, as surety, on contracts of suretyship as are or may be required or permitted by law, regulation, contract or otherwise, provided that no bond or undertaking or contract or suretyship executed under this authority shall exceed the amount of:
FIFTY MILLION (\$50,000,000.00) DOLLARS

This Power of Attorney is granted and is signed by facsimile under and by the authority of the following Resolutions adopted by the Boards of Directors of both North American Specialty Insurance Company and Washington International Insurance Company at meetings duly called and held on the 9th of May, 2012:

"RESOLVED, that any two of the Presidents, any Managing Director, any Senior Vice President, any Vice President, any Assistant Vice President, the Secretary or any Assistant Secretary be, and each or any of them hereby is authorized to execute a Power of Attorney qualifying the attorney named in the given Power of Attorney to execute on behalf of the Company bonds, undertakings and all contracts of surety, and that each or any of them hereby is authorized to attest to the execution of any such Power of Attorney and to attach therein the seal of the Company; and it is

FURTHER RESOLVED, that the signature of such officers and the seal of the Company may be affixed to any such Power of Attorney or to any certificate relating thereto by facsimile, and any such Power of Attorney or certificate bearing such facsimile signatures or facsimile seal shall be binding upon the Company when so affixed and in the future with regard to any bond, undertaking or contract of surety to which it is attached."



By [Signature]
Steven P. Anderson, Senior Vice President of Washington International Insurance Company
& Senior Vice President of North American Specialty Insurance Company



By [Signature]
David M. Layman, Vice President of Washington International Insurance Company
& Vice President of North American Specialty Insurance Company

IN WITNESS WHEREOF, North American Specialty Insurance Company and Washington International Insurance Company have caused their official seals to be hereunto affixed, and these presents to be signed by their authorized officers this 9th day of May, 2014.

North American Specialty Insurance Company
Washington International Insurance Company

State of Illinois
County of Cook ss:

On this 9th day of May, 2014, before me, a Notary Public personally appeared Steven P. Anderson, Senior Vice President of Washington International Insurance Company and Senior Vice President of North American Specialty Insurance Company and David M. Layman, Vice President of Washington International Insurance Company and Vice President of North American Specialty Insurance Company, personally known to me, who being by me duly sworn, acknowledged that they signed the above Power of Attorney as officers of and acknowledged said instrument to be the voluntary act and deed of their respective companies.

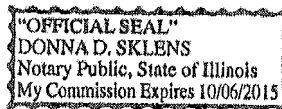

[Signature]
Donna D. Sklens, Notary Public

I, Jeffrey Goldberg, the duly elected Assistant Secretary of North American Specialty Insurance Company and Washington International Insurance Company, do hereby certify that the above and foregoing is a true and correct copy of a Power of Attorney given by said North American Specialty Insurance Company and Washington International Insurance Company, which is still in full force and effect.

IN WITNESS WHEREOF, I have set my hand and affixed the seals of the Companies this 16th day of SEPTEMBER, 2015.

[Signature]
Jeffrey Goldberg, Vice President & Assistant Secretary of
Washington International Insurance Company & North American Specialty Insurance Company

CONTRACTOR CERTIFICATION

DRUG-FREE WORKPLACE

PROJECT TITLE: Trail For All People

I hereby certify that I am familiar with the requirements of San Diego City Council Policy No. 100-17 regarding Drug-Free Workplace as outlined in the WHITEBOOK, Section 7-13.3, "Drug-Free Workplace", of the project specifications, and that;

BLUEPACIFIC ENGR.

(Name under which business is conducted)

has in place a drug-free workplace program that complies with said policy. I further certify that each subcontract agreement for this project contains language which indicates the subcontractor's agreement to abide by the provisions of subdivisions a) through c) of the policy as outlined.

Signed

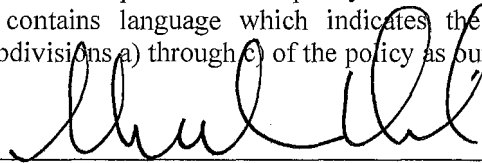

Printed Name

S. ELIHU

Title

OWNER

CONTRACTOR CERTIFICATION

AMERICAN WITH DISABILITIES ACT (ADA) COMPLIANCE CERTIFICATION

PROJECT TITLE: Trail For All People

I hereby certify that I am familiar with the requirements of San Diego City Council Policy No. 100-4 regarding the American With Disabilities Act (ADA) outlined in the WHITEBOOK, Section 7-13.2, "American With Disabilities Act", of the project specifications, and that;

BLUEPACIFIC ENGINEERING
(Name under which business is conducted)

has in place a workplace program that complies with said policy. I further certify that each subcontract agreement for this project contains language which indicates the subcontractor's agreement to abide by the provisions of the policy as outlined.

Signed

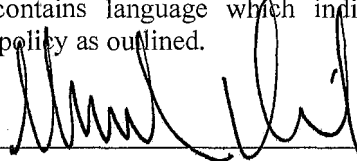

Printed Name

S. EWIFV

Title

OWNER

CONTRACTOR CERTIFICATION

CONTRACTOR STANDARDS – PLEDGE OF COMPLIANCE

PROJECT TITLE: Trail For All People

I declare under penalty of perjury that I am authorized to make this certification on behalf of _____, as Contractor, that I am familiar with the requirements of City of San Diego Municipal Code § 22.3004 regarding Contractor Standards as outlined in the WHITEBOOK, Section 7-13.4, ("Contractor Standards"), of the project specifications, and that Contractor has complied with those requirements.

I further certify that each of the Contractor's subcontractors whose subcontracts are greater than \$50,000 in value has completed a Pledge of Compliance attesting under penalty of perjury of having complied with City of San Diego Municipal Code § 22.3004.

Dated this 23 Day of SEPT., 2015.

Signed

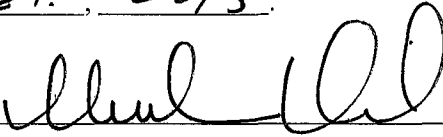

Printed Name

S. ELIHU

Title

OWNER

AFFIDAVIT OF DISPOSAL

WHEREAS, on the _____ DAY OF _____, 2____ the undersigned entered into and executed a contract with the City of San Diego, a municipal corporation, for:

Trail For All People

(Name of Project)

as particularly described in said contract and identified as Bid No. **L-16-1240-DBB-1**; SAP No. (WBS/IO/CC) **S-13001**; and **WHEREAS**, the specification of said contract requires the Contractor to affirm that "all brush, trash, debris, and surplus materials resulting from this project have been disposed of in a legal manner"; and **WHEREAS**, said contract has been completed and all surplus materials disposed of:

NOW, THEREFORE, in consideration of the final payment by the City of San Diego to said Contractor under the terms of said contract, the undersigned Contractor, does hereby affirm that all surplus materials as described in said contract have been disposed of at the following location(s)

and that they have been disposed of according to all applicable laws and regulations.

Dated this _____ DAY OF _____, _____.

Contractor
by

ATTEST:

State of _____
County of _____

On this _____ DAY OF _____, 2____, before the undersigned, a Notary Public in and for said County and State, duly commissioned and sworn, personally appeared _____ known to me to be the _____ Contractor named in the foregoing Release, and whose name is subscribed thereto, and acknowledged to me that said Contractor executed the said Release.

Notary Public in and for said County and State

ATTACHMENTS

ATTACHMENT A
SCOPE OF WORK

SCOPE OF WORK

1. **SCOPE OF WORK:** Includes but not limited to: 1100 LF stabilized DG trail with pop-outs to meet the most current access law regulations; trail head sign; accessible parking; fence; benches; shade structures; interpretive signs. The trail is generally located within the Black Mountain Open Space Park.

1.1. The Work shall be performed in accordance with:

1.1.1. The Notice Inviting Bids and Plans numbered **37860-1-D** through **37860-7-D**, inclusive.

2. **CONSTRUCTION COST:** The City's estimated construction cost for this contract is **\$250,000.00**.

3. **LOCATION OF WORK: The location of the Work is as follows:**

See Appendix "E", Location Map.

4. **CONTRACT TIME:** The Contract Time for the completion of the Work, excluding the Plant Establishment Period (PEP), shall be **88 Working Days**. The Contractor shall have an additional 98 Working Days to complete the PEP work and shall begin the PEP after all the other Work, has been completed. Liquidated Damages shall apply for not completing the Work, excluding the PEP, within 88 Working Days and not completing the PEP within 98 Working Days.

5. **CONTRACTOR'S LICENSE CLASSIFICATION:** In accordance with the provisions of California Law, the Contractor shall possess valid appropriate license(s) at the time that the Bid is submitted. Failure to possess the specified license(s) shall render the Bid as **non-responsive** and shall act as a bar to award of the Contract to any Bidder not possessing required license(s) at the time of Bid.

5.1. The City has determined the following licensing classification for this contract:

- CLASS A

ATTACHMENT B
INTENTIONALLY LEFT BLANK

ATTACHMENT C
EQUAL OPPORTUNITY CONTRACTING PROGRAM

EQUAL OPPORTUNITY CONTRACTING PROGRAM

1. To The WHITEBOOK, Chapter 10, Sections D and E, DELETE each in its entirety, and SUBSTITUTE with the following:

D. CITY'S EQUAL OPPORTUNITY COMMITMENT.

1. Nondiscrimination in Contracting Ordinance.

1. The Contractor, Subcontractors and Suppliers shall comply with requirements of the City's Nondiscrimination in Contracting Ordinance, San Diego Municipal Code §§22.3501 through 22.3517.

The Contractor shall not discriminate on the basis of race, gender, religion, national origin, ethnicity, sexual orientation, age, or disability in the solicitation, selection, hiring, or treatment of subcontractors, vendors, or suppliers. The Contractor shall provide equal opportunity for subcontractors to participate in subcontracting opportunities. The Contractor understands and agrees that violation of this clause shall be considered a material breach of the contract and may result in contract termination, debarment, or other sanctions.

The Contractor shall include the foregoing clause in all contracts between the Contractor and Subcontractors and Suppliers.

2. Disclosure of Discrimination Complaints. As part of its Bid or Proposal, the Bidder shall provide to the City a list of all instances within the past 10 years where a complaint was filed or pending against Bidder in a legal or administrative proceeding alleging that Bidder discriminated against its employees, subcontractors, vendors, or suppliers, and a description of the status or resolution of that complaint, including any remedial action taken.
3. Upon the City's request, the Contractor agrees to provide to the City, within 60 days, a truthful and complete list of the names of all Subcontractors and Suppliers that the Contractor has used in the past 5 years on any of its contracts that were undertaken within San Diego County, including the total dollar amount paid by the Contractor for each subcontract or supply contract.
4. The Contractor further agrees to fully cooperate in any investigation conducted by the City pursuant to the City's Nondiscrimination in Contracting Ordinance, Municipal Code §§22.3501 through 22.3517. The Contractor understands and agrees that violation of this clause shall be considered a material breach of the Contract and may result in remedies being ordered against the Contractor up to and including contract termination, debarment and other sanctions for violation of the provisions of the Nondiscrimination in Contracting Ordinance. The Contractor further understands and agrees that the procedures, remedies and sanctions provided for in the Nondiscrimination in Contracting Ordinance apply only to violations of the Ordinance.

E. EQUAL EMPLOYMENT OPPORTUNITY OUTREACH PROGRAM.

1. The Contractor, Subcontractors and Suppliers shall comply with the City's Equal Employment Opportunity Outreach Program, San Diego Municipal Code §§22.2701 through 22.2707.

The Contractor shall not discriminate against any employee or applicant for employment on any basis prohibited by law. Contractor shall provide equal opportunity in all employment practices. Prime Contractor shall ensure their subcontractors comply with this program. Nothing in this section shall be interpreted to hold a prime contractor liable for any discriminatory practice of its subcontractors.

The Contractor shall include the foregoing clause in all contracts between the Contractor and Subcontractors and Suppliers.

2. If the Contract is competitively solicited, the selected Bidder shall submit a Work Force Report (Form BB05), within 10 Working Days after receipt by the Bidder of Contract forms to the City for approval as specified in the Notice of Intent to Award letter from the City.
3. If a Work Force Report is submitted, and the City determines there are under-representations when compared to County Labor Force Availability data, the selected Bidder shall submit an Equal Employment Opportunity Plan.
4. If the selected Bidder submits an Equal Employment Opportunity Plan, it shall include the following assurances:
 1. The Contractor shall maintain a working environment free of discrimination, harassment, intimidation and coercion at all sites and in all facilities at which the Contractor's employees are assigned to work.
 2. The Contractor reviews its EEO Policy, at least annually, with all on-site supervisors involved in employment decisions.
 3. The Contractor disseminates and reviews its EEO Policy with all employees at least once a year, posts the policy statement and EEO posters on all company bulletin boards and job sites, and documents every dissemination, review and posting with a written record to identify the time, place, employees present, subject matter, and disposition of meetings.
 4. The Contractor reviews, at least annually, all supervisors' adherence to and performance under the EEO Policy and maintains written documentation of these reviews.
 5. The Contractor discusses its EEO Policy Statement with subcontractors with whom it anticipates doing business, includes the EEO Policy Statement in its subcontracts, and provides such documentation to the City upon request.

6. The Contractor documents and maintains a record of all bid solicitations and outreach efforts to and from subcontractors, contractor associations and other business associations.
7. The Contractor disseminates its EEO Policy externally through various media, including the media of people of color and women, in advertisements to recruit, maintains files documenting these efforts, and provides copies of these advertisements to the City upon request.
8. The Contractor disseminates its EEO Policy to union and community organizations.
9. The Contractor provides immediate written notification to the City when any union referral process has impeded the Contractor's efforts to maintain its EEO Policy.
10. The Contractor maintains a current list of recruitment sources, including those outreaching to people of color and women, and provides written notification of employment opportunities to these recruitment sources with a record of the organizations' responses.
11. The Contractor maintains a current file of names, addresses and phone numbers of each walk-in applicant, including people of color and women, and referrals from unions, recruitment sources, or community organizations with a description of the employment action taken.
12. The Contractor encourages all present employees, including people of color and women employees, to recruit others.
13. The Contractor maintains all employment selection process information with records of all tests and other selection criteria.
14. The Contractor develops and maintains documentation for on-the-job training opportunities, participates in training programs, or both for all of its employees, including people of color and women, and establishes apprenticeship, trainee, and upgrade programs relevant to the Contractor's employment needs.
15. The Contractor conducts, at least annually, an inventory and evaluation of all employees for promotional opportunities and encourages all employees to seek and prepare appropriately for such opportunities.
16. The Contractor ensures the company's working environment and activities are non-segregated except for providing separate or single-user toilets and necessary changing facilities to assure privacy between the sexes.

ATTACHMENT D
INTENTIONALLY LEFT BLANK

ATTACHMENT E
SUPPLEMENTARY SPECIAL PROVISIONS

SUPPLEMENTARY SPECIAL PROVISIONS

The following Supplementary Special Provisions (SSP) modifies the following documents:

- 1) Standard Specifications for Public Works Construction (The GREENBOOK) currently in effect.
 - 2) The City of San Diego Standard Specifications for Public Works Construction (The WHITEBOOK).
-

SECTION 1 – TERMS, DEFINITIONS, ABBREVIATIONS, UNITS OF MEASURE, AND SYMBOLS

1-2 TERMS AND DEFINITIONS.

Normal Working Hours. To the City Supplement, ADD the following:

The Normal Working Hours are **7:00 AM to 3:30 PM.**

SECTION 2 - SCOPE AND CONTROL OF WORK

2-3.2 Self Performance. DELETE in its entirety and SUBSTITUTE with the following:

1. You must perform, with your own organization, Contract work amounting to at least 50% of the base bid alone or base bid and any additive or deductive alternate(s) that together when added or deducted form the basis of award.

2-5.3.1 General. To the City Supplement, ADD the following

7. For products for which an AML is available, products listed in the AML shall be used. A submittal review will be conducted for products not identified on an AML on a case-by-case basis when:
 - a) The product type or category is not in the AML.
 - b) The AML does not list at least two available manufacturers of the product.
 - c) The material or manufacturer listed in the AML is no longer available. Documentation to substantiate the product is no longer available or in production is required as part of the submittal.

In the case of conducting a submittal review when required by the Plans or Special Provisions, or when requested by the Engineer, all submittals shall be accompanied by the City's submittal form.

The Product Submittal Form is available for download at:

<http://www.sandiego.gov/publicworks/edocref/index.shtml>

2-9.1 Permanent Survey Markers. To the City Supplement, DELETE in its entirety and SUBSTITUTE with the following:

Pursuant to Division 3, Chapter 15 of the Business and Professions Code, the Contractor shall not disturb survey monuments that “control the location of subdivisions, tracts, boundaries, roads, streets, or highways, or provide horizontal or vertical survey control” until they have been tied out by a Registered Land Surveyor or Registered Civil Engineer authorized to practice land surveying within the State of California.

Monument Preservation will be performed by City Public Works Field Engineering Division (PW-FED) Field Survey Section on all Projects, unless permission is obtained for these services in writing by PW-FED.

The Contractor shall submit to the Engineer a minimum of 7 Days prior to the start of the Work a list of controlling survey monuments which may be disturbed. The Agency (or the owner on a Private Contract) will:

- a) set survey points outside the affected work area that reference and locate each controlling survey monument that may be disturbed,
- b) file a Corner Record or Record of Survey with the County Surveyor after setting the survey points to be used for re-establishment of the disturbed controlling survey monuments, and
- a) file a Corner Record of Record of Survey with the County Surveyor after re-establishment of the disturbed controlling survey monuments.

SECTION 4 - CONTROL OF MATERIALS

4-1.3.6 Preapproved Materials. To the City Supplement, ADD the following:

3. You shall submit in writing a list of all products to be incorporated in the Work that are on the AML.

4-1.6 Trade Names or Equals. ADD the following:

You must submit your list of proposed substitutions for “an equal” (“or equal”) item(s) **no later than 5 Working Days after the determination of the Apparent Low Bidder** and on the City’s Product Submittal Form available at:

<http://www.sandiego.gov/publicworks/edocref/index.shtml>

SECTION 6 - PROSECUTION, PROGRESS AND ACCEPTANCE OF WORK

6-1.1 Construction Schedule. To item 20, ADD the following:

The 120 Calendar Day for the Plant Establishment Period is included in the stipulated Contract Time.

SECTION 7 - RESPONSIBILITIES OF THE CONTRACTOR

7-3 **LIABILITY INSURANCE.** DELETE in its entirety and SUBSTITUTE with the following:

The insurance provisions herein must not be construed to limit your indemnity obligations contained in the Contract.

7-3.1 **Policies and Procedures.**

1. You must procure the insurance described below, at its sole cost and expense, to provide coverage against claims for loss including injuries to persons or damage to property, which may arise out of or in connection with the performance of the Work by you, your agents, representatives, officers, employees or Subcontractors.
2. Insurance coverage for property damage resulting from your operations is on a replacement cost valuation. The market value will not be accepted.
3. You must maintain this insurance for the duration of this contract and at all times thereafter when you are correcting, removing, or replacing Work in accordance with this contract. Your liabilities under the Contract, e.g., your indemnity obligations, is not deemed limited to the insurance coverage required by this contract.
4. Payment for insurance is included in the various items of Work as bid by you, and except as specifically agreed to by the City in writing, you are not entitled to any additional payment. Do not begin any work under this contract until you have provided and the City has approved all required insurance.
5. Policies of insurance must provide that the City is entitled to 30 days (10 days for cancellation due to non-payment of premium) prior written notice of cancellation or non-renewal of the policy. Maintenance of specified insurance coverage is a material element of the Contract. Your failure to maintain or renew coverage or to provide evidence of renewal during the term of the Contract may be treated by the City as a material breach of the Contract.

7-3.2 **Types of Insurance.**

7-3.2.1 **Commercial General Liability Insurance.**

1. Commercial General Liability Insurance must be written on the current version of the ISO Occurrence form CG 00 01 07 98 or an equivalent form providing coverage at least as broad.
2. The policy must cover liability arising from premises and operations, XCU (explosions, underground, and collapse), independent contractors, products/completed operations, personal injury and advertising injury, bodily injury, property damage, and liability assumed under an insured's contract (including the tort liability of another assumed in a business contract).

3. There must be no endorsement or modification limiting the scope of coverage for either “insured vs. insured” claims or contractual liability. You must maintain the same or equivalent insurance for at least 10 years following completion of the Work.
4. All costs of defense must be outside the policy limits. Policy coverage must be in liability limits of not less than the following:

<u>General Annual Aggregate Limit</u>	<u>Limits of Liability</u>
Other than Products/Completed Operations	\$2,000,000
Products/Completed Operations Aggregate Limit	\$2,000,000
Personal Injury Limit	\$1,000,000
Each Occurrence	\$1,000,000

7-3.2.2 Commercial Automobile Liability Insurance.

1. You must provide a policy or policies of Commercial Automobile Liability Insurance written on the current version of the ISO form CA 00 01 12 90 or later version or equivalent form providing coverage at least as broad in the amount of \$1,000,000 combined single limit per accident, covering bodily injury and property damage for owned, non-owned, and hired automobiles (“Any Auto”).
2. All costs of defense must be outside the limits of the policy.

7-3.3 Rating Requirements. Except for the State Compensation Insurance Fund, all insurance required by this contract as described herein must be carried only by responsible insurance companies with a rating of, or equivalent to, at least “A-, VI” by A.M. Best Company, that are authorized by the California Insurance Commissioner to do business in the State, and that have been approved by the City.

7-3.3.1 Non-Admitted Carriers. The City will accept insurance provided by non-admitted, “surplus lines” carriers only if the carrier is authorized to do business in the State and is included on the List of Approved Surplus Lines Insurers (LASLI list).

All policies of insurance carried by non-admitted carriers must be subject to all of the requirements for policies of insurance provided by admitted carriers described herein.

7-3.4 Evidence of Insurance. Furnish to the City documents e.g., certificates of insurance and endorsements evidencing the insurance required herein, and furnish renewal documentation prior to expiration of this insurance. Each required document must be signed by the insurer or a person authorized by the insurer to bind coverage on its behalf. We reserve the right to require complete, certified copies of all insurance policies required herein.

7-3.5 Policy Endorsements.

7-3.5.1 Commercial General Liability Insurance.

7-3.5.1.1 Additional Insured.

- a) You must provide at your expense policy endorsement written on the current version of the ISO Occurrence form CG 20 10 11 85 or an equivalent form providing coverage at least as broad.
- b) To the fullest extent allowed by law e.g., California Insurance Code §11580.04, the policy must be endorsed to include the City and its respective elected officials, officers, employees, agents, and representatives as additional insured.
- c) The additional insured coverage for projects for which the Engineer's Estimate is \$1,000,000 or more must include liability arising out of: (a) Ongoing operations performed by you or on your behalf, (b) your products, (c) your work, e.g., your completed operations performed by you or on your behalf, or (d) premises owned, leased, controlled, or used by you.
- d) The additional insured coverage for projects for which the Engineer's Estimate is less than \$1,000,000 must include liability arising out of: (a) Ongoing operations performed by you or on your behalf, (b) your products, or (c) premises owned, leased, controlled, or used by you.

7-3.5.1.2 Primary and Non-Contributory Coverage. The policy must be endorsed to provide that the coverage with respect to operations, including the completed operations, if appropriate, of the Named Insured is primary to any insurance or self-insurance of the City and its elected officials, officers, employees, agents and representatives. Further, it must provide that any insurance maintained by the City and its elected officials, officers, employees, agents and representatives must be in excess of your insurance and must not contribute to it.

7-3.5.1.3 Project General Aggregate Limit. The policy or policies must be endorsed to provide a Designated Construction Project General Aggregate Limit that will apply only to the Work. Only claims payments which arise from the Work must reduce the Designated Construction Project General Aggregate Limit. The Designated Construction Project General Aggregate Limit must be in addition to the aggregate limit provided for the products-completed operations hazard.

7-3.5.2 Commercial Automobile Liability Insurance.

7-3.5.2.1 Additional Insured. Unless the policy or policies of Commercial Auto Liability Insurance are written on an ISO form CA 00 01 12 90 or a later version of this form or equivalent form providing coverage at least as broad, the policy must be endorsed to include the City and its respective elected officials, officers, employees, agents, and representatives as additional insured, with respect to liability arising out of automobiles owned, leased, hired or borrowed by you or on your behalf. This endorsement is limited to the obligations permitted by California Insurance Code §11580.04.

7-3.6 Deductibles and Self-Insured Retentions. You must pay for all deductibles and self-insured retentions. You must disclose deductibles and self-insured retentions to the City at the time the evidence of insurance is provided.

7-3.7 Reservation of Rights. The City reserves the right, from time to time, to review your insurance coverage, limits, deductibles and self-insured retentions to determine if they are acceptable to the City. The City will reimburse you, without overhead,

profit, or any other markup, for the cost of additional premium for any coverage requested by the Engineer but not required by this contract.

7-3.8 Notice of Changes to Insurance. You must notify the City 30 days prior to any material change to the policies of insurance provided under this contract.

7-3.9 Excess Insurance. Policies providing excess coverage must follow the form of the primary policy or policies e.g., all endorsements.

7-4 WORKERS' COMPENSATION INSURANCE. DELETE in its entirety and SUBSTITUTE with the following:

7-4.1 Workers' Compensation Insurance and Employers Liability Insurance.

1. In accordance with the provisions of §3700 of the California Labor Code, you must provide at your expense Workers' Compensation Insurance and Employers Liability Insurance to protect you against all claims under applicable state workers compensation laws. The City, its elected officials, and employees will not be responsible for any claims in law or equity occasioned by your failure to comply with the requirements of this section.

2. Limits for this insurance must be not less than the following:

<u>Workers' Compensation</u>	<u>Statutory Employers Liability</u>
Bodily Injury by Accident	\$1,000,000 each accident
Bodily Injury by Disease	\$1,000,000 each employee
Bodily Injury by Disease	\$1,000,000 policy limit

3. By signing and returning the Contract you certify that you are aware of the provisions of §3700 of the Labor Code which require every employer to be insured against liability for worker's compensation or to undertake self-insurance in accordance with the provisions of that code and you must comply with such provisions before commencing the Work as required by §1861 of the California Labor Code.

7-4.1.1 Waiver of Subrogation. The policy or policies must be endorsed to provide that the insurer will waive all rights of subrogation against the City, and its respective elected officials, officers, employees, agents, and representatives for losses paid under the terms of the policy or policies and which arise from work performed by the Named Insured for the City.

7-15 INDEMNIFICATION AND HOLD HARMLESS AGREEMENT. To the City Supplement, fourth paragraph, last sentence, DELETE in its entirety and SUBSTITUTE with the following:

Your duty to indemnify and hold harmless does not include any claims or liability arising from the established active or sole negligence, or willful misconduct of the City, its officers, or employees.

7-20 **ELECTRONIC COMMUNICATION.** ADD the following:

Virtual Project Manager will be used on this contract.

SECTION 9 - MEASUREMENT AND PAYMENT

9-3.2.5 **Withholding of Payment.** To the City Supplement, item i), DELETE in its entirety and SUBSTITUTE with the following:

- i) Your failure to comply with 7-2.3, "PAYROLL RECORDS" and 2-16, "CONTRACTOR REGISTRATION AND ELECTRONIC REPORTING SYSTEM."

ADD:

9-3.7 **Compensation Adjustments for Price Index Fluctuations.** This Contract is not subject to the provisions of The WHITEBOOK for Compensation Adjustments for Price Index Fluctuations for the paving asphalt.

SECTION 203 – BITUMINOUS MATERIALS

203-15 **RUBBER POLYMER MODIFIED SLURRY (RPMS).** To the City Supplement, CORRECT section numbering as follows:

OLD SECTION NUMBER	TITLE	NEW SECTION NUMBER
203-15	RUBBER POLYMER MODIFIED SLURRY (RPMS)	203-16
203-15.1	General	203-16.1
203-15.2	Materials	203-16.2
203-15.3	Composition and Grading	203-16.3
203-15.4	Mix Design	203-16.4

ADD the following:

RPMS shall be used on this contract.

SECTION 212 - LANDSCAPE AND IRRIGATION MATERIALS

ADD:

212-3.2.2.3 **Trench Marker Tape.** To the City Supplement, DELETE in its entirety and SUBSTITUTE with the following:

- a) Trench marker tape shall be 6" wide and consist of a minimum 5.0 mil, five-ply 100% virgin polyethylene which is acid, alkaline and corrosion resistant. Elongation properties and tensile strength of not less than 7,800 psi shall be

in accordance with ASTM D882-80A. The trench marker tape for water lines shall have a minimum 20 gauge solid aluminum foil core, adhered to a 2.55 mil polyethylene backing.

- b) Tape color and legend shall be placed beneath the top protective layer subject to the following:
1. Blue with "Caution Potable Water Line Buried Below" for Water mainlines and over pipe sleeves.
 2. Purple with "Caution Recycled/Reclaimed Water Line Buried Below" for recycled water irrigation mainlines.
 3. Red with "Caution Electric Line Buried Below" for electrical lines servicing the irrigation system, including, but not limited to, 110/220v power to irrigation controllers and pumps, communication cables and irrigation direct burial control wires to remote control valves.
 4. Green with "Caution Sewer Line Buried Below" for Sewer mainlines and over pipe sleeves.

SECTION 300 – EARTHWORK

300-1.4 **Payment.** To the City Supplement, paragraph (2), DELETE in its entirety and SUBSTITUTE with the following:

2. Payment for existing pavement removal and disposal of up to 12" thick, within the excavation e.g., trench limits, shall be included in the Bid item for the Work item that requires pavement removal.

SECTION 302 – ROADWAY SURFACING

302-3 **PREPARATORY REPAIR WORK.** To the City Supplement, DELETE in its entirety and SUBSTITUTE with the following:

302-3 **PREPARATORY REPAIR WORK FOR PARKING AND TRAIL SURFACING.**

1. Prior to accessible parking resurfacing or the application of slurry, the Contractor shall complete all necessary preparation and repair work to the area of work shown on the drawings e.g., crack sealing, asphalt repair, hump removal, miscellaneous asphalt patching, removal of raised pavement markers, removal of pavement markings, etc. and as specified in the Special Provisions.
2. Preparatory work for the trail shall include, but not be limited to, tree trimming, weed removal, weed abatement, and removal of rocks larger than 3". Subgrade for the Trail shall be compacted to 90%, or as directed by the Resident Engineer.

3. The Contractor shall repair areas of distressed asphalt concrete pavement within the area of work shown on the drawings by milling or removing damaged areas of pavement to a minimum depth of 3" to expose firm and unyielding pavement. The Contractor shall prepare subgrade as needed and install a minimum of 3" of compacted asphalt concrete pavement over compacted native material as directed by the Resident Engineer.
4. If, in order to achieve the minimum specified depth, the base material is exposed, the material shall be compacted to 95% relative compaction to a depth 10" below the finished grade (dig out). Compaction tests shall be made to ensure compliance with the specifications. The Resident Engineer will determine when and where the test will occur. The City will pay for the soils testing required by the Resident Engineer, which meets the required compaction. The Contractor shall reimburse the City for the cost of retesting failing compaction tests. If additional base material is required, the Contractor shall use Class 2 Aggregate Base in accordance with 200-2.2, "Crushed Aggregate Base."
5. Prior to replacing asphalt in the accessible parking area shown on the drawings, the area shall be cleaned by removing all loose and damaged material, moisture, dirt, and other foreign matter and shall be tack coated in accordance with 302-5.4 "Tack Coat."
6. The Contractor shall install new asphalt within the accessible parking area shown on the drawings in accordance with 302-5, "ASPHALT CONCRETE PAVEMENT." Asphalt concrete shall be C2-PG 64-10 in compliance with 400-4, "ASPHALT CONCRETE."
7. No preparatory asphalt work shall be done when the atmospheric temperature is below 50 °F or during unsuitable weather.
8. Following the asphalt placement, the Contractor shall roll the entire area of new asphalt in both directions at least twice. The finished patch shall be level and smooth in compliance with 302-5.6.2 "Density and Smoothness." After placement and compaction of the asphalt patch, the Contractor shall seal all finished edges with a 4" wide continuous band of SS-1H.
9. The minimum dimension for each individual repair shall be 4' x 4' and shall be subject to the following conditions:
 - a) If the base material is exposed to achieve the required minimum removal thickness, the base material shall be prepared conforming to 301-1, "SUBGRADE PREPARATION."
 - b) The Contractor may use grinding as a method for matching existing asphalt with the replaced asphalt of the accessible parking area shown on the drawings. All area of disturbance shall receive a slurry seal, in accordance with the Resident Engineer, to achieve a smooth uniform surface.

302-3.2 Payment.

1. Payment for replacement of existing pavement when required shall be included in the unit bid price for Asphalt Pavement repair for the total area replaced and no additional payment shall be made regardless of the number of replacements completed. No payment for pavement replacement will be made when the damage is due to the Contractor's failure to protect existing improvements. The Contractor shall reimburse the City for the cost of retesting all failing compaction tests.
2. Preparatory repair work and tack coating shall be included in the Bid Item for the "Construction of Trail for All People". No payment shall be made for areas of over excavation unless previously approved by the Resident Engineer.
3. Milling shall be included in the Bid item for "Construction of Trail for All People" for asphalt transition areas around the accessible parking.

302-5.1.1 Damaged AC Pavement Replacement. To the City Supplement, DELETE in its entirety.

302-5.1.2 Measurement and Payment. To the City Supplement, DELETE in its entirety.

302-5.2.1 Measurement and Payment. To the City Supplement, item c), ADD the following:
Imported Subgrade material shall be paid per bid item "Imported Backfill".

SECTION 308 – LANDSCAPE AND IRRIGATION INSTALLATION

308-7 GUARANTEE. To the City Supplement, DELETE in its entirety.

308-7 PAYMENT. ADD the following:

Work related to tree maintenance shall be included in the Bid items as follows:

- Tree Trimming (EA)
- Root Pruning (EA)
- Root Barrier (EA)

308-8 PAYMENT. To the City Supplement, DELETE in its entirety.

SECTION 700 – EXTENDED REVEGETATION, MAINTENANCE, AND MONITORING

700-1.3 Protection of Biological Resources. To the City Supplement, item 4, DELETE in its entirety and SUBSTITUTE with the following:

4. Anticipate delays if work will occur during the breeding season (March 1 – August 15) of the Coastal California Gnatcatcher. The contractor shall comply with the MMRP requirements for breeding season restrictions

including suspension of work, if deemed necessary by the Project Biologist. The City shall not be liable for delay damages due to compliance with the MMRP restrictions. Construction delays resulting from breeding season restrictions shall not be counted as Contract days.

700-1.7.2 Project Biologist. To the City Supplement, ADD the following:

For Revegetation:

The Contractor shall retain a qualified Biologist to monitor the revegetation of all disturbed areas that are seeded monthly throughout the 120 calendar days PEP (Plant Establishment Period). The Biologist shall submit a short report of site conditions, including germination, coverage, condition of BMP's (Best Management Practice) and compliance with the MMRP (Mitigation, Monitoring, & Reporting Program) . The biologist shall be at the site while the Contractor applies the seed and shall perform monthly monitoring during the PEP.

For Construction Monitoring:

The Contractor shall retain a qualified Biologist to provide monitoring during construction in compliance with the MMRP. If construction occurs between March 1 and August 15, appropriate surveys and reporting will be required in accordance with the MMRP.

SECTION 707 – RESOURCE DISCOVERIES

ADD:

707-1.1 Environmental Document. The City of San Diego Environmental Analysis Section (EAS) of the Development Services Department has prepared a **Final Mitigated Negative Declaration and Site Development Permit for Trail For All People**, as referenced in the Contract Appendix. You must comply with all requirements of the **Final Mitigated Negative Declaration and Site Development Permit** as set forth in the Contract Appendix A.

Compliance with the City's environmental document is included in the various Bid items, unless a bid item has been provided.

END OF SUPPLEMENTARY SPECIAL PROVISIONS (SSP)

TECHNICALS

TECHNICALS

TABLE OF CONTENTS

DECOMPOSED GRANITE (DG) SURFACING	Page 48 through 51
BENCH SPECIFICATION CUT SHEET	Page 52
CUSTOM HIGH PRESSURE LAMINATE SPECIFICATION	Page 53 through 58
VIENNA MODEL SHADE STRUCTURE SPECIFICATION	Page 59 through 68
MARANA MODEL SHADE STRUCTURE SPECIFICATION	Page 69 through 77

SPECIFICATION – DECOMPOSED GRANITE (DG) SURFACING

PART 1 - GENERAL

1.1 SUMMARY

- A. This Section includes material and labor requirements for construction with Decomposed Granite with Stabilizer binder additive for the following items:

1. Stabilized aggregate pathways

1.2 PERFORMANCE REQUIREMENTS

- A. Perform gradation of decomposed granite material in accordance with ASTM C 136 – Method for Sieve Analysis for Fine and Course.

1.3 SUBMITTALS

- A. Products Data: For each product specified.
- B. Submit one 5 lb. sample Decomposed Granite in a sealed plastic bag for approval by Resident Engineer. Sample shall be typical of the lot of material to be delivered and installed on the site; provide an accurate indication of color, texture, and makeup of the material.
- C. Submit one 5 lb. sample in a sealed plastic bag to Stabilizer Solutions, Inc., or approved equal, for sieve analysis for grading of decomposed granite, prior to any construction – (recommendation to allow 2 week minimum turnaround). Submit information for approval by Resident Engineer.
- D. Stabilizer: Also provide Material Safety Data Sheet (MSDS).

1.4 PROJECT / SITE CONDITIONS

- A. Field Measurements: Each bidder is required to visit the site of the Work to verify the existing conditions. No adjustments will be made to the Contract Sum for variations in the existing conditions.
1. Where surfacing is indicated to fit with other construction, verify dimensions of other construction by field measurements before proceeding with the work.
- B. Environmental Limitations: Do not install decomposed granite during rainy conditions or below 40 degrees Fahrenheit and falling.

1.5 QUALITY ASSURANCE

- A. Installer Qualifications: Installer to provide evidence to indicate successful experience in providing decomposed granite surfacing containing Stabilizer binder additive

- B. Mock-ups: Install 4 ft. wide x 10 ft. long mock-up of decomposed granite surfacing with Stabilizer additive at location as directed by Resident Engineer. Mock-up section is to be tested with a rotational penetrometer, or equal (approved by the Resident Engineer) to measure surface firmness and stability. The surface shall not displace vertically or horizontally by more than 1/2”.

1.6 WARRANTY

- A. General Warranty: The special warranty specified in this Article shall not deprive the Owner of other rights the Owner may have under other provisions of the Contract Documents and shall be in addition to, and run concurrent with, other warranties made by the Contractor under requirements of the Contract Documents.
- B. Special Warranty: Submit a written warranty executed by the installer agreeing to repair or replace components of stabilized surfacing that fail in materials or workmanship within the specified warranty period. Failures include, but are not limited to, the following:
- 1 Premature wear and tear, provided that the material is maintained in accordance with manufacturer’s written maintenance instructions.
 - 2 Failure of system to meet performance requirements.
- C. Warranty Period: Contractor shall provide warranty for performance of product. Contractor shall warranty installation of product for the time of one year from completion.

PART 2 - PRODUCTS

2.1 MANUFACTURERS

- A. Decomposed Granite and Stabilizer for crushed stone surfaces provided by the following manufacturers:
- 1 Tri-State Materials, 31885 Winchester Road, Winchester, CA 92596, (951) 840-8275, website: www.tristatematerials.com;
 - 2 Southwest Boulder & Stone, 5002 2nd. Street, Fallbrook, California 92028, (760) 4513333, website www.southwestboulder.com;
 - 3 KRC Rock Inc., 700 N. Twin Oaks Valley Road, San Marcos, CA 92069; phone (760) 744-1036, website www.krcrock.com;
 - 4 Or approved equal.

2.2 MATERIALS

- A. Decomposed Granite:

- 1 "Autumn Gold" or "Desert Sand" – Available through Southwest Boulder & Stone;
- 2 "Baja Brown" – Available through KRC Rock Inc.;
- 3 Or approved equal.

B. Composition and Size:

- 1 Granitic in origin.
- 2 Three-eighths inch (3/8") and minus.

C. Stabilizer (Stabilized Binder):

1. Patented, non-toxic, organic binder that is a colorless and odorless concentrated powder that binds decomposed granite.

2.3 EXCESS MATERIALS

- A. Provide Owner with the following excess materials for use in future decomposed granite surfacing repair: Six 40 to 50 lb. bags of the aggregate surfacing blended with proper amount of Stabilizer.

PART 3 - EXECUTION

3.1 BLENDING STABILIZER

- A. Blend 12 to 16 lbs as per manufacturer's recommendations of Stabilizer per 1-ton of decomposed granite. It is critical that Stabilizer be thoroughly and uniformly mixed throughout decomposed granite. Stabilizer shall be mechanically pre-mixed per manufacturer's recommendations using an approved mechanical blending unit that will adequately mix and blend stabilizer with aggregate. Bucket blending is not acceptable. Blending with a rake and or shovel is not acceptable.

3.2 PLACEMENT

- A. After pre-blending, place the Stabilized decomposed aggregate on prepared sub-grade, as per plans and details. Level to specified grade and cross section.
- B. Depth of pathways: as per plans and details.

3.3 WATERING

- A. Water heavily to achieve full depth moisture penetration of the Stabilized pathway Profile. Water activates Stabilizer. To achieve saturation of Stabilized pathway Profile, 25 to 45 gallons of water per 1-ton must be applied. During water application randomly test for depth using a probing device to the final depth.

3.4 COMPACTION

- A. Upon thorough moisture penetration, compact aggregate screenings to 90% relative

compaction by compaction equipment. Do not begin compaction for 6 hours after placement and up to 48 hours.

- B. Take care in compacting decomposed granite when adjacent to planting and irrigation systems. Hand tamping with 8" or 10" hand tamp as necessary.

3.5 INSPECTION

- A. Finished surface of pathway shall be smooth, uniform and solid. There shall be no evidence of chipping or cracking. Cured and compacted pathway shall be firm throughout profile with no spongy areas. Loose material shall not be present on the surface. Any significant irregularities in path surface shall be repaired to the uniformity of entire installation.

3.6 MAINTENANCE

- A. Remove debris, such as paper, grass clippings, leaves or other organic material as necessary.
- B. In the months after initial installation, a minor amount of loose aggregate will appear on the surfacing surface (1/16" to 1/4"). If this material exceeds a 1/4", redistribute the material over the entire surface. Water thoroughly to the depth of 1". Compact with power roller as necessary to achieve 90% compaction. This process should be repeated as needed.
- C. If cracking occurs, sweep fines into the cracks, water thoroughly and hand tamp as necessary.

3.7 REPAIRS

- A. Excavate damaged area to the depth of the Stabilized aggregate and square off sidewalls.
- B. If area is dry, moisten damaged portion lightly.
- C. Pre-blend the dry required amount of Stabilizer powder with the proper amount of aggregate in a concrete mixer.
- D. Add water to the pre-blended aggregate and Stabilizer. Thoroughly moisten mix with 25 to 45 gallons per 1-ton of pre-blended material or to approximately 10% moisture content.
- E. Apply moistened pre-blended aggregate to excavated area to finish grade.
- F. Compact with an 8" to 10" hand tamp or roller as necessary. Keep traffic off areas for 12 to 48 hours after repair has been completed.

END OF SECTION

BENCH SPECIFICATION CUT SHEET

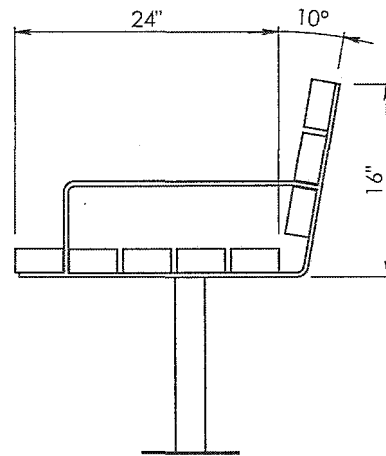
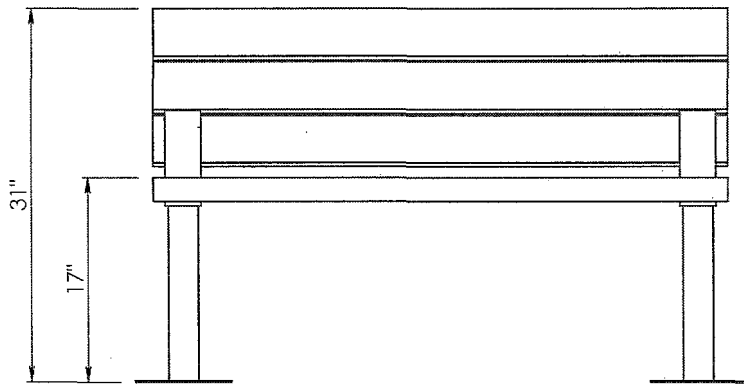
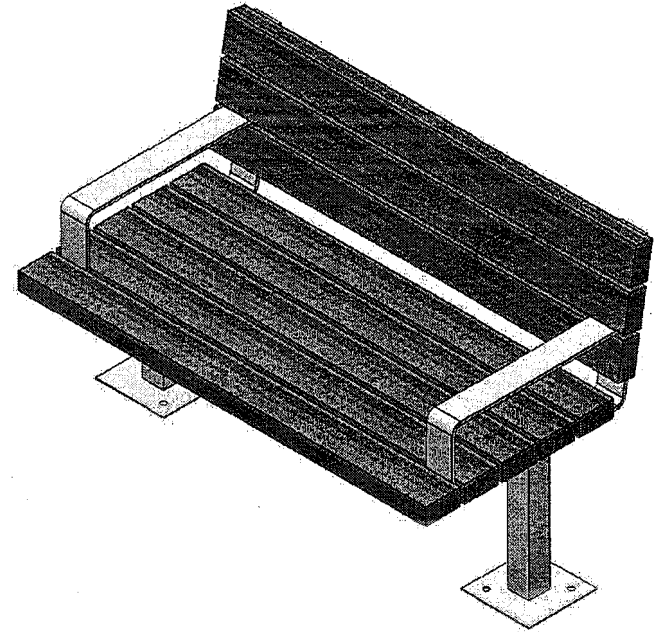
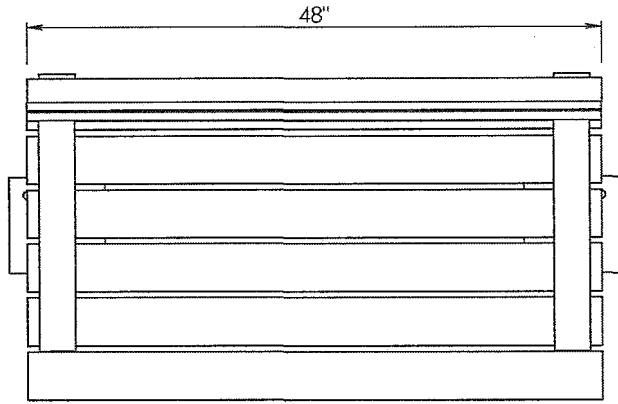

NOTES:

- STEEL FRAME WITH GALVANIZED FINISH
- SEAT, BACK AND ARM REST ARE 3/8"X3"
- LEG IS 2 1/2" SQUARE X 11 GAUGE WALL
- SLATS ARE CLEAR KILN DRIED IPE HARDWOOD WITH EASED EDGES AND ENDS
- STAINLESS STEEL FASTENERS, TAMPER PROOF
- DM BRAUN OR APPROVED EQUAL

CUSTOM HIGH PRESSURE LAMINATE SPECIFICATION

PART I - GENERAL SPECIFICATIONS

1.1 DOCUMENTS

This section of the specification forms part of the Contract Documents and is to be read, interpreted and coordinated with all other parts of the document.

1.2 SCOPE

The specification section applies only to the manufacture and supply of custom digital graphic images in Custom High Pressure Laminate.

1.3 DEFINITIONS

1.3.1 EXTERIOR GRADE CUSTOM HIGH PRESSURE LAMINATES

Custom High Pressure Laminate material composed of required layers of phenolic resin impregnated brown kraft filler paper to produce specified thicknesses, surfaced by a layers of melamine overlay, graphics imaged on saturation grade paper with UV resistant pigment based process color inks, and with an optically clear UV overlay that will resist no less that 99% of all sunlight and UV rays, as well as provides a graffiti resistant surface that allows for removal with standard cleaners.

1.3.2 MANUFACTURE

For purposes of this specification, layers of material described in 1.3.1 are to be assembled, and heat / pressure consolidated at approximately 1200 PSI at temperatures exceeding 275° Fahrenheit at manufacturer's prescribed time frames.

All manufacturing processes of printing, pressing, machining, finishing and crating to be accomplished within a single stand alone manufacturing facility to ensure consistent quality control and providing standard product delivery times of three weeks.

1.3.3 IMAGING / ARTWORK

The graphic material and images are to be supplied by and under the supervision of the architect, designer or end user on this project. To include mechanicals, text, photographs, transparencies, film and other graphic source materials incorporated into digital graphic production artwork files in manufacturer's required file formats. All graphics must be assembled by computer designers familiar with and experienced in the process of digital printing and submitting production artwork files that meet the artwork requirements of the manufacturer.

1.3.4 APPROVALS

Contractor shall submit for approval by the City at every stage of process and production as submitted by the manufacturer to the above. Work shall not proceed without receipt of written approval authorizations.

PART II - GENERAL REQUIREMENTS

Supply Custom High Pressure Laminate panels as specified and shown on the drawings and supplemental specifications, as approved by the Resident Engineer before fabrication.

2.3 INSTALLATION

Shall be performed in a workmanlike fashion consistent with standard industry practices and per approved fabrication shop drawings related to installation of Custom High Pressure Laminate and conforming to NEMA – LD3. Contractor shall provide all necessary shop drawings, manufacturing specifications and installation instruction to Resident Engineer and respective installation resources.

2.5 QUALIFICATION

Contractor to demonstrate a minimum of five (5) years previous experience with projects of similar size and scope.

2.6 SUBMITTALS AND SAMPLES

Contractor must supply project specific electronic PDF proofs for content approval and minimum 8" x 10" x .060" actual material lab samples for color and finish approval from production ready digital art work and specifications as provided by Resident Engineer.

2.7 QUALITY ASSURANCE

Quality of entire project must conform to specification and bid submittals as approved by Resident Engineer.

Quality assurance to be provided by all printing, pressing, machining, finishing and crating of project product to be accomplished within the manufacturing facility.

All signs to be delivered to the site shall be inspected for quality assurance by the Resident Engineer prior to installation.

2.8 ENVIRONMENTAL

Submit Contractor's shall comply with all worker's safety and environmental regulations.

Product to be assembled utilizing only FSC certified brown kraft paper.

Product to include a minimum of 5% Post Consumer Recycled Kraft Paper in product layout. Submit manufacturer written confirmation and materials procurement back up of such recycled content inclusion.

Meets LC50 Pittsburgh Protocol Toxicity Test. Equal to and no more toxic than wood or paper.

2.9 WARRANTY

Provide a written warranty issued in the name of the City of San Diego and authorized by the Manufacturer stating that the Custom High Pressure Laminate panels are warranted for exterior durability for ten (10) years against fading, delaminating or other material defect from date of substantial completion. Warranty is not to be pro rated.

2.10 ACCEPTABLE MANUFACTURER OR APPROVED EQUAL

iZone Imaging
2526 Charter Oaks Drive, Suite 100
Temple, Texas 76502
Toll Free: 888.464.9663
Tel: 254.778.0722
Fax: 254.778.0938
Izoneimaging.com

PART III - MANUFACTURING PROCESS

3.1 CUTTING AND SHAPING

All fabrication tools used in shaping and cutting of custom high pressure compact laminate panels must be carbide-tipped. Precision machining to be completed utilizing computer assisted cutting equipment with tooling, feed rates and spindle RPM as required for smooth mill finish edges. When used, saw blades must be no less than 10" diameter, hollow ground, 60-80 tooth, carbide tipped, running at a minimum of 3600 rpm. All cutting and shaping must be conducted in the same facility as all other manufacturing processes.

The finished product shall be smooth on all edges, and machined within a tolerance of +/- 1/16" to size specified for final installation.

3.2 SURFACE FINISH

Provide surface finish to match the Manufacturer's standard finishes of Ice, Matte or Satin and as specified in project design specifications.

Continuity of panel surfaces: Visual inspection of each panel shall reveal no visible nicks or cuts, hairline cracks, blemishes or surface defects in the surface of the finished panel.

PART IV - ART AND IMAGING

4.1 ART PREPARATION

Submit manufacturer's panels from digital production art files as supplied by the Contractor. Designated resource supplying production ready artwork files will review files and prepared per Manufacturer's artwork requirements for digital image processing. Artwork submitted to Manufacturer shall be in required file format, and stored on a commonly available removable storage media, such as memory stick, DVD or CD or may be uploaded to Manufacturer's FTP site.

4.2 ART APPROVALS

All files to be reproduced in custom High Pressure Laminate shall be submitted to the end Resident Engineer in electronic PDF Proof format for content approval and a minimum 8" x 10" x .060" actual material lab sample submitted for color and finish approval prior to production in Custom High Pressure Laminate.

4.3 ORIGINAL ARTWORK

Original artwork provided for use in production shall not be harmed in any way (writing, cutting, etc.) and will be returned to the end Resident Engineer upon successful completion and acceptance of the project.

4.4 DIGITAL IMAGING

Digital imaging shall be printed on Manufacturer's required saturation grade substrate for inclusion in lamination process and shall be of even color consistency throughout the image. All imaging shall be reproduced using UV stable pigmented inks at a resolution of no less than 300 DPI and up to 2400DPI. (Dots per Inch).

4.5 IMAGING INKS

Imaging inks used in the printing process shall be UV resistant. The imaging inks shall be pigment based aqueous inks to assure maximum durability with minimal environmental impacts.

4.6 TECHNICAL PROFICIENCY

Manufacturer shall employ printing technicians proficient in industry standard imaging techniques and be able to demonstrate capabilities in photographic reproduction, including halftones, duotones, four-color process and line art.

4.7 COLOR MATCHING

Manufacturer shall be able to match nearly the entire range of colors as represented by the Pantone Matching System (PMS) and Toyo Inks, etc. Material lab color samples are to be provided for approval of color and finish prior to production.

PART V - ASTM - MECHANICAL PERFORMANCE PROPERTIES

These standards represent the minimum acceptable qualities as tested for Custom High Pressure Laminate materials.

Property	Grade Units	Values
Weight per square foot	1/4"	1.81 lb/sf
	1/2"	3.62 lb/sf
	3/4"	5.40 lb/sf

Flexural Strength	MPa (psi) MD, min MPa (psi) CD, min	1.24×10^2 (18000) 8.27×10^1 (12000)
Impact Strength	MM (in), min	1900 (75)
Tensile Strength	MPa (psi) MD, min MPa (psi) CD, min	1.24×10^2 (18000) 8.27×10^1 (12000)
Modulus Of Elasticity	MPa (psi) MD, min MPa (psi) CD, min	1.10×10^4 (1.6×10^6) 9.65×10^3 (1800)
iZone Imaging FR Flame spread Smoke Development	ASTM E84	15 40
Rockwell Hardness	Rating, *min	70 (E Scale)
Dimensional Stability	%MD, max %CD, max	0.3 0.7
UV Resistance	Rating, *min	No change after 2000 hours
Boiling Water Resistance	Rating, *min	No Change after 2 hours

PART VI - DELIVERY, TRANSPORT, AND RELATED

6.1 INSPECTION

Prior to wrapping and crating, finished panels shall be inspected by the Resident Engineer for blemishes, chips and flatness. Any panel not meeting the requirements of this specification shall be rejected by Resident Engineer and promptly replaced by Contractor at no additional cost.

6.2 CLEANING

All panels shall be cleaned in advance of packaging/crating.

6.3 CRATING

Custom High Pressure Laminate panels shall be packaged in a manner which completely enclose the panels from exposure to the environment or transport equipment. The crates shall be lined with packing material to prevent movement and protection of panels within the crates. Complete documentation of shipment to be provided including but not limited to; Packing List, Cleaning & Maintenance Instructions and Warranty Document

6.4 DELIVERY

Delivery shall be the responsibility of the Contractor and all materials shall be insured for the total value of the contents. The Contractor must report any freight or other damage claims to the Manufacturer within 48 hours of receiving the crated panels.

PART VII - MAINTENANCE AND SERVICEABILITY

7.1 MAINTENANCE

Manufacturer's documentation covering the care, cleaning and maintenance of Custom High Pressure Laminate materials to be incorporated into project maintenance manuals to be provided with Manufacturer's product delivery.

PART VIII - INSTALLATION

8.1 INSTALLATION

Installation shall be the responsibility of the Contractor, or under the direction of the General Contractor and as specified in the contract documents and specifications. All installation processes to be executed based on Prime Fabrication Contractor's approved shop drawings and specifications and/or in accordance with NEMA Standards Section LD 3-2005.

8.2 INSPECTION – CUSTOM HIGH PRESSURE LAMINATE PANELS

Inspect completed panels for general workmanship including clarity of images, proper alignment of images on color separations, clean backgrounds, correct colors, appropriate thickness and verify all surfaces are free from blemishes and defects prior to installation.

8.3 ADHESIVES

Apply only applicable and approved adhesives as shown in approved shop drawings, as provided by Prime Fabrication Contractor, and/or NEMA LD3. All surfaces to be cleaned and prepared per adhesives manufacturer's instructions

8.4 CLEANING

Clean completed panel surfaces with a soft cloth and any good quality glass cleaner. Abrasive cleaners shall be avoided for long term usage.

8.5 INSPECTION - INSTALLATION

Inspect installation site and coordinate installation schedule with Resident Engineer.

END OF SECTION

VIENNA MODEL SHADE STRUCTURE SPECIFICATION

The shade structure shown on 37860-3-D within the semi-circle popout shall be Vienna Model by Classic Recreation System, or approved equal. Shade structures shall meet the latest California Building Code (2013). The structure calculations and specifications shall be submitted to the Resident Engineer once the product is purchased from the manufacturer, along with the product plans.

VIENNA MODEL

12'

SPECIFICATIONS

Dimensions:

Roof Dimensions, point to point	12'-0"
Eave Height	7'-2"
Roof Height @ Peak	9'-3"
Main Hip Roof	4:12 pitch
Square Feet Under Roof	±70

Columns shall be 5"x 5" steel tube, minimum .120 wall thickness.

All beams shall be structural steel tubes sized according to engineering.

Front truss shall be a modified scissor truss fabricated from tube steel.

All bolts shall be A-325 or A-307 and hidden at all connections.

Roofing shall be 24 gauge HR-36 steel pre-cut and pre-finished with ribs running with the slope of the roof.

Trim shall be 24 gauge pre-finished to match roofing.

Fascia trim shall be 24 gauge, 3½"x 3½" square.

Open or welded "C" channel, "I" beams, "S" or "Z" purlins or angle iron shall not be allowed.

Provisions for (1) light.

STANDARD SPECIFICATIONS
w/ ZINC RICH PRIMER & TGIC POWDER COAT PAINT

GENERAL:

1. All structures shall be designed and fabricated to the IBC (Latest Edition) or current local building code with standard load designs of the greater value of 20# per S.F. minimum live load and 100 mph sustained wind load or site specific conditions and the applicable zone for seismic loads.
2. All members shall be designed according to the "American Institute of Steel Construction (AISC) specifications and the American Iron and Steel Institute (AISI) specifications for cold-formed members.
3. All fabrication welds shall be in strict accordance with the structural welding code of the American Welding Society (AWS) specifications. All structural welds shall be in compliance with the requirements of "Pre-qualified" welded joints. All welding shall conform to ASTM A-233 series E-70XX electrodes - low hydrogen.
Field welding shall not be required.
4. When required, after award of bid, the shade structure manufacturer shall submit structural calculations, sealed by a registered engineer in the state in which the structure is to be erected for review and approval by the approving agency.
5. Manufacturer qualifications: All manufacturers shall have a minimum of (20) twenty years experience in the fabrication of tubular steel shade structures. Shade structure and kiosk fabrication shall be the manufacturer's primary business. Manufacturer shall have fabricated similar structures to that which is specified. All non-specified manufacturers shall submit complete shop drawings indicating type, size & gauge of material used, with detailed connections to the specifying agency or design firm at least 10 days prior to bid opening for review and written pre-approval. All bids submitted without prior approval will be rejected.

FOOTINGS & COLUMNS:

1. Footings shall be structurally engineered by the structure manufacturer to meet local codes and site conditions. (Sample footing drawings shall be made available to the contractor or owner from the manufacturer). When required for structure installation, anchor bolts shall be supplied by the owner / contractor. Columns shall be ASTM 500 grade B. Concrete footing rebar (if required) shall be ASTM A-615 grade 40 #4 bars & smaller, grade 60 #5 bars & larger. Concrete shall be 5 sack mix "Portland" cement. Maximum slump shall not exceed 4". Concrete compressive strength shall be a minimum of 2500 psi @ 28 days.

FRAME MEMBERS AND COMPRESSION RING:

1. Only American (domestic) made steel shall be used in the construction of this shelter. Mill certification shall be made available upon request. All frame members shall be one piece hollow steel shape (HSS) tube with a minimum .120 (1/8") wall thickness, sized according to engineering. All frame members shall be bolted together with bolts totally concealed. Compression rings shall be fabricated from hollow steel shape tube or flat plate steel and shall have all connections concealed from view. All tubing for frame members shall be ASTM 500 grade B. Beam end plates shall be ASTM A36 fy=36,000 psi UNO. Bolts shall be A 325's unless noted otherwise in the structural engineering calculations. *"I" beams, Angle iron, "C", "Z" or "S" purlins or beams, open or closed, shall not be allowed.*

ROOFING:

1. All roofing shall be 24 gauge Zincalume / Galvalume coated steel panels, ICBO #ER-2757, "HR-36" panels shall be 36" wide with 1½" high ribs @ 7.2". All roofing shall be pre-finished with PVF2 (Polyvinylidene Fluoride) Kynar 500 on the top side. All roof panels shall be pre-cut with ribs running with the slope of the roof. Screws & rivets shall match roof color. No exceptions taken for roof type or trim.

PAINT:

1. All frame members shall be media blasted to a white finish removing all rust, scale, oil and grease. Powder coating for all frame members shall be provisionally warranted for (5) five years with zinc rich primer (2.5-3 mils) and TGIC polyester (2.5-3 mils) minimum total 5-6 mils finish. Finish shall be a smooth uniform surface with no pits, runs or sags.

ERECTION:

1. Manufacturer shall supply complete layout and detail plans with installation instructions for the structure. The structure shall be erected in a work-man-like manner with framing, roofing and trim installed according to the manufacturer's installation instructions. Care shall be taken to avoid damaging the structure during installation. Touch up paint provided to prevent rusting. Components of the structure shall be covered and kept dry prior to erection.

WARRANTEE:

1. Manufacturer shall warranty the structure to be free from defects in material and workmanship for a period of (10) ten years from date of acceptance by owner. Warranty does not include damage from theft, fire, vandalism or acts of God. Manufacturer shall repair or replace structure components of like kind at his option, to match existing material and workmanship. Steel roof finish shall be warranted for (30) thirty years under a separate roof manufacturer's warranty. Powder coat paint shall be warranted for (5) five years after acceptance from owner against peeling, flaking and rusting. Warranty does not cover damage caused from shipping, erection of structure, lack of touchup and maintenance, overspray from lawn sprinklers or vandalism. Bolt threads are not powder coated and therefore are not covered under the powder coat warranty.

NOTE: Engineering specifications take precedence over drawings if differences occur.

NOT FOR CONSTRUCTION

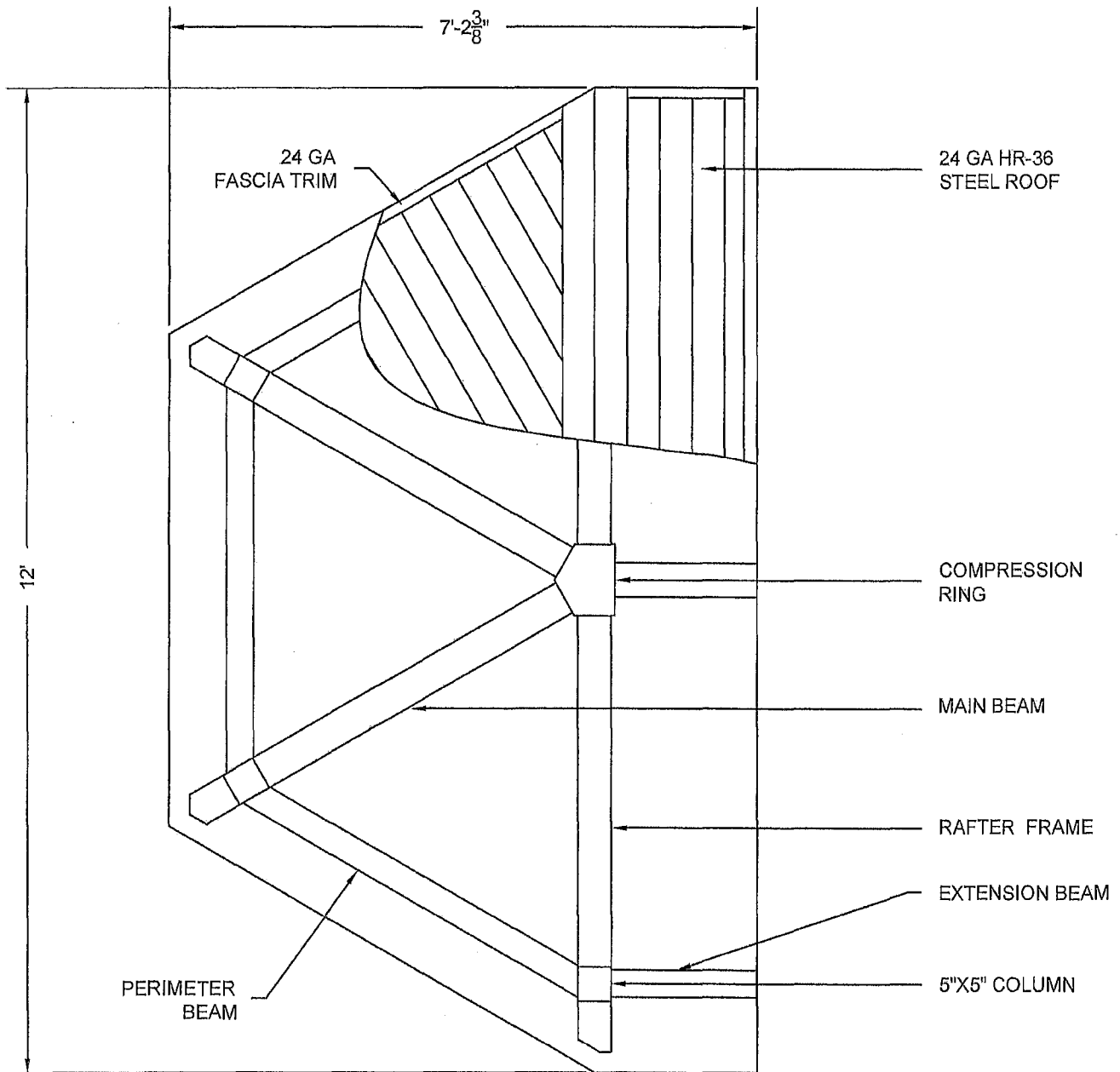

PLAN VIEW 12' VIENNA MODEL
NTS

NOT FOR CONSTRUCTION

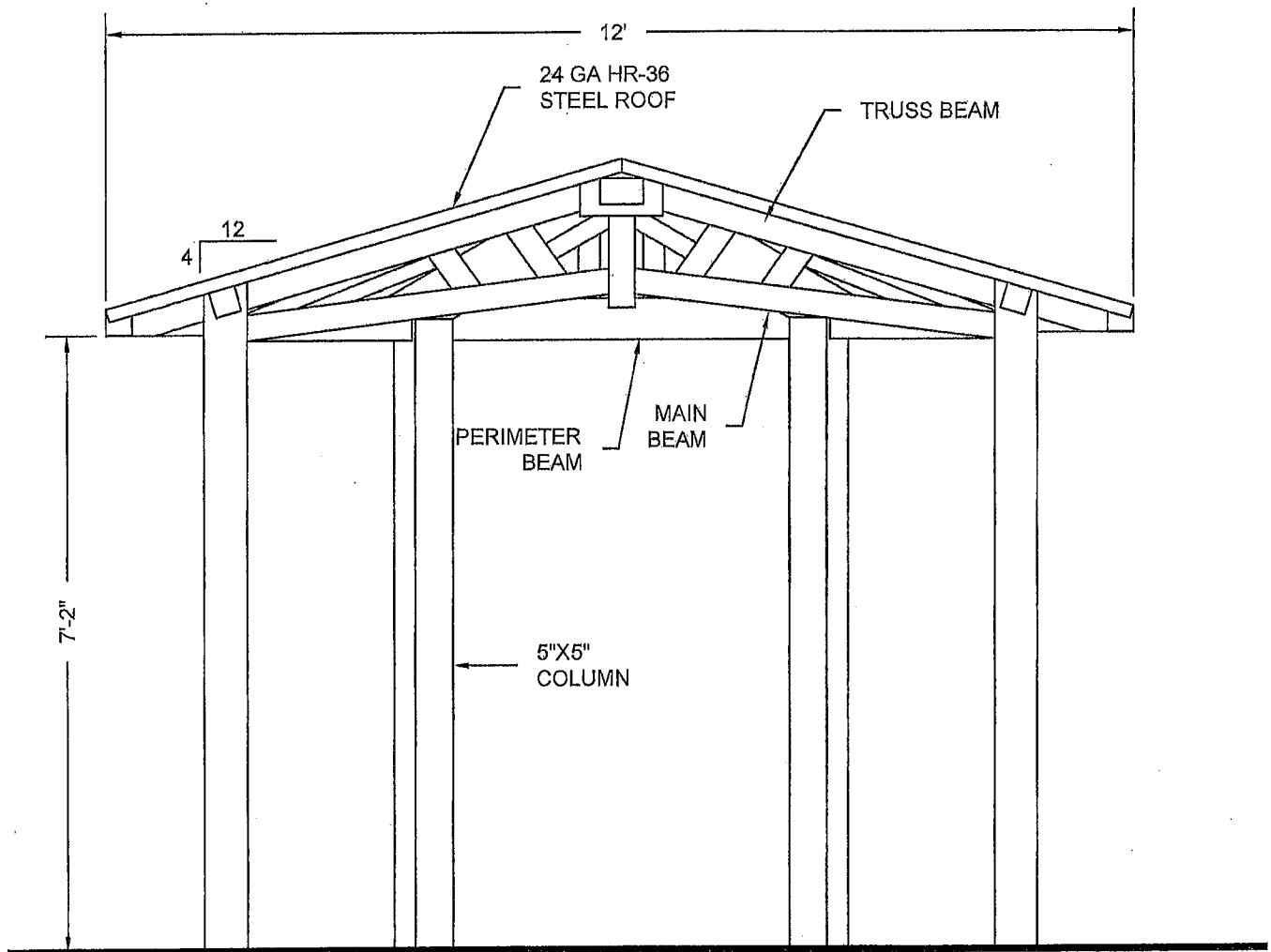

ELEVATION 12' VIENNA MODEL
NTS

NOT FOR CONSTRUCTION

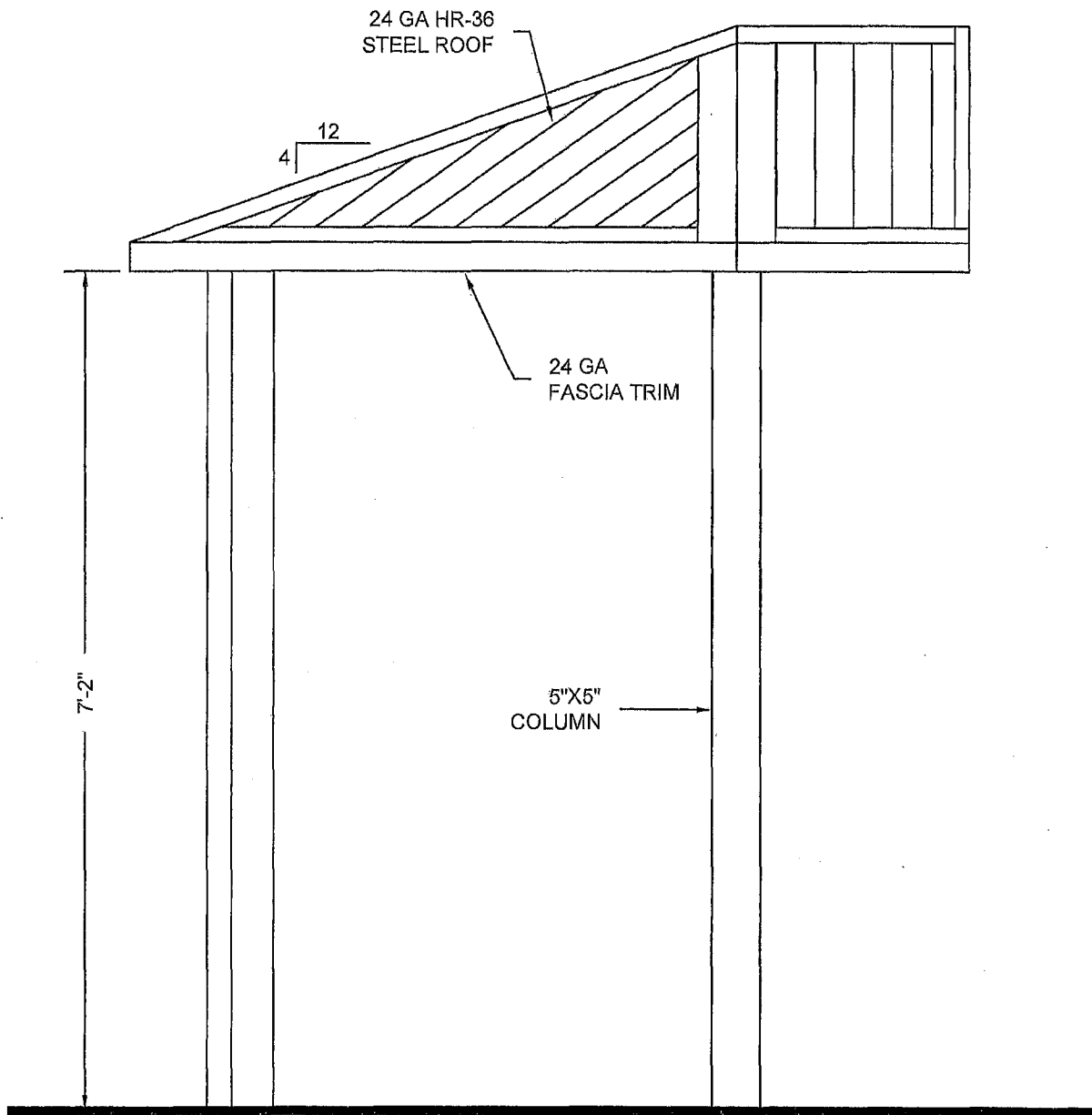

END ELEVATION 12' VIENNA MODEL
NTS

NOT FOR CONSTRUCTION

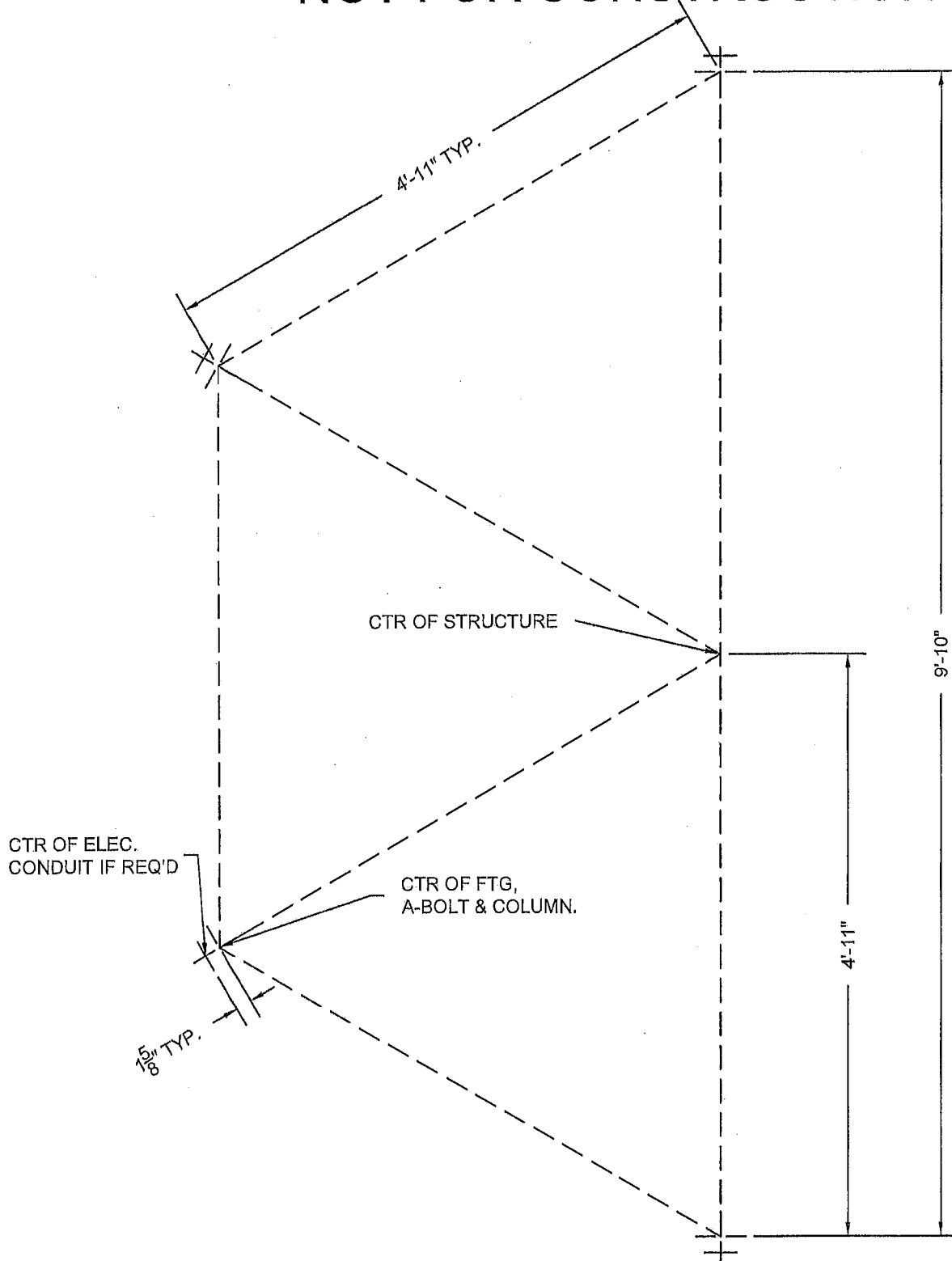

LAYOUT PLAN 12' VIENNA MODEL
NTS

NOTE: FOR ILLUSTRATION ONLY!!
 FOOTING SIZE MAY CHANGE W/
 STRUCTURAL ENGINEERING

ADJUST FTG. DEPTH FOR
 LOCAL FROST CONDITIONS

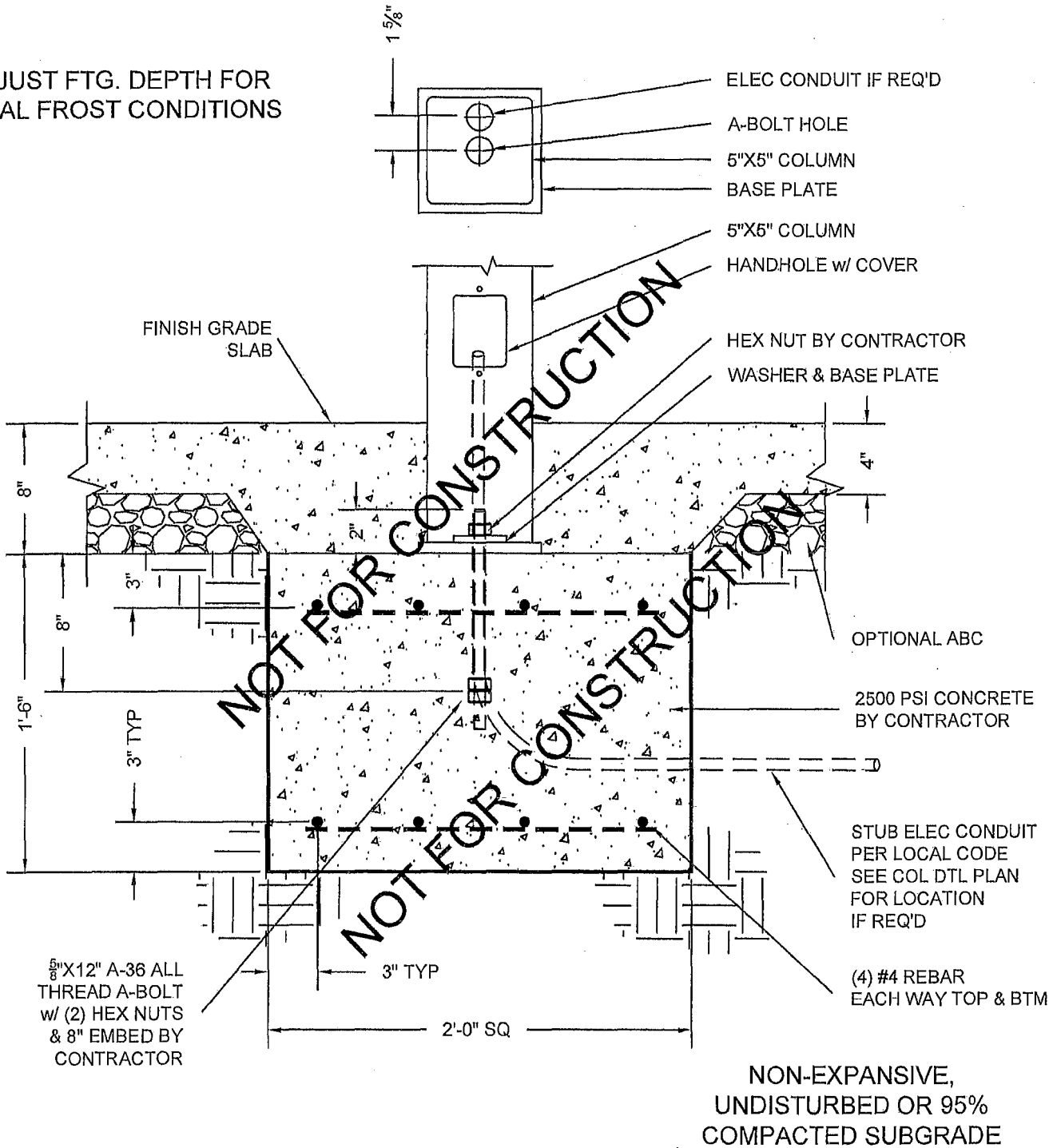

SUB-SURFACE SPREAD FOOTING DETAIL
 12' VIENNA MODEL
 NTS

NOTE: FOR ILLUSTRATION ONLY!!
FOOTING SIZE MAY CHANGE W/
STRUCTURAL ENGINEERING

ADJUST FTG. DEPTH FOR
LOCAL FROST CONDITIONS

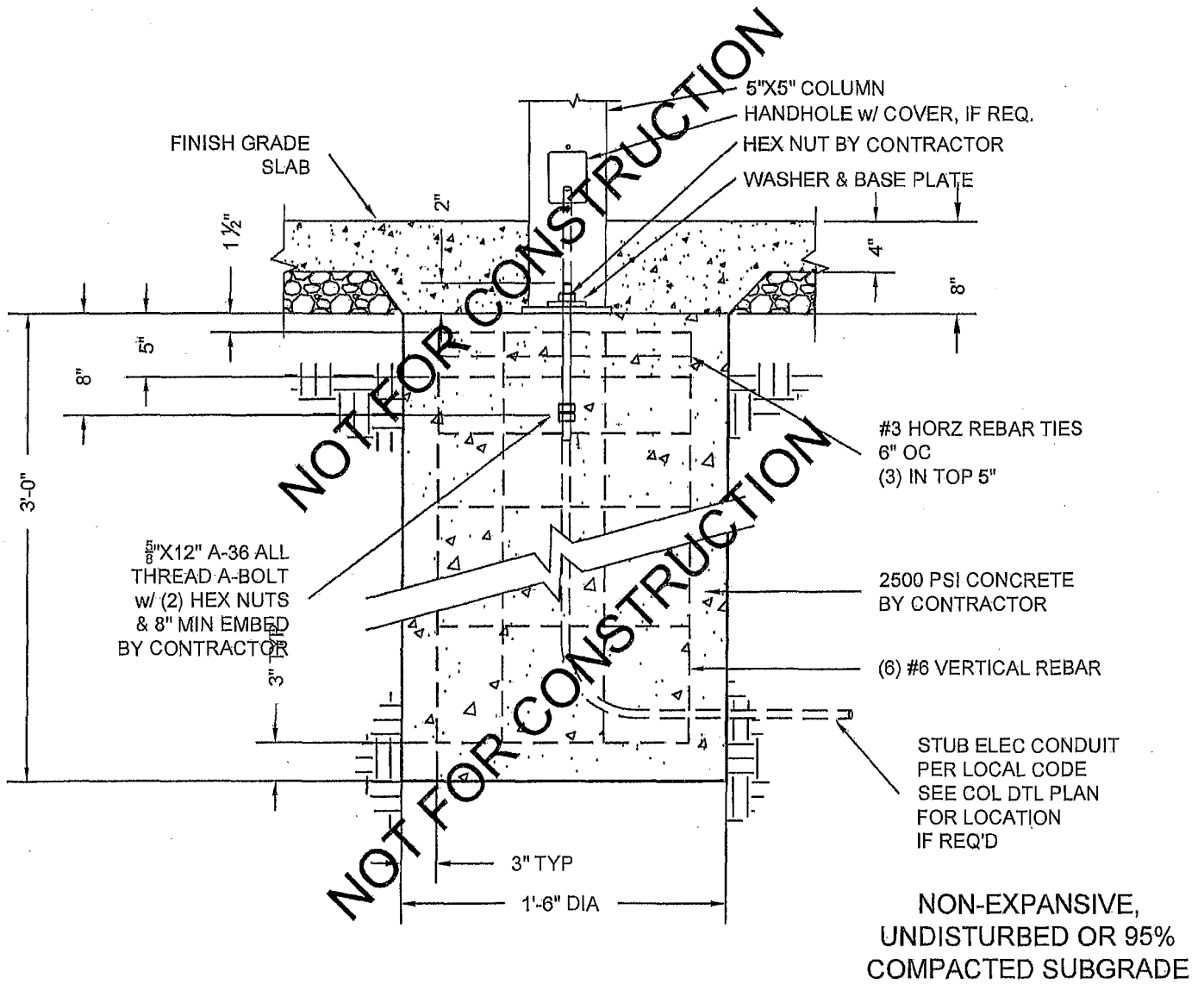
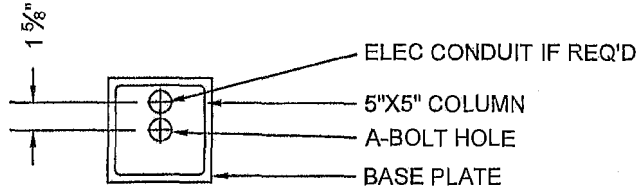

SUB-SURFACE CAISSON FOOTING DETAIL

12' VIENNA MODEL

NTS

MARANA MODEL SHADE STRUCTURE SPECIFICATION

The shade structure shown on 37860-3-D within the rectangular popout shall be Marana Model by Classic Recreation System, or approved equal. Shade structures shall meet the latest California Building Code (2013). The structure calculations and specifications shall be submitted to the Resident Engineer once the product is purchased from the manufacturer, along with the product plans.

MARANA MODEL

8'-0" X 7'-0"

SPECIFICATIONS

Dimensions:

Roof Dimensions	8'-0" x 7'-0"
Minimum Clearance @ Lower Eave	7'-6"
Roof Height @ Upper Eave	±8'-9½"
Gable Roof	2:12 pitch
Square Feet Under Roof	56

Columns shall be 5"x5" steel tube, minimum .120 wall thickness.

All beams shall be structural steel tube sized according to engineering.

All bolts shall be A-325 or A307 and hidden at all connections.

Roofing shall be 24 gauge HR-36 steel pre-cut and pre-finished with ribs running with the slope of the roof.

Trim and "J" channel shall be 24 gauge pre-finished to match roofing.

Open or welded "C" channel, "I" beams, "S" or "Z" purlins or angle iron shall not be allowed.

STANDARD SPECIFICATIONS
w/ ZINC RICH PRIMER & TGIC POWDER COAT PAINT

GENERAL:

1. All structures shall be designed and fabricated to the IBC (Latest Edition) with standard load designs of 20# per S.F. minimum live load, 100 mph wind load and the applicable zone for seismic loads.
2. All members shall be designed according to the "American Institute of Steel Construction (AISC) specifications and the American Iron and Steel Institute (AISI) specifications for cold-formed members.
3. All fabrication welds shall be in strict accordance with the structural welding code of the American Welding Society (AWS) specifications. All structural welds shall be in compliance with the requirements of "Pre-qualified" welded joints. All welding shall conform to ASTM A-233 series E-70XX electrodes - low hydrogen.
Field welding shall not be required.
4. When required, after award of bid, the shade structure manufacturer shall submit structural calculations, sealed by a registered engineer in the state in which the structure is to be erected for review and approval by the approving agency.
5. Manufacturer qualifications: All manufacturers shall have a minimum of (20) twenty years experience in the fabrication of tubular steel shade structures. Shade structure and kiosk fabrication shall be the manufacturer's primary business. Manufacturer shall have fabricated similar structures to that which is specified. All non-specified manufacturers shall submit complete shop drawings indicating type, size & gauge of material used, with detailed connections to the specifying agency or design firm at least 10 days prior to bid opening for review and written pre-approval. All bids submitted without prior approval will be rejected.

FOOTINGS & COLUMNS:

1. Footings shall be structurally engineered by the structure manufacturer to meet local codes and site conditions. (Sample footing drawings shall be made available to the contractor or owner from the manufacturer). Anchor bolts for surface mounted structures shall be supplied by the owner / contractor. Columns shall be ASTM 500 grade B. Concrete footing rebar (if required) shall be ASTM A-615 grade 40 #4 bars & smaller, grade 60 #5 bars & larger. Concrete shall be 5 sack mix "Portland" cement. Maximum slump shall not exceed 4". Compressive strength: 2500 psi @ 28 days.

FRAME MEMBERS:

1. Only American (domestic) made steel shall be used in the construction of this shelter. Mill certification shall be made available upon request. All frame members shall be one piece hollow steel shape (HSS) tube with a minimum .120 (1/8") wall thickness, sized according to engineering. All frame members shall be bolted together with bolts totally concealed. All tubing for frame members shall be ASTM 500 grade B. Beam end plates shall be ASTM A36 fy=36,000 psi UNO. Bolts shall be A 325's unless noted otherwise in the structural engineering calculations. *"I" beams, Angle iron, "C", "Z" or "S" purlins or beams, open or closed, shall not be allowed.*

ROOFING AND TRIM:

1. All roofing shall be 24 gauge Zinalume / Galvalume coated steel panels. "HR-36" panels shall be 36" wide with 1½" high ribs @ 7.2". All roofing shall be pre-finished with PVF2 (Polyvinylidene Fluoride) Kynar 500. All roof panels shall be pre-cut with ribs running with the slope of the roof. Roof fascia trim shall be 1½" "J" channel, 24 gauge Zinalume / Galvalume coated pre-finished to match the roof color. Screws & rivets shall match roof color.

PAINT:

1. All frame members shall be media blasted to a white finish removing all rust, scale, oil and grease. Powder coating for all frame members shall be provisionally warranted for (5) five years with zinc rich primer (2.5-3 mils) and TGIC polyester (2.5-3 mils) minimum total 5-6 mils finish. Finish shall be a smooth uniform surface with no pits, runs or sags.

ERECTION:

1. Manufacturer shall supply complete layout and detail plans with installation instructions for the structure. The structure shall be erected in a work-man-like manner with framing, roofing and trim installed according to the manufacturer's installation instructions. Care shall be taken to avoid damaging the structure during installation. Components of the structure shall be covered and kept dry prior to erection.

WARRANTEE:

1. Manufacturer shall warranty the structure to be free from defects in material and work-man-ship for a period of (10) ten years from date of acceptance by owner. Warranty does not include damage from theft, fire, vandalism or acts of God. Manufacturer shall repair or replace structure components of like kind at his option, to match existing material and workmanship. Steel roof finish shall be warranted for (30) thirty years under a separate roof manufacturer's warranty. Powder coat paint shall be warranted for (5) five years after acceptance from owner against peeling, flaking and rusting. Warranty does not cover damage caused from shipping, erection of structure, lack of touchup and maintenance, overspray from lawn sprinklers or vandalism. Bolt threads are not powder coated and therefore are not covered under the powder coat warranty.

NOTE: Engineering specifications take precedence over drawings if differences occur.

NOT FOR CONSTRUCTION

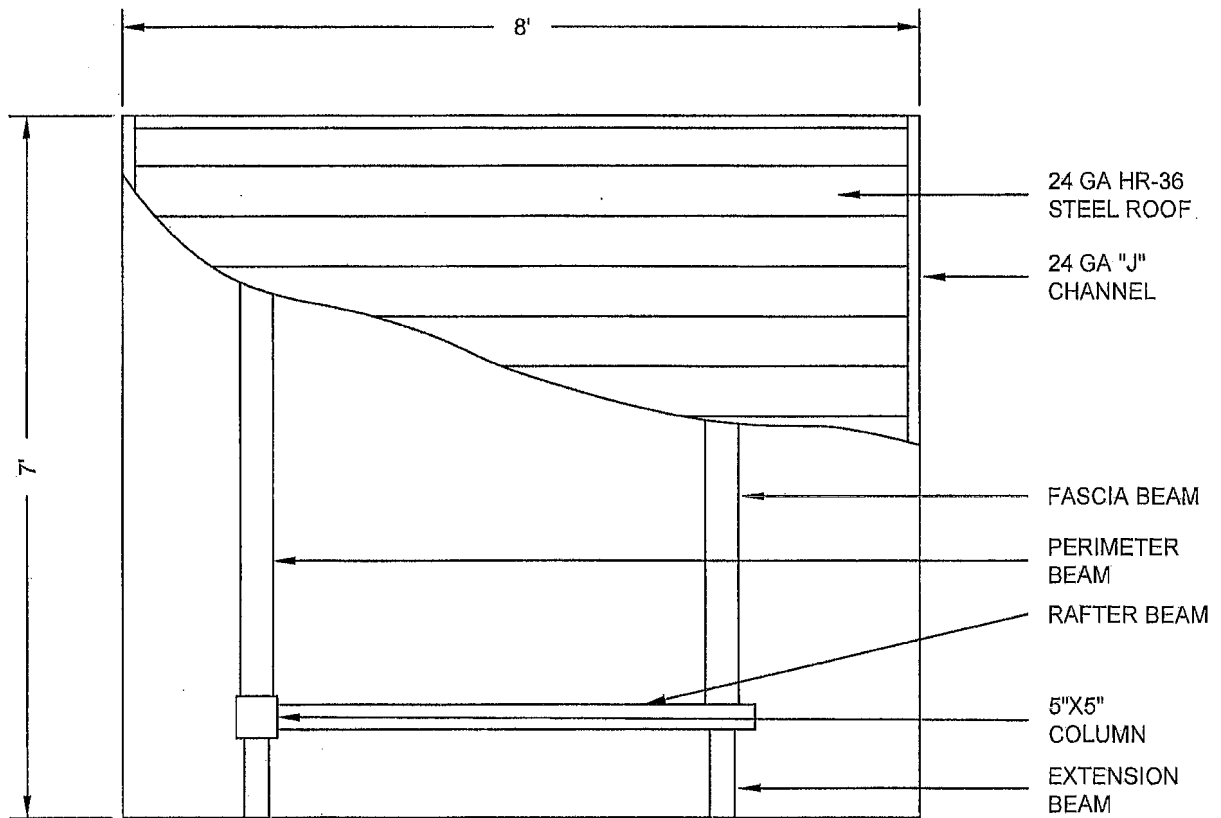

PLAN VIEW 8'X7' MARANA MODEL
NTS

NOT FOR CONSTRUCTION

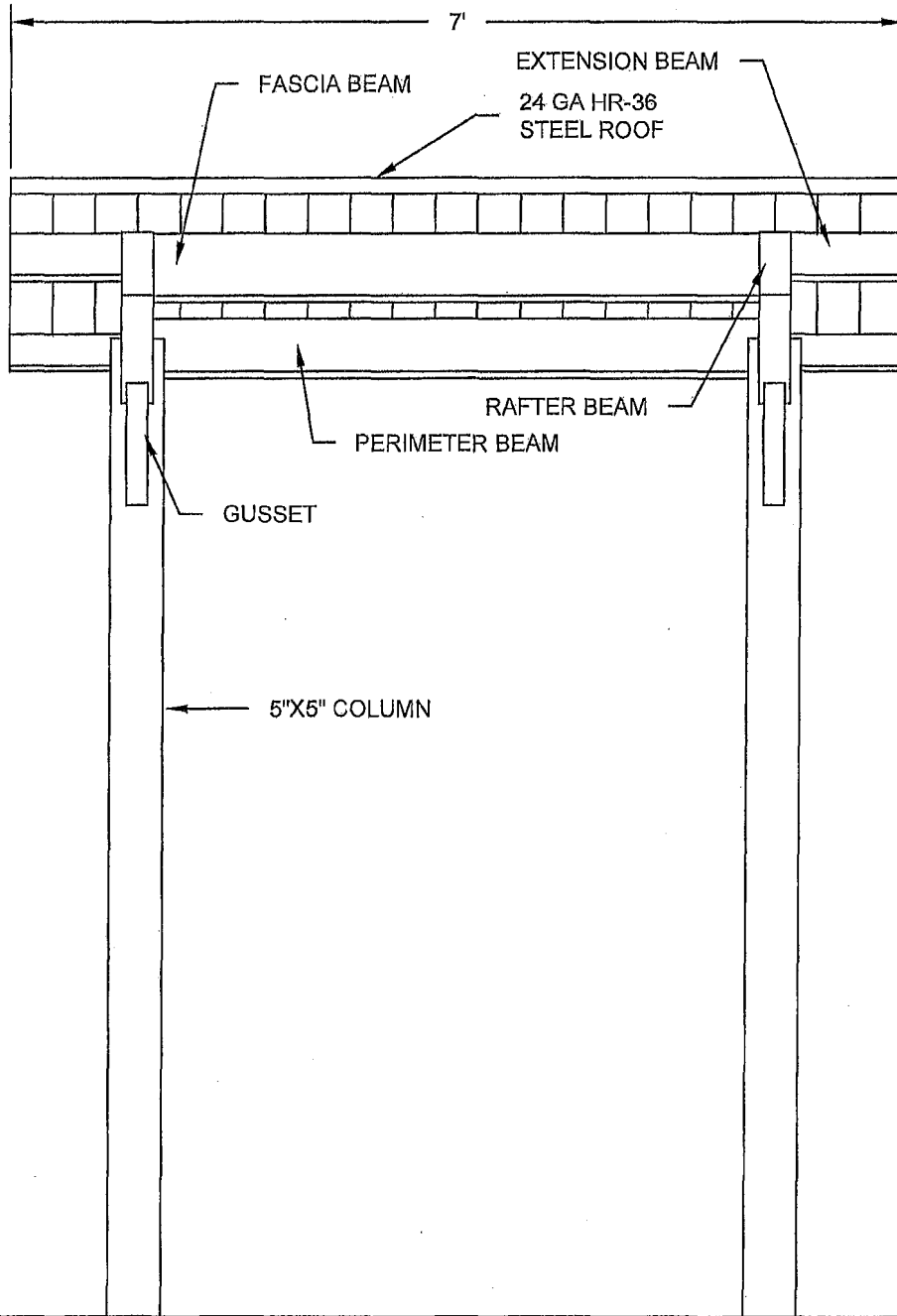

ELEVATION 8'X7' MARANA MODEL
NTS

NOT FOR CONSTRUCTION

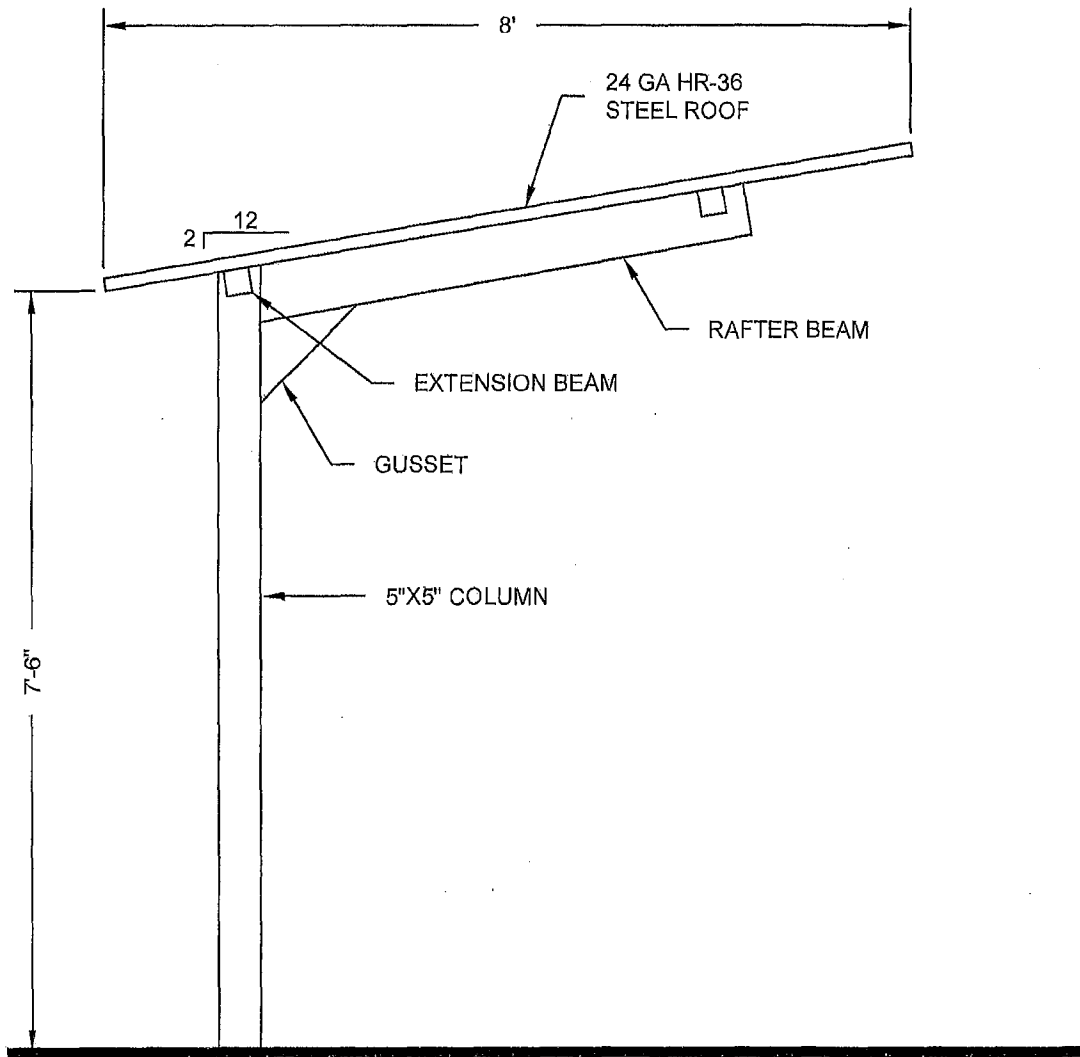

END ELEVATION 8'X7' MARANA MODEL
NTS

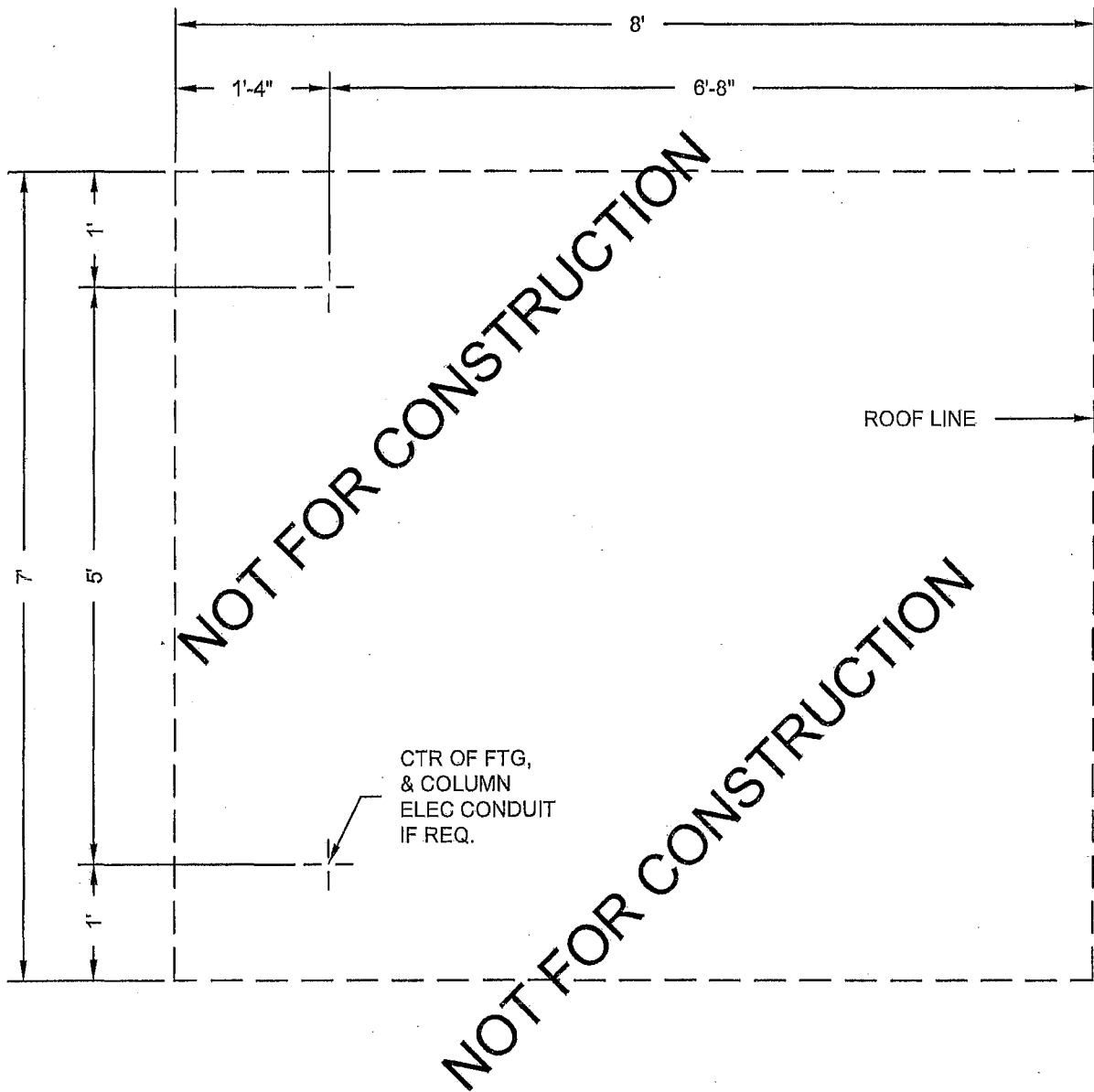

LAYOUT PLAN 8'X7' MARANA MODEL
NTS

NOTE: FOR ILLUSTRATION ONLY!!
 FOOTING SIZE MAY CHANGE W/
 STRUCTRURAL ENGINEERING

ADJUST FTG. DEPTH FOR
 LOCAL FROST CONDITIONS

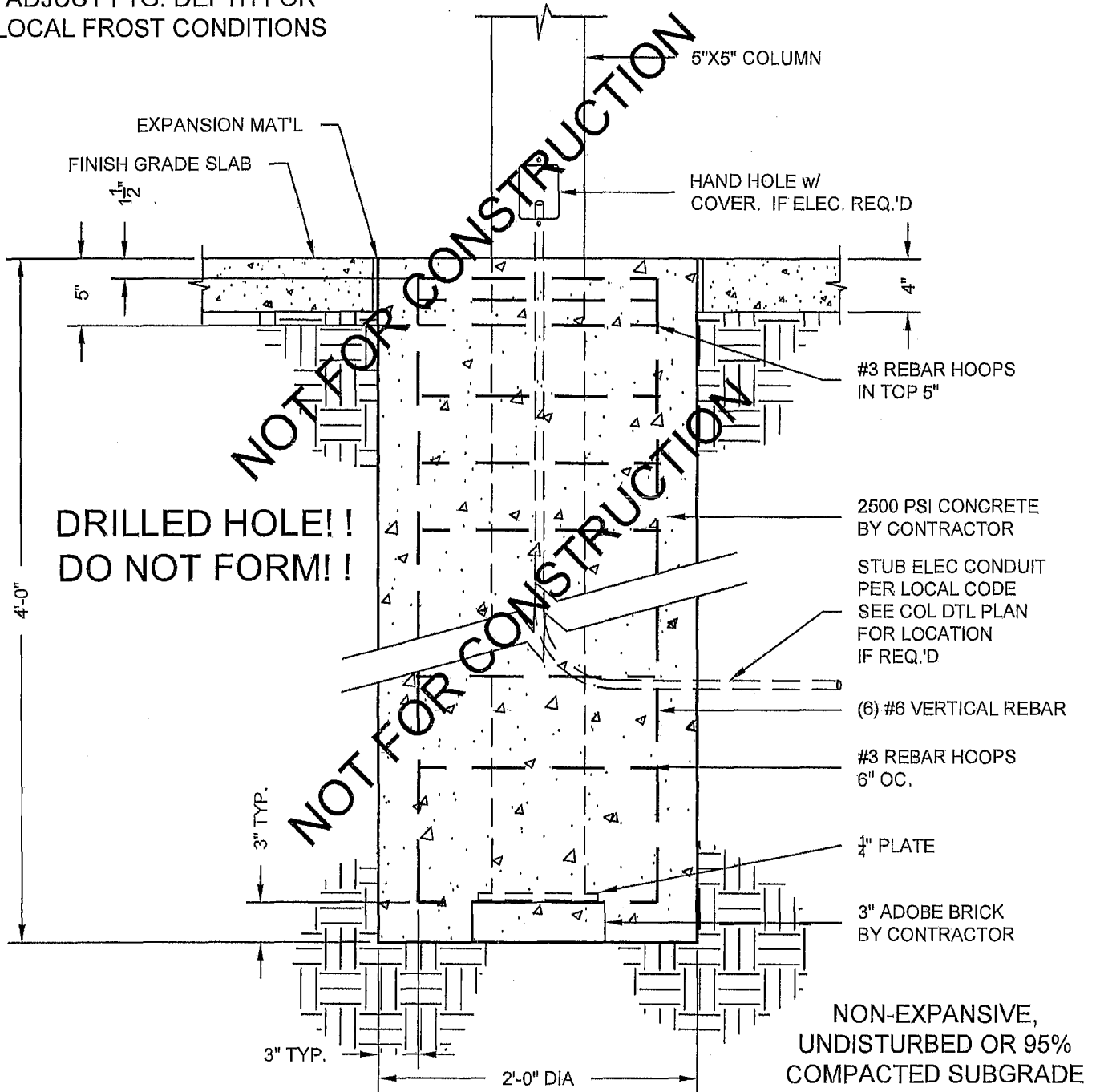

DIRECT BURY FOOTING DETAIL

8'X7' MARANA MODEL
 NTS

SUPPLEMENTARY SPECIAL PROVISIONS

APPENDICES

APPENDIX A

FINAL MITIGATED NEGATIVE DECLARATION AND SITE DEVELOPMENT PERMIT



Advanced Planning and Engineering Division
(619) 446-5460

FINAL

MITIGATED NEGATIVE DECLARATION

Project No. 266083
SCH No. 2013011032

SUBJECT: Black Mountain Natural Resources Management Plan: SITE DEVELOPMENT PERMIT (SDP) and COMMUNITY PLAN AMENDMENT for the adoption of the Black Mountain Open Space Natural Resources Management Plan (NRMP) for the Black Mountain Open Space Park (Plan). The Plan would provide guidance for the present and future use and maintenance of the Park, as well as Area Specific Management Directives (ASMDs) which satisfy the requirements of the City's MSCP Implementing Agreement for Black Mountain Open Space. The NRMP contains a proposal to revise the existing trail system on Black Mountain through closure of 11.9 miles of existing trails and development of 3.45 miles of new trail segments, which would result in impacts to biological resources.

The Plan is intended not only to make provisions for the protection and preservation of the natural resources, especially sensitive resources, but also to allow safe and accessible use of the Park to meet the needs of the present and future communities through the trail plan (Figure 2). The Plan provides for maintenance of the quality of the Park's natural environment and associated visual enjoyment of the Park's open space. In addition, this Plan is intended to identify management needs for three hundred twenty-five acres that were used to mitigate biological impacts to sensitive upland habitats associated with the San Diego County Water Authority (CWA) Emergency Storage Project (ESP). Management and monitoring of the site is required by the U.S. Fish and Wildlife Service (Biological Opinion (BO) 1-6-97-F-13) and shall be conducted in accordance with this Plan upon approval. The Plan is also intended to compliment any future Park master plan, which would include management directives for any potential new recreation sites within the Plan area.

The above mentioned trail plan is the result of a comprehensive trail analysis completed for the Black Mountain Open Space Park NRMP. Following review against multiple criteria each trail segment was categorized as Existing – Permanently Closed, Existing – To Remain Open, Existing – Proposed for Closure, or New – Proposed to Open. The resulting trail plan proposes closure of 11.97 miles of existing trail segments that are unsafe, difficult to maintain, redundant and/or negatively affect habitat values, as well as development of 3.45 miles of new segments of safe, sustainable trails in areas of moderate-to-low biological sensitivity.

The planning area is bounded by Black Mountain Road to the north and west, and Carmel Mountain Road to the south and east. The Park, which is managed as a whole, is a composite of the existing 1,014-acre Park to the north and the recently acquired 538-acre Montana Mirador site to the south. The project is located in the Rancho Penasquitos and Black Mountain Community Plan areas. Applicant: City of San Diego, Park and Recreation Department, Open Space Division.

UPDATE: September 24, 2013

Revisions to this document have been made when compared to the Draft Mitigated Negative Declaration (DMND) dated January 18, 2013. Since the circulation of the DMND the construction corridor has been expanded to allow for additional vegetation impacts if required during construction. The MMRP and Initial Study were modified to identify an additional .31 impacts to Tier II and an additional .02 impacts to Tier IIIa. In accordance with the California Environmental Quality Act, Section 15073.5 (c)(4), the addition of new information that clarifies, amplifies, or makes insignificant modification does not require recirculation as there are no new impacts and no new mitigation identified. An environmental document need only be recirculated when there is identification of new significant environmental impact or the addition of a new mitigation measure required to avoid a significant environmental impact. Therefore the addition of updated mitigation requirements within the environmental document does not affect the environmental analysis or conclusions of the MND.

- I. PROJECT DESCRIPTION: See attached Initial Study.
- II. ENVIRONMENTAL SETTING: See attached Initial Study.
- III. DETERMINATION:

The City of San Diego conducted an Initial Study which determined that the proposed project could have a significant environmental effect in the following areas(s): Biological Resources, Land Use - Multi-Habitat Planning Area (MHPA). The project requires implementation of specific mitigation identified in Section V of this Mitigated Negative Declaration (MND). The project as presented now avoids or mitigates the potentially significant environmental effects identified and the preparation of an Environmental Impact Report (EIR) would not be required.

- IV. DOCUMENTATION:

The attached Initial Study documents the reasons to support the above Determination.

- V. MITIGATION, MONITORING AND REPORTING PROGRAM (MMRP):

A. GENERAL REQUIREMENTS – PART I

Plan Check Phase (prior to permit issuance)

- 1. Prior to Bid Opening/Bid Award or beginning any construction related activity on-site, the Development Services Department (DSD) Director's Environmental Designee (ED) shall review and approve all Construction Documents (CD) (plans, specification, details, etc.) to ensure the MMRP requirements have been incorporated.

2. In addition, the ED shall verify that the MMRP Conditions/Notes that apply ONLY to the construction phases of this project are included VERBATIM, under the heading, "ENVIRONMENTAL/MITIGATION REQUIREMENTS."
3. These notes must be shown within the first three (3) sheets of the construction documents in the format specified for engineering construction document templates as shown on the City website:

<http://www.sandiego.gov/development-services/industry/standtemp.shtml>

4. The **TITLE INDEX SHEET** must also show on which pages the "Environmental/Mitigation Requirements" notes are provided.

B. GENERAL REQUIREMENTS – PART II
Post Plan Check (Prior to start of construction)

1. **PRE CONSTRUCTION MEETING IS REQUIRED TEN (10) WORKING DAYS PRIOR TO BEGINNING ANY WORK ON THIS PROJECT.** The PERMIT HOLDER/OWNER is responsible to arrange and perform this meeting by contacting the City staff from MITIGATION MONITORING COORDINATION (MMC). Attendees must also include the Permit holder's Representative(s), Job Site Superintendent and the following consultants: **Biologist**

Note: Failure of all responsible Permit Holder's representatives and consultants to attend shall require an additional meeting with all parties present.

CONTACT INFORMATION:

For Clarification of ENVIRONMENTAL REQUIREMENTS, it is required to call **MMC at 858-627-3360**

2. **MMRP COMPLIANCE:** This Project, Project Tracking System (PTS) No. 266083, shall conform to the mitigation requirements contained in the associated Environmental Document and implemented to the satisfaction of the DSD's ED, and MMC. The requirements may not be reduced or changed but may be annotated (i.e. to explain when and how compliance is being met and location of verifying proof, etc.). Additional clarifying information may also be added to other relevant plan sheets and/or specifications as appropriate (i.e., specific locations, times of monitoring, methodology, etc)

Note:

Permit Holder's Representatives must alert MMC if there are any discrepancies in the plans or notes, or any changes due to field conditions. All conflicts must be approved by MMC BEFORE the work is performed.

3. **OTHER AGENCY REQUIREMENTS:** Evidence that any other agency requirements or permits have been obtained or are in process shall be submitted to MMC for review and acceptance prior to the beginning of work or within one week of the Permit Holder obtaining documentation of those permits or requirements. Evidence shall include copies of permits, letters of resolution or other documentation issued by the responsible agency.

None required.

4. **MONITORING EXHIBITS:** All consultants (City Biologist) are required to submit, to MMC, a monitoring exhibit on a 11x17 reduction of the appropriate construction plan, such as site plan, grading, landscape, etc., marked to clearly show the specific areas including the **LIMIT OF WORK**, scope of that discipline’s work, and notes indicating when in the construction schedule that work will be performed. When necessary for clarification, a detailed methodology of how the work will be performed shall be included.

5. **OTHER SUBMITTALS AND INSPECTIONS:** The Permit Holder/Owner’s representative shall submit all required documentation, verification letters, and requests for all associated inspections to MMC for approval per the following schedule:

Document Submittal/Inspection Checklist

<i>Issue Area</i>	<i>Document submittal</i>	<i>Associated Inspection/Approvals/Note</i>
General	Consultant Qualification Letters meeting	Prior to Pre-construction
General	Consultant Const. Monitoring	Prior to or at the Pre-Construction meeting
Biology	Biology Reports	Limit of Work Verification

SPECIFIC MMRP ISSUE AREA CONDITIONS/REQUIREMENTS:

Land Use (MHPA)

I. Prior to Permit Issuance

- A. Prior to issuance of any construction permit, the DSD Environmental Designee (ED) shall verify the Applicant has accurately represented the project’s design in the Construction Documents (CDs) that are in conformance with the associated discretionary permit conditions and Exhibit “A”, and also the City’s Multi-Species Conservation Program (MSCP) Land Use Adjacency Guidelines for the Multiple Habitat Planning Area (MHPA), including identifying adjacency as the potential for direct/indirect impacts where applicable. In addition, all CDs where applicable shall show the following:
 1. **Land Development / Grading / Boundaries** –MHPA boundaries on-site and adjacent properties shall be delineated on the CDs. The ED shall ensure that all grading is included within the development footprint, specifically manufactured slopes, disturbance, and development within or adjacent to the MHPA..
 2. **Drainage / Toxins** –All new and proposed parking lots and developed area in and adjacent to the MHPA shall be designed so they do not drain directly into the MHPA, All developed and paved areas must prevent the release of toxins, chemicals, petroleum products, exotic plant materials prior to release by incorporating the use of filtration devices, planted swales and/or planted detention/desiltation basins, or other

approved permanent methods that are designed to minimize negative impacts, such as excessive water and toxins into the ecosystems of the MHPA.

3. **Staging/storage, equipment maintenance, and trash** –All areas for staging, storage of equipment and materials, trash, equipment maintenance, and other construction related activities are within the development footprint. Provide a note on the plans that states: *“All construction related activity that may have potential for leakage or intrusion shall be monitored by the Qualified Biologist/Owners Representative to ensure there is no impact to the MHPA.”*
4. **Barriers** –All new development within or adjacent to the MHPA shall provide fencing or other City approved barriers along the MHPA boundaries to direct public access to appropriate locations, to reduce domestic animal predation, and to direct wildlife to appropriate corridor crossing. Permanent barriers may include, but are not limited to, fencing (6-foot black vinyl coated chain link or equivalent), walls, rocks/boulders, vegetated buffers, and signage for access, litter, and educational purposes.
5. **Lighting** – All building, site, and landscape lighting adjacent to the MHPA shall be directed away from the preserve using proper placement and adequate shielding to protect sensitive habitat. Where necessary, light from traffic or other incompatible uses, shall be shielded from the MHPA through the utilization of including, but not limited to, earth berms, fences, and/or plant material.
6. **Invasive Plants** – Plant species within 100 feet of the MHPA shall comply with the Landscape Regulations (LDC142.0400 and per table 142-04F, Revegetation and Irrigation Requirements) and be non invasive. Landscape plans shall include a note that states: *“The ongoing maintenance requirements of the property owner shall prohibit the use of any planting that are invasive, per City Regulations, Standards, guidelines, etc., within 100 feet of the MHPA.”*
7. **Brush Management** –All new development adjacent to the MHPA is set back from the MHPA to provide the required Brush Management Zone (BMZ) 1 area (LDC Sec. 142.0412) within the development area and outside of the MHPA. BMZ 2 may be located within the MHPA and the BMZ 2 management shall be the responsibility of a HOA or other private entity.
8. **Noise**- Due to the site's location adjacent to or within the MHPA, construction noise that exceeds the maximum levels allowed shall be avoided during the breeding seasons for protected avian species such as: *California Gnatcatcher (3/1-8/15)*; if construction is proposed during the breeding season for the species, U.S. Fish and Wildlife Service protocol surveys shall be required in order to determine species presence/absence. When applicable, adequate noise reduction measures shall be incorporated.

COASTAL CALIFORNIA GNATCATCHER (Federally Threatened)

1. Prior to the issuance of any grading permit (FOR PUBLIC PROJECTS: prior to the preconstruction meeting), the City Manager (or appointed designee) shall verify that the Multi-Habitat Planning Area (MHPA) boundaries and the following project requirements regarding the coastal California gnatcatcher are shown on the construction plans:

NO CLEARING, GRUBBING, GRADING, OR OTHER CONSTRUCTION ACTIVITIES SHALL OCCUR BETWEEN MARCH 1 AND AUGUST 15, THE BREEDING SEASON OF THE COASTAL CALIFORNIA GNATCATCHER, UNTIL THE FOLLOWING REQUIREMENTS HAVE BEEN MET TO THE SATISFACTION OF THE CITY MANAGER:

- A. A QUALIFIED BIOLOGIST (POSSESSING A VALID ENDANGERED SPECIES ACT SECTION 10(a)(1)(A) RECOVERY PERMIT) SHALL SURVEY THOSE HABITAT AREAS WITHIN THE MHPA THAT WOULD BE SUBJECT TO CONSTRUCTION NOISE LEVELS EXCEEDING 60 DECIBELS [dB(A)] HOURLY AVERAGE FOR THE PRESENCE OF THE COASTAL CALIFORNIA GNATCATCHER. SURVEYS FOR THE COASTAL CALIFORNIA GNATCATCHER SHALL BE CONDUCTED PURSUANT TO THE PROTOCOL SURVEY GUIDELINES ESTABLISHED BY THE U.S. FISH AND WILDLIFE SERVICE WITHIN THE BREEDING SEASON PRIOR TO THE COMMENCEMENT OF ANY CONSTRUCTION. IF GNATCATCHERS ARE PRESENT, THEN THE FOLLOWING CONDITIONS MUST BE MET:
- A. BETWEEN MARCH 1 AND AUGUST 15, NO CLEARING, GRUBBING, OR GRADING OF OCCUPIED GNATCATCHER HABITAT SHALL BE PERMITTED. AREAS RESTRICTED FROM SUCH ACTIVITIES SHALL BE STAKED OR FENCED UNDER THE SUPERVISION OF A QUALIFIED BIOLOGIST; AND
- I. BETWEEN MARCH 1 AND AUGUST 15, NO CONSTRUCTION ACTIVITIES SHALL OCCUR WITHIN ANY PORTION OF THE SITE WHERE CONSTRUCTION ACTIVITIES WOULD RESULT IN NOISE LEVELS EXCEEDING 60 dB(A) HOURLY AVERAGE AT THE EDGE OF OCCUPIED GNATCATCHER HABITAT. AN ANALYSIS SHOWING THAT NOISE GENERATED BY CONSTRUCTION ACTIVITIES WOULD NOT EXCEED 60 dB(A) HOURLY AVERAGE AT THE EDGE OF OCCUPIED HABITAT MUST BE COMPLETED BY A QUALIFIED ACOUSTICIAN (POSSESSING CURRENT NOISE ENGINEER LICENSE OR REGISTRATION WITH MONITORING NOISE LEVEL EXPERIENCE WITH LISTED ANIMAL SPECIES) AND APPROVED BY THE CITY MANAGER AT LEAST TWO WEEKS PRIOR TO THE COMMENCEMENT OF CONSTRUCTION ACTIVITIES. PRIOR TO THE COMMENCEMENT OF CONSTRUCTION ACTIVITIES DURING THE BREEDING SEASON, AREAS RESTRICTED FROM SUCH ACTIVITIES SHALL BE STAKED OR FENCED UNDER THE SUPERVISION OF A QUALIFIED BIOLOGIST; OR
- III. AT LEAST TWO WEEKS PRIOR TO THE COMMENCEMENT OF CONSTRUCTION ACTIVITIES, UNDER THE DIRECTION OF A QUALIFIED ACOUSTICIAN, NOISE ATTENUATION MEASURES (e.g., BERMS, WALLS) SHALL BE IMPLEMENTED TO ENSURE THAT NOISE LEVELS RESULTING FROM CONSTRUCTION ACTIVITIES WILL NOT EXCEED 60 dB(A) HOURLY AVERAGE AT THE EDGE OF HABITAT OCCUPIED BY THE COASTAL CALIFORNIA GNATCATCHER. CONCURRENT WITH THE COMMENCEMENT OF CONSTRUCTION ACTIVITIES AND THE CONSTRUCTION OF NECESSARY NOISE ATTENUATION FACILITIES, NOISE MONITORING* SHALL BE CONDUCTED AT THE EDGE OF THE OCCUPIED HABITAT AREA TO ENSURE THAT NOISE LEVELS DO

NOT EXCEED 60 dB(A) HOURLY AVERAGE. IF THE NOISE ATTENUATION TECHNIQUES IMPLEMENTED ARE DETERMINED TO BE INADEQUATE BY THE QUALIFIED ACOUSTICIAN OR BIOLOGIST, THEN THE ASSOCIATED CONSTRUCTION ACTIVITIES SHALL CEASE UNTIL SUCH TIME THAT ADEQUATE NOISE ATTENUATION IS ACHIEVED OR UNTIL THE END OF THE BREEDING SEASON (AUGUST 16).

* Construction noise monitoring shall continue to be monitored at least twice weekly on varying days, or more frequently depending on the construction activity, to verify that noise levels at the edge of occupied habitat are maintained below 60 dB(A) hourly average or to the ambient noise level if it already exceeds 60 dB(A) hourly average. If not, other measures shall be implemented in consultation with the biologist and the City Manager, as necessary, to reduce noise levels to below 60 dB(A) hourly average or to the ambient noise level if it already exceeds 60 dB(A) hourly average. Such measures may include, but are not limited to, limitations on the placement of construction equipment and the simultaneous use of equipment.

B. IF COASTAL CALIFORNIA GNATCATCHERS ARE NOT DETECTED DURING THE PROTOCOL SURVEY, THE QUALIFIED BIOLOGIST SHALL SUBMIT SUBSTANTIAL EVIDENCE TO THE CITY MANAGER AND APPLICABLE RESOURCE AGENCIES WHICH DEMONSTRATES WHETHER OR NOT MITIGATION MEASURES SUCH AS NOISE WALLS ARE NECESSARY BETWEEN MARCH 1 AND AUGUST 15 AS FOLLOWS:

- I. IF THIS EVIDENCE INDICATES THE POTENTIAL IS HIGH FOR COASTAL CALIFORNIA GNATCATCHER TO BE PRESENT BASED ON HISTORICAL RECORDS OR SITE CONDITIONS, THEN CONDITION A.III SHALL BE ADHERED TO AS SPECIFIED ABOVE.
- II. IF THIS EVIDENCE CONCLUDES THAT NO IMPACTS TO THIS SPECIES ARE ANTICIPATED, NO MITIGATION MEASURES WOULD BE NECESSARY.

II. Prior to Start of Construction

A. Preconstruction Meeting

The Qualified Biologist/Owners Representative shall incorporate all MHPA construction related requirements, into the project's Biological Monitoring Exhibit (BME).

The Qualified Biologist/Owners Representative is responsible to arrange and perform a focused pre-con with all contractors, subcontractors, and all workers involved in grading or other construction activities that discusses the sensitive nature of the adjacent sensitive biological resources.

III. During Construction

A. The Qualified Biologist/Owners Representative, shall verify that all construction related activities taking place within or adjacent to the MHPA are consistent with the CDs, the

MSCP Land Use Adjacency Guidelines. The Qualified Biologist/Owners Representative shall monitor and ensure that the Land Use Adjacency Guidelines as described in Section I are being implemented.

IV. Post Construction

A. Preparation and Submittal of Monitoring Report

The Qualified Biologist/Owners Representative shall submit a final biological monitoring report to the RE/MMC within 30 days of the completion of construction that requires monitoring. The report shall incorporate the results of the MMRP/MSCP requirements per the construction documents and the BME to the satisfaction of RE/MMC.

B. BIOLOGICAL RESOURCES

I. Prior to Bid Opening/Bid Award or beginning any construction related activity on-site, the Development Services Department (DSD) Director's Environmental Designee (ED) shall verify that one of the following conditions has occurred to mitigate direct impacts to 2.78 ~~2.45~~ acres of upland habitat:

1. The applicant shall conserve 0.95 ~~0.64~~ acre of Tier II habitat, 1.79 ~~1.77~~ acres of Tier IIIA, and 0.04 acre of Tier IIIB or higher habitat within the MHPA;
2. Conserve 1.9 ~~1.28~~ acre of Tier II habitat, 2.69 ~~2.66~~ acres of Tier IIIA, and 0.06 acre of Tier IIIB or higher habitat outside of the MHPA;
3. Purchase 2.78 ~~2.45~~ acres of habitat through the City's Habitat Acquisition Fund (HAF);
4. Purchase 2.78 ~~2.45~~ acres of habitat through an approved mitigation bank such as the Cornerstone Lands Mitigation Bank;
5. Debit 2.78 ~~2.45~~ acres of habitat from mitigation credits owned by Park and Recreation.

II. General Bird Mitigation

- a. If project grading/brush management is proposed in or adjacent to native habitat during the typical bird breeding season (i.e. Feb. 1-Sept. 15), or an active nest is noted, the project biologist shall conduct a pregrading survey for active nests in the development area and within 300 feet of it, and submit a letter report to MMC prior to the preconstruction meeting.
- b. If active nests are detected, or considered likely, the report shall include mitigation in conformance with the City's Biology Guidelines and applicable State and Federal Law (i.e. appropriate follow up surveys, monitoring schedules, construction and noise barriers/buffers, etc.) to the satisfaction of the Assistant

Deputy Director (ADD) Environmental Designee of the Entitlements Division. Mitigation requirements determined by the project biologist and the ADD shall be incorporated into the project's Biological Construction Monitoring Exhibit (BCME) and all monitoring results shall be incorporated into the final biological construction monitoring report.

- c. If no nesting birds are detected per III.a above, mitigation under III a. is not required.

VI. PUBLIC REVIEW DISTRIBUTION:

Draft copies or notice of this Mitigated Negative Declaration were distributed to:

United States Government

U.S. Fish and Wildlife Service (23)

State of California

California Department of Fish and Wildlife (32A)

State Clearinghouse (46)

City of San Diego

Council Member Lightner, District 1

Historical Resource Board (87)

Park and Recreation Department

Laura Ball (MS 5D)

Betsy Miller (MS 5D)

City Attorney

Shannon Thomas (MS 93C)

Development Services Department

Helene Deisher (MS 501)

Conan Murphy (MS 501)

Michael Prinz (MS 401)

Kristy Forburger (MS 401)

Terre Lien (MS 501)

Library Dept.-Gov. Documents MS 17 (81)

Other

Rancho de los Penasquitos Planning Board (380)

Friends of Los Penasquitos Canyon Preserve (382)

Rancho Penasquitos Town Council (383)

Los Penasquitos Planning Board Citizens (385)

Black Mountain Ranch, John Becker (226C)

Environmental Law Society (164)

Sierra Club (165A)

San Diego Audubon Society (167)

Jim Pugh (167A)

California Native Plant Society (170)

Endangered Habitat League (182 and 182A)

South Coastal Information Center @ San Diego State University (210)

Frank Brown (216)

Carmen Lucas (206)
Clint Linton (215b)
San Diego Archaeological Center (212)
Save Our Heritage Organization (214)
Ron Christman (215)
Louie Guassac (215A)
San Diego County Archaeological Society (218)
Kumeyaay Cultural Heritage Preservation (223)
Kumeyaay Cultural Repatriation Committee (225)
Native American Distribution (225 A-S) **Public Notice Only**

VII. RESULTS OF PUBLIC REVIEW:

- () No comments were received during the public input period.
- () Comments were received but did not address the draft Mitigated Negative Declaration finding or the accuracy/completeness of the Initial Study. No response is necessary. The letters are attached.
- (x) Comments addressing the findings of the draft Mitigated Negative Declaration and/or accuracy or completeness of the Initial Study were received during the public input period. The letters and responses follow.

Copies of the draft Mitigated Negative Declaration, the Mitigation, Monitoring and Reporting Program and any Initial Study material are available in the office of the Entitlements Division for review, or for purchase at the cost of reproduction.



Jeffrey Szymanski, Senior Planner
Development Services Department

January 18, 2013
Date of Draft Report

Analyst: J. Szymanski

September 24, 2013
Date of Final Report

Attachments:

Figure 1 - Location/Vicinity Map
Figure 2 - Black Mountain Natural Resources Trail System
Initial Study Checklist

RECORDING REQUESTED BY
CITY OF SAN DIEGO
DEVELOPMENT SERVICES
PERMIT INTAKE, MAIL STATION 501

WHEN RECORDED MAIL TO

**CITY CLERK
MAIL STATION 2A**

THE ORIGINAL OF THIS DOCUMENT
WAS RECORDED ON JUN 11, 2014
DOCUMENT NUMBER 2014-0241191
Ernest J. Dronenburg, Jr., COUNTY RECORDER
SAN DIEGO COUNTY RECORDER'S OFFICE
TIME: 10:07 AM

SPACE ABOVE THIS LINE FOR RECORDER'S USE

INTERNAL ORDER NUMBER: SAP 21002131

**SITE DEVELOPMENT PERMIT NO. 936801
BLACK MOUNTAIN NATURAL RESOURCE
MANAGEMENT PLAN PROJECT NO. 266083 (MMRP)**
City Council

This Site Development Permit No. 936801 is granted by the City Council of the City of San Diego to City of San Diego Park and Recreation Department, Owner, and Permittee, pursuant to San Diego Municipal Code [SDMC] section 126.0502. The Black Mountain Open Space Park is bounded by Black Mountain Road to the north and west, and Carmel Mountain Road to the south and east. The site is designated as "Open Space and zoned AR 1-1 (agricultural) and RS 1-14 (residential) zone(s) of the Rancho Penasquitos and Black Mountain Ranch Community Plan areas.

Subject to the terms and conditions set forth in this Permit, permission is granted to City of San Diego Park and Recreation Department, Owner, and Permittee to implement a trail plan which will close approximately 11.9 miles of existing/unauthorized trail segments and the development of 3.45 miles of new trail segments described and identified by size, dimension, quantity, type, and location on the approved exhibits [Exhibit "A"] dated Council Date April 29, 2014, on file in the Development Services Department.

The project shall include:

- a. Revise the existing trail system on Black Mountain through closure of approximately 11.9 miles of existing/unauthorized trails and the development of approximately 3.45 miles of new trail segments; and
- b. Landscaping (planting, irrigation and landscape related improvements); and
- c. Signage; and

Page 1 of 5

- d. Public accessory improvements determined by the Development Services Department to be consistent with the land use and development standards for this site in accordance with the adopted community plan, the California Environmental Quality Act [CEQA] and the CEQA Guidelines, the City Engineer's requirements, zoning regulations, conditions of this Permit, and any other applicable regulations of the SDMC.

STANDARD REQUIREMENTS:

1. This permit must be utilized within thirty-six (36) months after the date on which all rights of appeal have expired. If this permit is not utilized in accordance with Chapter 12, Article 6, Division 1 of the SDMC within the 36 month period, this permit shall be void unless an Extension of Time has been granted. Any such Extension of Time must meet all SDMC requirements and applicable guidelines in effect at the time the extension is considered by the appropriate decision maker. This permit must be utilized by April 29, 2017.
2. No permit for the construction, occupancy, or operation of any facility or improvement described herein shall be granted, nor shall any activity authorized by this Permit be conducted on the premises until:
 - a. The Owner/Permittee signs and returns the Permit to the Development Services Department; and
 - b. The Permit is recorded in the Office of the San Diego County Recorder.
3. While this Permit is in effect, the subject property shall be used only for the purposes and under the terms and conditions set forth in this Permit unless otherwise authorized by the appropriate City decision maker.
4. This Permit is a covenant running with the subject property and all of the requirements and conditions of this Permit and related documents shall be binding upon the Owner/Permittee and any successor(s) in interest.
5. The continued use of this Permit shall be subject to the regulations of this and any other applicable governmental agency.
6. Issuance of this Permit by the City of San Diego does not authorize the Owner/Permittee for this Permit to violate any Federal, State or City laws, ordinances, regulations or policies including, but not limited to, the Endangered Species Act of 1973 [ESA] and any amendments thereto (16 U.S.C. § 1531 et seq.).
7. Construction plans shall be in substantial conformity to Exhibit "A." Changes, modifications, or alterations to the construction plans are prohibited unless appropriate application(s) or amendment(s) to this Permit have been granted.

8. All of the conditions contained in this Permit have been considered and were determined-necessary to make the findings required for approval of this Permit. The Permit holder is required to comply with each and every condition in order to maintain the entitlements that are granted by this Permit.

If any condition of this Permit, on a legal challenge by the Owner/Permittee of this Permit, is found or held by a court of competent jurisdiction to be invalid, unenforceable, or unreasonable, this Permit shall be void. However, in such an event, the Owner/Permittee shall have the right, by paying applicable processing fees, to bring a request for a new permit without the "invalid" condition(s) back to the discretionary body which approved the Permit for a determination by that body as to whether all of the findings necessary for the issuance of the proposed permit can still be made in the absence of the "invalid" condition(s). Such hearing shall be a hearing de novo, and the discretionary body shall have the absolute right to approve, disapprove, or modify the proposed permit and the condition(s) contained therein.

ENVIRONMENTAL/MITIGATION REQUIREMENTS:

9. Mitigation requirements in the Mitigation, Monitoring, and Reporting Program [MMRP] shall apply to this Permit. These MMRP conditions are hereby incorporated into this Permit by reference.

10. The mitigation measures specified in the MMRP and outlined in Mitigated Negative Declaration, NO. 266083, shall be noted on the construction plans and specifications under the heading ENVIRONMENTAL MITIGATION REQUIREMENTS.

11. The Owner/Permittee shall comply with the MMRP as specified in Mitigated Negative Declaration, NO. 266083, to the satisfaction of the Development Services Department and the City Engineer. Prior to the issuance of the "Notice to Proceed" with construction, all conditions of the MMRP shall be adhered to, to the satisfaction of the City Engineer. All mitigation measures described in the MMRP shall be implemented for the following issue areas:

Biological Resources

Land Use- Multi- Habitat Planning Area (MHPA)

ENGINEERING REQUIREMENTS:

12. The project proposes to export no material from the project site. Any excavated material that is exported, shall be exported to a legal disposal site in accordance with the Standard Specifications for Public Works Construction (the "Green Book"), 2009 edition and Regional Supplement Amendments adopted by Regional Standards Committee.

13. The drainage system proposed for this development, as shown on the Development Plans, is public and subject to approval by the City Engineer.

14. The Owner/Permittee shall incorporate any construction Best Management Practices necessary to comply with Chapter 14, Article 2, Division 1 (Grading Regulations) of the San Diego Municipal Code, into the construction plans or specifications.

15. The Storm Water Division determined that this recreational facility does not propose any new impervious surfaces and thus it is not the intent of the current Storm Water Requirements Applicability Checklist to classify this project as a Priority Project.

Therefore the project does not have any Priority Development Requirements and is not required to prepare a Water Quality Technical Report.

LANDSCAPE REQUIREMENTS:

16. Prior to approval of 100% completion of construction documents, the Permittee Department shall ensure said documents to be prepared in accordance with the Land Development Code - Landscape Regulations and Biology Guidelines to include the revegetation and hydroseeding of all disturbed land and brush management adjacent to structures within 100-feet of native/naturalized vegetation. Construction Documents shall be in substantial conformance to this permit (including Environmental conditions) and Exhibit 'A,' on file in the Office of the Development Services Department.

17. The Permittee Department shall be responsible for the establishment and maintenance of all landscape improvements shown on the approved, Final Trail Revegetation Plan, consistent with success criteria established on Exhibit 'A,' Conceptual Trail Revegetation Plan.

INFORMATION ONLY:

- The issuance of this discretionary use permit alone does not allow the immediate commencement or continued operation of the proposed use on site. The operation allowed by this discretionary use permit may only begin or recommence after all conditions listed on this permit are fully completed and all required ministerial permits have been issued and received final inspection.
- Any party on whom fees, dedications, reservations, or other exactions have been imposed as conditions of approval of this Permit, may protest the imposition within ninety days of the approval of this development permit by filing a written protest with the City Clerk pursuant to California Government Code-section 66020.
- This development may be subject to impact fees at the time of construction permit issuance.

APPROVED by the City Council
of the City of San Diego on April 29, 2014, by Resolution R-308922

Site Development Permit/PTS Approval No. 936801:
Date of Approval: April 29, 2014

AUTHENTICATED BY THE CITY OF SAN DIEGO DEVELOPMENT SERVICES
DEPARTMENT



Helene Deisher
Development Project Manager

**NOTE: Notary acknowledgment
must be attached per Civil Code
section 1189 et seq.**

The undersigned Owner/Permittee, by execution hereof, agrees to each and every condition of
this Permit and promises to perform each and every obligation of Owner/Permittee hereunder.

City of San Diego Park and Recreation Department
Owner/Permittee

By 

NAME: Chris Zirkle
TITLE: Deputy Director-Park and Recreation

**NOTE: Notary acknowledgments
must be attached per Civil Code
section 1189 et seq.**

CALIFORNIA ALL-PURPOSE ACKNOWLEDGMENT
CIVIL CODE § 1189

State of California

County of San Diego

On June 10, 2014

Date

before me, Vivian M. Gies, Notary Public

Here Insert Name and Title of the Officer

personally appeared

Helene Deisher, Chris Zirkle

Name(s) of Signer(s)

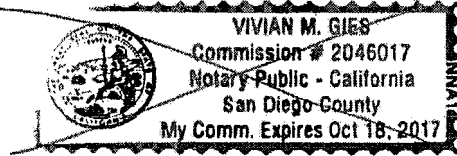

Place Notary Seal Above

who proved to me on the basis of satisfactory evidence to be the person(s) whose name(s) is/are subscribed to the within instrument and acknowledged to me that he/she/they executed the same in his/her/their authorized capacity(ies), and that by his/her/their signature(s) on the instrument the person(s), or the entity upon behalf of which the person(s) acted, executed the instrument.

I certify under PENALTY OF PERJURY under the laws of the State of California that the foregoing paragraph is true and correct.

WITNESS my hand and official seal.

Signature: Vivian M. Gies
 Signature of Notary Public

OPTIONAL

Though this section is optional, completing this information can deter alteration of the document or fraudulent reattachment of this form to an unintended document.

Description of Attached Document

Title or Type of Document: PTS 266083/BM Natural Resource Document Date: _____

Number of Pages: _____ Signer(s) Other Than Named Above: _____

Capacity(ies) Claimed by Signer(s)

Signer's Name: _____

- Corporate Officer — Title(s): _____
- Partner — Limited General
- Individual Attorney in Fact
- Trustee Guardian or Conservator
- Other: _____

Signer's Name: _____

- Corporate Officer — Title(s): _____
- Partner — Limited General
- Individual Attorney in Fact
- Trustee Guardian or Conservator
- Other: _____

Signer Is Representing: _____

Signer Is Representing: _____

NO. 7 2014
(R-2014-633)
Sub Item 'D'
4-29-2014

RESOLUTION NUMBER R- 308922

DATE OF FINAL PASSAGE APR 29 2014

A RESOLUTION OF THE COUNCIL OF THE CITY OF
SAN DIEGO APPROVING SITE DEVELOPMENT PERMIT
NO. 936801- PROJECT NO. 266083.

WHEREAS, the proposed Project by the City of San Diego, Park and Recreation Department, Open Space Division would adopt the Black Mountain Open Space Park (Park) Natural Resource Management Plan (NRMP) to provide guidance for management of environmentally sensitive resources in accordance with the Multiple Species Conservation Program (R-288455); and

WHEREAS, the NRMP includes a trail plan that will close 11.9 miles of trails, add 3.45 miles of new trails, and maintain 14.32 miles of existing trails within the Park, which is being permitted as part of this action; and

WHEREAS, to complete the Project, the City must adopt the NRMP, amend the Rancho Penasquitos Community Plan (Community Plan) to reflect the revised trails and associated policy language, approve a Site Development Permit (SDP) for physical work on the trails, and adopt the Mitigated Negative Declaration (MND) and the Mitigation Monitoring and Reporting Program (MMRP); and

WHEREAS, the Project is located in the Rancho Penasquitos Community Plan and the Black Mountain Ranch Subarea Plan areas, in the AR 1-1 (agricultural) and RS 1-14 (residential) zones; and

WHEREAS, Owner/Permittee filed an application with the City of San Diego for a Site Development Permit to implement the Project within environmentally sensitive lands; and

WHEREAS, on February 20, 2014, the Planning Commission of the City of San Diego considered Site Development Permit No. 936801 and recommended that Council approve the Permit; and

WHEREAS, on April 29, 2014, the City Council of the City of San Diego held a public hearing for the purpose of considering Site Development Permit No. 936801; and

WHEREAS, the Council of the City of San Diego has considered all maps, exhibits, and written documents contained in the file for this Project on record in the City of San Diego, and has considered the oral presentations given at the public hearing; and

WHEREAS, under Charter section 280(a)(2), this resolution is not subject to veto by the Mayor because this matter requires the City Council to act as a quasi-judicial body, a public hearing is required by law implicating due process rights of individuals affected by the decision, and the Council is required by law to consider evidence at the hearing and to make legal findings based on the evidence presented; and NOW, THEREFORE,

BE IT RESOLVED, by the Council of the City of San Diego, that it adopts the following findings with respect to Site Development Permit No. 936801:

SITE DEVELOPMENT PERMIT – SAN DIEGO MUNICIPAL CODE SECTION
126.0504

A. Findings for all Site Development Permits:

1. The proposed development will not adversely affect the applicable land use plan. The proposed Project will close 11.9 miles of trails, add 3.45 miles of new trails, and maintain 14.32 miles of trails within Black Mountain Open Space Park (Park), and also require management of Park trails in accordance with the guidelines provided in the Black Mountain Open Space Park Natural Resource Management Plan (NRMP). The proposed trails are generally less than four feet wide, except for the proposed ADA accessible Trail for All People. The trails accommodate use by pedestrians, hikers, and bikers only. Due to steep topography, rocky trail base, and reduced sight lines, the trails were determined to be unsuitable for use by equestrians. The Project requires a Site Development Permit for work within environmentally sensitive.

The NRMP will provide guidance for the present and future use and maintenance of the Park, and also provides Area Specific Management Directives (ASMDs) that satisfy the requirements of the City's Multiple Species Conservation Program (MSCP) and related Implementing Agreement. One of the objectives of the NRMP is to establish a trail system for the area that meets current recreational needs and is consistent with the natural resource protection goals of the management plan, including the Rancho Penasquitos Community Plan, the Black Mountain Ranch Subarea Plan, and the MSCP.

The General Plan recommends that canyon and other open space trails be located to take advantage of existing pathways and maintenance easements where possible. It also includes recommendations for linking communities through a trail system, as well as the implementation of the MSCP goals, policies, and objectives. The Project follows existing access roads and dirt paths where feasible, and meets this General Plan objective as a complete and linked trail system. The Park is identified as MSCP core habitat, a primary component of the MSCP preserve. The proposed trail configuration in these open space areas would be consistent with the General Plan policy to *"balance passive recreation needs/ trail use with environmental preservation."*

The Rancho Penasquitos Community Plan addresses the need for connectivity, multi-use trails, and the preservation and protection of sensitive biological resources. The Project would add trail alignments within the Park. As the communities surrounding this Park have developed, the demand has grown for recreational use of open space and the largely pristine natural environment within this Park has attracted interest from trail user groups, particularly mountain bicyclists.

The MSCP Subarea Plan identifies the following as Priority 1 within the Black Mountain Park Area: *"1. Provide clearly marked access areas and well-demarked trails and post signage to prevent off-trail access and use. Where sensitive or covered species are present, close trails during the breeding and nesting seasons if necessary. 2. Regularly assess overuse of open space areas in and surrounding the park (as determined by the Park and Recreation Department). Repair trails, and restore off-trail use areas and areas affected by erosion as soon as feasible"*. Environmental preservation is the main goal of the NRMP and the proposed trail system and corresponding management directives have been evaluated under the requirements of the NRMP.

The Project would benefit the community by enhancing recreational opportunities through the addition of multi-use trails and increased access to the park system. The closure of illicitly established trails as a result of this process would enhance the preservation and protection of sensitive biological and cultural resources within the Park. Therefore, the proposed development of the trail system will not adversely affect the applicable land use plan.

2. The proposed development will not be detrimental to the public health, safety, and welfare. The Project proposes trails to be built and maintained in accordance with the City's Trail Standards and Guidelines. These standards and guidelines were developed with the public health, safety and welfare in mind. The trails also provide recreational opportunities that have been shown to have public health benefits. The closure of some trails was also recommended to benefit public health, safety and welfare. These are trails that are in part unauthorized and not maintained or unsafe, and difficult to maintain. Therefore, the proposed development will not be detrimental to the public health, safety, and welfare.

3. The proposed development will comply with the applicable regulations of the Land Development Code, including any allowable deviations pursuant to the Land Development Code. The Project proposes to create new trails, modify, remove and enhance existing trails within and adjacent to environmentally sensitive lands. Both areas will be subject to Area Specific Management Directives (ASMDs) which satisfy the requirements of the City's Multiple Species Conservation Program (MSCP) Subarea Plan Implementing Agreement for Black Mountain Open Space. The Project will comply with the Rancho Penasquitos Community Plan, the Black Mountain Open Space Natural Resource Management Plan (NRMP), and the AR-1-1 (Agricultural-Residential) and RS-1-14 (Residential-Single Family) zoning for the site, and the Multi-Habitat Planning Area (MHPA) designation. The Project will also comply with the California Environmental Quality Act Guidelines, with all other applicable regulations of the Land Development Code, and as conditioned by the environmental MMRP and this permit. There are no proposed deviations to the Land Development Code.

B. Supplemental Findings--Environmentally Sensitive Lands

1. The site is physically suitable for the design and siting of the proposed development and the development will result in minimum disturbance to environmentally sensitive land. The adoption of the NRMP for the Black Mountain Open Space Park (Plan) provides guidance for the present and future use and maintenance of the Park, as well as Area Specific Management Directives (ASMDs) which satisfy the requirements of the City's Multiple Species Conservation Program (MSCP) Subarea Plan Implementing Agreement for Black Mountain Open Space. The site is physically suitable for trails, and currently has over 14 miles of existing trails that are proposed to remain open. 11.9 miles of existing trails are proposed for closure, resulting in improved habitat within the MHPA. The Project would develop 3.2 miles of new single-track trail segments and a 0.24 mile Americans with Disabilities Act (ADA) accessible Trail for All People. The width of the trails have been limited to 4 feet wide to minimize impacts except for the Trail for All People which would be up to 5 feet wide to accommodate people with mobility disabilities. In order to minimize construction impacts associated with cut-and-fill within the MHPA, a maximum 3 feet wide trail tread will be utilized for new trails on slopes greater than 20 percent.

The Project will not impact Narrow Endemic or MSCP-Covered Species. Three existing blue-line stream crossings will not be altered or expanded, and puncheon bridges spanning the length of the drainage features will be added within the existing trail footprint if needed to prevent

erosion based on the results of annual trail monitoring. In addition, an existing trail segment that includes a drainage crossing will be closed. In order to minimize impacts, only one new trail segment crosses a blue-line stream, and a puncheon bridge will be installed in order to exclude all construction activity and trail use from the drainage area.

Although direct impacts to wetlands and riparian habitats are avoided by the Project, the trail will cross within the buffer of a blue-line stream. Trails are a permitted use within the wetland buffer (San Diego Municipal Code [SDMC] Section 143.0130), and the proposed trail system maintains the existing wetland functions and values by avoiding direct impacts to the wetland, minimizing the distance where the trail is within the wetland buffer, and providing regular trail monitoring and maintenance. Because of these measures, the Project would not result in a loss of function or values of the wetlands and additional Federal and State permits are not anticipated.

The proposed trail system is based on the results of a Park-wide trail analysis that included sensitive species locations from both historic and recent surveys. No sensitive plant species were found within 100 feet of any proposed new trail segment. The Project will close trail segments prone to erosion and increase buffers between recreational trails and sensitive resources. Due to these elements, this Project would result in fewer impacts from human use and recreation over the long-term than the current Park trail system. Implementation of the Mitigation Monitoring and Reporting Program (MMRP), as outlined in the Mitigated Negative Declaration (MND), would reduce impacts to biological resources to below a level of significance. The site is physically suitable for the design and siting of the proposed development and the development will result in minimum disturbance to environmentally sensitive lands.

2. The proposed development will minimize the alteration of natural land forms and will not result in undue risk from geologic and erosional forces, flood hazards, or fire hazards. The Project will minimize the alteration of natural landforms through the use of low-impact construction methods. Except for the construction of the Trail for All People segment, access to areas off of existing vehicular roads shall be on foot. All tools shall be hand-carried to these areas. Impacts to landforms are additionally minimized by limiting the trail corridor to 4 feet (3 feet on slopes greater than 20%). The Project will not impact the floodplain, and as no structures other than one new puncheon bridge crossing proposed, the Project will not result in undue risk from geologic and erosional forces, flood, or fire hazards. In addition, it has been designed and will be constructed according to the Landscape Manual, the California Environmental Quality Act Guidelines, and all other applicable regulations of the Land Development Code.

3. The proposed development will be sited and designed to prevent adverse impacts on any adjacent environmentally sensitive lands. The proposed development has been sited and designed to avoid and/or prevent adverse impacts on adjacent environmentally sensitive lands. The Project utilizes existing trails and utility roads to the maximum extent feasible. No grading or alteration of the adjacent wetland or wetland buffer is proposed. The Project does not include plantings, lighting, drainage or toxic chemical sources, or brush management requirements; and allowed trail uses will not be excessively noisy, thereby preventing adverse impacts to adjacent environmentally sensitive lands. Closed trails will be

revegetated where needed. Therefore, the Project has been sited and designed to prevent adverse impacts on any adjacent environmentally sensitive lands.

4. **The proposed development will be consistent with the City of San Diego's Multiple Species Conservation Program (MSCP) Subarea Plan.** The trail development will conform to the NRMP, which provides guidance for the present and future use and maintenance of the Park, as well as Area Specific Management Directives (ASMDs) which satisfy the requirements of the City's Multiple Species Conservation Program (MSCP) Subarea Plan Implementing Agreement for Black Mountain Open Space.

The MSCP requirements are analyzed below in italics, with an explanation of Project conformance in regular font.

1. *Provide sufficient signage to clearly identify public access to the MHPA. Barriers such as vegetation, rocks/boulders or fencing may be necessary to protect highly sensitive areas. Use appropriate type of barrier based on location, setting and use.*

Existing trailheads are marked with signage and informational/educational kiosks. Directional signage and barriers are provided throughout the trail system to guide users to their desired destination, and additional signage/barriers would be installed as needed based on trail monitoring results. The proposed trail system will remove trail segments adjacent to sensitive habitats and species (e.g. San Diego barrel cactus, variegated dudleya, California adolphia) and replace them with segments in less sensitive areas.

2. *Locate trails, view overlooks, and staging areas in the least sensitive areas of the MHPA. Locate trails along the edges of urban land uses adjacent to the MHPA, or the seam between land uses (e.g., agriculture/habitat), and follow existing dirt roads as much as possible rather than entering habitat or wildlife movement areas. Avoid locating trails between two different habitat types (ecotones) for longer than necessary due to the typically heightened resource sensitivity in those locations.*

No new parking lots or view overlooks are proposed. The proposed trail system utilizes existing trail segments and utility access roads to the maximum extent practicable while meeting City standards and safety requirements for trails. New trail segments are proposed where necessary to re-route existing unsafe, unsustainable, or redundant trails, or to avoid sensitive species populations. The complete trail system, if adopted, will contain 14.32 miles of existing trails/utility access roads and only 3.45 miles of new trail. The proposed trail segments do not follow the ecotone except for the shortest distance necessary to cross habitat types.

3. *In general, avoid paving trails unless management and monitoring evidence shows otherwise. Clearly demarcate and monitor trails for degradation*

and off-trail access and use. Provide trail repair/maintenance as needed. Undertake measures to counter the effects of trail erosion including the use of stone or wood crossjoints, edge plantings of native grasses, and mulching of the trail.

The proposed trails permitted through this Project would not be paved, except for 0.24 miles for the ADA-accessible Trail for All People, which may include pervious paving. All trails are surveyed by Park staff on a rotating basis throughout the year, with a complete trail maintenance survey occurring at the end of each rainy season. Actions to repair trail damage from erosion, inappropriate use, or other factors will be taken promptly.

4. *Minimize trail widths to reduce impacts to critical resources. For the most part, do not locate trails wider than four feet in core areas or wildlife corridors. Provide trail fences or other barriers at strategic locations when protection of sensitive resources is required.*

The proposed trail segments would remain less than four feet in width in most places with the exception of the Trail for All People segment, which will be wider to accommodate ADA access.

Impacts of four feet for all single track segments are analyzed here to provide for construction impacts and future maintenance activities. Impacts from the Trail for All People segment are analyzed based on the engineering requirements. The proposed width of four feet or less will limit impacts to sensitive biological resources. If off-trail use is noted during trail maintenance surveys, areas of concern will be signed and/or barriers will be installed as necessary.

5. *Limit the extent and location of equestrian trails to the less sensitive areas of the MHPA. Locate staging areas for equestrian uses at a sufficient distance (e.g., 300-500 feet) from areas with riparian and coastal sage scrub habitats to ensure that the biological values are not impaired.*

No equestrian staging areas are proposed. Trails are collocated with existing utility access roads and existing paths where possible.

6. *Limit recreational uses to passive uses such as birdwatching, photography and trail use... Where permitted, restrain pets on leashes.*

Only passive recreational activities will be allowed on the proposed trail. Pursuant to the Municipal Code and the MSCP Framework Management Plan, pets would be required to be on leash at all times.

7. *Design and maintain trails where possible to drain into a gravel bottom or vegetated (e.g., grasslined) swale or basin to detain runoff and remove pollutants.*

The proposed trail segments will bring the trail system into compliance with this requirement by replacing existing trail segments that occur at steep grades and/or on soils prone to erosion. The proposed new segments would be constructed using appropriate outslope and frequent grade reversals to promote sheetflow of runoff, thereby limiting erosion of both the trail and adjacent terrain. In addition, the trails will be sited in locations selected for appropriate grades to minimize erosion and sedimentation.

The MSCP Subarea Plan Section 1.5.8, Specific Management Policies and Directives for the Northern Area, contains two management directives for Black Mountain Park. The MSCP requirements are analyzed below in italics, with an explanation of Project conformance in regular font.

1. *Provide clearly marked access areas and well-demarcated trails and post signage to prevent offtrail access and use. Where sensitive or covered species are present, close trails during the breeding and nesting seasons if necessary.*

See response to requirement #2 below.

2. *Regularly assess overuse of open space areas in and surrounding the park (as determined by the Park & Recreation Department). Repair trails, and restore off-trail use areas and areas affected by erosion as soon as feasible.*

The proposed trail system, including both Existing – Proposed to Remain and New – Proposed to Open segments, was evaluated based on the criteria included in these management directives (e.g. sensitive species, erosion, appropriate use type and frequency). The current trail system is signed both at access points and at trail intersections. Complete trail surveys are conducted annually by Park staff and trail maintenance projects are implemented as necessary based on survey results. The Project would complete implementation of the above management directives through lowering the number of trail-miles within the Park and re-routing existing trails to provide increased buffers for sensitive species.

5. The proposed development will not contribute to the erosion of public beaches or adversely impact local shoreline sand supply. The Project is not located on or near any public beaches. The distance from the coastline to the project area is over eight miles; therefore, the proposed development would not contribute to the erosion of public beaches or adversely impact local shoreline sand supply.

6. The nature and extent of mitigation required as a condition of the permit is reasonably related to, and calculated to alleviate, negative impacts created by the proposed development. Land Use and Biological Resources were considered during the environmental Initial Study and determined the Project could have a significant environmental effect. Subsequent revisions to the Project created the specific mitigation identified in Section V of the

MND for Project No. 266083. The Project was revised and now avoids or mitigates the potentially significant environmental effects noted above. A Mitigation Monitoring and Reporting Program has been prepared and will be implemented as determined within the MND.

The above findings are supported by the minutes, maps and exhibits, all of which are incorporated herein by this reference.

BE IT FURTHER RESOLVED, that Site Development Permit No. 936801, is granted to City of San Diego Park and Recreation Department, Owner/Permittee, under the terms and conditions set forth in the attached permit which is made a part of this resolution.

APPROVED: JAN I. GOLDSMITH, City Attorney

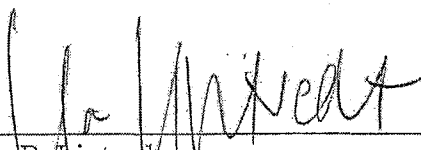
By 
Inga B. Lindveg
Deputy City Attorney

IBL:mm
04/10/14
Or.Dept:DSD
Doc. No.: 759113_3

Attachment: Exhibit A, Site Development Permit

I hereby certify that the foregoing Resolution was passed by the Council of the City of San Diego, at this meeting of APR 29 2014.

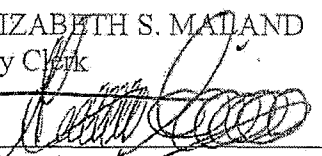
ELIZABETH S. MAILAND
City Clerk
By 
Deputy City Clerk

Passed by the Council of The City of San Diego on April 29, 2014, by the following vote:

YEAS: LIGHTNER, HARRIS, GLORIA, COLE, KERSEY, ZAPP,
SHERMAN, & ALVAREZ.

NAYS: NONE.

NOT PRESENT: EMERALD.

RECUSED: NONE.

AUTHENTICATED BY:

KEVIN L. FAULCONER

Mayor of The City of San Diego, California

ELIZABETH S. MALAND

City Clerk of The City of San Diego, California

(Seal)

By: Gil Sanchez, Deputy

I HEREBY CERTIFY that the above and foregoing is a full, true and correct copy of
RESOLUTION NO. R-308922, approved on April 29, 2014. The date of final passage is
April 29, 2014.

ELIZABETH S. MALAND

City Clerk of The City of San Diego, California

(Seal)

By:  Deputy

APPENDIX B
FIRE HYDRANT METER PROGRAM

CITY OF SAN DIEGO CALIFORNIA DEPARTMENT INSTRUCTIONS	NUMBER DI 55.27	DEPARTMENT Water Department
SUBJECT FIRE HYDRANT METER PROGRAM (FORMERLY: CONSTRUCTION METER PROGRAM)	PAGE 1 OF 10	EFFECTIVE DATE October 15, 2002
	SUPERSEDES DI 55.27	DATED April 21, 2000

1. **PURPOSE**

- 1.1 To establish a Departmental policy and procedure for issuance, proper usage and charges for fire hydrant meters.

2. **AUTHORITY**

- 2.1 All authorities and references shall be current versions and revisions.
- 2.2 San Diego Municipal Code (NC) Chapter VI, Article 7, Sections 67.14 and 67.15
- 2.3 Code of Federal Regulations, Safe Drinking Water Act of 1986
- 2.4 California Code of Regulations, Titles 17 and 22
- 2.5 California State Penal Code, Section 498B.0
- 2.6 State of California Water Code, Section 110, 500-6, and 520-23
- 2.7 Water Department Director

Reference

- 2.8 State of California Guidance Manual for Cross Connection Programs
- 2.9 American Water Works Association Manual M-14, Recommended Practice for Backflow Prevention
- 2.10 American Water Works Association Standards for Water Meters
- 2.11 U.S.C. Foundation for Cross Connection Control and Hydraulic Research Manual

3. **DEFINITIONS**

- 3.1 **Fire Hydrant Meter:** A portable water meter which is connected to a fire hydrant for the purpose of temporary use. (These meters are sometimes referred to as Construction Meters.)

CITY OF SAN DIEGO CALIFORNIA DEPARTMENT INSTRUCTIONS	NUMBER DI 55.27	DEPARTMENT Water Department
SUBJECT FIRE HYDRANT METER PROGRAM (FORMERLY: CONSTRUCTION METER PROGRAM)	PAGE 2 OF 10	EFFECTIVE DATE October 15, 2002
	SUPERSEDES DI 55.27	DATED April 21, 2000

3.2 **Temporary Water Use:** Water provided to the customer for no longer than twelve (12) months.

3.3 **Backflow Preventor:** A Reduced Pressure Principal Assembly connected to the outlet side of a Fire Hydrant Meter.

4. **POLICY**

4.1 The Water Department shall collect a deposit from every customer requiring a fire hydrant meter and appurtenances prior to providing the meter and appurtenances (see Section 7.1 regarding the Fees and Deposit Schedule). The deposit is refundable upon the termination of use and return of equipment and appurtenances in good working condition.

4.2 Fire hydrant meters will have a 2 ½" swivel connection between the meter and fire hydrant. The meter shall not be connected to the 4" port on the hydrant. All Fire Hydrant Meters issued shall have a Reduced Pressure Principle Assembly (RP) as part of the installation. Spanner wrenches are the only tool allowed to turn on water at the fire hydrant.

4.3 The use of private hydrant meters on City hydrants is prohibited, with exceptions as noted below. All private fire hydrant meters are to be phased out of the City of San Diego. All customers who wish to continue to use their own fire hydrant meters must adhere to the following conditions:

a. Meters shall meet all City specifications and American Water Works Association (AWWA) standards.

b. Customers currently using private fire hydrant meters in the City of San Diego water system will be allowed to continue using the meter under the following conditions:

1. The customer must submit a current certificate of accuracy and calibration results for private meters and private backflows annually to the City of San Diego, Water Department, Meter Shop.

CITY OF SAN DIEGO CALIFORNIA DEPARTMENT INSTRUCTIONS	NUMBER DI 55.27	DEPARTMENT Water Department
SUBJECT FIRE HYDRANT METER PROGRAM (FORMERLY: CONSTRUCTION METER PROGRAM)	PAGE 3 OF 10	EFFECTIVE DATE October 15, 2002
	SUPERSEDES DI 55.27	DATED April 21, 2000

2. The meter must be properly identifiable with a clearly labeled serial number on the body of the fire hydrant meter. The serial number shall be plainly stamped on the register lid and the main casing. Serial numbers shall be visible from the top of the meter casing and the numbers shall be stamped on the top of the inlet casing flange.
3. All meters shall be locked to the fire hydrant by the Water Department, Meter Section (see Section 4.7).
4. All meters shall be read by the Water Department, Meter Section (see Section 4.7).
5. All meters shall be relocated by the Water Department, Meter Section (see Section 4.7).
6. These meters shall be tested on the anniversary of the original test date and proof of testing will be submitted to the Water Department, Meter Shop, on a yearly basis. If not tested, the meter will not be allowed for use in the City of San Diego.
7. All private fire hydrant meters shall have backflow devices attached when installed.
8. The customer must maintain and repair their own private meters and private backflows.
9. The customer must provide current test and calibration results to the Water Department, Meter Shop after any repairs.
10. When private meters are damaged beyond repair, these private meters will be replaced by City owned fire hydrant meters.

CITY OF SAN DIEGO CALIFORNIA DEPARTMENT INSTRUCTIONS	NUMBER DI 55.27	DEPARTMENT Water Department
SUBJECT FIRE HYDRANT METER PROGRAM (FORMERLY: CONSTRUCTION METER PROGRAM)	PAGE 4 OF 10	EFFECTIVE DATE October 15, 2002
	SUPERSEDES DI 55.27	DATED April 21, 2000

11. When a private meter malfunctions, the customer will be notified and the meter will be removed by the City and returned to the customer for repairs. Testing and calibration results shall be given to the City prior to any re-installation.
 12. The register shall be hermetically sealed straight reading and shall be readable from the inlet side. Registration shall be in hundred cubic feet.
 13. The outlet shall have a 2 ½ "National Standards Tested (NST) fire hydrant male coupling.
 14. Private fire hydrant meters shall not be transferable from one contracting company to another (i.e. if a company goes out of business or is bought out by another company).
- 4.4 All fire hydrant meters and appurtenances shall be installed, relocated and removed by the City of San Diego, Water Department. All City owned fire hydrant meters and appurtenances shall be maintained by the City of San Diego, Water Department, Meter Services.
- 4.5 If any fire hydrant meter is used in violation of this Department Instruction, the violation will be reported to the Code Compliance Section for investigation and appropriate action. Any customer using a fire hydrant meter in violation of the requirements set forth above is subject to fines or penalties pursuant to the Municipal Code, Section 67.15 and Section 67.37.
- 4.6 **Conditions and Processes for Issuance of a Fire Hydrant Meter**
- Process for Issuance
- a. Fire hydrant meters shall only be used for the following purposes:
 1. Temporary irrigation purposes not to exceed one year.

CITY OF SAN DIEGO CALIFORNIA DEPARTMENT INSTRUCTIONS	NUMBER DI 55.27	DEPARTMENT Water Department
SUBJECT FIRE HYDRANT METER PROGRAM (FORMERLY: CONSTRUCTION METER PROGRAM)	PAGE 5 OF 10	EFFECTIVE DATE October 15, 2002
	SUPERSEDES DI 55.27	DATED April 21, 2000

2. Construction and maintenance related activities (see Tab 2).
- b. No customer inside or outside the boundaries of the City of San Diego Water Department shall resell any portion of the water delivered through a fire hydrant by the City of San Diego Water Department.
 - c. The City of San Diego allows for the issuance of a temporary fire hydrant meter for a period not to exceed 12 months (365 days). An extension can only be granted in writing from the Water Department Director for up to 90 additional days. A written request for an extension by the consumer must be submitted at least 30 days prior to the 12 month period ending. No extension shall be granted to any customer with a delinquent account with the Water Department. No further extensions shall be granted.
 - d. Any customer requesting the issuance of a fire hydrant meter shall file an application with the Meter Section. The customer must complete a "Fire Hydrant Meter Application" (Tab 1) which includes the name of the company, the party responsible for payment, Social Security number and/or California ID, requested location of the meter (a detailed map signifying an exact location), local contact person, local phone number, a contractor's license (or a business license), description of specific water use, duration of use at the site and full name and address of the person responsible for payment.
 - e. At the time of the application the customer will pay their fees according to the schedule set forth in the Rate Book of Fees and Charges, located in the City Clerk's Office. All fees must be paid by check, money order or cashiers check, made payable to the City Treasurer. Cash will not be accepted.
 - f. No fire hydrant meters shall be furnished or relocated for any customer with a delinquent account with the Water Department.
 - g. After the fees have been paid and an account has been created, the

CITY OF SAN DIEGO CALIFORNIA DEPARTMENT INSTRUCTIONS	NUMBER DI 55.27	DEPARTMENT Water Department
SUBJECT FIRE HYDRANT METER PROGRAM (FORMERLY: CONSTRUCTION METER PROGRAM)	PAGE 6 OF 10	EFFECTIVE DATE October 15, 2002
	SUPERSEDES DI 55.27	DATED April 21, 2000

meter shall be installed within 48 hours (by the second business day). For an additional fee, at overtime rates, meters can be installed within 24 hours (within one business day).

4.7 Relocation of Existing Fire Hydrant Meters

- a. The customer shall call the Fire Hydrant Meter Hotline (herein referred to as “Hotline”), a minimum of 24 hours in advance, to request the relocation of a meter. A fee will be charged to the existing account, which must be current before a work order is generated for the meter’s relocation.
- b. The customer will supply in writing the address where the meter is to be relocated (map page, cross street, etc). The customer must update the original Fire Hydrant Meter Application with any changes as it applies to the new location.
- c. Fire hydrant meters shall be read on a monthly basis. While fire hydrant meters and backflow devices are in service, commodity, base fee and damage charges, if applicable, will be billed to the customer on a monthly basis. If the account becomes delinquent, the meter will be removed.

4.8 Disconnection of Fire Hydrant Meter

- a. After ten (10) months a “Notice of Discontinuation of Service” (Tab 3) will be issued to the site and the address of record to notify the customer of the date of discontinuance of service. An extension can only be granted in writing from the Water Department Director for up to 90 additional days (as stated in Section 4.6C) and a copy of the extension shall be forwarded to the Meter Shop Supervisor. If an extension has not been approved, the meter will be removed after twelve (12) months of use.
- b. Upon completion of the project the customer will notify the Meter Services office via the Hotline to request the removal of the fire hydrant meter and appurtenances. A work order will be generated

CITY OF SAN DIEGO CALIFORNIA DEPARTMENT INSTRUCTIONS	NUMBER DI 55.27	DEPARTMENT Water Department
SUBJECT FIRE HYDRANT METER PROGRAM (FORMERLY: CONSTRUCTION METER PROGRAM)	PAGE 7 OF 10	EFFECTIVE DATE October 15, 2002
	SUPERSEDES DI 55.27	DATED April 21, 2000

for removal of the meter.

- c. Meter Section staff will remove the meter and backflow prevention assembly and return it to the Meter Shop. Once returned to the Meter Shop the meter and backflow will be tested for accuracy and functionality.
- d. Meter Section Staff will contact and notify Customer Services of the final read and any charges resulting from damages to the meter and backflow or its appurtenance. These charges will be added on the customer's final bill and will be sent to the address of record. Any customer who has an outstanding balance will not receive additional meters.
- e. Outstanding balances due may be deducted from deposits and any balances refunded to the customer. Any outstanding balances will be turned over to the City Treasurer for collection. Outstanding balances may also be transferred to any other existing accounts.

5. **EXCEPTIONS**

- 5.1 Any request for exceptions to this policy shall be presented, in writing, to the Customer Support Deputy Director, or his/her designee for consideration.

6. **MOBILE METER**

- 6.1 Mobile meters will be allowed on a case by case basis. All mobile meters will be protected by an approved backflow assembly and the minimum requirement will be a Reduced Pressure Principal Assembly. The two types of Mobile Meters are vehicle mounted and floating meters. Each style of meters has separate guidelines that shall be followed for the customer to retain service and are described below:

- a) **Vehicle Mounted Meters:** Customer applies for and receives a City owned Fire Hydrant Meter from the Meter Shop. The customer mounts the meter on the vehicle and brings it to the Meter Shop for

CITY OF SAN DIEGO CALIFORNIA DEPARTMENT INSTRUCTIONS	NUMBER DI 55.27	DEPARTMENT Water Department
SUBJECT FIRE HYDRANT METER PROGRAM (FORMERLY: CONSTRUCTION METER PROGRAM)	PAGE 8 OF 10	EFFECTIVE DATE October 15, 2002
	SUPERSEDES DI 55.27	DATED April 21, 2000

inspection. After installation is approved by the Meter Shop the vehicle and meter shall be brought to the Meter Shop on a monthly basis for meter reading and on a quarterly basis for testing of the backflow assembly. Meters mounted at the owner's expense shall have the one year contract expiration waived and shall have meter or backflow changed if either fails.

- b) **Floating Meters:** Floating Meters are meters that are not mounted to a vehicle. **(Note: All floating meters shall have an approved backflow assembly attached.)** The customer shall submit an application and a letter explaining the need for a floating meter to the Meter Shop. The Fire Hydrant Meter Administrator, after a thorough review of the needs of the customer, (i.e. number of jobsites per day, City contract work, lack of mounting area on work vehicle, etc.), may issue a floating meter. At the time of issue, it will be necessary for the customer to complete and sign the "Floating Fire Hydrant Meter Agreement" which states the following:

- 1) The meter will be brought to the Meter Shop at 2797 Caminito Chollas, San Diego on the third week of each month for the monthly read by Meter Shop personnel.
- 2) Every other month the meter will be read and the backflow will be tested. This date will be determined by the start date of the agreement.

If any of the conditions stated above are not met the Meter Shop has the right to cancel the contract for floating meter use and close the account associated with the meter. The Meter Shop will also exercise the right to refuse the issuance of another floating meter to the company in question.

Any Fire Hydrant Meter using reclaimed water shall not be allowed use again with any potable water supply. The customer shall incur the cost of replacing the meter and backflow device in this instance.

CITY OF SAN DIEGO CALIFORNIA DEPARTMENT INSTRUCTIONS	NUMBER DI 55.27	DEPARTMENT Water Department
SUBJECT FIRE HYDRANT METER PROGRAM (FORMERLY: CONSTRUCTION METER PROGRAM)	PAGE 9 OF 10	EFFECTIVE DATE October 15, 2002
	SUPERSEDES DI 55.27	DATED April 21, 2000

7. FEE AND DEPOSIT SCHEDULES

7.1 **Fees and Deposit Schedules:** The fees and deposits, as listed in the Rate Book of Fees and Charges, on file with the Office of the City Clerk, are based on actual reimbursement of costs of services performed, equipment and materials. These deposits and fees will be amended, as needed, based on actual costs. Deposits, will be refunded at the end of the use of the fire hydrant meter, upon return of equipment in good working condition and all outstanding balances on account are paid. Deposits can also be used to cover outstanding balances.

All fees for equipment, installation, testing, relocation and other costs related to this program are subject to change without prior notification. The Mayor and Council will be notified of any future changes.

8. UNAUTHORIZED USE OF WATER FROM A HYDRANT

8.1 Use of water from any fire hydrant without a properly issued and installed fire hydrant meter is theft of City property. Customers who use water for unauthorized purposes or without a City of San Diego issued meter will be prosecuted.

8.2 If any unauthorized connection, disconnection or relocation of a fire hydrant meter, or other connection device is made by anyone other than authorized Water Department personnel, the person making the connection will be prosecuted for a violation of San Diego Municipal Code, Section 67.15. In the case of a second offense, the customer's fire hydrant meter shall be confiscated and/or the deposit will be forfeited.

8.3 Unauthorized water use shall be billed to the responsible party. Water use charges shall be based on meter readings, or estimates when meter readings are not available.

8.4 In case of unauthorized water use, the customer shall be billed for all applicable charges as if proper authorization for the water use had been obtained, including but not limited to bi-monthly service charges, installation charges and removal charges.

CITY OF SAN DIEGO CALIFORNIA DEPARTMENT INSTRUCTIONS	NUMBER DI 55.27	DEPARTMENT Water Department
SUBJECT FIRE HYDRANT METER PROGRAM (FORMERLY: CONSTRUCTION METER PROGRAM)	PAGE 10 OF 10	EFFECTIVE DATE October 15, 2002
	SUPERSEDES DI 55.27	DATED April 21, 2000

- 8.5 If damage occurs to Water Department property (i.e. fire hydrant meter, backflow, various appurtenances), the cost of repairs or replacements will be charged to the customer of record (applicant).

Water Department Director

- Tabs: 1. Fire Hydrant Meter Application
2. Construction & Maintenance Related Activities With No Return To Sewer
3. Notice of Discontinuation of Service

APPENDIX

Administering Division: Customer Support Division

Subject Index: Construction Meters
Fire Hydrant
Fire Hydrant Meter Program
Meters, Floating or Vehicle Mounted
Mobile Meter
Program, Fire Hydrant Meter

Distribution: DI Manual Holders



Application for Fire Hydrant Meter (EXHIBIT A)

(For Office Use Only)

NS REQ	FAC#
DATE	BY

METER SHOP (619) 527-7449

Meter Information

Application Date	Requested Install Date:
------------------	-------------------------

Fire Hydrant Location: (Attach Detailed Map//Thomas Bros. Map Location or Construction drawing.) Zip:	T.B.	G.B. (CITY USE)
Specific Use of Water:		
Any Return to Sewer or Storm Drain, If so, explain:		
Estimated Duration of Meter Use:		<input type="checkbox"/> Check Box if Reclaimed Water

Company Information

Company Name:			
Mailing Address:			
City:	State:	Zip:	Phone: ()
*Business license#		*Contractor license#	
A Copy of the Contractor's license OR Business License is required at the time of meter issuance.			
Name and Title of Billing Agent: <small>(PERSON IN ACCOUNTS PAYABLE)</small>			Phone: ()
Site Contact Name and Title:			Phone: ()
Responsible Party Name:			Title:
Cal ID#			Phone: ()
Signature:		Date:	
Guarantees Payment of all Charges Resulting from the use of this Meter. Insures that employees of this Organization understand the proper use of fire Hydrant Meter			

Fire Hydrant Meter Removal Request	Requested Removal Date:	
Provide Current Meter Location if Different from Above:		
Signature:	Title:	Date:
Phone: ()	Pager: ()	

<input type="checkbox"/> City Meter	<input type="checkbox"/> Private Meter	
Contract Acct #:	Deposit Amount: \$ 936.00	Fees Amount: \$ 62.00
Meter Serial #	Meter Size: 05	Meter Make and Style: 6-7
Backflow #	Backflow Size:	Backflow Make and Style:
Name:	Signature:	Date:

WATER USES WITHOUT ANTICIPATED CHARGES FOR RETURN TO SEWER

Auto Detailing
Backfilling
Combination Cleaners (Vactors)
Compaction
Concrete Cutters
Construction Trailers
Cross Connection Testing
Dust Control
Flushing Water Mains
Hydro Blasting
Hydro Seeing
Irrigation (for establishing irrigation only; not continuing irrigation)
Mixing Concrete
Mobile Car Washing
Special Events
Street Sweeping
Water Tanks
Water Trucks
Window Washing

Note:

1. If there is any return to sewer or storm drain, then sewer and/or storm drain fees will be charges.

Date

Name of Responsible Party
Company Name and Address
Account Number: _____

Subject: Discontinuation of Fire Hydrant Meter Service

Dear Water Department Customer:

The authorization for use of Fire Hydrant Meter # _____, located at *(Meter Location Address)* ends in 60 days and will be removed on or after *(Date Authorization Expires)*. Extension requests for an additional 90 days must be submitted in writing for consideration 30 days prior to the discontinuation date. If you require an extension, please contact the Water Department, or mail your request for an extension to:

City of San Diego
Water Department
Attention: Meter Services
2797 Caminito Chollas
San Diego, CA 92105-5097

Should you have any questions regarding this matter, please call the Fire Hydrant Hotline at (619) _____ - _____.

Sincerely,

Water Department

APPENDIX C

MATERIALS TYPICALLY ACCEPTED BY CERTIFICATE OF COMPLIANCE

Materials Typically Accepted by Certificate of Compliance

1. Soil amendment
2. Fiber mulch
3. PVC or PE pipe up to 16 inch diameter
4. Stabilizing emulsion
5. Lime
6. Preformed elastomeric joint seal
7. Plain and fabric reinforced elastomeric bearing pads
8. Steel reinforced elastomeric bearing pads
9. Waterstops (Special Condition)
10. Epoxy coated bar reinforcement
11. Plain and reinforcing steel
12. Structural steel
13. Structural timber and lumber
14. Treated timber and lumber
15. Lumber and timber
16. Aluminum pipe and aluminum pipe arch
17. Corrugated steel pipe and corrugated steel pipe arch
18. Structural metal plate pipe arches and pipe arches
19. Perforated steel pipe
20. Aluminum underdrain pipe
21. Aluminum or steel entrance tapers, pipe downdrains, reducers, coupling bands and slip joints
22. Metal target plates
23. Paint (traffic striping)
24. Conductors
25. Painting of electrical equipment
26. Electrical components
27. Engineering fabric
28. Portland Cement
29. PCC admixtures
30. Minor concrete, asphalt
31. Asphalt (oil)
32. Liquid asphalt emulsion
33. Epoxy

APPENDIX D
SAMPLE CITY INVOICE

APPENDIX E
VICINITY MAP

Trail For All People

Vicinity Map

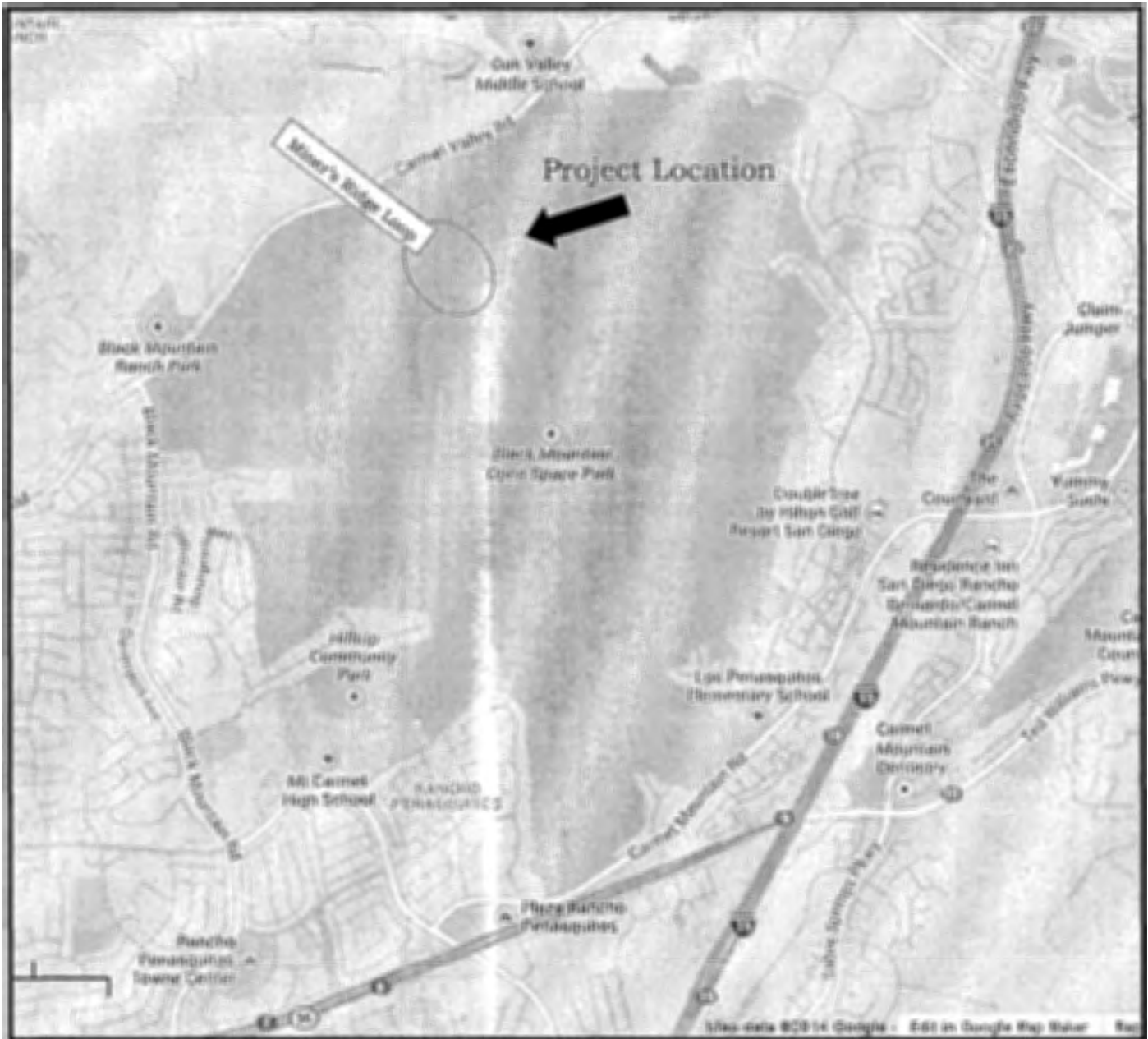

APPENDIX F
SAMPLE OF PUBLIC NOTICES



PROJECT NAME

Trenching on your street is complete.

What you need to know:

- Pipe installation on your street is complete and construction crews are now installing new pipeline for this project at another location.
- You may see temporary trench plates or trench cap for some time, even after construction activities have concluded on your street.

Street resurfacing:

- Your Streets will be resurfaced once the entire pipeline project is complete. Concrete streets will not be resurfaced curb to curb; only the trench will be backfilled.
- Street resurfacing may be delayed due the City's slurry seal moratorium

Estimated resurfacing completion on your street:

(Insert Date-Month and Year)

For questions related to this work

Call: (619) 533-4207

Email: engineering@sandiego.gov



This information is available in alternative formats upon request.



ATTACHMENT F
INTENTIONALLY LEFT BLANK

City of San Diego

CITY CONTACT: Clementina Giordano, Contract Specialist, Email: CGiordano@saniego.gov.
Phone No. (619) 533-3481, Fax No. (619) 533-3633

ADDENDUM "A"

FOR

TRAIL FOR ALL PEOPLE



BID NO.:	<u>L-16-1240-DBB-1</u>
SAP NO. (WBS/IO/CC):	<u>S-13001</u>
CLIENT DEPARTMENT:	<u>1714</u>
COUNCIL DISTRICT:	<u>5</u>
PROJECT TYPE:	<u>GD</u>

BID DUE DATE:

1:30 PM
SEPTEMBER 2, 2015
CITY OF SAN DIEGO
PUBLIC WORKS CONTRACTS
1010 SECOND AVENUE, 14th FLOOR, MS 614C
SAN DIEGO, CA 92101

ENGINEER OF WORK

The engineering Specifications and Special Provisions contained herein have been prepared by or under the direction of the following Registered Engineer:

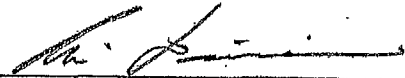

For City Engineer

8/20/15
Date

Seal:

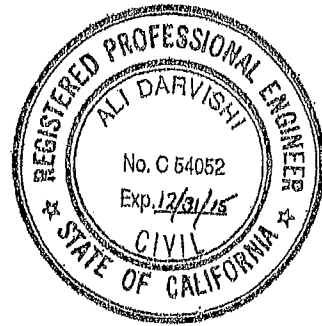

A. CHANGES TO CONTRACT DOCUMENTS

The following changes to the Contract Documents are hereby made effective as though originally issued with the bid package. Bidders are reminded that all previous requirements to this solicitation remain in full force and effect.

B. VOLUME 1

1. To Notice Inviting Bids, Item 31, Required Document Schedule, Page 14, to Required Document Schedule table, **ADD** the following:

16.	WITHIN 3 WORKING DAYS OF THE BID OPENING DATE	THREE APPARENT LOW BIDDERS	Biologist's Experience and Past Project Documentation. See section 700.
-----	---	----------------------------	---

2. To Attachment E, Supplementary Special Provisions, Section 700, Extended Revegetation, Maintenance, and Monitoring, Subsection 700-1.7.2, Project Biologist, Page 45, **ADD** the following:

Within 3 Working Days of the Bid opening date, the three apparent low bidders are to submit copies of the following:

- The Biologist's qualifications as noted in 700-1.1
- The Biologist's Experience; past project documentation of at least 1 successfully completed project of similar size and complexity in Southern California

C. PLANS

1. To Drawings numbered 37860-1-D, 37860-2-D, 37860-3-D, 37860-6-D, 37860-7-D, **DELETE** in their entirety and **REPLACE** with pages 4 through 8 of this Addendum.

James Nagelvoort, Director
Public Works Department

Dated: *August 20, 2015*
San Diego, California

JN/RWB/egz

IMPROVEMENT PLANS FOR: TRAIL FOR ALL PEOPLE (BLACK MOUNTAIN OPEN SPACE PARK)

GENERAL NOTES

1. GENERAL NOTES SHALL BE READ BY THE CITY ENGINEER AND THE CONTRACTOR AND SHALL BE REPRODUCED IN THE CONTRACT DOCUMENTS.
2. THE PURPOSE OF THESE PLANS IS TO PROVIDE A TRAIL FOR ALL PEOPLE THROUGH THE BLACK MOUNTAIN OPEN SPACE PARK. THE TRAIL SHALL BE LOCATED AS SHOWN ON THESE PLANS AND SHALL BE CONSTRUCTED IN ACCORDANCE WITH THE CITY ENGINEER'S AND THE CONTRACTOR'S AGREEMENT.
3. THE CONTRACTOR SHALL BE RESPONSIBLE FOR OBTAINING ALL NECESSARY PERMITS AND APPROVALS FROM THE CITY ENGINEER AND THE CITY COUNCIL. THE CONTRACTOR SHALL ALSO BE RESPONSIBLE FOR OBTAINING ALL NECESSARY PERMITS AND APPROVALS FROM THE CALIFORNIA DEPARTMENT OF TRANSPORTATION AND THE CALIFORNIA DEPARTMENT OF INDUSTRIAL RELATIONS.
4. ALL WORK SHALL BE DONE IN ACCORDANCE WITH THE CITY ENGINEER'S AND THE CONTRACTOR'S AGREEMENT. THE CONTRACTOR SHALL BE RESPONSIBLE FOR OBTAINING ALL NECESSARY PERMITS AND APPROVALS FROM THE CITY ENGINEER AND THE CITY COUNCIL.
5. THE CONTRACTOR SHALL BE RESPONSIBLE FOR OBTAINING ALL NECESSARY PERMITS AND APPROVALS FROM THE CITY ENGINEER AND THE CITY COUNCIL. THE CONTRACTOR SHALL ALSO BE RESPONSIBLE FOR OBTAINING ALL NECESSARY PERMITS AND APPROVALS FROM THE CALIFORNIA DEPARTMENT OF TRANSPORTATION AND THE CALIFORNIA DEPARTMENT OF INDUSTRIAL RELATIONS.
6. THE CONTRACTOR SHALL BE RESPONSIBLE FOR OBTAINING ALL NECESSARY PERMITS AND APPROVALS FROM THE CITY ENGINEER AND THE CITY COUNCIL. THE CONTRACTOR SHALL ALSO BE RESPONSIBLE FOR OBTAINING ALL NECESSARY PERMITS AND APPROVALS FROM THE CALIFORNIA DEPARTMENT OF TRANSPORTATION AND THE CALIFORNIA DEPARTMENT OF INDUSTRIAL RELATIONS.
7. THE CONTRACTOR SHALL BE RESPONSIBLE FOR OBTAINING ALL NECESSARY PERMITS AND APPROVALS FROM THE CITY ENGINEER AND THE CITY COUNCIL. THE CONTRACTOR SHALL ALSO BE RESPONSIBLE FOR OBTAINING ALL NECESSARY PERMITS AND APPROVALS FROM THE CALIFORNIA DEPARTMENT OF TRANSPORTATION AND THE CALIFORNIA DEPARTMENT OF INDUSTRIAL RELATIONS.
8. THE CONTRACTOR SHALL BE RESPONSIBLE FOR OBTAINING ALL NECESSARY PERMITS AND APPROVALS FROM THE CITY ENGINEER AND THE CITY COUNCIL. THE CONTRACTOR SHALL ALSO BE RESPONSIBLE FOR OBTAINING ALL NECESSARY PERMITS AND APPROVALS FROM THE CALIFORNIA DEPARTMENT OF TRANSPORTATION AND THE CALIFORNIA DEPARTMENT OF INDUSTRIAL RELATIONS.
9. THE CONTRACTOR SHALL BE RESPONSIBLE FOR OBTAINING ALL NECESSARY PERMITS AND APPROVALS FROM THE CITY ENGINEER AND THE CITY COUNCIL. THE CONTRACTOR SHALL ALSO BE RESPONSIBLE FOR OBTAINING ALL NECESSARY PERMITS AND APPROVALS FROM THE CALIFORNIA DEPARTMENT OF TRANSPORTATION AND THE CALIFORNIA DEPARTMENT OF INDUSTRIAL RELATIONS.
10. THE CONTRACTOR SHALL BE RESPONSIBLE FOR OBTAINING ALL NECESSARY PERMITS AND APPROVALS FROM THE CITY ENGINEER AND THE CITY COUNCIL. THE CONTRACTOR SHALL ALSO BE RESPONSIBLE FOR OBTAINING ALL NECESSARY PERMITS AND APPROVALS FROM THE CALIFORNIA DEPARTMENT OF TRANSPORTATION AND THE CALIFORNIA DEPARTMENT OF INDUSTRIAL RELATIONS.

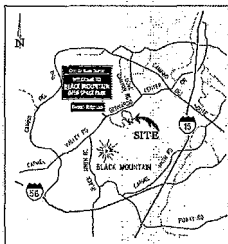

OWNER / APPLICANT

CITY OF SAN DIEGO
PUBLIC WORKS DEPARTMENT / OPEN SPACE DIVISION
300 N. STREET, 3RD FLOOR
SAN DIEGO, CALIFORNIA 92101
619-441-1000

SOURCE OF TOPOGRAPHY

USDA 2.5' X 3" QUAD, T4S, R10E, S12E, SECTION 11, T4S, R10E, S12E, SAN DIEGO COUNTY, CALIFORNIA, 1984.

BENCH MARK

NEAREST BENCH MARK: 100' BENCH MARK
ELEVATION: 100.00'

SHEET INDEX

THIS SHEET IS ONE OF SEVERAL SHEETS THAT MAKE UP THE COMPLETE SET OF PLANS FOR THIS PROJECT. THE COMPLETE SET OF PLANS IS AVAILABLE FROM THE CITY ENGINEER'S OFFICE.

EARTHWORK

EXCAVATION AND RECONSTRUCTION SHALL BE DONE IN ACCORDANCE WITH THE CITY ENGINEER'S AND THE CONTRACTOR'S AGREEMENT.

TRAFFIC CONTROL NOTES

FOR WORK ON OR ADJACENT TO PUBLIC ROAD OPEN TO TRAFFIC:
THE CONTRACTOR SHALL SUBMIT A TRAFFIC CONTROL PLAN TO THE CITY ENGINEER FOR APPROVAL. THE TRAFFIC CONTROL PLAN SHALL INCLUDE A TRAFFIC CONTROL PLAN, A TRAFFIC CONTROL PLAN, AND A TRAFFIC CONTROL PLAN. THE TRAFFIC CONTROL PLAN SHALL BE APPROVED BY THE CITY ENGINEER AND THE CITY COUNCIL.

PARK CONSTRUCTION INSPECTION STAGES AND INSPECTION TEAM

- PARK CONSTRUCTION TEAM:
1. SITE SUPERVISOR
 2. PROJECT ENGINEER FROM FIELD ENGINEERING DEPARTMENT
 3. CITY PROJECT MANAGER
 4. DESIGN CONSULTANT
 5. PARK AND RECREATION DISTRICT MANAGER

PARK CONSTRUCTION INSPECTION STAGES

1. PRE-CONSTRUCTION MEETING
2. DESIGN REVIEW AND APPROVAL
3. PROGRESS AT END OF EACH STAGE AND 1 MONTH BEFORE COMPLETION AND FINAL INSPECTION
4. FINAL INSPECTION AND APPROVAL
5. FINAL INSPECTION AND APPROVAL
6. FINAL INSPECTION AND APPROVAL

DECLARATION OF RESPONSIBLE CHARGE

I, the undersigned, declare that I am the responsible charge engineer for the design and construction of the project shown on these plans. I am a duly licensed professional engineer in the State of California, No. 10000, and I am the author of the design and construction of the project shown on these plans. I am responsible for the design and construction of the project shown on these plans.

WALTER S. WILLY
REGISTERED PROFESSIONAL ENGINEER
NO. 10000
STATE OF CALIFORNIA

CONTRACTOR USE ONLY: RICK CONSULTANTS, INC. 10000 RICK BLVD., SAN DIEGO, CA 92108

CONSULTANT

RICK CONSULTANTS, INC.
10000 RICK BLVD., SAN DIEGO, CA 92108
619-441-1000
WWW.RICKCONSULTANTS.COM

CHANGE NO.	DATE	AFFECTED SHEET NUMBER(S)	APPROVAL NO.
1	05-15-10	V, S, E, A, AND T	

APPROVED BY:
CITY OF SAN DIEGO
PUBLIC WORKS PROJECT

CITY OF SAN DIEGO
PUBLIC WORKS PROJECT



PLANS FOR THE CONSTRUCTION OF TRAIL FOR ALL PEOPLE (BLACK MOUNTAIN OPEN SPACE PARK)			
PROJECT NO.	10000	CITY OF SAN DIEGO, CALIFORNIA	DATE: 05/15/10
PROJECT NAME	TRAIL FOR ALL PEOPLE	PUBLIC WORKS DEPARTMENT	SCALE: AS SHOWN
PROJECT LOCATION	BLACK MOUNTAIN OPEN SPACE PARK	NO. 10000 RICK BLVD.	PROJECT NO.: 10000
PROJECT ENGINEER	WALTER S. WILLY	REGISTERED PROFESSIONAL ENGINEER	NO. 10000
PROJECT MANAGER			
PROJECT DESIGNER			
PROJECT CHECKER			
PROJECT APPROVER			
PROJECT DATE	05/15/10		
PROJECT STATUS	FOR CONSTRUCTION		
PROJECT NO.	10000		

TRAIL FOR ALL PEOPLE

CONSTRUCTION NOTES

1. ALL CONSTRUCTION SHALL BE IN ACCORDANCE WITH THE CITY OF SAN DIEGO SPECIFICATIONS FOR CONSTRUCTION OF OPEN SPACE PARKS...

REVEGETATION NOTES

1. ALL REVEGETATION SHALL BE IN ACCORDANCE WITH THE CITY OF SAN DIEGO SPECIFICATIONS FOR CONSTRUCTION OF OPEN SPACE PARKS...

EROSION AND SEDIMENT CONTROL NOTES

1. ALL EROSION AND SEDIMENT CONTROL MEASURES SHALL BE IN ACCORDANCE WITH THE CITY OF SAN DIEGO SPECIFICATIONS FOR CONSTRUCTION OF OPEN SPACE PARKS...

STORM WATER PROTECTION

1. ALL STORM WATER PROTECTION MEASURES SHALL BE IN ACCORDANCE WITH THE CITY OF SAN DIEGO SPECIFICATIONS FOR CONSTRUCTION OF OPEN SPACE PARKS...

MINIMUM POST-CONSTRUCTION MAINTENANCE PLAN

1. THE POST-CONSTRUCTION MAINTENANCE PLAN SHALL BE IN ACCORDANCE WITH THE CITY OF SAN DIEGO SPECIFICATIONS FOR CONSTRUCTION OF OPEN SPACE PARKS...

CONTRACTOR'S RESPONSIBILITIES

1. THE CONTRACTOR SHALL BE RESPONSIBLE FOR OBTAINING ALL NECESSARY PERMITS AND APPROVALS FROM THE CITY OF SAN DIEGO...

ENVIRONMENTAL/MITIGATION REQUIREMENTS

1. THE CONTRACTOR SHALL BE RESPONSIBLE FOR OBTAINING ALL NECESSARY PERMITS AND APPROVALS FROM THE CITY OF SAN DIEGO...

SEED MIX

Table with columns: Scientific Name, Common Name, Use of Seed (PLS/LB), Minimum PLS/LB. Lists various grass and legume species.

ABBREVIATIONS

Table with columns: Abbreviation, Full Name. Lists various construction and surveying abbreviations.

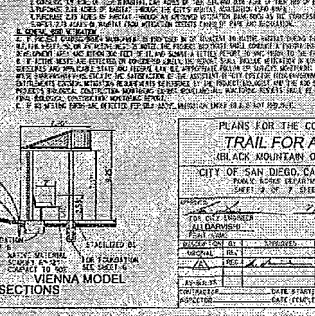
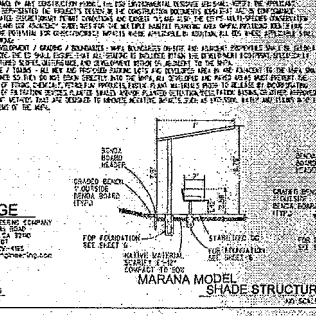
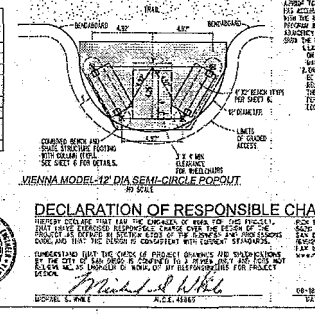
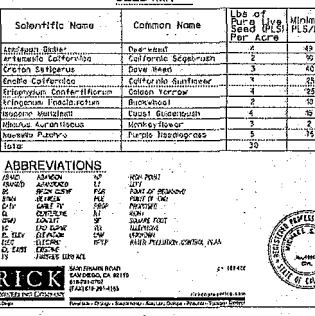

DECLARATION OF RESPONSIBLE CHARGE. I, the undersigned, hereby certify that I am the duly licensed Professional Engineer in the State of California...

DECLARATION OF RESPONSIBLE CHARGE. I, the undersigned, hereby certify that I am the duly licensed Professional Engineer in the State of California...

DECLARATION OF RESPONSIBLE CHARGE. I, the undersigned, hereby certify that I am the duly licensed Professional Engineer in the State of California...

DECLARATION OF RESPONSIBLE CHARGE. I, the undersigned, hereby certify that I am the duly licensed Professional Engineer in the State of California...

PLANS FOR THE CONSTRUCTION OF TRAIL FOR ALL PEOPLE. CITY OF SAN DIEGO, CALIFORNIA. Includes project name, location, and drawing number.

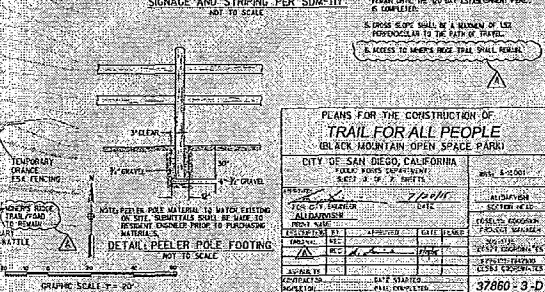
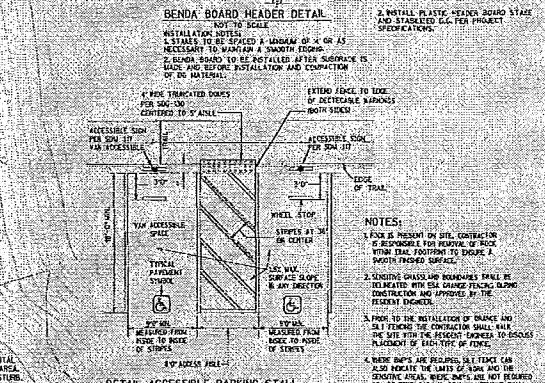
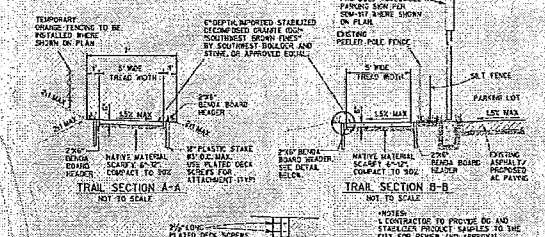
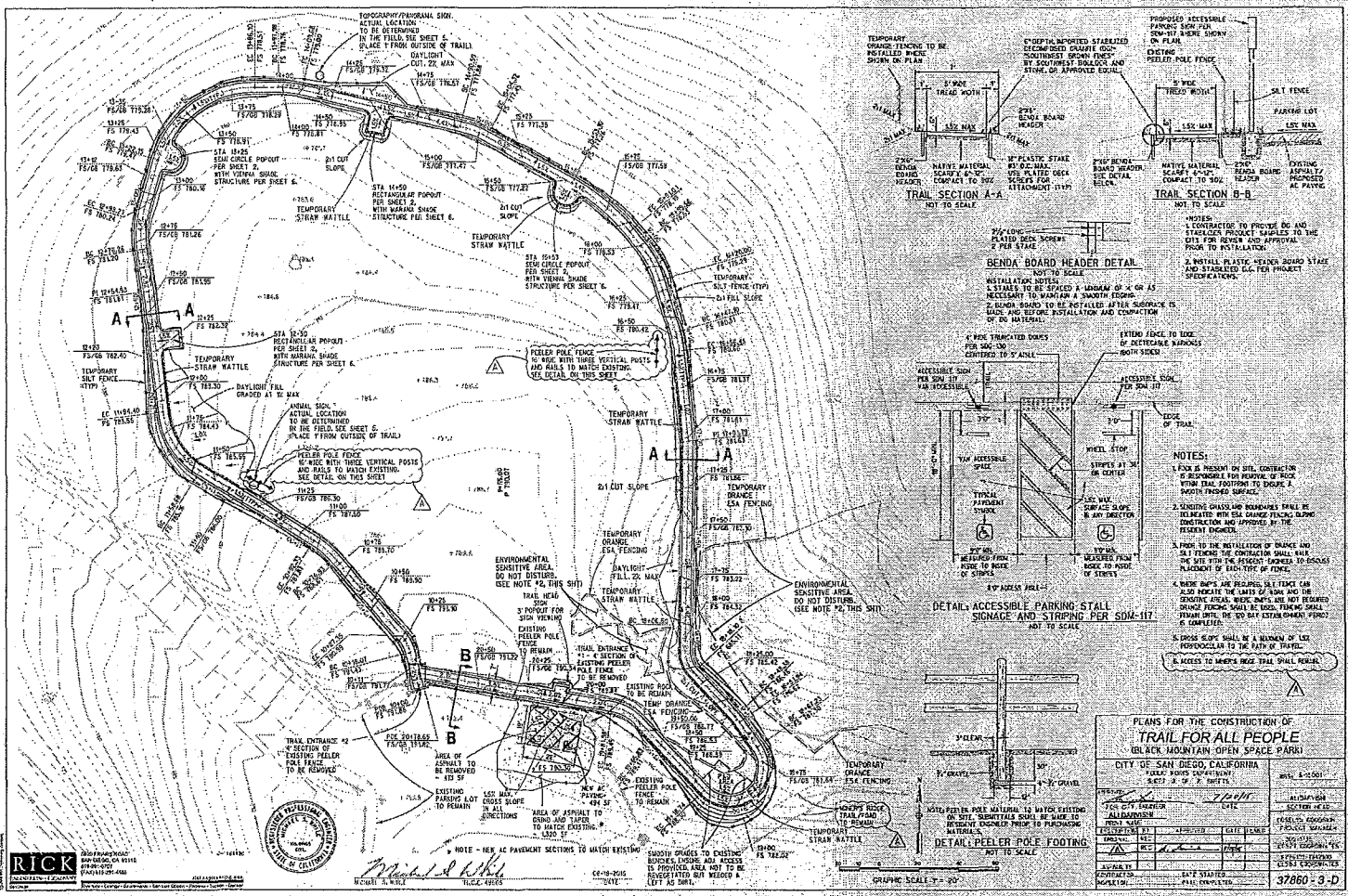

PLANS FOR THE CONSTRUCTION OF
TRAIL FOR ALL PEOPLE
GILCHRIST MOUNTAIN OPEN SPACE PARK

CITY OF SAN DIEGO, CALIFORNIA
15450 LA JOLLA VILLAGE CENTER DRIVE
SAN DIEGO, CA 92131

NO.	DATE	BY	FOR	REVISION
1	12/11/11	W. J. WILKINS	W. J. WILKINS	ISSUED FOR PERMITS
2	01/10/12	W. J. WILKINS	W. J. WILKINS	ISSUED FOR PERMITS
3	02/01/12	W. J. WILKINS	W. J. WILKINS	ISSUED FOR PERMITS
4	02/01/12	W. J. WILKINS	W. J. WILKINS	ISSUED FOR PERMITS
5	02/01/12	W. J. WILKINS	W. J. WILKINS	ISSUED FOR PERMITS
6	02/01/12	W. J. WILKINS	W. J. WILKINS	ISSUED FOR PERMITS
7	02/01/12	W. J. WILKINS	W. J. WILKINS	ISSUED FOR PERMITS
8	02/01/12	W. J. WILKINS	W. J. WILKINS	ISSUED FOR PERMITS
9	02/01/12	W. J. WILKINS	W. J. WILKINS	ISSUED FOR PERMITS
10	02/01/12	W. J. WILKINS	W. J. WILKINS	ISSUED FOR PERMITS
11	02/01/12	W. J. WILKINS	W. J. WILKINS	ISSUED FOR PERMITS
12	02/01/12	W. J. WILKINS	W. J. WILKINS	ISSUED FOR PERMITS
13	02/01/12	W. J. WILKINS	W. J. WILKINS	ISSUED FOR PERMITS
14	02/01/12	W. J. WILKINS	W. J. WILKINS	ISSUED FOR PERMITS
15	02/01/12	W. J. WILKINS	W. J. WILKINS	ISSUED FOR PERMITS
16	02/01/12	W. J. WILKINS	W. J. WILKINS	ISSUED FOR PERMITS
17	02/01/12	W. J. WILKINS	W. J. WILKINS	ISSUED FOR PERMITS
18	02/01/12	W. J. WILKINS	W. J. WILKINS	ISSUED FOR PERMITS
19	02/01/12	W. J. WILKINS	W. J. WILKINS	ISSUED FOR PERMITS
20	02/01/12	W. J. WILKINS	W. J. WILKINS	ISSUED FOR PERMITS
21	02/01/12	W. J. WILKINS	W. J. WILKINS	ISSUED FOR PERMITS
22	02/01/12	W. J. WILKINS	W. J. WILKINS	ISSUED FOR PERMITS
23	02/01/12	W. J. WILKINS	W. J. WILKINS	ISSUED FOR PERMITS
24	02/01/12	W. J. WILKINS	W. J. WILKINS	ISSUED FOR PERMITS
25	02/01/12	W. J. WILKINS	W. J. WILKINS	ISSUED FOR PERMITS
26	02/01/12	W. J. WILKINS	W. J. WILKINS	ISSUED FOR PERMITS
27	02/01/12	W. J. WILKINS	W. J. WILKINS	ISSUED FOR PERMITS
28	02/01/12	W. J. WILKINS	W. J. WILKINS	ISSUED FOR PERMITS
29	02/01/12	W. J. WILKINS	W. J. WILKINS	ISSUED FOR PERMITS
30	02/01/12	W. J. WILKINS	W. J. WILKINS	ISSUED FOR PERMITS
31	02/01/12	W. J. WILKINS	W. J. WILKINS	ISSUED FOR PERMITS
32	02/01/12	W. J. WILKINS	W. J. WILKINS	ISSUED FOR PERMITS
33	02/01/12	W. J. WILKINS	W. J. WILKINS	ISSUED FOR PERMITS
34	02/01/12	W. J. WILKINS	W. J. WILKINS	ISSUED FOR PERMITS
35	02/01/12	W. J. WILKINS	W. J. WILKINS	ISSUED FOR PERMITS
36	02/01/12	W. J. WILKINS	W. J. WILKINS	ISSUED FOR PERMITS
37	02/01/12	W. J. WILKINS	W. J. WILKINS	ISSUED FOR PERMITS
38	02/01/12	W. J. WILKINS	W. J. WILKINS	ISSUED FOR PERMITS
39	02/01/12	W. J. WILKINS	W. J. WILKINS	ISSUED FOR PERMITS
40	02/01/12	W. J. WILKINS	W. J. WILKINS	ISSUED FOR PERMITS
41	02/01/12	W. J. WILKINS	W. J. WILKINS	ISSUED FOR PERMITS
42	02/01/12	W. J. WILKINS	W. J. WILKINS	ISSUED FOR PERMITS
43	02/01/12	W. J. WILKINS	W. J. WILKINS	ISSUED FOR PERMITS
44	02/01/12	W. J. WILKINS	W. J. WILKINS	ISSUED FOR PERMITS
45	02/01/12	W. J. WILKINS	W. J. WILKINS	ISSUED FOR PERMITS
46	02/01/12	W. J. WILKINS	W. J. WILKINS	ISSUED FOR PERMITS
47	02/01/12	W. J. WILKINS	W. J. WILKINS	ISSUED FOR PERMITS
48	02/01/12	W. J. WILKINS	W. J. WILKINS	ISSUED FOR PERMITS
49	02/01/12	W. J. WILKINS	W. J. WILKINS	ISSUED FOR PERMITS
50	02/01/12	W. J. WILKINS	W. J. WILKINS	ISSUED FOR PERMITS

37880-3-D

RICK
REGISTERED PROFESSIONAL ENGINEER
CITY OF SAN DIEGO, CALIFORNIA
15450 LA JOLLA VILLAGE CENTER DRIVE
SAN DIEGO, CA 92131
TEL: 619-594-8800
FAX: 619-594-8801
WWW.RICKENGINEERS.COM

W. J. WILKINS
REGISTERED PROFESSIONAL ENGINEER
CITY OF SAN DIEGO, CALIFORNIA
15450 LA JOLLA VILLAGE CENTER DRIVE
SAN DIEGO, CA 92131
TEL: 619-594-8800
FAX: 619-594-8801
WWW.RICKENGINEERS.COM

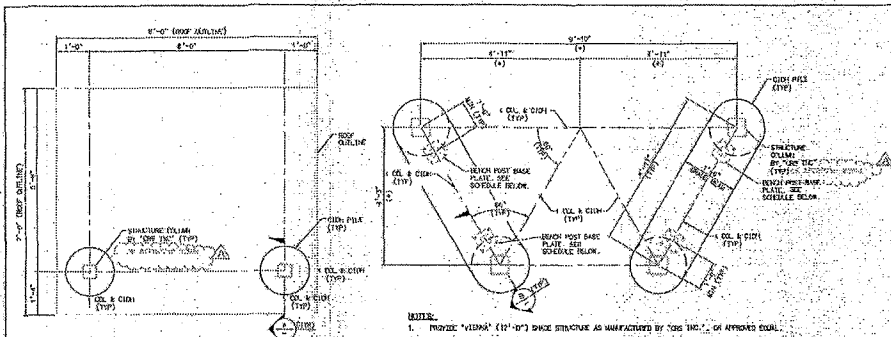

VIENNA SHADE STRUCTURE - FOUNDATION PLAN
SCALE: 3/4" = 1'-0"

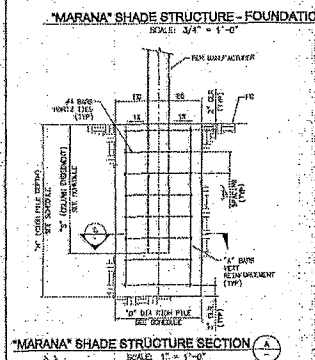

MARANA SHADE STRUCTURE SECTION A
SCALE: 1/2" = 1'-0"

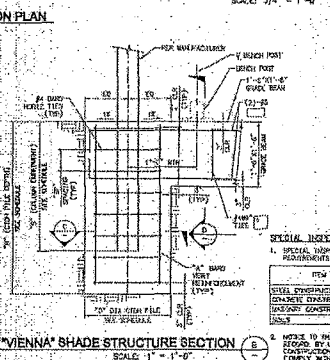

VIENNA SHADE STRUCTURE SECTION B
SCALE: 1" = 1'-0"

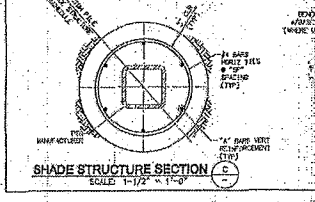

SHADE STRUCTURE SECTION C
SCALE: 1/2" = 1'-0"

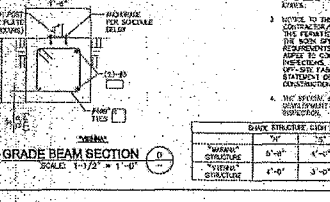

GRADE BEAM SECTION D
SCALE: 1/2" = 1'-0"

SECTION	WIDTH	HEIGHT	REINFORCEMENT	CONCRETE
MARANA SHADE STRUCTURE	8'-0"	4'-0"	4" BARS	100-PSI
VIENNA SHADE STRUCTURE	4'-0"	3'-0"	2" BARS	100-PSI

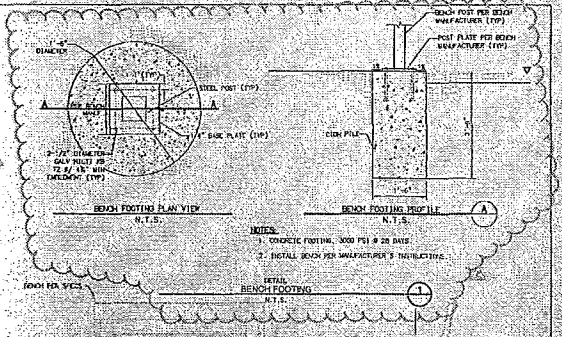

BENCH TYPICAL ELEVATIONS
SCALE: 1" = 1'-0"

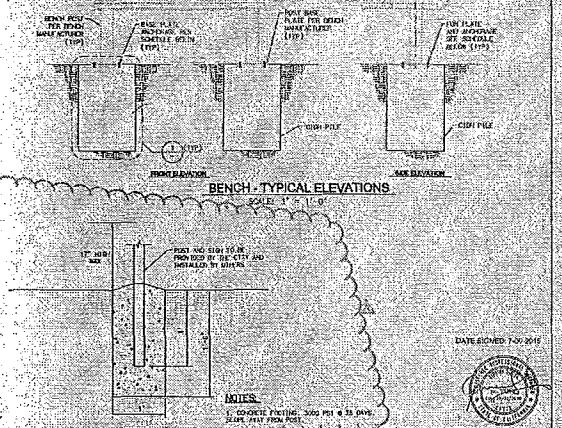

PLANT SIGN FOOTINGS
SCALE: 1" = 1'-0"

PLANS FOR THE CONSTRUCTION OF
TRAIL FOR ALL PEOPLE
SHADE STRUC. PLANT SIGN AND BENCH FOOTING
CITY OF SAN DIEGO, CALIFORNIA
PROJECT NO. 37880-6-D

NO.	DATE	BY	FOR
1	11/11/01
2
3
4
5
6
7
8
9
10

ADDENDUM A

TRAIL FOR ALL PEOPLE

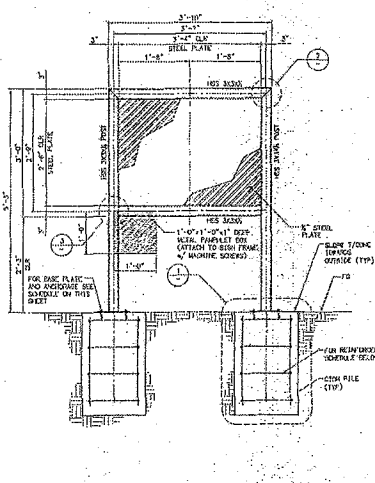

TRAIL HEAD SIGN - TYPICAL ELEVATION
SCALE: 1" = 1'-0"

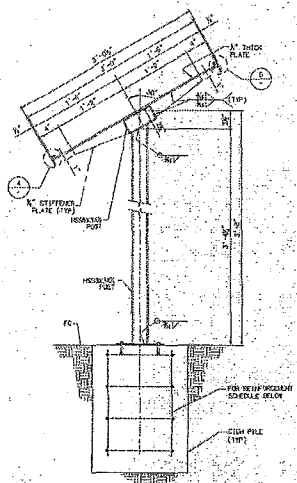

INTERPRETIVE SIGN - TYPICAL ELEVATION

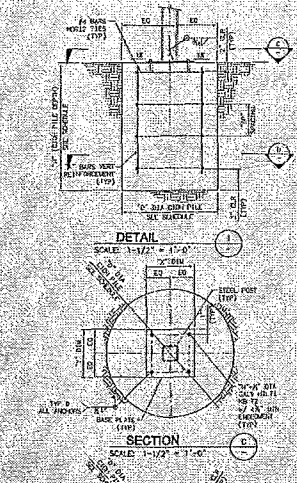
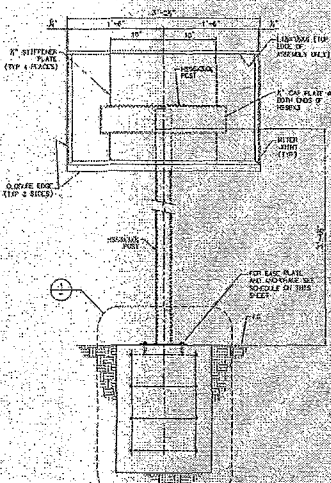

DETAIL
SCALE: 1-1/2" = 1'-0"

SECTION
SCALE: 1-1/2" = 1'-0"

GENERAL NOTES:

- DESIGN CRITERIA:**
1. AS A CALIFORNIA LICENSED ENGINEER, I HAVE CLASSIFIED THE UNDERTHEMENT MATHEMATICS TO BE IN ACCORDANCE WITH THE LATEST EDITIONS OF THE AISC AND AASHTO DESIGN SPECIFICATIONS FOR STEEL AND ALUMINUM STRUCTURES, RESPECTIVELY.
 2. LATERAL LOAD DESIGN CRITERIA SHALL BE IN ACCORDANCE WITH THE LATEST EDITIONS OF THE AISC AND AASHTO DESIGN SPECIFICATIONS, RESPECTIVELY.
 3. WIND LOAD DESIGN CRITERIA SHALL BE IN ACCORDANCE WITH THE LATEST EDITIONS OF THE AISC AND AASHTO DESIGN SPECIFICATIONS, RESPECTIVELY.
 4. SEISMIC DESIGN CRITERIA SHALL BE IN ACCORDANCE WITH THE LATEST EDITIONS OF THE AISC AND AASHTO DESIGN SPECIFICATIONS, RESPECTIVELY.
- REINFORCING STEEL:**
1. REINFORCING STEEL SHALL BE PROVIDED IN ACCORDANCE WITH THE LATEST EDITIONS OF THE AISC AND AASHTO DESIGN SPECIFICATIONS, RESPECTIVELY.
 2. ALL REINFORCING AND MISCELLANEOUS STEEL SHALL BE FABRICATED IN ACCORDANCE WITH THE LATEST EDITIONS OF THE AISC AND AASHTO DESIGN SPECIFICATIONS, RESPECTIVELY.
 3. WELDED STEEL CONNECTIONS SHALL BE IN ACCORDANCE WITH THE LATEST EDITIONS OF THE AISC AND AASHTO DESIGN SPECIFICATIONS, RESPECTIVELY.
 4. ALL WELDS SHALL BE IN ACCORDANCE WITH THE LATEST EDITIONS OF THE AISC AND AASHTO DESIGN SPECIFICATIONS, RESPECTIVELY.
 5. ALL STEEL EXPOSED TO WEATHER SHALL BE SHIP FORMER COATED PINK COLOR SHALL BE 100% AND APPROVED BY A LICENSED PAINTER. CONNECTIONS SHALL BE WELDED TO THE RESISTANT DESIGN FOR WELDING AND APPROVAL.
- CONCRETE:**
1. ALL CONCRETE SHALL HAVE A MINIMUM ULTIMATE COMPRESSIVE STRENGTH OF 3,000 PSI AT 28 DAYS.
 2. PORTLAND CEMENT FOR CONCRETE SHALL BE TYPE I/II CONFORMING TO ASTM C150. THE MAXIMUM WATER/CEMENT RATIO SHALL BE 0.45.
 3. CONCRETE COVER FOR REINFORCING BARS SHALL BE:
 - 4" MINIMUM FOR EXPOSED TO WEATHER.
 - 3" MINIMUM FOR EXPOSED TO WEATHER.
 - 2" MINIMUM FOR EXPOSED TO WEATHER.
 - 1" MINIMUM FOR EXPOSED TO WEATHER.
 4. AGGREGATES SHALL CONFORM TO ASTM C33.
 5. SPECIAL INSPECTION FOR CONCRETE CONSTRUCTION IS REQUIRED.

TRAIL HEAD SIGN AND INTERPRETIVE SIGN CIP# ELEVATION SCHEDULE	1"	2"	3"	4"	5"	6"	7"	8"	9"	10"
TRAIL HEAD SIGN	1	1	1	1	1	1	1	1	1	1
INTERPRETIVE SIGN	1	1	1	1	1	1	1	1	1	1

PLANS FOR THE CONSTRUCTION OF TRAIL FOR ALL PEOPLE
TRAIL HEAD SIGN AND INTERPRETIVE SIGN DETAILS

CITY OF SAN DIEGO, CALIFORNIA
PUBLIC WORKS DEPARTMENT
SHEET 7 OF 7 SHEETS

DATE: 1/20/11
DRAWN BY: J. GARCIA
CHECKED BY: J. GARCIA
APPROVED BY: J. GARCIA

DATE: 1/20/11
DRAWN BY: J. GARCIA
CHECKED BY: J. GARCIA
APPROVED BY: J. GARCIA

PROJECT NO.: 37860-7-D

U.S.V.
L.K.A.V.
①

City of San Diego

CONTRACTOR'S NAME: Blue Pacific Engineering & Construction
ADDRESS: 7330 Opportunity Road, Suite J
TELEPHONE NO.: 858-956-1456 FAX NO.: 619-291-0482
CITY CONTACT: CLEMENTINA GIORDANO, Contract Specialist, Email: Cgiordano@sandiego.gov
Phone No. (619) 533-3481, Fax No. (619) 533-3633
C.Goodrich/RWBustamante/egz

CONTRACT DOCUMENTS

FOR

TRAIL FOR ALL PEOPLE



VOLUME 2 OF 2

BID NO.: L-16-1240-DBB-1
SAP NO. (WBS/IO/CC): S-13001
CLIENT DEPARTMENT: 1714
COUNCIL DISTRICT: 5
PROJECT TYPE: GD

THIS CONTRACT IS SUBJECT TO THE FOLLOWING:

- THE CITY'S SUBCONTRACTING PARTICIPATION REQUIREMENTS FOR SLBE PROGRAM.
- COMPETITION RESTRICTED TO: SLBE-ELBE or ELBE FIRMS ONLY .
- PREVAILING WAGE RATES: STATE FEDERAL
- APPRENTICESHIP

THIS BIDDING DOCUMENT TO BE SUBMITTED IN ITS ENTIRETY REFER TO VOLUME 1 COVER PAGE FOR TIME, DATE, AND LOCATION

TABLE OF CONTENTS

DESCRIPTION

PAGE NUMBER

Volume 2 - Bidding Documents

The following forms must be completed in their entirety and submitted with the Bid. Include the form(s) even if the information does not apply. Where the information does not apply write in N/A. Failure to include any of the forms may cause the Bid to be deemed **non-responsive**. If you are uncertain or have any questions about any required information, contact the City no later than 14 days prior to Bid due date.

1. Bid/Proposal.....	3
2. Non-Collusion Affidavit to be executed by Bidder and Submitted with Bid under 23 USC 112 and PCC 7106	6
3. Contractors Certification of Pending Actions	7
4. Equal Benefits Ordinance Certification of Compliance.....	8
5. Proposal (Bid)	9
6. Form AA35 - List of Subcontractors	12
7. Form AA40 - Named Equipment/Material Supplier List	13

BIDDING DOCUMENTS

PROPOSAL

Bidder's General Information

To the City of San Diego:

Pursuant to "Notice Inviting Bids", specifications, and requirements on file with the City Clerk, and subject to all provisions of the Charter and Ordinances of the City of San Diego and applicable laws and regulations of the United States and the State of California, the undersigned hereby proposes to furnish to the City of San Diego, complete at the prices stated herein, the items or services hereinafter mentioned. The undersigned further warrants that this bid is not made in the interest of, or on behalf of, any undisclosed person, partnership, company, association, organization, or corporation; that the bid is genuine and not collusive or sham; that the bidder has not directly or indirectly induced or solicited any other bidder to put in a false or sham bid, and has not directly or indirectly colluded, conspired, connived, or agreed with any bidder or anyone else to put in a sham bid, or that anyone shall refrain from bidding; that the bidder has not in any manner, directly or indirectly, sought by agreement, communication, or conference with anyone to fix the bid price of the bidder or any other bidder, or to fix any overhead, profit, or cost element of the bid price, or of that of any other bidder, or to secure any advantage against the public body awarding the contract of anyone interested in the proposed contract; that all statements contained in the bid are true; and, further, that the bidder has not, directly or indirectly, submitted his or her bid price or any breakdown thereof, or the contents thereof, or divulged information or data relative thereto, or paid, and will not pay, any fee to any corporation, partnership, company, association, organization, bid depository, or to any member or agent thereof to effectuate a collusive or sham bid.

The undersigned bidder(s) further warrants that bidder(s) has thoroughly examined and understands the entire Contract Documents (plans and specifications) and the Bidding Documents therefore, and that by submitting said Bidding Documents as its bid proposal, bidder(s) acknowledges and is bound by the entire Contract Documents, including any addenda issued thereto, as such Contract Documents incorporated by reference in the Bidding Documents.

IF A SOLE OWNER OR SOLE CONTRACTOR SIGN HERE:

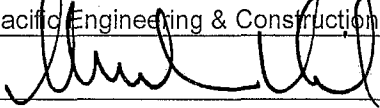
- (1) Name under which business is conducted Blue Pacific Engineering & Construction
- (2) Signature (Given and surname) of proprietor 
- (3) Place of Business (Street & Number) 7330 Opportunity Road, Suite J
- (4) City and State San Diego, CA Zip Code 92111
- (5) Telephone No. 858-956-1456 Facsimile No. 619-291-0482
- (6) Email Address selihu@bluepacificeng.com

IF A PARTNERSHIP, SIGN HERE:

- (1) Name under which business is conducted _____

BIDDING DOCUMENTS

(2) Name of each member of partnership, indicate character of each partner, general or special (limited):

(3) Signature (Note: Signature must be made by a general partner)

Full Name and Character of partner

(4) Place of Business (Street & Number) _____

(5) City and State _____ Zip Code _____

(6) Telephone No. _____ Facsimile No. _____

(7) Email Address _____

IF A CORPORATION, SIGN HERE:

(1) Name under which business is conducted _____

(2) Signature, with official title of officer authorized to sign for the corporation:

(Signature)

(Printed Name)

(Title of Officer)

(Impress Corporate Seal Here)

(3) Incorporated under the laws of the State of _____

(4) Place of Business (Street & Number) _____

(5) City and State _____ Zip Code _____

(6) Telephone No. _____ Facsimile No. _____

(7) Email Address _____

BIDDING DOCUMENTS

THE FOLLOWING SECTIONS MUST BE FILLED IN BY ALL PROPOSERS:

In accordance with the "NOTICE INVITING BIDS", the bidder holds a California State Contractor's license for the following classification(s) to perform the work described in these specifications:

LICENSE CLASSIFICATION A, B, C27, C8, C10

LICENSE NO. 824455 EXPIRES September 30th, 2015

DEPARTMENT OF INDUSTRIAL RELATIONS (DIR) REGISTRATION NUMBER: 1000003217

This license classification must also be shown on the front of the bid envelope. Failure to show license classification on the bid envelope may cause return of the bid unopened.

TAX IDENTIFICATION NUMBER (TIN): [REDACTED]

Email Address: selihu@bluepacificeng.com

THIS PROPOSAL MUST BE NOTARIZED BELOW:

I certify, under penalty of perjury, that the representations made herein regarding my State Contractor's license number, classification and expiration date are true and correct.

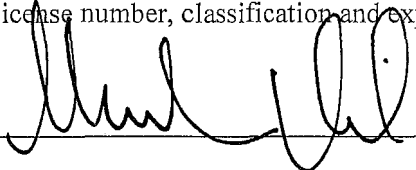
Signature  Title Owner

SUBSCRIBED AND SWORN TO BEFORE ME, THIS _____ DAY OF _____,

Notary Public in and for the County of _____, State of _____

(NOTARIAL SEAL)

attached

NAS SURETY GROUP

NORTH AMERICAN SPECIALTY INSURANCE COMPANY
WASHINGTON INTERNATIONAL INSURANCE COMPANY

GENERAL POWER OF ATTORNEY

KNOW ALL MEN BY THESE PRESENTS, THAT North American Specialty Insurance Company, a corporation duly organized and existing under laws of the State of New Hampshire, and having its principal office in the City of Manchester, New Hampshire, and Washington International Insurance Company, a corporation organized and existing under the laws of the State of New Hampshire and having its principal office in the City of Schaumburg, Illinois, each does hereby make, constitute and appoint:

JOHN G. MALONEY, HELEN MALONEY, MICHELLE M. BASUIL,

GLEND A J. ROONEY, and MARK D. IATAROLA

JOINTLY OR SEVERALLY

Its true and lawful Attorney(s)-in-Fact, to make, execute, seal and deliver, for and on its behalf and as its act and deed, bonds or other writings obligatory in the nature of a bond on behalf of each of said Companies, as surety, on contracts of suretyship as are or may be required or permitted by law, regulation, contract or otherwise, provided that no bond or undertaking or contract or suretyship executed under this authority shall exceed the amount of:

FIFTY MILLION (\$50,000,000.00) DOLLARS

This Power of Attorney is granted and is signed by facsimile under and by the authority of the following Resolutions adopted by the Boards of Directors of both North American Specialty Insurance Company and Washington International Insurance Company at meetings duly called and held on the 9th of May, 2012:

"RESOLVED, that any two of the Presidents, any Managing Director, any Senior Vice President, any Vice President, any Assistant Vice President, the Secretary or any Assistant Secretary be, and each or any of them hereby is authorized to execute a Power of Attorney qualifying the attorney named in the given Power of Attorney to execute on behalf of the Company bonds, undertakings and all contracts of surety, and that each or any of them hereby is authorized to attest to the execution of any such Power of Attorney and to attach therein the seal of the Company; and it is

FURTHER RESOLVED, that the signature of such officers and the seal of the Company may be affixed to any such Power of Attorney or to any certificate relating thereto by facsimile, and any such Power of Attorney or certificate bearing such facsimile signatures or facsimile seal shall be binding upon the Company when so affixed and in the future with regard to any bond, undertaking or contract of surety to which it is attached."



By [Signature] Steven P. Anderson, Senior Vice President of Washington International Insurance Company & Senior Vice President of North American Specialty Insurance Company



By [Signature] David M. Layman, Vice President of Washington International Insurance Company & Vice President of North American Specialty Insurance Company

IN WITNESS WHEREOF, North American Specialty Insurance Company and Washington International Insurance Company have caused their official seals to be hereunto affixed, and these presents to be signed by their authorized officers this 9th day of May, 2014.

North American Specialty Insurance Company
Washington International Insurance Company

State of Illinois
County of Cook ss:

On this 9th day of May, 2014, before me, a Notary Public personally appeared Steven P. Anderson, Senior Vice President of Washington International Insurance Company and Senior Vice President of North American Specialty Insurance Company and David M. Layman, Vice President of Washington International Insurance Company and Vice President of North American Specialty Insurance Company, personally known to me, who being by me duly sworn, acknowledged that they signed the above Power of Attorney as officers of and acknowledged said instrument to be the voluntary act and deed of their respective companies.

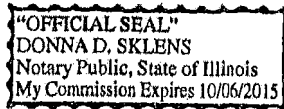

[Signature] Donna D. Sklens, Notary Public

I, Jeffrey Goldberg, the duly elected Assistant Secretary of North American Specialty Insurance Company and Washington International Insurance Company, do hereby certify that the above and foregoing is a true and correct copy of a Power of Attorney given by said North American Specialty Insurance Company and Washington International Insurance Company, which is still in full force and effect.

IN WITNESS WHEREOF, I have set my hand and affixed the seals of the Companies this 1st day of SEPTEMBER, 2015.

[Signature] Jeffrey Goldberg, Vice President & Assistant Secretary of Washington International Insurance Company & North American Specialty Insurance Company

CALIFORNIA ALL PURPOSE ACKNOWLEDGMENT

A notary public or other officer completing this certificate verifies only the identity of the individual who signed the document to which this certificate is attached, and not the truthfulness, accuracy, or validity of that document.

STATE OF CALIFORNIA }

COUNTY OF San Diego }

On Aug 17, 2015 before me, Margarita Amine, Notary Public, Date (here insert name and title of the officer)

personally appeared Shahram elihu

who proved to me on the basis of satisfactory evidence to be the person(s) whose name(s) is/are subscribed to the within instrument and acknowledged to me that he/she/they executed the same in his/her/their authorized capacity(ies), and that by his/her/their signature(s) on the instrument the person(s), or the entity upon behalf of which the person(s) acted, executed the instrument.

I certify under PENALTY OF PERJURY under the laws of the State of California that the foregoing paragraph is true and correct.

WITNESS my hand and official seal.



Signature: Margarita Amine (Seal)

OPTIONAL

Description of Attached Document

Title or Type of Document: Trail for all people Bid Number of Pages:

Document Date: Other:

CALIFORNIA ALL PURPOSE ACKNOWLEDGMENT

A notary public or other officer completing this certificate verifies only the identity of the individual who signed the document to which this certificate is attached, and not the truthfulness, accuracy, or validity of that document.

STATE OF CALIFORNIA }

COUNTY OF San Diego }

On Aug 17, 2015 before me, Margarita Amine Notary Public,

Date

(here insert name and title of the officer)

personally appeared Shahram Elihu

who proved to me on the basis of satisfactory evidence to be the person(s) whose name(s) is/are subscribed to the within instrument and acknowledged to me that he/she/they executed the same in his/her/their authorized capacity(ies), and that by his/her/their signature(s) on the instrument the person(s), or the entity upon behalf of which the person(s) acted, executed the instrument.

I certify under PENALTY OF PERJURY under the laws of the State of California that the foregoing paragraph is true and correct.

WITNESS my hand and official seal.



Signature: Margarita Amine (Seal)

OPTIONAL

Description of Attached Document

Title or Type of Document: Trail for All People NCA Number of Pages: _____

Document Date: _____ Other: _____

BIDDING DOCUMENTS

CONTRACTORS CERTIFICATION OF PENDING ACTIONS

As part of its bid or proposal (Non-Price Proposal in the case of Design-Build contracts), the Bidder shall provide to the City a list of all instances within the past 10 years where a complaint was filed or pending against the Bidder in a legal or administrative proceeding alleging that Bidder discriminated against its employees, subcontractors, vendors or suppliers, and a description of the status or resolution of that complaint, including any remedial action taken.

CHECK ONE BOX ONLY.

- The undersigned certifies that within the past 10 years the Bidder has NOT been the subject of a complaint or pending action in a legal administrative proceeding alleging that Bidder discriminated against its employees, subcontractors, vendors or suppliers.
- The undersigned certifies that within the past 10 years the Bidder has been the subject of a complaint or pending action in a legal administrative proceeding alleging that Bidder discriminated against its employees, subcontractors, vendors or suppliers. A description of the status or resolution of that complaint, including any remedial action taken and the applicable dates is as follows:

DATE OF CLAIM	LOCATION	DESCRIPTION OF CLAIM	LITIGATION (Y/N)	STATUS	RESOLUTION/REMEDIAL ACTION TAKEN

Contractor Name: Blue Pacific Engineering & Construction

Certified By Shahram Elihu Title Owner
Name

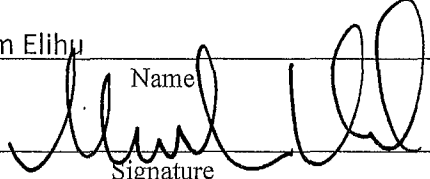
 Date 8/17/15
Signature

USE ADDITIONAL FORMS AS NECESSARY

BIDDING DOCUMENTS

**EQUAL BENEFITS ORDINANCE
CERTIFICATION OF COMPLIANCE**



For additional information, contact:
CITY OF SAN DIEGO
EQUAL BENEFITS PROGRAM
 202 C Street, MS 9A, San Diego, CA 92101
 Phone (619) 533-3948 Fax (619) 533-3220

COMPANY INFORMATION	
Company Name: Blue Pacific Engineering & Construction	Contact Name: Shahram Elihu
Company Address: 7330 Opportunity Road, Suite J, San Diego, CA 92111	Contact Phone: 858-956-1456
	Contact Email: selihu@bluepacificeng.com

CONTRACT INFORMATION	
Contract Title: TRAIL FOR ALL PEOPLE	Start Date: TBD
Contract Number (if no number, state location): L-16-1240-DBB-1	End Date: TBD

SUMMARY OF EQUAL BENEFITS ORDINANCE REQUIREMENTS

The Equal Benefits Ordinance [EBO] requires the City to enter into contracts only with contractors who certify they will provide and maintain equal benefits as defined in SDMC §22.4302 for the duration of the contract. To comply:

- Contractor shall offer equal benefits to employees with spouses and employees with domestic partners.
 - Benefits include health, dental, vision insurance; pension/401(k) plans; bereavement, family, parental leave; discounts, child care; travel/relocation expenses; employee assistance programs; credit union membership; or any other benefit.
 - Any benefit not offer an employee with a spouse, is not required to be offered to an employee with a domestic partner.
- Contractor shall post notice of firm’s equal benefits policy in the workplace and notify employees at time of hire and during open enrollment periods.
- Contractor shall allow City access to records, when requested, to confirm compliance with EBO requirements.
- Contractor shall submit *EBO Certification of Compliance*, signed under penalty of perjury, prior to award of contract.

NOTE: This summary is provided for convenience. Full text of the EBO and Rules Implementing the EBO are available at www.sandiego.gov/administration.

CONTRACTOR EQUAL BENEFITS ORDINANCE CERTIFICATION

Please indicate your firm’s compliance status with the EBO. The City may request supporting documentation.

I affirm **compliance** with the EBO because my firm (*contractor must select one reason*):

- Provides equal benefits to spouses and domestic partners.
- Provides no benefits to spouses or domestic partners.
- Has no employees.
- Has collective bargaining agreement(s) in place prior to January 1, 2011, that has not been renewed or expired.

I request the City’s approval to pay affected employees a cash equivalent in lieu of equal benefits and verify my firm made a reasonable effort but is not able to provide equal benefits upon contract award. I agree to notify employees of the availability of a cash equivalent for benefits available to spouses but not domestic partners and to continue to make every reasonable effort to extend all available benefits to domestic partners.

It is unlawful for any contractor to knowingly submit any false information to the City regarding equal benefits or cash equivalent associated with the execution, award, amendment, or administration of any contract. [San Diego Municipal Code §22.4307(a)]

Under penalty of perjury under laws of the State of California, I certify the above information is true and correct. I further certify that my firm understands the requirements of the Equal Benefits Ordinance and will provide and maintain equal benefits for the duration of the contract or pay a cash equivalent if authorized by the City.

Shahram Elihu, Owner		8/17/15
Name/Title of Signatory	Signature	Date

FOR OFFICIAL CITY USE ONLY		
Receipt Date:	EBO Analyst:	<input type="checkbox"/> Approved <input type="checkbox"/> Not Approved – Reason:

(Rev 02/15/2011)

BIDDING DOCUMENTS

PROPOSAL (BID)

The Bidder agrees to the construction of **Trail For All People**, for the City of San Diego, in accordance with these contract documents for the prices listed below. The Bidder guarantees the Contract Price for a period of 120 days (90 days for federally funded contracts and contracts valued at \$500,000 or less) from the date of Bid opening to Award of the Contract. The duration of the Contract Price guarantee shall be extended by the number of days required for the City to obtain all items necessary to fulfill all conditions precedent e.g., bond and insurance.

Item	Quantity	Unit	NAICS	Payment Reference	Description	Unit Price	Extension
BASE BID							
1.	1	LS	524126	2-4.1	Bonds (Payment and Performance)	 	\$7,500.00
2.	1	AL	236220	7-5.3	Building Permits - Type I	 	\$2,000.00
3.	1	LS	238910	9-3.1	Construction of Trail For All People	 	\$180,000.00
4.	1	AL	236220	9-3.1	Special Inspection - Type I	 	\$3,000.00
5.	1	AL		9-3.5	Field Orders - Type II	 	\$40,000.00
6.	1	LS	541330	701-13.9.5	Water Pollution Control Program Development	 	\$2,000.00
7.	1	LS	237990	701-13.9.5	Water Pollution Control Program Implementation	 	\$4,000.00
ESTIMATED TOTAL BASE BID:							\$238,500

✓
JE

TOTAL BID PRICE FOR BID (Items 1 through 7, inclusive) amount written in words:

Two Hundred Thirty Eight Thousand Five Hundred Dollars

BIDDING DOCUMENTS

The Bid shall contain an acknowledgment of receipt of all addenda, the numbers of which shall be filled in on the Bid form. If an addendum or addenda has been issued by the City and not noted as being received by the Bidder, this proposal shall be rejected as being **non-responsive**. The following addenda have been received and are acknowledged in this bid: A

The names of all persons interested in the foregoing proposal as principals are as follows:

Shahram Elihu, Owner of Blue Pacific Engineering & Construction

IMPORTANT NOTICE: If Bidder or other interested person is a corporation, state secretary, treasurer, and manager thereof; if a co-partnership, state true name of firm, also names of all individual co-partners composing firm; if Bidder or other interested person is an individual, state first and last names in full.

Bidder: Blue Pacific Engineering & Construction

Title: Owner

Business Address: 7330 Opportunity Road, Suite J, San Diego, CA 92111

Place of Business: 7330 Opportunity Road, Suite J, San Diego, CA 92111

Place of Residence: 327 El Pedregal, Solana Beach CA 92075

Signature: 

BIDDING DOCUMENTS

NOTES:

- A. The City shall determine the low Bid based on the Base Bid alone.
- B. Prices and notations shall be in ink or typewritten. All corrections (which have been initiated by the Bidder using erasures, strike out, line out, or "white-out") shall be typed or written in with ink adjacent thereto, and shall be initialed in ink by the person signing the bid proposal.
- C. Failure to initial all corrections made in the bidding documents may cause the Bid to be rejected as **non-responsive** and ineligible for further consideration.
- D. Blank spaces must be filled in, using figures. Bidder's failure to submit a price for any Bid item that requires the Bidder to submit a price shall render the Bid **non-responsive** and shall be cause for its rejection.
- E. Unit prices shall be entered for all unit price items. Unit prices shall not exceed two (2) decimal places. If the Unit prices entered exceed two (2) decimal places, the City will only use the first two digits after the decimal points without rounding up or down.
- F. All extensions of the unit prices bid will be subject to verification by the City. In the case of inconsistency or conflict between the product of the Quantity x Unit Price and the Extension, the product shall govern.
- G. In the case of inconsistency or conflict, between the sums of the Extensions with the estimated total Bid, the sum of the Extensions shall govern.
- H. Bids shall not contain any recapitulation of the Work. Conditional Bids will be rejected as being **non-responsive**. Alternative proposals will not be considered unless called for.
- I. Subcontractors' License Number must be filled in. Failure to provide the information specified may deem the bidder **non-responsive**.

BIDDING DOCUMENTS

LIST OF SUBCONTRACTORS

In accordance with the requirements provided in the "Subletting and Subcontracting Fair Practices Act", Division 2, Part 1, Chapter 4 of the Public Contract Code, the Bidder shall list below the name and address of each Subcontractor who will perform work, labor, render services or specially fabricates and installs a portion [type] of the work or improvement, in an amount in excess of 0.5% of the Contractor's total Bid. The Bidder shall also list below the portion of the work which will be done by each subcontractor under this Contract. The Contractor shall list only one Subcontractor for each portion of the Work. The **DOLLAR VALUE** of the total Bid to be performed shall be stated for all subcontractors listed. Failure to comply with this requirement shall result in the Bid being rejected as **non-responsive** and ineligible for award. The Bidder's attention is directed to the Special Provisions - General; Paragraph 2-3 Subcontracts, which stipulates the percent of the Work to be performed with the Bidders' own forces. The Bidder shall list all SLBE, ELBE, DBE, DVBE, MBE, WBE, OBE, SDB, WoSB, HUBZone, and SDVOSB Subcontractors that Bidders are seeking recognition towards achieving any mandatory, voluntary, or both subcontracting participation percentages.

Subcontractors' License Number must be filled in. Failure to provide the information specified may deem the bidder **non-responsive**.

NAME, ADDRESS AND TELEPHONE NUMBER OF SUBCONTRACTOR	CONSTRUCTOR OR DESIGNER	SUBCONTRACTOR LICENSE NUMBER	TYPE OF WORK	DOLLAR VALUE OF SUBCONTRACT (MUST BE FILLED OUT)	MBE, WBE, DBE, DVBE, OBE, ELBE, SLBE, SDB, WoSB, HUBZone, OR SDVOSB	WHERE CERTIFIED ①	CHECK IF JOINT VENTURE PARTNERSHIP
Name: <u>Merkel & Associates, Inc.</u> Address: <u>5434 Ruffin Road</u> City: <u>San Diego</u> State: <u>CA</u> Zip: <u>92123</u> Phone: <u>858-560-5465</u> Email: <u>associates@merkelinc.com</u>	Designer	N/A	Biologist Monitoring	\$10,400.00	N/A	N/A	
Name: _____ Address: _____ City: _____ State: _____ Zip: _____ Phone: _____ Email: _____							

① As appropriate, Bidder shall identify Subcontractor as one of the following and shall include a valid proof of certification (except for OBE, SLBE and ELBE):

Certified Minority Business Enterprise	MBE	Certified Woman Business Enterprise	WBE
Certified Disadvantaged Business Enterprise	DBE	Certified Disabled Veteran Business Enterprise	DVBE
Other Business Enterprise	OBE	Certified Emerging Local Business Enterprise	ELBE
Certified Small Local Business Enterprise	SLBE	Small Disadvantaged Business	SDB
Woman-Owned Small Business	WoSB	HUBZone Business	HUBZone
Service-Disabled Veteran Owned Small Business	SDVOSB		

② As appropriate, Bidder shall indicate if Subcontractor is certified by:

City of San Diego	CITY	State of California Department of Transportation	CALTRANS
California Public Utilities Commission	CPUC	San Diego Regional Minority Supplier Diversity Council	SRMSDC
State of California's Department of General Services	CADoGS	City of Los Angeles	LA
State of California	CA	U.S. Small Business Administration	SBA

The Bidder will not receive any subcontracting participation percentages if the Bidder fails to submit the required proof of certification.

BIDDING DOCUMENTS

NAMED EQUIPMENT/MATERIAL SUPPLIER LIST

The Bidder seeking the recognition of equipment, materials, or supplies obtained from Suppliers towards achieving any mandatory, voluntary, or both subcontracting participation percentages shall list the Supplier(s) on the Named Equipment/Material Supplier List. The Named Equipment/Material Supplier List, at a minimum, shall have the name, locations (City) and the **DOLLAR VALUE** of the Suppliers. The Bidder will be credited up to 60% of the amount to be paid to the Suppliers for such materials and supplies unless vendor manufactures or substantially alters materials and supplies in which case 100% will be credited. The Bidder is to indicate (Yes/No) whether listed firm is a supplier or manufacturer. In calculating the subcontractor participation percentages, vendors/suppliers will receive 60% credit of the listed **DOLLAR VALUE**, whereas manufacturers will receive 100% credit. If no indication provided, listed firm will be credited at 60% of the listed dollar value for purposes of calculating the Subcontractor Participation Percentage. Suppliers will receive 60% credit of the listed **DOLLAR VALUE**, whereas manufacturers will receive 100% credit. If no indication provided, listed firm will be credited at 60% of the listed **DOLLAR VALUE** for purposes of calculating the subcontractor participation percentages.

NAME, ADDRESS AND TELEPHONE NUMBER OF VENDOR/SUPPLIER	MATERIALS OR SUPPLIES	DOLLAR VALUE OF MATERIAL OR SUPPLIES (MUST BE FILLED OUT)	SUPPLIER (Yes/No)	MANUFACTURER (Yes/No)	MBE, WBE, DBE, DVBE, OBE, ELBE, SLBE, SDB, WoSB, HUBZone, OR SDVOSB	WHERE CERTIFIED
Name: _____ Address: _____ City: _____ State: _____ Zip: _____ Phone: _____ Email: _____						
Name: _____ Address: _____ City: _____ State: _____ Zip: _____ Phone: _____ Email: _____						

① As appropriate, Bidder shall identify Vendor/Supplier as one of the following and shall include a valid proof of certification (except for OBE,SLBE and ELBE):

Certified Minority Business Enterprise	MBE	Certified Woman Business Enterprise	WBE
Certified Disadvantaged Business Enterprise	DBE	Certified Disabled Veteran Business Enterprise	DVBE
Other Business Enterprise	OBE	Certified Emerging Local Business Enterprise	ELBE
Certified Small Local Business Enterprise	SLBE	Small Disadvantaged Business	SDB
Woman-Owned Small Business	WoSB	HUBZone Business	HUBZone
Service-Disabled Veteran Owned Small Business	SDVOSB		

② As appropriate, Bidder shall indicate if Vendor/Supplier is certified by:

City of San Diego	CITY	State of California Department of Transportation	CALTRANS
California Public Utilities Commission	CPUC	San Diego Regional Minority Supplier Diversity Council	SRMSDC
State of California's Department of General Services	CADoGS	City of Los Angeles	LA
State of California	CA	U.S. Small Business Administration	SBA

The Bidder will not receive any subcontracting participation percentages if the Bidder fails to submit the required proof of certification.



BID BOND

CONTRACTOR:

(Name, legal status and address)
BLUE PACIFIC ENGINEERING & CONSTRUCTION
7330 OPPORTUNITY ROAD, SUITE J
SAN DIEGO, CA 92111

SURETY:

North American Specialty Insurance Company
475 N. Martingale Road, Suite 850
Schaumburg, IL 60173

OWNER:

(Name, legal status and address)
CITY OF SAN DIEGO
202 C STREET
SAN DIEGO 92101

This document has important legal consequences. Consultation with an attorney is encouraged with respect to its completion or modification.

BOND AMOUNT: TEN PERCENT OF GREATER AMOUNT BID -----

Any singular reference to Contractor, Surety, Owner or other party shall be considered plural where applicable.

PROJECT:

(Name, location or address, and Project number, if any)
TRAIL FOR ALL PEOPLE L-16-1240-DBB-1

The Contractor and Surety are bound to the Owner in the amount set forth above, for the payment of which the Contractor and Surety bind themselves, their heirs, executors, administrators, successors and assigns, jointly and severally, as provided herein. The conditions of this Bond are such that if the Owner accepts the bid of the Contractor within the time specified in the bid documents, or within such time period as may be agreed to by the Owner and Contractor, and the Contractor either (1) enters into a contract with the Owner in accordance with the terms of such bid, and gives such bond or bonds as may be specified in the bidding or Contract Documents, with a surety admitted in the jurisdiction of the Project and otherwise acceptable to the Owner, for the faithful performance of such Contract and for the prompt payment of labor and material furnished in the prosecution thereof; or (2) pays to the Owner the difference, not to exceed the amount of this Bond, between the amount specified in said bid and such larger amount for which the Owner may in good faith contract with another party to perform the work covered by said bid, then this obligation shall be null and void, otherwise to remain in full force and effect. The Surety hereby waives any notice of an agreement between the Owner and Contractor to extend the time in which the Owner may accept the bid. Waiver of notice by the Surety shall not apply to any extension exceeding sixty (60) days in the aggregate beyond the time for acceptance of bids specified in the bid documents, and the Owner and Contractor shall obtain the Surety's consent for an extension beyond sixty (60) days.

If this Bond is issued in connection with a subcontractor's bid to a Contractor, the term Contractor in this Bond shall be deemed to be Subcontractor and the term Owner shall be deemed to be Contractor.

When this Bond has been furnished to comply with a statutory or other legal requirement in the location of the Project, any provision in this Bond conflicting with said statutory or legal requirement shall be deemed deleted herefrom and provisions conforming to such statutory or other legal requirement shall be deemed incorporated herein. When so furnished, the intent is that this Bond shall be construed as a statutory bond and not as a common law bond.

Signed and sealed this 1ST day of

SEPTEMBER, 2015

(Witness)

BLUE PACIFIC ENGINEERING & CONSTRUCTION

(Principal)

(Seal)

BY:

(Title)

North American Specialty Insurance Company

(Surety)

(Seal)

BY:

(Title) JOHN B. MALONEY ATTORNEY-IN-FACT

CALIFORNIA ALL-PURPOSE ACKNOWLEDGMENT

CIVIL CODE § 1189

A notary public or other officer completing this certificate verifies only the identity of the individual who signed the document to which this certificate is attached, and not the truthfulness, accuracy, or validity of that document.

State of California)
County of SAN DIEGO)
On 9/1/2015 before me, MICHELLE M. BASUIL, NOTARY PUBLIC,
Date Here Insert Name and Title of the Officer
personally appeared JOHN G. MALONEY
Name(s) of Signer(s)

who proved to me on the basis of satisfactory evidence to be the person(s) whose name(s) is/are subscribed to the within instrument and acknowledged to me that he/she/they executed the same in his/her/their authorized capacity(ies), and that by his/her/their signature(s) on the instrument the person(s), or the entity upon behalf of which the person(s) acted, executed the instrument.

I certify under PENALTY OF PERJURY under the laws of the State of California that the foregoing paragraph is true and correct.

WITNESS my hand and official seal.

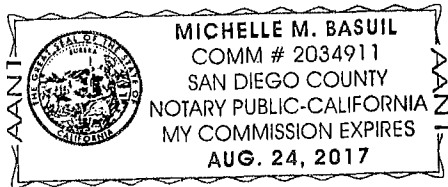

Signature Michelle M. Basuil
Signature of Notary Public

Place Notary Seal Above

OPTIONAL

Though this section is optional, completing this information can deter alteration of the document or fraudulent reattachment of this form to an unintended document.

Description of Attached Document

Title or Type of Document: _____ Document Date: _____
Number of Pages: _____ Signer(s) Other Than Named Above: _____

Capacity(ies) Claimed by Signer(s)

Signer's Name: JOHN G. MALONEY
 Corporate Officer — Title(s): _____
 Partner — Limited General
 Individual Attorney in Fact
 Trustee Guardian or Conservator
 Other: _____

Signer's Name: _____
 Corporate Officer — Title(s): _____
 Partner — Limited General
 Individual Attorney in Fact
 Trustee Guardian or Conservator
 Other: _____

Signer Is Representing: _____

Signer Is Representing: _____

City of San Diego

CITY CONTACT: Clementina Giordano, Contract Specialist, Email: CGiordano@sandiego.gov.
Phone No. (619) 533-3481, Fax No. (619) 533-3633

ADDENDUM "A"

FOR

TRAIL FOR ALL PEOPLE



BID NO.:	<u>L-16-1240-DBB-1</u>
SAP NO. (WBS/IO/CC):	<u>S-13001</u>
CLIENT DEPARTMENT:	<u>1714</u>
COUNCIL DISTRICT:	<u>5</u>
PROJECT TYPE:	<u>GD</u>

BID DUE DATE:

**1:30 PM
SEPTEMBER 2, 2015
CITY OF SAN DIEGO
PUBLIC WORKS CONTRACTS
1010 SECOND AVENUE, 14th FLOOR, MS 614C
SAN DIEGO, CA 92101**

ENGINEER OF WORK

The engineering Specifications and Special Provisions contained herein have been prepared by or under the direction of the following Registered Engineer:

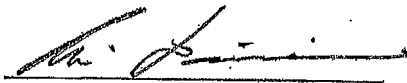

For City Engineer

8/20/15
Date

Seal:

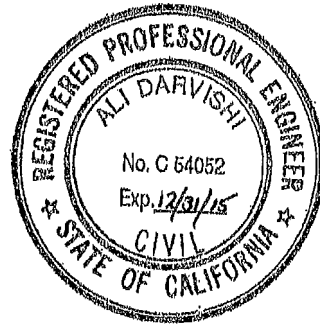

A. CHANGES TO CONTRACT DOCUMENTS

The following changes to the Contract Documents are hereby made effective as though originally issued with the bid package. Bidders are reminded that all previous requirements to this solicitation remain in full force and effect.

B. VOLUME 1

1. To Notice Inviting Bids, Item 31, Required Document Schedule, Page 14, to Required Document Schedule table, **ADD** the following:

16.	WITHIN 3 WORKING DAYS OF THE BID OPENING DATE	THREE APPARENT LOW BIDDERS	Biologist's Experience and Past Project Documentation. See section 700.
-----	---	----------------------------	---

2. To Attachment E, Supplementary Special Provisions, Section 700, Extended Revegetation, Maintenance, and Monitoring, Subsection 700-1.7.2, Project Biologist, Page 45, **ADD** the following:

Within 3 Working Days of the Bid opening date, the three apparent low bidders are to submit copies of the following:

- The Biologist's qualifications as noted in 700-1.1
- The Biologist's Experience; past project documentation of at least 1 successfully completed project of similar size and complexity in Southern California

C. PLANS

1. To Drawings numbered 37860-1-D, 37860-2-D, 37860-3-D, 37860-6-D, 37860-7-D, **DELETE** in their entirety and **REPLACE** with pages 4 through 8 of this Addendum.

James Nagelvoort, Director
Public Works Department

Dated: *August 20, 2015*
San Diego, California

JN/RWB/egz

CONSTRUCTION NOTES

1. ALL CONSTRUCTION SHALL BE IN ACCORDANCE WITH THE CITY OF SAN DIEGO... 2. THE CONTRACTOR SHALL BE RESPONSIBLE FOR OBTAINING ALL NECESSARY PERMITS... 3. ALL CONSTRUCTION SHALL BE IN ACCORDANCE WITH THE CITY OF SAN DIEGO...

REVEGETATION NOTES

1. ALL REVEGETATION SHALL BE IN ACCORDANCE WITH THE CITY OF SAN DIEGO... 2. THE CONTRACTOR SHALL BE RESPONSIBLE FOR OBTAINING ALL NECESSARY PERMITS... 3. ALL REVEGETATION SHALL BE IN ACCORDANCE WITH THE CITY OF SAN DIEGO...

EROSION AND SEDIMENT CONTROL NOTES

1. ALL EROSION AND SEDIMENT CONTROL MEASURES SHALL BE IN ACCORDANCE WITH THE CITY OF SAN DIEGO... 2. THE CONTRACTOR SHALL BE RESPONSIBLE FOR OBTAINING ALL NECESSARY PERMITS... 3. ALL EROSION AND SEDIMENT CONTROL MEASURES SHALL BE IN ACCORDANCE WITH THE CITY OF SAN DIEGO...

STORM WATER PROTECTION

1. ALL STORM WATER PROTECTION MEASURES SHALL BE IN ACCORDANCE WITH THE CITY OF SAN DIEGO... 2. THE CONTRACTOR SHALL BE RESPONSIBLE FOR OBTAINING ALL NECESSARY PERMITS... 3. ALL STORM WATER PROTECTION MEASURES SHALL BE IN ACCORDANCE WITH THE CITY OF SAN DIEGO...

SEED MIX

Table with 3 columns: Solonchlo Name, Common Name, and Minimum PLS/LX/PLX. Includes entries like Agrostis, Bromus, and Poa.

CONTRACTOR'S RESPONSIBILITIES

1. THE CONTRACTOR SHALL BE RESPONSIBLE FOR OBTAINING ALL NECESSARY PERMITS... 2. THE CONTRACTOR SHALL BE RESPONSIBLE FOR OBTAINING ALL NECESSARY PERMITS... 3. THE CONTRACTOR SHALL BE RESPONSIBLE FOR OBTAINING ALL NECESSARY PERMITS...

MINIMUM POST-CONSTRUCTION MAINTENANCE PLAN

1. THE CONTRACTOR SHALL BE RESPONSIBLE FOR OBTAINING ALL NECESSARY PERMITS... 2. THE CONTRACTOR SHALL BE RESPONSIBLE FOR OBTAINING ALL NECESSARY PERMITS... 3. THE CONTRACTOR SHALL BE RESPONSIBLE FOR OBTAINING ALL NECESSARY PERMITS...

ENVIRONMENTAL/MITIGATION REQUIREMENTS

1. ALL ENVIRONMENTAL/MITIGATION REQUIREMENTS SHALL BE IN ACCORDANCE WITH THE CITY OF SAN DIEGO... 2. THE CONTRACTOR SHALL BE RESPONSIBLE FOR OBTAINING ALL NECESSARY PERMITS... 3. ALL ENVIRONMENTAL/MITIGATION REQUIREMENTS SHALL BE IN ACCORDANCE WITH THE CITY OF SAN DIEGO...

CONSTRUCTION OF TRAIL FOR ALL PEOPLE

1. ALL CONSTRUCTION SHALL BE IN ACCORDANCE WITH THE CITY OF SAN DIEGO... 2. THE CONTRACTOR SHALL BE RESPONSIBLE FOR OBTAINING ALL NECESSARY PERMITS... 3. ALL CONSTRUCTION SHALL BE IN ACCORDANCE WITH THE CITY OF SAN DIEGO...

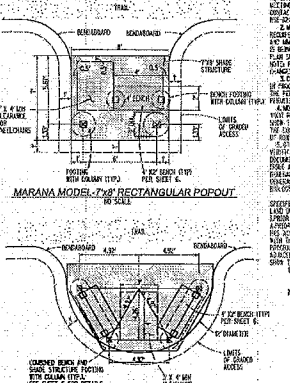

DECLARATION OF RESPONSIBLE CHARGE

I, the undersigned, declare that I am the responsible charge for the construction of the project... I, the undersigned, declare that I am the responsible charge for the construction of the project...

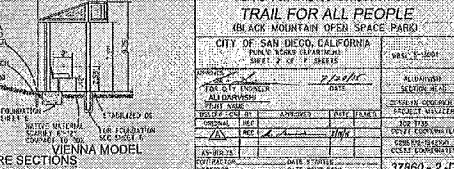

ABBREVIATIONS table listing various codes and their meanings, such as 'ASPC' for Asphalt Concrete and 'RICK' for Rick's Construction.

Prepared by: Rick's Construction, Inc. 10/10/2008

ADDENDUM A AND NOTE TO REVISIONS NOTES

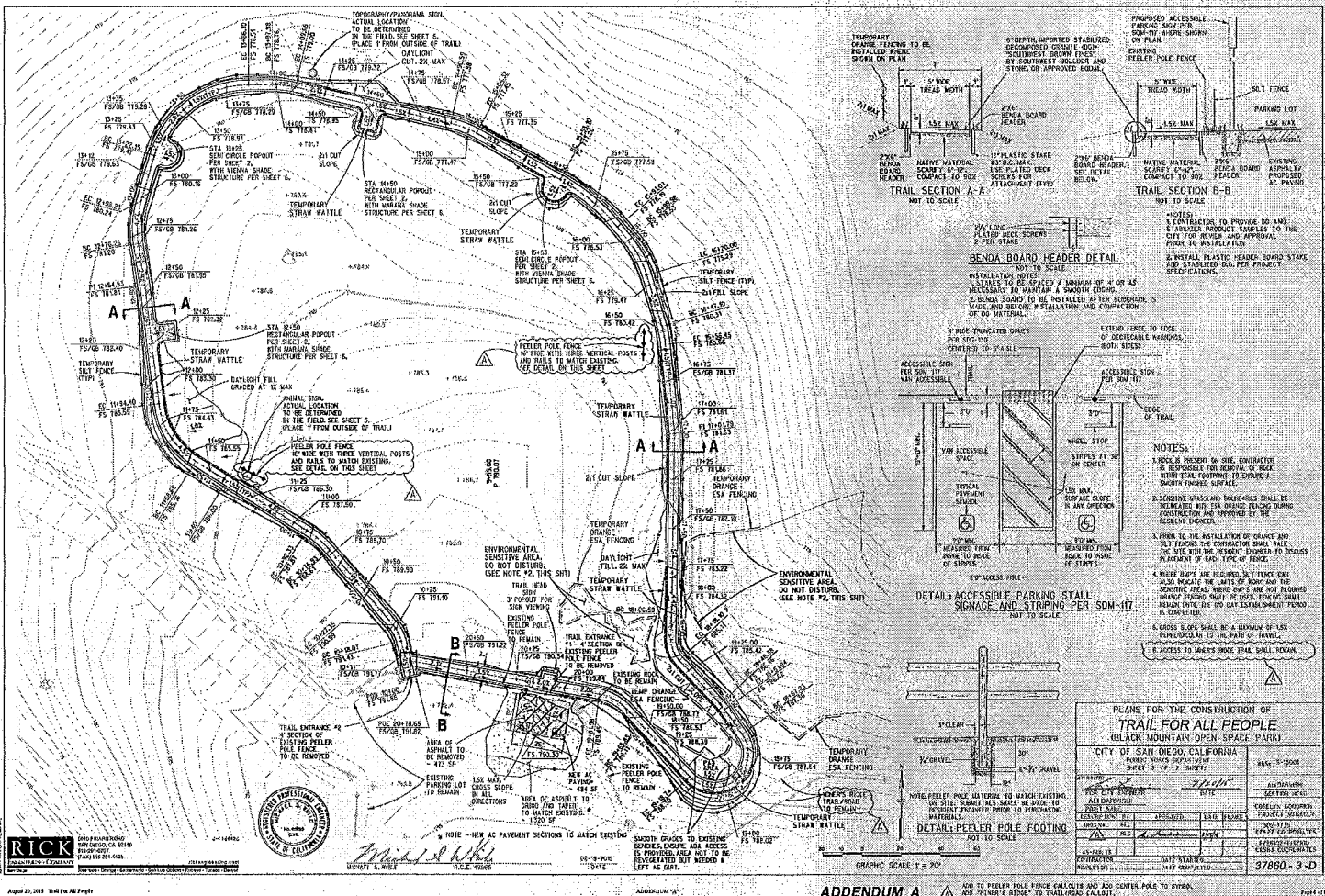

RICK
 4400 LA JOLLA VILLAGE ROAD
 SAN DIEGO, CA 92138
 (619) 594-1100
 (619) 594-1101
 (619) 594-1102



Miss W.K.
 MISS W.K. WILSON
 06-1-K-00
 1946

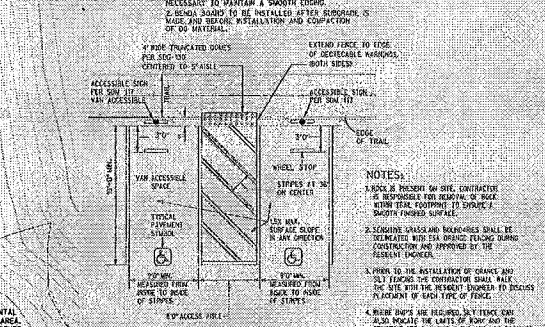
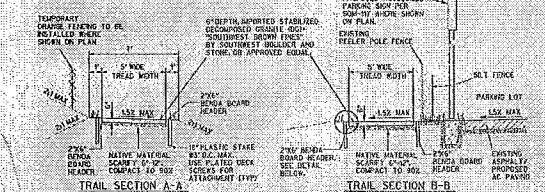

PLANS FOR THE CONSTRUCTION OF
TRAIL FOR ALL PEOPLE
 (BLACK MOUNTAIN OPEN SPACE PARK)

CITY OF SAN DIEGO, CALIFORNIA
 PUBLIC WORKS DEPARTMENT
 SHEET 3 OF 3 SHEETS

DATE	11/16/06	NO.	37880-3-D
DESIGNED BY	W.K. WILSON	CHECKED BY	W.K. WILSON
DRAWN BY	W.K. WILSON	DATE	11/16/06
SCALE	AS SHOWN	PROJECT NO.	37880
CONTRACT NO.	114P	DATE STARTED	11/16/06
LOCATION	BLACK MOUNTAIN	DATE COMPLETED	11/16/06

ADDENDUM A
 ADD TO PEELER POLE FENCE CALCULUS AND ADD CENTER POLE TO SYMBOL.
 ADD 'PEELER POLE' TO OVERLAP AREA.
 ADD NOTE # TO 'NOTES'.

"MARANA" SHADE STRUCTURE - FOUNDATION PLAN

SCALE: 3/4" = 1'-0"

NOTES:

- PROVIDE "MARANA" (12" x 8" x 8") SHADE STRUCTURE AS MANUFACTURED BY "TOS INC.", OR APPROVED EQUAL.
- REINFORCING SHALL NOT FABRICATE ANY MATERIAL PRIOR TO CONSTRUCTION OF THE STRUCTURE UNLESS WITH (A) PERI DRIVE STRUCTURE MANUFACTURER'S SHOP DRAWINGS.

"VIENNA" SHADE STRUCTURE - FOUNDATION PLAN

SCALE: 3/4" = 1'-0"

NOTES:

- PROVIDE "VIENNA" (12" x 8" x 8") SHADE STRUCTURE AS MANUFACTURED BY "TOS INC.", OR APPROVED EQUAL.
- CONSTRUCTED SHALL USE PRECASTED AND MATERIAL SHALL BE TO THE DISCRETION OF THE ENGINEER MARKED WITH (A) WITH PERI DRIVE STRUCTURE MANUFACTURER'S SHOP DRAWINGS.

"MARANA" SHADE STRUCTURE SECTION

SCALE: 1" = 1'-0"

"VIENNA" SHADE STRUCTURE SECTION

SCALE: 1" = 1'-0"

SHADE STRUCTURE SECTION

SCALE: 1-1/2" = 1'-0"

GRADE BEAM SECTION

SCALE: 1-1/2" = 1'-0"

BENCH FOOTING PLAN VIEW

N.T.S.

BENCH FOOTING PROFILE

N.T.S.

BENCH - TYPICAL ELEVATIONS

SCALE: 1" = 1'-0"

DETAIL

SCALE: 1" = 1'-0"

GENERAL INSPECTION NOTES:

- SPECIAL INSPECTION FOR ENHANCED CONSTRUCTION SHALL BE WITH THE CONTRACTOR IN ACCORDANCE WITH THE REQUIREMENTS OF THE TABLE BELOW

ITEM	INSPECTION REQUIREMENT	REQ. DATE	REQ. TIME	REMARKS
GRADE BEAM POSITION	AS SHOWN	1705.2	1705.2	
CONCRETE CONSTRUCTION	AS SHOWN	1705.3	1705.3	
ROOFING CONSTRUCTION	AS SHOWN	1705.4	1705.4	

- WORK TO THE APPROVAL OF THE ENGINEER OR ARCHITECT OR ENGINEER OF RECORD BY USING THE ENHANCED CONSTRUCTION DRAWINGS FOR CONSTRUCTION AND INSPECTION OF THE WORK. THE ENGINEER, ARCHITECT OR ENGINEER OF RECORD SHALL BE RESPONSIBLE FOR THE VERIFICATION OF THE CONSTRUCTION AND INSPECTION OF THE WORK. THE ENGINEER, ARCHITECT OR ENGINEER OF RECORD SHALL BE RESPONSIBLE FOR THE VERIFICATION OF THE CONSTRUCTION AND INSPECTION OF THE WORK. THE ENGINEER, ARCHITECT OR ENGINEER OF RECORD SHALL BE RESPONSIBLE FOR THE VERIFICATION OF THE CONSTRUCTION AND INSPECTION OF THE WORK.
- THE SPECIAL INSPECTION MUST BE PERFORMED BY THE CITY OF SAN DIEGO INSPECTION DEPARTMENT OR THE CONTRACTOR'S INSPECTION DEPARTMENT. THE SPECIAL INSPECTION MUST BE PERFORMED BY THE CITY OF SAN DIEGO INSPECTION DEPARTMENT OR THE CONTRACTOR'S INSPECTION DEPARTMENT.

DATE SIGNED: 7/26/2016

PLANS FOR THE CONSTRUCTION OF
TRAIL FOR ALL PEOPLE
SHADE STRUCTURE, PLANT SIGN FOOTING AND BENCH FOOTINGS

CITY OF SAN DIEGO, CALIFORNIA
PUBLIC WORKS DEPARTMENT
SHEET: A OF 7 - 0000

APPROVED:	DATE:	ALL REVISIONS:
DESIGNED BY:	DATE:	SECTION: 3040
DRAWN BY:	DATE:	PROJECT NUMBER:
CHECKED BY:	DATE:	ISSUE:
REVISIONS:	DATE:	ISSUE:
PROJECT:	DATE:	ISSUE:
DATE:	DATE:	ISSUE:

37860 - 6-D

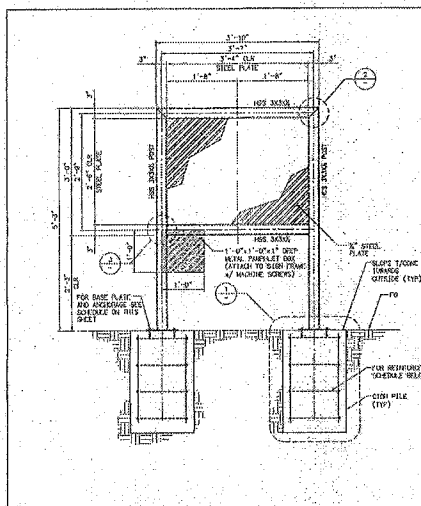

TRAIL HEAD SIGN - TYPICAL ELEVATION
SCALE: 1" = 1'-0"

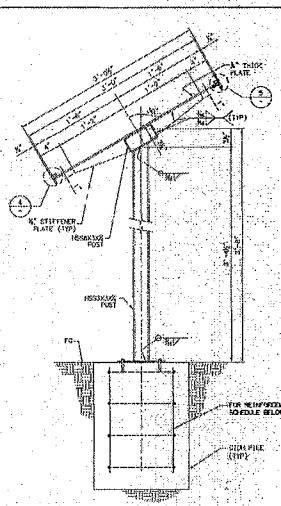
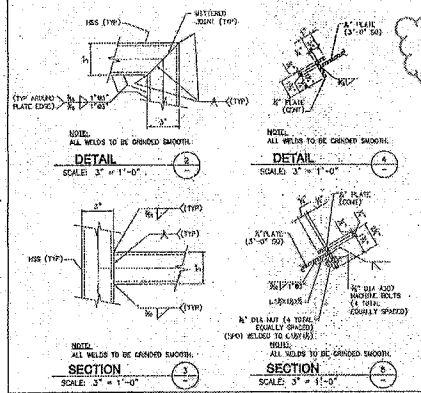

INTERPRETIVE SIGN - TYPICAL ELEVATION
SCALE: 1" = 1'-0"

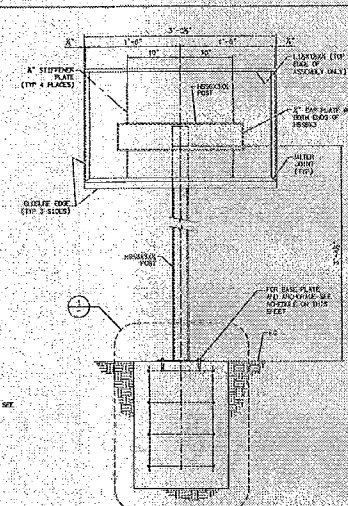
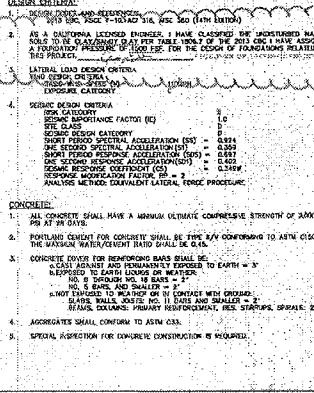

TRAIL HEAD SIGN - TYPICAL ELEVATION
SCALE: 1" = 1'-0"

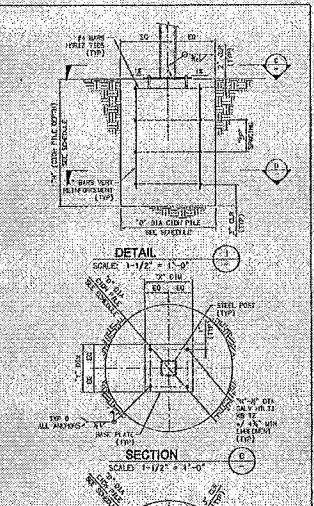

TRAIL HEAD SIGN - TYPICAL ELEVATION
SCALE: 1" = 1'-0"

GENERAL NOTES:

- DESIGN CRITERIA:**
1. AS A CALIFORNIA LICENSED ENGINEER, I HAVE CLASSIFIED THE UNDERSTAND MATING ROAD TO BE EQUIVALENT TO THE FREEWAY OF THE 1973 I.H.A. I HAVE ASSIGNED A WINDLOAD PRESSURE OF 1500 LBS/FT² FOR THE DESIGN OF FOUNDATIONS RELATED TO THIS PROJECT.
- LATERAL LOAD DESIGN CRITERIA:**
2. EXPOSURE CATEGORY: B
3. WIND SPEED: 110 MPH (15% EXCEED)
- SEISMIC DESIGN CRITERIA:**
4. SEISMIC DESIGN CATEGORY: B
5. SHORT PERIOD SPECTRAL ACCELERATION (S_{0.1}) = 0.204
6. ONE SECOND SPECTRAL ACCELERATION (S₁) = 0.202
7. SHORT PERIOD RESPONSE ACCELERATION (R_{0.1}) = 0.817
8. ONE SECOND RESPONSE ACCELERATION (R₁) = 0.422
9. SEISMIC RESPONSE COEFFICIENT (C_s) = 0.250
10. RESPONSE MODIFICATION FACTOR (R) = 2
11. ANALYSIS METHOD: EQUIVALENT LATERAL FORCE PROCEDURE.
- CONCRETE:**
1. ALL CONCRETE SHALL HAVE A MINIMUM COMPRESSIVE STRENGTH OF 4000 PSI AT 28 DAYS.
2. PORTLAND CEMENT FOR CONCRETE SHALL BE TYPE I/II CONFORMING TO ASTM C150. THE MAXIMUM WATER-CEMENT RATIO SHALL BE 0.45.
3. CONCRETE COVER FOR REINFORCING BARS SHALL BE:
- CAST AGAINST AND PERMANENTLY EXPOSED TO WEATHER = 3" (EXPOSED TO WEATHER AND IN CONTACT WITH GROUND)
 - CAST AGAINST AND PERMANENTLY EXPOSED TO WEATHER = 2" (EXPOSED TO WEATHER AND IN CONTACT WITH GROUND)
 - CAST AGAINST AND PERMANENTLY EXPOSED TO WEATHER = 1.5" (EXPOSED TO WEATHER AND IN CONTACT WITH GROUND)
4. REINFORCING BARS SHALL BE TYPE 60 EPOXY COATED BARS CONFORMING TO ASTM A641.
5. SPECIAL INSPECTION FOR CONCRETE CONSTRUCTION IS REQUIRED.

REINFORCING STEEL:

1. REINFORCEMENT FOR CONCRETE AND MASONRY SHALL BE PROVIDED BARS CONFORMING TO ASTM A618 (FOR WELDED REINFORCEMENT) OR ASTM A615 (FOR UNWELDED REINFORCEMENT).
- STRUCTURAL STEEL:**
1. ALL STRUCTURAL AND MISCELLANEOUS STEEL SHALL BE FABRICATED IN ACCORDANCE WITH THE AISC SPECIFICATION FOR THE DESIGN, FABRICATION AND ERECTION OF STRUCTURAL STEEL FOR BUILDINGS.
2. WALL OF STEEL MEMBERS, HSS (EXCEPT HSS 12X12) SHALL CONFORM TO ASTM A500 GRADE B.
3. PLATE BARS AND ITEMS OF MISCELLANEOUS METALWORK SHALL CONFORM TO ASTM A36.
4. ALL WELDS SHALL CONFORM TO THE AISC WELDED CONNECTIONS MANUAL. ALL WELDED JOINTS SHALL BE FULL PENETRATION JOINTS. ALL WELDED JOINTS SHALL BE FULL PENETRATION JOINTS. ALL WELDED JOINTS SHALL BE FULL PENETRATION JOINTS.
5. SPECIAL INSPECTION FOR WELDING IS NOT REQUIRED.
6. ALL STEEL EXPOSED TO WEATHER SHALL BE SHOP POWER COATED. PAINT COLOR SHALL BE "RAL 7001" AND APPROVED BY ARCHITECT. CONTRACTOR SHALL VERIFY PAINT SHALL BE THE DESIGN ENGINEER FOR REVIEW AND APPROVAL.

TRAIL HEAD SIGN AND INTERPRETIVE SIGN CDTI FILE TO BE DRAWN SPEEDY	1'-0"	2'-0"	3'-0"	4'-0"	5'-0"	6'-0"	7'-0"	8'-0"	9'-0"	10'-0"
TRAIL HEAD SIGN	1'-0"	2'-0"	3'-0"	4'-0"	5'-0"	6'-0"	7'-0"	8'-0"	9'-0"	10'-0"
INTERPRETIVE SIGN	1'-0"	2'-0"	3'-0"	4'-0"	5'-0"	6'-0"	7'-0"	8'-0"	9'-0"	10'-0"

PLANS FOR THE CONSTRUCTION OF
TRAIL FOR ALL PEOPLE
TRAIL HEAD SIGN AND INTERPRETIVE SIGN DETAILS

CITY OF SAN DIEGO, CALIFORNIA
SAN DIEGO WATER DEPARTMENT
SHEET 7 OF 7 (SHEET)

DATE: 11/11/03

DESIGNED BY: [Signature]

CHECKED BY: [Signature]

APPROVED BY: [Signature]

DATE: 11/11/03

PROJECT NUMBER: 37880-7-D