

DUPLICATE

K166614

**REIMBURSEMENT AGREEMENT WITH PARDEE HOMES
FOR PHASE II OF PROJECT NO. T-4.2 CARMEL VALLEY
ROAD (4/6 LANES SOUTH OF DEL MAR HEIGHTS
ROAD), IN THE PACIFIC HIGHLANDS RANCH
COMMUNITY-REIMBURSEMENT AGREEMENT NO.
1332832**

THIS REIMBURSEMENT AGREEMENT No. 1332832 (Agreement) is made and entered into between the City of San Diego, a municipal corporation (City) and Pardee Homes, a California Corporation] (Developer), (collectively the Parties), for reimbursement for purchase, design, and construction of Phase II of Project No. T-4.2, Carmel Valley Road, (4/6 lanes south of Del Mar Heights Road) in the Pacific Highlands Ranch Subarea Plan in accordance with the Pacific Highlands Ranch Public Facilities Financing Plan.

RECITALS

1. Developer owns real property in the Pacific Highlands Ranch Subarea Plan (Property). Developer certifies that it is developing the Property subject to the requirements and conditions of the City Council of the City of San Diego (City Council).
2. On September 24, 2002, by San Diego Resolution R-297087, City Council granted Vesting Tentative Map No. 7248 for Units #5-11 (VTM) subject to certain conditions determined to be necessary for Developer's development.
3. On April 10, 2012, by San Diego Resolution R-307364, the City Council adopted the Pacific Highlands Ranch Public Facilities Financing Plan and Facilities Benefit Assessment (FBA) for Fiscal Year 2013 (Financing Plan). The Financing Plan identifies Project No. T-4.2, Carmel Valley Road (4/6 lanes south of Del Mar Heights Road-Phase II) as shown in **Exhibit A**. This Agreement relates to a portion of Project No. T-4.2. Specifically, this Agreement relates to Phase II of Project No. T-4.2 involving the addition of lanes 5 and 6 within the median of Carmel Valley Road (4/6 lanes south of Del Mar Heights Road) as depicted in **Exhibit B** and described in **Exhibit C**, which is referred to throughout this Agreement as the "Project."
4. The Financing Plan estimate of \$3,674,761 minus the City's Administrative Costs (as defined in Section 12.1.5) and minus City's equipment expenditures, constitute the total and maximum City funds potentially available for reimbursement to Developer for Project No. T-4.2, Phase II. Of that amount, a maximum of \$1,801,000 is available for reimbursement for the Project that is the subject of this Agreement (Maximum Funds); any amount in excess of the Maximum Funds may not be reimbursed through this Agreement and shall constitute a Non-Reimbursable Cost. Developer is not automatically entitled to the Maximum Funds or any other reimbursement. Developer must satisfy all terms of this Agreement to become eligible for any portion of the Maximum Funds if and as they are collected and become available for reimbursement.
5. Developer's Estimated Cost (as defined in Section 3.3) for the Project is \$ 1,801,000 including interest (as discussed in Section 12.1.6).

NOW, THEREFORE, in consideration of the recitals and mutual obligations of the Parties, and for other good and valuable consideration, City and Developer agree as follows:

DOCUMENT NO. 00-20519
FILED JUL 14 2015
OFFICE OF THE CITY CLERK
SAN DIEGO, CALIFORNIA

ARTICLE I. SUBJECT OF THE AGREEMENT

- 1.1 **Design and Construction of Project.** Developer agrees to design and construct the Project fully complete and operational and suited to the purpose for which it was designed and in accordance with this Agreement, the Plans and Specifications, and the Financing Plan, and within the timeframe established in the Project Schedule attached as **Exhibit D**, and for the Estimated Costs attached as **Exhibit E**.
- 1.2 **Substantial and Final Completion.** City's acceptance of the Project shall occur upon Developer's receipt of a letter of Substantial Completion from City (as defined in Section 15.1). Final Completion of the Project shall not occur until after approval of the as-built plans, a signed as final approval for grading or public right-of-way permit, acceptable capitalization form, and any required certificate of occupancy and/or property transfers (as defined in Section 16.1).
- 1.3 **Reimbursement.** City agrees to reimburse Developer for the Project subject to the terms and conditions of this Agreement.

ARTICLE II. PROJECT SCHEDULE

- 2.1 **Project Schedule.** Developer shall perform and complete the work under this Agreement according to the Project Schedule attached as **Exhibit D**, the Project Schedule Obligations and Components attached as **Exhibit F**, the Meeting Requirements in **Exhibit G**; and Preconstruction, Progress, and Special Meeting Agendas in **Exhibit H**.
- 2.2 **Project Completion.** Developer agrees that all work on the Project under this Agreement will be complete and ready for operational use according to the Project Schedule, and the Project Schedule Obligations and Components.
- 2.3 **Changes in Project Schedule.**
 - 2.3.1 Changes in the Project Schedule that increase the Estimated Cost must be approved by City in writing in accordance with Section 3.3.3.
 - 2.3.2 Changes in the Project Schedule that do not increase the Estimated Cost may be approved by the engineer designated by the City's Public Works Department (Responsible Department), which shall be responsible for review and approval of the progress of, and changes to, the Project (Resident Engineer); provided, however, that the Project is still completed in accordance with the Financing Plan (including any associated phasing plans) and all conditions of approval including, but not limited to the VTM and the VTM Conditions.
- 2.4 **Notification of Delay.** If Developer anticipates or has reason to believe that performance of work under this Agreement will be delayed, Developer shall immediately notify the representative designated by the City's Public Works Department to manage the Project on behalf of City (Project Manager). Unless City grants Developer additional time to ascertain supporting data, a written notice of the delay must be delivered to City within thirty (30) calendar days of the initial notification and shall include an explanation of the cause of the delay, a reasonable estimate of the length of the delay, any anticipated increased costs due to the delay, all supporting data, and a written statement that the time adjustment requested is the entire time adjustment Developer needs as a result of the

cause of the delay. If Developer anticipates or has reason to believe the delay will increase the Estimated Cost, Developer shall also give notice to City in accordance with Section 3.4.

2.5 Delay. If delay in the performance of work required under this Agreement is caused by unforeseen events beyond the control of the Parties, such delay may entitle Developer to a reasonable extension of time. Any such extension of time must be approved in writing by City, and will not be unreasonably withheld. A delay in the performance of work or any activity by City or Developer that affects a deadline to perform imposed on the other party by this Agreement will entitle the other party to the number of days City or Developer failed to complete performance of the work. The following conditions may justify such a delay depending on their actual impact on the Project: war; changes in law or government regulation; later commonly accepted or adopted higher standards and specifications of construction; labor disputes or strikes; fires; floods; adverse weather or other similar condition of the elements necessitating temporary cessation of Developer's work; concealed conditions encountered in the completion of the Project; inability to reasonably obtain materials, equipment, labor, or additional required services; or other specific reasons mutually agreed to in writing by City and Developer. Any delay claimed to be caused by Developer's inability to obtain materials, equipment, labor, or additional required services shall not entitle Developer to an extension of time unless Developer furnishes to City, in accordance with the notification requirements in Section 2.4, documentary proof satisfactory to City of Developer's inability to reasonably obtain materials, equipment, labor, or additional required services. Notwithstanding the above, Developer shall not be entitled to any extension of time, additional costs, or expenses for any delay caused by the acts or omissions of Developer, its consultants, contractors, subcontractors, employees, or other agents (collectively, Developer's agents). A change in the Project Schedule does not automatically entitle Developer to an increase in Reimbursable Costs (as defined in Section 3.2). If City determines that the delay materially affects the Project, City may exercise its rights under Section 2.7 of this Agreement.

2.6 Costs of Delay. City and Developer acknowledge construction delays may increase the cost of the Project. Unless Developer informs City pursuant to Sections 2.4 and 3.4 of cost increases due to delay and such cost increases are determined by City to be reasonable and are fully recovered through collected fees under the Financing Plan, funding will be insufficient to cover the cost increase. Therefore, Developer agrees to absorb any increase in Estimated Costs and/or interest thereon not accounted for in the Financing Plan (or future updates of the Financing Plan) because Developer failed to timely notify the City in writing as required under Sections 2.4 and 3.4.

2.7 City's Right to Terminate for Default.

2.7.1 If Developer fails to adequately perform any obligation required by this Agreement, Developer's failure shall constitute a Default. Unless within thirty (30) calendar days of receiving written notice from City specifying the nature of the Default Developer undertakes all reasonable efforts to ensure that the Default is completely remedied within a reasonable time period to the satisfaction of City, City may immediately terminate this Agreement including all rights of Developer and any person or entity claiming any rights by or through Developer under this

Agreement. A delay shall not constitute a Default if Developer has made good faith and reasonable efforts to adhere to the Project Schedule, has provided notice of delay in accordance with Section 2.4, and such delay was caused by unforeseen events that justify the delay as set forth in Section 2.5.

- 2.7.2 If City terminates the Agreement due to Developer's Default, City shall have the option to assume all of the rights of any and all contracts or subcontracts entered into by Developer or Developer's agents for the construction of the Project. Developer shall include, and require its contractors and subcontractors to include provisions in their contracts and subcontracts, that City is a third party beneficiary of the same and that City is entitled to and protected by the indemnities and warranties, whether written or express, contained therein.
- 2.7.3 The rights and remedies of City enumerated in Section 2.7 are cumulative and shall not limit, waive, or deny City's rights under other provisions of this Agreement, or waive or deny any right or remedy at law or in equity available to City against Developer, including any claims for damages against Developer that City may assert as a result of the Default.

- 2.8 **City's Right to Terminate for Bankruptcy or Assignment for the Benefit of Creditors.** If Developer files a voluntary petition in bankruptcy, is adjudicated bankrupt, or makes a general assignment for the benefit of creditors, City may at its option and without further notice to or demand upon Developer immediately terminate this Agreement, and terminate all rights of Developer and any person or entity claiming any rights by or through Developer. The rights and remedies of City enumerated in this Section are cumulative and shall not limit, waive, or deny any of City's rights or remedies under other provisions of this Agreement or those available at law or in equity.

ARTICLE III. PROJECT COSTS AND CHANGE ORDERS

- 3.1 **Project Costs.** Project Costs are Developer's reasonable costs of construction materials and design necessary for the Project as approved by the City and depicted in **Exhibit E**. Project Costs do not include Developer's Administrative costs (as defined in Section 3.3.1).
- 3.2 **Reimbursable Costs.** Developer may seek reimbursement only for Reimbursable Costs. Reimbursable Costs shall consist only of the Estimated Costs (as defined in Section 3.3) reasonably expended by Developer, approved for reimbursement in the Financing Plan, and approved by City under the terms of this Agreement.
- 3.2.1 ***Non-Reimbursable Costs.*** Non-Reimbursable Costs include: (i) Any cost in excess of the Maximum Funds; (ii) any cost in excess of the Estimated Costs not approved in accordance with Section 3.3.3; (iii) any cost identified in this Agreement as a Non-Reimbursable Cost; (iv) any cost to remedy Defective Work (as defined in Section 21.1); (v) any cost incurred as a result of Developer's or Developer's agents' negligence, omissions, delay, or Default; (vi) any cost of substituted products, work, or services not necessary for completion of the Project, unless requested and approved by City in writing; (vii) any cost not approved by City in the manner required by this Agreement and/or the Charter of

the City of San Diego (Charter) and rules, regulations, or laws promulgated thereunder; (viii) any cost not supported by proper invoicing or other documentation as reasonable and necessary; and (ix) any cost in excess of FBAs actually collected by the City and available for reimbursement to Developer for the design and construction of the Project. Additionally, the fair value as reasonably determined by City of any property that is destroyed, lost, stolen, or damaged rendering it undeliverable, unusable, or inoperable for City constitutes a Non-Reimbursable Cost. Refundable deposits, such as utility deposits, also constitute a Non-Reimbursable Cost.

3.3 Estimated Cost(s). Developer's Estimated Costs shall consist only of: (i) Project Costs, (ii) Developer's Administrative Costs (as defined in Section 3.3.1), and (iii) the Project Contingency (as defined in Section 3.3.2). The total Estimated Cost of Project is One Million Eight Hundred One Thousand Dollars (**\$1,801,000**), including interest (as set forth in Section 12.1.6).

3.3.1 *Developer's Administrative Costs.* Developer's Administrative Costs are reasonably incurred Project-related administration and supervision expenditures totaling a flat 5 percent of Developer's Project Costs.

3.3.2 *Project Contingency.* A Project Contingency of 10 percent of estimated construction costs is included in the Estimated Cost. The Project Contingency shall not be available for: (i) work required due to Developer's or Developer's agents' failure to perform work or services according to the terms of this Agreement or in compliance with the Construction Documents; or (ii) uninsured losses resulting from the negligence of Developer or Developer's agents.

3.3.3 *Change Orders and Adjustments to Estimated Cost.* Estimated Costs may be increased only through properly processed and approved Change Orders in accordance with **Exhibit I**. The Estimated Cost may only be increased if Developer provides documentation showing that the increase is reasonable in nature and amount, and is due to causes beyond Developer's or Developer's agents control or otherwise not the result of unreasonable conduct by Developer or Developer's agents which may, based on actual impact on the Project, include: war; changes in law or government regulation; later commonly accepted or adopted higher standards and specifications of construction; labor disputes or strikes; fires; floods; adverse weather or other similar condition of the elements necessitating temporary cessation of Developer's work; concealed conditions encountered in the completion of the Project; inability to reasonably obtain materials, equipment, labor, or additional required services; inflation; actual bids received for Project Costs being greater than estimated; or other specific reasons mutually agreed to in writing by City and Developer. Developer shall not be reimbursed, and no Change Order may be approved, for costs or expenses resulting from a design error or omission (unless such a design error or omission is the direct result of a City request for such design or omission), or Developer's or Developer's agents' negligence. Developer shall not have the right to terminate, reform, or abandon this Agreement for City's refusal to approve a Change Order.

- 3.4 **Notification of Increased Estimated Costs.** If Developer anticipates or has reason to believe that the cost of the Project will exceed the Estimated Cost, Developer shall notify the City in writing within fourteen (14) calendar days of becoming aware of the potential increase. If Developer fails to timely notify City in writing, Developer agrees to absorb any increase in Estimated Costs and any interest thereon not accounted for in the Financing Plan. This written notification shall include an itemized cost estimate and a list of recommended revisions Developer believes will bring the construction cost to an amount within the Estimated Cost. In accordance with Section 3.3.3, City may approve an increase in Estimated Costs and/or delineate a project which may be constructed within Estimated Costs. If City chooses not to pursue the above options, Developer may elect to construct the Project and forgo any reimbursement in excess of the Estimated Cost.

**ARTICLE IV. COMPETITIVE BIDDING,
EQUAL OPPORTUNITY AND EQUAL BENEFITS**

- 4.1 **Compliance.** Developer shall bid and award contracts to complete the Project in accordance with the Charter and rules, regulations, and laws promulgated thereunder, including, but not limited to, the San Diego Municipal Code (Municipal Code) and City Council resolutions and policies, as well as any expressly applicable public contract laws, rules, and regulations (Required Contracting Procedures). Required Contracting Procedures include all contracting requirements that are applicable to the City, including, but not limited to, competitive bidding, the City's small and local business program for public works contracts, and the City's Equal Benefits Ordinance. Prior to bidding the Project, Developer shall consult with City's Public Works Department. Developer shall work with City's Public Works Department to ensure that all Required Contracting Procedures are met. Developer may request that the City provide a letter regarding Developer's compliance with the Required Contracting Procedures, which shall in no way affect Developer's obligations under Article XVIII of this Agreement. Developer understands that it must comply with all Required Contracting Procedures. Failure to adhere to all Required Contracting Procedures is a material breach of this Agreement, and any contract awarded not in accordance with the Required Contracting Procedures shall be ineligible for reimbursement.
- 4.2 **Bidding Documents.** Following City review of the Construction Documents, Developer shall prepare final corrected Construction Documents to be submitted to City for review and approval, in accordance with City's standard review procedures prior to solicitation of bids.
- 4.2.1 ***Submission of Construction Documents.*** Developer shall submit bidding documents to City for approval before soliciting bids for work on the Project. The Developer may elect to prepare bidding documents requesting bids based on Lump Sum or Firm-Fixed prices or unit costs as applicable for each Project. City retains the right to notify Developer of necessary corrections and will notify Developer of corrections within fifteen (15) Working Days of submittal date.
- 4.2.2 ***Obtain all Permits and Approvals.*** Developer shall obtain all necessary permits, including, but not limited to, environmental, grading, building, mechanical,

electrical, and plumbing. Approval of Construction Documents will be evidenced by City's issuance of a letter indicating Developer may proceed with competitive bidding.

4.3 Solicitation of Bids. Developer shall solicit sealed bids for construction of the Project in accordance with all Required Contracting Procedures. With notice of at least five (5) Working Days, Developer shall notify City of the time and place of each bid opening. Developer shall work with City's Public Works Department to ensure that bids are solicited in the manner required in accordance with the Required Contracting Procedures.

4.4 Bid Opening and Award of Contract. Developer shall open bids and award contracts in accordance with all the Required Contracting Procedures. Developer shall work with City's Public Works Department to ensure that bids are opened and contracts are awarded in the manner required in accordance with the Required Contracting Procedures. Developer shall publicly open sealed bids in the presence of City's authorized representative(s). The bidding contractors shall be permitted to be present at the bid opening. City's representative(s) shall be provided with copies of all bids received immediately after the bid opening and with a copy of the tabulation of bid results upon Developer's completion. Contract(s) for the construction of the Project shall be awarded by Developer to the lowest responsible and reliable bidder in accordance with the Required Contracting Procedures.

4.4.1 In the event that the lowest responsible and reliable bid exceeds the Estimated Cost, any reimbursement for such an increase shall be subject to approval by Change Order pursuant to Section 3.3.3 following award of the contract.

4.4.1.1 In the event the City Council does not approve the increased cost, at City's option:

4.4.1.1.1 City may terminate this Agreement. In the event the Agreement is terminated, Developer's obligations pursuant to this Agreement for the construction of the Project shall be released without further liability. This release shall in no way affect the obligations of Developer with respect to any terms or conditions of the VTMs, Tentative Map(s), Development Agreements, or other approvals and agreements with City. However, prior to termination of this Agreement, City shall reimburse Developer (at City's option with either FBA credits or cash reimbursement) for the engineering and design costs reasonably incurred and expended by Developer in accordance with this Agreement and within the Estimated Cost in accordance with Section 3.3. Developer shall provide City with copies of all executed contracts; or

4.4.1.1.2 City may work with Developer to rebid and/or redesign the Project.

4.4.1.1.3 With Developer's consent, Developer may award the bid and assume responsibility for the costs in excess of Estimated Cost.

4.5 Nondiscrimination Requirements.

- 4.5.1 ***Compliance with the City's Equal Opportunity Contracting Program.*** Developer shall comply with City's Equal Opportunity Contracting Program. Developer shall not discriminate against any employee or applicant for employment on any basis prohibited by law. Developer shall provide equal opportunity in all employment practices. Developer shall ensure its consultants, contractors, and their subcontractors comply with the City's Equal Opportunity Contracting Program. Nothing in this Section shall be interpreted to hold the Developer liable for any discriminatory practice of its consultants, contractors or their subcontractors.
- 4.5.2 ***Nondiscrimination Ordinance.*** Developer shall not discriminate on the basis of race, gender, religion, national origin, ethnicity, sexual orientation, age, or disability in the solicitation, selection, hiring or treatment of consultants, contractors, subcontractors, vendors or suppliers. Developer shall provide equal opportunity for contractors and subcontractors to participate in contracting and subcontracting opportunities. Developer understands and agrees that violation of this clause shall be considered a material breach of the Agreement and may result in Agreement termination, debarment, and other sanctions. This language shall be in contracts between the Developer and any consultants, contractors, subcontractors, vendors and suppliers.
- 4.5.3 ***Compliance Investigations.*** Upon City's request, Developer agrees to provide to City, within sixty (60) calendar days, a truthful and complete list of the names of all consultants, contractors, subcontractors, vendors and suppliers Developer used in the past five years on any of its contracts undertaken within San Diego County, including the total dollar amount paid by Developer for each contract, subcontract or supply contract. The Developer further agrees to fully cooperate in any investigation conducted by City pursuant to City's Nondiscrimination in Contracting Ordinance (Municipal Code sections 22.3501-22.3517). Developer understands and agrees that violation of this clause shall be considered a material breach of the Agreement and may result in remedies being ordered against Developer up to and including Agreement termination, debarment, and other sanctions for violation of the provisions of the Nondiscrimination in Contracting Ordinance. Developer further understands and agrees that the procedures, remedies and sanctions provided for in the Nondiscrimination Ordinance apply only to violations of said Nondiscrimination Ordinance.
- 4.6 **Equal Benefits.** This Agreement is with a sole source and therefore, Developer is not subject to the City's Equal Benefits Ordinance, Chapter 2, Article 2, Division 43 of the Municipal Code. However, the Equal Benefits Ordinance is applicable to contracts that Developer enters into with respect to the Project. Therefore, Developer shall ensure that its contractor(s) and consultant(s) comply with the Equal Benefits Ordinance. Developer shall include in each of its contracts with its contractor(s) and consultant(s) provisions: (i) stating that the contractor(s) and/or consultant(s) must comply with the Equal Benefits Ordinance; (ii) stating that failure to maintain equal benefits is a material breach of those agreements; and (iii) requiring the contractor(s) and/or consultant(s) to certify that they will maintain equal benefits for the duration of the contract. Municipal Code § 22.4304(e)-(f). In addition, Developer's contractor(s) and/or consultant(s) must comply with the requirement that they not discriminate in the provision of benefits between

employees with spouses and employees with domestic partners, and that it notify employees of the equal benefits policy at the time of hire and during open enrollment periods during the performance of the contract. Municipal Code § 22.4304(a)-(b). Developer's contractor(s) and/or consultant(s) must also provide the City with access to documents and records sufficient for the City to verify compliance with the Equal Benefits Ordinance requirements. Municipal Code § 22.4304(c). Additionally, Developer's contractor(s) and/or consultant(s) may not use a separate entity to evade the requirements of the Equal Benefits Ordinance. Municipal Code § 22.4304(d). Developer shall ensure that its contractor(s) and consultant(s) complete the Equal Benefits Ordinance Certification of Compliance included as an example herein as **Exhibit J**.

ARTICLE V. PREVAILING WAGE

5.1 Prevailing Wage. Prevailing wages apply to the Project. Pursuant to San Diego Municipal Code section 22.3019, construction, alteration, demolition, repair and maintenance work performed on the Project is subject to State prevailing wage laws, and Developer shall ensure compliance with all applicable prevailing wage laws and requirements. For construction work performed on the Project that cumulatively exceeds \$25,000 and for alteration, demolition, repair and maintenance work performed on the Project that cumulatively exceeds \$15,000, Developer shall ensure that its contractors and subcontractors comply with State prevailing wage laws including, but not limited to, the requirements listed below.

5.1.1 Compliance with Prevailing Wage Requirements. Pursuant to sections 1720 through 1861 of the California Labor Code, Developer shall ensure that its contractors and subcontractors ensure that all workers who perform work on the Project are paid not less than the prevailing rate of per diem wages as determined by the Director of the California Department of Industrial Relations (DIR). This includes work performed during the design and preconstruction phases of construction including, but not limited to, inspection and land surveying work.

5.1.1.1 Copies of such prevailing rate of per diem wages are on file at the City and are available for inspection to any interested party on request. Copies of the prevailing rate of per diem wages also may be found at <http://www.dir.ca.gov/OPRL/DPreWageDetermination.htm>. Developer shall ensure that its contractors and subcontractors post a copy of the prevailing rate of per diem wages determination at each job site and make them available to any interested party upon request.

5.1.1.2 The wage rates determined by the DIR refer to expiration dates. If the published wage rate does not refer to a predetermined wage rate to be paid after the expiration date, then the published rate of wage shall be in effect for the life of contract for the Project. If the published wage rate refers to a predetermined wage rate to become effective upon expiration of the published wage rate and the predetermined wage rate is on file with the DIR, such predetermined wage rate shall become effective on the date following the expiration date and shall apply to the contract in the same manner as if it had been published in said publication. If the predetermined wage rate refers to one or more additional expiration dates with additional predetermined wage rates, which expiration dates occur during the life of the contract, each successive predetermined wage rate shall apply to the contract on the date following the

expiration date of the previous wage rate. If the last of such predetermined wage rates expires during the life of the contract, such wage rate shall apply to the balance of the contract.

5.1.2 Penalties for Violations. Developer shall ensure that its contractor and subcontractors comply with California Labor Code section 1775 in the event a worker is paid less than the prevailing wage rate for the work or craft in which the worker is employed.

5.1.3 Payroll Records. Developer shall ensure that its contractor and subcontractors comply with California Labor Code section 1776, which generally requires keeping accurate payroll records, verifying and certifying payroll records, and making them available for inspection. Developer shall require its contractor to require its subcontractors to also comply with section 1776. Developer shall ensure that its contractor and subcontractors submit weekly certified payroll records online via the City's web-based Labor Compliance Program. Developer shall ensure that its contractor ensures its subcontractors submit certified payroll records to the City.

5.1.3.1 For contracts entered into on or after April 1, 2015, Developer shall ensure that its contractor and subcontractors furnish records specified in California Labor Code section 1776 directly to the Labor Commissioner in the manner required by California Labor Code section 1771.4.

5.1.4 Apprentices. Developer shall ensure that its contractors and its subcontractors comply with California Labor Code sections 1777.5, 1777.6 and 1777.7 concerning the employment and wages of apprentices. Developer shall ensure that its contractors are held responsible for the compliance of their subcontractors with sections 1777.5, 1777.6 and 1777.7.

5.1.5 Working Hours. Developer shall ensure that its contractors and subcontractors comply with California Labor Code sections 1810 through 1815, including but not limited to: (i) restricting working hours on public works contracts to eight hours a day and forty hours a week, unless all hours worked in excess of 8 hours per day are compensated at not less than 1½ times the basic rate of pay; and (ii) specifying penalties to be imposed on design professionals and subcontractors of \$25 per worker per day for each day the worker works more than 8 hours per day and 40 hours per week in violation of California Labor Code sections 1810 through 1815.

5.1.6 Required Provisions for Subcontracts. Developer shall ensure that its contractors include at a minimum a copy of the following provisions in any contract they enter into with a subcontractor: California Labor Code sections 1771, 1771.1, 1775, 1776, 1777.5, 1810, 1813, 1815, 1860, and 1861.

5.1.7 Labor Code Section 1861 Certification. Developer shall ensure, in accordance with California Labor Code section 3700, that its contractors are required to secure the payment of compensation of its employees and by signing the contract, the contractors certify as follows: "I am aware of the provisions of Section 3700 of the California Labor Code which require every employer to be insured against liability for workers' compensation or to undertake

self-insurance in accordance with the provisions of that code, and I will comply with such provisions before commencing the performance of the work of this [agreement or contract].”

5.1.8 Labor Compliance Program. The City has its own Labor Compliance Program authorized in August 2011 by the DIR. The City will withhold contract payments when payroll records are delinquent or deemed inadequate by the City or other governmental entity, or it has been established after an investigation by the City or other governmental entity that underpayment(s) have occurred. For questions or assistance, please contact the City of San Diego’s Equal Opportunity Contracting Department at 619-236-6000.

5.1.9 Department of Industrial Relations Registration. This Project is subject to compliance monitoring and enforcement by the DIR. As of March 1, 2015, no contractor or subcontractor may be listed on a bid or proposal for a public works project unless registered with the DIR pursuant to California Labor Code section 1725.5. As of April 1, 2015, a contractor or subcontractor shall not be qualified to bid on, be listed in a bid proposal, or enter into any contract for public work, unless currently registered and qualified to perform public work pursuant to California Labor Code section 1725.5. Developer shall ensure that its calls for bids and contract documents include the following provisions: “No contractor or subcontractor may be listed on a bid proposal for a public works project (submitted on or after March 1, 2015) unless registered with the Department of Industrial Relations pursuant to Labor Code section 1725.5 [with limited exceptions from this requirement for bid purposes only under Labor Code section 1771.1(a)]”; “No contractor or subcontractor may be awarded a contract for public work on a public works project (awarded on or after April 1, 2015) unless registered with the Department of Industrial Relations pursuant to Labor Code section 1725.5”; and “This project is subject to compliance monitoring and enforcement by the Department of Industrial Relations;” ; and “By submitting a bid or proposal, Contractor is certifying that he or she has verified that all subcontractors used on this public work project are registered with the DIR in compliance with California Labor Code sections 1771.1 and 1725.5, and Contractor shall provide proof of registration to the City upon request.”

5.1.9.1 A contractor’s inadvertent error in listing a subcontractor who is not registered pursuant to California Labor Code section 1725.5 in response to a solicitation shall not be grounds for filing a bid protest or grounds for considering the bid non-responsive provided that any of the following apply: (1) the subcontractor is registered prior to bid opening; (2) within twenty-four hours after the bid opening, the subcontractor is registered and has paid the penalty registration fee specified in California Labor Code section 1725.5; or (3) the subcontractor is replaced by another registered subcontractor pursuant to Public Contract Code section 4107.

ARTICLE VI. CONSULTANTS

- 6.1 **Selection of Consultant.** Developer's hiring of a consultant is subject to City's approval. Developer's consultants shall be subject to all State and City laws, including regulations and policies applicable to consultants retained directly by City. Developer shall cause the provisions in **Exhibit K** "Consultant Provisions" to be included in its consultant contract(s) for the Project. The selection of any consultant is subject to all applicable public contract laws, rules, and regulations, including but not limited to, the City Charter, the Municipal Code, Council Policies, and the City's Administrative Regulations. Developer shall work with City's Public Works Department to ensure that City's consultant selection procedures are met. Developer understands that it must comply with all consultant selection procedures applicable to the City unless a waiver of those procedures is obtained. Failure to adhere to all applicable consultant selection procedures is a material breach of this Agreement, and any contract awarded not in accordance with the City's consultant selection procedures shall be ineligible for reimbursement.

Provided that San Diego Ordinance No. 00-20519 is finally passed, the consultant selection requirements for the selection of the following consultants are waived: (1) Latitude 33 Planning and Engineering for civil engineering; (2) SJA Inc. and Mark Lloyd for landscape architecture and land planning; (3) MJS Construction for management and engineering; (4) Urban Systems Associates, Inc. for traffic engineering; (5) Utility Specialists Southwest, Inc. for public utility services; (6) KCM Group for project management; and (7) Geocon Consultants, Inc. for geotechnical engineering.

- 6.2 **Equal Benefits and Nondiscrimination.** The requirements of City's Equal Benefits Ordinance apply to Developer's consultant contracts. *See* Section 4.6. The nondiscrimination requirements in Section 4.5 apply to Developer's consultant contracts.
- 6.3 **Estimated Budget.** Developer shall require its consultant to prepare an estimated budget for the Project.
- 6.4 **Schematic Drawings.** Developer shall require its consultant to prepare schematic drawings for the Project for City approval.

ARTICLE VII. DESIGN AND CONSTRUCTION STANDARDS

- 7.1 **Standard of Care.** Developer agrees that the professional services provided under this Agreement shall be performed in accordance with the standards customarily adhered to by experienced and competent professional design, architectural, engineering, landscape architecture, and construction firms using the degree of care and skill ordinarily exercised by reputable professionals practicing in the same field of service in the State of California.
- 7.2 **Compliance with all Laws, Design Standards, and Construction Standards.** In all aspects of the design and construction of the Project, Developer shall comply with all laws and the most current editions of the Green Book, the City's Standard Drawings and Design and Construction Standards, including those listed in **Exhibit L**. It shall be Developer's sole responsibility to comply with the Americans with Disabilities Act and Title 24 of the California Building Standards Code, California Code of Regulations. Developer shall certify compliance with Title 24/ADA to City in the form and content as set forth on **Exhibit M**, "Certification for Title 24/ADA Compliance."

- 7.3 **Imputed Knowledge.** Developer shall be responsible for all amendments or updates to Design and Construction Standards and knowledge of all amendments or updates to Design and Construction Standards, whether local, state, or federal, and such knowledge will be imputed to Developer to the fullest extent allowed by law.
- 7.4 **City Approval.** Developer shall be required to obtain City approval of design, plans, and specifications in the manner required in **Exhibit N**. Unless specifically provided otherwise, whenever this Agreement requires an action or approval by City, that action or approval shall be performed by the duly authorized City representative designated by this Agreement.
- 7.5 **City Approval Not a Waiver of Obligations.** Where approval by City, the Mayor, or other representatives of City is required, it is understood to be general approval only and does not relieve Developer of responsibility for complying with all applicable laws, codes, regulations and good consulting, design, or construction practices.

ARTICLE VIII. CONSTRUCTION AND DRUG-FREE WORKPLACE

- 8.1 **Compliance with Project Schedule and Construction Requirements.** Developer shall commence construction of the Project in accordance with the Project Schedule, as described in Article II, and be subject to the obligations in **Exhibit O**, "Construction Obligations." Developer shall diligently pursue such construction to completion. Failure to maintain the Project Schedule constitutes a Default subject to Section 2.7. The rights and remedies of City enumerated in this Section are cumulative and shall not limit, waive, or deny any of City's rights or remedies under any other provision of this Agreement or those available at law or in equity.
- 8.2 **Drug-Free Workplace.** Developer agrees to comply with City's requirements in Council Policy 100-17, "DRUG-FREE WORKPLACE", adopted by San Diego Resolution R-277952 and fully incorporated into this Agreement by reference. The Developer shall certify to City that it will provide a drug-free workplace by submitting a Developer Certification for a Drug-Free Workplace in the form and content of **Exhibit P**. Developer shall ensure that its contractors comply with the requirements of City's Council Policy 100-17.

ARTICLE IX. PRODUCTS

- 9.1 **Product Submittal and Substitution.** To the extent product specification is not addressed by the most recent edition of the Standard Specifications for Public Works Construction (including the City of San Diego's standard special provisions) (Green Book) or the Project has aesthetic aspects requiring City review, comment, and approval, prior to the bidding process, Developer shall obtain City approval of products and substitution of products in the manner provided in **Exhibit Q**, "Product Submittal and Substitution."
- 9.1.1 ***Not a Release of Liability.*** City's review of samples in no way relieves Developer of Developer's responsibility for construction of the Project in full compliance with all Construction Documents.

ARTICLE X. EXTRA WORK

- 10.1 **City Authority to Order Extra Work.** Any City additions or modifications to work or Developer obligations under this Agreement not described within City-approved Construction Documents (Extra Work) may be ordered by City prior to completion pursuant to the terms and conditions listed in **Exhibit R**, "Extra Work Provisions."

ARTICLE XI. CHANGED CONDITIONS

- 11.1 **Changed Conditions.** Changed Conditions shall have the meaning as defined in the Green Book. The Parties acknowledge and agree that even if Changed Conditions are found to be present, the Project shall not exceed the Estimated Cost without express City Council approval of an increase to the Estimated Cost in accordance with Section 3.3.3. Absent such express approval of additional funds, Developer shall provide City with value engineering and the Parties shall return the Project to within the Estimated Cost.

ARTICLE XII. REIMBURSEMENT

12.1 **Reimbursement to Developer**

- 12.1.1 ***Notification of Reimbursable Project.*** Along with the Project's construction permit application to the City's Development Services Department, and prior to commencement of any work on the Project, Developer shall submit a "Notification of Reimbursable Project" form (attached as **Exhibit S**) to Planning, Neighborhoods & Economic Development Department, Facilities Financing.
- 12.1.2 ***Type of Reimbursement.*** Developer shall be entitled to cash reimbursement, or FBA credits, for the Reimbursable Costs expended by Developer and approved by City in accordance with this Agreement and the Financing Plan. The Financing Plan currently has the Estimated Cost scheduled for reimbursement beginning in or after Fiscal Year 2013. Any changes to the timing of reimbursement shall be reflected in future updates to the Financing Plan without further amendment to this Agreement. Developer shall not receive cash reimbursement unless there are sufficient funds to reimburse Developer, in whole or in part, from the FBA. If sufficient funds are unavailable in the FBA, City shall reimburse Developer only if and as funds accrue in the FBA for the Project. Where FBA credits are requested and approved by City, credit reimbursement shall be made in accordance with the schedule in the Financing Plan. Developer acknowledges and agrees that in the event there are no additional FBA funds available for collection by City to fund the Project, Developer shall not be reimbursed by City for any portion of Developer's outstanding costs or expenditures, and Developer expressly agrees to fully absorb all such outstanding costs or expenditures without any reimbursement from City.
- 12.1.3 ***Funds for Reimbursement.*** Developer shall only be entitled to reimbursement as set forth in this Agreement and only from FBA funds collected by City in accordance with the Financing Plan, as it may be amended, in the amount set forth in this Agreement and only as allocated for the Project, if and as such funds become available for the Project, after the appropriate deductions and

expenditures are made, pursuant to the method of reimbursement described in Section 12.1.7, and in the priority of reimbursement described in Section 12.1.11.

- 12.1.4 **Amount of Reimbursement.** Developer shall be eligible for reimbursement for Reimbursable Costs in accordance with Section 3.2 in an amount not to exceed Estimated Costs in accordance with Section 3.3.
- 12.1.5 **City's Administrative Costs.** City's Administrative Costs shall be paid prior to any reimbursement to Developer and shall consist of the costs and expenses incurred by City to: (i) implement, process, and administer the Project, (ii) review contractor/subcontractor compliance with the City's Required Contracting Procedures, (iii) approve reimbursable costs for work performed during design/construction through Final Completion of the Project, (iv) review project documentation to verify all costs related to the Project, inclusive of construction bid tabulations, contracts, and review of any cost allocation methods (City's Administrative Costs).
- 12.1.6 **Interest.** Interest shall begin to accrue from 90 days after the time the submittal of a Reimbursement Request (as defined in Section 12.1.7) is accepted and approved by the City, or the date the Developer submits an invoice for approved amounts in accordance with Section 12.1.10, whichever occurs later, and shall continue to accrue until either the date FBA credits are made available for Developer's use or the date of cash reimbursement, whichever occurs first up to a maximum of \$ 50,000. Interest shall accrue at the rate earned by the City Treasurer on funds allocated for the Project, not to exceed the assumed interest rate identified in the assumptions of the applicable Financing Plan, at the time the interest is accruing. Interest shall not accrue under circumstances set forth in Sections 2.6 and 3.4. Interest shall not accrue on the withholding amount set forth in Section 12.1.8.
- 12.1.7 **Method of Reimbursement.** Developer shall submit to City a written request for reimbursement for all Reimbursable Costs incurred or advanced for the Project for which Developer was not previously reimbursed or granted FBA credit (Reimbursement Request). Reimbursement Requests for projects other than those covered by this Agreement must be submitted as separate requests. The Reimbursement Request must also include all relevant documents in accordance with this Section. City shall determine whether additional documentation is needed to support the Reimbursement Request or if the Reimbursement Request is otherwise incomplete, and shall notify Developer of such deficiencies within sixty (60) calendar days of Developer's Reimbursement Request submittal. Developer shall provide additional documentation within fourteen (14) calendar days of City's notification and request. However, even if City fails to notify Developer within sixty (60) calendar days regarding Developer's Reimbursement Request, City may continue to request additional documentation to support the Reimbursement Request and shall not be obligated to reimburse Developer until City confirms receipt of all relevant documentation sufficient to support the Reimbursement Request. After all appropriate cost documentation has been received and City approves the Reimbursement Request (Reimbursement Request Approval), City shall reimburse Developer for those Reimbursable Costs within sixty (60) calendar days of the date of Reimbursement Request Approval provided that funds are

available in the FBA for the Project, and that the Project is scheduled in the Financing Plan for reimbursement at that time.

12.1.8 **Reimbursement Timing.** Subject to the limitations of Article XII, and at the City's discretion, provided that Reimbursement Requests have been approved for the below amounts, Developer shall be entitled to reimbursement as follows:

- 12.1.8.1 Up to 25 percent of the total Estimated Costs (\$1,801,000) for the Project subject to the Developer satisfying all of the following requirements:
- All plans and specifications for the Project have been approved by the City, and
 - Any right-of-way required for the Project has been secured and dedicated, and
 - All required permits and environmental clearances necessary for the Project have been secured, and
 - All performance bonds, payment bonds, and warranty bonds as described in Article XVIII have been provided, and
 - All City fees and costs have been paid, and
 - Evidence satisfactory to the City that Developer has complied with and satisfied Article IV (Competitive Bidding, Equal Opportunity, and Equal Benefits) and Article VI (Consultants) of the Agreement.
- 12.1.8.2 Up to 50 percent of the total Estimated Costs (\$1,801,000) for the Project subject to Developer satisfying all of the above-referenced requirements for the 25 percent reimbursement, and Developer has received valid bids for the Project, which have been approved by the City, and has awarded the construction contract. Such reimbursement shall be based on the Reimbursable Costs.
- 12.1.8.3 Up to 90 percent of the Reimbursable Costs reasonably expended for the Project subsequent to City's issuance of a Substantial Completion Letter (as defined in Section 15.1) for the Project.
- 12.1.8.4 The remaining 10 percent of the Reimbursable Costs reasonably expended shall be paid to Developer subsequent to Final Completion (as defined in Section 16.1). Developer

12.1.9 **Cutoff for Submission of Reimbursement Requests.** Developer shall submit all Reimbursement Requests within six (6) months after the Final Completion or within six months of the date that environmental monitoring occurred if the submittal is related to such environmental monitoring (Cutoff Date). Any Reimbursement Request submitted after the Cutoff Date shall constitute a Non-Reimbursable Cost and Developer shall not be eligible or entitled for any reimbursement for those costs or expenses.

- 12.1.10 ***Verification of Reimbursement Request.*** Developer shall on a monthly basis, or as otherwise required by the City in writing, provide reasonably organized documentation to support the Reimbursement Request including, but not limited to, proof that all mechanic liens have been released, copies of invoices received and copies of cancelled checks, substitute checks, or image replacement documents showing that payment has been made in connection with the Reimbursement Request in the following manner:
- 12.1.10.1 Developer shall submit one (1) copy of a Reimbursement Request Form (**Exhibit T**) with supporting documentation for work completed in accordance with this Agreement and the Plans and Specifications and/or Extra Work.
 - 12.1.10.2 Prior to the approval of the Reimbursement Request, the RE shall verify whether the materials and work for which reimbursement is being requested have been installed and performed as represented. The RE shall review the Project on-site for quality of material and assurance and adherence to the bid list, contract estimates, and the Plans and Specifications. The RE shall also review as-builts and Best Management Practices (BMPs), and verify that a lien release has been prepared.
 - 12.1.10.3 The RE shall initial the reimbursement Request, noting any disallowed costs, maintain a copy, and forward the original to the City Senior Civil Engineer or City designee for review and approval.
 - 12.1.10.4 The City Senior Civil Engineer or City designee shall review the Reimbursement Request, as well as supporting cost documentation received from Developer, including soft costs related to the Project, as well as monitor the RE's expenses charged to the Project, and other City Administrative Costs. The City Senior Civil Engineer or City designee shall also serve as the liaison between the RE and the Facilities Financing Project Manager (FF Project Manager).
 - 12.1.10.5 After review and approval of the Reimbursement Request, the City Senior Civil Engineer or City designee shall forward to the FF Project Manager for review and approval. Following approval, the FF Project Manager shall return the request to the Senior Civil Engineer or City designee.
 - 12.1.10.6 The City Senior Civil Engineer or City designee shall prepare a memorandum, including a summary schedule of budgeted and actual approved costs, to the FF Project Manager recommending the reimbursement amount including all construction invoices and change orders previously approved, and soft costs incurred to date, noting any costs to be disallowed and the reason for the disallowance. A copy of the memorandum shall be forwarded to Developer.

- 12.1.10.7 The FF Project Manager shall verify that reimbursements are scheduled in the Financing Plan and verify FBA cash/credits are available for reimbursement.
- 12.1.10.8 Developer shall then submit an invoice to the City for the reimbursement amount approved by City.
- 12.1.11 ***Priority of Reimbursement.*** Reimbursement to Developer from the FBA for the Project will be subsequent to reimbursement of City's equipment purchases, Furniture Fixtures & Equipment (FF&E), and City's Administrative Expenses incurred in connection with the Project or Financing Plan and FBA, but takes priority over any Developer Reimbursable Project added to the Financing Plan subsequent to the Effective Date (as defined in Section 26.1) of this Agreement, with the following exceptions:
 - 12.1.11.1 Any State or Federally mandated project.
 - 12.1.11.2 Appropriations for City administered, managed, and funded Capital Improvement Projects.
 - 12.1.11.3 To the extent Developer failed to properly notify City in writing of any actual or anticipated increases in Estimated Costs as required under Sections 2.6 and 3.4, the reimbursement for the cost increases, if approved by City, will be subsequent in priority to those projects with agreements approved by the City Council prior to the City Council's approval of increased Estimated Costs.
 - 12.1.11.4 The Financing Plan identifies other project(s) for funding in an earlier fiscal year than this Project prior to the Effective Date of this Agreement.

ARTICLE XIII. PUBLIC RELATIONS

- 13.1 **Presentations.** Developer and Developer's agents shall be available for all presentations required to be made to City Council, Council Committees, any other related committees, and citizen groups to provide them with information about the Project as well as presentations to any governing or regulatory body or agency for other approvals as may be required.
- 13.2 **City as Primary Contact.** Developer agrees that City is the primary contact with the media regarding the Project and Developer shall forward all questions regarding the Project status to the Responsible Department's Senior Public Information Officer.
- 13.3 **Advertising.** Developer acknowledges that advertising referring to City as a user of a product, material, or service by Developer and/or Developer's agents, material suppliers, vendors or manufacturers is expressly prohibited without City's prior written approval.
- 13.4 **Recognition.** Developer shall place a sign, placard, or other similar monument on the Project site during construction, which shall acknowledge Developer's and City's joint efforts in designing and constructing the Project, and identifying that the Project is funded with FBA funds. Developer shall properly recognize City and include the City of San Diego's logo on permanent and temporary signs, invitations, flyers, or other

correspondence. Any recognition of City shall be reviewed and approved by the Responsible Department's Senior Public Information Officer. For assistance with proper recognition, or if Developer is contemplating a dedication or ground breaking ceremony, Developer shall contact the Responsible Department's Senior Public Information Officer.

- 13.5 Dedication Ceremony.** City or Developer shall have the opportunity to conduct and host a public dedication ceremony, ground-breaking, or similar ceremony on the Project site at any reasonable time following Operational Acceptance of the Project, provided Developer receives prior approval from the Public Works Department for the ceremony and provides an opportunity for appearances by the Mayor, Council Members and other appropriate City officials. Developer shall contact the Responsible Department's Senior Public Information Officer to arrange a mutually acceptable date and time for any ceremony. Invitation shall not be sent out or a date set until the Responsible Department's Senior Public Information Officer has approved the time and date for the ceremony.
- 13.6 Cleanup.** Developer shall be responsible for the cleanup of the Project site and the restoration and repair of any damage to the Project site attributable to any Developer sponsored ceremony.

ARTICLE XIV. INSPECTION

- 14.1 Inspection Team.** The Project shall be inspected by a team composed of representatives from (i) the City's Resident Engineer, (ii) the Responsible Department, (iii) City's Development Services Department, (iv) Developer's consultant(s), and (v) Developer's construction superintendent (Inspection Team).

ARTICLE XV. SUBSTANTIAL COMPLETION

- 15.1 Substantial Completion Letter.** When Developer determines that the Project is substantially complete, Developer shall request an operational inspection and letter of Substantial Completion Letter from the Resident Engineer. The Substantial Completion Letter shall include the Field Engineering Division's inspection of the improvements. The Substantial Completion Letter only authorizes public utilization of the Project in accordance with Sections 6-8 "Completion, Acceptance, and Warranty," and 6-10 "Use of Improvements during Construction" of the Greenbook. The Substantial Completion Letter does not constitute City approval for Final Completion of the punch list or as-built plans.

ARTICLE XVI. FINAL COMPLETION

- 16.1 Final Completion.** Final Completion shall not occur until each of the following is satisfied. Approval for the Final Completion for the work required to complete the Project shall occur upon the later of the following:
- 16.1.1 Documents and Approvals.** Submission and approval of all documents required to be supplied by Developer to City pursuant to this Agreement, including As-Built Drawings, As-Graded Reports, warranties, operating and maintenance manuals and other Project Deliverables identified in **Exhibit U**; City signature

and sign off as final approval on all grading or public right-of-way permits; and if applicable, the issuance of a final Certificate of Occupancy for the Project.

16.1.2 **Capitalization.** The Developer shall submit a capitalization form with respect to the Project in a form acceptable to the FF Project Manager. An example is provided as **Exhibit V**.

16.1.3 **Lien and Material Releases.** Developer shall ensure that all contractors and subcontractors provide lien and material releases for the Project and provide copies of such lien and material releases to the City Engineer. Alternatively, with City's approval, which shall not be unreasonably withheld, Developer may ensure that bonds are provided in a form reasonably acceptable to City in lieu of the lien and material releases.

16.2 **No Waiver.** Developer's obligation to perform and complete the Project in accordance with this Agreement and Construction Documents shall be absolute. Neither recommendation of any progress payment or acceptance of the work, nor any payment by City to Developer under this Agreement, nor any use or occupancy of the Project or any part thereof by City, nor any act of acceptance by City, nor any failure to act, nor any review of a shop drawing or sample submittal will constitute an acceptance of work which is not in accordance with the Construction Documents.

16.3 **Assignment of Rights.** Upon Final Completion of the Project, Developer shall assign its rights under its contracts with all contractors, subcontractors, design professionals, engineers, and material suppliers associated with the Project to City. Developer shall be required to obtain written approval and acknowledgement, whether in the form of a contract provision or separate document, of such assignment from its contractors, subcontractors, design professionals, engineers, and material suppliers. This assignment of rights shall not relieve Developer of its obligations under this Agreement, and such obligations shall be joint and several.

16.4 **Ownership of Project Deliverables.** Upon Final Completion or termination, Project Deliverables shall become City's property. Developer and City mutually agree that this Agreement, Construction Documents, and Project Deliverables for the Project shall not be used on any other work without the consent of each Party.

ARTICLE XVII. BONDS AND OTHER ACCEPTABLE SECURITIES

17.1 **Payment Bond.** Developer shall provide or require its construction contractor to provide City with a payment bond, letter of credit (LOC), cash or other acceptable security for material and labor in favor of City for 100 percent of the proposed construction costs, as determined by competitive bidding (Payment Bond).

17.2 **Performance Bond.** Developer shall provide or require its construction contractor to provide City with a bond, LOC, cash or other acceptable security guaranteeing the performance in favor of City for 100 percent of the proposed construction costs, as determined by competitive bidding (Performance Bond).

- 17.3 **Warranty Bond.** Developer shall provide or require its construction contractor to provide City with a bond, LOC, cash or other acceptable security guaranteeing the Project during the warranty period in favor of City (Warranty Bond). Developer shall provide the Warranty Bond to City upon release of the Performance Bond or commencement of the warranty periods, whichever occurs first.
- 17.4 **Term.** The Payment Bond shall remain in full force and effect until Final Completion to ensure that all claims for materials and labor are paid, except as otherwise provided by law or regulation. The Performance Bond shall remain in full force and effect until Operational Acceptance of the Project by City. Upon Operational Acceptance, City shall follow the procedures outlined in California Government Code section 66499.7 and release the Performance Bond. The Warranty Bond shall remain in full force and effect for the warranty periods provided in this Agreement.
- 17.5 **Certificate of Agency.** All bonds signed by an agent must be accompanied by a certified copy of such agent's authority to act.
- 17.6 **Licensing and Rating.** The bonds shall be duly executed by a responsible surety company admitted to do business in the State of California, licensed or authorized in the jurisdiction in which the Project is located to issue bonds for the limits required by this Agreement, and have a minimum AM Best rating of "A-" to an amount not to exceed 10 percent of its capital and surplus.
- 17.7 **Insolvency or Bankruptcy.** If the surety on any bond furnished by the construction contractor is declared bankrupt or becomes insolvent or its right to do business is terminated in any state where any part of the Project is located, Developer shall within seven (7) calendar days thereafter substitute or require the substitution of another bond or other acceptable security, acceptable to City.

ARTICLE XVIII. INDEMNIFICATION

- 18.1 **Indemnification and Hold Harmless Agreement.** Other than in the performance of design professional services which shall be solely as addressed in Sections 18.2 and 18.3 below, to the fullest extent permitted by law, Developer shall defend (with legal counsel reasonably acceptable to the City), indemnify and hold harmless the City and its officers, agents, departments, officials, and employees (Indemnified Parties) from and against all claims, losses, costs, damages, injuries (including, without limitation, injury to or death of an employee of Developer or Developer's agents), expense and liability of every kind, nature and description (including, without limitation, incidental and consequential damages, court costs, attorney's fees, litigation expenses and fees of expert consultants or expert witnesses incurred in connection therewith and costs of investigation) that arise out of, pertain to, or relate to, directly or indirectly, in whole or in part, any services performed under this Agreement by Developer or Developer's agents, any subcontractor, anyone directly or indirectly employed by them, or anyone they control. Developer's duty to defend, indemnify, protect and hold harmless shall not include any claims or liabilities arising from the active negligence, sole negligence or willful misconduct of the Indemnified Parties.
- 18.2 **Indemnification for Design Professional Services.** To the fullest extent permitted by law (including, without limitation, California Civil Code section 2782.8), with respect to

the performance of design professional services, Developer shall require its design professional to indemnify and hold harmless the City, its officers, and employees, from all claims, demands, or liability that arise out of, pertain to, or relate to the negligence, recklessness, or willful misconduct of Developer's design professional or design professional's officers or employees.

- 18.3 Design Professional Services Defense.** The Parties will work in good faith to procure applicable insurance coverage for the cost of any defense arising from all claims, demands or liability that arise out of, pertain to or relate to the negligence, recklessness, or willful misconduct of design professional or design professional's officers or employees.
- 18.4 Insurance.** The provisions of this Article are not limited by the requirements of Article XIX related to insurance.
- 18.5 Enforcement Costs.** Developer agrees to pay any and all costs City incurs enforcing the indemnity and defense provisions set forth in this Article.
- 18.6 Indemnification for Liens and Stop Notices.** Developer shall keep the Project and underlying property free of any mechanic's liens and immediately secure the release of any stop notices. Developer shall defend, indemnify, protect, and hold harmless, City, its agents, officers and employees from and against any and all liability, claims, costs, and damages, including but not limited to, attorney fees, arising from or attributable to a failure to pay claimants. Developer shall be responsible for payment of all persons entitled to assert liens and stop notices.

ARTICLE XIX. INSURANCE

- 19.1 General.** Developer shall not begin work on the Project under this Agreement until it has: (i) obtained, and upon City's request provided to City, insurance certificates reflecting evidence of all insurance required in this Article; (ii) obtained City approval of each company or companies; and (iii) confirmed that all policies contain specific provisions required by City pursuant to this Article.
- 19.2 Type and Amount of Insurance.** The City Attorney shall confer with the City's risk management department and determine the appropriate dollar amount and type of insurance, including any endorsements or specific clauses, necessary for the Project (Required Insurance). Developer shall obtain the Required Insurance prior to the commencement of construction. City's standard insurance provisions are attached as **Exhibit W**. If Developer is not informed otherwise in writing of Required Insurance, City's standard insurance provisions included in **Exhibit W** shall be the Required Insurance for the Project.
- 19.3 Written Notice.** Except as provided for under California law, any Required Insurance shall not be canceled, non-renewed or materially changed except after thirty (30) calendar days prior written notice by Developer to City by certified mail, except for non-payment of premium, in which case ten (10) calendar days notice shall be provided.
- 19.3.1 Where the words "will endeavor" and "but failure to mail such notice shall impose no obligation or liability of any kind upon the company, its agents, or representatives" are present on a certificate, they shall be deleted.

- 19.4 **Rating Requirements.** Except for the State Compensation Insurance Fund, all insurance required by express provision of this Agreement shall be carried only by responsible insurance companies that have been given at least an “A” or “A-” and “VI” rating by AM BEST, that are authorized by the California Insurance Commissioner to do business in the State of California, and that have been approved by City.
- 19.5 **Non-Admitted Carriers.** City will accept insurance provided by non-admitted, “surplus lines” carriers only if the carrier is authorized to do business in the State of California and is included on the List of Eligible Surplus Lines Insurers.
- 19.6 **Additional Insurance.** Developer may obtain additional insurance not required by this Agreement.
- 19.7 **Obligation to Provide Documents.** Prior to performing any work on the Project, Developer shall provide copies of documents including, but not limited to, certificates of insurance and endorsements, and shall furnish renewal documentation prior to expiration of insurance. Each required document shall be signed by the insurer or a person authorized by the insurer to bind coverage on its behalf. City reserves the right to require complete, certified copies of all insurance policies required herein.
- 19.8 **Deductibles/Self Insured Retentions.** All deductibles and self-insurance retentions on any policy shall be the responsibility of Developer. Deductibles and self-insurance retentions shall be disclosed to City at the time the evidence of insurance is provided.
- 19.9 **Policy Changes.** Developer shall not modify any policy or endorsement thereto which increases City’s exposure to loss for the duration of this Agreement.
- 19.10 **Reservation of Rights.** City reserves the right, from time to time, to review the Developer’s insurance coverage, limits, deductible and self insured retentions to determine if they are acceptable to City. City will reimburse the Developer for the cost of the additional premium for any coverage-requested by City in excess of that required by this Agreement without overhead, profit, or any other markup.
- 19.11 **Not a Limitation of Other Obligations.** Insurance provisions under this Article shall not be construed to limit Developer’s obligations under this Agreement, including indemnity.
- 19.12 **Material Breach.** Failure to maintain, renew, or provide evidence of renewal of required insurance during the term of this Agreement, and for a period of ten (10) years from the Effective Date of this Agreement, may be treated by City as a material breach of this Agreement.

ARTICLE XX. WARRANTIES

- 20.1 **Warranties Required.** Developer shall require the construction contractor and its subcontractors and agents to provide the warranties listed below. This warranty requirement is not intended to exclude, and shall not exclude, other implicit or explicit warranties or guarantees required or implied by law. All such warranties shall be enforceable by and inure to the benefit of City.
- 20.1.1 ***Materials and Workmanship.*** All work on the Project shall be guaranteed against defective workmanship and all materials furnished by the construction contractor or its agents shall be guaranteed against defects for a period of one (1) year from

the date of the Project's Final Completion. Construction contractor shall replace or repair or require its agents to replace or repair any such Defective Work or materials in a manner satisfactory to City, after notice to do so from City, and within the time specified in the notice.

20.1.2 ***New Materials and Equipment.*** Construction contractor shall warrant and guarantee, and shall require its agents to warrant and guarantee, that all materials and equipment incorporated into the Project are new unless otherwise specified.

20.1.3 ***Design, Construction, and Other Defects.*** Construction contractor shall warrant and guarantee, and shall require its agents to warrant and guarantee, that all work is in accordance with the Plans and Specifications and is not defective in any way in design, construction, or otherwise.

20.2 Form and Content. Except manufacturer's standard printed warranties, all warranties shall be on Developer's and Developer's agents, material supplier's, installer's or manufacturer's own letterhead, addressed to City. All warranties shall be submitted in the format specified in this Section.

20.2.1 ***Durable Binder.*** Obtain warranties, executed in triplicate by Developer, Developer's agents, installers, and manufacturers. Provide table of contents and assemble in binder with durable plastic cover.

20.2.2 ***Table of Contents.*** All warranties shall be listed and typewritten in the sequence of the table of contents of the Project manual, with each item identified with the number and title of the specification section in which specified, and the name of product or work item.

20.2.3 ***Index Tabs.*** Each warranty shall be separated with index tab sheets keyed to the table of contents listing.

20.2.4 ***Detail.*** Provide full information, using separate typewritten sheets, as necessary. List Developer's agents, installer, and manufacturer, with name, address and telephone number of responsible principal.

20.2.5 ***Warranty Start Date.*** This date shall be left blank until the date of Final Completion.

20.2.6 ***Signature and Notarization.*** All warranties shall be signed and notarized. Signatures shall be required from Developer's construction contractor and where appropriate, the responsible subcontractor.

20.3 Term of Warranties. Unless otherwise specified or provided by law, all warranties, including those pertaining to plants, trees, shrubs and ground cover, shall extend for a term of one (1) year from the date of Final Completion.

20.4 Meetings. During the one (1) year warranty period described in Section 20.3, Developer shall meet and shall require its design consultant, construction contractor, and key subcontractors to meet, with City representatives, including the Public Works Project Manager and one or more Responsible Department representatives, on a monthly basis, if requested by City. This meeting shall be held to discuss and resolve any problems City discovers in design, construction, or furnishing, fixtures, and equipment of the Project during the one (1) year warranty period.

ARTICLE XXI. DEFECTIVE WORK

- 21.1 Correction, Removal, or Replacement.** All work, material, or equipment that is unsatisfactory, faulty, incomplete, or does not conform to the Construction Documents is defective (Defective Work). If within the designated warranty period, or such additional period as may be required by law or regulation, the Project is discovered to contain Defective Work, Developer shall promptly and in accordance with City's written instructions and within the reasonable time limits stated therein, either correct the Defective Work, or if it has been rejected by City, remove it from the site and replace it with non-defective and conforming work.
- 21.2 City's Right to Correct.** If circumstances warrant, including an emergency or Developer's failure to adhere to Section 21.1, City may correct, remove, or replace the Defective Work. In such circumstances, Developer shall not recover costs associated with the Defective Work and shall reimburse City for all City's costs, whether direct or indirect, associated with the correction or removal and replacement.
- 21.3 Defects Constitute Non-Reimbursable Costs.** All costs incurred by Developer or Developer's agents to remedy Defective Work are Non-Reimbursable Costs. If City has already reimbursed Developer for Defective Work, City is entitled to an appropriate decrease in Reimbursable Costs, to withhold a setoff against the amount, or to make a claim against Developer's or the construction contractor's bond if Developer has been paid in full.
- 21.4 Extension of Warranty.** When Defective Work, or damage therefrom, has been corrected, removed, or replaced during the warranty period, the one (1) year, or relevant warranty period, shall be extended for an additional one (1) year from the date of the satisfactory completion of the correction, removal, or replacement.
- 21.5 No Limitation on other Remedies.** Exercise of the remedies for Defective Work pursuant to this Article shall not limit the remedies City may pursue under this Agreement, at law, or in equity.
- 21.6 Resolution of Disputes.** If Developer and City are unable to reach agreement on disputed work, City may direct Developer to proceed with the work and compensate Developer for undisputed amounts. Payment of disputed amounts shall be as later determined by mediation or as subsequently adjudicated or established in a court of law. Developer shall maintain and keep all records relating to disputed work in accordance with Article XXIII.
- 21.7 Prior to Final Acceptance and Reimbursement to the Developer.** Where Defective Work has been identified prior to the Final Completion of the Project, Developer shall promptly, and in accordance with City's written instructions and within the reasonable time limits stated therein, either correct the Defective Work, or if it has been rejected by City, remove it from the site and replace it with non-defective and conforming work. Costs incurred to remedy Defective Work are Non-Reimbursable Costs. Where Defective Work is not remedied, City is entitled to an appropriate decrease in Reimbursable Costs, to withhold a setoff against the amount paid, or make a claim against the Developer's or construction contractor's bond.

ARTICLE XXII. MAINTENANCE OF LANDSCAPING & IRRIGATION WORK

- 22.1 Maintenance Period.** If the construction contractor is required to install or maintain landscaping and/or irrigation, Developer shall require the construction contractor to provide a maintenance period to begin on the first day after all landscape and irrigation work on the Project is complete, checked, approved by City, and City has given written approval to begin the maintenance period, and shall continue until ninety (90) calendar days after the date of Final Completion or ninety (90) calendar days after the date the landscaping and irrigation is accepted, whichever is longer. The maintenance period shall be 120 calendar days if turf is seeded.
- 22.2 Maintenance Area.** Developer shall require the construction contractor to maintain all areas of the Project, including areas impacted or disturbed by the Project.
- 22.3 Maintenance Required.** Developer shall require the construction contractor to conduct regular planting maintenance operations immediately after each plant is planted. Plants shall be kept in a healthy growing condition and in a visually pleasing appearance by watering, pruning, mowing, rolling, trimming, edging, fertilizing, restaking, pest and disease controlling, spraying, weeding, cleaning up and any other necessary operation of maintenance. Landscape areas shall be kept free of weeds, noxious grass and all other undesired vegetative growth and debris. Construction contractor shall replace all plants found to be dead or in an impaired condition within fourteen (14) calendar days. Maintenance shall also include the following: (i) filling and replanting of any low areas that may cause standing water (ii) adjusting of sprinkler head height and watering pattern, (iii) filling and recompaction of eroded areas, (iv) weekly removal of trash, litter, clippings and foreign debris, (v) inspecting plants at least twice per week, and (vi) protecting all planting areas against traffic or other potential causes of damage.
- 22.4 Landscape and Irrigation Inspection.** At the conclusion of the maintenance period, City shall inspect the landscaping and irrigation to determine the acceptability of the work, including maintenance. This inspection shall be scheduled with two (2) weeks notice, a minimum of eighty (80) calendar days after the plant maintenance period commencement, or when Developer or Developer's contractor notifies City they are ready for the Final Inspection, whichever comes last. The City will notify Developer of all deficiencies revealed by the inspection before acceptance.
- 22.5 Extension of Maintenance Period.** Developer shall require the construction contractor to extend completion of the maintenance period when in City's opinion improper maintenance and/or possible poor or unhealthy condition of planted material is evident at the termination of the scheduled maintenance period. Developer shall require the construction contractor to accept responsibility for additional maintenance of the work until all of the work is completed and acceptable. Additional costs for failure to maintain landscaping during the maintenance period are Non-Reimbursable Costs.
- 22.6 Replacement.** Plants found to be dead or not in a vigorous condition, or if root balls have been damaged, within the installation, maintenance and guarantee periods, shall be replaced within fourteen (14) calendar days of notification by City. Developer shall require the construction contractor to include, at construction contractor's expense, a timely written diagnosis of plant health by a certified arborist, should a dispute arise. An arborist's report shall indicate the reason for lack of vigor, potential remedies, if any, and an estimate of the time required to regain vigor and specified size. Plants used for

replacement shall be of the same kind and size as specified and shall be furnished, planted and fertilized as originally specified, unless otherwise directed in writing by City. Developer shall require the cost of all repair work to existing improvements damaged during replacements be borne by the construction contractor. Costs of replacement are Non-Reimbursable Costs.

ARTICLE XXIII. RECORDS AND AUDITS

- 23.1 Retention of Records.** Developer, consultants, contractors, and subcontractors shall maintain data and records related to this Project and Agreement for a period of not less than five (5) years following the Effective Date of this Agreement.
- 23.2 Audit of Records.** At any time during normal business hours and as often as City deems necessary, Developer and all contractors or subcontractors shall make available to City for examination at reasonable locations within the City/County of San Diego all of the data and records with respect to all matters covered by this Agreement. Developer and all contractors or subcontractors shall permit City to make audits of all invoices, materials, payrolls, records of personnel, and other data and media relating to all matters covered by this Agreement. If records are not made available within the City/County of San Diego, then Developer shall pay all City's travel-related costs to audit the records associated with this Agreement at the location where the records are maintained. All such costs are Non-Reimbursable Costs.
- 23.2.1 Costs.** Developer and Developer's agents shall allow City to audit and examine books, records, documents, and any and all evidence and accounting procedures and practices that City determines are necessary to discover and verify all costs of whatever nature, which are claimed to have been incurred, anticipated to be incurred, or for which a claim for additional compensation or for Extra Work have been submitted under this Agreement.

ARTICLE XXIV. NOTICES

- 24.1 Writing.** Any demand upon or notice required or permitted to be given by one Party to the other Party shall be in writing.
- 24.2 Effective Date of Notice.** Except as otherwise provided by law, any demand upon or notice required or permitted to be given by one Party to the other Party shall be effective: (i) on personal delivery, (ii) on the second business day after mailing by certified or registered U.S. Mail, Return Receipt Requested, (iii) on the succeeding business day after mailing by Express Mail or after deposit with a private delivery service of general use (e.g., Federal Express) postage or fee prepaid as appropriate, or (iv) upon documented successful transmission of facsimile.
- 24.3 Recipients.** All demands or notices required or permitted to be given to City or Developer shall be delivered to all of the following:
- 24.3.1 Director, Public Works Department
City of San Diego
525 B Street, Suite 750 (M.S. #908A)
San Diego, California 92101

Facsimile: (619) 533-5176

24.3.2 Facilities Financing Manager
Planning Department
City of San Diego
1010 Second Avenue, Suite 600 (M.S. #606F)
San Diego, California 92101
Facsimile: (619) 533-3687

24.3.3 Ms. Beth Fischer
Pardee Homes
Division President-San Diego
6025 Edgewood Bend Court
San Diego, CA 92130
Facsimile: 858.794.2599

Thomas F. Steinke, Esq.
Seltzer Caplan McMahon Vitek
750 B Street, Suite 2100
San Diego, CA 92101
Facsimile: 619.702.6819

24.4 **Change of Address(es)**. Notice of change of address shall be given in the manner set forth in Article XXIV.

ARTICLE XXV. MEDIATION

25.1 **Mandatory Mediation**. If dispute arises out of, or relates to the Project or this Agreement, or the breach thereof, and if said dispute cannot be settled through normal contract negotiations, prior to the initiation of any litigation, the Parties agree to attempt to settle the dispute in an amicable manner, using mandatory mediation under the Construction Industry Mediation Rules of the American Arbitration Association (AAA) or any other neutral organization agreed upon before having recourse in a court of law.

25.2 **Mandatory Mediation Costs**. The expenses of witnesses for either side shall be paid by the Party producing such witnesses. All other expenses of the mediation, including required traveling and other expenses of the mediator (Mediator), and the cost of any proofs or expert advice produced at the direct request of the Mediator, shall be borne equally by the Parties, unless they agree otherwise.

25.3 **Selection of Mediator**. A single Mediator that is acceptable to both Parties shall be used to mediate the dispute. The Mediator will be knowledgeable in construction aspects and may be selected from lists furnished by the AAA or any other agreed upon Mediator. To initiate mediation, the initiating Party shall serve a Request for Mediation on the opposing Party. If the Mediator is selected from a list provided by AAA, the initiating Party shall concurrently file with AAA a "Request for Mediation" along with the

appropriate fees, a list of three requested Mediators marked in preference order, and a preference for available dates.

25.3.1 If AAA is selected to coordinate the mediation (Administrator), within fourteen calendar days from the receipt of the initiating Party's Request for Mediation, the opposing Party shall file the following: a list of preferred Mediators listed in preference order after striking any Mediators to which they have any factual objection, and a preference for available dates. If the opposing Party strikes all of initiating Party's preferred Mediators, opposing Party shall submit a list of three preferred Mediators listed in preference order to initiating Party and Administrator. Initiating Party shall file a list of preferred Mediators listed in preference order, after striking any Mediator to which they have any factual objection. This process shall continue until both sides have agreed upon a Mediator.

25.3.2 The Administrator will appoint or the Parties shall agree upon the highest, mutually preferred Mediator from the individual Parties' lists who is available to serve within the designated time frame.

25.3.3 If the Parties agree not to use AAA, then a Mediator, date and place for the mediation shall be mutually agreed upon.

25.4 Conduct of Mediation Sessions. Mediation hearings will be conducted in an informal manner and discovery will not be allowed. All discussions, statements, or admissions will be confidential to the Party's legal position. The Parties may agree to exchange any information they deem necessary.

25.4.1 Both Parties must have an authorized representative attend the mediation. Each representative must have the authority to recommend entering into a settlement. Either Party may have attorney(s) or expert(s) present. Upon reasonable demand, either Party may request and receive a list of witnesses and notification whether attorney(s) will be present.

25.4.2 Any agreements resulting from mediation shall be documented in writing. All mediation results and documentation, by themselves, shall be "non-binding" and inadmissible for any purpose in any legal proceeding, unless such admission is otherwise agreed upon, in writing, by both Parties. Mediators shall not be subject to any subpoena or liability and their actions shall not be subject to discovery.

ARTICLE XXVI. MISCELLANEOUS PROVISIONS

26.1 Term of Agreement. Following the adoption of the City Council ordinance authorizing this Agreement and the subsequent execution of the same by the Parties, this Agreement shall be effective upon the date it is executed by the City Attorney in accordance with Charter section 40 (Effective Date). Unless otherwise terminated, the Agreement shall be effective until (i) the final reimbursement payment is made; or (ii) one year after the Warranty Bond terminates, whichever is later, but not to exceed five years unless approved by City ordinance.

- 26.2 **Construction Documents.** Construction documents include, but are not limited to: construction contract, contract addenda, notice inviting bids, instructions to bidders, bid (including documentation accompanying bid and any post-bid documentation submitted prior to notice of award), the bonds, the general conditions, permits from other agencies, the special provisions, the plans, standard plans, standard specifications, reference specifications, and all modifications issued after the execution of the construction contract.
- 26.3 **Headings.** All article headings are for convenience only and shall not affect the interpretation of this Agreement.
- 26.4 **Gender & Number.** Whenever the context requires, the use herein of (i) the neuter gender includes the masculine and the feminine genders, and (ii) the singular number includes the plural number.
- 26.5 **Reference to Paragraphs.** Each reference in this Agreement to a Section refers, unless otherwise stated, to a Section of this Agreement.
- 26.6 **Incorporation of Recitals.** All Recitals herein are true and correct to the Parties' best knowledge and belief, and are fully incorporated into this Agreement by reference and are made a part hereof.
- 26.7 **Covenants and Conditions.** All provisions of this Agreement expressed as either covenants or conditions on the part of City or Developer shall be deemed to be both covenants and conditions.
- 26.8 **Integration.** This Agreement and all Exhibits and references incorporated into this Agreement fully express all understandings of the Parties concerning the matters covered in this Agreement. No change, alteration, or modification of the terms or conditions of this Agreement, and no verbal understanding of the Parties, their officers, agents, or employees shall be valid unless made in the form of a written change agreed to in writing by both Parties or a written amendment to this Agreement agreed to by both Parties. All prior negotiations and agreements are merged into this Agreement.
- 26.9 **Severability.** The unenforceability, invalidity, or illegality of any provision of this Agreement shall not render any other provision of this Agreement unenforceable, invalid, or illegal.
- 26.10 **Drafting Ambiguities.** The Parties acknowledge they each have been fully advised by their own counsel with respect to the negotiations, terms, and conditions of this Agreement. This Agreement shall not be construed in favor of or against either Party by reason of the extent to which each Party participated in the drafting of the Agreement.
- 26.11 **Conflicts Between Terms.** If an apparent conflict or inconsistency exists between the main body of this Agreement and the Exhibits, the main body of this Agreement shall control. If a conflict exists between an applicable federal, state, or local law, rule, regulation, order, or code and this Agreement, the law, rule, regulation, order, or code shall control. Varying degrees of stringency among the main body of this Agreement, the exhibits, and laws, rules, regulations, orders, or codes are not deemed conflicts, and the most stringent requirement shall control. Each Party shall notify the other immediately upon the identification of any apparent conflict or inconsistency concerning this Agreement.

- 26.12 Prompt Performance.** Time is of the essence of each covenant and condition set forth in this Agreement.
- 26.13 Good Faith Performance.** The Parties shall cooperate with each other in good faith, and assist each other in the performance of the provisions of this Agreement.
- 26.14 Further Assurances.** City and Developer each agree to execute and deliver such additional documents as may be required to effectuate the purposes of this Agreement.
- 26.15 Exhibits.** Each of the Exhibits referenced and attached to this Agreement is fully incorporated herein by reference.
- 26.16 Compliance with Controlling Law.** Developer shall require its consultants, contractors, subcontractors, agents, and employees to comply with all laws, statutes, resolutions, ordinances, regulations, and policies of the federal, state, and local governments applicable to this Agreement (and if expressly made applicable by the City Council, California Labor Code section 1720 as amended in 2000 relating to the payment of prevailing wages during the design and preconstruction phases of Project), including inspection and land surveying work. In addition, Developer shall require its consultants, contractors, subcontractors, agents, and employees comply immediately with all directives issued by City or its authorized representatives under authority of any laws, statutes, resolutions, ordinances, rules, regulations or policies.
- 26.17 Hazardous Materials.** Hazardous Materials constitute any hazardous waste or hazardous substance as defined in any federal, state, or local statute, ordinance, rule, or regulation applicable to Property, including, without limitation the Comprehensive Environmental Response, Compensation, and Liability Act of 1980, as amended (42 U.S.C. §§ 9601-9675), the Resource Conservation and Recovery Act (42 U.S.C. §§ 6901-6992k), the Carpenter Presley-Tanner Hazardous Substance Account Act (California Health and Safety Code sections 25300-25395.15), and the Hazardous Waste Control Law (California Health and Safety Code sections 25100-25250.25). Developer agrees to comply with all applicable state, federal and local laws and regulations pertaining to Hazardous Materials.
- 26.18 Jurisdiction, Venue, and Choice of Law.** The venue for any suit or proceeding concerning this Agreement, including the interpretation or application of any of its terms or any related disputes, shall be in the County of San Diego, State of California. This Agreement is entered into and shall be construed and interpreted in accordance with the laws of the State of California.
- 26.19 Municipal Powers.** Nothing contained in this Agreement shall be construed as a limitation upon the powers of the City as a chartered city of the State of California.
- 26.20 Third-Party Relationships.** Nothing in this Agreement shall create a contractual relationship between City and any third-party; however, the Parties understand and agree that City, to the extent permitted by law, is an intended third-party beneficiary of all Developer's contracts, purchase orders and other contracts between Developer and third-party services. Developer shall incorporate this provision into its contracts, supply agreements and purchase orders.
- 26.21 Non-Assignment.** The Developer shall not assign the obligations under this Agreement, whether by express assignment or by sale of the company, nor any monies due or to

become due, without City's prior written approval. Any assignment in violation of this Section shall constitute a Default and is grounds for immediate termination of this Agreement, at the sole discretion of City. In no event shall any putative assignment create a contractual relationship between City and any putative assignee.

- 26.22 Successors in Interest.** This Agreement and all rights and obligations created by this Agreement shall be in force and effect whether or not any Parties to the Agreement have been succeeded by another entity, and all rights and obligations created by this Agreement shall be vested and binding on any Party's successor in interest.
- 26.23 Independent Contractors.** The Developer, any consultants, contractors, subcontractors, and any other individuals employed by Developer shall be independent contractors and not agents of City. Any provisions of this Agreement that may appear to give City any right to direct Developer concerning the details of performing the work or services under this Agreement, or to exercise any control over such performance, shall mean only that Developer shall follow the direction of City concerning the end results of the performance.
- 26.24 Approval.** Where the consent or approval of a Party is required or necessary under this Agreement, the consent or approval shall not be unreasonably withheld; however, nothing in this Section shall in any way bind or limit any future action of the City Council pertaining to this Agreement or the Project.
- 26.25 No Waiver.** No failure of either City or Developer to insist upon the strict performance by the other of any covenant, term, or condition of this Agreement, nor any failure to exercise any right or remedy consequent upon a breach of any covenant, term, or condition of this Agreement, shall constitute a waiver of any such breach of such covenant, term or condition. No waiver of any breach shall affect or alter this Agreement, and each and every covenant, condition, and term hereof shall continue in full force and effect to any existing or subsequent breach.
- 26.26 Signing Authority.** The representative for each Party signing on behalf of a corporation, partnership, joint venture or governmental entity hereby declares that authority has been duly obtained to sign on behalf of the corporation, partnership, joint venture, or entity and agrees to hold the other Party or Parties hereto harmless if it is later determined that such authority does not exist.
- 26.27 Remedies.** Notwithstanding any other remedies available to City at law or in equity, Developer understands that its failure to comply with the insurance requirements or other obligations required by this Agreement, and/or submitting false information in response to these requirements, may result in withholding reimbursement payments until Developer complies and/or may result in suspension from participating in future city contracts as a developer, prime contractor or consultant for a period of not less than one (1) year. For additional or subsequent violations, the period of suspension may be extended for a period of up to three (3) years.

IN WITNESS WHEREOF, this agreement is executed by the City of San Diego, acting by the through its Mayor, pursuant to Ordinance No. 00-20519 _____, authorizing such execution, and by Developer.

This Agreement was approved by the City Attorney this 23 of November, 2015, and this date shall constitute the Effective Date of this Agreement.

THE CITY OF SAN DIEGO, a Municipal Corporation

Dated: 11/19/15

By: David Graham

Approved:
JAN I. GOLDSMITH, City Attorney

Dated: 11/23/2015

By: Jan I. Goldsmith

PARDEE HOMES, a California corporation

Dated: 6.30.15

By: J. A.

Or.Dept: PLN-Facilities Financing

EXHIBIT A

[Financing Plan Project Sheet for Project No. T-4.2]

EXHIBIT B

[Depiction of Project]

EXHIBIT C

[Description of Project]

EXHIBIT D

[Project Schedule]

EXHIBIT E

[Estimated Cost]

EXHIBIT F

[Project Schedule Obligations and Components]

EXHIBIT G

[Meeting Requirements]

EXHIBIT H

[Preconstruction, Progress, & Special Meeting Agenda]

EXHIBIT I

[Procedure for Processing Change Orders]

EXHIBIT J

[Equal Benefits Ordinance Certification of Compliance]

EXHIBIT K

[Consultant Provisions]

EXHIBIT L

[Design and Construction Standards]

EXHIBIT M

[Certification for Title 24/ADA Compliance]

EXHIBIT N

[Approval of Design, Plans, and Specifications]

EXHIBIT O

[Construction Obligations]

EXHIBIT P

[Certification for a Drug-Free Workplace]

EXHIBIT Q

[Product Submittal and Substitution]

EXHIBIT R

[Extra Work Provision]

EXHIBIT S

[Notification of Reimbursable Project]

EXHIBIT T

[Reimbursement Request Form]

EXHIBIT U

[Project Deliverables]

EXHIBIT V

[Sample Capitalization Form]

EXHIBIT W

[Typical Insurance Provisions]

EXHIBIT A
Financing Plan Project Sheet

CITY OF SAN DIEGO
FACILITIES FINANCING PROGRAM

TITLE: CARMEL VALLEY ROAD (4/6 lanes south of Del Mar Heights Road)

DEPARTMENT: ENGINEERING & CAPITAL PROJECTS
CIP, JO, or WBS #: 52-733.0/S-00900

PROJECT: T-4.2
COUNCIL DISTRICT: 1
COMMUNITY PLAN: PHR

SOURCE	FUNDING	EXPENDED	CONT APPROP	FY 2013	FY 2014	FY 2015	FY 2016	FY 2017
FBA-PHR	\$7,085,000	\$3,410,239	\$1	\$741,949		\$2,932,812		
FBA-BMR								
FBA-TH								
FBA-DMM								
FBA-RP								
DEV. ADV		\$3,692,812	-\$18,051	-\$741,949		-\$2,932,812		
DEV/SUBD								
COUNTY								
STATE								
OTHER								
UNIDEN								
TOTAL	\$7,085,000	\$7,103,051	-\$18,051	\$0	\$0	\$0	\$0	\$0

SOURCE	FY 2018	FY 2019	FY 2020	FY 2021	FY 2022	FY 2023	FY 2024	FY 2025
FBA-PHR								
FBA-BMR								
FBA-TH								
FBA-DMM								
FBA-RP								
DEV. ADV								
DEV/SUBD								
COUNTY								
STATE								
OTHER								
UNIDEN								
TOTAL	\$0	\$0	\$0	\$0	\$0	\$0	\$0	\$0



CONTACT: LINDA MARABIAN

TELEPHONE: (619) 533-3082

EMAIL: LMarabian@sandiego.gov

CITY OF SAN DIEGO
FACILITIES FINANCING PROGRAM

TITLE: CARMEL VALLEY ROAD (4/6 lanes south of Del Mar Heights Road)

DEPARTMENT: ENGINEERING & CAPITAL PROJECTS
CIP, JO, or WBS #: 52-733.0/S-00900

PROJECT: T-4.2
COUNCIL DISTRICT: 1
COMMUNITY PLAN: PHR

DESCRIPTION:

DESIGN AND CONSTRUCT CARMEL VALLEY ROAD FROM THE CAMINO SANTA FE INTERCHANGE TO DEL MAR HEIGHTS ROAD AS A SIX-LANE FACILITY WITHIN A 146 FOOT RIGHT-OF-WAY TRANSITIONING TO A FOUR LANE FACILITY WITHIN A 122 FOOT RIGHT-OF-WAY (4,000 LF). THE EXPANDED RIGHT-OF-WAY WILL PERMIT WIDENING OF UP TO 24 ADDITIONAL FEET FOR A FUTURE TRANSIT ORIENTED FACILITY. IN THE INTERIM, THESE TWO LANES ARE LANDSCAPED AND INCORPORATED INTO THE CENTER MEDIAN IMPROVEMENTS.

REFERENCE:

TORREY HIGHLANDS PUBLIC FACILITIES FINANCING PLAN PROJECT T-4.5

JUSTIFICATION:

DUE TO ANTICIPATED TRAFFIC VOLUMES ON CARMEL VALLEY ROAD, THE REACH BETWEEN SR-56 AND DEL MAR HEIGHTS ROAD WILL BE CONSTRUCTED AS A SIX LANE FACILITY, IN TWO PHASES, AS REQUIRED BY THE TRANSPORTATION PHASING PLAN.

FUNDING ISSUES:

DEVELOPER (PARDEE) ADVANCED FUNDING FOR THIS PROJECT AND WILL BE REIMBURSED FROM THE PACIFIC HIGHLANDS RANCH FACILITIES BENEFIT ASSESSMENT UNDER THE TERMS OF A REIMBURSEMENT AGREEMENT.

NOTES:

THIS PROJECT WILL BE CONSTRUCTED IN TWO PHASES. THE FIRST PHASE BUILT 4 LANES WITHIN A GRADED RIGHT OF WAY FOR 6 LANES. THE SECOND PHASE WILL CONSTRUCT 2 LANES WITHIN THE MEDIAN TO EXPAND FROM 4 LANES TO 6 LANES IN ACCORDANCE WITH THE TRANSPORTATION PHASING PLAN. THIS PROJECT IS A PORTION OF THE TOTAL IMPROVEMENTS FOR CARMEL VALLEY ROAD WITHIN PACIFIC HIGHLANDS RANCH. SEE COMPANION PROJECTS T-4.3 AND T-4.4 FOR THE OTHER PORTIONS OF THIS PROJECT.

SCHEDULE:

PHASE I IS COMPLETED. PHASE II WILL OCCUR AS REQUIRED BY THE TRANSPORTATION AND FACILITIES PHASING PLAN.

CONTACT: LINDA MARABIAN

TELEPHONE: (619) 533-3082

EMAIL: LMarabian@sandiego.gov

EXHIBIT B
Depiction of Project

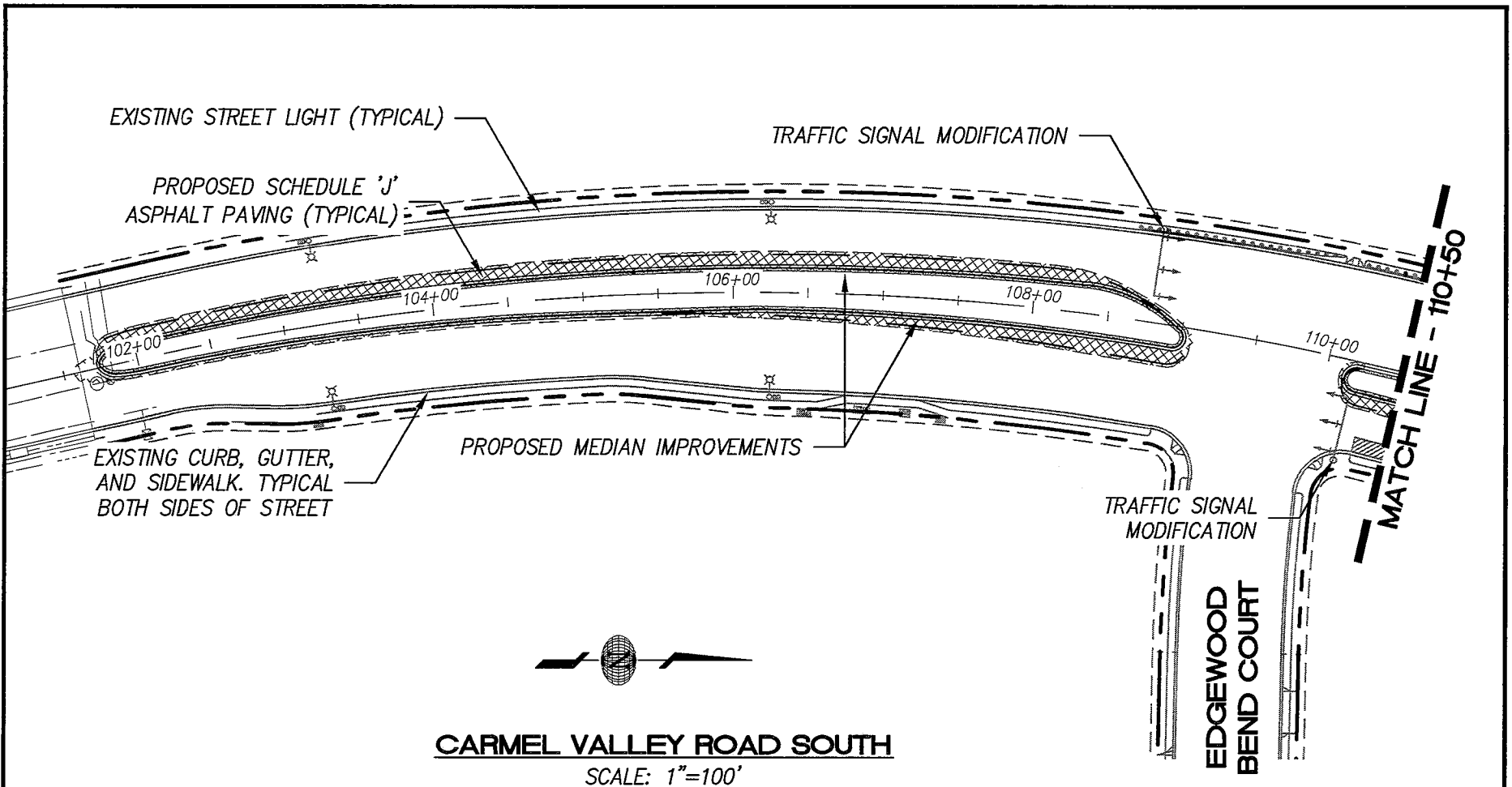

EXHIBIT 'B-2'

CARMEL VALLEY ROAD SOUTH
DRAWING NO. 38352-D

SCALE: 1"=100'
DATE: OCT. 2, 2014 DRAWN BY: IL
JOB NO.: 633.60 CHECKED BY:

latitude 33
PLANNING & ENGINEERING
9968 Hibert Street 2nd Floor, San Diego, CA 92131
Tel 858.751.0633

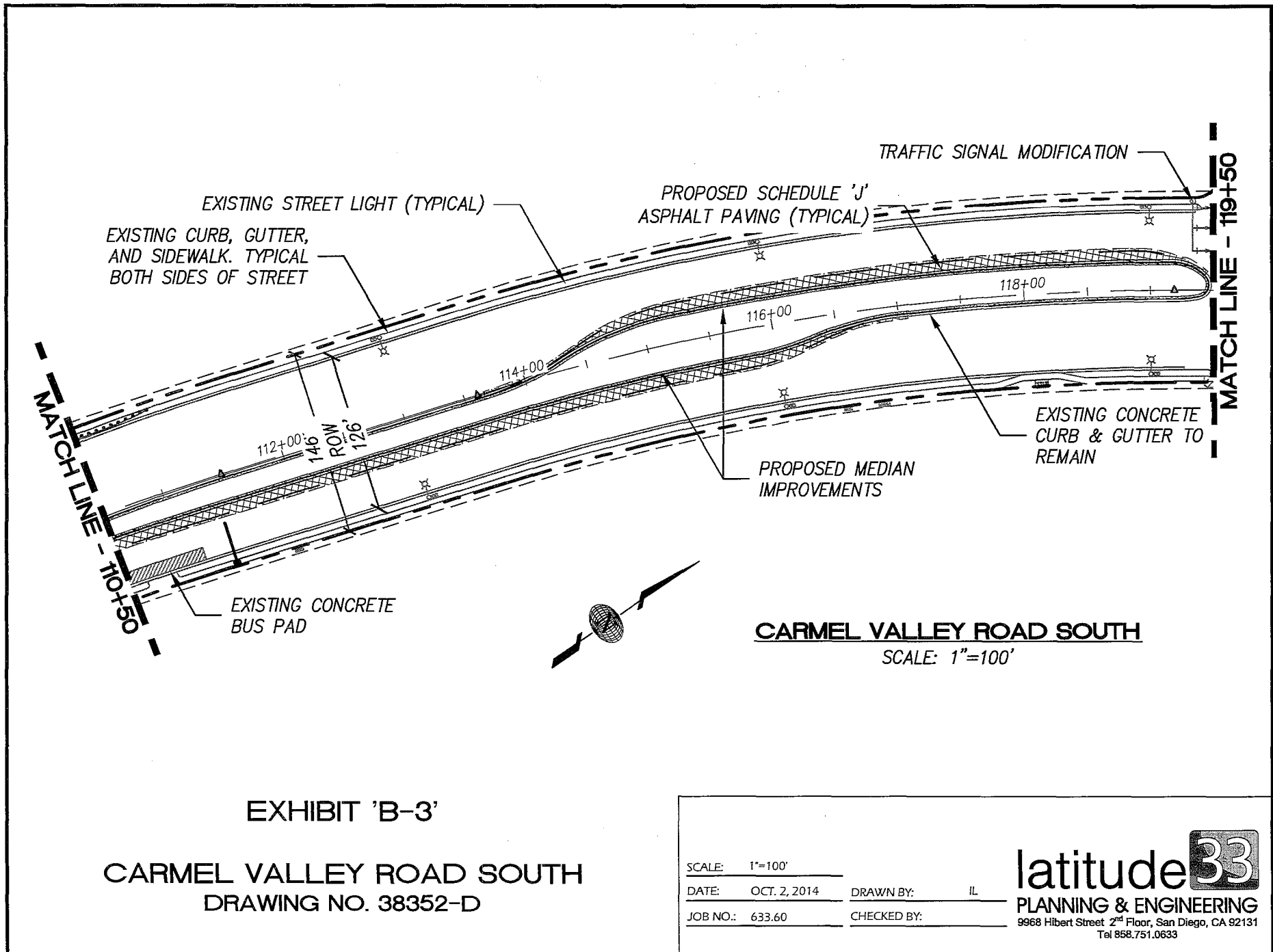
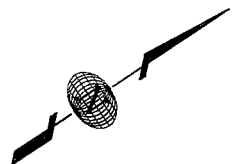
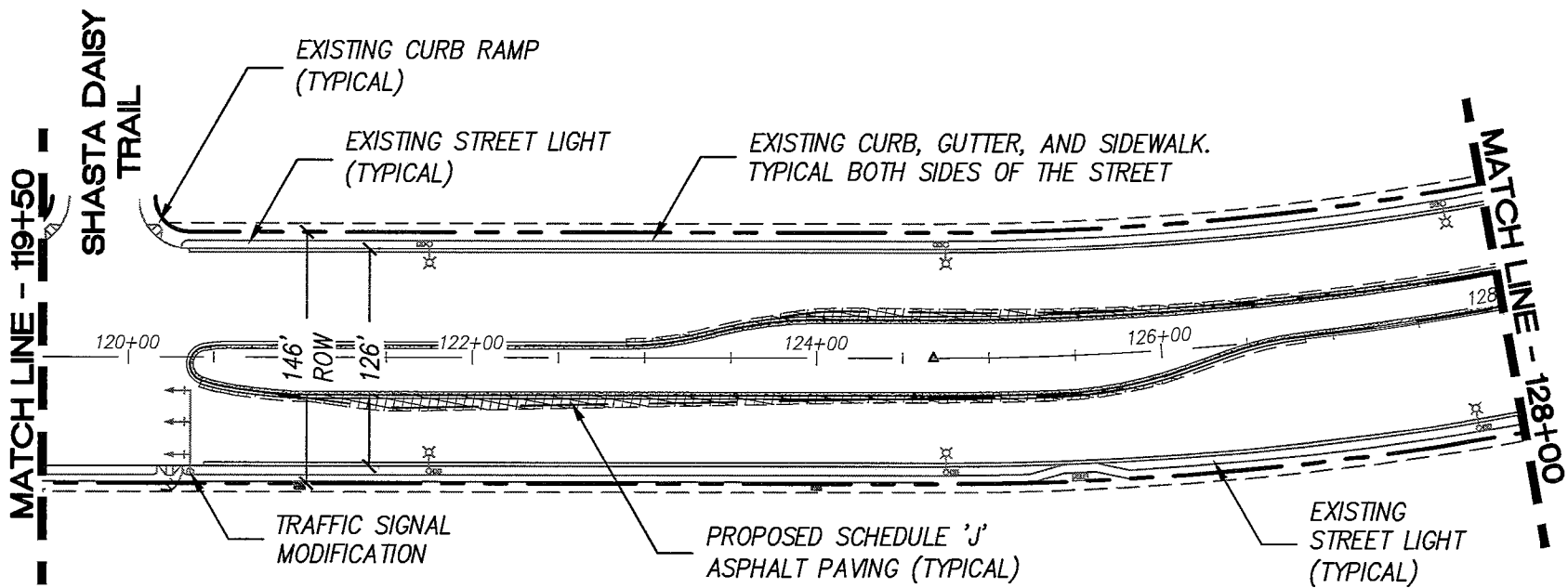

EXHIBIT 'B-3'

CARMEL VALLEY ROAD SOUTH
DRAWING NO. 38352-D

SCALE: 1"=100'	
DATE: OCT. 2, 2014	DRAWN BY: IL
JOB NO.: 633.60	CHECKED BY:

latitude 33
PLANNING & ENGINEERING
 9968 Hilbert Street 2nd Floor, San Diego, CA 92131
 Tel 858.751.0633



CARMEL VALLEY ROAD SOUTH

SCALE: 1"=100'

EXHIBIT 'B-4'

CARMEL VALLEY ROAD SOUTH
DRAWING NO. 38352-D

SCALE: 1"=100'
DATE: OCT. 2, 2014 DRAWN BY: IL
JOB NO.: 633.60 CHECKED BY:

latitude 33
PLANNING & ENGINEERING
9968 Hibert Street 2nd Floor, San Diego, CA 92131
Tel 858.751.0633

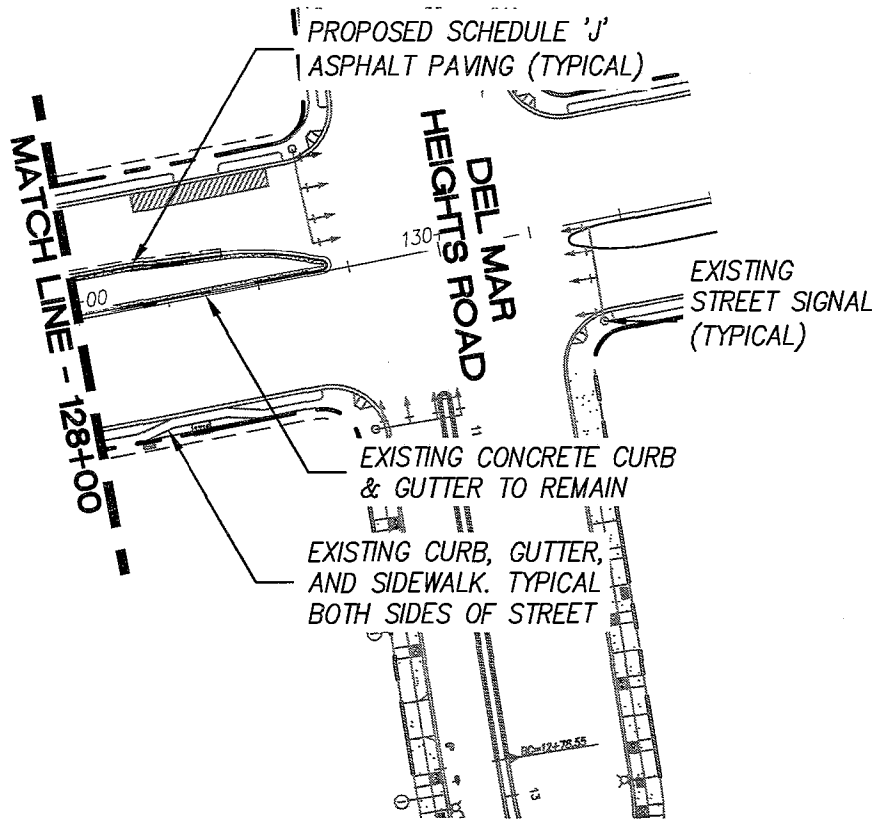

CARMEL VALLEY ROAD SOUTH

SCALE: 1"=100'

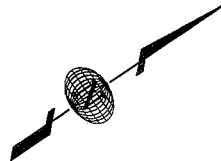
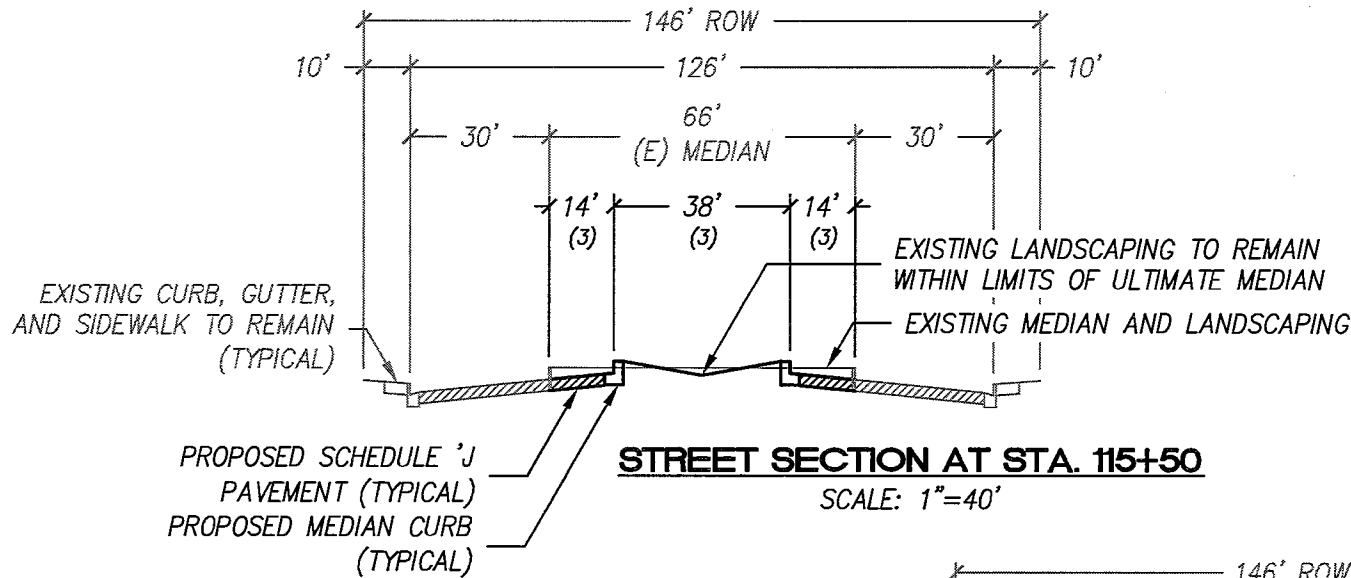

EXHIBIT 'B-5'

**CARMEL VALLEY ROAD SOUTH
DRAWING NO. 38352-D**

SCALE: 1"=100'
 DATE: OCT. 2, 2014 DRAWN BY: IL
 JOB NO.: 633.60 CHECKED BY:

latitude 33
 PLANNING & ENGINEERING
 9968 Hibert Street 2nd Floor, San Diego, CA 92131
 Tel 858.751.0633



NOTES:

1. LANDSCAPE WITHIN MEDIAN CURRENTLY MAINTAINED AND WILL CONTINUE TO BE MAINTAINED BY PACIFIC HIGHLANDS RANCH MAINTENANCE ASSESSMENT DISTRICT.
2. EXISTING IMPROVEMENTS PER CITY OF SAN DIEGO DWG. NO. 32483
3. WIDTHS SHOWN ARE FOR BONDING PURPOSES ONLY. ACTUAL WIDTHS TO BE APPROVED WITH FINAL ENGINEERING DOCUMENTS.

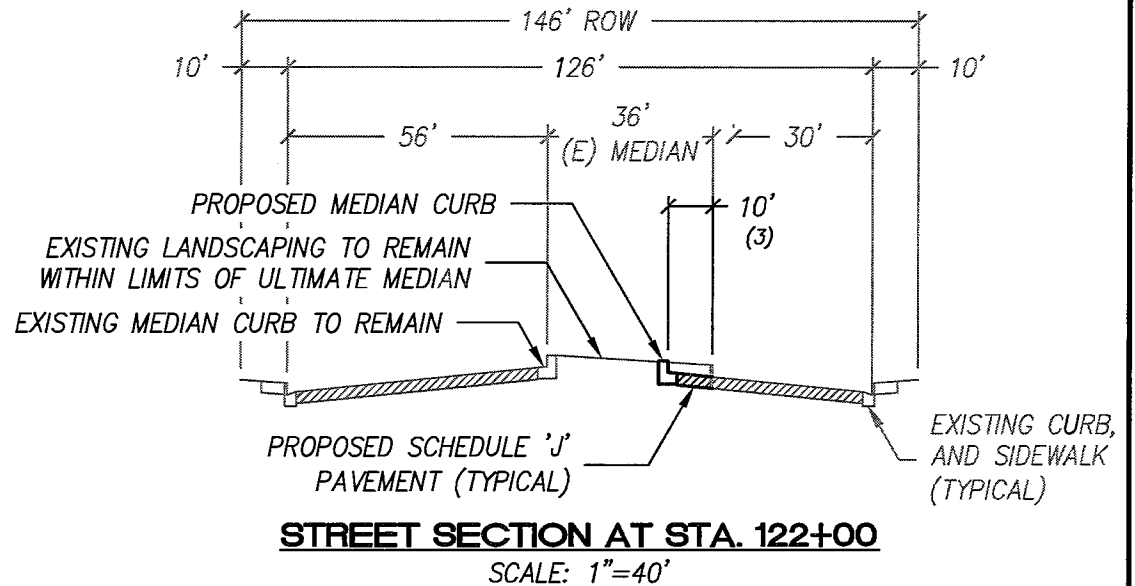

EXHIBIT 'B-6'

**CARMEL VALLEY ROAD SOUTH
DRAWING NO. 38352-D**

SCALE:	1"=100'	DRAWN BY:	IL
DATE:	OCT. 2, 2014	CHECKED BY:	
JOB NO.:	633.60		

latitude 33
PLANNING & ENGINEERING
 9968 Hibert Street 2nd Floor, San Diego, CA 92131
 Tel 858.751.0633

EXHIBIT C
Description of Project

EXHIBIT "C"

DESCRIPTION OF PROJECT

Widen Carmel Valley Road (per FBA Project No. T-4.2, Phase 2) from four lanes to six lanes within existing right-of-way from SR-56 interchange north to Del Mar Heights Road. Work includes removal of existing temporary AC berm and landscaping and construction of two additional travel lanes, median curb, gutter, and mow strip as well as traffic signal modifications, signing, and striping to six-lane arterial roadway.

Improvements shall be performed to the satisfaction of the City Engineer.

EXHIBIT D
Project Schedule

EXHIBIT “D”

PROJECT SCHEDULE

Developer shall complete the Project in accordance with the timing requirements set forth in the Deferred Improvement Agreement No. 1214151 with Pardee Homes for the Carmel Valley Road Widening from four lanes to six lanes between SR-56 and Del Mar Heights Road Project in the Pacific Highlands Ranch Community Plan Area – Project No. 346919

EXHIBIT E
Estimated Cost

EXHIBIT "E"

Estimated Cost of Project T-4.2 (5th and 6th lanes of Carmel Valley Road)

Item	Description	Amount ¹
Hard Costs		
1	Grind and Overlay (Sawcut AC x1' width)	\$22,000
2	Saw Cut Existing (AC/PCC)	\$27,000
3	Curb a Gutter Removal and Disposal Off Site (AC BERM)	\$17,000
4	AC Pavement Removal and Disposal Off Site	\$18,000
5	Landscape Removal and Disposal Off Site	\$97,000
6	Median Curb and Gutter, Per G-6 (Type B-2)	\$116,000
7	Landscape/irrigation Repairs and Maintenance	\$73,000
8	Paving Subgrade Preparation	\$19,000
9	Pavement Design, Per SDG-113 (Schedule J)	\$193,000
10	Reinstall Monument Sign	\$30,000
11	Traffic Signal Modification (3)	\$144,000
12	Remove Striping	\$26,000
13	Street Striping (more than 4000 LF)	\$15,000
14	Detector Loops	\$7,000
15	Construction Traffic Control	\$150,000
16	Mobilization	\$80,000
17	Stamped/Colored PCC	\$105,000
Subtotal Hard Costs		\$1,139,000
Soft Costs		
1	Bond Premiums	\$25,000
2	Engineering	\$100,000
3	Traffic Consultant	\$60,000
4	Survey-Staking	\$10,000
5	Soils Testing/Inspection	\$10,000
6	Landscape Architect	\$20,000
7	Public Bidding Consultant	\$25,000
8	Construction Management	\$50,000
9	Punchlist	\$10,000
10	Plan Check, Permit and Inspection Fees	\$100,000
11	As-Built	\$5,000
Subtotal Soft Costs		\$415,000
Subtotal (Hard plus Soft Costs) ²		\$1,554,000
Project Contingency (10% of Hard Costs)		<u>\$114,000</u>
Project Costs		\$1,668,000
5% Administration Fee		\$83,000
Interest (Not To Exceed \$50,000)		<u>\$50,000</u>
Estimated Cost		\$1,801,000

Note 1: All Figures are rounded to the nearest \$1,000.

Note 2: Cost savings on any line item, including a hard cost, a soft cost or contingency, but excluding administration and interest can be used to reimburse excess costs on other line items so long as the total project costs do not exceed the Maximum Funds under this Agreement.

EXHIBIT F

Project Schedule Obligations and Components

1. **Developer's Obligation.** To the extent required by City, Developer shall provide, coordinate, revise, and maintain the Project Schedule for all phases of the Project.
 - A. *Project Initiation.* During Project initiation and design phases, Developer shall submit an updated Project Schedule on a quarterly basis to City for approval.
 - B. *Construction Phase.* During Construction, Developer shall submit an updated Project Schedule monthly to City and shall include:
 - i. Forecast data with the intended plan for the remainder of the contract duration.
 - ii. Actual data with indications of when and how much work and/or services was performed (percent complete).
 - iii. Logic changes or other changes required to maintain the Project Schedule.
2. **Detail and Format.** Unless otherwise directed by City, the Project Schedule shall include all phases of the Project. It shall be in a precedence diagram format, plotted on a time-scaled calendar, detailed to activity level, and shall include:
 - A. *Identification of design and construction activities and their sequence.*
 - i. Work shall be divided into a minimum of 5 activities.
 - ii. Activities shall not exceed 21 calendar days in duration or \$50,000 in value, except long lead procurement and submittal activities or those accepted by City in writing.
 - iii. Each activity shall be assigned a budget value in accordance with Agreement requirements and activity descriptions.
 - a. The sum of all budget values assigned shall equal Estimated Cost.
 - b. Each construction activity shall indicate the estimated labor days and materials quantities required.
 - iv. Incorporate specific activity and time requirements.
 - v. Include 10 weather/delay days, commonly known as "rain days." The late finish date shall be the fully elapsed Contract Time.
 - B. *Float Time.* Show activities on their early dates with corresponding Total Float Time noted beside them.
 - i. Project Schedule shall not include more than 40 calendar days of Float Time absent written City approval.
 - C. *Milestones.* Show milestones with beginning and ending dates.
 - i. Milestones shall include schematic plans, 60% design, 90% design, 100% design; bid opening; Notice to Proceed; start construction; end construction; and Project Completion and Acceptance.
 - D. *Relationships.* Show all appropriate definable relationships with separate explanation of constraints and each start-start, finish-finish, or lag relationship. Relate all activities to each other and to the first appropriate milestone.
 - E. *Procurement.* Show the procurement of major equipment and materials.
 - F. *Submittals.* Include all submittals required and identify the planned submittal dates, adequate review time, and the dates acceptance is required to support design and construction.
3. **Submittal.** The Project Schedule shall be submitted to City on a computer disk in PRIMAVERA Project Planner P3e/c Release Version 4.1 SP1 software in conformance with Construction Plans & Scheduling by AGC or America, or other software specifically designated by City.

EXHIBIT G

Meeting Requirements

1. **Preconstruction Meeting.** Developer shall conduct a preconstruction meeting with its officers, agents, and employees and City. The purpose of this meeting is to discuss: (1) the Agreement conditions, (2) Scope of Work clarifications, and (3) City policies, inspection requirements, and procedures.
 - A. *Attendance.* Developer shall ensure that its construction contractor and major subcontractors, the Project Superintendent, and the City Inspection Team as set forth in the Agreement, and all other persons necessary as determined by Developer or City attend the preconstruction meeting.
 - B. *Minutes.* Developer shall take corresponding meeting minutes and distribute copies to all attendees.
2. **Progress Meetings.** Developer shall conduct weekly progress meetings at dates and times scheduled at the preconstruction meeting with the following necessary parties: Developer's Construction Superintendent, Developer's Project Manager, Developer's Design Consultant, City representatives including Responsible Department representatives, the Engineering and Capital Projects Project Manager and the Resident Engineer.
 - A. *As-Builts.* Developer shall bring updated As-Builts and verify that the latest changes have been made.
 - B. *Special Meetings.* Special meetings shall occur at Project phases as outlined in **Exhibit H**.
 - C. *Rescheduling.* Progress and Special Meetings may be rescheduled if rescheduled meeting times are convenient for all necessary parties, and Developer has given no less than seven calendar days prior written notice of the rescheduled meeting.
3. **Agenda.** All meetings shall include at a minimum the agenda identified in **Exhibit H**.

EXHIBIT H

Preconstruction, Progress, & Special Meeting Agenda

1. Preconstruction. The issues below should be made part of the Preconstruction Meeting Agenda, provided however that the agenda may deviate depending on the circumstances that exist at that time.
 - 1.1 Permits and utility issues, including telephone, cable, gas, and electric. RE to announce to Developer that franchise companies may be working in the area of the Project and that coordination regarding such a situation may need to be done.
 - 1.2 Establish parking areas for construction employees and possibly patrons/others.
 - 1.3 Developer's payment procedure and forms.
 - 1.4 Format for Request for Proposals (RFPs) using the sample in the back of the contract documents.
 - 1.5 Collection of emergency numbers for off-hour emergencies from the prime (with an alternate contact person).
 - 1.6 Distribution and discussion of the construction schedule.
 - 1.7 Procedure for maintaining the Project record documents.
 - 1.8 Distribution of the Second Opinion Option Form.
 - 1.9 Designation of persons authorized to represent and sign documents for the RE and Developer and the respective communication procedures between parties.
 - 1.10 Safety and first aid procedures including designation of Developer's safety officer.
 - 1.11 Temporary barricades, fencing, signs, and entrance and exit designations, etc.
 - 1.12 Testing laboratory or agency and testing procedures.
 - 1.13 Establish schedule for progress meetings.
 - 1.14 Procedure for changes in work requested by Developer, notice to RE, timing, etc.
 - 1.15 Procedure for changes in work requested by City.
 - 1.16 Public safety.
 - 1.17 Housekeeping procedures and Project site maintenance.
 - 1.18 Protection and restoration of existing improvements.
 - 1.19 Sanitation, temporary lighting, power, water, etc.
 - 1.20 Procedure for encountering hazardous substances.
 - 1.21 Any items requested by attendees of preconstruction meeting/open discussion.
2. Progress Meetings. The issues below should be made part of the Progress Meeting Agenda, provided however that the agenda may deviate depending on the circumstances that exist at that time.
 - 2.1 Review progress of construction since the previous meeting.
 - 2.2 Discuss field observations, problems, conflicts, opportunities, etc.
 - 2.3 Discuss pre-planning opportunities.
 - 2.4 Identify problems that impede planned progress and develop corrective measures as required to regain the projected schedule; revise the schedule if necessary.
 - 2.5 Discuss Developer's plan for progress during the next construction period and the corresponding inspections necessary.

- 2.6 Discuss submittal status.
 - 2.7 Discuss request for information (RFI) status.
 - 2.8 Progress of schedule.
 - 2.9 Disputed items.
 - 2.10 Non-conformance/non-compliance items.
 - 2.11 New business of importance from any member of the meeting.
 - 2.12 Deferred approvals and their coordination.
 - 2.13 Discuss request for proposals, change orders, and progress payment status.
3. Special Meetings.
- 3.1 Grading. Prior to grading the site, the RE shall call a grading mini-preconstruction meeting. This meeting applies when surveying is being supplied by the City. The superintendent, the Developer's appropriate subcontractors, the RE, the City's survey crew, and any appropriate consultants (if deemed necessary by the RE) shall attend. Unless otherwise noted, the agenda will be to coordinate the staking, reference markers, bearings, various site conditions, etc. as defined in the contract documents and any necessary coordination of scope or scheduling between the respective parties.
 - 3.2 Roofing. Upon completion of the roofing structural diaphragm and prior to installing flashing, and/or any other roofing materials, the RE shall call a roof mini-preconstruction meeting. The superintendent, the Developer's appropriate contractors, the RE, any City representative deemed appropriate by the RE, the roof suppliers manufacturer's representative, and any appropriate consultants (if deemed necessary by the RE) shall attend. The agenda will be to coordinate the flashing, caulking, sealing, and different roofing materials and/or contractors on site with the various field conditions.
 - 3.3 Landscaping. Upon completion of the grading and prior to the installation of any landscaping equipment, supplies, etc., the RE shall call a landscaping mini-preconstruction meeting. The superintendent, the Developer's appropriate contractors, the RE, any City representative deemed appropriate by the RE, and any appropriate consultants (if deemed necessary by the RE) shall attend. The agenda will be to coordinate all landscape materials, plant and irrigation coverage, visual planting procedures, etc. and/or contractors on site with the various field conditions.
 - 3.4 Mini-Preconstruction Meeting. Prior to the installation of any mechanical, electrical, plumbing, and sprinkler system equipment, the Developer shall call a mini-preconstruction meeting. The superintendent, the Developer's appropriate contractors, the RE, any City representative deemed appropriate by the RE, and any appropriate consultants (if deemed necessary by the RE) shall attend. The intent of this meeting is to ensure that the prime contractor is adequately coordinating the space of the facility so as to not impede the visual integrity of the overall product.
 - 3.5 Other. Upon appropriate notice to other parties, the RE may call special meetings at times agreed to by all parties involved.

EXHIBIT I

Procedure for Processing Change Orders

1. **Forms Required.** All Change Orders shall be in writing on the appropriate City form and must be approved or rejected by City in writing as provided in Section 3, below, and delivered to Developer.
2. **Written Approval of Change Orders.** Change Orders that will not result in an increase in the Estimated Cost may be approved by the RE. If a requested Change Order would result in an increase in the Estimated Cost, approval of the Change Order shall require City Council approval.
3. **Process for Approval of Change Orders.** Developer shall notify the RE in writing of the need for a Change Order. A Change Order must indicate whether the change will result in any change to the Estimated Cost, Project Schedule, or Project quality established during the design and submittal review process.
 - 3.1 ***Resident Engineer Approval.*** If the Change Order request does not result in an increase in the Estimated Cost, the RE shall either approve or reject the Change Order in writing within fourteen (14) calendar days of receiving Developer's written notice, provided Developer has submitted complete documentation substantiating the need for such Change Order. If City fails to respond to Developer's written notice within the fourteen (14) calendar days, the Change Order request shall automatically be deemed denied.
 - 3.2 ***City Council Approval.*** For Change Orders not subject to Section 3.1 above, City Council approval is required. In such cases, once a Change Order is preliminarily accepted by the appropriate City staff, City staff shall process the Change Order along with any required amendments to the Financing Plan and this Agreement as a 1472 (Request for Council Action). At a hearing on such Request for Council Action, City Council may either approve or reject such Change Orders. Council Approval shall not be subject to the fourteen (14) calendar day response time set forth above in Section 3.1. Furthermore, nothing in this Agreement shall compel the City Council to take any particular action.

Exhibit J

Equal Benefits Ordinance Certification of Compliance

**EQUAL BENEFITS ORDINANCE
CERTIFICATION OF COMPLIANCE**



For additional information, contact:
CITY OF SAN DIEGO
EQUAL BENEFITS PROGRAM
 202 C Street, MS 9A, San Diego, CA 92101
 Phone (619) 533-3948 Fax (619) 533-3220

COMPANY INFORMATION		
Company Name:	Contact Name:	
Company Address:	Contact Phone:	
Contact Email:		
CONTRACT INFORMATION		
Contract Title:	Start Date:	
Contract Number (if no number, state location):	End Date:	
SUMMARY OF EQUAL BENEFITS ORDINANCE REQUIREMENTS		
<p>The Equal Benefits Ordinance [EBO] requires the City to enter into contracts only with contractors who certify they will provide and maintain equal benefits as defined in San Diego Municipal Code §22.4302 for the duration of the contract. To comply:</p> <ul style="list-style-type: none"> ■ Contractor shall offer equal benefits to employees with spouses and employees with domestic partners. <ul style="list-style-type: none"> ▪ Benefits include health, dental, vision insurance; pension/401(k) plans; bereavement, family, parental leave; discounts, child care; travel/relocation expenses; employee assistance programs; credit union membership; or any other benefit. ▪ Any benefit not offered to an employee with a spouse, is not required to be offered to an employee with a domestic partner. ■ Contractor shall post notice of firm's equal benefits policy in the workplace and notify employees at time of hire and during open enrollment periods. ■ Contractor shall allow City access to records, when requested, to confirm compliance with EBO requirements. ■ Contractor shall submit <i>EBO Certification of Compliance</i>, signed under penalty of perjury, prior to award of contract. <p>NOTE: This summary is provided for convenience. Full text of the EBO and its Rules are posted at www.sandiego.gov/administration.</p>		
CONTRACTOR EQUAL BENEFITS ORDINANCE CERTIFICATION		
<p>Please indicate your firm's compliance status with the EBO. The City may request supporting documentation.</p> <p><input type="checkbox"/> I affirm compliance with the EBO because my firm (<i>contractor must select one reason</i>):</p> <ul style="list-style-type: none"> <input type="checkbox"/> Provides equal benefits to spouses and domestic partners. <input type="checkbox"/> Provides no benefits to spouses or domestic partners. <input type="checkbox"/> Has no employees. <input type="checkbox"/> Has collective bargaining agreement(s) in place prior to January 1, 2011, that has not been renewed or expired. <p><input type="checkbox"/> I request the City's approval to pay affected employees a cash equivalent in lieu of equal benefits and verify my firm made a reasonable effort but is not able to provide equal benefits upon contract award. I agree to notify employees of the availability of a cash equivalent for benefits available to spouses but not domestic partners and to continue to make every reasonable effort to extend all available benefits to domestic partners.</p> <p>It is unlawful for any contractor to knowingly submit any false information to the City regarding equal benefits or cash equivalent associated with the execution, award, amendment, or administration of any contract. [San Diego Municipal Code §22.4307(a)]</p> <p>Under penalty of perjury under laws of the State of California, I certify the above information is true and correct. I further certify that my firm understands the requirements of the Equal Benefits Ordinance and will provide and maintain equal benefits for the duration of the contract or pay a cash equivalent if authorized by the City.</p>		
Name/Title of Signatory	Signature	Date
FOR OFFICIAL CITY USE ONLY		
Receipt Date:	EBO Analyst:	<input type="checkbox"/> Approved <input type="checkbox"/> Not Approved -- Reason:

rev 02/15/2011

EXHIBIT K

Consultant Provisions

1. **Third Party Beneficiary.** The City of San Diego is an intended third party beneficiary of this contract. In addition, it is expected that upon completion of design and payment in full to Consultant by Developer, the City will become the owner of the Project design and work products, and City shall be entitled to enforce all of the provisions of this contract as if it were a party hereto. Except as expressly stated herein, there are no other intended third party beneficiaries of this contract.
2. **Competitive Bidding.** Consultant shall ensure that all design plans and specifications prepared, required, or recommended under this Agreement allow for competitive bidding. Consultant shall design such plans or specifications so that procurement of services, labor or materials are not available from only one source, and shall not design plans and specifications around a single or specific product, piece of major equipment or machinery, a specific patented design, or a proprietary process, unless required by principles of sound engineering practice and supported by a written justification that has been approved in writing by the City of San Diego. Consultant shall submit this written justification to the City of San Diego prior to beginning work on such plans or specifications. Whenever Consultant recommends a specific product or equipment for competitive procurement, such recommendation shall include at least two brand names of products that are capable of meeting the functional requirements applicable to the Project.
3. **Professional Services Indemnification.** Other than in the performance of design professional services which shall be solely as addressed in Sections 4 and 5 below, to the fullest extent permitted by law, Consultant shall defend (with legal counsel reasonably acceptable to the City), indemnify and hold harmless the City and its officers, agents, departments, officials, and employees (Indemnified Parties) from and against all claims, losses, costs, damages, injuries (including, without limitation, injury to or death of an employee of Consultant or its subcontractors, agents, subagents and consultants), expense and liability of every kind, nature and description (including, without limitation, incidental and consequential damages, court costs, attorney's fees, litigation expenses and fees of expert consultants or expert witnesses incurred in connection therewith and costs of investigation) that arise out of, pertain to, or relate to, directly or indirectly, in whole or in part, any services performed under this Agreement by Consultant, any subcontractor, anyone directly or indirectly employed by them, or anyone they control. Consultant's duty to defend, indemnify, protect and hold harmless shall not include any claims or liabilities arising from the active negligence, sole negligence or willful misconduct of the Indemnified Parties. As to Consultant's professional obligations, work or services involving this Project, Consultant agrees to indemnify and hold harmless the City of San Diego, and its agents, officers and employees from and against any and all liability, claims, costs, and damages, including but not limited to, attorney's fees, losses or payments for injury to any person or property, caused directly or indirectly from the negligent acts, errors or omissions of Consultant or Consultant's employees, agents or officers. This indemnity obligation shall apply for the entire time that any third party can make a claim against, or sue the City of San Diego for liabilities arising out of Consultant's provision of services under this Agreement.
4. **Indemnification for Design Professional Services.** To the fullest extent permitted by law (including, without limitation, California Civil Code section 2782.8), with respect to the performance of design professional services, Design Professional shall indemnify and hold harmless the City, its officers, and/or employees, from all claims, demands or liability that arise out of, pertain to or relate to the negligence, recklessness, or willful misconduct of Design Professional or Design Professional's officers or employees.
5. **Design Professional Services Defense.** Parties will work in good faith to procure applicable insurance coverage for the cost of any defense arising from all claims, demands or liability that arise out of, pertain to or relate to the negligence, recklessness, or willful misconduct of Design Professional or Design Professional's officers or employees.
6. **Enforcement Costs.** Consultant agrees to pay any and all reasonable costs the City of San Diego may incur to enforce the indemnity and defense provisions set forth in this Agreement.
7. **Professional Liability Insurance.** For all of Consultant's employees who are subject to this Agreement, Consultant shall keep in full force and effect, errors and omissions insurance providing coverage for professional liability with a combined single limit of one million dollars (\$1,000,000) per claim and two million dollars (\$2,000,000) aggregate. Consultant shall ensure both that (1) this policy's retroactive date is on or before

the date of commencement of the work to be performed under this Agreement; and (2) this policy has a reporting period of three (3) years after the date of completion or termination of this Agreement. Consultant agrees that for the time period defined above, there will be no changes or endorsements to the policy that increases the City of San Diego's exposure to loss.

8. **Commercial General Liability (CGL) Insurance.** Consultant shall keep in full force and effect, during any and all work performed in accordance with this Agreement, all applicable CGL insurance to cover personal injury, bodily injury and property damage, providing coverage to a combined single limit of one million dollars (\$1,000,000) per occurrence, subject to an annual aggregate of two million dollars (\$2,000,000) for general liability, completed operations, and personal injury other than bodily injury. Contractual liability shall include coverage of tort liability of another party to pay for bodily injury or property damage to a third person or organization. Contractual liability limitation endorsement is not acceptable.
9. **Insurance Policy Requirements.** Except for professional liability insurance and Workers Compensation, the City of San Diego and its respective elected officials, officers, employees, agents, and representatives shall be named as additional insureds. Additional insured status must be reflected on additional insured endorsement form CG 20 10, or equivalent, which shall be submitted to the City of San Diego. Further, all insurance required by express provision of this agreement shall be carried only by responsible insurance companies that have been given at least an "A" or "A-" and "VII" rating by AM BEST, that are licensed to do business in the State of California, and that have been approved by the City of San Diego. The policies cannot be canceled, non-renewed, or materially changed except after thirty (30) calendar days prior written notice by Consultant or Consultant's insurer to the City of San Diego by certified mail, as reflected on an endorsement that shall be submitted to the City of San Diego, except for non-payment of premium, in which case ten (10) calendar days notice must be provided. Before performing any work in accordance with this Agreement, Consultant shall provide the City of San Diego with all Certificates of Insurance accompanied with all endorsements.
10. **Workers Compensation.** For all of the Consultant's employees who are subject to this Agreement and to the extent required by the State of California, the Consultant shall keep in full force and effect, a Workers Compensation policy. That policy shall provide a minimum of one million dollars (\$1,000,000) of employers liability coverage, and the Consultant shall provide an endorsement that the insurer waives the right of subrogation against the City of San Diego and its respective elected officials, officers, employees, agents and representatives.
11. **Compliance Provision.** Consultant agrees, at its sole cost and expense, to perform all design, contract administration, and other services in accordance with all applicable laws, regulations, and codes, including, but not limited to, the Americans with Disabilities Act of 1990 (ADA) and title 24 of the California Code of Regulations as defined in Section 18910 of the California Health and Safety Code (Title 24). Further, Consultant is responsible as designer and employer to comply with all parts of the ADA and Title 24.
12. **Maintenance of Records.** Consultant shall maintain books, records, logs, documents and other evidence sufficient to record all actions taken with respect to the rendering of services for the Project, throughout the performance of the services and for a period of five (5) years following completion of the services for the Project. Consultant further agrees to allow the City of San Diego to inspect, copy and audit such books, records, documents and other evidence upon reasonable written notice. In addition, Consultant agrees to provide the City of San Diego with complete copies of final Project design and construction plans and Project cost estimate.

EXHIBIT L

Design and Construction Standards

1. **Laws.** Developer shall comply with all local, City, County, State, and Federal laws, codes and regulations, ordinances, and policies, including, but not limited to, the following:
 - A. *Permits.* Development Services Department permits, hazardous material permits, Coastal Commission permits.
 - B. *Building Codes.* State and local Building Codes
 - C. *The Americans with Disabilities Act (ADA) and Title 24 of the California Building Code (Title 24).* It is Developer's sole responsibility to comply with all ADA and Title 24 regulations. See Developer Certification attached as **Exhibit M**.
 - D. *Environmental.* Developer shall complete all environmental measures required by the California Environmental Quality Act (CEQA), the National Environmental Policy Act (NEPA), and the local jurisdiction, including but not limited to, implementation of mitigation measures, and conducting site monitoring.
 - E. *Air, Water, and Discharge.* Developer shall comply with the Clean Air Act of 1970, the Clean Water Act, and San Diego Municipal Code Chapter 4, Article 3, Division 3 (Stormwater Management and Discharge Control).
 - F. *ESBSSA.* Developer shall comply with the Essential Services Building Seismic Safety Act, SB 239 & 132.
 - G. *City Directives.* Developer shall comply immediately with all directives issued by City or its authorized representatives under authority of any laws, statutes, ordinances, rules, or regulations.
2. **Standard Specifications.** Developer shall comply with the most current editions of the following reference specifications when designing and constructing the Project, including:
 - A. *Green Book.* Standard Specifications for Public Works Construction, including the Regional and City of San Diego Supplement Amendments.
 - B. *DOT.* California Department of Transportation Manual of Traffic Controls for Construction and Maintenance Work Zones.
3. **City Standards.** Developer's professional services shall be provided in conformance with the professional standards of practice established by City. This includes all amendments and revisions of these standards as adopted by City. The professional standards of practice established by City include, but are not limited to, the following:
 - A. *City of San Diego's Drainage Design Manual*
 - B. *City of San Diego's Landscape Technical Manual*
 - C. *City of San Diego's Street Design Manual*
 - D. *City of San Diego's Manual of Preparation of Land Development and Public Improvement Plans*
 - E. *City of San Diego's Technical Guidelines for Geotechnical Reports*
 - F. *City of San Diego Standard Drawings including all Regional Standard Drawings*
 - G. *City of San Diego Data Standards for Improvement Plans*
 - H. *The City of San Diego Consultant's Guide to Park Design and Development.*
 - I. *The City of San Diego Water Department Guidelines and Standards*

EXHIBIT M

Certification for Title 24/ADA Compliance

Project No. T-4.2, CARMEL VALLEY ROAD (4/6 LANES SOUTH OF DEL MAR HEIGHTS ROAD-
PHASE II)

I HEREBY WARRANT AND CERTIFY that any and all plans and specifications prepared for CARMEL VALLEY ROAD (4/6 LANES SOUTH OF DEL MAR HEIGHTS ROAD-PHASE II) by LATITUDE 33 shall meet all current California Building Standards Code, California Code of Regulations, Title 24 and Americans with Disabilities Act Accessibility Guidelines requirements, and shall be in compliance with the Americans with Disabilities Act of 1990.



Dated: 5/28/15

By: *John Eardens*

EXHIBIT N

Approval of Design, Plans, and Specifications

UNLESS OTHERWISE DIRECTED BY THE CITY IN WRITING, DEVELOPER SHALL OBTAIN APPROVAL OF DESIGN, PLANS, AND SPECIFICATIONS IN THE MANNER IDENTIFIED BELOW:

1. **City Approval.** Developer shall obtain City approval of the design, in writing, at schematic design, 60% Design, and 90% Design.
 - A. *Condition Precedent.* City approval of the Schematic Design Documents is a condition precedent to authorization to proceed with subsequent work on the Project. City will notify Developer in writing within four weeks after receipt of Design Documents of approval, or of request for modifications. If modifications are requested, Developer shall modify and resubmit Schematics for City approval.
 - B. *Sixty (60) Percent Design.* At 60% design, City will notify Developer in writing within eight weeks after receipt of Design Documents at each required stage of design, of approval, or of request for modifications. If modifications are requested, Developer shall modify and resubmit Design Documents for City approval.
 - C. *Ninety (90) Percent Design.* At 90% design, City will notify Developer in writing within ten weeks after receipt of design documents at each required stage of design, of approval, or of request for modifications. If modifications are requested, Developer shall modify and resubmit Design Documents for City approval.
2. **Submittal of Plans, Specifications, and Budget.** Within six (6) months of City Council approval of this Agreement, Developer shall deliver to City complete Plans and Specifications, Estimated Costs, and bid documents, consistent with the Schematic Drawings, for the design and construction of the Project.
3. **Citywide Review of 100% Plans and Specifications.** City agrees to review the Plans and Specifications and provide City's written comments to Developer within ninety (90) calendar days of the date such Plans and Specifications are delivered to City in accordance with the notice provisions in Article XXIV. Plans and Specifications shall include City's standard drawings and specifications as described in **Exhibit L**. If requested by City, Developer shall make changes to the Plans and Specifications, but Developer shall not be responsible for implementing such changes if they would increase the Estimated Cost by more than 5%. In such a case, the changes to the Plans and Specifications shall be considered additive or deductive bid alternates to the Project.
4. **Final Approval and Permit Review.** City approval of the Plans and Specifications is a condition precedent to authorization to proceed with subsequent work on the Project. Approval and permit review will require a minimum of ninety (90) calendar days from the date that the Plans and Specifications were submitted to the City review, if no changes are required, or ninety (90) days from the date the requested changes are submitted to the City.

EXHIBIT O

Construction Obligations

1. **Site Safety, Security, and Compliance.** Developer shall be responsible for site safety, security, and compliance with all related laws and regulations.
 - A. *Persons.* Developer shall be fully responsible for the safety and security of its officers, agents, and employees, City's officers, agents, and employees, and third parties authorized by Developer to access the Project site.
 - B. *Other.* Developer is responsible for the Project, site, materials, equipment, and all other incidentals until the Project has been accepted by the City pursuant to Article I.
 - C. *Environment.* Developer shall be responsible for the environmental consequences of the Project construction and shall comply with all related laws and regulations, including, but not limited to, the Clean Air Act of 1970, the Clean Water Act, Executive Order Number 11738, and the Stormwater Management and Discharge Control Ordinance No. 0-17988, and any and all Best Management Practice guidelines and pollution elimination requirements as may be established by the Enforcement Official. Furthermore, the Developer shall prepare and incorporate into the Construction Documents a Stormwater Pollution Prevention Plan (SWPPP) to be implemented by the Developer during Project construction. Where applicable, the SWPPP shall comply with both the California Regional Water Quality Control Board Statewide General Construction Storm Water permit and National Pollution Discharge Elimination System permit requirements and any municipal regulations adopted pursuant to the permits.
2. **Access to Project Site.**
 - A. *Field Office.* Developer shall provide in the construction budget a City field office (approximately 100 square feet) that allows City access to a desk, chair, two drawer locking file cabinet with key, phone, fax, computer, copy machine and paper during working hours.
 - B. *Site Access.* City officers, agents and employees have the right to enter the Project site at any time; however, City will endeavor to coordinate any entry with Developer.
 - C. *Site Tours.* Site tours may be necessary throughout completion of the Project. Developer shall allow City to conduct site tours from time to time as the City deems necessary. City will give Developer notice of a prospective tour and a mutually agreeable time shall be set. Developer is not obligated to conduct tours or allow access for tours when City fails to give prior notice.
3. **Surveying and Testing.** Developer shall coordinate, perform, and complete all surveying, materials testing, and special testing for the Project at the Project site, as otherwise required by this Agreement, and as required under the State Building Code or any other law or regulation, including:
 - A. *Existing Conditions.* Developer shall obtain all necessary soils investigation and conduct agronomic testing required for design of the Project. The soils consultant shall prepare a statement that will be included in the Bidding Documents as to the nature of soils, ground water conditions and any other information concerning the existing conditions of the site.
 - B. *Utilities.* Developer shall provide all required information for the construction or relocation of public or private utility facilities that must be constructed or relocated as a result of this Project. Developer shall file all of the required documents for the approval of authorities having jurisdiction over the Project and in obtaining the services of all utilities required by the Project.
 - C. *Geotechnical Information.* Developer shall obtain all necessary geotechnical information required for the design and construction of the Project. The Project Engineering Geologist and/or Project Soils Engineer (qualified R.C.E. or R.G.E.) shall prepare a statement, that will be included in the Bidding Documents, to address existing geotechnical conditions of the site that might affect construction.

4. **Public Right of Way.** All work, including, materials testing, special testing, and surveying to be conducted in the public right-of-way shall be coordinated with the City.
 - A. *Materials Testing.* Developer shall pay for and coordinate with City to have all material tests within the public right-of-way and any asphalt paving completed by City's Material Testing Laboratory.
 - B. *Surveying.* Developer shall pay for and coordinate with City's Survey Section all surveying required within the public right-of-way.
 - C. *Follow all Laws, Rules, and Regulations.* Developer agrees to follow all City standards and regulations while working in the public right-of-way, including but not limited to, utilizing proper traffic control and obtaining necessary permits.
5. **Traffic Control.** Developer shall address all traffic control requirements for the Project including, if necessary, separate traffic control plans, and/or notes.
6. **Inspections.** Developer shall coordinate any and all special inspections required for compliance with all State Building Codes as specified in the Contract Documents.
 - A. *Reports.* Developer shall provide City all special inspection reports within seven (7) calendar days of inspection. Developer shall report all failures of special inspections to City.
 - B. *Remedies.* Remedies for compliance shall be approved by Developer, Developer's consultants, City's Development Services Department, and City representatives.
 - C. *Concealing Work.* Prior to concealing work, Developer shall obtain approval of the work from the following three entities: 1) Engineering & Capital Projects Department; 2) Development Services Department; and 3) Special Inspections - as required by all State Building Codes and as provided in this Agreement. This approval is general approval only and in no way relieves Developer of its sole responsibilities under this Agreement or any and all laws, codes, permits or regulations. Developer shall fulfill all requirements of each of these three entities.
7. **Property Rights.** Developer shall provide all required easement documents, including but not limited to: dedication, acquisitions, set asides, street vacations, abandonments, subordination agreements, and joint use agreements, as required by City of San Diego Real Estate Assets Department requirements. City shall not require Developer to provide any easement documents for land to which Developer does not have title; however, Developer shall not relinquish, sell or transfer title to avoid any obligation under this Section, this Agreement, the Public Facilities Financing Plans or any applicable Development Agreement or other entitlement.
8. **Permits.** The Parties acknowledge the construction work to be performed on the Project by Developer in compliance with this Agreement is subject to the prior issuance of building, land development, and/or public improvement permits paid for and obtained by Developer. In the event that City, or any other governmental agency, unreasonably refuses to issue the permit(s) necessary to authorize the work to be performed or if the permit(s) are unreasonably canceled or suspended, then Developer is relieved from its obligation to construct those improvements covered by the denial of said permit(s), and City shall reimburse Developer in accordance with the terms of the Agreement for the work completed. All plans, specifications and improvements completed to the date of the denial, suspension or cancellation of said permit(s) shall become the property of City upon reimbursement as set forth above.
9. **Maintenance.** Developer shall maintain and be responsible for the Project site until Acceptance of the Project, including ongoing erosion prevention measures. Unless stated otherwise in the Agreement, upon Acceptance of the Project, City shall be responsible for all maintenance of Project site.
10. **Drug-Free Workplace.** Developer agrees to comply with the City's requirements in Council Policy 100-17, "DRUG-FREE WORKPLACE," adopted by San Diego Resolution R-277952 and incorporated into this Agreement by this reference. Developer shall certify to the City that it will provide a drug-free workplace by submitting a Developer Certification for a Drug-Free Workplace form (**Exhibit P**).
 - A. *Developer Notice to Employees.* Developer shall publish a statement notifying employees that the unlawful manufacture, distribution, dispensation, possession, or use of a controlled substance is

prohibited in the work place, and specifying the actions that will be taken against employees for violations of the prohibition.

B. *Drug-Free Awareness Program.* Developer shall establish a drug-free awareness program to inform employees about all of the following:

- i. The dangers of drug abuse in the work place.
- ii. The policy of maintaining a drug free work place.
- iii. Available drug counseling, rehabilitation, and employee assistance programs.
- iv. The penalties that may be imposed upon employees for drug abuse violations.
- v. In addition to Section 10.A above, the Developer shall post the drug-free policy in a prominent place.

C. *Developer's Agreements.* Developer further certifies that each contract for consultant or contractor services for this Project shall contain language that binds the consultant or contractor to comply with the provisions of Section 10 "Drug-Free Workplace," as required by Sections 2.A(1) through (3) of Council Policy 100-17. Consultants and contractors shall be individually responsible for their own drug-free work place program.

EXHIBIT P

Certification for a Drug-Free Workplace

PROJECT TITLE: Project No. T-4.2, CARMEL VALLEY ROAD (4/6 LANES SOUTH OF DEL
MAR HEIGHTS ROAD-PHASE II)

I hereby certify that I am familiar with the requirement of San Diego City Council Policy No. 100-17 regarding Drug-Free Workplace, and that PARDEE HOMES has in place a drug-free workplace program that complies with said policy. I further certify that each subcontract agreement for this Project contains language that indicates the Subconsultants/Subcontractors agreement to abide by the provisions of Sections 2.A(1) through (3) of Council Policy 100-17 as outlined.

Signed 
Printed Name Sarah Reeve
Title HR Manager
Date 8-3-2015

EXHIBIT Q

Product Submittal and Substitution

1. **Product Submittal.** Prior to the bidding process, Developer shall submit for City approval a list of products intended for use in the Project. Upon Developer's completion of Plans and Specifications, City will review and approve products specified therein. Developer shall provide City a copy of each submittal for City approval throughout the duration of construction within twenty (20) Calendar Days of Developer's receipt of submittal. Approval is general approval only and in no way relieves Developer of its sole responsibilities under this Agreement or any and all laws, codes, permits, or regulations.
2. **Substitutions.** Developer shall submit all requests for product substitutions to City in writing within thirty (30) Calendar Days after the date of award of the construction contract. After expiration of the thirty (30) calendar days, City will allow substitution only when a product becomes unavailable due to no fault of Developer's contractor. City shall review substitution requests within thirty (30) Calendar Days of submission of such requests. Developer agrees that City requires Consultant's input and as such Developer shall coordinate a seven (7) calendar review by its Consultant.
 - A. *Substantiate Request.* Developer shall include with each substitution request complete data that substantiates that the proposed substitution conforms to requirements of the Contract Documents.
 - B. *Developer Representations.* By submitting a substitution request, Developer is representing to City all of the following: (a) Developer has investigated proposed product and determined that in all respect the proposed product meets or exceeds the specified product; (b) Developer is providing the same warranty for the proposed product as was available for the specified product; (c) Developer shall coordinate installation and make any other necessary modifications that may be required for work to be complete in all respects; and (d) Developer shall waive any claims for additional costs related to the substituted product, unless the specified product is not commercially available.
 - C. *Separate Written Request.* City will not consider either substitutions that are implied in the product data submittal without a separate written request or substitutions that will require substantial revision of construction contract documents.
3. **Samples.**
 - A. *Postage.* Samples shall be sent to Developer's office, postage prepaid.
 - B. *Review.* Developer shall furnish to City for review, prior to purchasing, fabricating, applying or installing, two (2) samples (other than field samples) of each required material with the required finish.
 - i. Where applicable, all samples shall be 8" x 10" in size and shall be limited in thickness to a minimum consistent with sample analysis. In lieu thereof, the actual full-size item shall be submitted.
 - ii. Developer shall assign a submittal number. Developer shall include with each submission a list of all samples sent, a statement as to the usage of each sample and its location in the Project, the name of the manufacturer, trade name, style, model, and any other necessary identifying information.
 - iii. All materials, finishes, and workmanship in the complete building shall be equal in every respect to that of the reviewed sample.
 - iv. City will return one submitted sample upon completion of City review.
 - v. Developer's or Developer's agents' field samples shall be prepared at the site. Affected finish work shall not commence until Developer or Developer's agents have been given a written review of the field samples.

EXHIBIT R

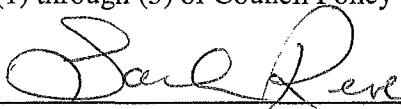
Extra Work Provisions

1. **Extra Work.** City may at any time prior to Project Completion order Extra Work on the Project. The sum of all Extra Work ordered shall not exceed five percent (5%) of the Estimated Cost at the time of Bid Award, without invalidating this Agreement and without notice to any surety.
 - A. *Requests in Writing.* All requests for Extra Work shall be in writing, and shall be treated as and are subject to the same requirements as Change Orders. Developer shall not be responsible for failure to perform Extra Work, which was requested in a manner inconsistent with this Section.
2. **Bonds Required for Extra Work.** Developer's and Developer's agents' bonds, under Article XVII, shall cover any Extra Work provided that the Extra Work is paid for by the Project Budget.
3. **Reimbursement for Extra Work.** Work performed by Developer as Extra Work is reimbursable in the same manner as described in Article XII. The Project Contingency as described in Article III, will be used first to cover the costs of Extra Work.
4. **Markup.** Developer will be paid a reasonable allowance for overhead and profit. The allowance shall not exceed five percent (5%) and shall be added to the Developer's costs for Extra Work.

EXHIBIT S

Notification of Reimbursable Project

Pursuant to Section 12.1.1 of the Reimbursement Agreement with PARDEE HOMES for Financing Plan Project No. T-4.2, CARMEL VALLEY ROAD (4/6 LANES SOUTH OF DEL MAR HEIGHTS ROAD-PHASE II), in the PACIFIC HIGHLANDS RANCH Community, adopted pursuant to City Council Resolution/Ordinance No. _____ and executed on _____, PARDEE HOMES hereby notifies the City of San Diego that work will begin on CARMEL VALLEY ROAD (4/6 LANES SOUTH OF DEL MAR HEIGHTS ROAD-PHASE II) in the PACIFIC HIGHLANDS RANCH community on or about [Insert Date Work is Scheduled to Begin].

This Notification of Reimbursable Project form shall be submitted with the Project's construction permit application to the City's Development Services Department prior to commencement of any work on construction Project No. 381502, Development Services Deposit Account No. 24004993.

The Developer shall add the following note above the title block on the construction plan cover sheet, and on all sheets where subject to reimbursement:

REIMBURSABLE PROJECT: PACIFIC HIGHLANDS RANCH, PROJECT NO. T-4.2 (PHASE II)

This note is required to be submitted with the application for the Project's construction permit.

PARDEE HOMES,
a California corporation

By: _____

[Insert Title] _____

Dated: _____

EXHIBIT T

Reimbursement Request Form

Change Order Request	No.
----------------------	-----

 or

Invoice Approval Request	No.
--------------------------	-----

Project Name	PFFP Project No:
Project Manager	Date Requested
Requested by	Date Approval Requested

Scope of Work Covered by Submittal:

Line Item	Qty	Units	Unit Price	Cost		
				Previous	Current	Total To Date
1.						
2.						
3.						
4.						
5.						
6.						
7.						

(Use separate form for additional items)

Total Requested for this Submittal		
------------------------------------	--	--

Justification for Change/Extra
Impacts, Adds, Deducts, Schedule Impacts, etc

Date	Developer	Title/Signature
------	-----------	-----------------

*I hereby certify that this information is true and accurate and is not part of a previously approved submittal

Approvals

Date	Field Division	Inspector Name/Signature
------	----------------	--------------------------

This work is within and pertains directly to the limits of the approved project and the quantity is consistent with measurements of work installed in the field.

Comments:

Date	Consultant	Printed Name/Signature
------	------------	------------------------

We have reviewed this request with respect to the Developer's Reimbursement Agreement and industry practices and have the following recommendations:

Items _____ are recommended for approval

Total Recommended Amount	Previous	Current	To Date
--------------------------	----------	---------	---------

Items _____ are not recommended for approval. <Comments>

Date	Facilities Financing	Printed Name/Signature
------	----------------------	------------------------

The reimbursement request items noted above are accepted and considered reimbursable as presented.

Comments:

COMPLETED BY DEVELOPER

COMPLETED BY INSPECTOR

COMPLETED BY CONSULTANT/FORMER

COMPLETED BY FACILITIES FINANCING

¹ Approval denotes the acceptability of change under the reimbursement agreement. Reimbursement is contingent upon work acceptance by City.

EXHIBIT U

Project Deliverables

- A. *Working Drawings.* Developer shall prepare Working Drawings in accordance with City's most current drawing format as outlined in City of San Diego's Manual of Preparation of Land Development and Public Improvement Plans.
- i. *Quality.* Developer shall make Working Drawings by one of the following methods: permanent ink, Computer Aided Drafting, a permanent photographic reproduction process, or with pencil made for use on drafting film and permanently fixed with spray coating. Scale and clarity of detail shall be suitable for half-size reduction.
 - ii. *Font and Contents.* Specifications shall be typewritten with one type face, using carbon ribbon or equivalent on bond paper utilizing Greenbook format. Developer will furnish only the technical "Special Provisions" section of the Specifications to supplement or modify the Greenbook standards as needed.
- B. *Surveys.* Developer shall provide all surveying services required for the design of this Project in accordance with all applicable legal regulations, the Technical Guidelines produced by the California Council of Civil Engineers & Land Surveyors under the title "A Guide to Professional Surveying Procedures," and the City of San Diego Engineering and Capitol Projects Department's "Data Standards for Improvement Plans," August 2004.
- C. *Schematic Design Documents.* Developer shall consult with City to ascertain requirements of the Project and to prepare Schematic Design Documents.
- i. Schematic Design Documents shall include, but not be limited to the following:
 - a. Sketches with sufficient detail to illustrate the scale and location of Project components.
 - b. Floor plans with sufficient cross-sections to illustrate the scale and relationship of building components, exterior elevations and exterior colors and textures.
 - c. Analysis of parameters affecting design and construction for each alternate considered.
 - d. Description and recommendation for structural, mechanical and electrical systems, showing alternatives considered.
 - e. Probable construction costs for the base Project and all additive alternates considered.
 - f. Summary of Project requirements and a recommendation.
 - g. Artistic renderings of the Project.
 - ii. *Form.* Developer's Schematics shall conform to the quality levels and standards in size, equipment, and all facets of its design and deliverables as set forth in City specifications and as may be updated prior to commencement of construction.
- D. *Design Development Documents.* Developer shall prepare from the approved Schematic Design Documents, for approval by City, Design Development Documents to fix and describe the size and character of the entire Project. These documents shall contain, at a minimum, the following:
- i. Site plan, indicating the nature and relational location, via dimensions, of all proposed Project components.
 - ii. Traffic circulation and landscaping should also be indicated at this stage if applicable.
 - iii. Plans, elevations, cross-sections, and notes as required to fix and describe the Project components.
 - iv. Proposed construction schedules.
 - v. Technical 'Special Provisions' section of the Specifications.
 - vi. Outline of Specifications prepared in accordance with the latest recommended format of the Construction Specification Institute.
 - vii. Probable Project construction costs, for each component of the Project being considered in this phase.
 - viii. Color board with material samples.

- E. *Construction Documents.* Developer shall provide, based on the approved Design Development documents, Working Drawings and Contract Specifications (throughout the Agreement and attached exhibits referred to as Construction Documents) setting forth in detail the requirements for construction of the Project, including the necessary bidding information.
- F. *Utility Location Requests.* Along with initial submission of Construction Documents, Developer shall furnish copies of the Service and Meter Location Request and all utility companies' verifications.
- G. *Cost Estimate.* Developer shall provide a construction cost estimate based on the Construction Documents.
- H. *H, G, & E Reports.* Developer shall provide hydrologic, geotechnical, environmental documents, and other related documents or reports as required by City.
- I. *As-Builts.* Developer shall provide As-Builts.
 - i. As-Builts shall show by dimension accurate to within one (1) inch, the centerline of each run of conduits and circuits, piping, ducts, and other similar items as determined by City, both concealed and visible. Developer shall clearly identify the item by accurate note such as "cast iron drain," galvanized water, etc. Developer shall clearly show, by symbol or note, the vertical location of the item ("under slab," "in ceiling," "exposed," etc.), and make all identification sufficiently descriptive that it may be related reliably to the specification. Developer shall thoroughly coordinate all changes on the As-Builts making adequate and proper entries on each page of specifications and each sheet of drawings and other documents where entry is required to properly show the change.
 - ii. Developer shall include all of the following on the As-Builts:
 - a. Depth of foundation in relation to finished first floor.
 - b. Horizontal and vertical locations of underground utilities and appurtenances, with references to permanent surface improvements.
 - c. Locations of internal utilities and appurtenances, with references to visible and accessible features of the structure.
 - d. Field changes of dimensions and details.
 - e. Changes authorized by approved proposal requests, construction change orders, discussion with City that resulted in any change/deviation from City's program, specifications, approved plans, equipment or materials.
 - f. Details not issued with original contract drawings, design/build plans, deferred approvals, etc.
 - g. Upon completion of work, obtain signature of licensed surveyor or civil engineer on the Project record set verifying layout information.
 - h. Show locations of all utilities on-site with size, and type of pipe, if different than specified, and invert elevations of pipe at major grade and alignment changes.
 - i. The title "PROJECT RECORD" in 3/8" letters.
 - iii. Developer shall maintain a set of As-Builts at the Project site for reference. Developer shall ensure that changes to the As-Builts are made within twenty-four hours after obtaining information. Changes shall be made with erasable colored pencil (not ink or indelible pencil), shall clearly describe the change by note (note in ink, colored pencil or rubber stamp) and by graphic line, shall indicate the date of entry, shall circle the area or areas affected and, in the event of overlapping changes, use different colors for each change.
- J. *As-Graded Reports.* Developer shall submit the City approved As-Graded Report summarizing the results of the observations and testing of grading operations.
- K. *Signed Grading and/or Public Right-of-Way Permit.* The Developer shall submit the signed grading and/or public right-of-way permit.
- L. *Operation and Maintenance Manuals.* Developer shall submit all Operation and Maintenance manuals prepared in the following manner:
 - i. In triplicate, bound in 8½ x 11 inch (216 x 279 mm) three-ring size binders with durable plastic covers prior to City's Final Inspection.

- ii. A separate volume for each system, including but not limited to mechanical, electrical, plumbing, roofing, irrigation, and any other system as determined by City, with a table of contents and index tabs in each volume as follows:
 - a. Part 1: Directory, listing names, addresses, and telephone numbers of Developer's agents, suppliers, manufacturers, and installers.
 - b. Part 2: Operation and Maintenance Instructions, arranged by specification division or system. For each specification division or system, provide names, addresses and telephone numbers of Developer's agents, suppliers, manufacturers, and installers. In addition, list the following: 1) appropriate design criteria; 2) list of equipment; 3) parts list; 4) operating instructions; 5) maintenance instructions, equipment; 6) maintenance instructions, finishes; 7) shop drawings and product data; and 8) warranties.
- M. *Capitalization Form*. The Developer shall submit all required capitalization information in a form acceptable to the Facilities Financing Project Manager.
- N. *Certificate of Occupancy/Property Transfers*. The Developer shall submit any required certificates of occupancy and/or property transfers.

EXHIBIT V

Sample Capitalization Form: Capitalization Form to be completed by Developer initially upon receipt of Substantial Completion Letter (90%) from City Engineering Department. Capitalization Form to be updated upon final completion of Project (100%) to reflect all verified project costs.

Capitalization Cost Breakdown For Developer Built Reimbursable Public Projects

1) Project Title/Location:	5) Permit Number:
2) Project (PTS) Number:	6) Substantial Completion Letter Date:
3) Internal Order Number:	7) As-Built Date:
4) Drawing Number:	8) PFFF Ref. #:
	Reimb. Agreement Resolution #:
	Date Approved:

(1) Item	(2) Description	(3) Asset Code	(4) Quantity #	(5) Unit Measurement	(6) Total Cost *
STREETS **					
Roadways		ROAD		SF	
Sidewalk		SIDE		SF	
Curb & Gutter		SIDE		LF	
Curb Ramps		SIDE		Each	
Medians		SIDE		SF	
Alleys		ALLY		SF	
Traffic Signals		TRAF		Each	
Street Lights		STAT		Each	
Guardrails		STRT		LF	
BRIDGES					
Vehicular/Wildlife		BRDG		SF	
Pedestrian		BRDG		SF	
Other (Specify)					
STORM DRAINS					
Storm Drains		STRM		LF	
Channels & Culverts		CHAN		LF	
Other (Specify)					
PARK INFRASTRUCTURE (Use)					
Parkgrounds		PARK		Each/Acres	
Picnic Shelter		PARK		Each	
Playground		PARK		Each	
Recreation Center		3008		Each/SF	
Comfort Stations		3008		Each	
Park Lighting		PARK		Each	
Pool		PARK		Each	
Bike Path or Multi-Use Trails		PATH		LF	
Parking Lot		LOTS		SF	
OTHER (Use)					
Pedestrian Lighted Crosswalk		TRAF			
Fire Station		various			
Library					
Police Station					
Total Project Cost					\$ -

I CERTIFY THAT TO THE BEST OF MY KNOWLEDGE, THE INFORMATION PROVIDED ON THIS CAPITALIZATION FORM IS TRUE AND ACCURATE REGARDING THE CITY ACQUIRED INFRASTRUCTURES. PRINT NAME: _____ TITLE: _____ SIGNATURE: _____ DATE: _____	Name/Title _____ Contact No. _____ Prepared by: _____
	City Use Only-Forward Original to Facilities Financing for Distribution

* Project soft cost for administration, engineering, design, etc. should be allocated using the percentage of hard cost for each cost category. ** Water & Sewer capitalized by PUD.	Copy Auditor- CIP Fixed Asset Acct. MS EA Copy Street Division-MS 44 Copy Development Services Department
---	---

EXHIBIT W

Typical Insurance Provisions

1. **Types of Insurance.** At all times during the term of this Agreement and for so long as the Agreement requires, Developer shall maintain insurance coverage as follows:
 - 1.1 Commercial General Liability. Developer shall provide at its expense a policy or policies of Commercial General Liability (CGL) Insurance written on an ISO Occurrence form CG 00 01 07 98 or an equivalent form providing coverage at least as broad and which shall cover liability arising from premises and operations, XCU (explosions, underground, and collapse) independent contractors, products/completed operations, personal injury and advertising injury, bodily injury, property damage, and liability assumed under an insured's contract (including the tort liability of another assumed in a business contract). There shall be no endorsement or modification of the CGL Insurance limiting the scope of coverage for either "insured vs. insured" claims or contractual liability. Developer shall maintain the same or equivalent CGL Insurance as described herein for at least ten (10) years following substantial completion of the work. All costs of defense shall be outside the policy limits. The Policy shall provide for coverage in amounts not less than the following: (i) General Annual Aggregate Limit (other than Products/Completed Operations) of two million dollars (\$2,000,000); (ii) Products/Completed Operations Aggregate Limit of two million dollars (\$2,000,000); (iii) Personal Injury Limit one million dollars (\$1,000,000); and (iv) Each Occurrence one million dollars (\$1,000,000).
 - 1.2 Commercial Automobile Liability. For all of Developer's automobiles used in conjunction with the Project including owned, hired and non-owned automobiles, Developer shall keep in full force and effect, a policy or policies of Commercial Automobile Liability Insurance written on an ISO form CA 00 01 12 90 or a later version of this form or equivalent form providing coverage at least as broad in the amount of one million dollars (\$1,000,000) combined single limit per occurrence, covering bodily injury and property damage for owned, non-owned and hired automobiles ("Any Auto"). All costs of defense shall be outside the policy.
 - 1.3 Architects and Engineers Professional Liability. For all of Developer's employees who are subject to this Agreement, Developer shall keep in full force and effect, or Developer shall require that its architect/engineer(s) of record keep in full force and effect errors and omissions insurance providing coverage for professional liability with a combined single limit of one million dollars (\$1,000,000) per claim and two million dollars (\$2,000,000) annual aggregate. Developer shall ensure both that (i) this policy retroactive date is on or before the date of commencement of the Project; and (ii) this policy has a reporting period of three (3) years after the date of completion or termination of this Contract. Developer agrees that for the time period defined above, there will be no changes or endorsements to the policy that increases the City's exposure to loss.
 - 1.4 Worker's Compensation. For all of Developer's employees who are subject to this Contract and to the extent required by the State of California, Developer shall keep in full force and effect, a Workers' Compensation Insurance and Employers' Liability Insurance to protect Developer against all claims under applicable state workers' compensation laws. The City, its elected officials, and employees will not be responsible for any claims in law or equity occasioned by the failure of the Developer to comply with the requirements of this section. That policy shall provide at least the Statutory minimums of one million dollars (\$1,000,00) for Bodily Injury by Accident for each accident, one million dollars (\$1,000,000) for Bodily Injury by Disease each employee, and a one million dollars (\$1,000,000) for Bodily Injury by Disease policy limit. Developer shall provide an endorsement that the insurer waives the right of subrogation against the City and its respective elected officials, officers, employees, agents and representatives.
 - 1.4.1 Prior to the execution of the Agreement by the City, the Developer shall file the following signed certification:

"I am aware of the provisions of Section 3700 of the Labor Code which requires every employer to be insured against liability for worker's compensation or to

undertake self-insurance, in accordance with the provisions of that code, and I will comply with such provisions before commencing the performance of the work of the Contract.”

- 1.5 Builder’s Risk. To the extent commercially available, Developer shall provide a policy of “all risk” Builders Risk Insurance. Developer shall add City and its respective elected officials, officers, employees, agents, and representatives to the policy as additional named insureds or loss payees, to the extent such insurance is commercially available. Developer shall also add its construction contractor, and the construction contractor’s subcontractors to the policy as additional named insureds or loss payees, to the extent such insurance is commercially available. The insurance may provide for a deductible which shall not exceed fifty thousand dollars (\$50,000). It shall be Developer’s responsibility to bear the expense of this deductible. The Builders Risk coverage shall expire at the time such insured property is occupied by City, or a Notice of Completion is filed, whichever occurs first.
2. **Endorsements Required.** Each policy required under Section 1, above, shall expressly provide, and an endorsement shall be submitted to the City, that:
 - 2.1 *Additional Insureds.* Except as to Architects and/or Engineers professional liability insurance and Workers Compensation, the City of San Diego and its respective elected officials, officers, employees, agents, and representatives shall be named as additional insureds.
 - 2.1.1 *Commercial General Liability.* The policy or policies must be endorsed to include as an Insured the City of San Diego and its respective elected officials, officers, employees, agents, and representatives. The coverage for Projects for which the Engineer’s Estimate is one million dollars (\$1,000,000) or more shall include liability arising out of: (i) Ongoing operations performed by you or on your behalf, (ii) Your products, (iii) Your work, including but not limited to your completed operations performed by you or on your behalf, or (iv) premises owned, leased, controlled, or used by you; the coverage for Projects for which the Engineer’s Estimate is less than one million dollars (\$1,000,000) shall include liability arising out of: (i) Ongoing operations performed by you or on your behalf, (ii) Your products, or (iii) premises owned, leased, controlled, or used by you; Except that in connection with, collateral to, or affecting any construction contract to which the provisions of subdivision (b) of Section 2782 of the California Civil Code apply, these endorsements shall not provide any duty of indemnity coverage for the active negligence of the City of San Diego and its respective elected officials, officers, employees, agents, and representatives in any case where an agreement to indemnify the City of San Diego and its respective elected officials, officers, employees, agents, and representatives would be invalid under subdivision (b) of Section 2782 of the California Civil Code. In any case where a claim or loss encompasses the negligence of the Insured and the active negligence of the City of San Diego and its respective elected officials, officers, employees, agents, and representatives that is not covered because of California Insurance Code Section 11580.04, the insurer’s obligation to the City of San Diego and its respective elected officials, officers, employees, agents, and representatives shall be limited to obligations permitted by California Insurance Code Section 11580.04.
 - 2.1.2 *Commercial Automobile Liability Insurance.* Unless the policy or policies of Commercial Auto Liability Insurance are written on an ISO form CA 00 01 12 90 or a later version of this form or equivalent form providing coverage at least as broad, the policy or policies must be endorsed to include as an Insured the City of San Diego and its respective elected officials, officers, employees, agents, and representatives, with respect to liability arising out of automobiles owned, leased, hired or borrowed by or on behalf of the Developer; except that in connection with, collateral to, or affecting any construction contract to which the provisions of subdivision (b) of Section 2782 of the California Civil Code apply, this endorsement shall not provide any duty of indemnity coverage for the active negligence of the City of San Diego and its respective elected officials, officers, employees, agents, and representatives in any case where an agreement to indemnify the City of San Diego and its respective elected officials, officers, employees, agents, and representatives would be invalid under subdivision (b) of Section 2782 of the California

Civil Code. In any case where a claim or loss encompasses the negligence of the Insured and the active negligence of the City of San Diego and its respective elected officials, officers, employees, agents, and representatives that is not covered because of California Insurance Code Section 11580.04, the insurer's obligation to the City of San Diego and its respective elected officials, officers, employees, agents, and representatives shall be limited to obligations permitted by California Insurance Code Section 11580.04.

- 2.2 *Primary and Non-Contributory.* The policies are primary and non-contributing to any insurance or self-insurance that may be carried by the City of San Diego, its elected officials, officers, employees, agents, and representatives with respect to operations, including the completed operations if appropriate, of the Named Insured. Any insurance maintained by the City of San Diego and its elected officials, officers, employees, agents, and representatives shall be in excess of Developer's insurance and shall not contribute to it.
- 2.3 *Project General Aggregate Limit.* The CGL policy or policies must be endorsed to provide a Designated Construction Project General Aggregate Limit that will apply only to the work performed under this Agreement. Claims payments not arising from the work shall not reduce the Designated Construction Project General Aggregate Limit. The Designated Construction Project General Aggregate Limit shall be in addition to the aggregate limit provided for the products-completed operations hazard.
- 2.4 *Written Notice.* Except as provided for under California law, the policies cannot be canceled, non-renewed or materially changed except after thirty (30) calendar days prior written notice by Developer to the City by certified mail, as reflected in an endorsement which shall be submitted to the City, except for non-payment of premium, in which case ten (10) calendar days notice shall be provided.
- 2.5 The words "will endeavor" and "but failure to mail such notice shall impose no obligation or liability of any kind upon the company, its agents, or representatives" shall be deleted from all certificates.

2015 = 56, July 14

(O-2015-119)

ORDINANCE NUMBER O- 20519 (NEW SERIES)

DATE OF FINAL PASSAGE JUL 28 2015

AN ORDINANCE OF THE COUNCIL OF THE CITY OF SAN DIEGO TO AUTHORIZE A REIMBURSEMENT AGREEMENT FOR PROJECT NO. T-4.2, CARMEL VALLEY ROAD, IN THE PACIFIC HIGHLANDS RANCH COMMUNITY.

WHEREAS, on September 24, 2002, the City approved Vesting Tentative Map No. 7248 for Units #5-11, by San Diego Resolution R-297087, subject to certain conditions determined necessary for the development of Pardee Homes (Pardee); and

WHEREAS, on April 10, 2012, by San Diego Resolution R-307364, the City Council adopted the Pacific Highlands Ranch Public Facilities Financing Plan and Facilities Benefit Assessment (FBA) for Fiscal Year 2013 (Financing Plan), on file in the Office of the City Clerk as Document No. RR-307364. The Financing Plan identifies Project No. T-4.2, Carmel Valley Road (4/6 lanes south of Del Mar Heights Road); and

WHEREAS, Pardee plans to design and construct Project No. T-4.2 relating to Carmel Valley Road (4/6 lanes south of Del Mar Heights Road)(Project); NOW, THEREFORE,

BE IT ORDAINED, by the Council of the City of San Diego, as follows:

Section 1. That the Mayor is authorized to execute, for and on behalf of City, a Reimbursement Agreement with Pardee for the purchase, design, and construction of Project No. T-4.2, in the Pacific Highlands Ranch community, on file in the Office of the City Clerk as Document No. OO- 20519 (Agreement), under the terms and conditions set forth in the Agreement.

Section 2. That the City hereby waives the consultant selection requirements of San Diego Municipal Code section 22.3202, Council Policy 300-07, and Council Policy 100-10 as to the following consultants: (1) Latitude 33 Planning and Engineering for civil engineering; (2) SJA Inc. and Mark Lloyd for landscape architecture and land planning; (3) MJS Construction for management and engineering; (4) Urban Systems Associates, Inc. for traffic engineering; (5) Utility Specialists Southwest, Inc. for public utility services; (6) KCM Group for project management; and (7) Geocon Consultants, Inc. for geotechnical engineering.

Section 3. That the Chief Financial Officer is authorized to appropriate and expend an amount not to exceed \$1,801,000.00 from CIP No. S-00900, Carmel Valley Road, Fund No. 400090, Pacific Highlands Ranch Facilities Benefit Assessment FBA, consistent with the timing established in the most recently adopted Pacific Highlands Ranch Public Facilities Financing Plan, and contingent upon the Chief Financial Officer furnishing one or more certificate(s) certifying that funds necessary for expenditure are, or will be, on deposit in the City Treasury.

Section 4. That the Chief Financial Officer is authorized upon advice from the administering department, to transfer excess funds, if any, to the appropriate reserves.

APPROVED: JAN I. GOLDSMITH, City Attorney

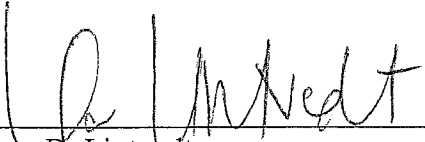
By 
Inga B. Lintvedt
Deputy City Attorney

IBL: mm
5/13/2015
Or.Dept:Planning
Doc. No.: 845589

I hereby certify that the foregoing Ordinance was passed by the Council of the City of San Diego, at this meeting of JUL 14 2015.

ELIZABETH S. MALAND
City Clerk

By *Mary Fernandez*
Deputy City Clerk

Approved: 7/22/15
(date)

Kevin L. Faulconer
KEVIN L. FAULCONER, Mayor

Vetoed: _____
(date)

KEVIN L. FAULCONER, Mayor

Passed by the Council of The City of San Diego on JUL 14 2015, by the following vote:

Councilmembers	Yeas	Nays	Not Present	Recused
Sherri Lightner	<input checked="" type="checkbox"/>	<input type="checkbox"/>	<input type="checkbox"/>	<input type="checkbox"/>
Lorie Zapf	<input checked="" type="checkbox"/>	<input type="checkbox"/>	<input type="checkbox"/>	<input type="checkbox"/>
Todd Gloria	<input checked="" type="checkbox"/>	<input type="checkbox"/>	<input type="checkbox"/>	<input type="checkbox"/>
Myrtle Cole	<input checked="" type="checkbox"/>	<input type="checkbox"/>	<input type="checkbox"/>	<input type="checkbox"/>
Mark Kersey	<input checked="" type="checkbox"/>	<input type="checkbox"/>	<input type="checkbox"/>	<input type="checkbox"/>
Chris Cate	<input checked="" type="checkbox"/>	<input type="checkbox"/>	<input type="checkbox"/>	<input type="checkbox"/>
Scott Sherman	<input checked="" type="checkbox"/>	<input type="checkbox"/>	<input type="checkbox"/>	<input type="checkbox"/>
David Alvarez	<input checked="" type="checkbox"/>	<input type="checkbox"/>	<input type="checkbox"/>	<input type="checkbox"/>
Marti Emerald	<input checked="" type="checkbox"/>	<input type="checkbox"/>	<input type="checkbox"/>	<input type="checkbox"/>

Date of final passage JUL 28 2015.

AUTHENTICATED BY:

KEVIN L. FAULCONER
Mayor of The City of San Diego, California.

(Seal)

ELIZABETH S. MALAND
City Clerk of The City of San Diego, California.

By Mary Hernandez, Deputy

I HEREBY CERTIFY that the foregoing ordinance was not finally passed until twelve calendar days had elapsed between the day of its introduction and the day of its final passage, to wit, on

JUN 23 2015, and on JUL 28 2015.

I FURTHER CERTIFY that said ordinance was read in full prior to passage or that such reading was dispensed with by a vote of five members of the Council, and that a written copy of the ordinance was made available to each member of the Council and the public prior to the day of its passage.

(Seal)

ELIZABETH S. MALAND
City Clerk of The City of San Diego, California.

By Mary Hernandez, Deputy

Office of the City Clerk, San Diego, California

Ordinance Number O- 20519

Passed by the Council of The City of San Diego on July 14, 2015, by the following vote:

YEAS: LIGHTNER, ZAPP, GLORIA, COLE, KERSEY, CATE,
SHERMAN, ALVAREZ, EMERALD.
NAYS: NONE.
NOT PRESENT: NONE.
RECUSED: NONE.

AUTHENTICATED BY:

KEVIN L. FAULCONER

Mayor of The City of San Diego, California

ELIZABETH S. MALAND

City Clerk of The City of San Diego, California

(Seal)

By: Jeannette I. Santos, Deputy

I HEREBY CERTIFY that the above and foregoing is a full, true and correct copy of ORDINANCE NO. O-20519 (New Series) of The City of San Diego, California.

I FURTHER CERTIFY that said ordinance was not finally passed until twelve calendar days had elapsed between the day of its introduction and the day of its final passage, to wit, on June 23, 2015 and on July 28, 2015.

I FURTHER CERTIFY that said ordinance was read in full prior to passage or that such reading was dispensed with by a vote of five members of the Council, and that a written copy of the ordinance was made available to each member of the Council and the public prior to the day of its passage.

ELIZABETH S. MALAND

City Clerk of The City of San Diego, California

(SEAL)

By:  Deputy