



BALBOA PARK SIGN MANUAL UPDATE

ADOPTED BY THE BALBOA PARK COMMITTEE ON
SEPTEMBER 5TH, 2019

BALBOA PARK SIGN MANUAL

Prepared for
The City of San Diego, California

Prepared by



Original document previously provided by



The following sign manual is for guideline use only.

All final details will be needed to work through with fabricator prior to installation.

TABLE OF CONTENTS

SECTION 1

INTRODUCTION

SECTION 2

THE BRAND

SECTION 3

SIGNAGE SPECIFICATIONS

SECTION 4

NEW PROPOSED SIGNAGE

SECTION 5

POLE, MOUNTING & BASE SPECIFICATIONS

SECTION 6

PROGRAMMING

FIGURES

- FIGURE 1** - Logo
- FIGURE 2** - Historical Logo
- FIGURE 3** - Logo Regulations
- FIGURE 4** - Type style
- FIGURE 5** - Icons & Arrows
- FIGURE 6** - Brand Signage Example
- FIGURE 7** - District Map
- FIGURE 8** - Districts Colors
- FIGURE 9** - Districts and Colors
- FIGURE 10** - Pedestrian Districts
- FIGURE 11** - Prado Map
- FIGURE 12** - Prado Signage
- FIGURE 13** - Palisade map
- FIGURE 14** - Mapping Districts
- FIGURE 15** - Off-Site Directionals
- FIGURE 16** - Tram Stop
- FIGURE 16A** - Tram Stop (Details)
- FIGURE 16B** - Tram Stop Pole for Overall Park
- FIGURE 16C** - Tram Stop Pole for Prado Area
- FIGURE 17** - Auto Traffic Directional
- FIGURE 17A** - Auto Traffic Directional (Details)
- FIGURE 17B** - Auto Traffic Directional (B&W)
- FIGURE 17C** - Auto Traffic Directional (B&W)
- FIGURE 17D** - Auto Traffic Directional for Overall Park
- FIGURE 17E** - Auto Traffic Directional for Prado Area
- FIGURE 18** - Auto Traffic Signs
- FIGURE 18A** - Auto Traffic Signs (Details)
- FIGURE 18B** - Auto Traffic Pole for Overall Park
- FIGURE 18C** - Auto Traffic Pole for Prado Area
- FIGURE 19** - Pedestrian Orientation
- FIGURE 19A** - Pedestrian Orientation (Details)
- FIGURE 19B** - Pedestrian Orientation Pole for Overall Park
- FIGURE 19C** - Pedestrian Orientation Pole for Prado Area
- FIGURE 20** - Pedestrian Directional
- FIGURE 20A** - Pedestrian Directional (details)
- FIGURE 20B** - Pedestrian Directional (B&W)
- FIGURE 20C** - Pedestrian Directional Pole for Overall Park
- FIGURE 20D** - Pedestrian Directional Pole for Prado Area
- FIGURE 21** - Oval Hanging/Wall-Mounted Building
- FIGURE 21A** - Oval Hanging/Wall-Mounted Building (Details)
- FIGURE 22** - Restroom Identity
- FIGURE 23** - 1-Sided Building & Location
- FIGURE 23A** - 1-Sided Building & Location (Details)
- FIGURE 23B** - 1-Sided Building & Location Pole for Overall Park
- FIGURE 23C** - 1-Sided Building & Location Pole for Prado Area
- FIGURE 24** - 2-Sided Building & Location
- FIGURE 24A** - 2-Sided Building & Location (Details)
- FIGURE 24B** - 2-Sided Building & Location Pole for Overall Park
- FIGURE 24C** - 2-Sided Building & Location Pole for Prado Area
- FIGURE 25** - Banner Standard
- FIGURE 25A** - Banner Standard (Historical Area)
- FIGURE 26** - 1-Sided Historical Landmark
- FIGURE 26A** - 1-Sided Historical Landmark (Details)
- FIGURE 26B** - 1-Sided Historical Landmark Pole
- FIGURE 27** - High Speed Vehicular Directional
- FIGURE 27A** - High Speed Vehicular Directional (Details)
- FIGURE 28** - Amenity Identity Monument
- FIGURE 28A** - Amenity Identity Monument
- FIGURE 28B** - Amenity Identity Monument (Details)
- FIGURE 29** - Balboa Park Identity
- FIGURE 29A** - Balboa Park Identity (Details)
- FIGURE 30** - Parking Lot Identity
- FIGURE 30A** - Parking Lot Identity (Details)
- FIGURE 31** - Parking Lot Digital
- FIGURE 32** - Parking Identity
- FIGURE 33** - Tram Stop
- FIGURE 33A** - Tram Stop (Details)
- FIGURE 34** - Pedestrian Directional/Directory
- FIGURE 34A** - Pedestrian Directional/Directory (Details)
- FIGURE 35** - Rules & Regulations
- FIGURE 35A** - Rules & Regulations (Details)
- FIGURE 36** - Mariner Pole & Base
- FIGURE 37** - Mariner Pole Cap
- FIGURE 38** - Mini-Mariner Pole & Base
- FIGURE 39** - Mini-Mariner Pole Cap
- FIGURE 40** - Capistrano Pole & Base
- FIGURE 41** - Capistrano Pole Cap
- FIGURE 42** - Typical Bracket & Sign Connection
- FIGURE 43** - Sign & Pole Design Connection
- FIGURE 44** - Wall Mount Design Connection
- FIGURE 45** - Hanging Sign Connection
- FIGURE 46** - Programming
- FIGURE 47-58** - Sign Location Plan
- FIGURE 59 & 60** - Sign Type Implementation Priorities
- FIGURE 61 & 62** - Sign System Budgetary Estimates

SECTION 1

INTRODUCTION

INTRODUCTION

The signing and information element of the Balboa Park Master Plan recommends the development of a comprehensive sign manual to uniformly regulate all park signs.

Previous sign programs failed to regulate individual park tenants who undertook their own signing without regard to a unifying standard. The lack of park-wide signing authority resulted in the current collection and proliferation of unrelated signs in Balboa Park.

If a park sign program is to succeed, then all park institutions, concessionaires, special interests and special events must conform to a unified signing program with no exceptions.

Citizens, park committees, park institutions and city staff agree that the image of Balboa Park is incomplete, inconsistent and not equal to the Park's potential. Therefore, the purpose of this manual is to correct the undesirable conditions by introducing an image and signing guidelines for Balboa Park that is enforceable in Balboa Park.

SIGN GUIDELINES

Balboa Park is composed of the historical Central Mesa with almost all of the buildings representing the 1915 and 1935 Exposition style, and two other mesas that have evolved to the present with no particular architecturally dominant style. The sign program in the park must be flexible enough physically and visually to adapt to all three mesas of Balboa Park.

The premises for the sign program in Balboa Park is based on signs used in the park for the 1915 Exposition. As shown in the photo next page, the new sign program will take the basic concepts and adapt them to present and future needs and constraints.

Replacement, reconstruction and new construction of signs shall strictly adhere to standards set herein. Standards include sign size and shape, letter weight and styles, logo use, content and length of message, pole standard style, attachment method, materials, color and sign locations.

All traffic signs within park land (i.e. parking, handicapped, stop) shall be regulated by city sign regulations. This manual covers sign position on pole and pole standard selection. **(FIGURE 13)**

All specific institution, concessionaire or special interest signs, shall be limited to pedestrian orientation signs (specific area map), pedestrian directional signs, and location building ID signs.

All automobile signs shall be limited to generic destinations. No specific institution signs shall be allowed. The San Diego Zoo is the only exception to this rule due to the area it occupies. The word “Zoo” is all that shall be labeled. All automobile directional signs shall be restricted to areas where public vehicles are allowed.

All listings on directional signs will be hierarchy of locations starting with the straight ahead arrow, to the right arrow and to the left arrow. At the top will be the Balboa logo, underneath where the message area is will include walking time and at the bottom will be the district name and color. Directions to restrooms should appear on all pedestrian directionals when within 500 feet of a public restroom. Quantity of listings determined by length of listing and size of sign.

Message, type sized and quantities for permanent signs are limited.

1915 EXPOSITION SIGN



COMPLIANCE

The Park and Recreation Board, through chosen subcommittees (currently the Balboa Park Committee) shall be responsible to certify compliance with the Sign Manual. Signs on city streets in Balboa Park shall be considered as park signs for the purposes of this manual. Park Boards and City Council should be the final authorities on implementation of these guidelines.

Signs proposed for the historical landmark area shall be certified by the Park and Recreation Board and the Historical Resources Board as to compatibility of intent with applicable laws governing the site. **(FIGURES 2 & 20)**

Tenants' and concessionaires' signs (includes advertising) which are visible from the street rights-of-way, park roads, park parking lots and open park land shall be subject to this Manual and approval requirements.

Banners shall be certified by the Park Boards in all cases and by the Historical Resources Board when within the historic Landmark District. There will be a time limit on the life of all temporary signs. Park Boards should be the final authorities on implementation of these guidelines.

No existing park and tenant signs, permanent or temporary, shall be granted "grandfather" status, and all are subject to ultimate conformance with this Manual.

Existing 3" diameter pole standards found throughout the park may be retrofitted to current standards by straightening the pole, installing the park base and cap, then painting the standard, sign back and brackets the required park color. (MP20189 Corinthian Bronze Metallic)

The 2" square tube standard also found throughout the park is not acceptable under any circumstances. These tubes must be replaced with the 3" diameter pole.

Buildings with Existing Wall-Mount Letters

Buildings with wall-mount letters may continue to have individual letters on the same wall provided the type style is Christiana using a capital and lower case configuration and the capital height does not exceed the existing capital height on the building with a maximum of 18 inches. Letters must be flush-mount and pinned. A good example of this is the San Diego Automotive Museum letters.

IMPLEMENTATION

Balboa Park is at once a local, regional and pan-regional resource of extraordinary value to the people of San Diego. It is, in fact, a major facet of the image of San Diego. Though these facets legitimize a special sign program, and such program must compete with sorely needed improvements and maintenance for funding. Staged implementation, therefore, is a necessity.

Approximate costs by area are shown in **FIGURE 57** for area map.

BALBOA PARK IMAGE

The thrust of a comprehensive signing program for Balboa Park is to establish a unified and cohesive “look” to all 1,000 acres. The visually fragmented appearance of the signs and the real lack of park identity from one specific area to another has created the need for a park logo.

Balboa Park is an iconic park of San Diego’s fabric that brings life to the destination. It is a vital, living entity that is both rich in history and transformative by nature. Because the park is ever changing, it is full of unexpected surprises and is never the same experience twice. The logo pays homage to the park’s heritage, beauty and abundance through the iconic California Tower. From land or sky, nothing is more recognizable and breathtaking as the California Tower at Balboa Park. For Balboa Park, it’s a symbolic beacon of elegance and classic beauty.

The Balboa Park logo is made up of two components: the Balboa Park symbol and the logotype. These two components are always placed in a fixed relationship and should never be altered or modified in any way. **(FIGURE 1 & 2)**

The logo, applied to the signage program, will establish the boundaries and interior spaces as Balboa Park land. It will always be white on a dark bronze field.

The Park logo will also be used on all printed matter provided by institutions, committees and special interest groups to further establish the unifying goal of the sign program.

The guidelines of how to and how not to use the Balboa Park logo on signage will be established by this Manual. **(FIGURE 6)** Please reference brand guidelines for required uses on letterheads, mailers, flyers, brochures, tickets, books, and new releases by tenants and Balboa Park officials alike. Leases shall include a performance clause as a mandate to leases to implement this plan.

The logo will be on all directional and orientation signs and some building and location signs. **(FIGURES 15-35)**

Graphic lines, known as rules on all signs, will be 1/8” thick. Length depends on sign layout.

Generic banners should be embellished with the Park logo to further establish the unifying mark. **(FIGURE 25)**

BALBOA PARK OFF-SITE SIGN LOCATIONS

| LOCATIONS | QTY. | ARROW |
|---|------|-------|
| 1. South of Vine St. on Right on Kettner Blvd. | 1 | ST |
| 2. South of Olive St. on Left & Right on Kettner Blvd. | 2 | ST |
| 3. South of Maple St. on Left & Right on Kettner Blvd. | 2 | LT |
| 4. Street light in median East or aircraft crossing on Harbor Blvd. | 1 | LT |
| 5. New pole in planter on Rt. SE of Scenic Dr. Sign on Harbor Dr. | 1 | RT |
| 6. 3rd street light on Rt. between Harbor Dr. & Pac. Hwy on Laurel St. | 1 | ST |
| 7. New pole on Rt. between Kettner Blvd. & India St. on Laurel St. | 1 | ST |
| 8. Street light on Rt. between Kettner Blvd. & Laurel St | 1 | RT |
| 9. New pole on Rt. N. of Laurel St. on 4th between driveways of 1st California Bank | 1 | LT |
| 10. 2nd existing pole on Rt. S. of Laurel St. on 1st Ave. | 1 | RT |
| 11. Remove & replace on 6th Ave. N. of "A" St. on Rt. & Lt. | 2 | LT |
| 12. Remove & replace on "A" St. on Rt. between 7th & 8th Aves. | 1 | ST |
| 13. Remove & replace on "A" St. on Rt. between 10th & 11th Aves. | 1 | ST |
| 14. Remove & replace on "A" St. on Rt & Lt. between 11th & 12th Aves. | 2 | LT |
| 15. "Signal Ahead" pole on Rt. S. of Camino Del Rio S. on Texas St. | 1 | ST |
| 16. New pole on Rt. N. of El Cajon Blvd. between AM/PM driveways on Texas St. | 1 | ST |
| 17. New pole on Rt. N of El Cajon Blvd. near 2232 El Cajon Blvd. | 1 | ST |
| 18. New pole on Rt. on El Cajon Blvd. near 1844 El Cajon Blvd. | 1 | LT |
| 19. Existing pole on Rt. on Park Blvd. between Lincoln Ave. & Centre St. | 1 | ST |
| 20. Remove & replace on University Ave. E of Park Blvd. & under bridge | 1 | LT |
| 21. Remove & replace on University Ave. W. of Park Blvd. | 1 | RT |
| 22. Street light on Rt. between Robinson Ave. & Essex St. on Park Blvd. | 1 | ST |

ARROW LEGEND: ST= STRAIGHT LT= LEFT RT= RIGHT

SIGN SHAPE

Balboa Park sign system consists of two basic shapes.

The Classic Arch

60° oval shape on top of a rectangle with radius lower corners. Approved size variations of this basic shape are possible.

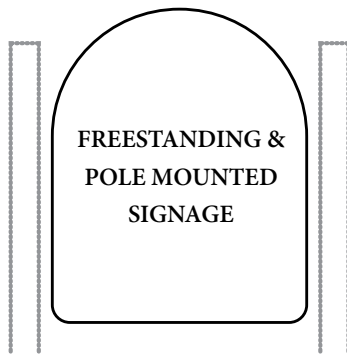

The Oval

30 oval in 3 basic sizes. **(FIGURE 16)** Approved size variations of this basic shape are possible. Traffic sign shapes will be the approved city regulation shapes.

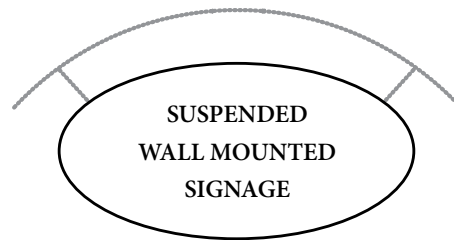

SIGN FORMAT COLORS

















The Color

All signs for Balboa Park shall have a background color of Matthews Paint MP20189 Corinthian Bronze Metallic, with changing district colors at the base of the select sign types. No other background will be approved. Exceptions are required color for city regulation traffic signs. In

most instances the color for all type and graphics will be white Avery Dennison 900 Supercast Opaque Film SC 900-101-0. Exceptions are for maps and the historical landmark logo. In additional all walking times shall be displayed in Avery Dennison 900 Supercast Opaque Film Sandstone SC 900-965-0.





PAINTS

All paints to have Satin Finish unless otherwise specified. All painted surfaces are to be on aluminum.

| | | | | | | | |
|---|---|---|---|---|--|---|---|
|  |  |  |  |  |  |  |  |
|  |  |  |  |  |  |  |  |
| Matthews MP20189 Corinthian Bronze Metallic | Matthews MP16211 Gordal Olive | Matthews MP11228 Great Falls | Matthews MP12385 Clay Beige | Matthews MP01126 Davies Crest Reda | Matthews MP03697 Indiglo | Matthews MP14722 Purple Gallinule | Matthews MP05041 Roseate Spoonbill |
|  |  |  |  |  |  |  |  |
|  |  |  |  |  |  |  |  |
| Matthews MP02643 Amulet Blue | Matthews MP03395 Talavera Tile | Matthews MP12994 Malua Mauve | Matthews MP02795 Spice Trader | Matthews MP12718 Unicor Brown | Matthews MP32156 Black Magic | Matthews MP20158 Statuary Bronze Metallic | Frazee Custom Color CZ-12-2935 |

VINYL

All materials to be provided as 8" x 8" sample or as part of a mock-up for approval.

| | |
|---|---|
|  |  |
|  |  |
| Avery Dennison SC 900-101-0 White | Avery Dennison SC 900-965-0 Sandstone |

MATERIALS

All materials to be provided as 8" x 8" sample or as part of a mock-up for approval.

| |
|---|
|  |
|  |
| iZone |

NOTES

- 1 Avery Dennison SC 900-101-0 White vinyl lettering applied to painted aluminum panel with clear coat finish
- 2 #5052 min. aluminum alloy grade painted aluminum with clear coat finish
- 3 Color determined by district
Please reference figure 8 and 9
- 4 iZone or custom high pressured laminate (CHPL)
- 5 Avery Dennison SC 900-965-0 Sandstone vinyl lettering applied to painted aluminum panel with clear coat finish
- 6 1' high precast concrete with ornate detailing

SIGN FABRICATION SPECIFICATIONS

All single-sided, aluminum sign to be 1/16" min. #5052 min. aluminum alloy grade.

All double-sided aluminum can signs to be 3/16" min. #5052 min. aluminum alloy grade.

Single-sided sign blanks to have smooth edges and surfaces. Paint all surfaces with three (3) color coats of polyurethane, gloss finish.

Aluminum can signs to be tack welded and filled with bondo. All surfaces to be sanded smooth free of voids, warping or canning. Then sprayed with three coats : 1 coat of filler primer, sand, 1 color coat of sealer primer, sand and 1 color coat of polyurethane, gloss finish.

The sign and pole primer is Calspar Val-Chem Epoxy Primer (13-F-62). The color coating is Valspar V Thane Hi Solids Urethane Enamel (54 series), color to match MP20189 Corinthian Bronze Metallic.

All graphics to be premium grade computer cut white vinyl.

Use only stainless steel fasteners on signs and supports.

Casted brackets and caps must follow general design requirements set forward in **FIGURES 42 & 43**. Fabricator must supply shop drawings and specifications for approval. Casted items must be painted with three (3) coats of polyurethane.

The casted brackets, sign pipes and connections must be engineered for sheer stress and vertical weight prior to fabrication and installation. (**FIGURE 42**) The signs must meet current sign codes for the City of San Diego.

Historical Landmarks

The intent of the Historical Landmarks sign is to identify buildings and sites that are a result of the 1915 & 1935 Expositions held in the park.

The sign can be wall-mount or pole-mount. The park logo will be incorporated into a diamond shape background with the identification of the 1915 Expo or the 1935 Expo. (**FIGURE 26**)

There will be one color for the logos on the dark bronze background:
White (SC 900-101-0)

Banners

Banners located in the Historical Landmark Area should follow as closely as possibly to the banners and standards used in the 1935 Exposition. (**FIGURE 25A**) Banners outside of the Historical Landmark Area may follow banner standards exhibited in **FIGURE 25**.

POLE STANDARDS

The areas designated as a historical landmark will incorporate pole standards reflecting the pole design used in the park during the exposition periods. The signs however will remain true to the park sign guidelines.

The Prado

The pole standards for the Prado shall be compatible with the historical architecture of the 1915 Exposition. The style is Capistrano, manufactured by Western Lighting Standards, a subsidiary of Spring City Lighting or approved equal. The pole standard color for the Prado is a bronze green, Frazee #6125N based on writings of Carlton Monroe Winslow - Architecture & Gardens - San Diego Exposition 1915. For sign attachment possibilities see **FIGURE 43**.

Poles will be 3" and 5" diameter aluminum tubing. Pole wall thickness to be 1/8" min. for the 3" pole, and 3/16" min. for the 5" pole. Pole bracket and footing to be engineered by fabricator. Depending on pole height and loading, anchor bolts may change. Poles to be painted with three (3) color coats of polyurethane.

Sign Pole Color Prado

The sign standards in the Prado area of the park, which include the Capistrano pole, base, brackets, horizontal pipe & the cap will be Frazee Custom Color CZ-12-2935.

Overall

Bases are the Mariner and Mini-Mariner manufactured by Western Lighting Standards, a subsidiary of Spring City Lighting or approved equal. Bases to be anchored to pole/ base footing as per manufacturer's specifications. Bases to be painted with three (3) color coats of polyurethane.

Fabricator is responsible for isolating dissimilar materials to prevent electrolysis.

Sign Pole Color Overall

The color for the sign standards, which include the Mariner and Mini-Mariner pole, base, brackets, horizontal pipe & the cap will be Matthews Paint MP201189 Corinthian Bronze Metallic.

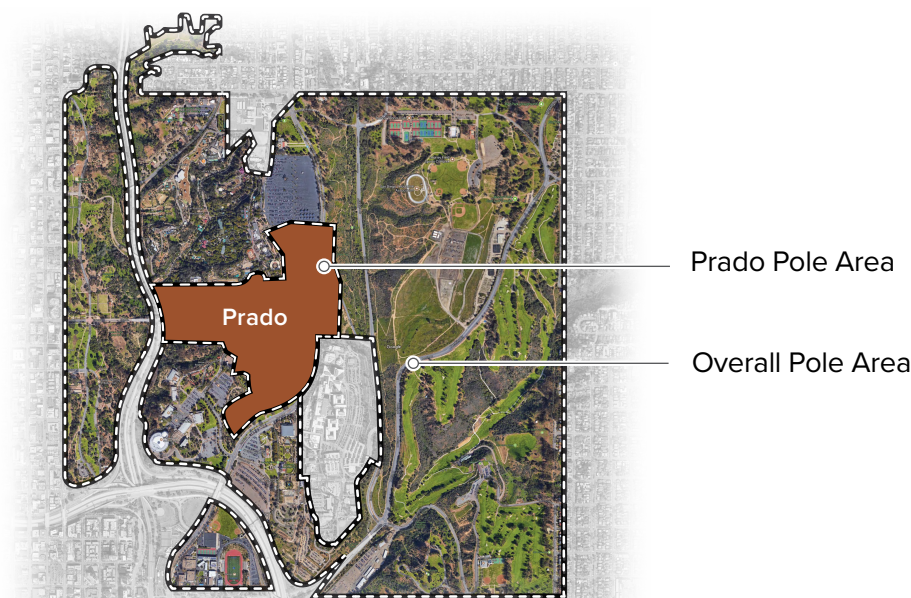

SECTION 2

THE BRAND

FIGURE 1 & 2 LOGO

The following diagrams illustrate the approved logo variations for the signage throughout the park. The white Balboa Park logo without the tag line will be used on most signage throughout the park. The white historical Balboa Park logo will be used on the signs in the historical area of the park.



HISTORICAL LANDMARK AREA LOGO



FIGURE 3 LOGO REGULATIONS

The following diagrams illustrate the approved and disapproved logo variations for the signage throughout the park. The white Balboa Park logo without the tag line will be used on most signage throughout the park. The white historical Balboa Park logo will be used on the signs in the historical area of the park. The colored Balboa Park logo and white Balboa Park logo with the tag line may not be used on any signage.

APPROVED VARIATIONS



White logo on dark bronze



White logo on white for historical signage

DISAPPROVED VARIATIONS

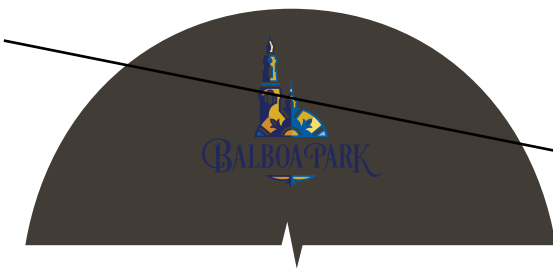

Colored logo on dark bronze



White logo with tag-line on dark bronze

FIGURE 4

BALBOA PARK TYPE STYLE

Christiana

Christiana was designed for Berthold in 1991 by Gudrun Zapf-von Hesse. It's varied stroke weights and angled endings give this typeface an elegant, hand-lettered impression. It is similar in form and inspiration as Optima, but is a bit more humanistic and is easier to read on signage due to its many weights and strokes.

Christiana Regular

All subheadings on location / building signs, Pedestrian Orientation Signs, and Parking Lot Signs. Collateral and printed material body copy.

ABCDEFGHIJKLMNOPQRSTUVWXYZ
abcdefghijklmnopqrstuvwxyz
0123456789

Christiana Italic

To be used for walking times on select sign types as a subhead to the destination on Directional Signs, Pedestrian Orientation Signs, Pedestrian Directory/ Directional signs, and Pedestrian Flag Signage.

ABCDEFGHIJKLMNOPQRSTUVWXYZ
abcdefghijklmnopqrstuvwxyz
0123456789

Christiana Medium

All headings on directional signs, Pedestrian Orientations Signs, Traffic Signs, Parking Lot Signs and Location/Building ID Signs. Headings on all collateral and printed material.

ABCDEFGHIJKLMNOPQRSTUVWXYZ
abcdefghijklmnopqrstuvwxyz
0123456789

FIGURE 5 BALBOA PARK ICONS & ARROWS

The following are the proposed icons and arrows used to identify parking, tram stops, restrooms, wheelchair accessibility and directionals throughout the park on Park maps, vehicular directionals and pedestrian wayfinding signage.

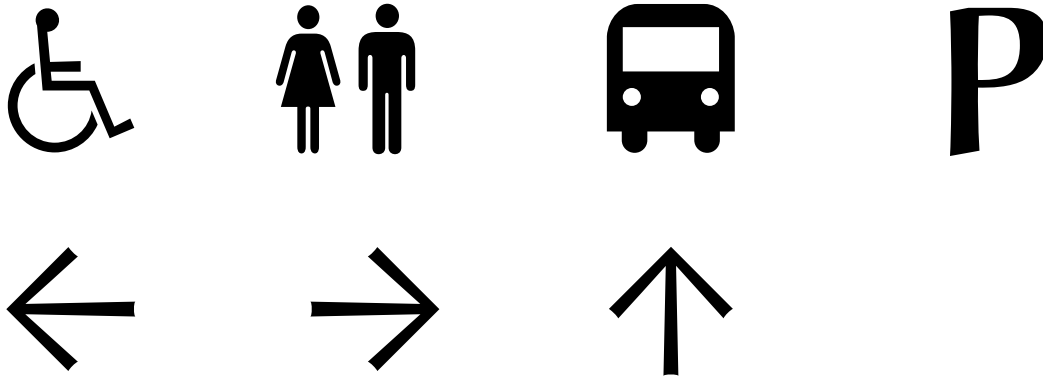

FIGURE 6 BRAND SIGNAGE EXAMPLE

The diagram below illustrates how the Balboa Park logo is placed on the signage throughout the park. The read lines (center line) shows that the logo is centered between the X and Y coordinates.

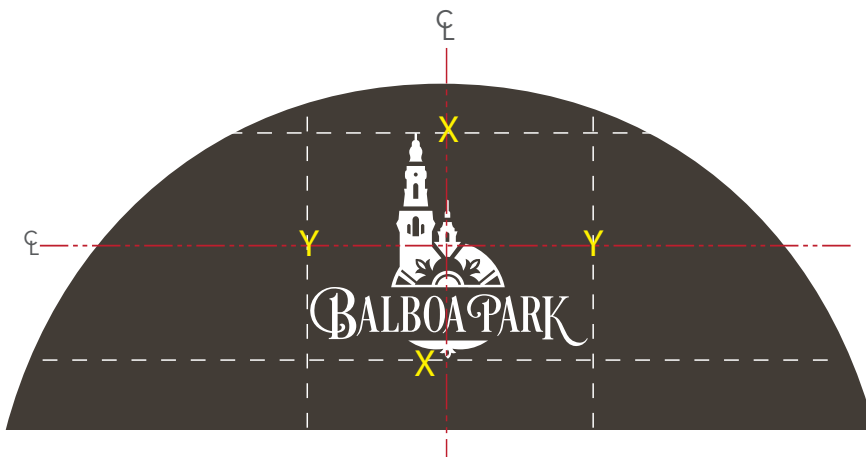
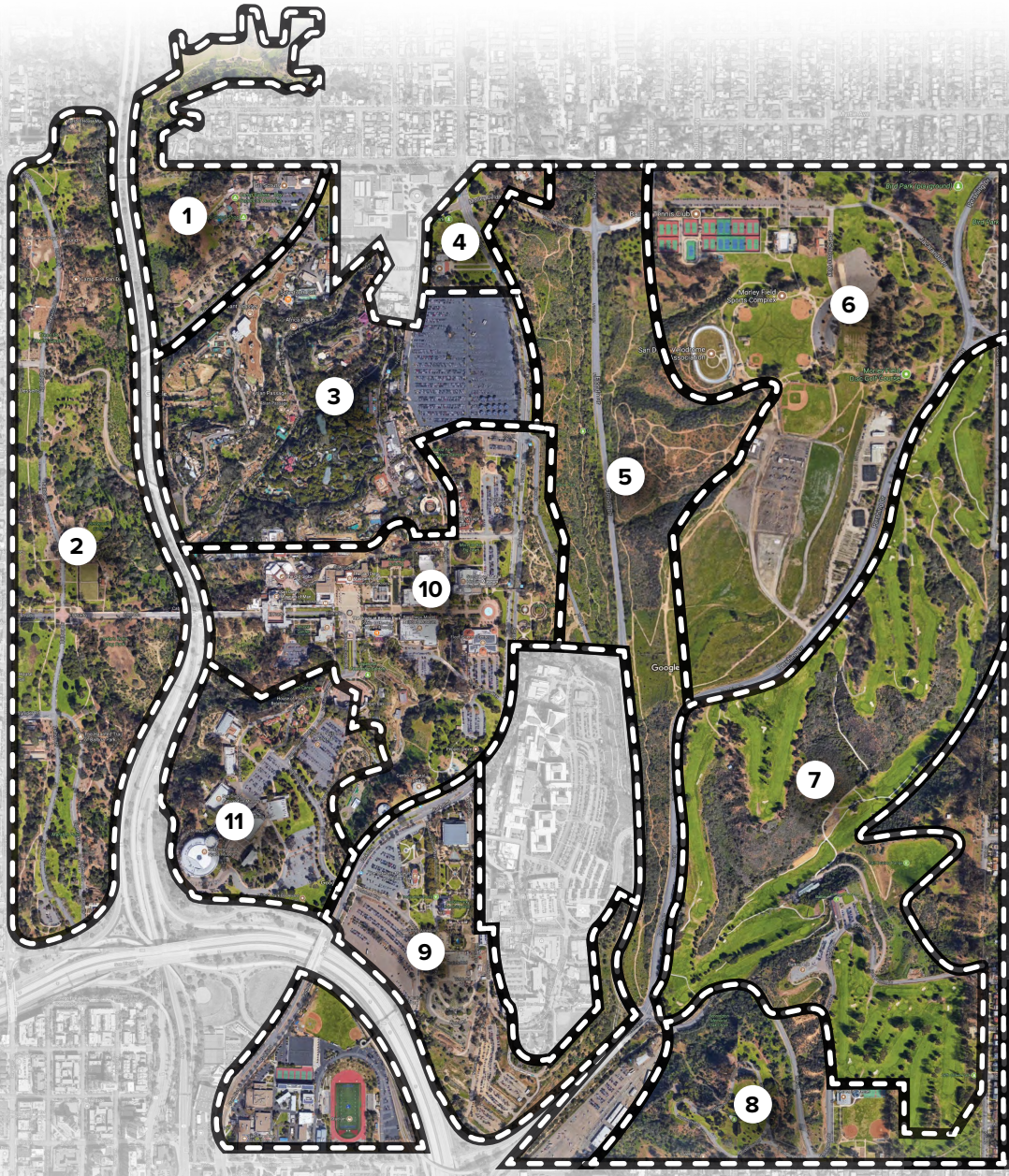

FIGURE 7 DISTRICT MAP

The following is an updated visual per the Parks current conditions today. The districts have not been changed nor modified from the approved Balboa Park Masterplan.



- | | | |
|--|---------------------------|-------------------|
| 1. Scout Camp Area | 5. Florida Canyon | 10. The Prado |
| 2. Sixth Avenue Area recommend naming West Mesa | 6. Morley Field | 11. The Palisades |
| 3. San Diego Zoo | 7. Municipal Golf Courses | |
| 4. War Memorial Area | 8. Golden Hill Area | |
| | 9. Inspiration Point | |

FIGURE 8 DISTRICT COLORS

The following is the proposed specified colors used to identify the various districts throughout the park on Park maps, vehicular directionals and pedestrian wayfinding signage.

Please note : All colors shown are placeholder only and are to be finalized at a later date.



- | | | |
|--|---------------------------|-------------------|
| 1. Scout Camp Area | 5. Florida Canyon | 10. The Prado |
| 2. Sixth Avenue Area recommend naming West Mesa | 6. Morley Field | 11. The Palisades |
| 3. San Diego Zoo | 7. Municipal Golf Courses | |
| 4. War Memorial Area | 8. Golden Hill Area | |
| | 9. Inspiration Point | |

FIGURE 9 DISTRICTS AND COLOR

The following is the proposed specified colors used to identify the various districts throughout the park on Park maps, vehicular directionals and pedestrian wayfinding signage.

Please note : All colors shown are placeholder only and are to be finalized at a later date.



FIGURE 10 PEDESTRIAN DISTRICTS

The following identifies the primary pedestrian districts within the Central Mesa. Because this is where the majority of users will interface within the park it is important to identify sub-districts or areas within the various districts.

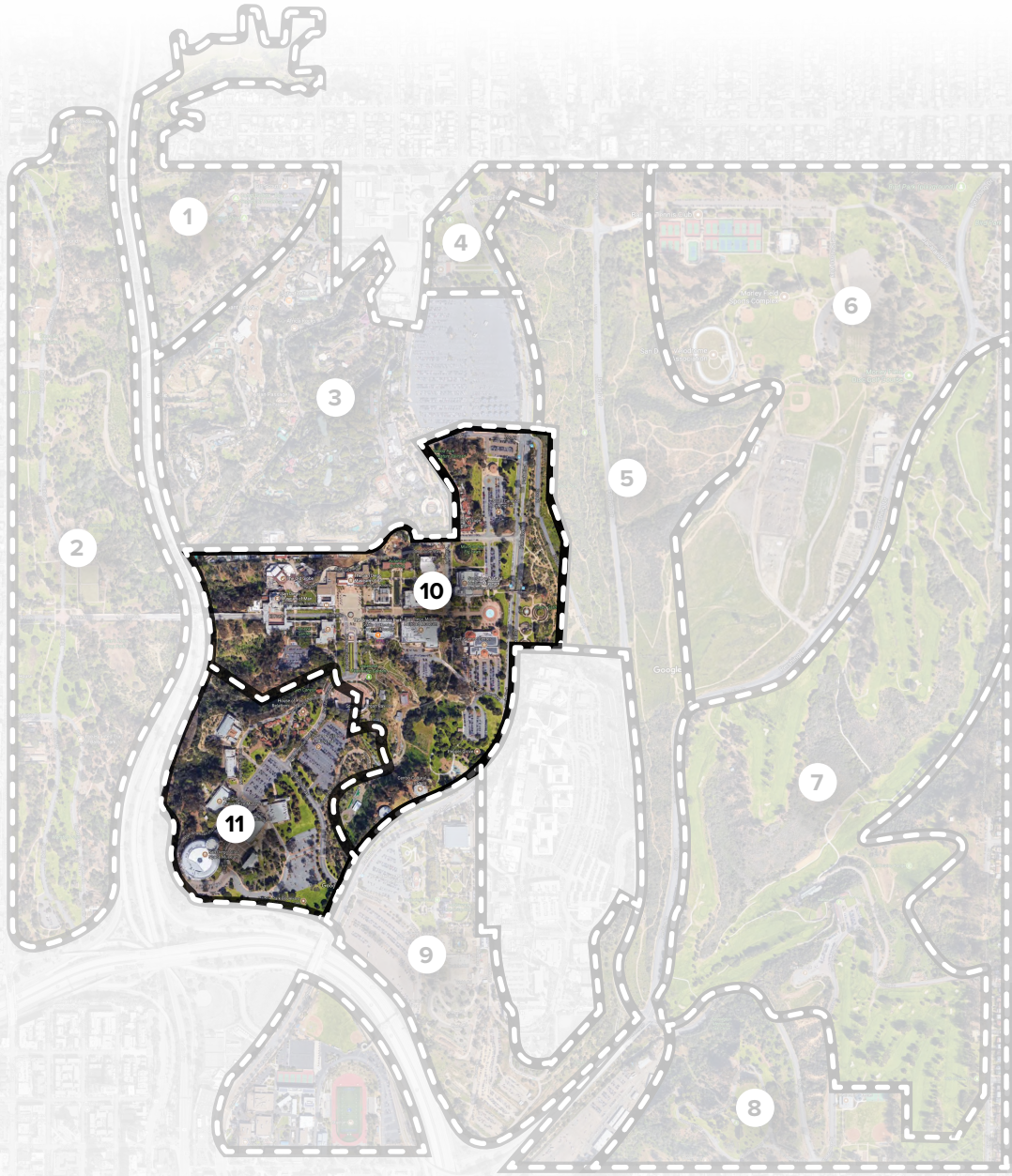

- | | | |
|--|---------------------------|-------------------|
| 1. Scout Camp Area | 5. Florida Canyon | 10. The Prado |
| 2. Sixth Avenue Area recommend naming West Mesa | 6. Morley Field | 11. The Palisades |
| 3. San Diego Zoo | 7. Municipal Golf Courses | |
| 4. War Memorial Area | 8. Golden Hill Area | |
| | 9. Inspiration Point | |

FIGURE 11 THE PRADO

The following illustrates the different areas or potential sub districts within the overall district of The Prado. The intent is to maintain the district color at the bottom and reverse side of the sign, while changing the messaging at the base of the sign panel that identifies the district.

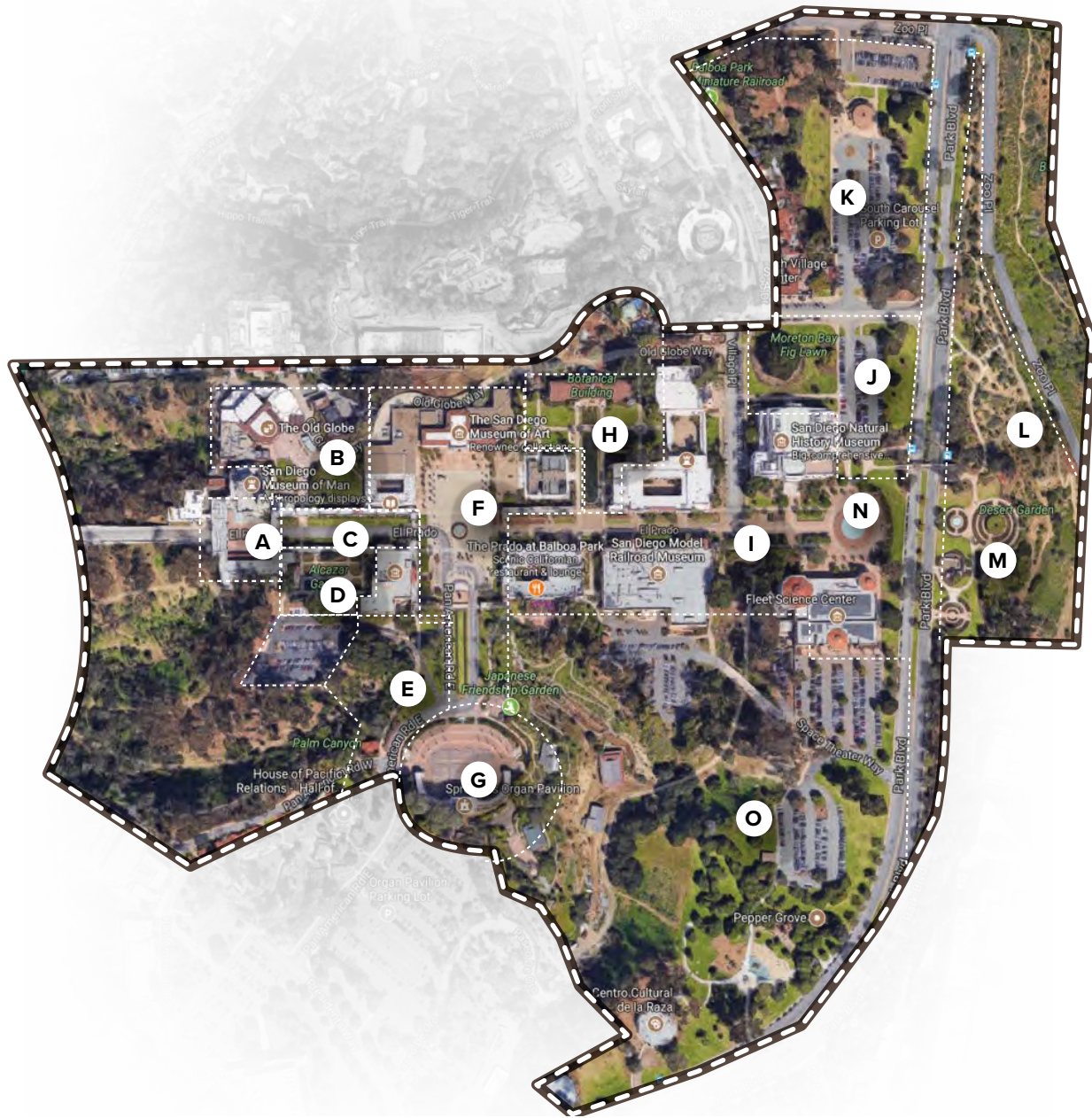

- A : Plaza de California
- B : Old Globe
- C : West Prado
- D : Alcazar Gardens
- E : Palm Canyon

- F : Plaza De Panama
- G : Spreckels Organ Pavilion
- H : Botanical Gardens
- I : East Prado
- J : Moreton Bay Fig Lawn

- K : Spanish Village
- L : Desert Garden
- M : Rose Garden
- N : Plaza De Balboa
- O : Pepper Grove

FIGURE 12 THE PRADO

The following illustrates the different areas or potential sub districts within the overall district of The Prado. The intent is to maintain the district color at the bottom and reverse side of the sign, while changing the messaging at the base of the sign panel that identifies the district.



- A : Plaza de California
- B : Old Globe
- C : West Prado
- D : Alcazar Gardens
- E : Palm Canyon

- F : Plaza De Panama
- G : Spreckels Organ Pavilion
- H : Botanical Gardens
- I : East Prado
- J : Moreton Bay Fig Lawn

- K : Spanish Village
- L : Desert Garden
- M : Rose Garden
- N : Plaza De Balboa
- O : Pepper Grove

FIGURE 13 THE PALISADES

The following illustrates the different areas or potential sub districts within the overall district of The Palisades Area. The intent is to maintain the district color at the bottom and reverse side of the sign, while changing the messaging at the base of the sign panel that identifies the district.



- A : International Cottages**
- B : Pan American Plaza**
- C : Federal Parking Lot**
recommend naming
Presidents Way Parking Lot



FIGURE 14 MAPPING DISTRICTS

The following illustrates the mapping strategy for each highlighted district throughout the park. Panel will include area identification, location description, a macro map graphic, a micro map graphic and a legend. (This mapping strategy is used with the Pedestrian Orientation sign type) Final map to be developed by others.

PLAZA DE PANAMA

Park Map



Lorem ipsum dolor sit amet, consectetur adipiscing elit, sed diam nonummy nibh euismod tincidunt ut laoreet Lorem ipsum dolor sit amet, consectetur adipiscing elit, sed diam nonummy nibh euismod tincidunt ut laoreet dolore magna aliquam erat volutpat. Ut wisi enim ad minim veniam, quis nostrud exerci tation

Lorem ipsum dolor sit amet, consectetur adipiscing elit, sed diam nonummy nibh euismod tincidunt ut laoreet Lorem ipsum dolor sit amet, consectetur adipiscing elit, sed diam nonummy nibh euismod tincidunt ut laoreet dolore magna aliquam erat volutpat. Ut wisi enim ad minim veniam, quis nostrud exerci tation





AREA IDENTIFICATION

Defines where the directory is located, a specific color for each district.

LOCATION DESCRIPTION

The following gives a brief history and description of the location in which the sign is located. Providing both an educational component for the guest as well as beneficial information about the park.

MACRO MAP GRAPHIC

A small version of the entire project.

MICRO MAP GRAPHIC

Shows the zoomed in area of where the directory is located and closely surrounding areas.

LEGEND

To help orient and understand the map with bold icons and graphics.

SECTION 3

SIGNAGE SPECIFICATIONS

FIGURE 15 OFF-SITE DIRECTIONALS

The following sign is to be used off-site within the surrounding neighborhoods to help direct guests to the park from both a vehicular and pedestrian orientation.

NOTES

The following illustrates the off-site directionals used for Balboa Park. Sign made with 60° arch at top and 1-1/2" radius bottom corners. .

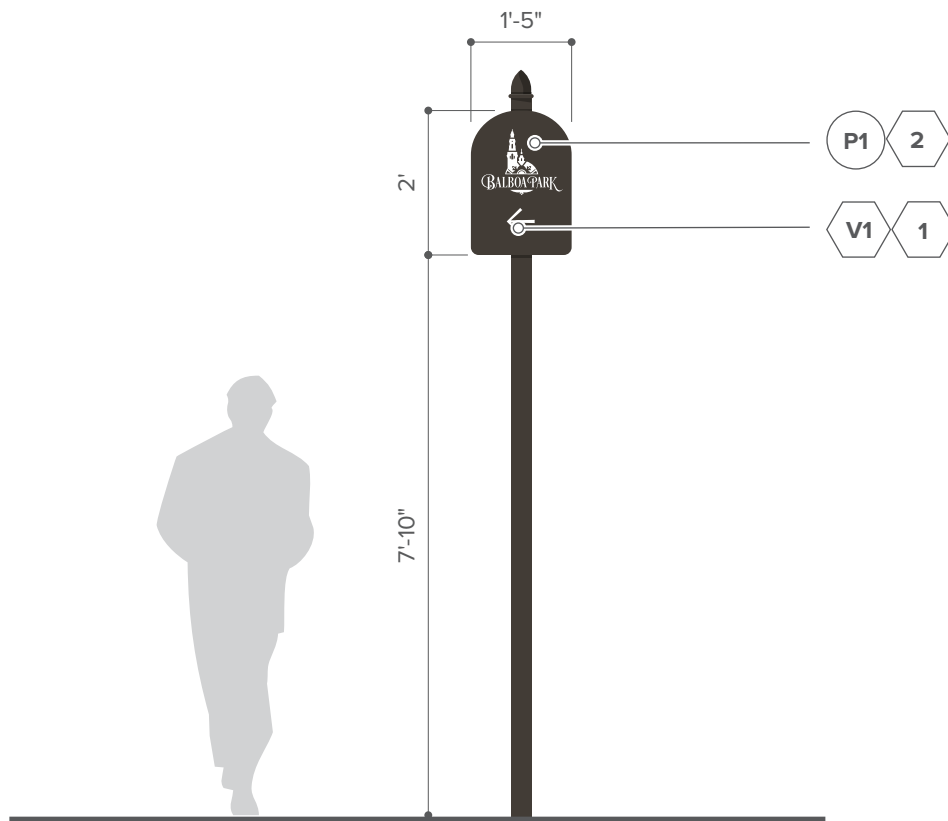

All signage to have below grade concrete foundation engineered by sign fabricator.

1 Front Elevation
Scale : 3/8"=1'

FIGURE 15A OFF-SITE DIRECTIONALS (DETAILS)

The following illustrates the off-site directionals in detail, verifying materials used and measurements for the layout of the sign.

NOTES

The following illustrates the off-site directionals used for Balboa Park.
Sign made with 60° arch at top and 1-1/2" radius bottom corners. .

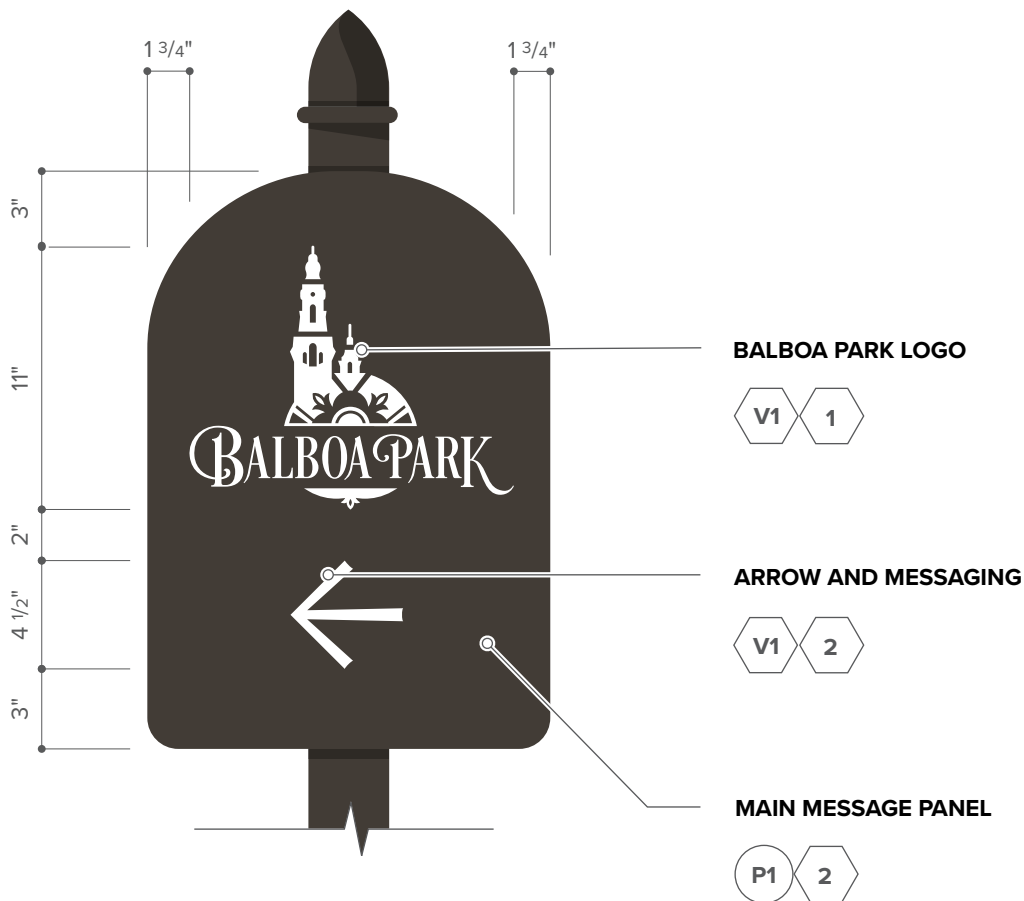

1 Front Elevation
Scale : 1 1/2"=1'

FIGURE 16 TRAM STOP

The following sign is to be used at tram stop destinations to direct guests where to get on and off the tram around the park. Sign can be mounted to existing poles, pavilions and shade structures to help provide clarity to where guests should wait for the tram.

NOTES

The following illustrates the tram stop signage used throughout the park. Sign made with 60° arch at top and 1-1/2" radius bottom corners.

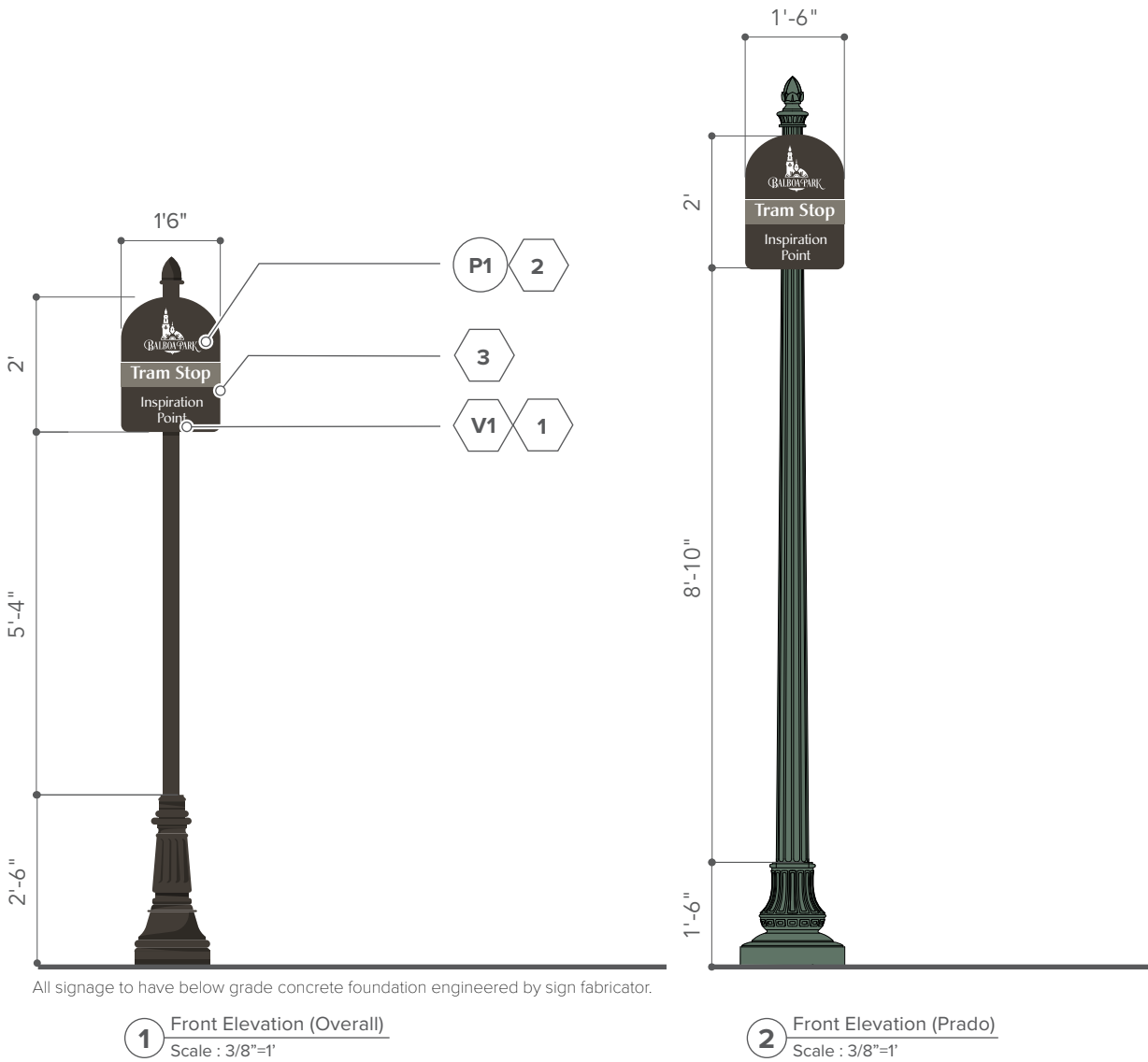

All signage to have below grade concrete foundation engineered by sign fabricator.

FIGURE 16A TRAM STOP (DETAILS)

The following illustrates the tram stop signage in detail, verifying materials used and measurements for the layout of the sign.

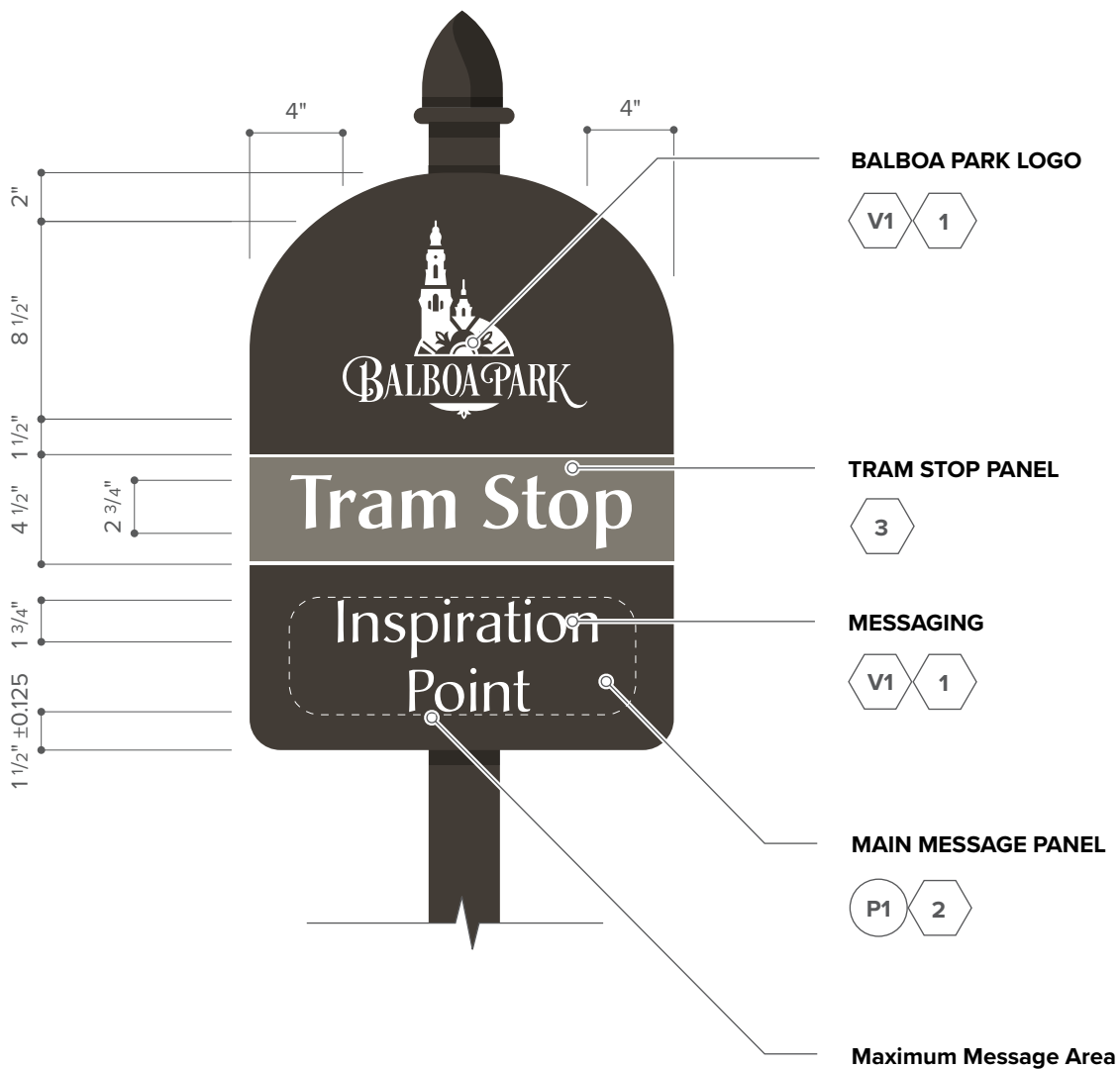

1 Front Elevation
Scale : 1 1/2"=1'

FIGURE 16B

TRAM STOP POLE FOR OVERALL PARK

Mini-Mariner Pole

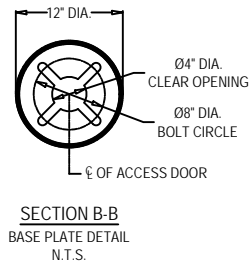
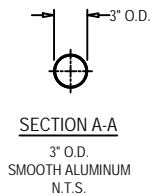
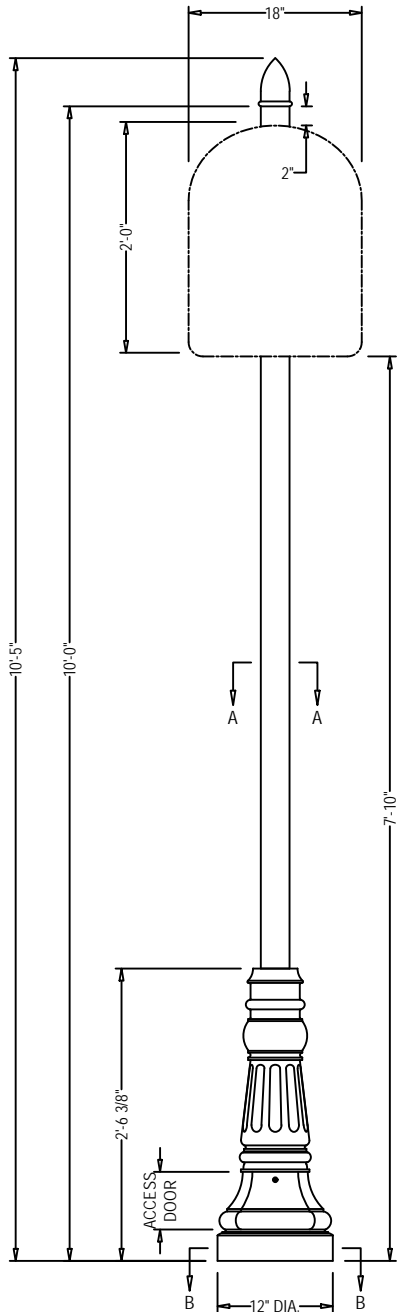

LAMP POST SPECIFICATIONS

STYLE: Mini-Mariner

HEIGHT: 10'-0"

BASE: 12" Diameter

MATERIAL: Shaft - 2 1/2" SCH-40 Aluminum Pipe (3" OD) 6061-T6
Base - Cast Aluminum Alloy A.N.S.I. 356, PER A.S.T.M. B26-95

FINISH: Powder Coat - To match Corinthian Bronze Metallic

ACCESS DOOR: Located in base secured with tamper proof hex socket security machine screws

GROUND PROVISIONS: Drill and tap inside base opposite access door to accommodate a 1/4"-20 ground stud (stud by others)

ANCHOR BOLTS: (4) 3/4" X 17" + 3" hook (fully galvanized with 1 galvanized nut and 1 galvanized washer per bolt)

BOLT PROJECTION: 3" required

CATALOG NUMBER:
Pole - APSMNM-12-10.00-S30-CU
Pole Finial-AFNBLB-3.0-05.00-CU

SPRING CITY ELECTRICAL MFG. CO.
Hall and Main Streets - P.O. Box 19 -
Spring City, PA 19475
PHONE (610) 948-4000
FAX (610) 948-5577
www.springcity.com

DESCRIPTION:
The 10'0" Mini-Mariner with Tram Stop Sign

FIGURE 16C TRAM STOP POLE FOR PRADO AREA

Capistrano Pole

Please note that this pole type will only be used within the Prado area of the park.

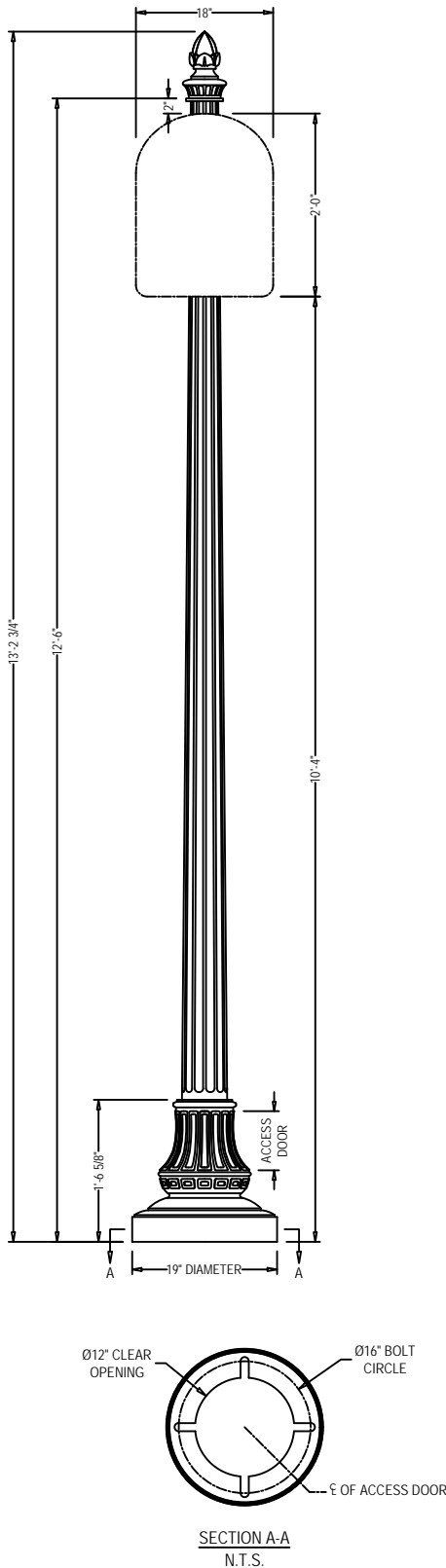

LAMP POST SPECIFICATIONS

STYLE: Capistrano

HEIGHT: 12'-6"

BASE: 19" Diameter

MATERIAL: Cast Aluminum Alloy ANSI 356 Per A.S.T.M. B26-95

FINISH: Powder Coat - To match Frazee Custom Color CZ-12-2935

ACCESS DOOR: Located in base secured with tamper proof hex socket security machine screws

GROUND STUD PROVISIONS: Drill and tap inside wall of base opposite access door to accommodate a 1/4"-20 ground stud (stud by others)

ANCHOR BOLTS: (4) 3/4" X 24" + 3" hook (fully galvanized with 1 galvanized nut and 1 galvanized washer per bolt)

BOLT PROJECTION: 3" required

TENON: 2 7/8" DIA. X 2" High (To Accept Finial)

CATALOG NUMBER:

Shaft - APSCPS-19-12.50-2F-TN2.88/2.00-CU
Pole Finial - AFNWSO-04-08.75-CU

SPRING CITY ELECTRICAL MFG. CO.

Hall and Main Streets - P.O. Box 19 -
Spring City, PA 19475
PHONE (610) 948-4000
FAX (610) 948-5577
www.springcity.com

DESCRIPTION:

The 12'6" Capistrano Aluminum Post with Tram Stop Sign

FIGURE 17

AUTO TRAFFIC DIRECTIONAL

The following sign is to be used to help direct guests to destinations points within the park from a vehicular orientation. The amount of messaging should be limited to a maximum of 5 destinations.

NOTES

The following illustrates the auto traffic directional used throughout the park. District color to wrap around to back of sign only when sign is one-sided. Sign to be 3" thick and manufactured of painted aluminum with a 60° arch top and 1-1/2" radius bottom corners.

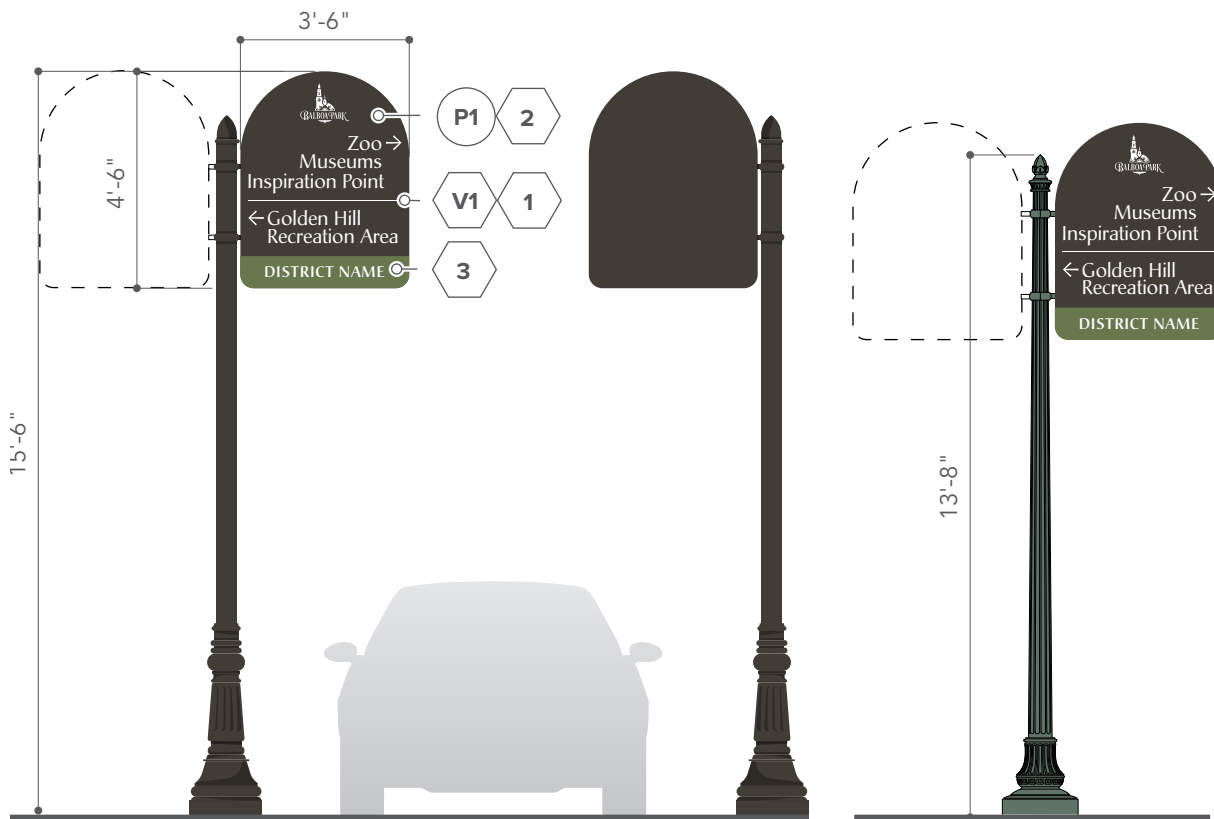

All signage to have below grade concrete foundation engineered by sign fabricator.

1 Front Elevation (Overall)
Scale : 1/2"=1'

2 Back Elevation (Overall)
Scale : 1/2"=1'

3 Back Elevation (Prado)
Scale : 1/2"=1'

FIGURE 17A AUTO TRAFFIC DIRECTIONAL (DETAILS)

The following illustrates the auto traffic directional in detail, verifying materials used and measurements for the layout of the sign.



FIGURE 17B AUTO TRAFFIC DIRECTIONAL (B&W)

The following black and white diagram illustrates the auto traffic directional in further detail, verifying detailed measurements and a maximum messaging area for the layout of the sign. The maximum amount of messaging on this sign is 4.

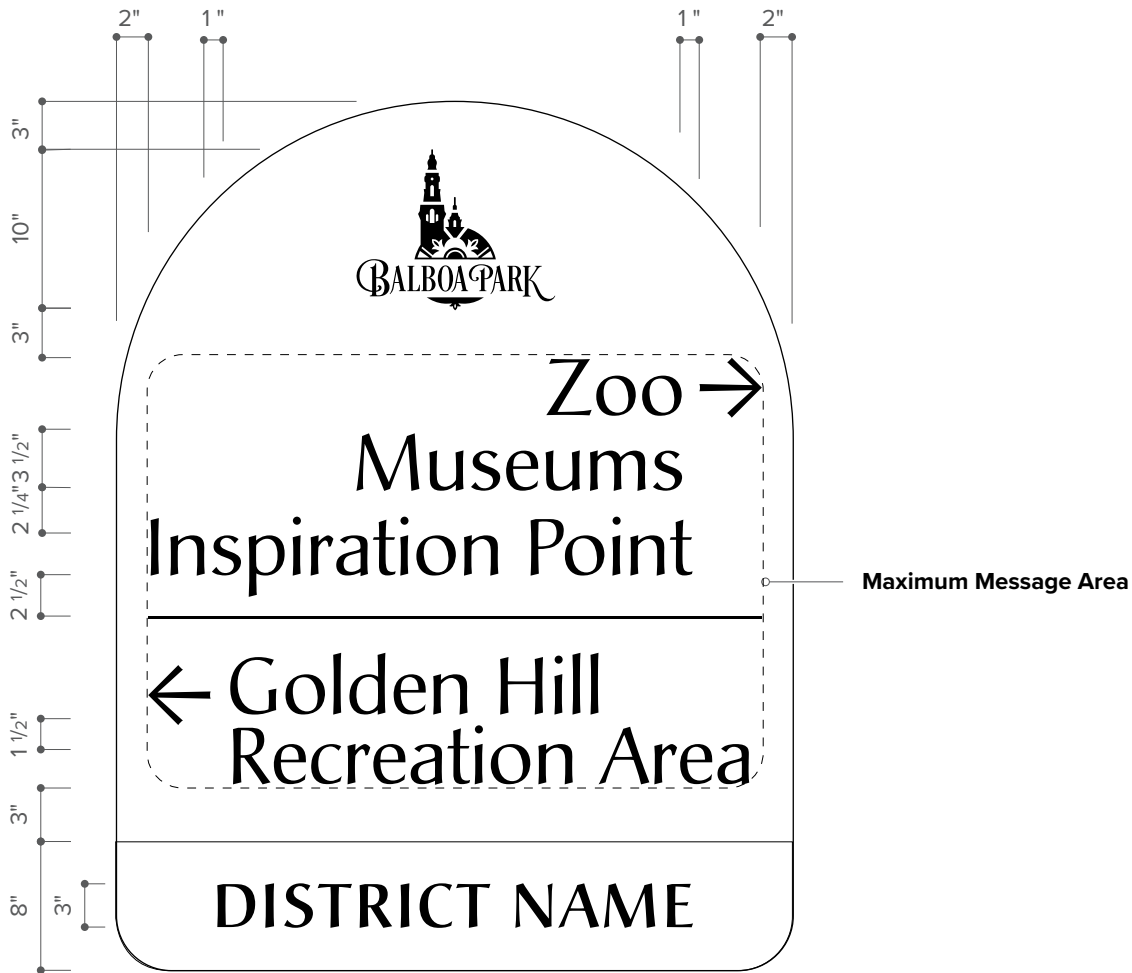

1 Front Elevation
Scale : 1"=1'

FIGURE 17C

AUTO TRAFFIC DIRECTIONAL (B&W)

The following black and white diagram illustrates the auto traffic directional in further detail, verifying detailed measurements and a maximum messaging area for the layout of the sign. This auto traffic directional is 1ft taller to allow for 6 messages instead of 4 on the previous page.

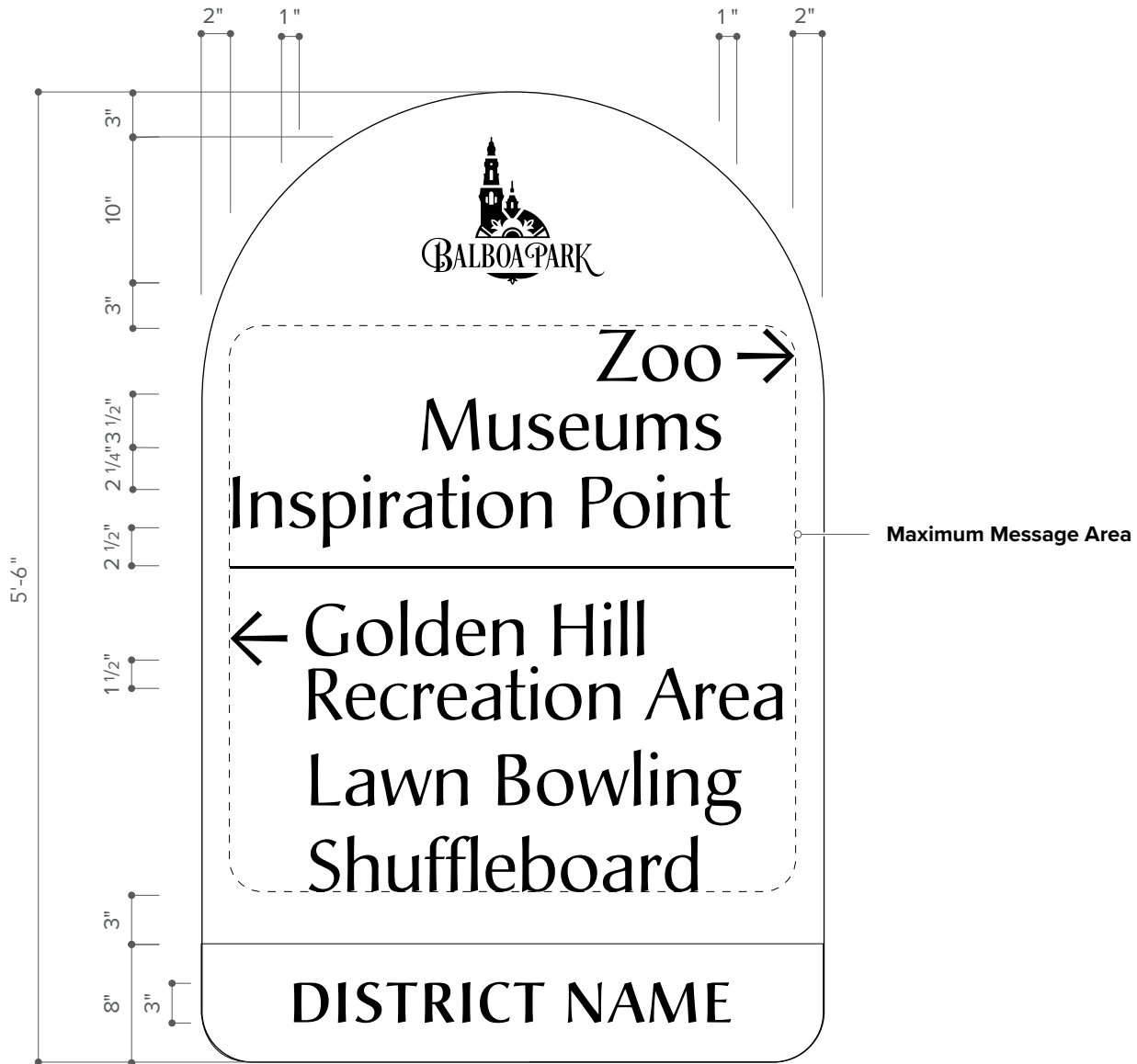

1 Front Elevation
Scale : 1"=1'

FIGURE 17D

AUTO TRAFFIC DIRECTIONAL FOR OVERALL PARK

Mariner Pole

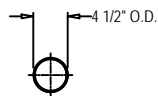
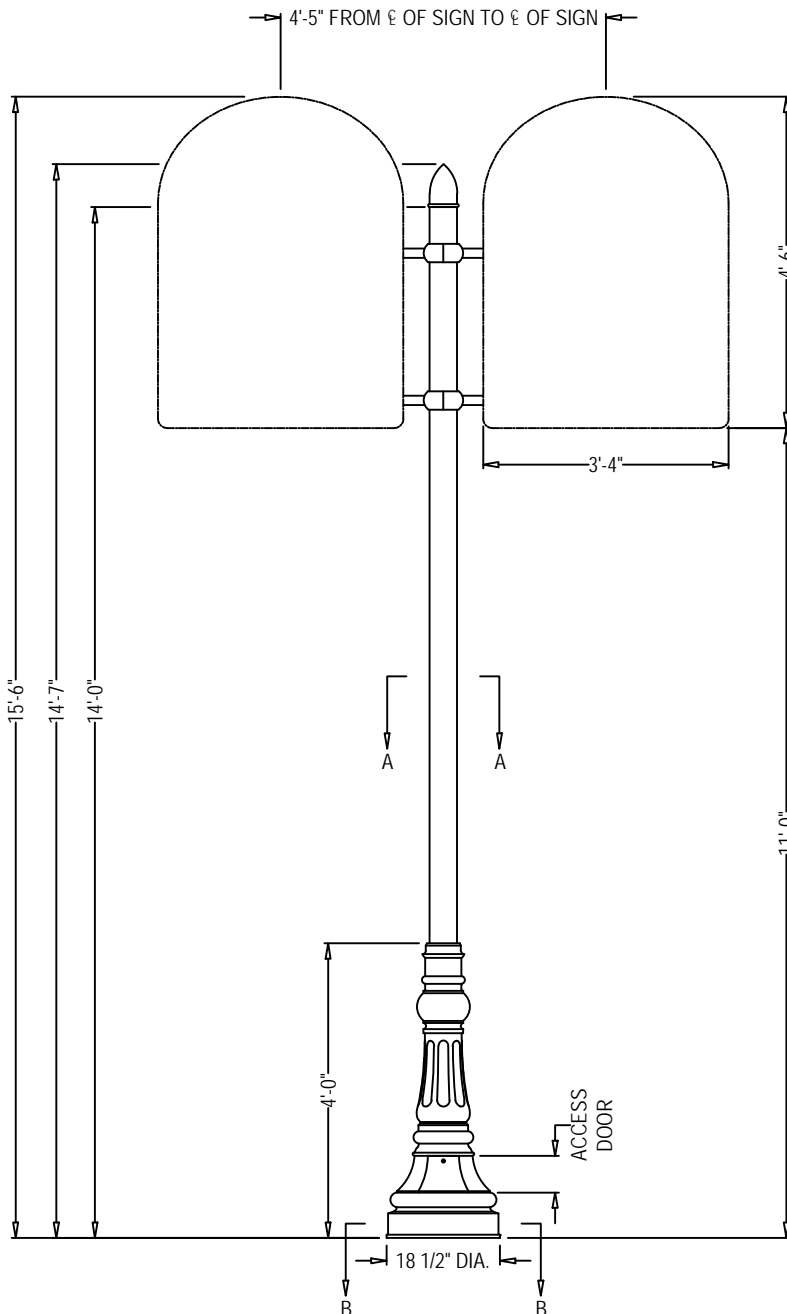

SECTION A-A
4 1/2" O.D.
SMOOTH ALUMINUM
N.T.S.

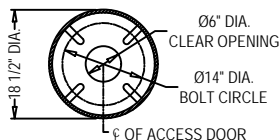

SECTION B-B
BASE PLATE DETAIL

LAMP POST SPECIFICATIONS

STYLE: Mariner

HEIGHT: 14'-0"

MATERIAL: Shaft - 4" SCH-40 Aluminum Pipe (4 1/2" OD) 6061-T6
Base - 1 Piece, Heavy Wall Cast Aluminum Alloy A.N.S.I. 356, PER A.S.T.M. B26-95

FINISH: Powder Coat - To match Corinthian Bronze Metallic

ACCESS DOOR: Located in base secured with tamper proof hex socket security machine screws

GROUND STUD PROVISIONS: Drill and tap inside wall of base opposite access door to accommodate a 1/4"-20 ground stud (stud by others)

ANCHOR BOLTS: (4) 3/4" X 24" + 3" hook (fully galvanized with 1 galvanized nut and 1 galvanized washer per bolt)

BOLT PROJECTION: 3" required

CATALOG NUMBER:
Pole - APSMRN-18-14.00-S45-CU
Pole Finial-AFNBL-4.0-07.00-CU

SPRING CITY ELECTRICAL MFG. CO.
Hall and Main Streets - P.O. Box 19 -
Spring City, PA 19475
PHONE (610) 948-4000
FAX (610) 948-5577
www.springcity.com

DESCRIPTION:
The 14'-0" Mariner with Auto Traffic Directional Signs

FIGURE 17E AUTO TRAFFIC DIRECTIONAL FOR PRADO AREA

Capistrano Pole

Please note that this pole type will only be used within the Prado area of the park.

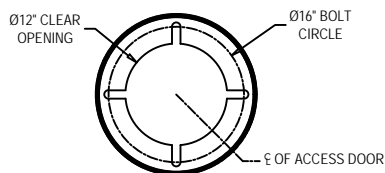
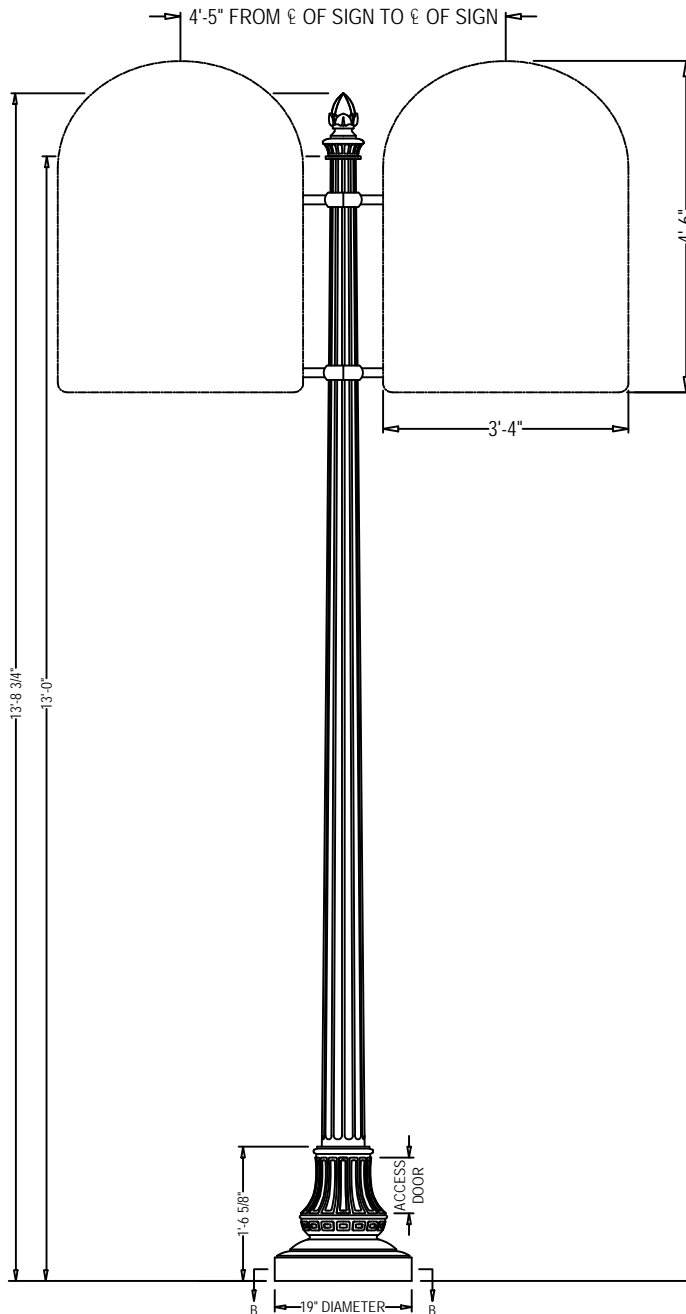

LAMP POST SPECIFICATIONS

STYLE: Capistrano

HEIGHT: 13'-0"

BASE: 19" Diameter

MATERIAL: Cast Aluminum Alloy ANSI 356 Per A.S.T.M. B26-95

FINISH: Powder Coat - To match Frazee Custom Color CZ-12-2935

ACCESS DOOR: Located in base secured with tamper proof hex socket security machine screws

GROUND STUD PROVISIONS: Drill and tap inside wall of base opposite access door to accommodate a 1/4"-20 ground stud (stud by others)

ANCHOR BOLTS: (4) 3/4" X 24" + 3" hook (fully galvanized with 1 galvanized nut and 1 galvanized washer per bolt)

BOLT PROJECTION: 3" required

TENON: 2 7/8" DIA. X 2" High (To Accept Finial)

CATALOG NUMBER:

Shaft -
APSCPS-19-12.50-2F-TN2.88/2.00-CU
Pole Finial - AFNWSO-04-08.75-CU

SPRING CITY ELECTRICAL MFG. CO.

Hall and Main Streets - P.O. Box 19 -
Spring City, PA 19475
PHONE (610) 948-4000
FAX (610) 948-5577
www.springcity.com

DESCRIPTION:

The 13'-0" Capistrano Aluminum Post with Auto Traffic Directional

FIGURE 18 AUTO TRAFFIC SIGNS

The following signs are to be used to direct guests where to park and to orient themselves within the parking lots throughout the park.

NOTES

The following illustrates the auto traffic signage used throughout the park.
Sign to be 3" thick and manufactured of painted aluminum.

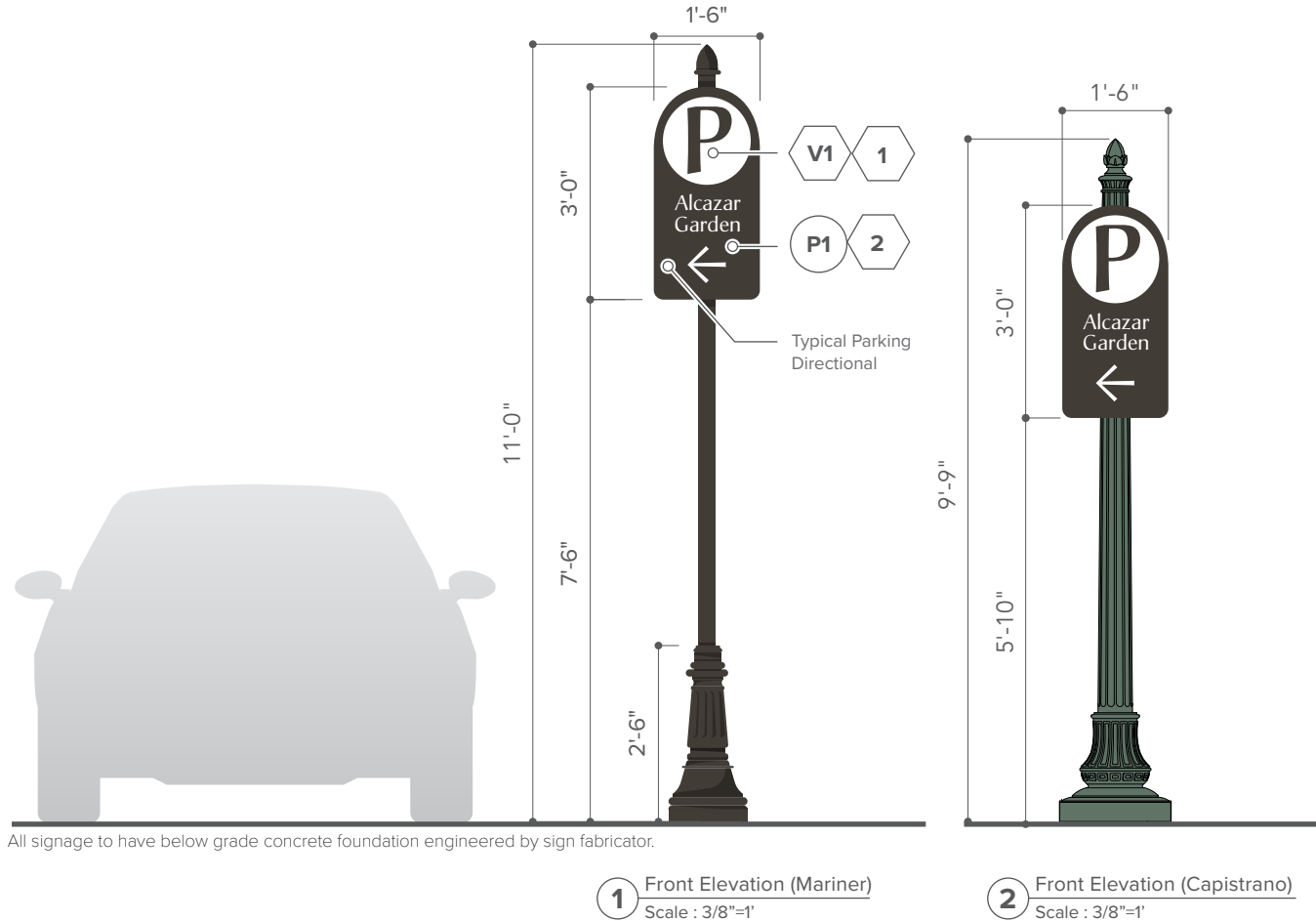

All signage to have below grade concrete foundation engineered by sign fabricator.

FIGURE 18A AUTO TRAFFIC SIGNS (DETAILS)

The following illustrates the auto traffic signage in detail, verifying materials used and measurements for the layout of the sign.

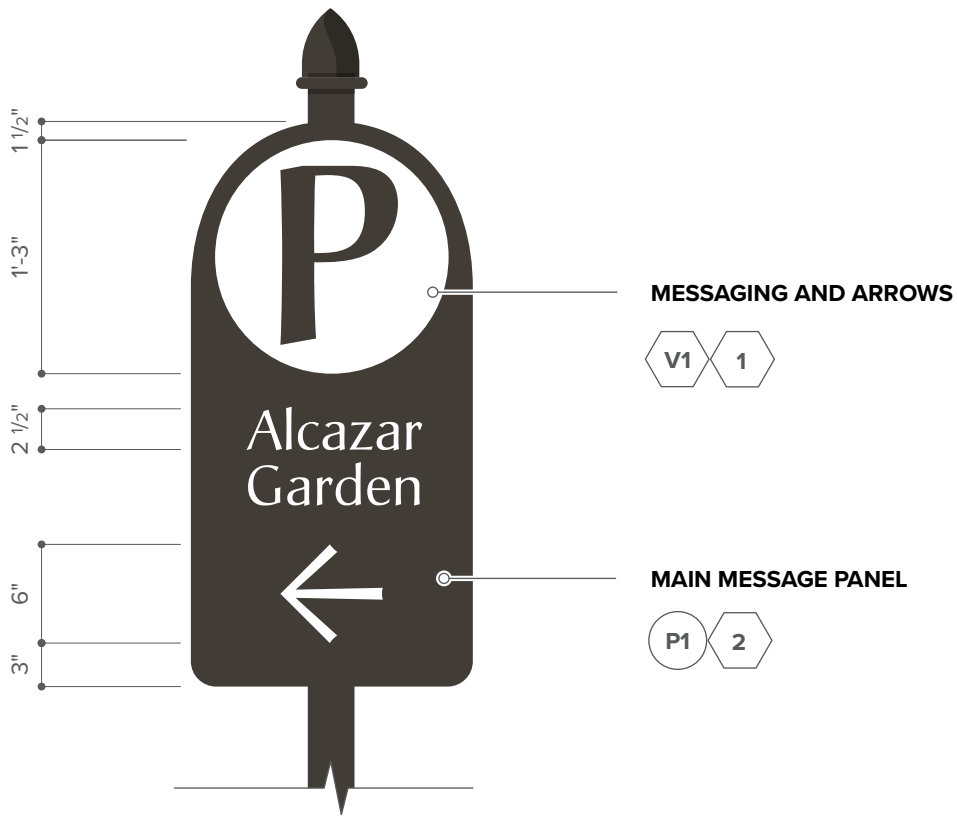

1 Front Elevation
Scale : 1"=1'

FIGURE 18B

AUTO TRAFFIC POLE FOR OVERALL PARK

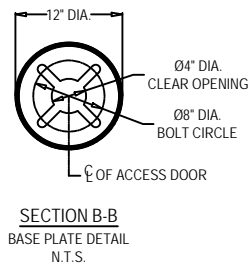
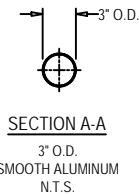
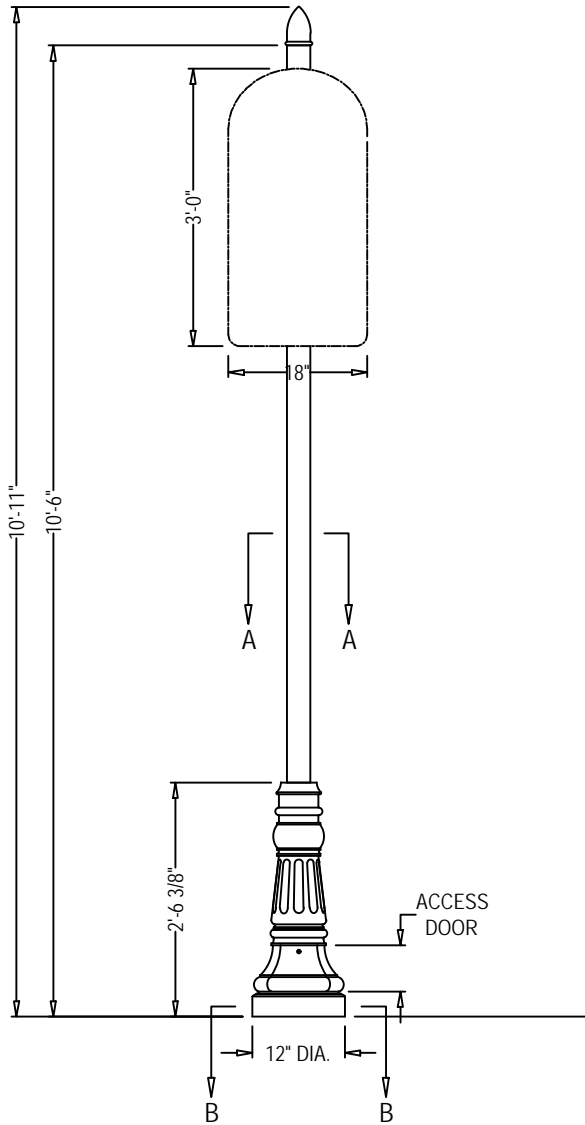

LAMP POST SPECIFICATIONS

STYLE: Mini-Mariner

HEIGHT: 10'6"

BASE: 12" Diameter

MATERIAL:

Shaft - 2 1/2" SCH-40 Aluminum Pipe (3" OD) 6061-T6

Base - Cast Aluminum Alloy A.N.S.I. 356, PER A.S.T.M. B26-95

FINISH: Powder Coat - To match Corinthian Bronze Metallic

ACCESS DOOR: Located in base secured with tamper proof hex socket security machine screws

GROUND PROVISIONS: Drill and tap inside base opposite access door to accommodate a 1/4"-20 ground stud (stud by others)

ANCHOR BOLTS: (4) 3/4" X 17" + 3" hook (fully galvanized with 1 galvanized nut and 1 galvanized washer per bolt)

BOLT PROJECTION: 3" required

CATALOG NUMBER:

Pole - APSMNM-12-07.00-S30-CU

Pole Finial - AFNBLB-3.0-05.00-CU

SPRING CITY ELECTRICAL MFG. CO.

Hall and Main Streets - P.O. Box 19 -

Spring City, PA 19475

PHONE (610) 948-4000

FAX (610) 948-5577

www.springcity.com

DESCRIPTION:

The Mini-Mariner with Auto Traffic Signs

FIGURE 18C

AUTO TRAFFIC POLE FOR PRADO AREA

Capistrano Pole

Please note that this pole type will only be used within the Prado area of the park.

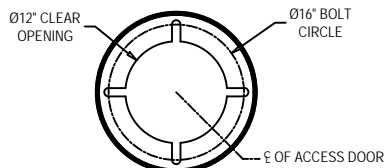
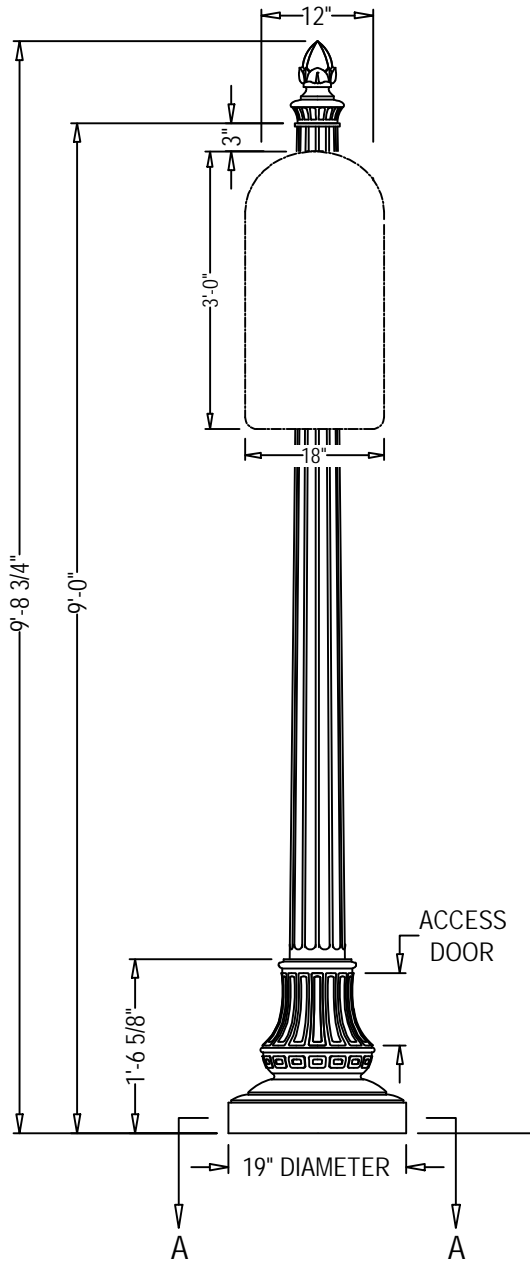

LAMP POST SPECIFICATIONS

STYLE: Capistrano

HEIGHT: 9'-0"

BASE: 19" Diameter

MATERIAL: Cast Aluminum Alloy ANSI 356 Per A.S.T.M. B26-95

FINISH: Powder Coat - To match Frazee Custom Color CZ-12-2935

ACCESS DOOR: Located in base secured with tamper proof hex socket security machine screws

GROUND STUD PROVISIONS: Drill and tap inside wall of base opposite access door to accommodate a 1/4"-20 ground stud (stud by others)

ANCHOR BOLTS: (4) 3/4" X 24" + 3" hook (fully galvanized with 1 galvanized nut and 1 galvanized washer per bolt)

BOLT PROJECTION: 3" required

TENON: 2 7/8" DIA. X 2" High (To Accept Finial)

CATALOG NUMBER:

Shaft - APSCPS-19-12.50-2F-TN.2.88/2.00-CU
Pole Finial - AFNWSO-04-08.75-CU

SPRING CITY ELECTRICAL MFG. CO.

Hall and Main Streets - P.O. Box 19 -
Spring City, PA 19475
PHONE (610) 948-4000
FAX (610) 948-5577
www.springcity.com

DESCRIPTION:

The Capistrano Aluminum Post with Auto Traffic Signs

FIGURE 19 PEDESTRIAN ORIENTATION

The following sign is to be used to help direct guests throughout the park by providing detailed information within specific districts through the use of a macro and micro map, highlighting what is within the guests current location, as well as its place within the overall park.

NOTES

The following illustrates the pedestrian orientation signage used for throughout the park. Sign to be 3" thick and manufactured of painted aluminum with a 60° arch top and 1-1/2" radius bottom corners.

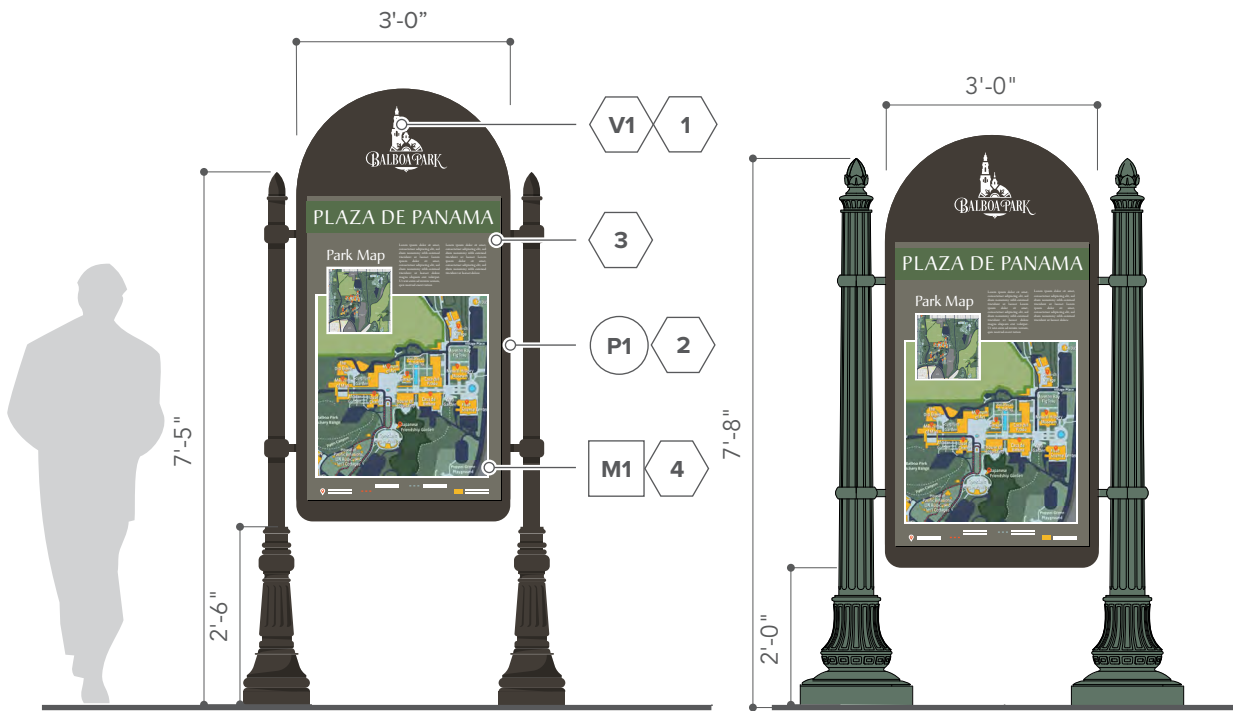

All signage to have below grade concrete foundation engineered by sign fabricator.

① Front Elevation (Overall)
Scale : 3/8"=1'

② Front Elevation (Prado)
Scale : 3/8"=1'

FIGURE 19A PEDESTRIAN ORIENTATION (DETAILS)

The following illustrates the pedestrian orientation signage in detail, verifying materials used and measurements for the layout of the sign.

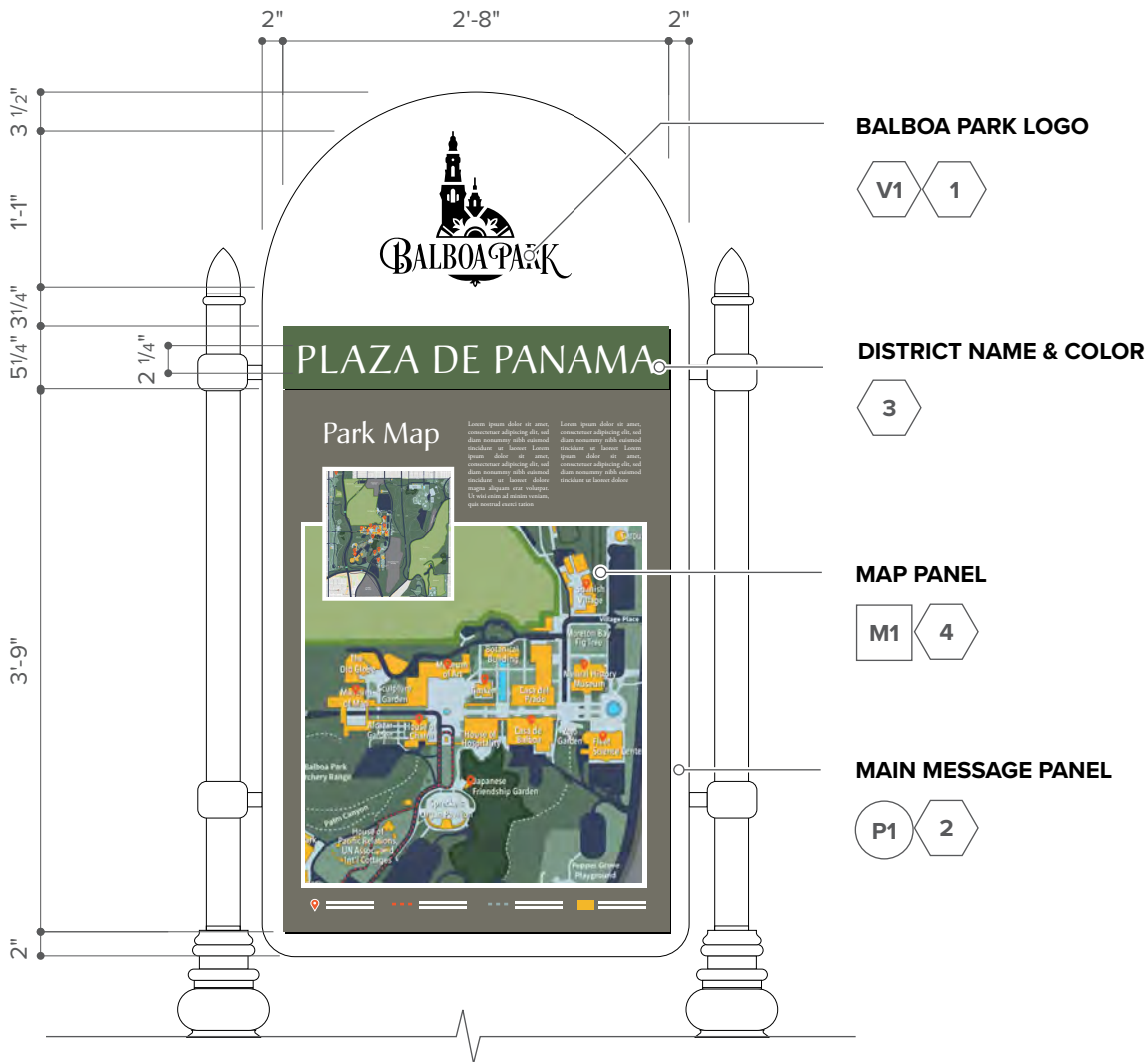

1 Front Elevation
Scale : 3/4"=1'

FIGURE 19B PEDESTRIAN ORIENTATION POLE FOR OVERALL PARK

Mini-Mariner Pole

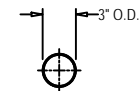
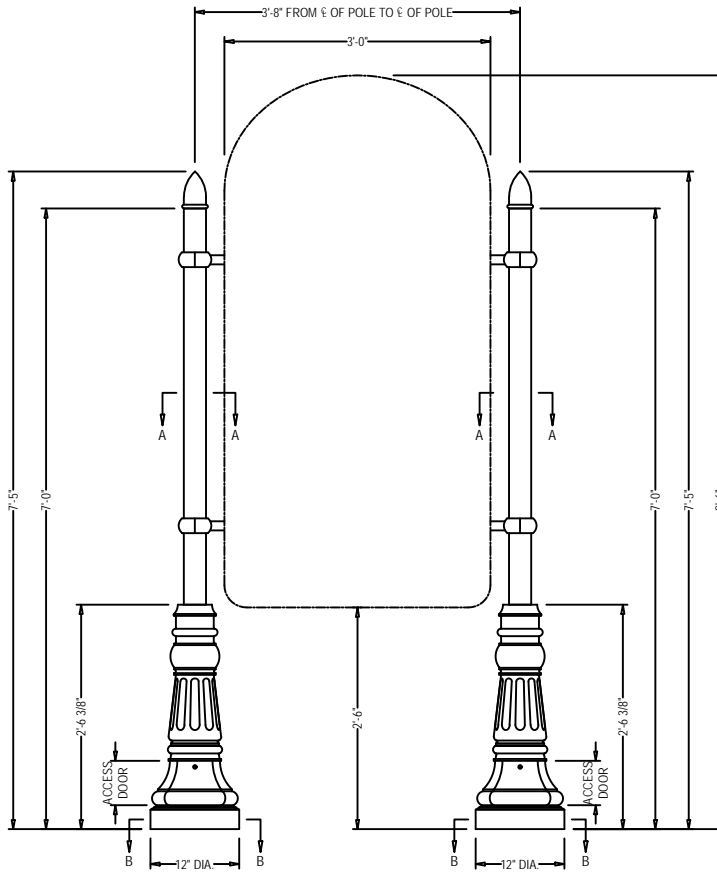

SECTION A-A
3" O.D.
SMOOTH ALUMINUM
N.T.S.

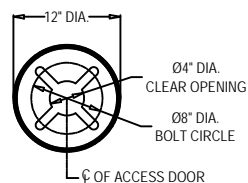

SECTION B-B
BASE PLATE DETAIL
N.T.S.

LAMP POST SPECIFICATIONS

STYLE: Mini-Mariner

HEIGHT: 7'0"

BASE: 12" Diameter

MATERIAL: Shaft - 2 1/2" SCH-40 Aluminum Pipe (3" OD) 6061-T6
Base - Cast Aluminum Alloy A.N.S.I. 356, PER A.S.T.M. B26-95

FINISH: Powder Coat - To match Corinthian Bronze Metallic

ACCESS DOOR: Located in base secured with tamper proof hex socket security machine screws

GROUND PROVISIONS: Drill and tap inside base opposite access door to accommodate a 1/4"-20 ground stud (stud by others)

ANCHOR BOLTS: (4) 3/4" X 17" + 3" hook (fully galvanized with 1 galvanized nut and 1 galvanized washer per bolt)

BOLT PROJECTION: 3" required

CATALOG NUMBER:

Pole - APSMNM-12-07.00-S30-CU
Pole Finial - AFNBLB-3.0-05.00-CU

SPRING CITY ELECTRICAL MFG. CO.

Hall and Main Streets - P.O. Box 19 -
Spring City, PA 19475
PHONE (610) 948-4000
FAX (610) 948-5577
www.springcity.com

DESCRIPTION:

The 7'0" Mini-Mariner with Pedestrian Orientation Sign

FIGURE 19C

PEDESTRIAN ORIENTATION POLE FOR PRADO AREA

Capistrano Pole

Please note that this pole type will only be used within the Prado area of the park.

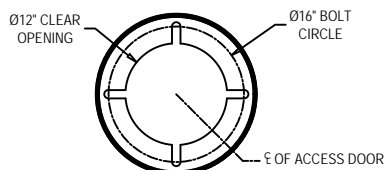
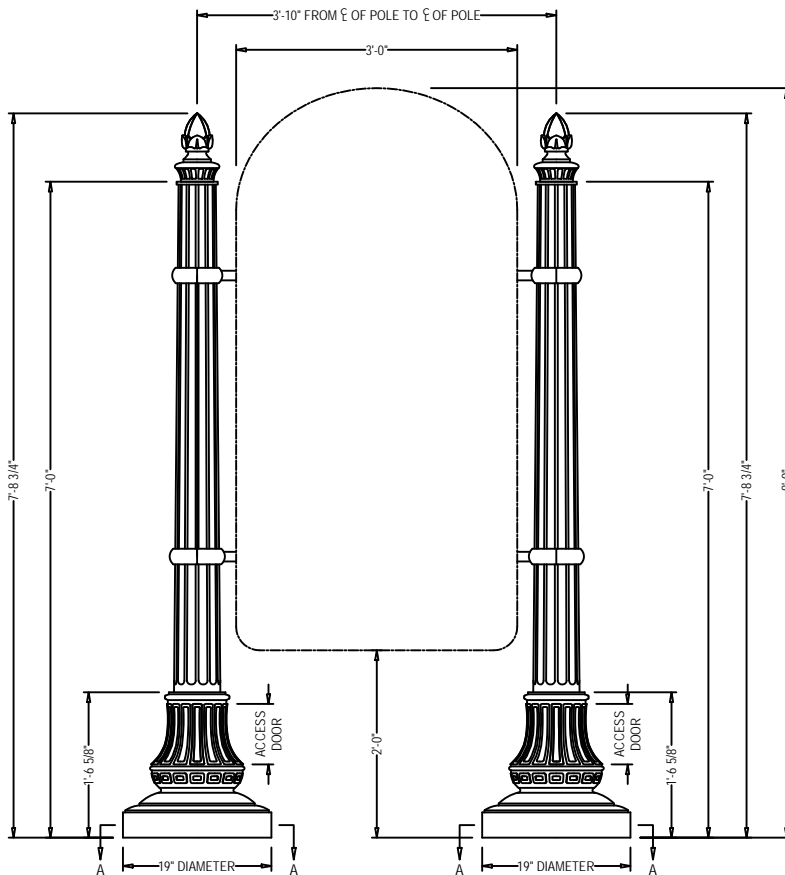

SECTION A-A
N.T.S.

LAMP POST SPECIFICATIONS

STYLE: Capistrano

HEIGHT: 7'-0"

BASE: 19" Diameter

MATERIAL: Cast Aluminum Alloy ANSI 356 Per A.S.T.M. B26-95

FINISH: Powder Coat - To match Frazee Custom Color CZ-12-2935

ACCESS DOOR: Located in base secured with tamper proof hex socket security machine screws

GROUND STUD PROVISIONS: Drill and tap inside wall of base opposite access door to accommodate a 1/4"-20 ground stud (stud by others)

ANCHOR BOLTS: (4) 3/4" X 24" + 3" hook (fully galvanized with 1 galvanized nut and 1 galvanized washer per bolt)

BOLT PROJECTION: 3" required

TENON: 2 7/8" DIA. X 2" High (To Accept Finial)

CATALOG NUMBER:

Shaft - APSCPS-19-12.50-2F-TN2.88/2.00-CU
Pole Finial - AFNWSO-04-08.75-CU

SPRING CITY ELECTRICAL MFG. CO.

Hall and Main Streets - P.O. Box 19 - Spring City, PA 19475
PHONE (610) 948-4000
FAX (610) 948-5577
www.springcity.com

DESCRIPTION:

The 7'0" Capistrano Aluminum Post with Pedestrian Orientation Sign

FIGURE 20 PEDESTRIAN DIRECTIONAL

The following sign is to be used to help direct guests to destinations points within the park from a pedestrian orientation.

NOTES

The following illustrates the pedestrian directional used throughout the park. District color to wrap around to back of sign. Sign to be 3" thick and manufactured of painted aluminum with a 60° arch top and 1-1/2" radius bottom corners.



All signage to have below grade concrete foundation engineered by sign fabricator.

1 Front Elevation (Overall)
Scale : 3/8"=1'

2 Back Elevation (Overall)
Scale : 3/8"=1'

3 Front Elevation (Prado)
Scale : 3/8"=1'

FIGURE 20A PEDESTRIAN DIRECTIONALS (DETAILS)

The following illustrates the pedestrian directional in detail, verifying materials used and measurements for the layout of the sign.

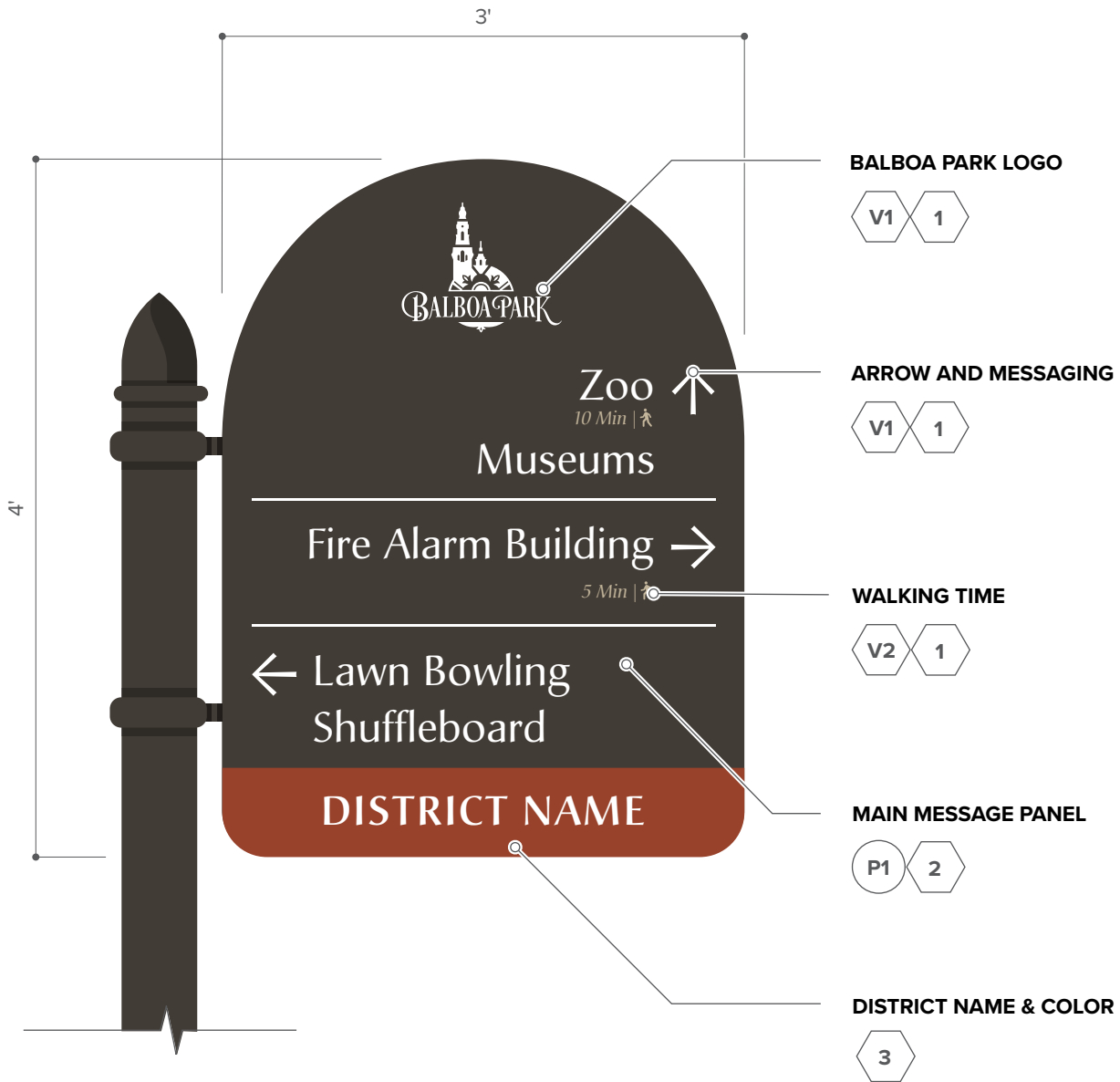

1 Front Elevation
Scale : 1"=1'

FIGURE 20B PEDESTRIAN DIRECTIONAL (B&W)

The following black and white diagram illustrates the pedestrian directional in further detail, verifying detailed measurements and a maximum messaging area for the layout of the sign.

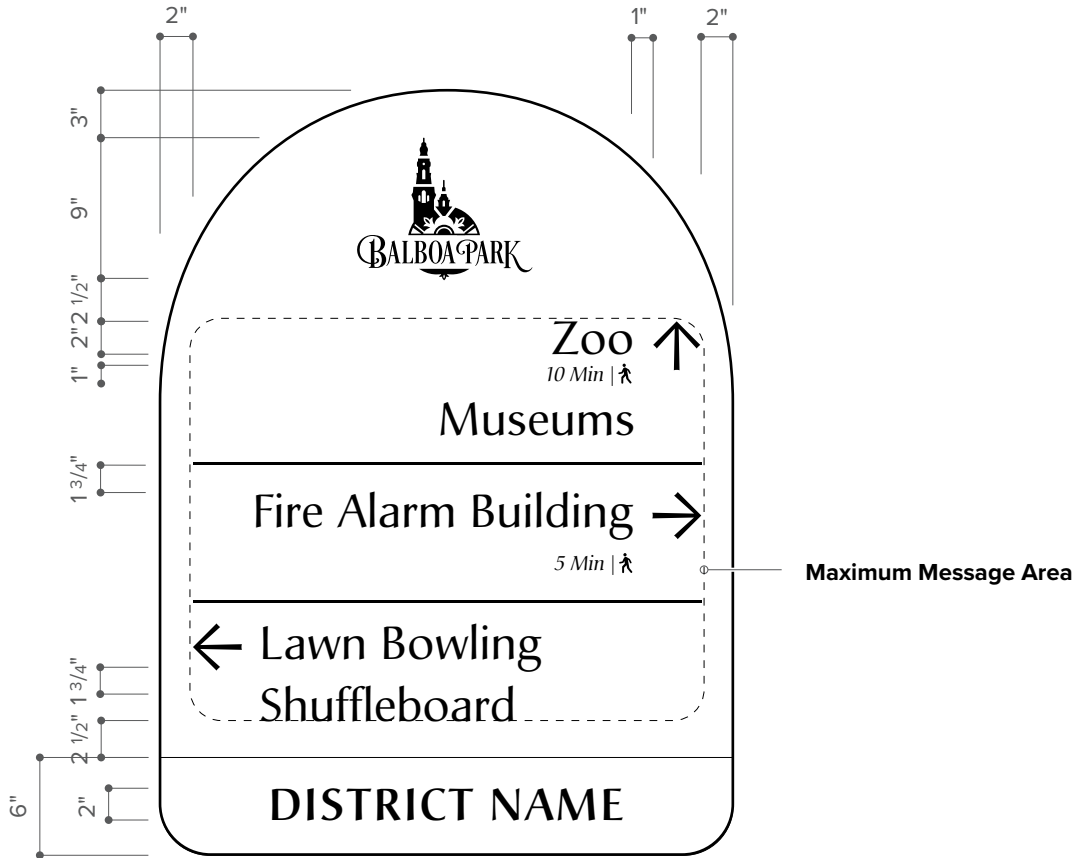

1 Front Elevation
Scale : 1"=1'

FIGURE 20C PEDESTRIAN DIRECTIONAL POLE FOR OVERALL PARK

Mini-Mariner Pole

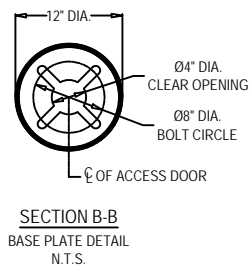
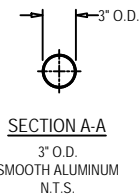
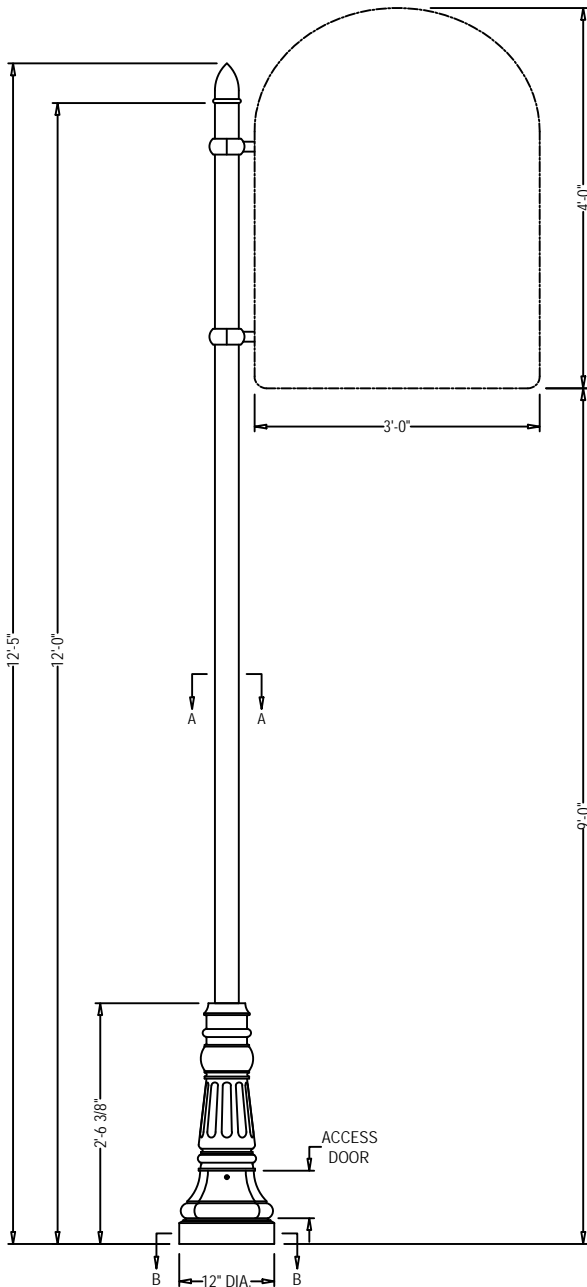

LAMP POST SPECIFICATIONS

STYLE: Mini-Mariner

HEIGHT: 12'0"

BASE: 12" Diameter

MATERIAL: Shaft - 2 1/2" SCH-40 Aluminum Pipe (3" OD) 6061-T6
Base - Cast Aluminum Alloy A.N.S.I. 356, PER A.S.T.M. B26-95

FINISH: Powder Coat - To match Corinthian Bronze Metallic

ACCESS DOOR: Located in base secured with tamper proof hex socket security machine screws

GROUND PROVISIONS: Drill and tap inside base opposite access door to accommodate a 1/4"-20 ground stud (stud by others)

ANCHOR BOLTS: (4) 3/4" X 17" + 3" hook (fully galvanized with 1 galvanized nut and 1 galvanized washer per bolt)

BOLT PROJECTION: 3" required

CATALOG NUMBER:
Pole - APSMNM-12-07.00-S30-CU
Pole Finial - AFNBLB-3.0-05.00-CU

SPRING CITY ELECTRICAL MFG. CO.
Hall and Main Streets - P.O. Box 19 -
Spring City, PA 19475
PHONE (610) 948-4000
FAX (610) 948-5577
www.springcity.com

DESCRIPTION:
The 12'0" Mini-Mariner with Pedestrian Directionals

FIGURE 20D

PEDESTRIAN DIRECTIONAL FOR PRADO AREA

Capistrano Pole

Please note that this pole type will only be used within the Prado area of the park.

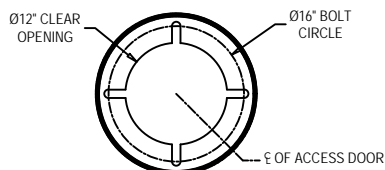
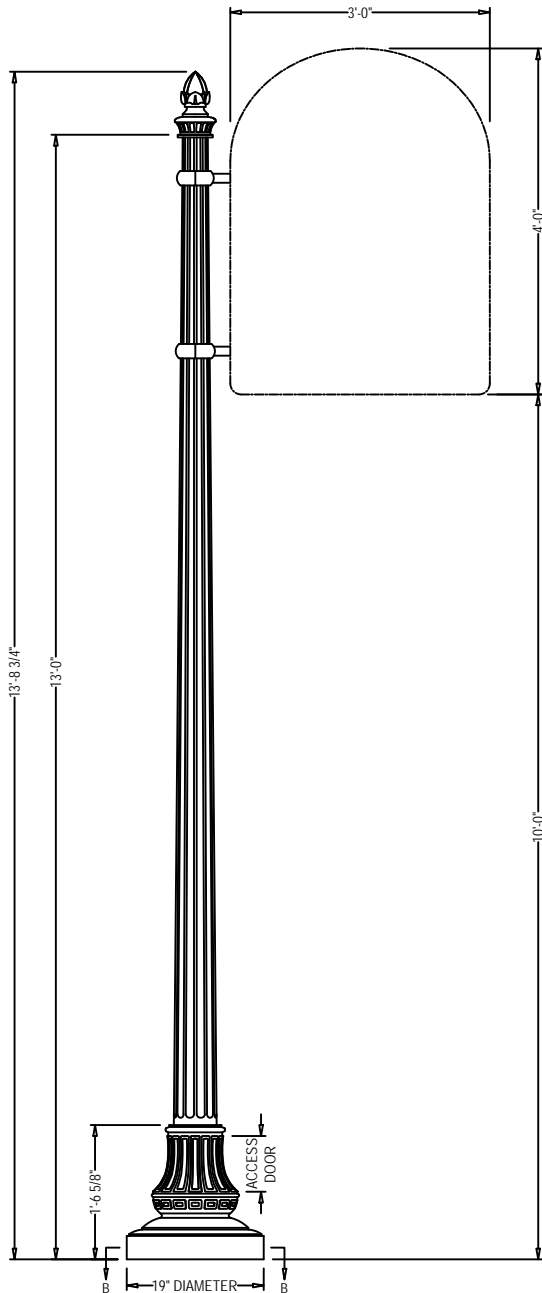

LAMP POST SPECIFICATIONS

STYLE: Capistrano

HEIGHT: 13'-0"

BASE: 19" Diameter

MATERIAL: Cast Aluminum Alloy ANSI 356 Per A.S.T.M. B26-95

FINISH: Powder Coat - To match Frazee Custom Color CZ-12-2935

ACCESS DOOR: Located in base secured with tamper proof hex socket security machine screws

GROUND STUD PROVISIONS: Drill and tap inside wall of base opposite access door to accommodate a 1/4"-20 ground stud (stud by others)

ANCHOR BOLTS: (4) 3/4" X 24" + 3" hook (fully galvanized with 1 galvanized nut and 1 galvanized washer per bolt)

BOLT PROJECTION: 3" required

TENON: 2 7/8" DIA. X 2" High (To Accept Finial)

CATALOG NUMBER:

Shaft -

APSCPS-19-12.50-2F-TN2.88/2.00-CU

Pole Finial - AFNWSO-04-08.75-CU

SPRING CITY ELECTRICAL MFG. CO.

Hall and Main Streets - P.O. Box 19 -

Spring City, PA 19475

PHONE (610) 948-4000

FAX (610) 948-5577

www.springcity.com

DESCRIPTION:

The 13'-0" Capistrano Aluminum Post with Pedestrian Orientation Sign

FIGURE 21

OVAL HANGING/ WALL-MOUNTED BUILDING & LOCATION

The following signs are to be used to help guests identify different buildings and restrooms in a pedestrian orientation.

NOTES

The following illustrates the oval hanging/wall-mounted building and location signage used throughout the park. Sign to be 3" thick and manufactured of painted aluminum.

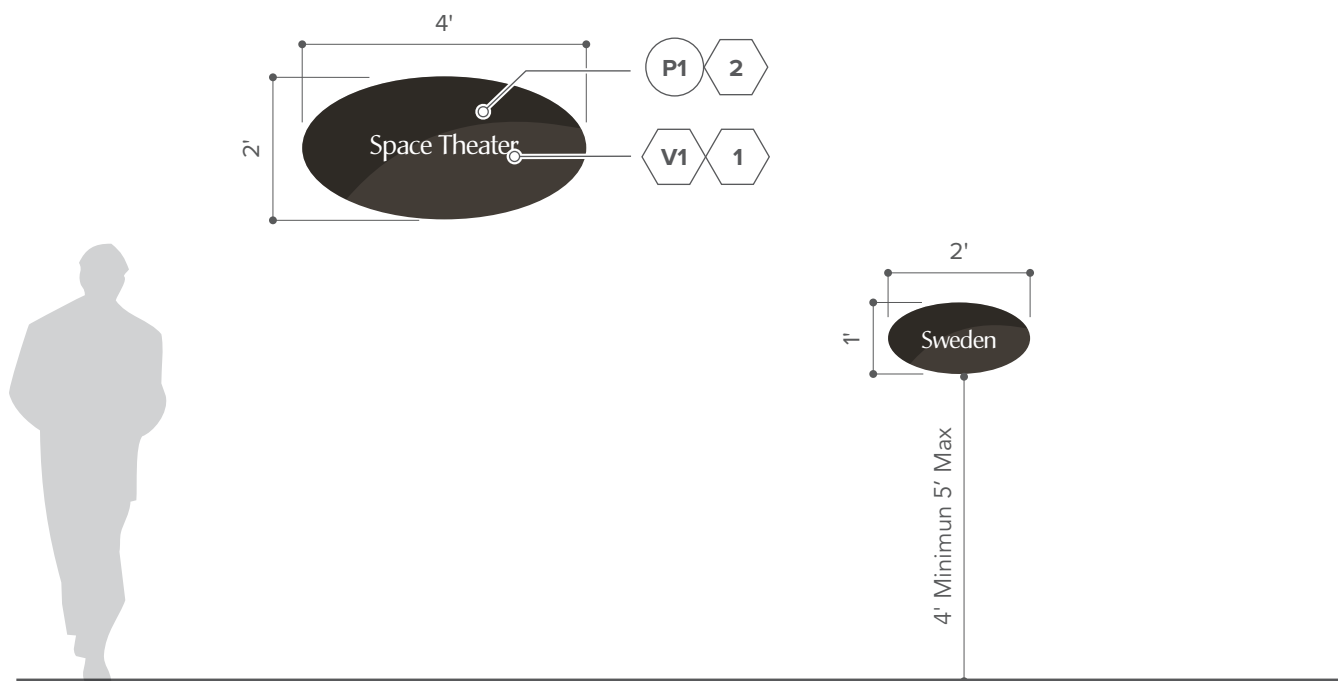

1 Front Elevation
Scale : 3/8"=1'

FIGURE 21A

OVAL HANGING/WALL-MOUNTED BUILDING & LOCATION (DETAILS)

The following illustrates the oval hanging/wall-mounted building and location signage in detail, verifying materials used and measurements for the layout of the sign.

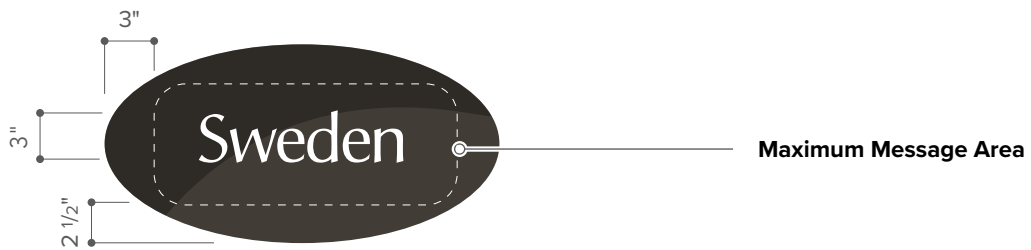

2 Front Elevation
Scale : 1"=1'

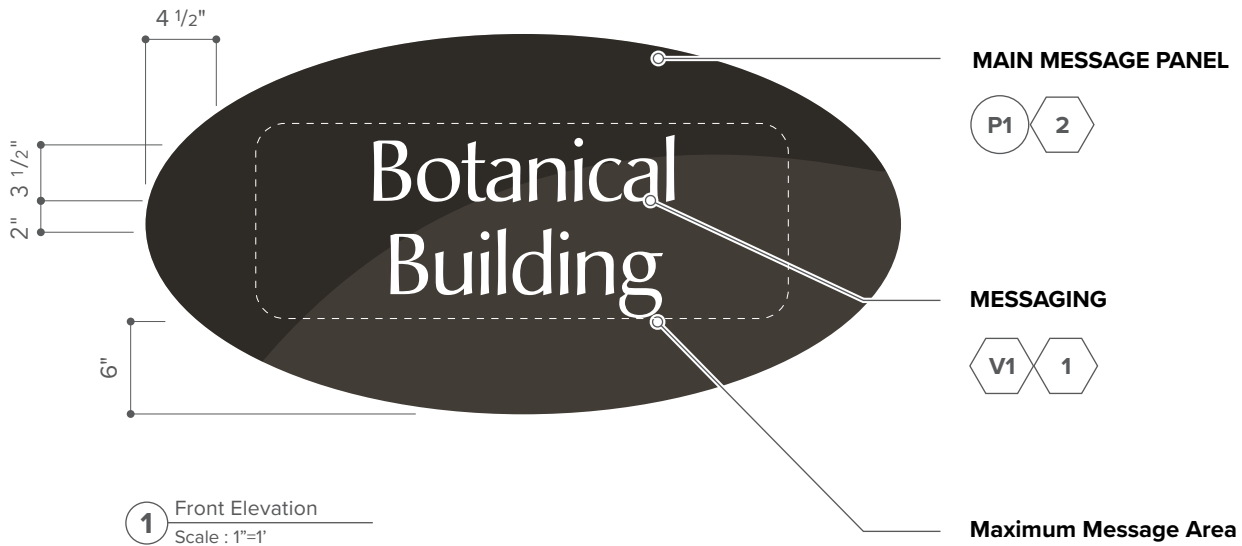

1 Front Elevation
Scale : 1"=1'

FIGURE 22 RESTROOM IDENTITY (DETAILS)

The following illustrates the restroom signage in detail, verifying materials used and measurements for the layout of the sign. ADA sign fabricator to confirm.

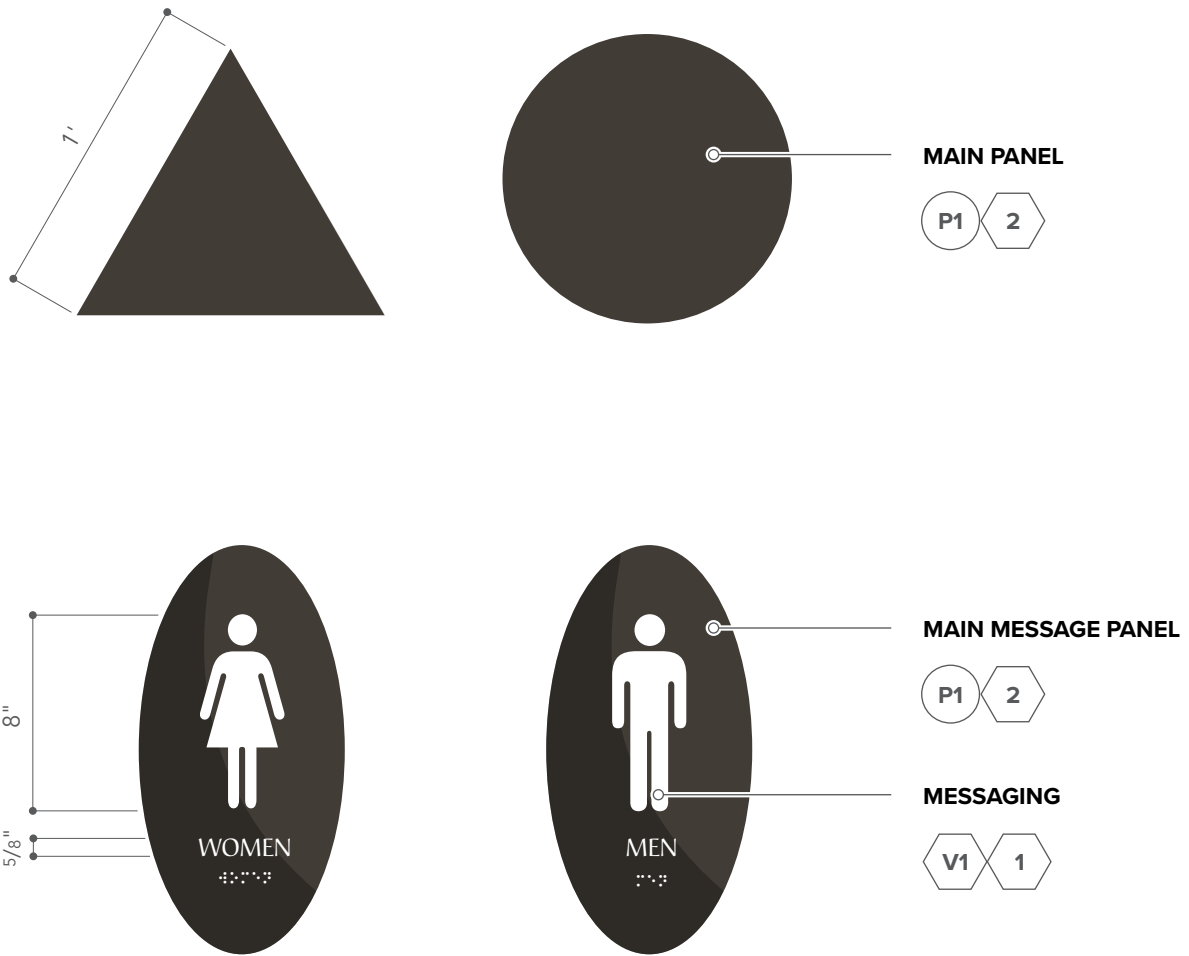

1 Front Elevation
Scale : 1 1/2"=1'

FIGURE 23 1-SIDED BUILDING & LOCATION

The following freestanding sign is to be used to identify various buildings when a building mounted sign is not available. There should be no more than one of these signs per building / destination.

NOTES

The following illustrates the 1-sided building and location signage used throughout the park. Sign to be 3" thick and manufactured of painted aluminum with a 60° arch top and 1-1/2" radius bottom corners.

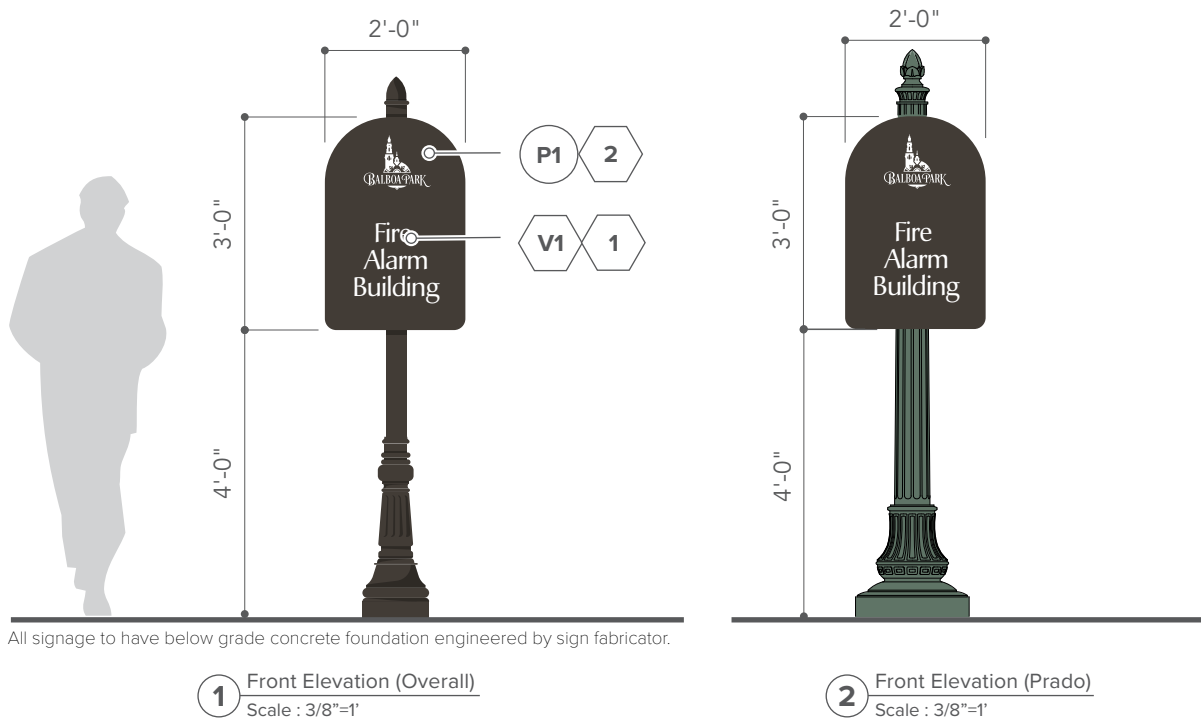

All signage to have below grade concrete foundation engineered by sign fabricator.

FIGURE 23A

1-SIDED BUILDING & LOCATION (DETAILS)

The following illustrates the 1-sided building and location signage in detail, verifying materials used and measurements for the layout of the sign.

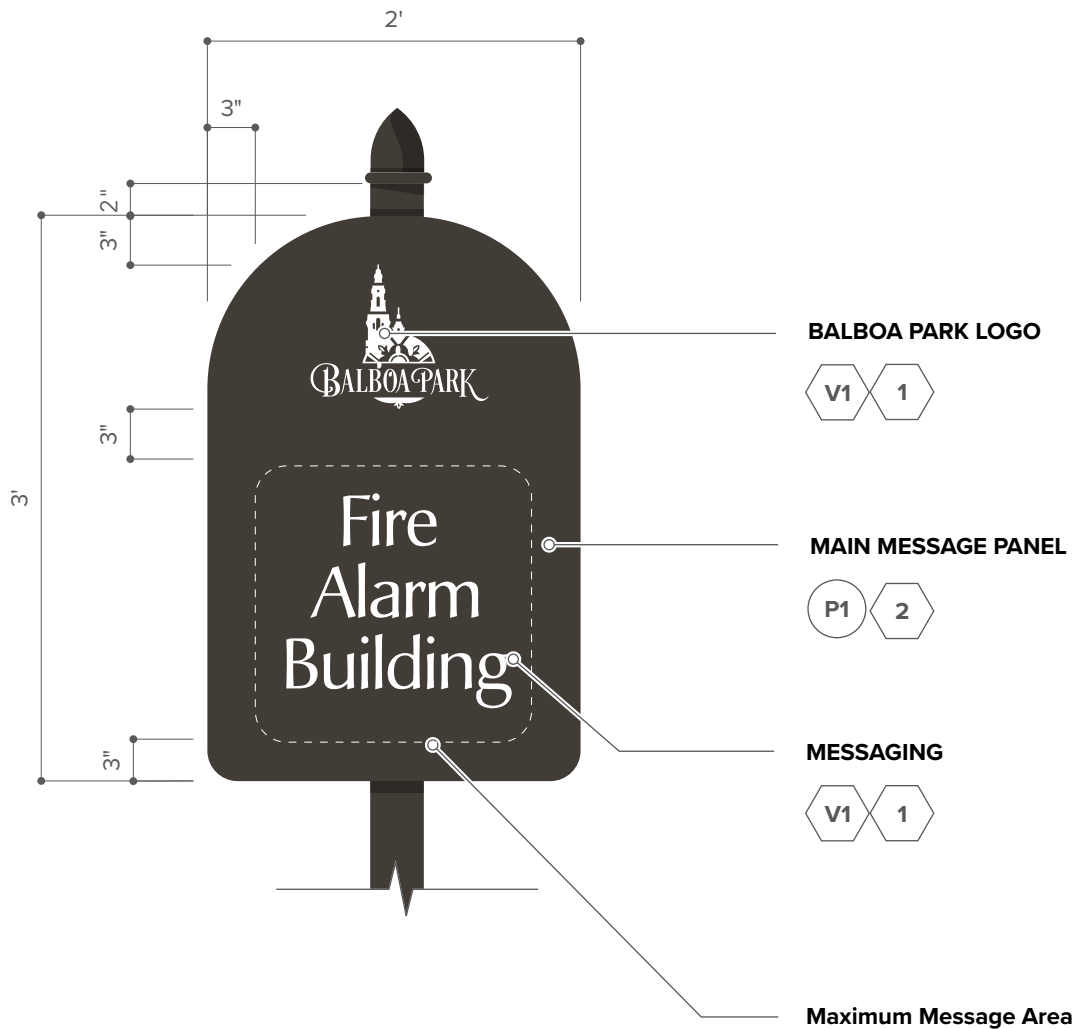

1 Front Elevation
Scale : 1"=1'

FIGURE 23B

1-SIDED BUILDING & LOCATION POLE FOR OVERALL PARK

Mini-Mariner Pole

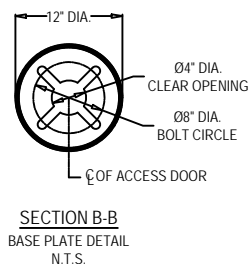
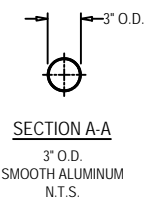
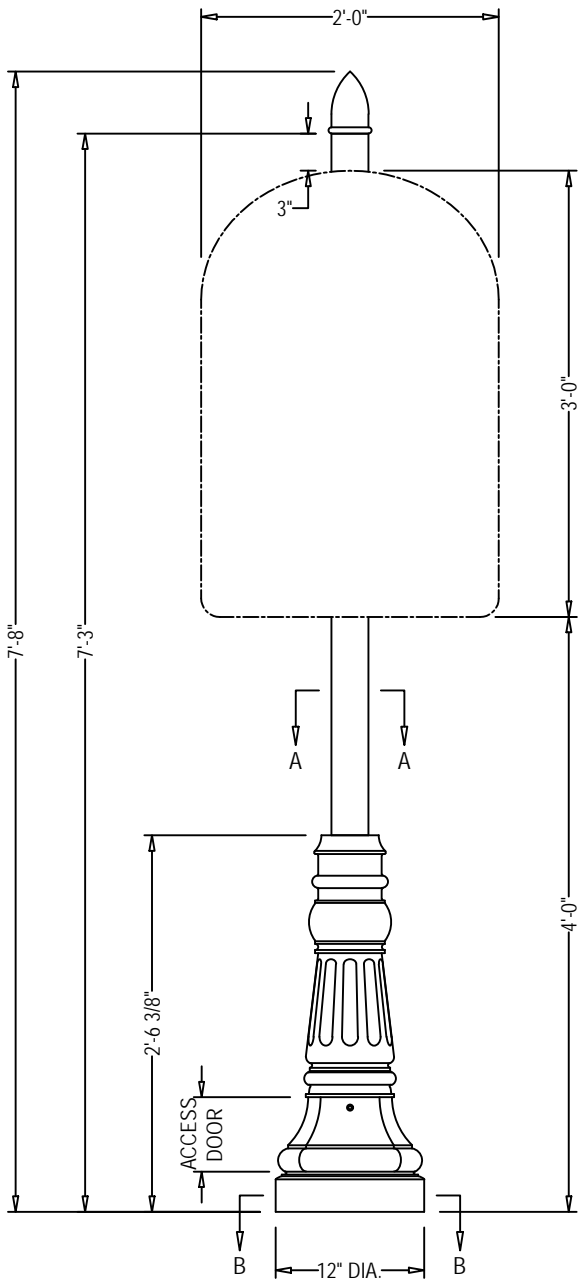

LAMP POST SPECIFICATIONS

STYLE: Mini-Mariner

HEIGHT: 7'3"

BASE: 12" Diameter

MATERIAL: Shaft - 2 1/2" SCH-40 Aluminum Pipe (3" OD) 6061-T6
Base - Cast Aluminum Alloy A.N.S.I. 356, PER A.S.T.M. B26-95

FINISH: Powder Coat - To match Corinthian Bronze Metallic

ACCESS DOOR: Located in base secured with tamper proof hex socket security machine screws

GROUND PROVISIONS: Drill and tap inside base opposite access door to accommodate a 1/4"-20 ground stud (stud by others)

ANCHOR BOLTS: (4) 3/4" X 17" + 3" hook (fully galvanized with 1 galvanized nut and 1 galvanized washer per bolt)

BOLT PROJECTION: 3" required

CATALOG NUMBER:
Pole - APSMNM-12-07.00-S30-CU
Pole Finial - AFNBLB-3.0-05.00-CU

SPRING CITY ELECTRICAL MFG. CO.
Hall and Main Streets - P.O. Box 19 -
Spring City, PA 19475
PHONE (610) 948-4000
FAX (610) 948-5577
www.springcity.com

DESCRIPTION:
The 7'3" Mini-Mariner with One-Sided Building & Location Sign

FIGURE 23C

1-SIDED BUILDING & LOCATION POLE FOR PRADO AREA

Capistrano Pole

Please note that this pole type will only be used within the Prado area of the park.

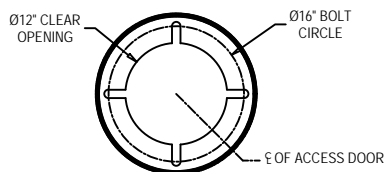
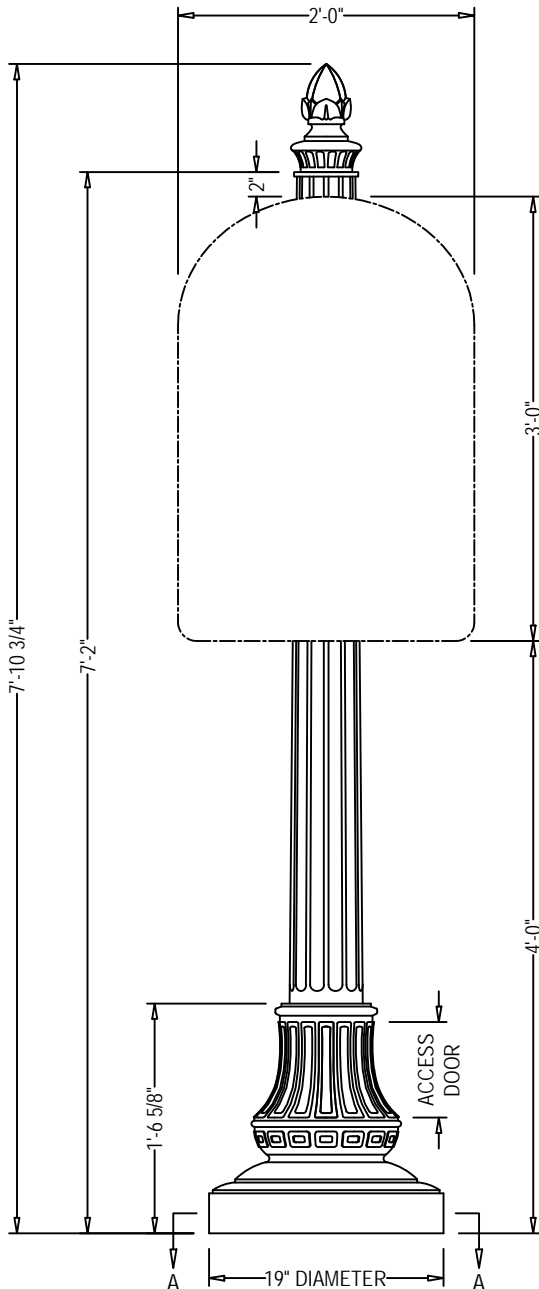

LAMP POST SPECIFICATIONS

STYLE: Capistrano

HEIGHT: 7'-2"

BASE: 19" Diameter

MATERIAL: Cast Aluminum Alloy ANSI 356 Per A.S.T.M. B26-95

FINISH: Powder Coat - To match Frazee Custom Color CZ-12-2935

ACCESS DOOR: Located in base secured with tamper proof hex socket security machine screws

GROUND STUD PROVISIONS: Drill and tap inside wall of base opposite access door to accommodate a 1/4"-20 ground stud (stud by others)

ANCHOR BOLTS: (4) 3/4" X 24" + 3" hook (fully galvanized with 1 galvanized nut and 1 galvanized washer per bolt)

BOLT PROJECTION: 3" required

TENON: 2 7/8" DIA. X 2" High (To Accept Finial)

CATALOG NUMBER:

Shaft -

APSCPS-19-12.50-2F-TN2.88/2.00-CU

Pole Finial - AFNSO-04-08.75-CU

SPRING CITY ELECTRICAL MFG. CO.

Hall and Main Streets - P.O. Box 19 -

Spring City, PA 19475

PHONE (610) 948-4000

FAX (610) 948-5577

www.springcity.com

DESCRIPTION:

The 7'2" Capistrano Aluminum Post with One-Sided Building & Location Sign

FIGURE 24

2-SIDED BUILDING & LOCATION

The following freestanding sign is to be used to identify various buildings when a building mounted sign is not available. There should be no more than one of these signs per building / destination.

NOTES

The following illustrates the 2-sided building and location signage used throughout the park. Sign to be 3" thick and manufactured of painted aluminum with a 60° arch top and 1-1/2" radius bottom corners.

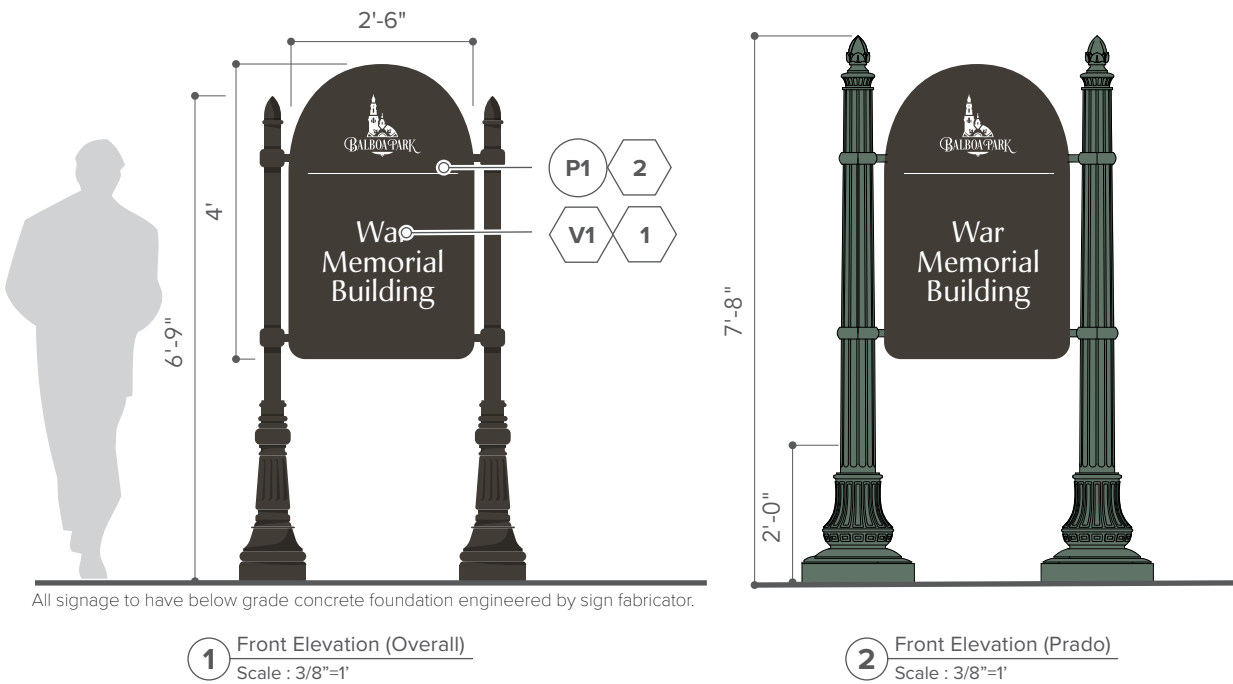
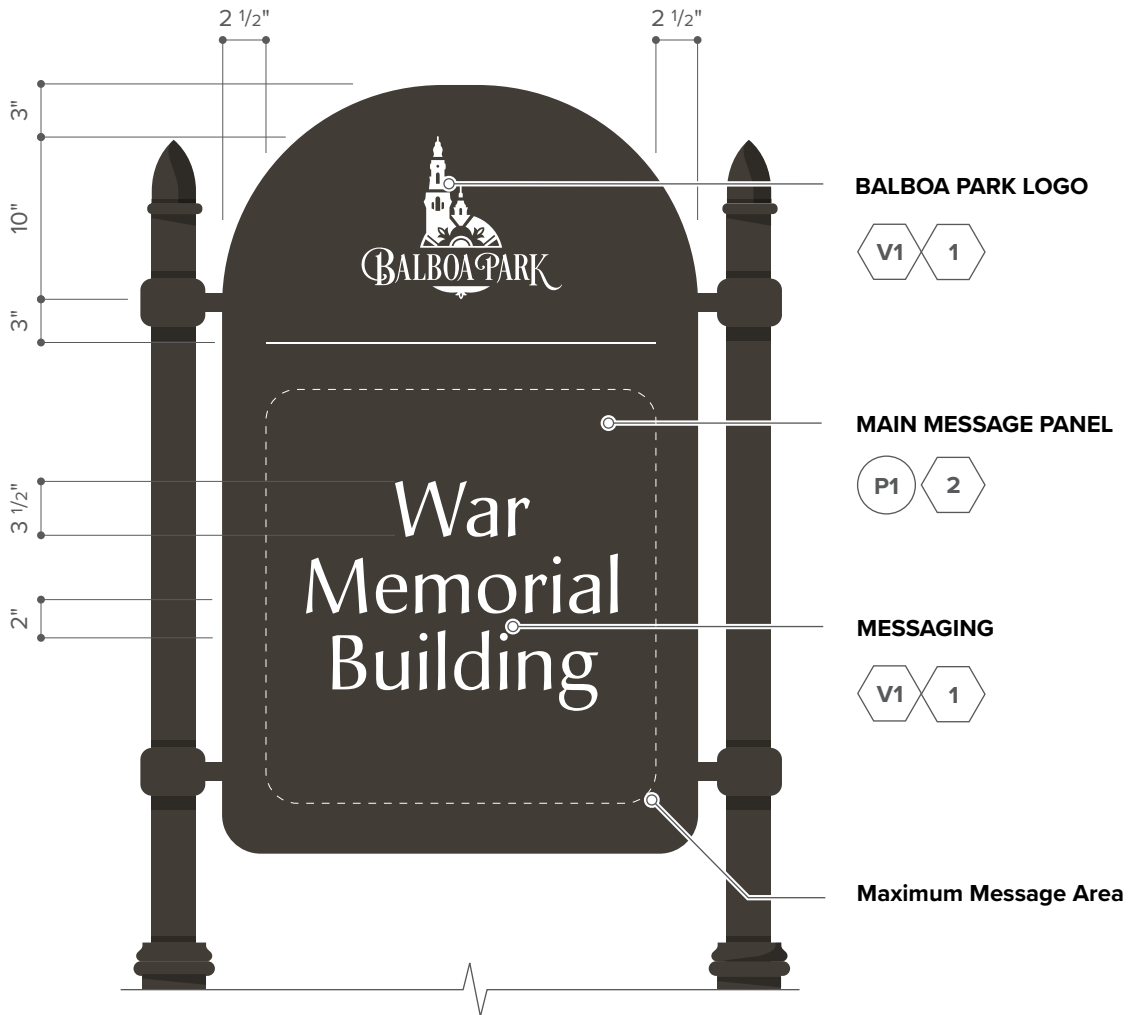

FIGURE 24A

2-SIDED BUILDING & LOCATION (DETAILS)

The following illustrates the 1-sided building and location signage in detail, verifying materials used and measurements for the layout of the sign.



1 Front Elevation
Scale : 1"=1'

FIGURE 24B

2-SIDED BUILDING & LOCATION POLE FOR OVERALL PARK

Mini-Mariner Pole

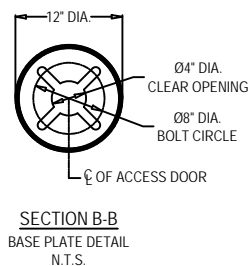
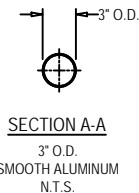
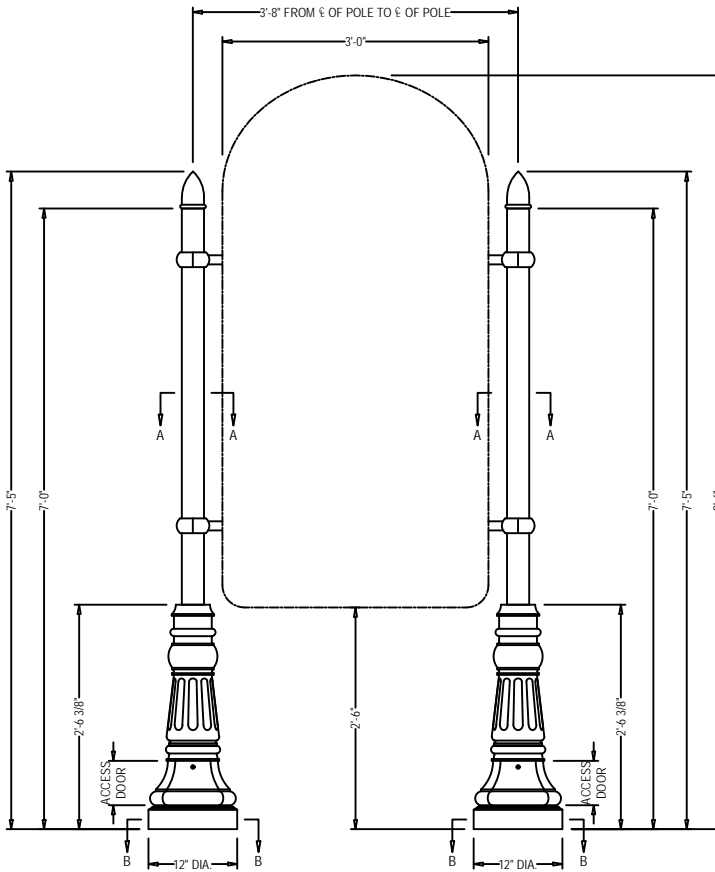

LAMP POST SPECIFICATIONS

STYLE: Mini-Mariner

HEIGHT: 7'0"

BASE: 12" Diameter

MATERIAL: Shaft - 2 1/2" SCH-40 Aluminum Pipe (3" OD) 6061-T6
Base - Cast Aluminum Alloy A.N.S.I. 356, PER A.S.T.M. B26-95

FINISH: Powder Coat - To match Corinthian Bronze Metallic

ACCESS DOOR: Located in base secured with tamper proof hex socket security machine screws

GROUND PROVISIONS: Drill and tap inside base opposite access door to accommodate a 1/4"-20 ground stud (stud by others)

ANCHOR BOLTS: (4) 3/4" X 17" + 3" hook (fully galvanized with 1 galvanized nut and 1 galvanized washer per bolt)

BOLT PROJECTION: 3" required

CATALOG NUMBER:
Pole - APSMNM-12-07.00-S30-CU
Pole Finial - AFNBLB-3.0-05.00-CU

SPRING CITY ELECTRICAL MFG. CO.
Hall and Main Streets - P.O. Box 19 -
Spring City, PA 19475
PHONE (610) 948-4000
FAX (610) 948-5577
www.springcity.com

DESCRIPTION:
The 7'0" Mini-Mariner with Pedestrian Orientation Sign

FIGURE 24C

2-SIDED BUILDING & LOCATION POLE FOR PRADO AREA

Capistrano Pole

Please note that this pole type will only be used within the Prado area of the park.

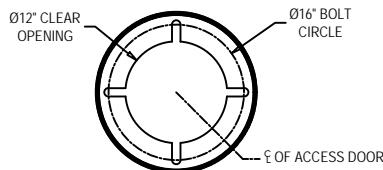
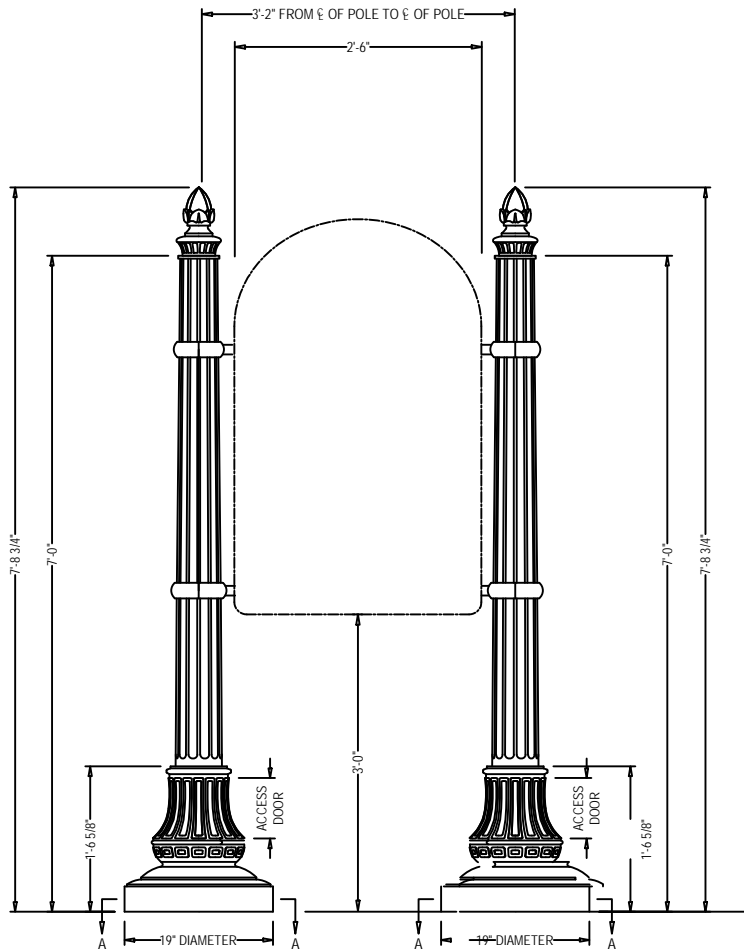

SECTION A-A
N.T.S.

LAMP POST SPECIFICATIONS

STYLE: Capistrano

HEIGHT: 7'-0"

BASE: 19" Diameter

MATERIAL: Cast Aluminum Alloy ANSI 356 Per A.S.T.M. B26-95

FINISH: Powder Coat - To match Frazee Custom Color CZ-12-2935

ACCESS DOOR: Located in base secured with tamper proof hex socket security machine screws

GROUND STUD PROVISIONS: Drill and tap inside wall of base opposite access door to accommodate a 1/4"-20 ground stud (stud by others)

ANCHOR BOLTS: (4) 3/4" X 24" + 3" hook (fully galvanized with 1 galvanized nut and 1 galvanized washer per bolt)

BOLT PROJECTION: 3" required

TENON: 2 7/8" DIA. X 2" High (To Accept Finial)

CATALOG NUMBER:

Shaft - APSCPS-19-12.50-2F-TN2.88/2.00-CU
Pole Finial - AFNSO-04-08.75-CU

SPRING CITY ELECTRICAL MFG. CO.

Hall and Main Streets - P.O. Box 19 -
Spring City, PA 19475
PHONE (610) 948-4000
FAX (610) 948-5577
www.springcity.com

DESCRIPTION:

The 7'0" Capistrano Aluminum Post with 2-Sided Building & Location

FIGURE 25 BANNER STANDARD

The following illustrates the banner standard used throughout the park. The color and name printed on the banner will be specific to which district it is located in.

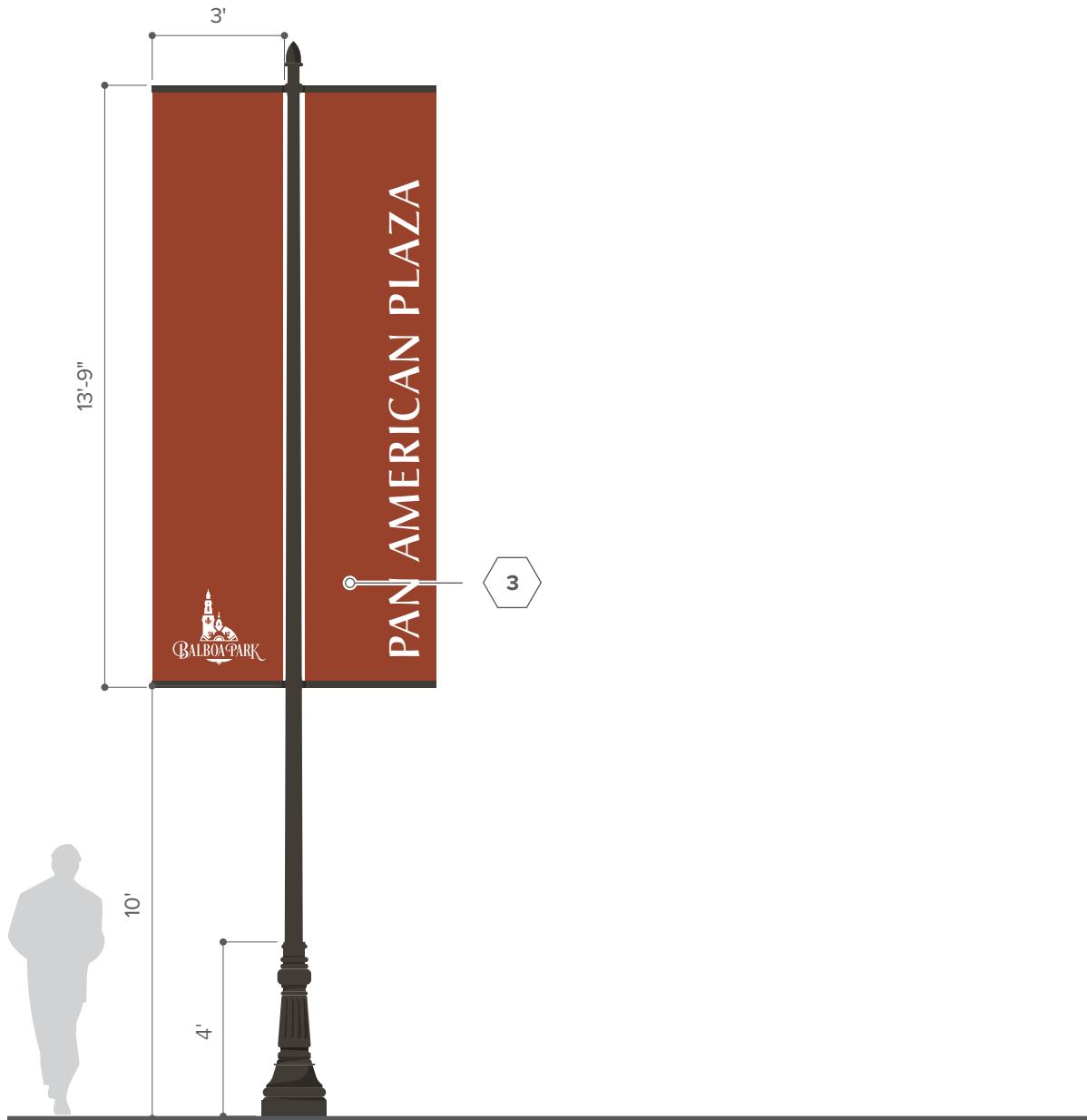

All signage to have below grade concrete foundation engineered by sign fabricator.

1 Front Elevation
Scale : 1/4"=1'

FIGURE 25A
BANNER STANDARD (HISTORICAL AREA)



FIGURE 26

1-SIDED HISTORICAL LANDMARK

The following freestanding sign is to be used to identify historical landmarks throughout the park. It uses the historic seal and is for buildings or landmarks such as the organ pavilion that were created for the Exposition.

NOTES

The following sign has a unique pole due to the location being within the historical area of the park and the requirements specified within in the Masterplan. Sign to be 3" thick and manufactured of painted aluminum with a 60° arch top and 1-1/2" radius bottom corners.

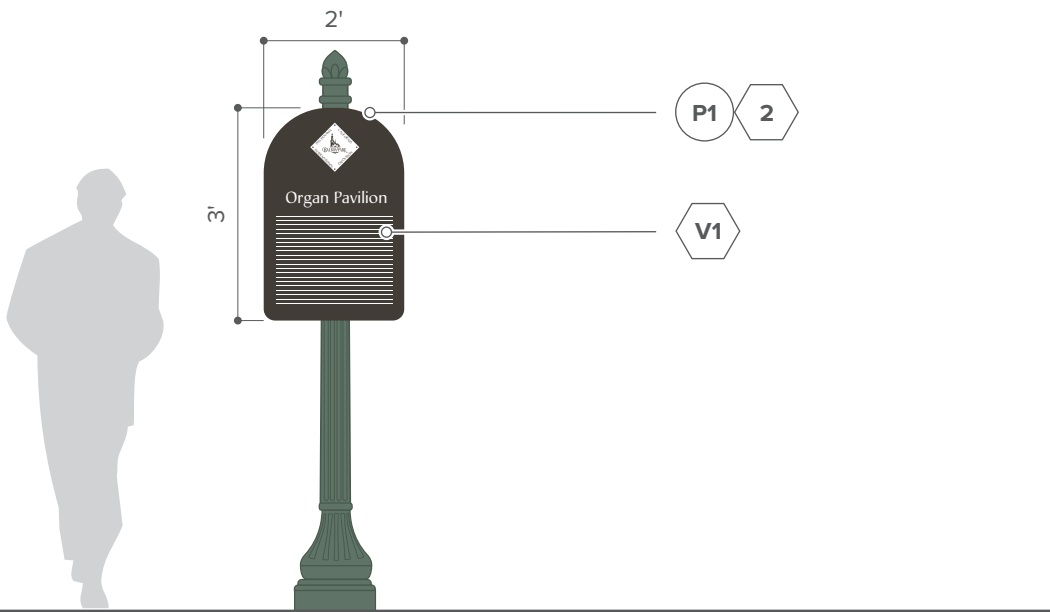

All signage to have below grade concrete foundation engineered by sign fabricator.

1 Front Elevation (Mariner)
Scale : 3/8"=1'

FIGURE 26A

1-SIDED HISTORICAL LANDMARK (DETAILS)

The following illustrates the 1-sided historical landmark signage in detail, verifying materials used and measurements for the layout of the sign.

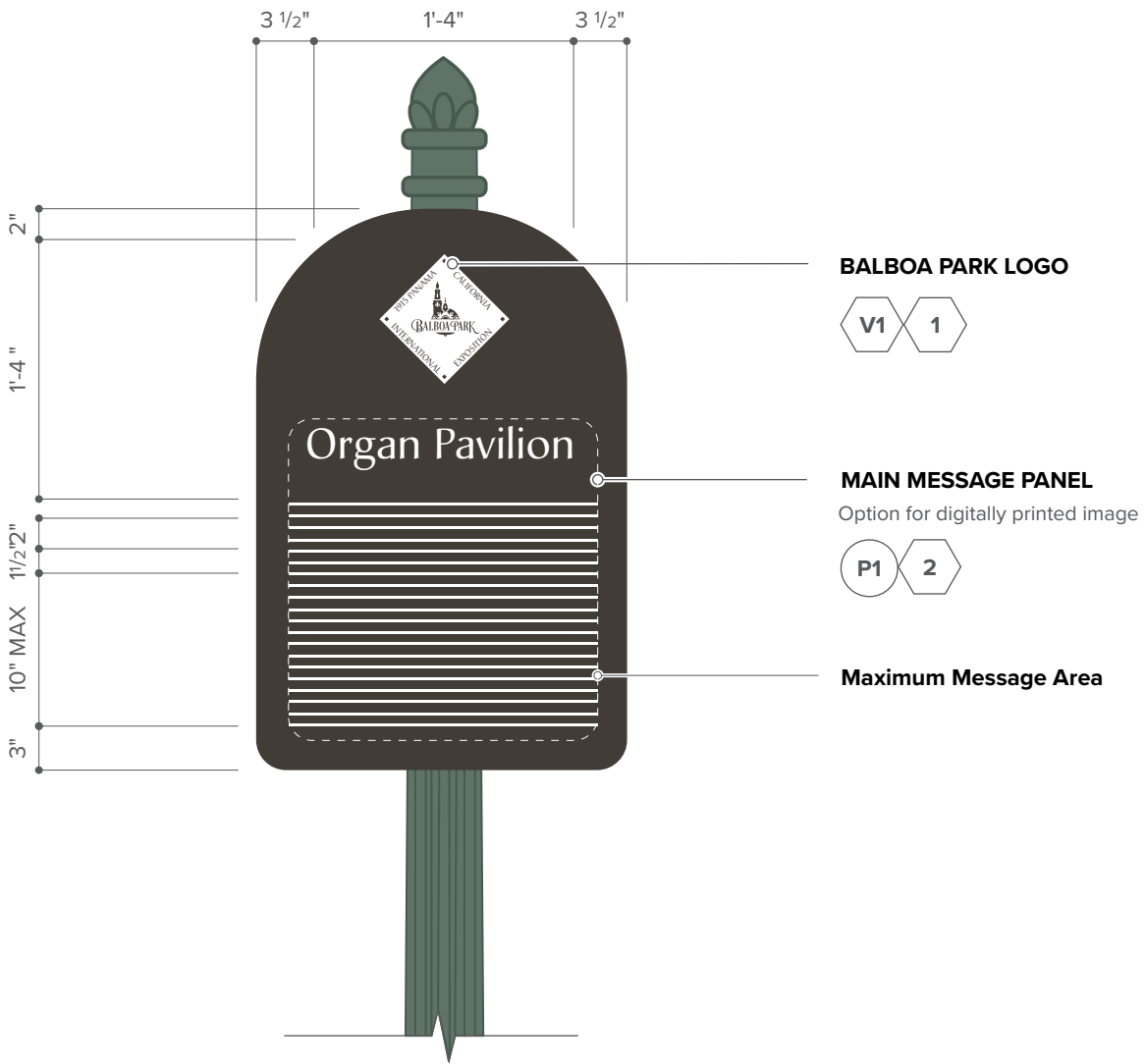

1 Front Elevation
Scale : 1"=1'

FIGURE 26B

ONE-SIDED HISTORICAL LANDMARK POLE

Capistrano Pole

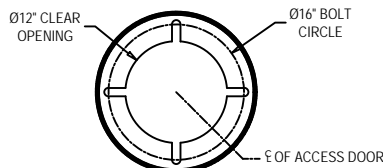
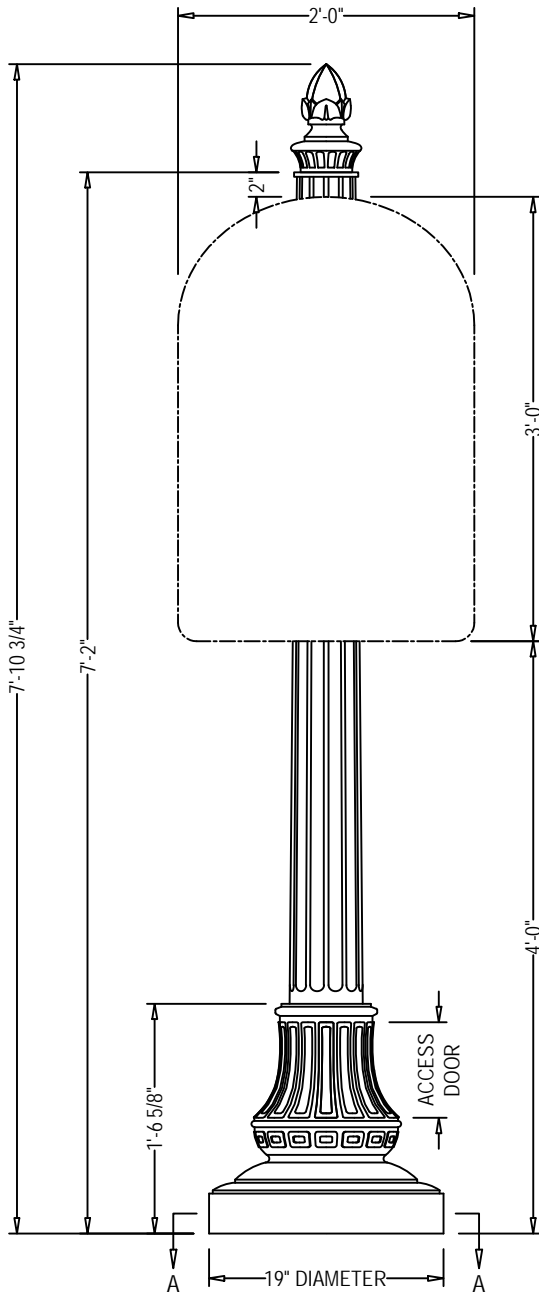

SECTION A-A
N.T.S.

LAMP POST SPECIFICATIONS

STYLE: Capistrano

HEIGHT: 7'-2"

BASE: 19" Diameter

MATERIAL: Cast Aluminum Alloy ANSI 356 Per A.S.T.M. B26-95

FINISH: Powder Coat - To match Frazee Custom Color CZ-12-2935

ACCESS DOOR: Located in base secured with tamper proof hex socket security machine screws

GROUND STUD PROVISIONS: Drill and tap inside wall of base opposite access door to accommodate a 1/4"-20 ground stud (stud by others)

ANCHOR BOLTS: (4) 3/4" X 24" + 3" hook (fully galvanized with 1 galvanized nut and 1 galvanized washer per bolt)

BOLT PROJECTION: 3" required

TENON: 2 7/8" DIA. X 2" High (To Accept Finial)

CATALOG NUMBER:

Shaft - APSCPS-19-12.50-2F-TN2.88/2.00-CU
Pole Finial - AFNSO-04-08.75-CU

SPRING CITY ELECTRICAL MFG. CO.

Hall and Main Streets - P.O. Box 19 -
Spring City, PA 19475
PHONE (610) 948-4000
FAX (610) 948-5577
www.springcity.com

DESCRIPTION:

The 7'2" Capistrano Aluminum Post with One-Sided Building & Location Sign

SECTION 4

NEW PROPOSED SIGNAGE

FIGURE 27 HIGH SPEED VEHICULAR DIRECTIONAL

The following illustrates the high speed vehicular directional proposed to be used at the primary vehicular arteries throughout the site. Sign to be manufactured of painted aluminum with white vinyl messaging and clear coat finish.

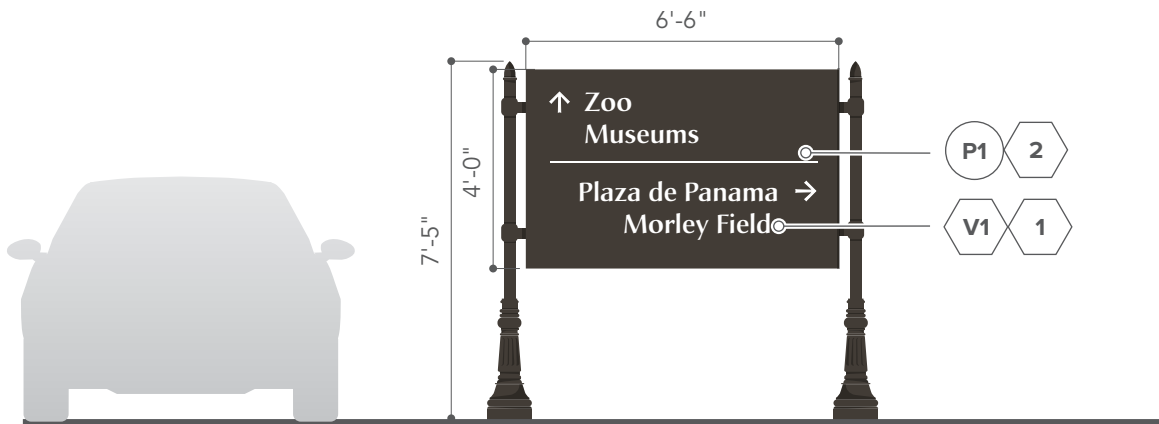

All signage to have below grade concrete foundation engineered by sign fabricator.

1 Front Elevation
Scale : 1/4"=1'

FIGURE 27A HIGH SPEED VEHICULAR DIRECTIONAL (DETAILS)

The following illustrates the high speed vehicular directional in detail, verifying materials used, measurements for the layout of the sign and the maximum messaging area.

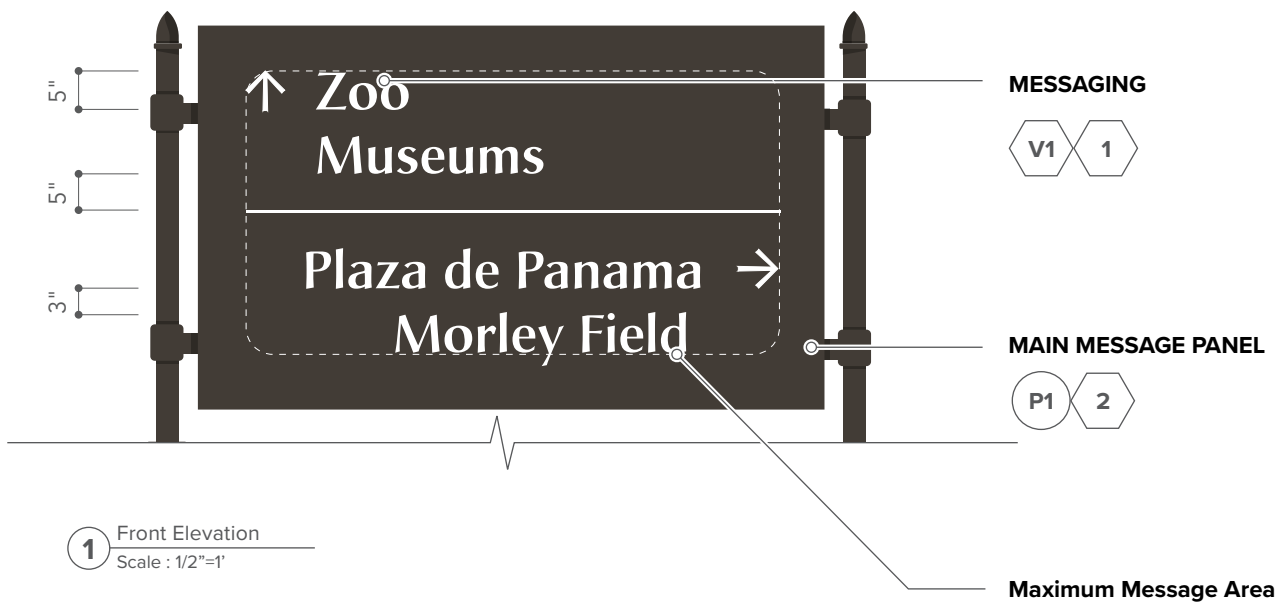
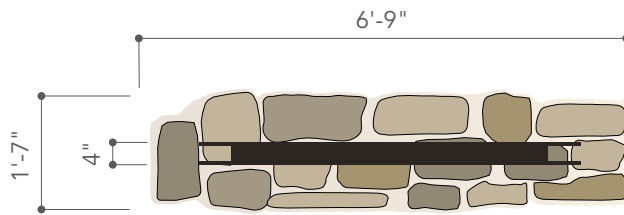

FIGURE 28 AMENITY IDENTITY MONUMENT

The following illustrates the amenity identity monument proposed to be used throughout the various areas of the park. Supports can be modified to reflect the architectural character of the location of the amenity within the Park.

NOTES

Sign to be 5" thick and manufactured of painted aluminum with a 60° arch top and 1-1/2" radius bottom corners.



1 Plan Elevation
Scale : 3/8"=1'



All signage to have below grade concrete foundation engineered by sign fabricator.

1 Front Elevation
Scale : 3/8"=1'

FIGURE 28A

AMENITY IDENTITY MONUMENT

The following illustrates the typical posts to be used, if not modified to reflect the architectural character of the area in which the sign is located. Sign panel to be manufactured of painted aluminum. The following illustrates the typical posts to be used, if not modified to reflect the architectural character of the area in which the sign is located.

NOTES

Sign to be 5" thick and manufactured of painted aluminum with a 60° arch top and 1-1/2" radius bottom corners.

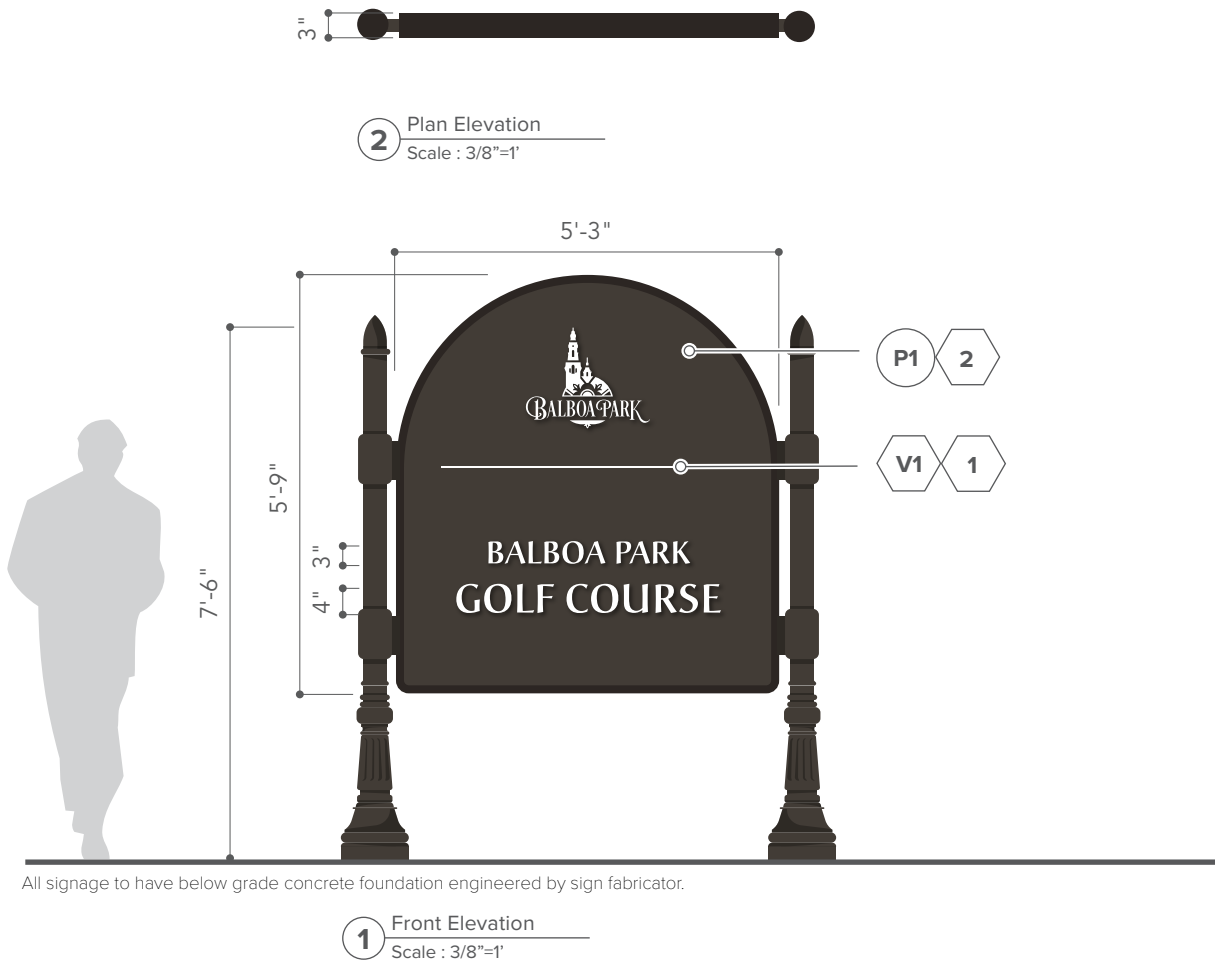
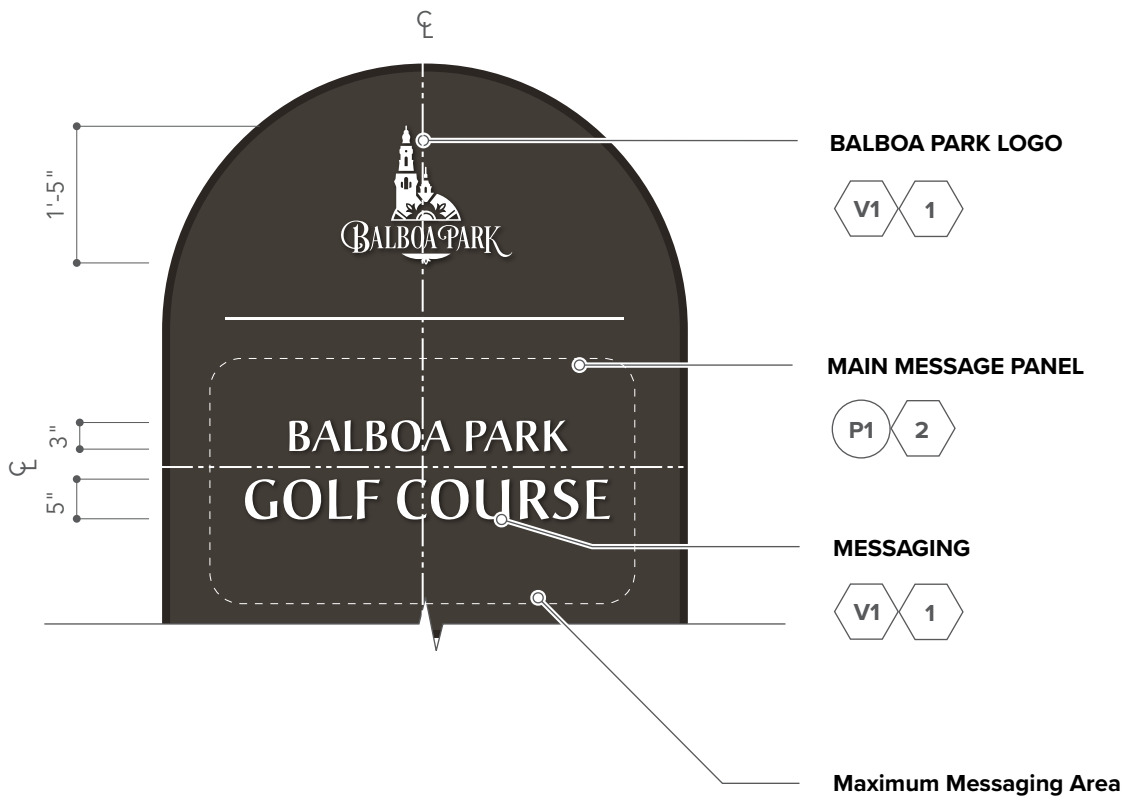

FIGURE 28B

AMENITY IDENTITY MONUMENT (DETAILS)

The following illustrates the high speed vehicular directional in detail, verifying materials used, measurements for the layout of the sign and the maximum messaging area.



1 Front Elevation
Scale : 1/2"=1'

FIGURE 29 BALBOA PARK IDENTITY

The following sign is to be used at pedestrian entries to help identify the Park as well as create a sense of arrival and help define the edges of the site. Sign to be manufactured of painted aluminum.

NOTES

Sign to be 3" thick and manufactured of painted aluminum with a 60° arch top and 1-1/2" radius bottom corners.

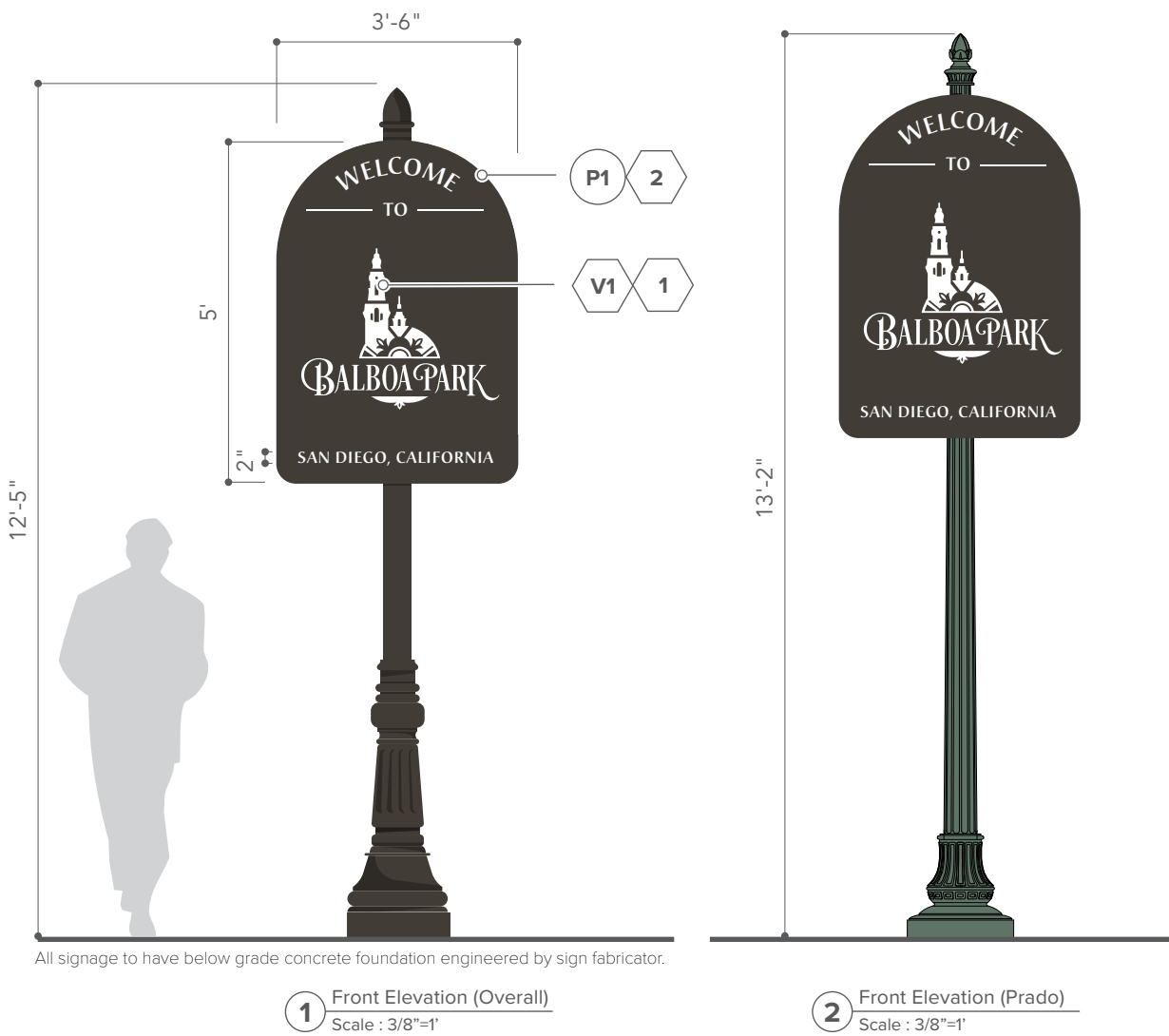
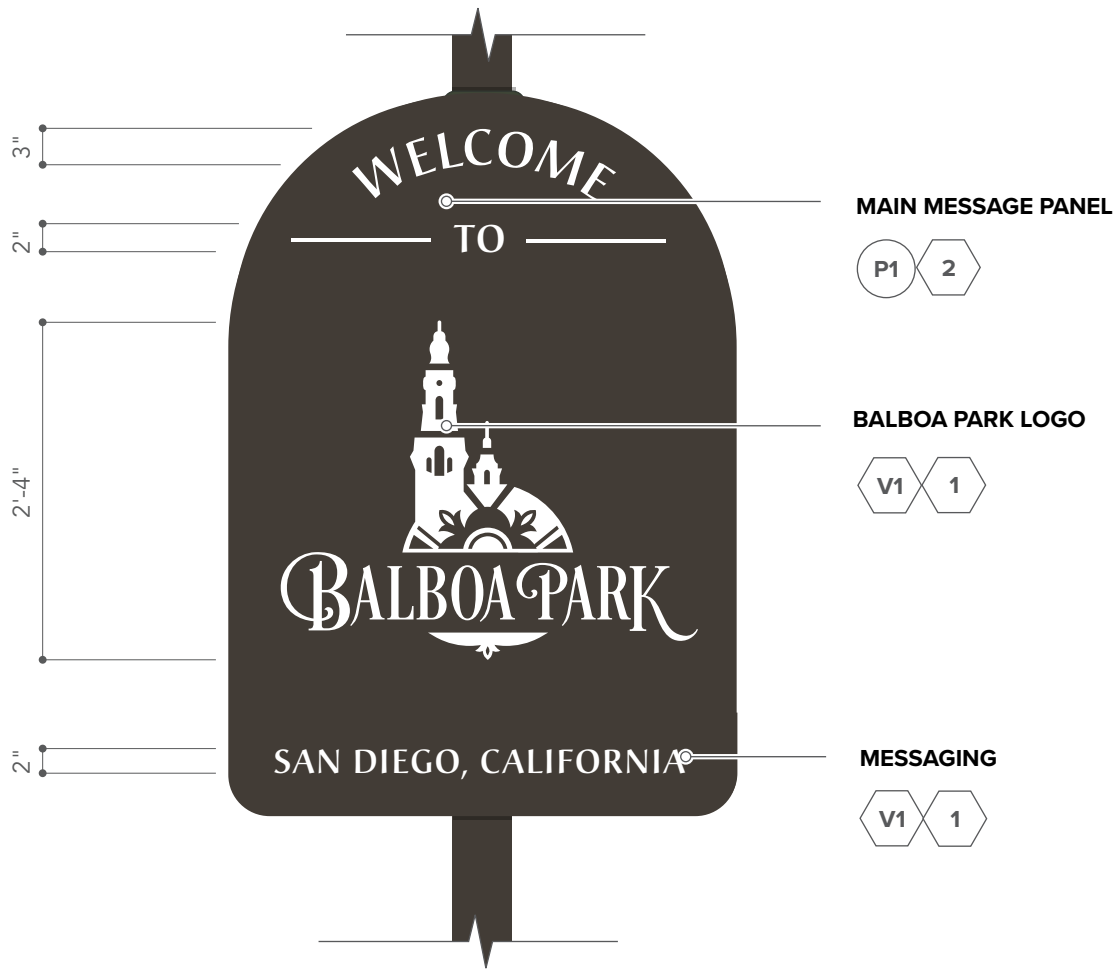

FIGURE 29A BALBOA PARK IDENTITY (DETAILS)

The following illustrates the Balboa Park identity in detail, verifying materials used and measurements for the layout of the sign.



1 Front Elevation
Scale : 3/4"=1'

FIGURE 30 PARKING LOT IDENTITY

The following sign is to be used to help guests identify the parking lot they are parking in and the destinations or amenities that are easily accessible. Sign to be manufactured of painted aluminum

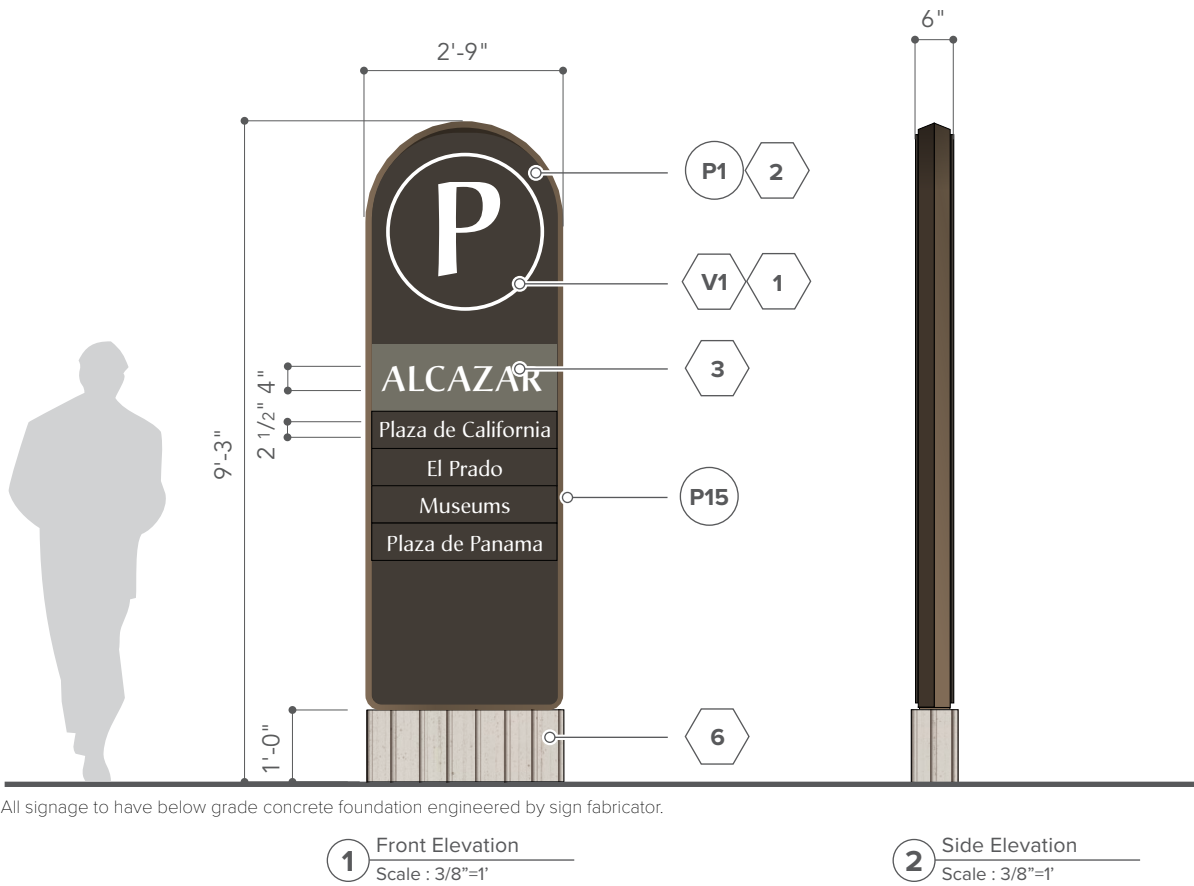

All signage to have below grade concrete foundation engineered by sign fabricator.

FIGURE 30A PARKING LOT IDENTITY (DETAILS)

The following illustrates the Parking Lot Identity in detail, verifying materials used and measurements for the layout of the sign. The Parking lot color which change based on the district the sign is in.



1 Front Elevation
Scale : 3/4"=1'

FIGURE 31 PARKING LOT DIGITAL

The following sign is to be used to help direct guests throughout the park as well as to various parking lots when lots are full during large events. Sign to be manufactured of painted aluminum with integrated LED digital messaging.



1 Plan Elevation
Scale : 3/8"=1'

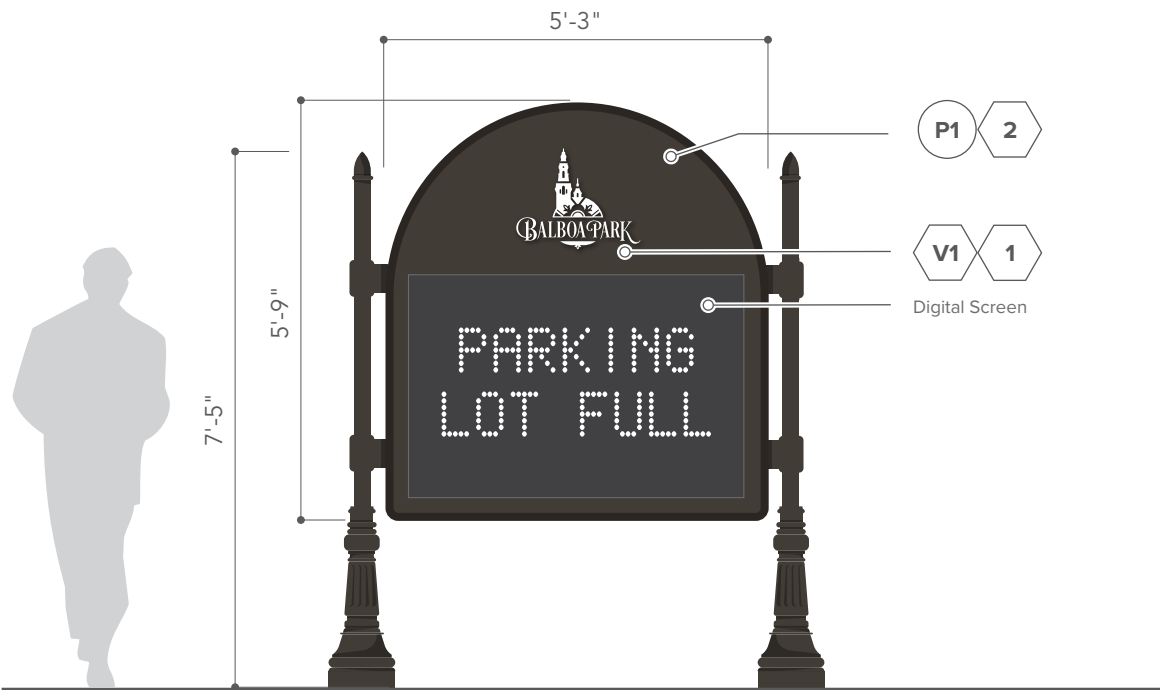

1 Front Elevation
Scale : 3/8"=1'

All signage to have below grade concrete foundation engineered by sign fabricator.

FIGURE 32 PARKING IDENTITY

The following sign is to be mounted to existing light poles throughout the various parking lots to help identify guests and users of where they parked.

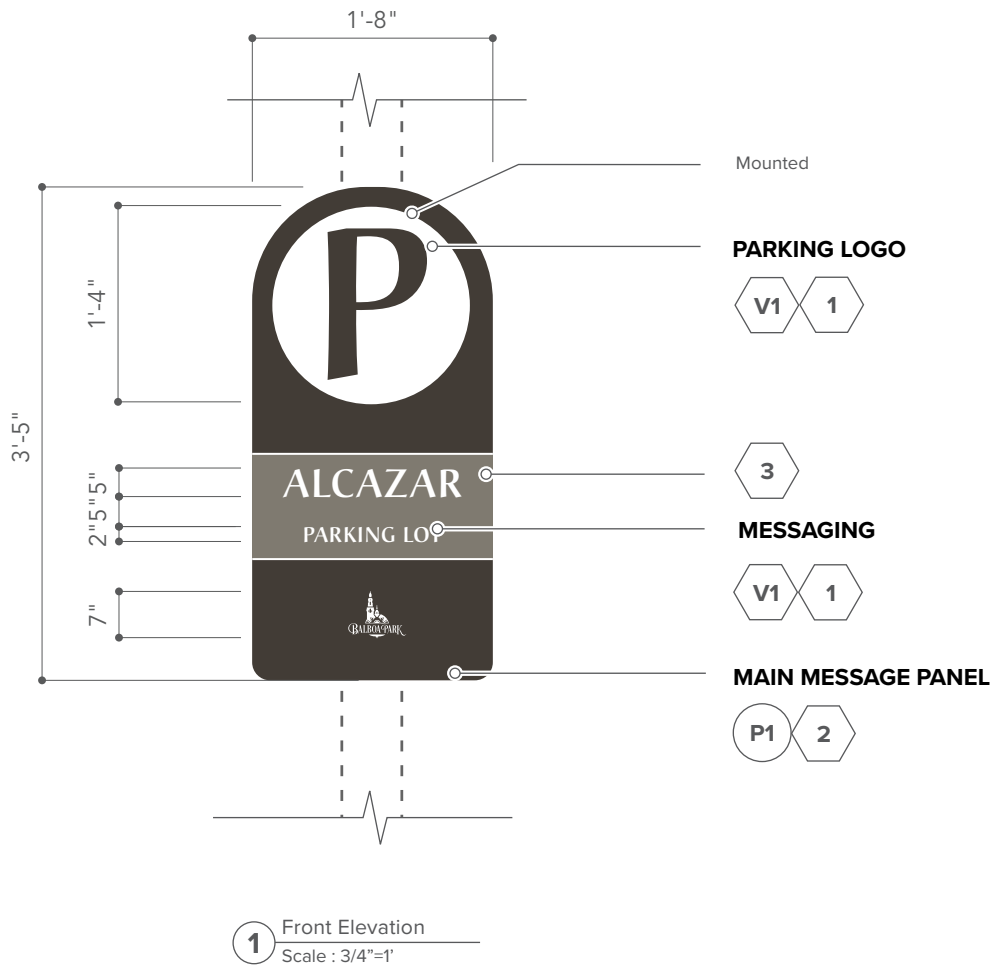

FIGURE 33 TRAM STOP

The following sign is to be used at the various tram stops to help guests identify where they currently are and how to get to different areas of the park based on the different tram routes. Sign to be manufactured of painted aluminum.

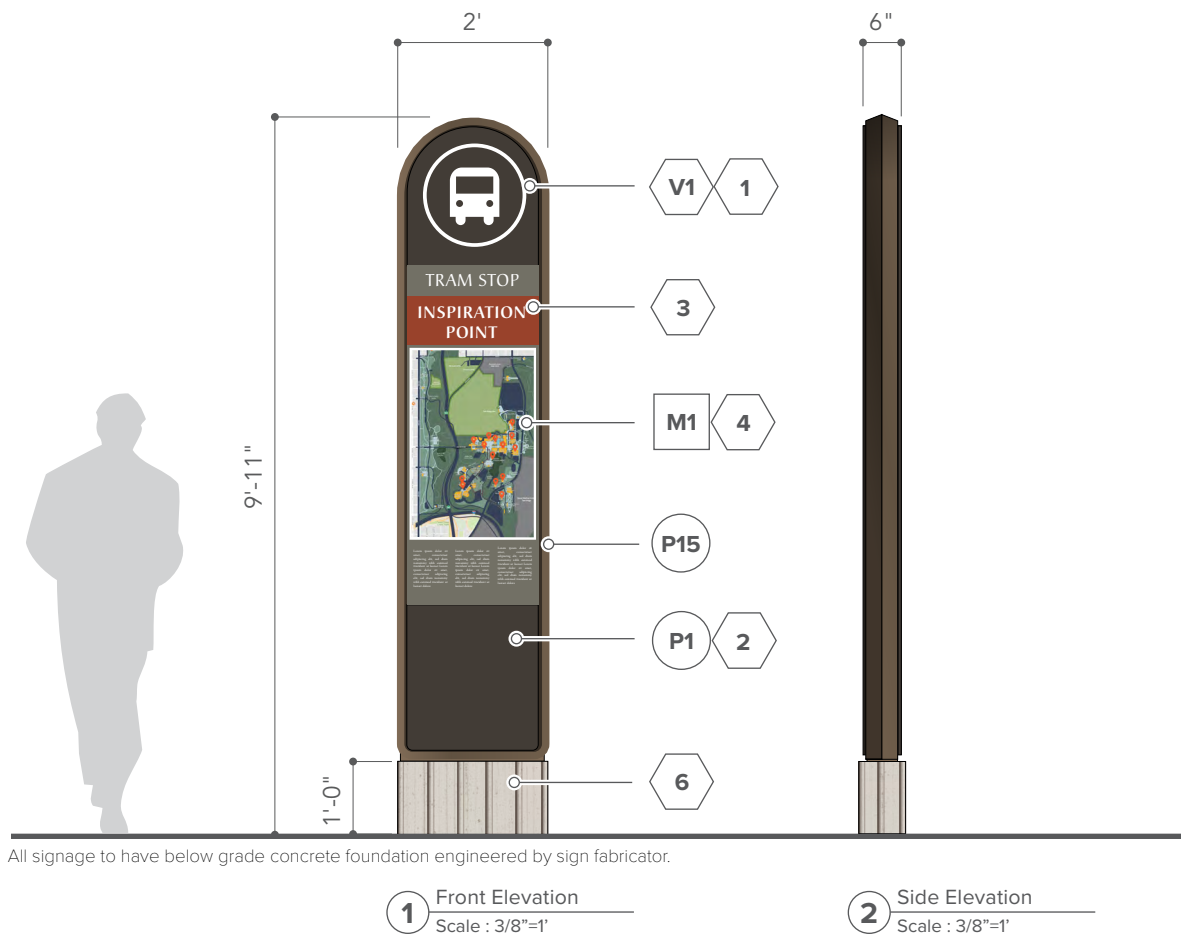
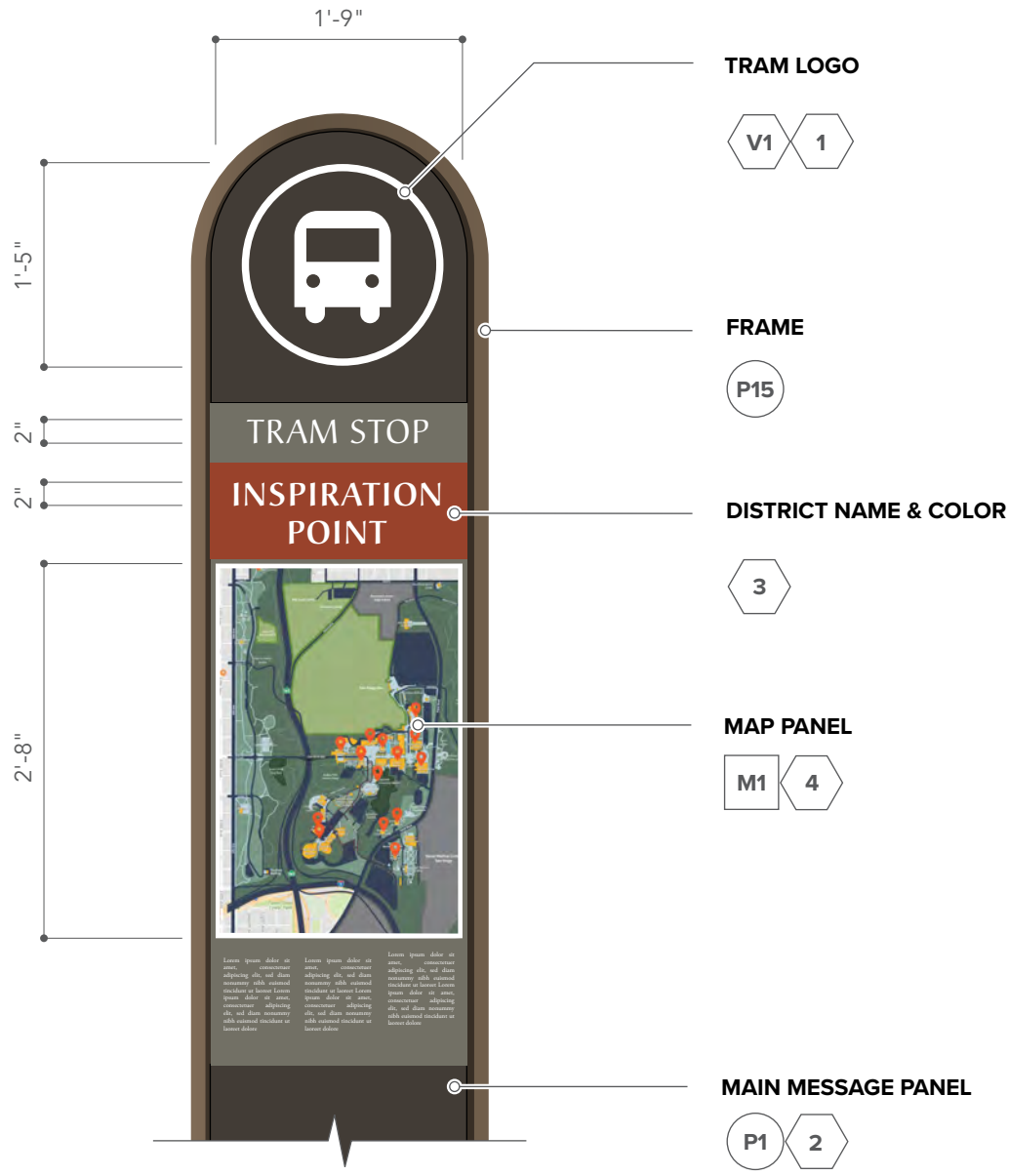

FIGURE 33A TRAM STOP (DETAILS)

The following illustrates the Tram Stop in detail, verifying materials used and measurements for the layout of the sign. The district color will change based on the district the sign is in.



1 Front Elevation
Scale : 3/4"=1'

FIGURE 34 PEDESTRIAN DIRECTIONAL/DIRECTORY

The following sign is to be used primary pedestrian zones / plazas throughout the Park to not only direct guests to the different destinations and amenities but also include a directory map that provides more information about the area in which they are located. The following design allows for a digital directory panel if appropriate within the park which the sign to be manufactured of painted aluminum, digitally printed izeone map, and precast base.

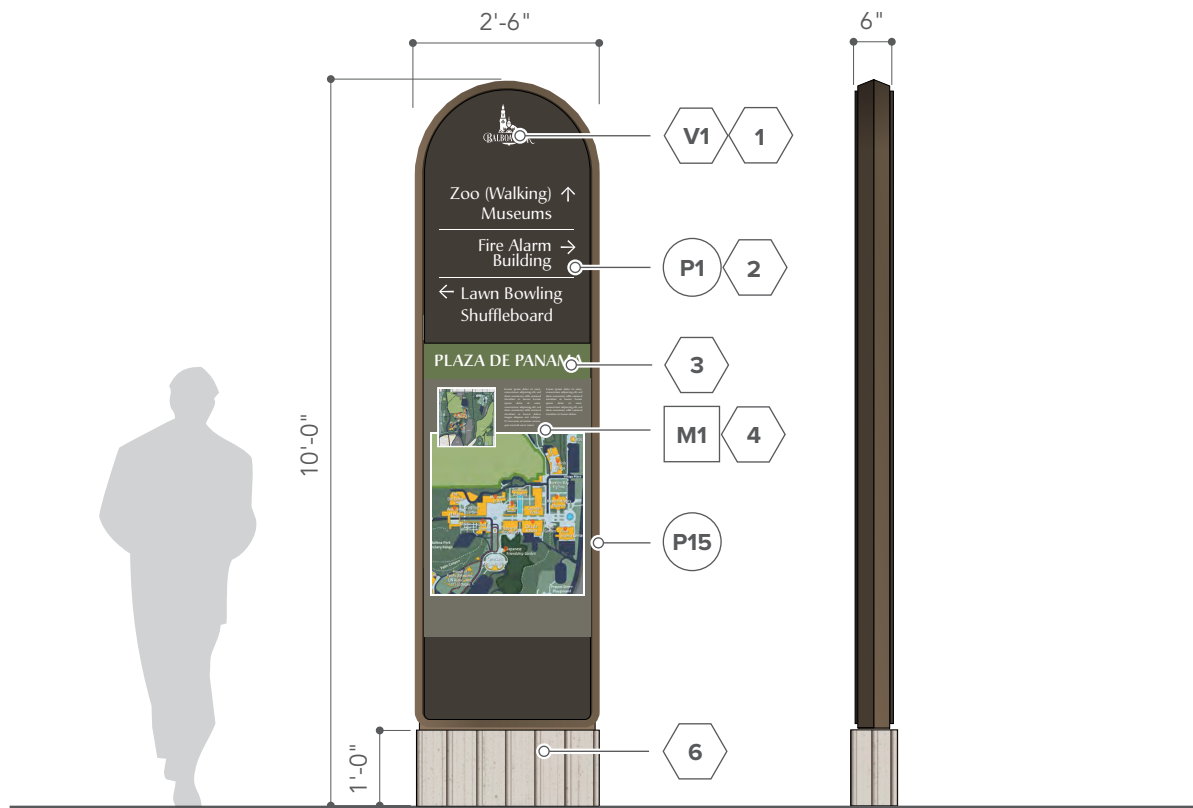

All signage to have below grade concrete foundation engineered by sign fabricator.

1 Front Elevation
Scale : 3/8"-1"

2 Side Elevation
Scale : 3/8"-1"

FIGURE 34A

PEDESTRIAN DIRECTIONAL/DIRECTORY (DETAILS)

The following illustrates the Pedestrian Directional/Directory in detail, verifying materials used and measurements for the layout of the sign. The district color will change based on the district the sign is in.



1 Front Elevation
Scale : 3/4"=1'

FIGURE 35

RULES AND REGULATIONS

The following freestanding sign is to be used provide guests with the rules and regulations / code of conduct of the Park. All messaging shown is placeholder only and is to be provided by the Parks Department.

NOTES

The following illustrates the 1-sided building and location signage used throughout the park. Sign to be 3" thick and manufactured of painted aluminum with a 60° arch top and 1-1/2" radius bottom corners.

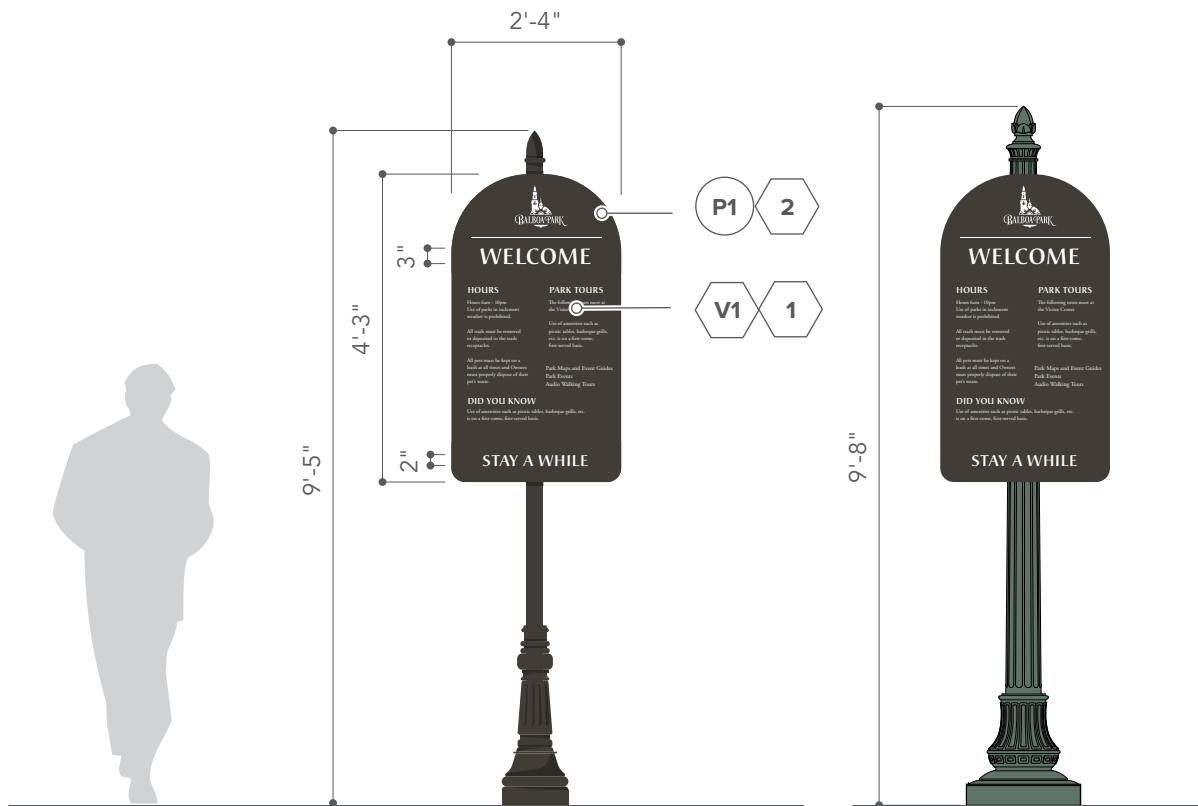

All signage to have below grade concrete foundation engineered by sign fabricator.

1 Front Elevation (Overall)
Scale : 3/8"=1'

3 Front Elevation (Prado)
Scale : 3/8"=1'

FIGURE 35A

RULES AND REGULATIONS (DETAILS)

The following illustrates the rules and regulations sign in detail, verifying materials used and measurements for the layout of the sign.

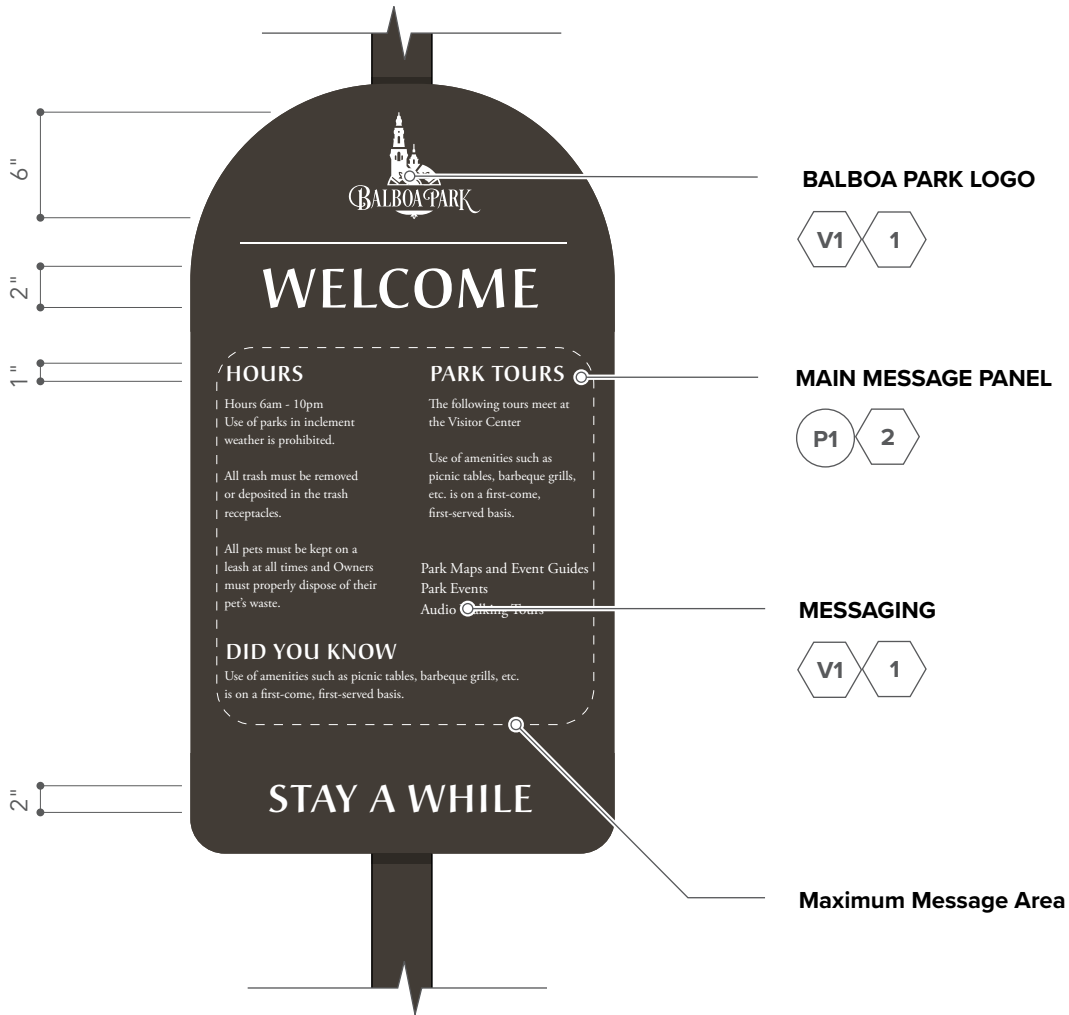

1 Front Elevation
Scale : 1"=1'

SECTION 5

POLE, BASE & MOUNTING SPECIFICATIONS

FIGURE 36 MARINER POLE & BASE

The following illustrates the Mariner Pole.

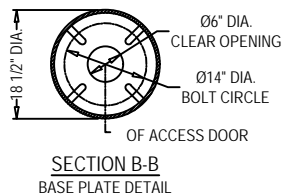
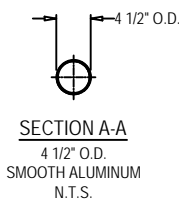
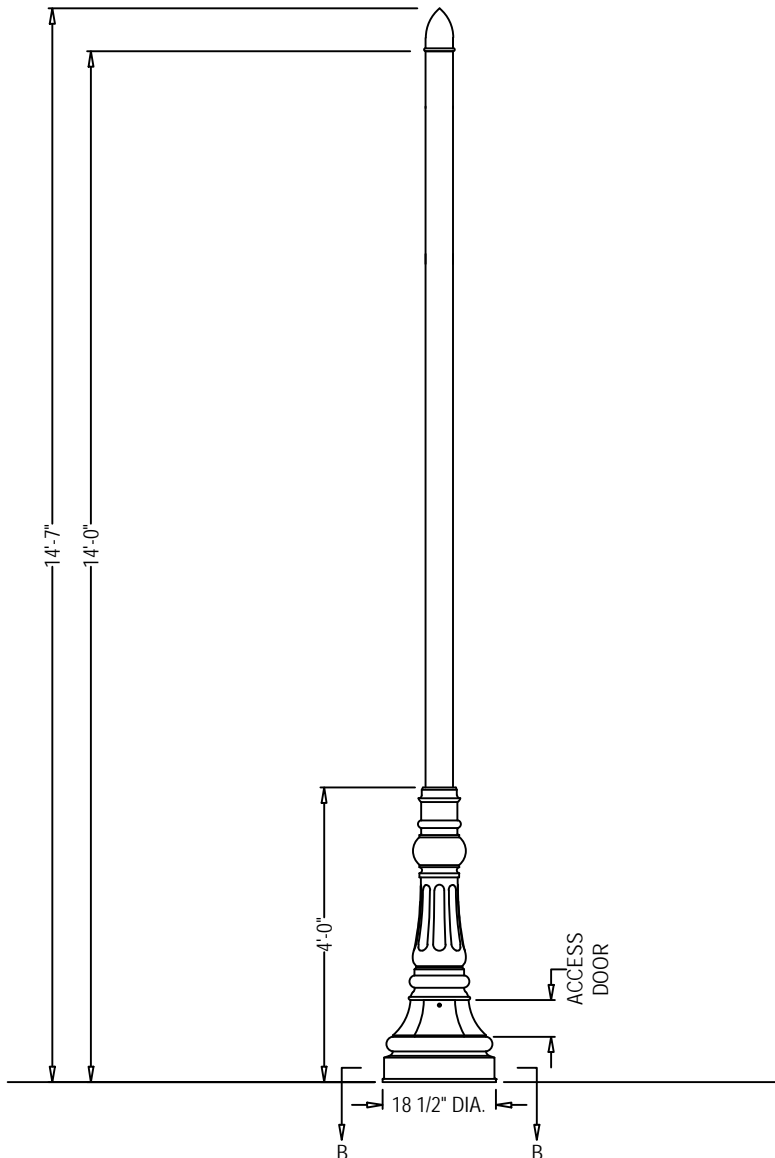

LAMP POST SPECIFICATIONS

STYLE: Mariner

HEIGHT: 14'-0"

MATERIAL: Shaft - 4" SCH-40 Aluminum Pipe (4 1/2" OD) 6061-T6
Base - 1 Piece, Heavy Wall Cast Aluminum Alloy A.N.S.I. 356, PER A.S.T.M. B26-95

FINISH: Powder Coat - To match Corinthian Bronze Metallic

ACCESS DOOR: Located in base secured with tamper proof hex socket security machine screws

GROUND STUD PROVISIONS: Drill and tap inside wall of base opposite access door to accommodate a 1/4"-20 ground stud (stud by others)

ANCHOR BOLTS: (4) 3/4" X 24" + 3" hook (fully galvanized with 1 galvanized nut and 1 galvanized washer per bolt)

BOLT PROJECTION: 3" required

CATALOG NUMBER:
Pole - APSMRN-18-14.00-S45-CU
Pole Finial-AFNBL-4.0-07.00-CU

SPRING CITY ELECTRICAL MFG. CO.
Hall and Main Streets - P.O. Box 19 -
Spring City, PA 19475
PHONE (610) 948-4000
FAX (610) 948-5577
www.springcity.com

DESCRIPTION:
The 14'0" Mariner with Auto Traffic Directional Signs

FIGURE 37 MARINER POLE CAP

The following illustrates the Mariner Pole Cap.

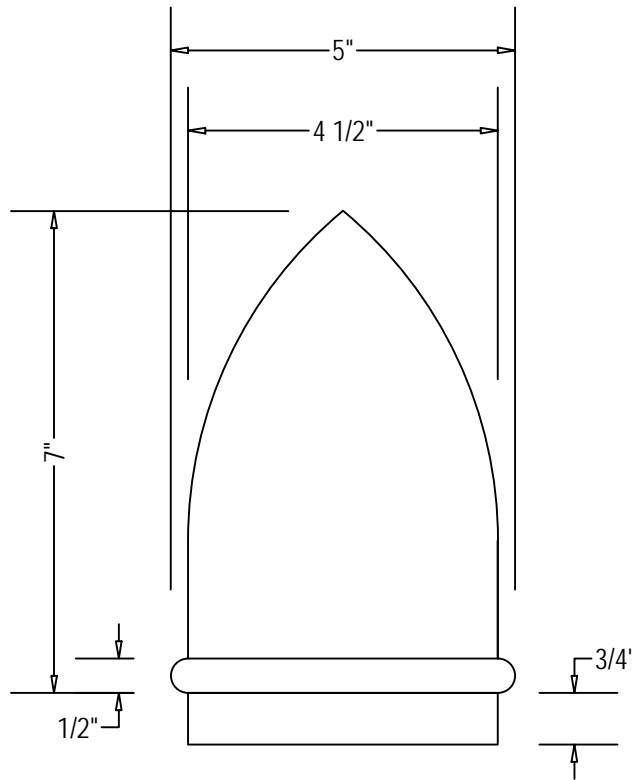

POLE CAP SPECIFICATIONS

STYLE: Mariner Pole Cap

HEIGHT: 7"

BASE: 5" Diameter

MATERIAL: Cast Aluminum Alloy A.N.S.I. 356 Per A.S.T.M. B26-95

FINISH: Powder Coat - To match Corinthian Bronze Metallic

CATALOG NUMBER: AFNBLB-4.5-07.00-CU

SPRING CITY ELECTRICAL MFG. CO.
 Hall and Main Streets - P.O. Box 19 -
 Spring City, PA 19475
 PHONE (610) 948-4000
 FAX (610) 948-5577
 www.springcity.com

DESCRIPTION:
 The Mariner Pole Cap

FIGURE 38 MINI-MARINER POLE & BASE

The following illustrates the Mini-Mariner Pole.

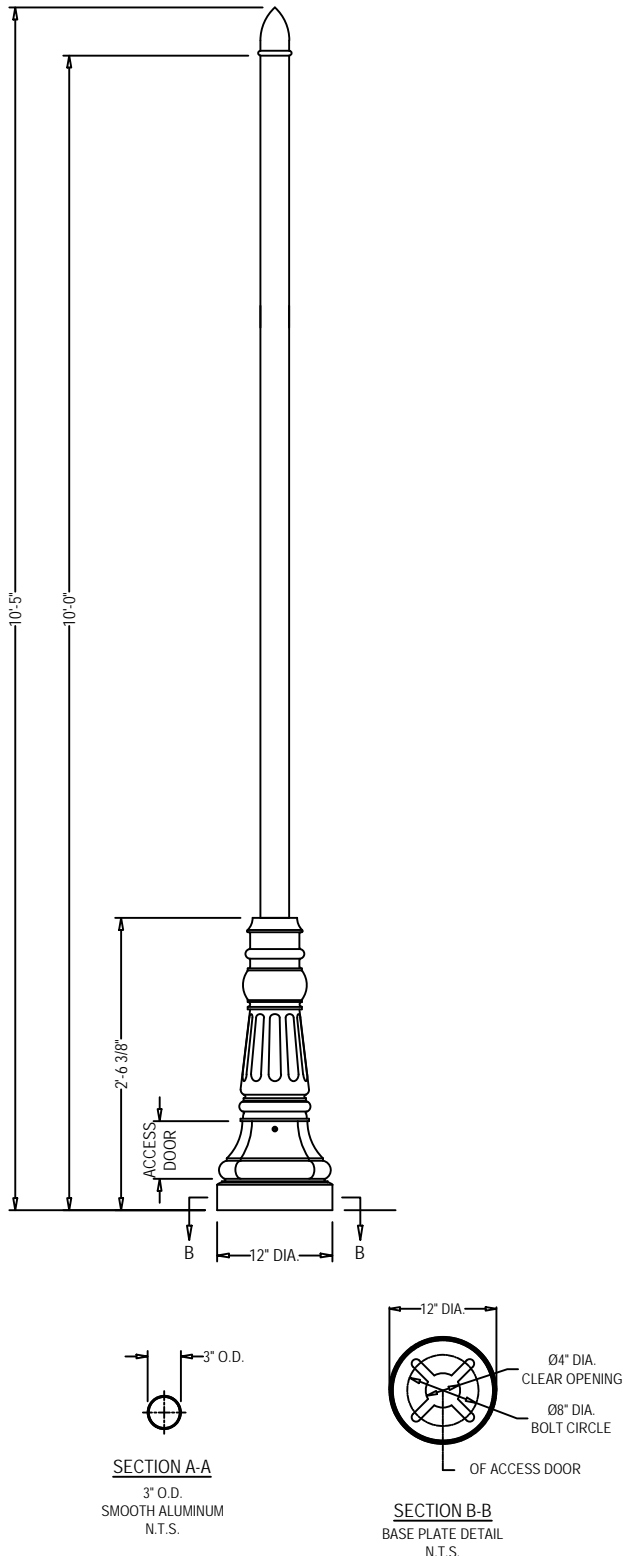

LAMP POST SPECIFICATIONS

STYLE: Mini-Mariner

HEIGHT: 10'-0"

BASE: 12" Diameter

MATERIAL: Shaft - 2 1/2" SCH-40 Aluminum Pipe (3" OD) 6061-T6
Base - Cast Aluminum Alloy A.N.S.I. 356, PER A.S.T.M. B26-95

FINISH: Powder Coat - To match Corinthian Bronze Metallic

ACCESS DOOR: Located in base secured with tamper proof hex socket security machine screws

GROUND PROVISIONS: Drill and tap inside base opposite access door to accommodate a 1/4"-20 ground stud (stud by others)

ANCHOR BOLTS: (4) 3/4" X 17" + 3" hook (fully galvanized with 1 galvanized nut and 1 galvanized washer per bolt)

BOLT PROJECTION: 3" required

CATALOG NUMBER:
Pole - APSMNM-12-10.00-S30-CU
Pole Finial-AFNBLB-3.0-05.00-CU

SPRING CITY ELECTRICAL MFG. CO.
Hall and Main Streets - P.O. Box 19 -
Spring City, PA 19475
PHONE (610) 948-4000
FAX (610) 948-5577
www.springcity.com

DESCRIPTION:
The 10'0" Mini-Mariner with Tram Stop Sign

FIGURE 39 MINI-MARINER POLE CAP

The following illustrates the Mini-Mariner Pole Cap.

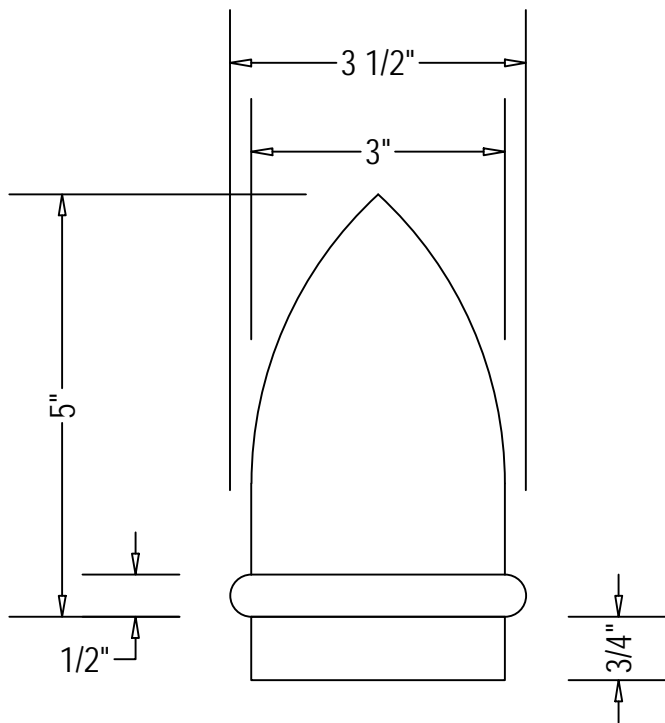

POLE CAP SPECIFICATIONS

STYLE: Mini-Mariner Pole Cap

HEIGHT: 5"

BASE: 3 1/2" Diameter

MATERIAL: Cast Aluminum Alloy A.N.S.I. 356 Per A.S.T.M. B26-95

FINISH: Powder Coat - To match Corinthian Bronze Metallic

CATALOG NUMBER: AFNBLB-3.0-05.00-CU

SPRING CITY ELECTRICAL MFG. CO.

Hall and Main Streets - P.O. Box 19 -
Spring City, PA 19475
PHONE (610) 948-4000
FAX (610) 948-5577
www.springcity.com

DESCRIPTION:

The Mini-Mariner Pole Cap

FIGURE 40 CAPISTRANO POLE & BASE

The following illustrates the Capistrano Pole which is to be used only within the Prado area of the park.



LAMP POST SPECIFICATIONS

STYLE: Capistrano

HEIGHT: 12'-6"

BASE: 19" Diameter

MATERIAL: Cast Aluminum Alloy ANSI 356 Per A.S.T.M. B26-95

FINISH: Powder Coat - To match Frazee Custom Color CZ-12-2935

ACCESS DOOR: Located in base secured with tamper proof hex socket security machine screws

GROUND STUD PROVISIONS: Drill and tap inside wall of base opposite access door to accommodate a 1/4"-20 ground stud (stud by others)

ANCHOR BOLTS: (4) 3/4" X 24" + 3" hook (fully galvanized with 1 galvanized nut and 1 galvanized washer per bolt)

BOLT PROJECTION: 3" required

TENON: 2 7/8" DIA. X 2" High (To Accept Finial)

CATALOG NUMBER:

Shaft -
APSCPS-19-12.50-2F-TN2.88/2.00-CU
Pole Finial - AFNWSO-04-08.75-CU

SPRING CITY ELECTRICAL MFG. CO.

Hall and Main Streets - P.O. Box 19 -
Spring City, PA 19475
PHONE (610) 948-4000
FAX (610) 948-5577
www.springcity.com

DESCRIPTION:

The 12'6" Capistrano Aluminum Post with Tram Stop Sign

FIGURE 41 CAPISTRANO POLE CAP

The following illustrates the Capistrano Pole Cap which is to be used only within the Prado area of the park.

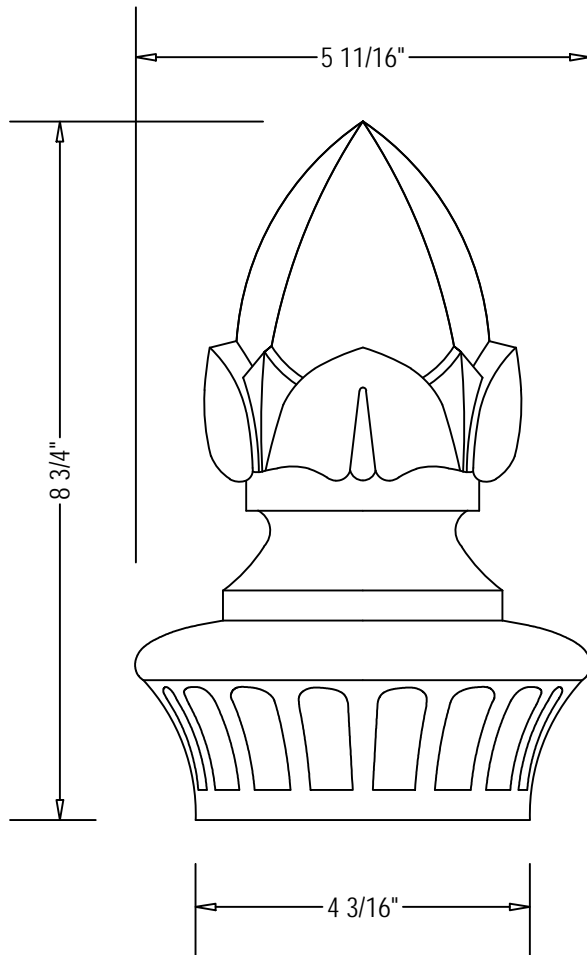

POLE CAP SPECIFICATIONS

STYLE: Capistrano Pole Cap

HEIGHT: 8 3/4"

BASE: 5 11/16" Diameter

MATERIAL: Cast Aluminum Alloy A.N.S.I. 356 Per A.S.T.M. B26-95

FINISH: Powder Coat - To match Frazee Cuton Color CZ-12-2935

CATALOG NUMBER: AFNWSO-04-08.75-CU

SPRING CITY ELECTRICAL MFG. CO.
Hall and Main Streets - P.O. Box 19 -
Spring City, PA 19475
PHONE (610) 948-4000
FAX (610) 948-5577
www.springcity.com

DESCRIPTION:
The Capistrano Pole Cap

FIGURE 42

TYPICAL BRACKET AND SIGN CONNECTION - POLE MOUNTED SIGN CONNECTIONS

The following illustrates the typical bracket and sign connection- pole mounted sign connections for the signage throughout the park. Casted brackets, sign pipes and connections must be engineered for shear stress and vertical weight prior to fabrication and installation.

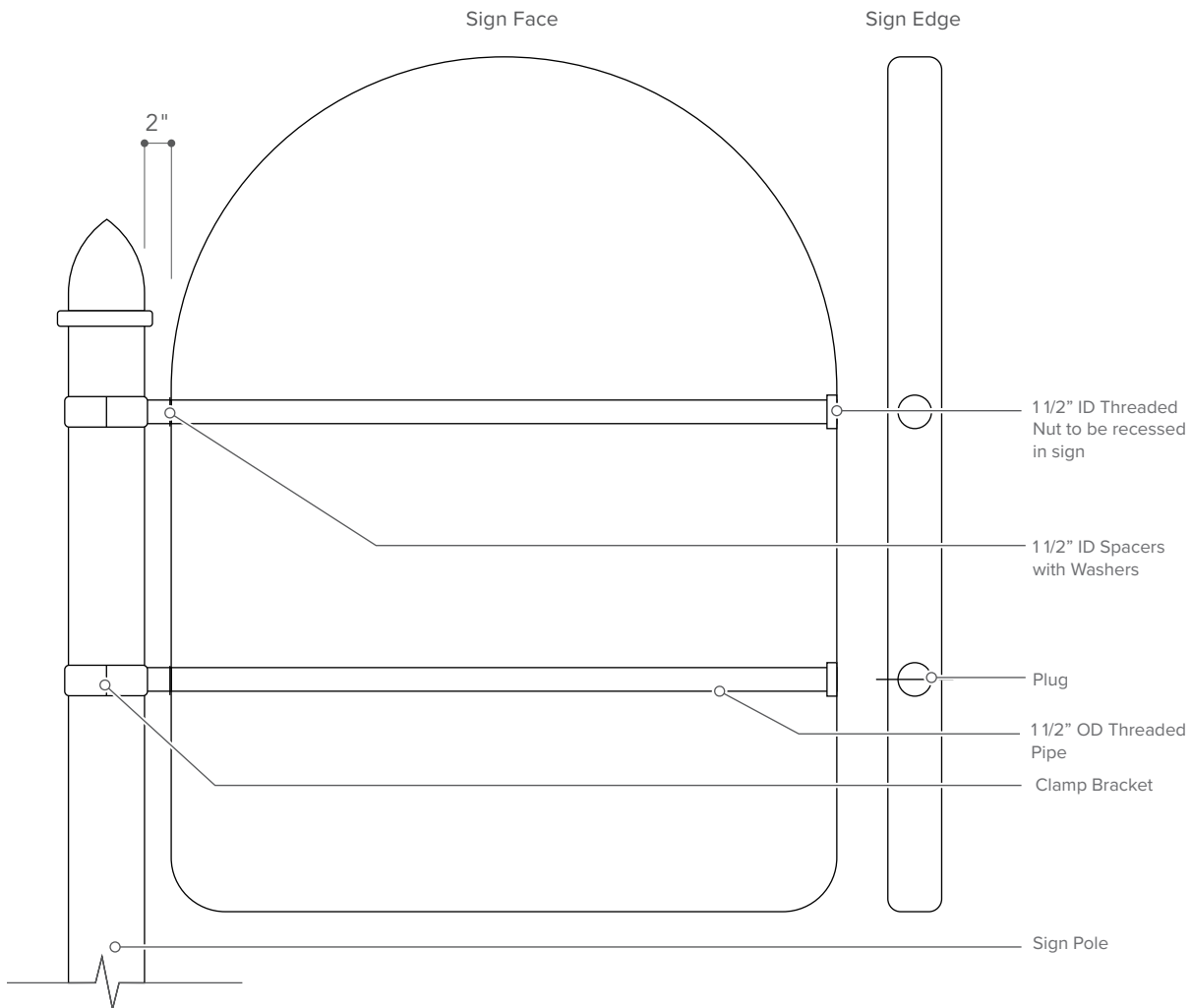

1 Front Elevation
Scale : 1"=1'

2 Side Elevation
Scale : 1"=1'

FIGURE 43 SIGN AND POLE DESIGN CONNECTION

The following illustrates the sign and pole design connection for the signage throughout the park.

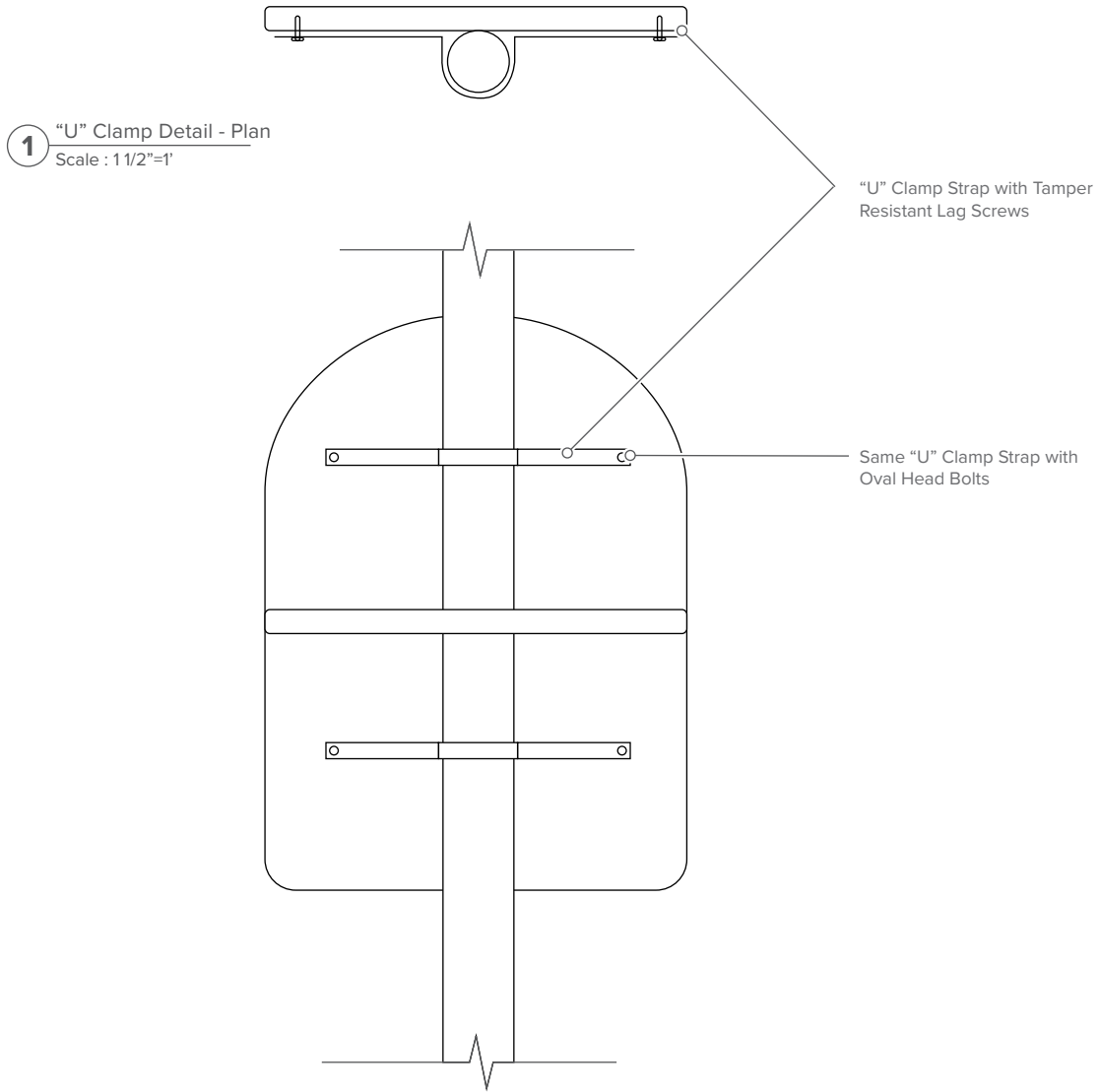

2 "U" Clamp Detail
Scale : 1 1/2"=1'

FIGURE 44

WALL MOUNT SIGN CONNECTION

The following illustrates the wall mount sign connection for the signage throughout the park. Where wall surface is smooth, use of epoxy glue to directly mount sign to wall signage is acceptable.

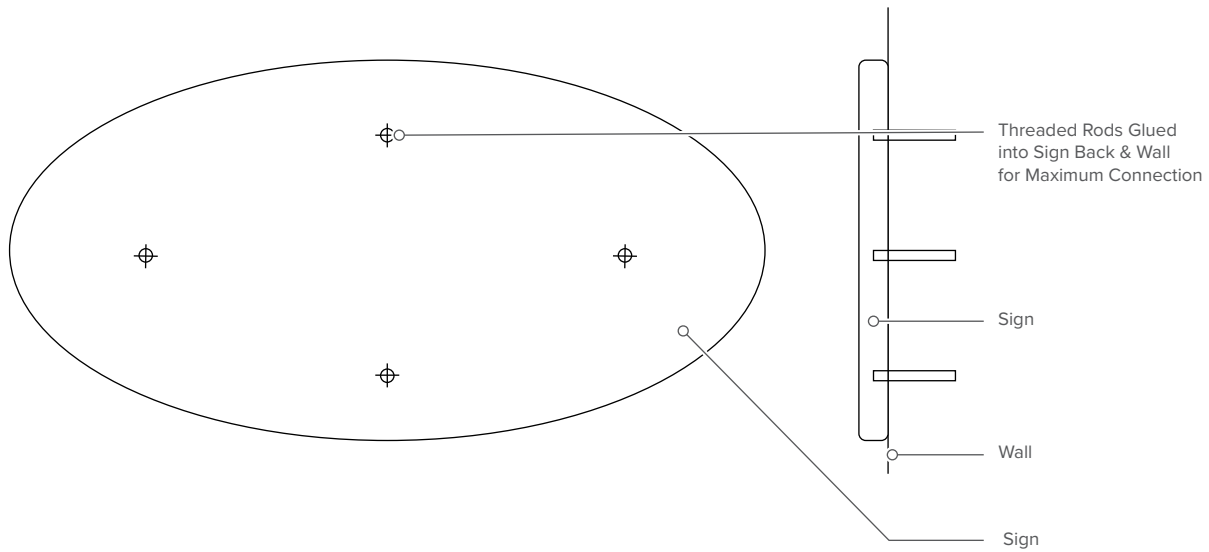

1 Front Elevation
Scale : 1"=1'

2 Side Elevation
Scale : 1"=1'

FIGURE 45 HANGING SIGN CONNECTION

The following illustrates the hanging sign connections for the signage throughout the park. Sign to be 2 sided hanging with eye bolts from opening soffit and top of sign with glue. Chain may be added for length.

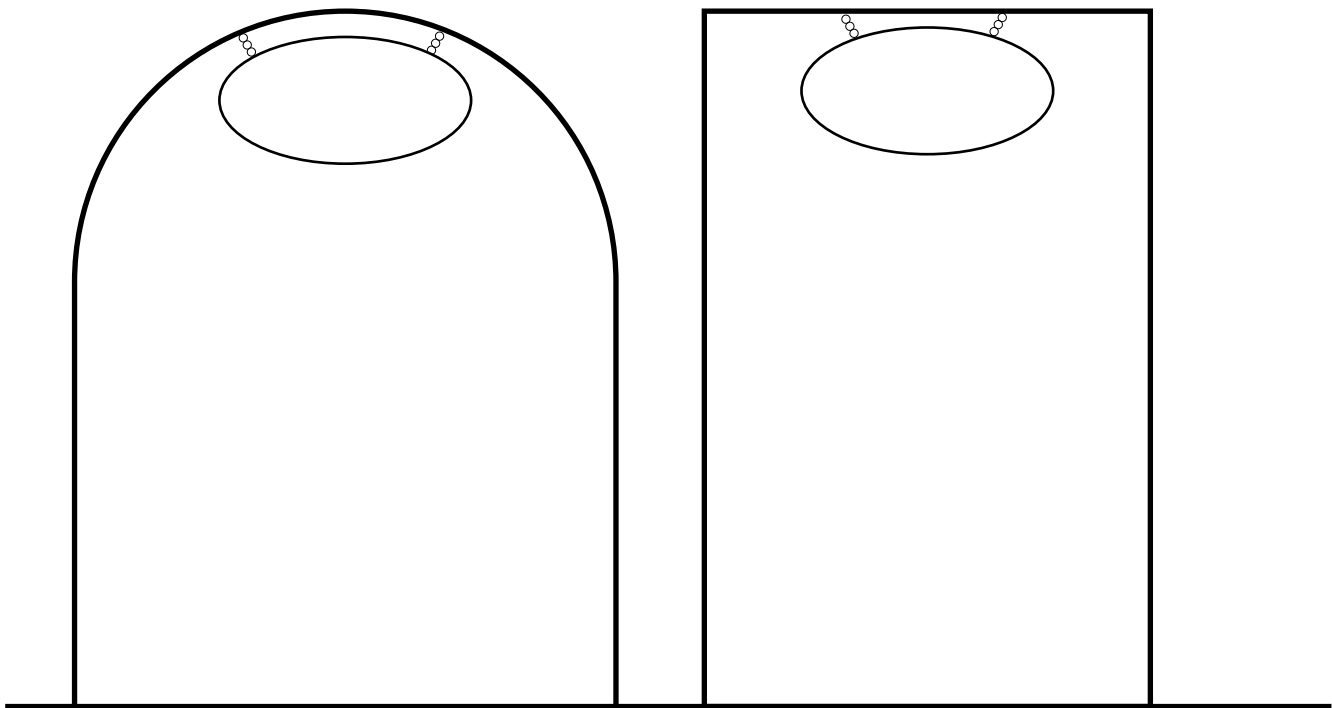

Arch Opening

Rectangular Opening

SECTION 6

PROGRAMMING

FIGURE 46 PROGRAMMING



RECOMMENDED LOCATIONS WILL BE PROVIDED AT LATER DATE.

FIGURE 47 SIGN LOCATION PLAN

RECOMMENDED LOCATIONS WILL BE PROVIDED AT LATER DATE.

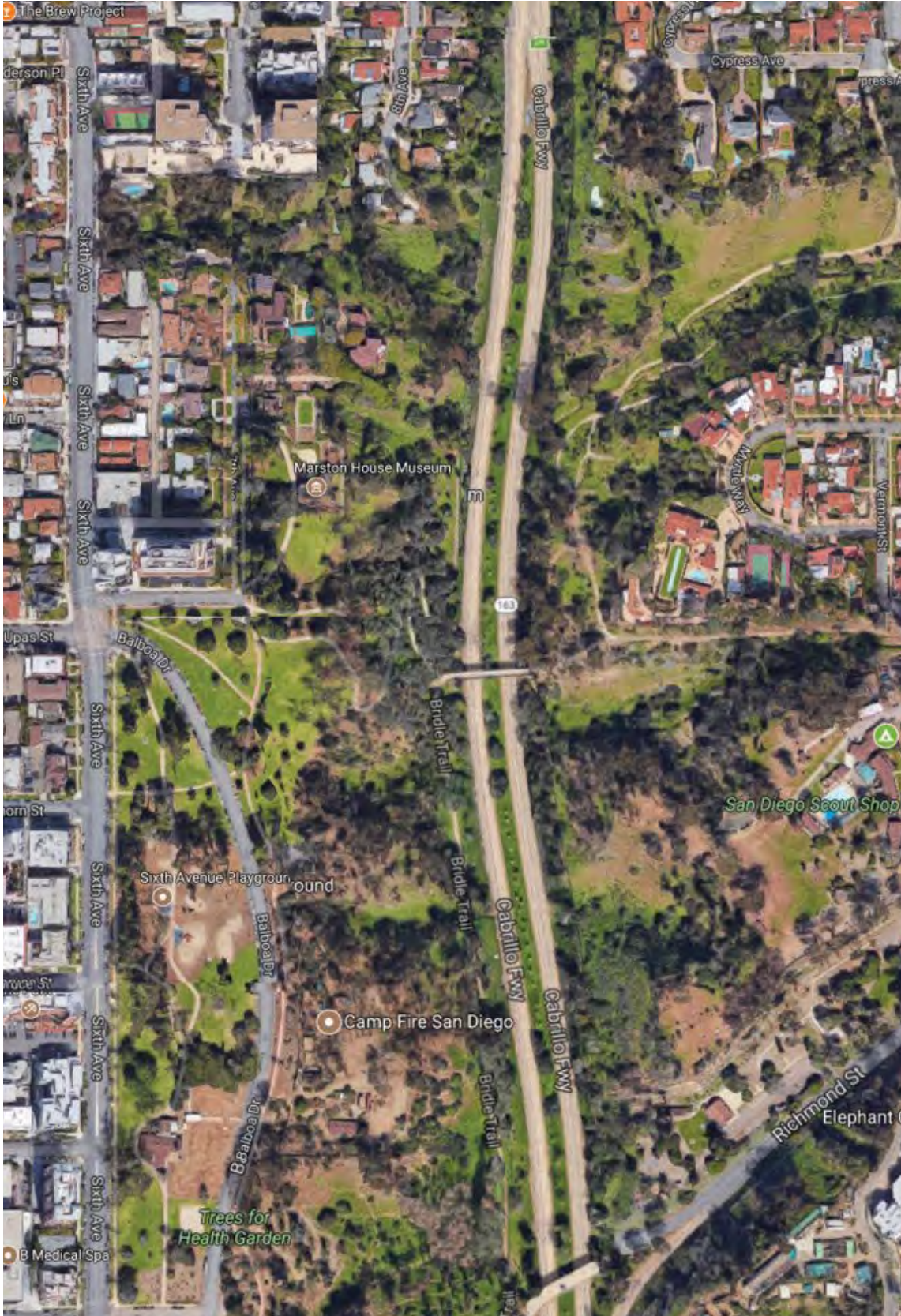

FIGURE 48 SIGN LOCATION PLAN

RECOMMENDED LOCATIONS WILL BE PROVIDED AT LATER DATE.



FIGURE 49 SIGN LOCATION PLAN

RECOMMENDED LOCATIONS WILL BE PROVIDED AT LATER DATE.

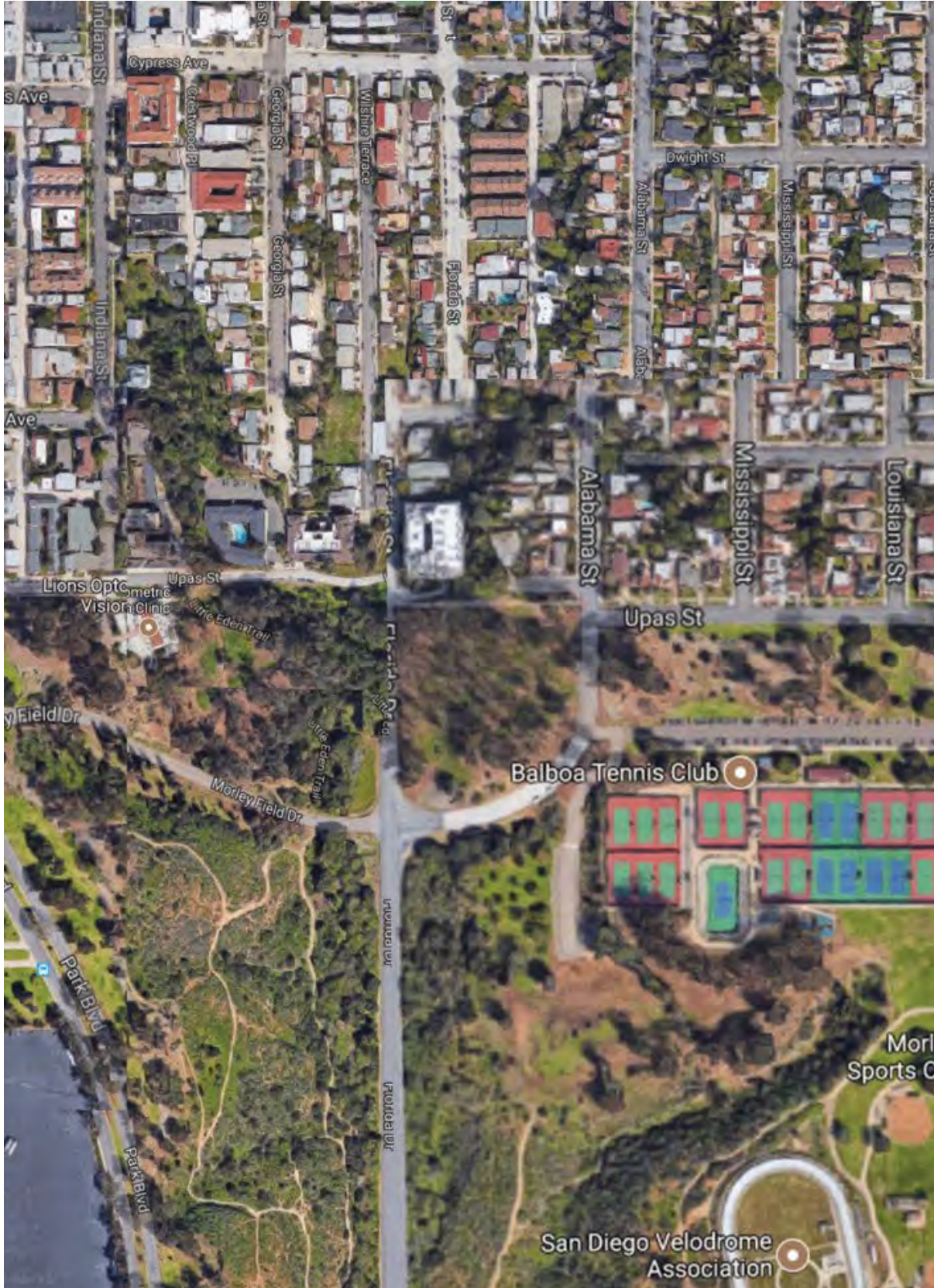

FIGURE 50 SIGN LOCATION PLAN

RECOMMENDED LOCATIONS WILL BE PROVIDED AT LATER DATE.

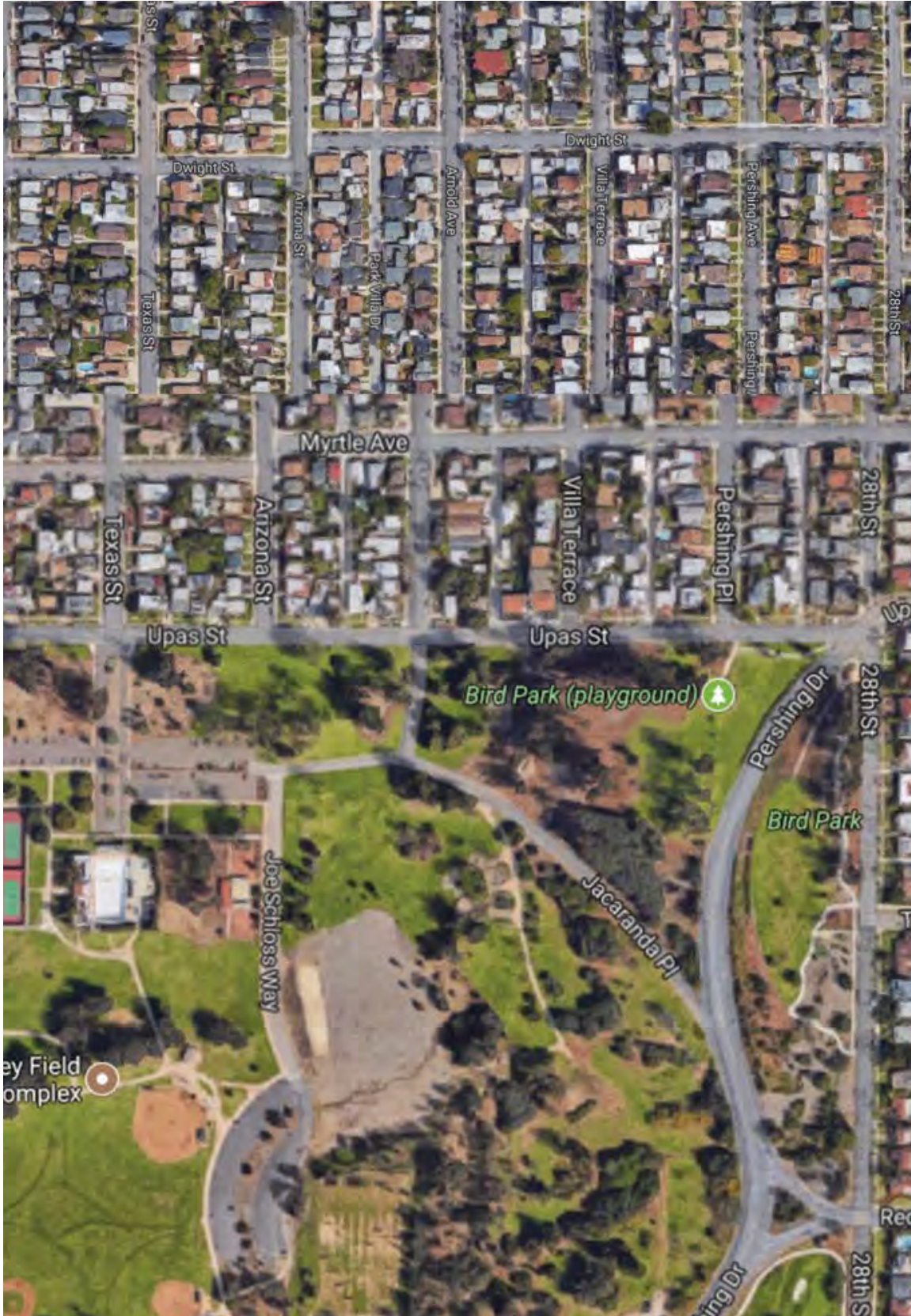

FIGURE 51 SIGN LOCATION PLAN

RECOMMENDED LOCATIONS WILL BE PROVIDED AT LATER DATE.

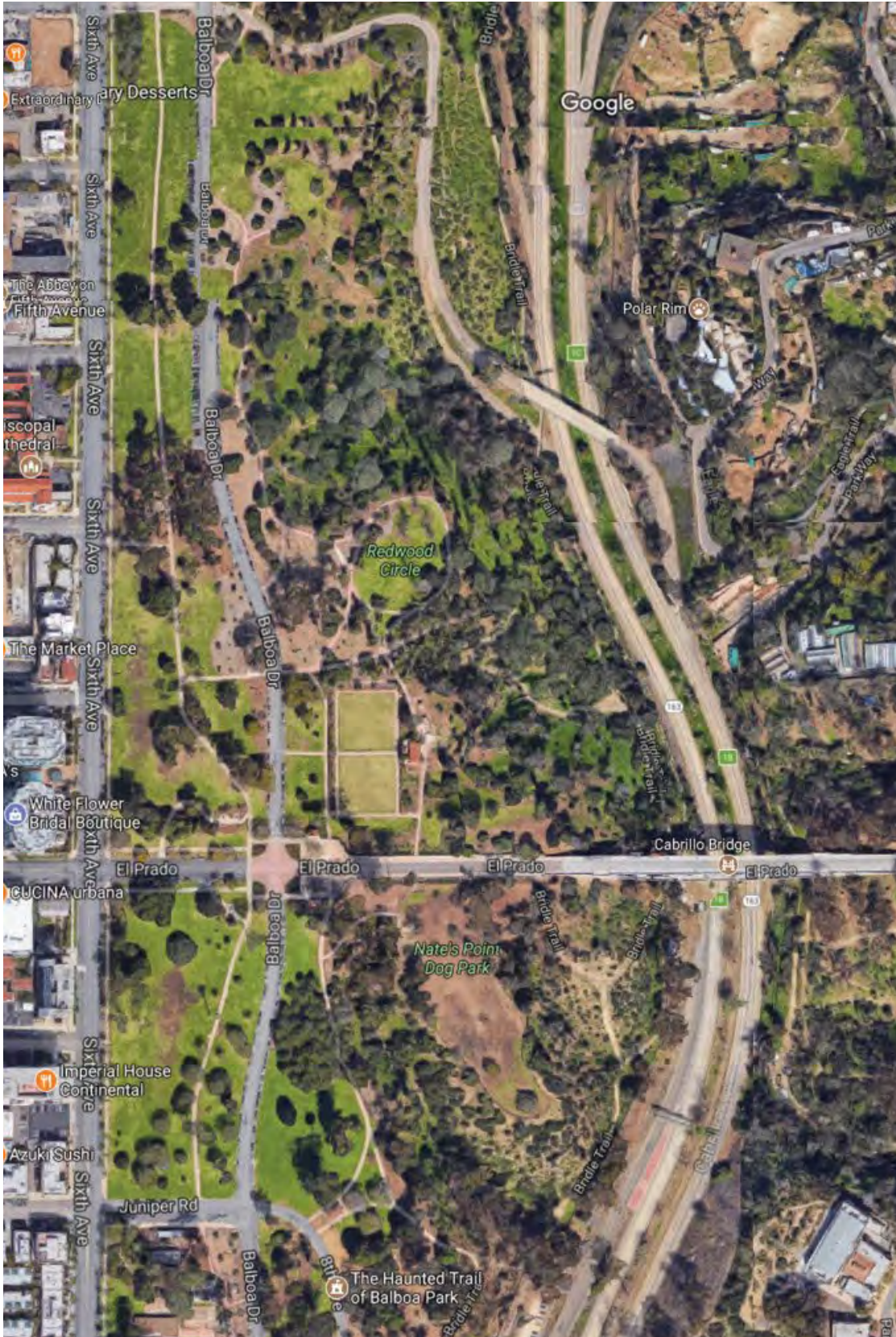

FIGURE 52 SIGN LOCATION PLAN

RECOMMENDED LOCATIONS WILL BE PROVIDED AT LATER DATE.

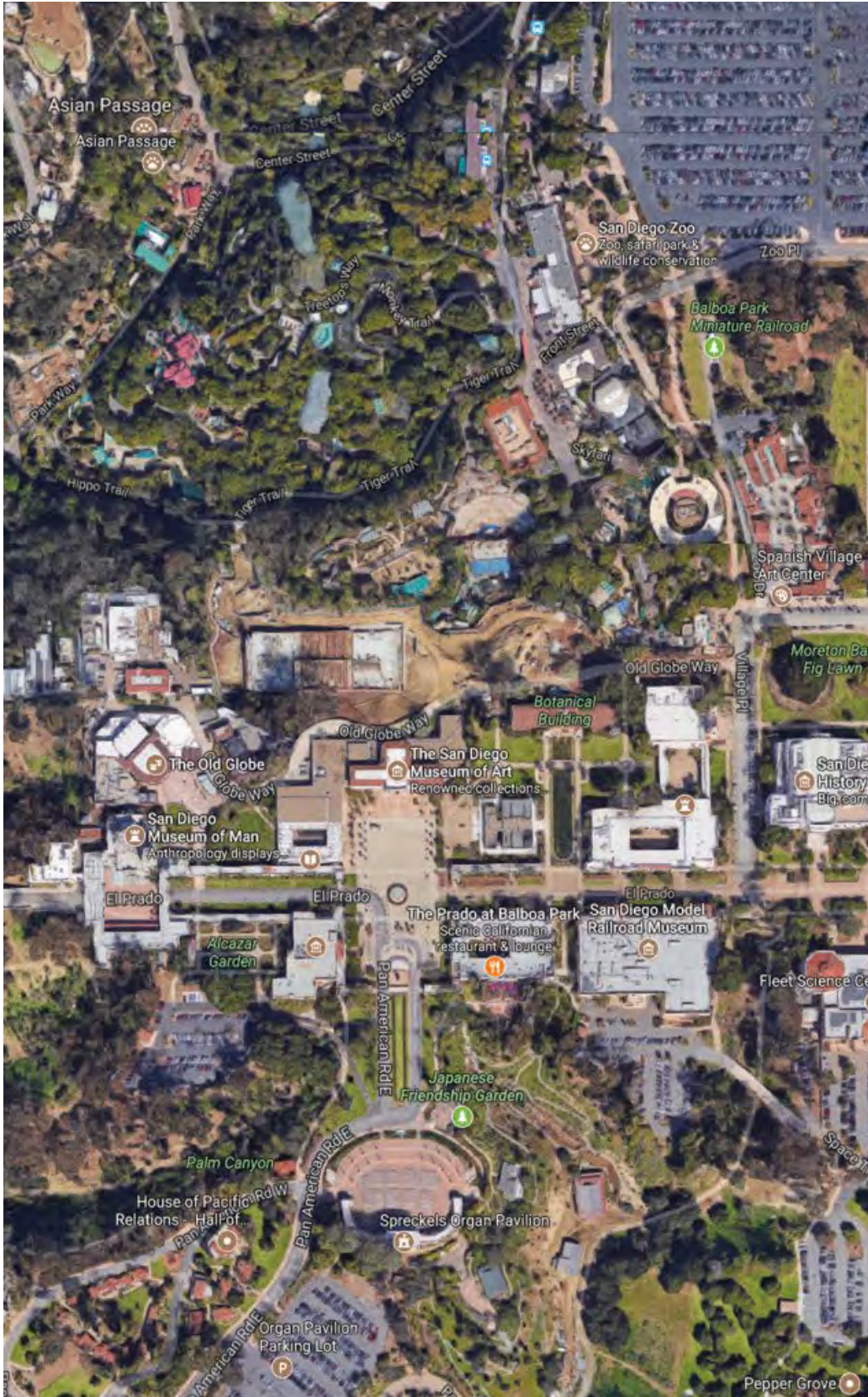

FIGURE 53 SIGN LOCATION PLAN

RECOMMENDED LOCATIONS WILL BE PROVIDED AT LATER DATE.



FIGURE 54 SIGN LOCATION PLAN

RECOMMENDED LOCATIONS WILL BE PROVIDED AT LATER DATE.



FIGURE 55 SIGN LOCATION PLAN

RECOMMENDED LOCATIONS WILL BE PROVIDED AT LATER DATE.



FIGURE 56 SIGN LOCATION PLAN

RECOMMENDED LOCATIONS WILL BE PROVIDED AT LATER DATE.



FIGURE 57 SIGN LOCATION PLAN

RECOMMENDED LOCATIONS WILL BE PROVIDED AT LATER DATE.

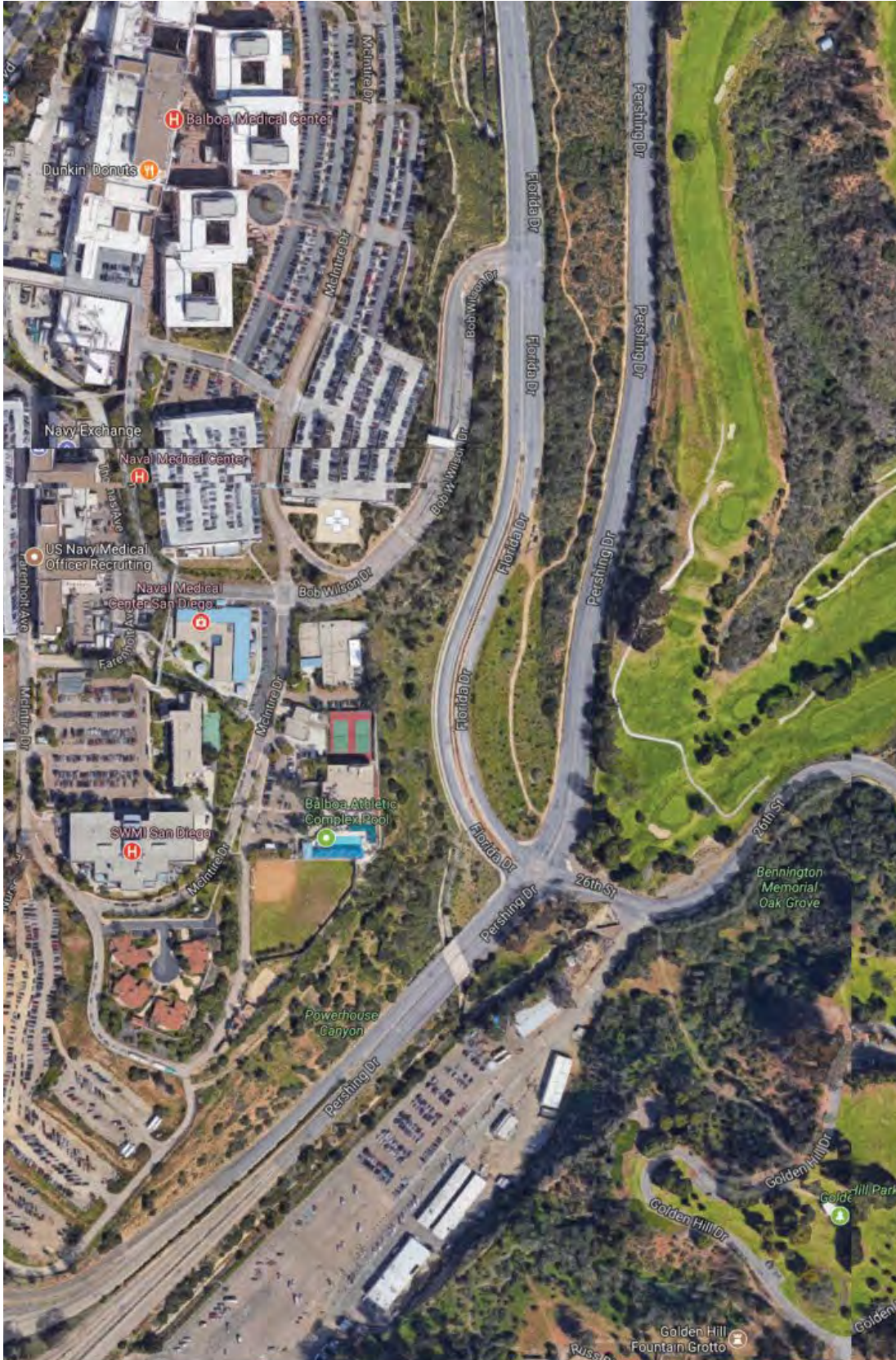

FIGURE 58 SIGN LOCATION PLAN

RECOMMENDED LOCATIONS WILL BE PROVIDED AT LATER DATE.

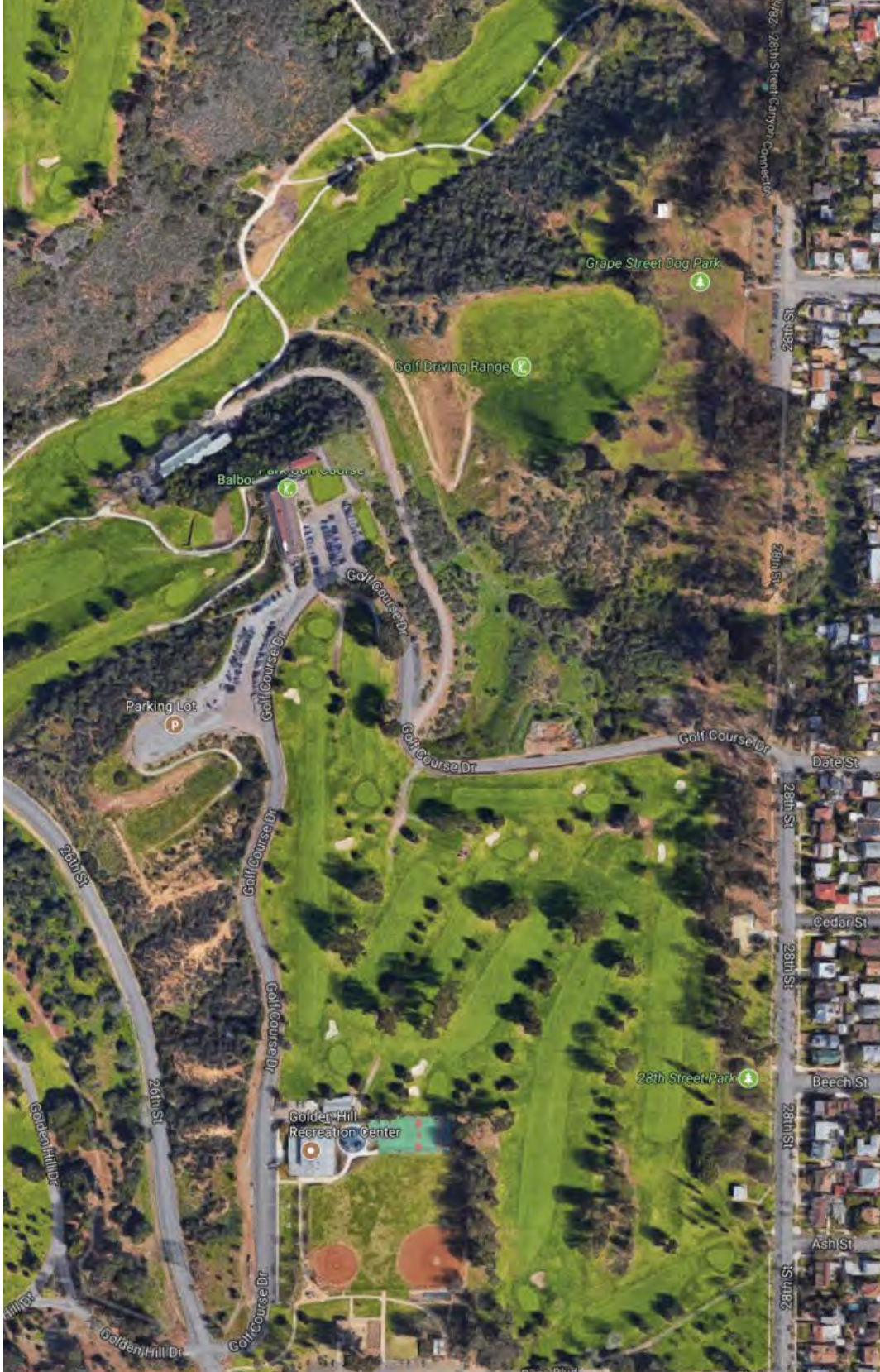

FIGURE 59 SIGN TYPE IMPLEMENTATION PRIORITIES

| SIGN TYPE | 1 | 2 | 3 | 4 | 5 | 6 |
|--------------------------------------|---|---|---|---|---|---|
| Off-Site Directional | | | | | X | |
| Tram Stop | X | | | | | |
| Auto Traffic Directional | X | | | | | |
| Auto Traffic Signs | | | | X | | |
| Pedestrian Orientation | X | | | | | |
| Pedestrian Directional | X | | | | | |
| Oval Hanging Sign | | | | | X | |
| 1-Sided Building & Location | | | | X | | |
| 2-Sided Building & Location | | | | X | | |
| Banner | | | | | | X |
| 1-Sided Historical Landmark | | | X | | | |
| Historical Landmark/Education Plaque | | | X | | | |
| High Speed Vehicular Directional | X | | | | | |
| Secondary Entry Monument | | | | X | | |
| Amenity Identity Monument | | | | X | | |
| Balboa Park Identity | | | | | X | |
| Parking Lot Identity | | X | | | | |
| Parking Lot Digital | | | X | | | |
| Parking Identity | X | | | | | |
| Tram Stop | X | | | | | |
| Pedestrian Directional/Directory | X | | | | | |
| Pedestrian Flag Directional | X | | | | | |
| Rules & Regulations | | | X | | | |
| Freestanding Street Identity | | | | | X | |
| Overhead Street Identity | | | | | | X |

Parking & Vehicular Signage

The ultimate goal should be to efficiently and effectively guides guests to the various parking lots and get them out of their cars so that they can walk, explore, and experience the park from a pedestrian orientation. Therefore it is essential to ensure the vehicular directionals clearly direct users to the parking lots and the different destinations as well as having parking signs that help guests orient themselves and remember where they parked.

Tram and Trolley Signage

The current issue with the tram and trolley signage is visibility, awareness and comfort. Therefore the signage will need to grow in scale and become more prominent while being located in comfortable / safe areas that guest frequent and don't mind waiting. This is a major amenity for the park, but if people cannot find the stops then it is not being utilized like it should be.

FIGURE 60

SIGN TYPE IMPLEMENTATION PRIORITIES

| AREA | 1 | 2 | 3 | 4 | 5 | 6 |
|-----------------------------|---|---|---|---|---|---|
| Northwest | | | | | | X |
| Sixth Avenue | X | | | | | |
| San Diego Zoo | | | | X | | |
| North Central | | | X | | | |
| Florida Canyon | X | | | | | |
| Morley Field | | | X | | | |
| Municipal Golf Courses | | | X | | | |
| Golden Hill Recreation Area | | | | X | | |
| Grape Street Area | | | | X | | |
| Inspiration Point | X | | | | | |
| The Prado | X | | | | | |
| The Palisades | X | | | | | |
| Pepper Grove Area | | X | | | | |
| Off-site Directionals | | | | | | X |
| Caltrans | | | | | X | |

Clearly Identify Park Entrances

Adding and updating park identity signage at prominent park entrances not only to help define the Park’s edges but also provide certainty to users that they have arrived.

Update signage at Critical Intersections

While Balboa Park is very large, there are only a few critical nodes or intersections that play a part in the wayfinding throughout the park. Therefore it is important to update and enhance these critical decision making points with clear signage to guide guests to the different areas of the park.

Update all the Signage on the West Mesa

The West Mesa would be a great opportunity to test out and begin phasing the signage refurbishing overhaul. It is somewhat isolated from the rest of the park but has a variety of amenities and destinations that would be great to test out the new signage masterplan guidelines.

Roll out of Signage Guidelines on any new signs developed in all areas of the park.

Any new signs that are to be installed within the park should follow the new guidelines, even though they may be in areas that still have the older style and colors. It will be several years until the new signage guidelines is fully implemented so there will be a period of juxtaposition during the transition and that is okay. The goal is to help improve the wayfinding through out the park and while it may not feel cohesive the variation in style will still work towards the desired result.

FIGURE 61

SIGN SYSTEM BUDGETARY ESTIMATES

The final budgetary estimates will be updated upon approval of the signage at a later date upon review and coordination with a local fabricator.

These budgetary estimates are intended to provide price range information for budget allotment, and are accurate to within 20% of actual fabrication costs, in 2019 dollars.

Variables which will affect the actual pricing structures include:

Graphics

- We assume camera ready art will be provided to the fabricator, in size sufficient to successfully render all logos and maps.
- All vinyl copy prices are based on copy as indicated on drawings. Changes in the quantity of characters required on each sign will change the price.

Installation

Excavation, footing and installation of sign poles included. Pricing assumes installation of all signs on level ground. Installation on sloped terrain will significantly increase installation prices.

- Concrete cutting, if required, will be additional (\$30.00 to \$50.00 per location, in quantity).
- Installation pricing assumes access to job site during normal working hours (8am-5pm, M-F) and unobstructed access to all sign locations. Pricing assumes normal billing rates, not prevailing wage rates.
- Removal of existing signage not included.

Banners

- Assumes the banner background color is a standard, available color in a high quality awning fabric, such as Unitex or Sunbrella.

General

- Quantity discounts noted assumes at least the indicated quantity would be ordered concurrently.
- City of San Diego sign permits and permit processing fees not included. Sign poles and bases are as provided by the manufacturer, including finish quality and color matching.

The following is recommended to maximize cost savings:

- Provide a sign storage area for the installation process.
- Screen print maps directly on sign panel. Provide long term storage area for future stock of sign parts.
- Purchase all foundry cast and fabricated brackets and caps at the onset of the first phase to realize quantity discounts.

FIGURE 62

SIGN SYSTEM BUDGETARY ESTIMATES

The final budgetary estimates will be updated upon approval of the signage at a later date upon review and coordination with a local fabricator.

| SIGN TYPE | UNIT PRICE |
|--------------------------------------|------------|
| Off-Site Directional | \$1,650 |
| Tram Stop | \$1,650 |
| Auto Traffic Directional | \$2,000 |
| Auto Traffic Signs | \$1,650 |
| Pedestrian Orientation | \$2,500 |
| Pedestrian Directional | \$2,000 |
| Oval Hanging Sign | \$700 |
| 1-Sided Building & Location | \$1,650 |
| 2-Sided Building & Location | \$1,650 |
| Banner | - |
| 1-Sided Historical Landmark | \$1,650 |
| Historical Landmark/Education Plaque | \$1,650 |
| High Speed Vehicular Directional | \$2,500 |
| Secondary Entry Monument | \$10,00 |
| Amenity Identity Monument | \$5,000 |
| Balboa Park Identity | \$2,500 |
| Parking Lot Identity | \$7,000 |
| Parking Lot Digital | \$9,000 |
| Parking Identity | \$1,000 |
| Tram Stop | \$11,000 |
| Pedestrian Directional/Directory | \$14,000 |
| Pedestrian Flag Directional | \$9,000 |
| Rules & Regulations | \$4,500 |
| Freestanding Street Identity | \$3,000 |
| Overhead Street Identity | \$2,500 |